

Official Monographs

Acebutolol Hydrochloride

アセブトロール塩酸塩

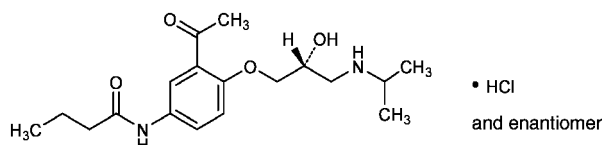

$C_{18}H_{28}N_2O_4 \cdot HCl$: 372.89
N-[3-Acetyl-4-[(2*RS*)-2-hydroxy-3-(1-methylethyl)aminopropoxy]phenyl]butanamide monohydrochloride
[34381-68-5]

Acebutolol Hydrochloride, when dried, contains not less than 98.0% and not more than 102.0% of acebutolol hydrochloride ($C_{18}H_{28}N_2O_4 \cdot HCl$).

Description Acebutolol Hydrochloride occurs as white to pale yellow-white, crystals or crystalline powder.

It is freely soluble in water, in methanol, in ethanol (95) and in acetic acid (100), and practically insoluble in diethyl ether.

A solution of Acebutolol Hydrochloride (1 in 20) shows no optical rotation.

Identification (1) Determine the absorption spectrum of a solution of Acebutolol Hydrochloride in 0.01 mol/L hydrochloric acid TS (1 in 100,000) as directed under Ultraviolet-visible Spectrophotometry <2.24>, and compare the spectrum with the Reference Spectrum: both spectra exhibit similar intensities of absorption at the same wavelengths.

(2) Determine the infrared absorption spectrum of Acebutolol Hydrochloride, previously dried, as directed in the potassium bromide disk method under Infrared Spectrophotometry <2.25>, and compare the spectrum with the Reference Spectrum: both spectra exhibit similar intensities of absorption at the same wave numbers.

(3) A solution of Acebutolol Hydrochloride (1 in 100) responds to Qualitative Tests <1.09> for chloride.

Melting point <2.60> 141 – 145°C

Purity (1) Heavy metals <1.07>—Proceed with 1.0 g of Acebutolol Hydrochloride according to Method 2, and perform the test. Prepare the control solution with 1.0 mL of Standard Lead Solution (not more than 10 ppm).

(2) Arsenic <1.11>—Prepare the test solution with 1.0 g of Acebutolol Hydrochloride according to Method 3, and perform the test (not more than 2 ppm).

(3) Related substances—Dissolve 40 mg of Acebutolol Hydrochloride in 2 mL of methanol, and use this solution as the sample solution. Pipet 1 mL of the sample solution, add methanol to make exactly 25 mL, and pipet 1 mL of this solution, add methanol to make exactly 20 mL, and use this solution as the standard solution. Perform the test with these solutions as directed under Thin-layer Chromatography <2.03>. Spot 5 μ L each of the sample solution and standard solution on a plate of silica gel for thin-layer chromatography. Develop the plate with the upper layer of a mixture of

water, 1-butanol and acetic acid (100) (5:4:1) to a distance of about 10 cm, and air-dry the plate. Examine under ultraviolet light (main wavelength: 365 nm): the spots other than the principal spot obtained from the sample solution are not more intense than the spot from the standard solution.

Loss on drying <2.41> Not more than 1.0% (0.5 g, 105°C, 3 hours).

Residue on ignition <2.44> Not more than 0.2% (1 g).

Assay Weigh accurately about 0.25 g of Acebutolol Hydrochloride, previously dried, dissolve in 20 mL of acetic acid (100), add 80 mL of acetic anhydride, and titrate <2.50> with 0.1 mol/L perchloric acid VS (potentiometric titration). Perform a blank determination in the same manner, and make any necessary correction.

Each mL of 0.1 mol/L perchloric acid VS
= 37.29 mg of $C_{18}H_{28}N_2O_4 \cdot HCl$

Containers and storage Containers—Well-closed containers.

Acemetacin

アセメタシン

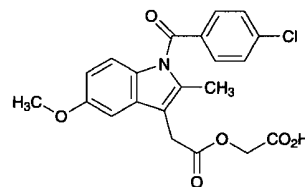

$C_{21}H_{18}ClNO_6$: 415.82
2-[2-[1-(4-Chlorobenzoyl)-5-methoxy-2-methyl-1*H*-indol-3-yl]acetyloxy]acetic acid
[53164-05-9]

Acemetacin, when dried, contains not less than 99.0% and not more than 101.0% of acemetacin ($C_{21}H_{18}ClNO_6$).

Description Acemetacin occurs as a light yellow crystalline powder.

It is soluble in acetone, sparingly soluble in methanol, slightly soluble in ethanol (99.5), and practically insoluble in water.

Identification (1) To 1 mg of Acemetacin add 1 mL of concentrated chromotropic acid TS, and heat in a water bath for 5 minutes: a red-purple color develops.

(2) Determine the absorption spectrum of a solution of Acemetacin in methanol (1 in 50,000) as directed under Ultraviolet-visible Spectrophotometry <2.24>, and compare the spectrum with the Reference Spectrum: both spectra exhibit similar intensities of absorption at the same wavelengths.

(3) Determine the infrared absorption spectrum of Acemetacin as directed in the potassium bromide disk method under Infrared Spectrometry <2.25>, and compare the spectrum with the Reference Spectrum: both spectra exhibit similar intensities of absorption at the same wave

numbers.

(4) Perform the test with Acemetacin as directed under Flame Coloration Test <1.04> (2): a green color appears.

Melting point <2.60> 151 – 154°C

Purity (1) Heavy metals <1.07>—Proceed with 1.0 g of Acemetacin according to Method 4, and perform the test. Prepare the control solution with 2.0 mL of Standard Lead Solution (not more than 20 ppm).

(2) Related substances—Dissolve 0.40 g of Acemetacin in 10 mL of acetone, and use this solution as the sample solution. Pipet 1 mL of the sample solution, and add acetone to make exactly 50 mL. Pipet 1 mL of this solution, add acetone to make exactly 10 mL, and use this solution as the standard solution. Perform the test with these solutions as directed under Thin Layer Chromatography <2.03>. Spot 5 μ L each of the sample solution and standard solution on a plate of silica gel with fluorescent indicator for thin layer chromatography. Develop the plate with a mixture of hexane, 4-methyl-2-pentanone and acetic acid (100) (3:2:1) to a distance of about 10 cm, and air-dry the plate. Examine under ultraviolet light (main wavelength: 254 nm): the number of spots other than the principal spot obtained from the sample solution is not more than 2, and these spots are not more intense than the spot from the standard solution.

Loss on drying <2.41> Not more than 0.5% (1 g, 105°C, 2 hours).

Residue on ignition <2.44> Not more than 0.1% (1 g).

Assay Weigh accurately about 0.35 g of Acemetacin, previously dried, dissolve in 20 mL of acetone, add 10 mL of water, and then titrate <2.50> with 0.1 mol/L sodium hydroxide VS (potentiometric titration). Perform a blank determination in the same manner, and make any necessary correction.

$$\begin{aligned} \text{Each mL of 0.1 mol/L sodium hydroxide VS} \\ = 41.58 \text{ mg of } C_{21}H_{18}ClNO_6 \end{aligned}$$

Containers and storage Containers—Tight containers.

Acemetacin Capsules

アセメタシンカプセル

Acemetacin Capsules contain not less than 93.0% and not more than 107.0% of the labeled amount of acemetacin ($C_{21}H_{18}ClNO_6$; 415.82).

Method of preparation Prepare as directed under Capsules, with Acemetacin.

Identification To an amount of powdered contents of Acemetacin Capsules, equivalent to 0.1 g of Acemetacin, add 100 mL of methanol, shake well, and filter. Take 10 mL of the filtrate, and distil the methanol under reduced pressure. To the residue add 1 mL of methanol, shake well, centrifuge, and use the supernatant liquid as the sample solution. Separately, dissolve 10 mg of acemetacin in 1 mL of methanol, and use this solution as the standard solution. Perform the test with these solutions as directed under Thin-layer Chromatography <2.03>. Spot 2 μ L each of the sample solution and standard solution on a plate of silica gel with fluorescent indicator for thin-layer chromatography. Develop the plate with a mixture of hexane, 4-methyl-2-pentanone and acetic acid (100) (3:2:1) to a distance of about 10 cm, and air-dry the plate. Examine under ultraviolet light

(main wavelength: 254 nm): the spots obtained from the sample solution and standard solution show the same *R_f* value.

Uniformity of dosage units <6.02> Perform the test according to the following method: it meets the requirement of the Content uniformity test.

Take out the contents of 1 capsule of Acemetacin Capsules, add 40 mL of methanol, shake well, and add methanol to make exactly *V* mL so that each mL contains about 0.6 mg of acemetacin ($C_{21}H_{18}ClNO_6$). Filter this solution, discard the first 10 mL of the filtrate, pipet 5 mL of the subsequent filtrate, add exactly 2 mL of the internal standard solution, add methanol to make 50 mL, and use this solution as the sample solution. Proceed as directed in the Assay.

$$\begin{aligned} \text{Amount (mg) of acemetacin } (C_{21}H_{18}ClNO_6) \\ = M_S \times Q_T/Q_S \times V/50 \end{aligned}$$

M_S: Amount (mg) of acemetacin for assay taken

Internal standard solution—A solution of hexyl parahydroxybenzoate in methanol (1 in 1000).

Dissolution <6.10> When the test is performed at 50 revolutions per minute according to the Paddle method using the sinker, using 900 mL of 2nd fluid for dissolution test as the dissolution medium, the dissolution rate in 30 minutes of Acemetacin Capsules is not less than 70%.

Start the test with 1 capsule of Acemetacin Capsules, withdraw not less than 20 mL of the medium at the specified minute after starting the test, and filter through a membrane filter with a pore size not exceeding 0.45 μ m. Discard not less than 10 mL of the first filtrate, pipet *V* mL of the subsequent filtrate, add the dissolution medium to make exactly *V'* mL so that each mL contains about 33 μ g of acemetacin ($C_{21}H_{18}ClNO_6$), and use this solution as the sample solution. Separately, weigh accurately about 17 mg of acemetacin for assay, previously dried at 105°C for 2 hours, dissolve in the dissolution medium to make exactly 100 mL. Pipet 4 mL of this solution, add the dissolution medium to make exactly 20 mL, and use this solution as the standard solution. Determine the absorbances, *A_T* and *A_S*, of the sample solution and standard solution at 319 nm as directed under Ultraviolet-visible Spectrophotometry <2.24>.

$$\begin{aligned} \text{Dissolution rate (\%)} \text{ with respect to the labeled amount} \\ \text{of acemetacin } (C_{21}H_{18}ClNO_6) \\ = M_S \times A_T/A_S \times V'/V \times 1/C \times 180 \end{aligned}$$

M_S: Amount (mg) of acemetacin for assay taken

C: Labeled amount (mg) of acemetacin ($C_{21}H_{18}ClNO_6$) in 1 capsule

Assay Take out the contents of not less than 20 Acemetacin Capsules, weigh accurately the mass of the contents, and powder. Weigh accurately a portion of the powder, equivalent to about 30 mg of acemetacin ($C_{21}H_{18}ClNO_6$), add 40 mL of methanol, shake well, and add methanol to make exactly 50 mL. Filter this solution, discard the first 10 mL of the filtrate, pipet 5 mL of the subsequent filtrate, add exactly 2 mL of the internal standard solution, add methanol to make 50 mL, and use this solution as the sample solution. Separately, weigh accurately about 30 mg of acemetacin for assay, previously dried at 105°C for 2 hours, and dissolve in methanol to make exactly 50 mL. Pipet 5 mL of this solution, add exactly 2 mL of the internal standard solution, add methanol to make 50 mL, and use this solution as the standard solution. Perform the test with 20 μ L each of the sample solution and standard solution as directed under Liquid Chromatography <2.01> according to the following condi-

tions, and calculate the ratios, Q_T and Q_S , of the peak area of acemetacin to that of the internal standard.

$$\begin{aligned} \text{Amount (mg) of acemetacin (C}_{21}\text{H}_{18}\text{ClNO}_6\text{)} \\ = M_S \times Q_T/Q_S \end{aligned}$$

M_S : Amount (mg) of acemetacin for assay taken

Internal standard solution—A solution of hexyl parahydroxybenzoate in methanol (1 in 1000).

Operating conditions—

Detector: An ultraviolet absorption photometer (wavelength 254 nm).

Column: A stainless steel column 4.6 mm in inside diameter and 25 cm in length, packed with octadecylsilylated silica gel for liquid chromatography (5 μm in particle diameter).

Column temperature: A constant temperature of about 40°C.

Mobile phase: To 6 g of acetic acid (100) add water to make 1000 mL, and adjust the pH to 3.2 with a solution of 1.36 g of sodium acetate trihydrate in 100 mL of water. To 200 mL of this solution add 300 mL of acetonitrile.

Flow rate: Adjust so that the retention time of acemetacin is about 7 minutes.

System suitability—

System performance: Dissolve 75 mg of acemetacin and 75 mg of indometacin in 50 mL of methanol. To 2 mL of this solution add 2 mL of the internal standard solution, and add methanol to make 50 mL. When the procedure is run with 20 μL of this solution under the above operating conditions, acemetacin, indometacin and the internal standard are eluted in this order with the resolutions between the peaks of acemetacin and indometacin and between the peaks of indometacin and the internal standard being not less than 3, respectively.

System repeatability: When the test is repeated 6 times with 20 μL of the standard solution under the above operating conditions, the relative standard deviation of the ratio of the peak area of acemetacin to that of the internal standard is not more than 1.0%.

Containers and storage Containers—Tight containers.

Acemetacin Tablets

アセメタシン錠

Acemetacin Tablets contain not less than 93.0% and not more than 107.0% of the labeled amount of acemetacin (C₂₁H₁₈ClNO₆; 415.82).

Method of preparation Prepare as directed under Tablets, with Acemetacin.

Identification To a quantity of powdered Acemetacin Tablets, equivalent to 0.1 g of Acemetacin, add 100 mL of methanol, shake well, and filter. Take 10 mL of the filtrate, and distil the methanol under reduced pressure. Dissolve the residue in 1 mL of methanol, centrifuge, and use the supernatant liquid as the sample solution. Separately, dissolve 10 mg of acemetacin in 1 mL of methanol, and use this solution as the standard solution. Perform the test with these solutions as directed under Thin-layer Chromatography <2.03>. Spot 2 μL each of the sample solution and standard solution on a plate of silica gel with fluorescent indicator for thin-layer chromatography. Develop the plate with a mixture of hexane, 4-methyl-2-pentanone and acetic acid (100) (3:2:1) to a distance of about 10 cm, and air-dry the plate. Examine

under ultraviolet light (main wavelength: 254 nm): the spots obtained from the sample solution and standard solution show the same R_f value.

Uniformity of dosage units <6.02> Perform the test according to the following method: it meets the requirement of the Content uniformity test.

To 1 tablet of Acemetacin Tablets add 3 mL of water, and shake until the tablet is disintegrated. Add 15 mL of methanol, shake for 20 minutes, and add methanol to make exactly V mL so that each mL contains about 1.2 mg of acemetacin (C₂₁H₁₈ClNO₆). Centrifuge this solution, filter the supernatant liquid, discard the first 10 mL of the filtrate, pipet 5 mL of the subsequent filtrate, add exactly 1 mL of the internal standard solution, add methanol to make 50 mL, and use this solution as the sample solution. Proceed as directed in the Assay.

$$\begin{aligned} \text{Amount (mg) of acemetacin (C}_{21}\text{H}_{18}\text{ClNO}_6\text{)} \\ = M_S \times Q_T/Q_S \times V/25 \end{aligned}$$

M_S : Amount (mg) of acemetacin for assay taken

Internal standard solution—A solution of hexyl parahydroxybenzoate in methanol (1 in 250).

Dissolution <6.10> When the test is performed at 50 revolutions per minute according to the Paddle method, using 900 mL of 2nd fluid for dissolution test as the dissolution medium, the dissolution rate in 45 minutes of Acemetacin Tablets is not less than 80%.

Start the test with 1 tablet of Acemetacin Tablets, withdraw not less than 20 mL of the medium at the specified minute after starting the test, and filter through a membrane filter with a pore size not exceeding 0.45 μm . Discard not less than 10 mL of the first filtrate, pipet V mL of the subsequent filtrate, add the dissolution medium to make exactly V' mL so that each mL contains about 33 μg of acemetacin (C₂₁H₁₈ClNO₆), and use this solution as the sample solution. Separately, weigh accurately about 17 mg of acemetacin for assay, previously dried at 105°C for 2 hours, dissolve in the dissolution medium to make exactly 100 mL. Pipet 4 mL of this solution, add the dissolution medium to make exactly 20 mL, and use this solution as the standard solution. Determine the absorbances, A_T and A_S , of the sample solution and standard solution at 319 nm as directed under Ultraviolet-visible Spectrophotometry <2.24>.

Dissolution rate (%) with respect to the labeled amount of acemetacin (C₂₁H₁₈ClNO₆)

$$= M_S \times A_T/A_S \times V'/V \times 1/C \times 180$$

M_S : Amount (mg) of acemetacin for assay taken

C : Labeled amount (mg) of acemetacin (C₂₁H₁₈ClNO₆) in 1 tablet

Assay Weigh accurately the mass of not less than 20 Acemetacin Tablets, and powder. Weigh accurately a portion of the powder, equivalent to about 0.6 g of acemetacin (C₂₁H₁₈ClNO₆), add 120 mL of methanol, shake for 20 minutes, and add methanol to make exactly 200 mL. Centrifuge this solution, filter the supernatant liquid, discard the first 10 mL of the filtrate, pipet 2 mL of the subsequent filtrate, add exactly 1 mL of the internal standard solution, add methanol to make 50 mL, and use this solution as the sample solution. Separately, weigh accurately about 30 mg of acemetacin for assay, previously dried at 105°C for 2 hours, and dissolve in methanol to make exactly 25 mL. Pipet 5 mL of this solution, add exactly 1 mL of the internal standard solution, add methanol to make 50 mL, and use this solution as the standard solution. Perform the test with

10 μ L each of the sample solution and standard solution as directed under Liquid Chromatography <2.01> according to the following conditions, and calculate the ratios, Q_T and Q_S , of the peak area of acetaminophen to that of the internal standard.

$$\begin{aligned} \text{Amount (mg) of acetaminophen (C}_{21}\text{H}_{18}\text{ClNO}_6) \\ = M_S \times Q_T / Q_S \times 20 \end{aligned}$$

M_S : Amount (mg) of acetaminophen for assay taken

Internal standard solution—A solution of hexyl parahydroxybenzoate in methanol (1 in 250).

Operating conditions—

Detector: An ultraviolet absorption photometer (wavelength 254 nm).

Column: A stainless steel column 4.6 mm in inside diameter and 25 cm in length, packed with octadecylsilanized silica gel for liquid chromatography (5 μ m in particle diameter).

Column temperature: A constant temperature of about 40°C.

Mobile phase: To 6 g of acetic acid (100) add water to make 1000 mL, and adjust the pH to 3.2 with a solution of 1.36 g of sodium acetate trihydrate in 100 mL of water. To 200 mL of this solution add 300 mL of acetonitrile.

Flow rate: Adjust so that the retention time of acetaminophen is about 7 minutes.

System suitability—

System performance: Dissolve 75 mg of acetaminophen and 75 mg of indometacin in 50 mL of methanol. To 4 mL of this solution add 1 mL of the internal standard solution, and add methanol to make 50 mL. When the procedure is run with 10 μ L of this solution under the above operating conditions, acetaminophen, indometacin and the internal standard are eluted in this order with the resolutions between the peaks of acetaminophen and indometacin and between the peaks of indometacin and the internal standard being not less than 3, respectively.

System repeatability: When the test is repeated 6 times with 10 μ L of the standard solution under the above operating conditions, the relative standard deviation of the ratio of the peak area of acetaminophen to that of the internal standard is not more than 1.0%.

Containers and storage Containers—Tight containers.

Acetaminophen

Paracetamol

アセトアミノフェン

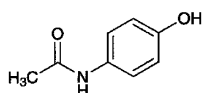

$C_8H_9NO_2$: 151.16

N-(4-Hydroxyphenyl)acetamide

[103-90-2]

Acetaminophen, when dried, contains not less than 98.0% of acetaminophen ($C_8H_9NO_2$).

Description Acetaminophen occurs as white, crystals or crystalline powder.

It is freely soluble in methanol and in ethanol (95), sparingly soluble in water, and very slightly, soluble in diethyl ether.

It dissolves in sodium hydroxide TS.

Identification Determine the infrared absorption spectra of Acetaminophen, previously dried, as directed in the potassium bromide disk method under Infrared Spectrophotometry <2.25>, and compare the spectrum with the Reference Spectrum or the spectrum of dried Acetaminophen RS: both spectra exhibit similar intensities of absorption at the same wave numbers.

Melting point <2.60> 169 – 172°C

Purity (1) Chloride <1.03>—Dissolve 4.0 g of Acetaminophen in 100 mL of water by heating, cool with shaking in ice water, allow to stand until ordinary temperature is attained, add water to make 100 mL, and filter. To 25 mL of the filtrate add 6 mL of dilute nitric acid and water to make 50 mL, and perform the test using this solution as the test solution. Prepare the control solution with 0.40 mL of 0.01 mol/L hydrochloric acid VS (not more than 0.014%).

(2) Sulfate <1.14>—To 25 mL of the filtrate obtained in (1) add 1 mL of dilute hydrochloric acid and water to make 50 mL, and perform the test using this solution as the test solution. Prepare the control solution with 0.40 mL of 0.005 mol/L sulfuric acid VS (not more than 0.019%).

(3) Heavy metals <1.07>—Proceed with 2.0 g of Acetaminophen according to Method 4, and perform the test. Prepare the control solution with 2.0 mL of Standard Lead Solution (not more than 10 ppm).

(4) Arsenic <1.11>—Prepare the test solution with 1.0 g of Acetaminophen according to Method 3, and perform the test (not more than 2 ppm).

(5) Related substances—Dissolve 50 mg of Acetaminophen in 1 mL of methanol, add the mobile phase to make 50 mL, and use this solution as the sample solution. Pipet 1 mL of the sample solution, add the mobile phase to make exactly 200 mL, and use this solution as the standard solution. Perform the test with exactly 10 μ L each of the sample solution and standard solution as directed under Liquid Chromatography <2.01> according to the following conditions. Determine each peak area of both solutions by the automatic integration method: the total area of all peaks other than acetaminophen obtained from the sample solution is not larger than the peak area of acetaminophen from the standard solution.

Operating conditions—

Detector: An ultraviolet absorption photometer (wavelength: 225 nm).

Column: A stainless steel column about 4 mm in inside diameter and about 15 cm in length, packed with octadecylsilanized silica gel for liquid chromatography (5 μ m in particle diameter).

Column temperature: A constant temperature of about 40°C.

Mobile phase: A mixture of 0.05 mol/L potassium dihydrogenphosphate (pH 4.7) and methanol (4:1).

Flow rate: Adjust so that the retention time of acetaminophen is about 5 minutes.

Selection of column: Dissolve 0.01 g each of Acetaminophen and 4-aminophenol hydrochloride in 1 mL of methanol, add the mobile phase to make 50 mL, to 1 mL of this solution add the mobile phase to make 10 mL. Proceed with 10 μ L of this solution under the above operating conditions, and calculate the resolution. Use a column giving elution of 4-aminophenol and acetaminophen in this order with the resolution between these peaks being not less than 7.

Detection sensitivity: Adjust the detection sensitivity so that the peak height of acetaminophen obtained from 10 μ L

of the standard solution is about 15% of the full scale.

Time span of measurement: About 6 times as long as the retention time of acetaminophen, beginning after the solvent peak.

Loss on drying <2.41> Not more than 0.3% (0.5 g, 105°C, 2 hours).

Residue on ignition <2.44> Not more than 0.1% (1 g).

Assay Weigh accurately about 20 mg each of Acetaminophen and Acetaminophen RS, previously dried, dissolve in 2 mL of methanol, and add water to make exactly 100 mL. Pipet 3 mL each of these solutions, add water to make exactly 100 mL, and use these solutions as the sample solution and the standard solution, respectively. Determine the absorbances, A_T and A_S , of the sample solution and standard solution at the wavelength of maximum absorption at about 244 nm as directed under Ultraviolet-visible Spectrophotometry <2.24>, using water as the blank.

$$\begin{aligned} \text{Amount (mg) of acetaminophen (C}_8\text{H}_9\text{NO}_2\text{)} \\ = M_S \times A_T/A_S \end{aligned}$$

M_S : Amount (mg) of Acetaminophen RS taken

Containers and storage Containers—Tight containers.

Storage—Light-resistant.

Acetazolamide

アセタゾラミド

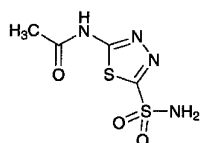

$\text{C}_4\text{H}_6\text{N}_4\text{O}_3\text{S}_2$: 222.25

N-(5-Sulfamoyl-1,3,4-thiadiazol-2-yl)acetamide
[59-66-5]

Acetazolamide contains not less than 98.0% and not more than 102.0% of acetazolamide ($\text{C}_4\text{H}_6\text{N}_4\text{O}_3\text{S}_2$), calculated on the dried basis.

Description Acetazolamide occurs as a white to pale yellow-white crystalline powder. It is odorless, and has a slight bitter taste.

It is slightly soluble in ethanol (95), very slightly soluble in water, and practically insoluble in diethyl ether.

Melting point: about 255°C (with decomposition).

Identification (1) To 0.1 g of Acetazolamide add 5 mL of sodium hydroxide TS, then add 5 mL of a solution of 0.1 g of hydroxylammonium chloride and 0.05 g of copper (II) sulfate pentahydrate in 10 mL of water: a light yellow color develops. Then heat this solution for 5 minutes: a deep yellow color is produced gradually.

(2) To 0.02 g of Acetazolamide add 2 mL of dilute hydrochloric acid, boil for 10 minutes, cool, and add 8 mL of water: this solution responds to Qualitative Tests <1.09> for primary aromatic amines.

(3) To 0.2 g of Acetazolamide add 0.5 g of granulated zinc and 5 mL of diluted hydrochloric acid (1 in 2): the gas evolved darkens moistened lead (II) acetate paper.

Purity (1) Clarity and color of solution—Dissolve 1.0 g of Acetazolamide in 10 mL of sodium hydroxide TS: the solution is clear and colorless to pale yellow.

(2) Chloride <1.03>—To 1.5 g of Acetazolamide add 75 mL of water, and warm at 70°C for 20 minutes with occasional shaking. After cooling, filter, and to 25 mL of the filtrate add 6 mL of dilute nitric acid and water to make 50 mL. Perform the test using this solution as the test solution. Prepare the control solution with 0.20 mL of 0.01 mol/L hydrochloric acid VS (not more than 0.014%).

(3) Sulfate <1.14>—To 25 mL of the filtrate obtained in (2) add 1 mL of dilute hydrochloric acid and water to make 50 mL. Perform the test using this solution as the test solution. Prepare the control solution with 0.40 mL of 0.005 mol/L sulfuric acid VS (not more than 0.038%).

(4) Heavy metals <1.07>—Proceed with 1.0 g of Acetazolamide according to Method 2, and perform the test. Prepare the control solution with 2.0 mL of Standard Lead Solution (not more than 20 ppm).

(5) Silver-reducing substances—Wet 5 g of Acetazolamide with 5 mL of aldehyde-free ethanol, and add 125 mL of water, 10 mL of nitric acid and exactly 5 mL of 0.1 mol/L silver nitrate VS. Stir for 30 minutes by protecting from light, filter through a glass filter (G3), and wash the residue on the glass filter with two 10-mL portions of water. Combine the filtrate with the washings, to the solution add 5 mL of ammonium iron (III) sulfate TS, and titrate <2.50> with 0.1 mol/L ammonium thiocyanate VS: not less than 4.8 mL of 0.1 mol/L ammonium thiocyanate VS is consumed.

Loss on drying <2.41> Not more than 0.5% (0.5 g, 105°C, 3 hours).

Residue on ignition <2.44> Not more than 0.1% (0.5 g).

Assay Weigh accurately about 0.15 g of Acetazolamide, and dissolve in 400 mL of water in a water bath by heating. After cooling, add water to make exactly 1000 mL. Pipet 5 mL of the solution, add 10 mL of 1 mol/L hydrochloric acid TS, and then add water to make exactly 100 mL. Determine the absorbance A of this solution at the wavelength of maximum absorption at about 265 nm as directed under Ultraviolet-visible Spectrophotometry <2.24>.

$$\begin{aligned} \text{Amount (mg) of acetazolamide (C}_4\text{H}_6\text{N}_4\text{O}_3\text{S}_2\text{)} \\ = A/474 \times 200,000 \end{aligned}$$

Containers and storage Containers—Well-closed containers.

Storage—Light-resistant.

Acetic Acid

酢酸

Acetic Acid contains not less than 30.0 w/v% and not more than 32.0 w/v% of acetic acid ($\text{C}_2\text{H}_4\text{O}_2$: 60.05).

Description Acetic Acid is a clear, colorless liquid. It has a pungent, characteristic odor and an acid taste.

It is miscible with water, with ethanol (95) and with glycerin.

Specific gravity d_{20}^{20} : about 1.04

Identification Acetic Acid changes blue litmus paper to red, and responds to Qualitative Tests <1.09> for acetate.

Purity (1) Chloride—To 20 mL of Acetic Acid add 40 mL of water, and use this solution as the sample solution. To 10 mL of the sample solution add 5 drops of silver nitrate TS: no opalescence is produced.

(2) Sulfate—To 10 mL of the sample solution obtained in (1) add 1 mL of barium chloride TS: no turbidity is produced.

(3) Heavy metals <1.07>—Evaporate 10 mL of Acetic Acid on a water bath to dryness, and to the residue add 2 mL of dilute acetic acid and water to make 50 mL. Perform the test with this solution as the test solution. Prepare the control solution with 3.0 mL of Standard Lead Solution by adding 2 mL of dilute acetic acid and water to make 50 mL (not more than 3 ppm).

(4) Potassium permanganate-reducing substances—To 20 mL of the sample solution obtained in (1) add 0.10 mL of 0.02 mol/L potassium permanganate VS: the red color does not disappear within 30 minutes.

(5) Non-volatile residue—Evaporate 30 mL of Acetic Acid on a water bath to dryness, and dry at 105°C for 1 hour: the mass of the residue is not more than 1.0 mg.

Assay Measure exactly 5 mL of Acetic Acid, add 30 mL of water, and titrate <2.50> with 1 mol/L sodium hydroxide VS (indicator: 2 drops of phenolphthalein TS).

Each mL of 1 mol/L sodium hydroxide VS
= 60.05 mg of C₂H₄O₂

Containers and storage Containers—Tight containers.

Glacial Acetic Acid

氷酢酸

H₃C—CO₂H

C₂H₄O₂: 60.05

Acetic acid

[64-19-7]

Glacial Acetic Acid contains not less than 99.0% of acetic acid (C₂H₄O₂).

Description Glacial Acetic Acid is a clear, colorless, volatile liquid, or colorless or white, crystalline masses. It has a pungent, characteristic odor.

It is miscible with water, with ethanol (95) and with diethyl ether.

Boiling point: about 118°C

Specific gravity *d*₂₀²⁰: about 1.049

Identification A solution of Glacial Acetic Acid (1 in 3) changes blue litmus paper to red, and responds to Qualitative Tests <1.09> for acetate.

Congealing point <2.42> Not less than 14.5°C.

Purity (1) Chloride—To 10 mL of Glacial Acetic Acid add water to make 100 mL, and use this solution as the sample solution. To 10 mL of the sample solution add 5 drops of silver nitrate TS: no opalescence is produced.

(2) Sulfate—To 10 mL of the sample solution obtained in (1) add 1 mL of barium chloride TS: no turbidity is produced.

(3) Heavy metals <1.07>—Evaporate 2.0 mL of Glacial Acetic Acid on a water bath to dryness. Dissolve the residue in 2 mL of dilute acetic acid and water to make 50 mL, and perform the test using this solution as the test solution. Prepare the control solution with 2.0 mL of Standard Lead Solution by adding 2.0 mL of dilute acetic acid and water to make 50 mL (not more than 10 ppm).

(4) Potassium permanganate-reducing substances—To 20 mL of the sample solution obtained in (1) add 0.10 mL of

0.02 mol/L potassium permanganate VS: the red color does not disappear within 30 minutes.

(5) Non-volatile residue—Evaporate 10 mL of Glacial Acetic Acid on a water bath to dryness, and dry at 105°C for 1 hour: the mass of the residue is not more than 1.0 mg.

Assay Place 10 mL of water in a glass-stoppered flask, and weigh accurately. Add about 1.5 g of Glacial Acetic Acid, weigh accurately again, then add 30 mL of water, and titrate <2.50> with 1 mol/L sodium hydroxide VS (indicator: 2 drops of phenolphthalein TS).

Each mL of 1 mol/L sodium hydroxide VS
= 60.05 mg of C₂H₄O₂

Containers and storage Containers—Tight containers.

Acetohexamide

アセトヘキサミド

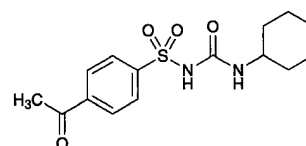

C₁₅H₂₀N₂O₄S: 324.40

4-Acetyl-*N*-(cyclohexylcarbonyl)benzenesulfonamide

[968-81-0]

Acetohexamide, when dried, contains not less than 98.0% and not more than 101.0% of acetohexamide (C₁₅H₂₀N₂O₄S).

Description Acetohexamide occurs as a white to yellowish white powder.

It is freely soluble in *N,N*-dimethylformamide, sparingly soluble in acetone, slightly soluble in methanol and in ethanol (99.5), and practically insoluble in water.

Melting point: about 185°C (with decomposition).

Identification (1) Dissolve 0.10 g of Acetohexamide in 100 mL of methanol. To 5 mL of the solution add 20 mL of 0.5 mol/L hydrochloric acid TS and 75 mL of methanol, and use the solution as the sample solution (1). Determine the absorption spectrum of the sample solution (1) as directed under Ultraviolet-visible Spectrophotometry <2.24>, using methanol as the blank, and compare the spectrum with the Reference Spectrum 1: both spectra exhibit similar intensities of absorption at the same wavelengths. Separately, to exactly 10 mL of the sample solution (1) add methanol to make exactly 50 mL, and use the solution as the sample solution (2). Determine the absorption spectrum of the sample solution (2) as directed under Ultraviolet-visible Spectrophotometry <2.24>, using methanol as the blank, and compare the spectrum with the Reference Spectrum 2: both spectra exhibit similar intensities of absorption at the same wavelengths.

(2) Determine the infrared absorption spectrum of Acetohexamide, previously dried, as directed in the potassium bromide disk method under Infrared Spectrophotometry <2.25>, and compare the spectrum with the Reference Spectrum: both spectra exhibit similar intensities of absorption at the same wave numbers.

Purity (1) Chloride <1.03>—Dissolve 1.5 g of Acetohexamide in 40 mL of *N,N*-dimethylformamide, add 6 mL of dilute nitric acid and *N,N*-dimethylformamide to make 50 mL. Perform the test using this solution as the test solution.

Prepare the control solution as follows: to 0.45 mL of 0.01 mol/L hydrochloric acid VS add 6 mL of dilute nitric acid and *N,N*-dimethylformamide to make 50 mL (not more than 0.011%).

(2) Sulfate <1.14>—Dissolve 2.0 g of Acetohexamide in 40 mL of *N,N*-dimethylformamide, and add 1 mL of dilute hydrochloric acid and *N,N*-dimethylformamide to make 50 mL. Perform the test using this solution as the test solution. Prepare the control solution as follows: to 0.40 mL of 0.005 mol/L sulfuric acid VS add 1 mL of dilute hydrochloric acid and *N,N*-dimethylformamide to make 50 mL (not more than 0.010%).

(3) Heavy metals <1.07>—Proceed with 1.0 g of Acetohexamide according to Method 2, and perform the test. Prepare the control solution with 2.0 mL of Standard Lead Solution (not more than 20 ppm).

(4) Related substances (i) Cyclohexylamine—Dissolve exactly 1.0 g of Acetohexamide in exactly 30 mL of 0.5 mol/L sodium hydroxide TS, add exactly 5 mL of hexane, shake vigorously for 60 minutes, allow to stand for 5 minutes, and use the upper layer as the sample solution. Separately, dissolve exactly 50 mg of cyclohexylamine in 0.5 mol/L sodium hydroxide TS to make exactly 50 mL. Pipet 2 mL of this solution, and add 0.5 mol/L sodium hydroxide TS to make exactly 300 mL. Pipet 30 mL of this solution, add exactly 5 mL of hexane, shake vigorously for 60 minutes, allow to stand for 5 minutes, and use the upper layer as the standard solution. Perform the test with exactly 2 μ L each of the sample solution and standard solution as directed under Gas Chromatography <2.02> according to the following conditions, and determine the peak area of cyclohexylamine by the automatic integration method: the peak area of cyclohexylamine obtained from the sample solution is not more than that from the standard solution.

Operating conditions—

Detector: A hydrogen flame-ionization detector.

Column: A fused-silica column 0.53 mm in inside diameter and 30 m in length, coated the inner surface with methylsilicone polymer for gas chromatography 1.5 μ m in thickness.

Column temperature: A constant temperature of about 90°C.

Injection port temperature: A constant temperature of about 150°C.

Detector temperature: A constant temperature of about 210°C.

Carrier gas: Helium.

Flow rate: Adjust so that the retention time of cyclohexylamine is about 4 minutes.

Split ratio: 1:1.

System suitability—

System performance: When the procedure is run with 2 μ L of the standard solution under the above operating conditions, the number of theoretical plates of the peak of cyclohexylamine is not less than 8000.

System repeatability: When the test is repeated 6 times with 2 μ L of the standard solution under the above operating conditions, the relative standard deviation of the peak area of cyclohexylamine is not more than 5%.

(ii) Dicyclohexylurea—Dissolve exactly 1.0 g of Acetohexamide in exactly 10 mL of 0.5 mol/L sodium hydroxide TS, add exactly 20 mL of methanol, shake, then add exactly 5 mL of diluted hydrochloric acid (1 in 10), shake vigorously for 15 minutes, and centrifuge. Filter 10 mL or more of the supernatant liquid through a membrane filter with pore size of not larger than 0.5 μ m. Discard the first 5 mL of the filtrate, and use the subsequent filtrate as the sample solution.

Separately, dissolve exactly 50 mg of dicyclohexylurea in methanol to make exactly 100 mL. Pipet 2 mL of this solution, and add methanol to make exactly 100 mL. Pipet 20 mL of this solution, add exactly 10 mL of 0.5 mol/L sodium hydroxide TS, shake, then add exactly 5 mL of diluted hydrochloric acid (1 in 10), shake, and use this solution as the standard solution. Perform the test with exactly 50 μ L each of the sample solution and standard solution as directed under Liquid Chromatography <2.01> according to the following conditions, and determine the peak area of dicyclohexylurea by the automatic integration method: the peak area of dicyclohexylurea obtained from the sample solution is not more than that from the standard solution.

Operating conditions—

Detector: An ultraviolet absorption photometer (wavelength: 210 nm).

Column: A stainless steel column 4.6 mm in inside diameter and 25 cm in length, packed with octadecylsilanized silica gel for liquid chromatography (5 μ m in particle diameter).

Column temperature: A constant temperature of about 25°C.

Mobile phase: Dissolve 0.5 g of sodium hydroxide in 1000 mL of 0.05 mol/L sodium dihydrogen phosphate TS, and adjust the pH to 6.5 with 0.5 mol/L sodium hydroxide TS. To 500 mL of this solution add 500 mL of acetonitrile.

Flow rate: Adjust so that the retention time of dicyclohexylurea is about 10 minutes.

System suitability—

System performance: When the procedure is run with 50 μ L of the standard solution under the above operating conditions, the number of theoretical plates of the peak of dicyclohexylurea is not less than 10,000.

System repeatability: When the test is repeated 6 times with 50 μ L of the standard solution under the above operating conditions, the relative standard deviation of the peak area of dicyclohexylurea is not more than 2.0%.

(iii) Other related substances—Dissolve 0.10 g of Acetohexamide in 10 mL of acetone, and use this solution as the sample solution. Pipet 1 mL of the sample solution, and add acetone to make exactly 20 mL. Pipet two 1 mL portions of this solution, add acetone to make exactly 10 mL and 25 mL, respectively, and use these solutions as the standard solution (1) and the standard solution (2). Perform the test with these solutions as directed under Thin-layer Chromatography <2.03>. Spot 10 μ L each of the sample solution and standard solutions (1) and (2) on a plate of silica gel with fluorescent indicator for thin-layer chromatography. Develop the plate with a mixture of ethyl acetate, methanol, ammonia solution (28) and cyclohexane (6:2:1:1) to a distance of about 10 cm, and air-dry the plate. Examine under ultraviolet light (main wavelength: 254 nm): the spots other than the principal spot obtained from the sample solution are not more intense than the spot from the standard solution (1), and the number of them which are more intense than the spot from the standard solution (2) is not more than 4.

Loss on drying <2.41> Not more than 1.0% (1 g, 105°C, 4 hours).

Residue on ignition <2.44> Not more than 0.1% (1 g).

Assay Weigh accurately about 0.3 g of Acetohexamide, previously dried, dissolve in 30 mL of *N,N*-dimethylformamide, add 10 mL of water, and titrate <2.50> with 0.1 mol/L sodium hydroxide VS (potentiometric titration). Perform a blank determination in the same manner using a solution prepared by adding 19 mL of water to 30 mL of *N,N*-dimethylformamide, and make any necessary correc-

tion.

Each mL of 0.1 mol/L sodium hydroxide VS
= 32.44 mg of $C_{15}H_{20}N_2O_4S$

Containers and storage Containers—Well-closed containers.

Acetylcholine Chloride for Injection

注射用アセチルコリン塩化物

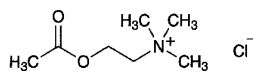

$C_7H_{16}ClNO_2$: 181.66

2-Acetoxy-*N,N,N*-trimethylethylamminium chloride
[60-31-1]

Acetylcholine Chloride for Injection is a preparation for injection which is dissolved before use.

It contains not less than 98.0% and not more than 102.0% of acetylcholine chloride ($C_7H_{16}ClNO_2$), and not less than 19.3% and not more than 19.8% of chlorine (Cl: 35.45), calculated on the dried basis.

It contains not less than 93.0% and not more than 107.0% of the labeled amount of acetylcholine chloride ($C_7H_{16}ClNO_2$).

Method of preparation Prepare as directed under Injections.

Description Acetylcholine Chloride for Injection occurs as white, crystals or crystalline powder.

It is very soluble in water, and freely soluble in ethanol (95).

It is extremely hygroscopic.

Identification (1) Determine the infrared absorption spectrum of Acetylcholine Chloride for Injection, previously dried, as directed in the potassium bromide disk method under Infrared Spectrophotometry <2.25>, and compare the spectrum with the Reference Spectrum: both spectra exhibit similar intensities of absorption at the same wave numbers.

(2) A solution of Acetylcholine Chloride for Injection (1 in 10) responds to Qualitative Tests <1.09> (2) for chloride.

Melting point <2.60> 149 – 152°C. Seal Acetylcholine Chloride for Injection in a capillary tube for melting point immediately after drying both of the sample and the tube at 105°C for 3 hours, and determine the melting point.

Purity (1) Clarity and color of solution—Dissolve 1.0 g of Acetylcholine Chloride for Injection in 10 mL of water: the solution is clear and colorless.

(2) Acidity—Dissolve 0.10 g of Acetylcholine Chloride for Injection in 10 mL of freshly boiled and cooled water, and add 1 drop of bromothymol blue TS, and 0.30 mL of 0.01 mol/L sodium hydroxide VS: the solution is blue in color.

(3) Heavy metals <1.07>—Proceed with 2.0 g of Acetylcholine Chloride for Injection according to Method 1, and perform the test. Prepare the control solution with 2.0 mL of Standard Lead Solution (not more than 10 ppm).

Loss on drying <2.41> Not more than 1.0% (1 g, 105°C, 3 hours).

Residue on ignition <2.44> Not more than 0.1% (1 g).

Uniformity of dosage units <6.02> It meets the requirement

of the Mass variation test.

Foreign insoluble matter <6.06> Perform the test according to Method 2: it meets the requirement.

Insoluble particulate matter <6.07> It meets the requirement.

Sterility <4.06> Perform the test according to the Membrane filtration method: it meets the requirement.

Assay (1) Acetylcholine chloride—Weigh accurately the contents of not less than 10 Acetylcholine Chloride for Injections. Weigh accurately about 0.5 g of the contents, dissolve in 15 mL of water, then add exactly 40 mL of 0.1 mol/L sodium hydroxide VS, stopper loosely, and heat on a water bath for 30 minutes. Cool quickly, and titrate <2.50> the excess sodium hydroxide with 0.05 mol/L sulfuric acid VS (indicator: 3 drops of phenolphthalein TS). Perform a blank determination in the same manner.

Each mL of 0.1 mol/L sodium hydroxide VS
= 18.17 mg of $C_7H_{16}ClNO_2$

(2) Chlorine—Titrate <2.50> the solution, which has been titrated in (1), with 0.1 mol/L silver nitrate VS (indicator: 3 drops of fluorescein sodium TS).

Each mL of 0.1 mol/L silver nitrate VS
= 3.545 mg of Cl

Containers and storage Containers—Hermetic containers.

Acetylcysteine

アセチルシステイン

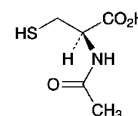

$C_5H_9NO_3S$: 163.19

(2*R*)-2-Acetylamino-3-sulfanylpropanoic acid
[616-91-1]

Acetylcysteine contains not less than 99.0% and not more than 101.0% of acetylcysteine ($C_5H_9NO_3S$), calculated on the dried basis.

Description Acetylcysteine occurs as white, crystals or crystalline powder.

It is freely soluble in water and in ethanol (99.5).

It dissolves in sodium hydroxide TS.

Identification Determine the infrared absorption spectrum of Acetylcysteine as directed in the potassium bromide disk method under Infrared Spectrophotometry <2.25>, and compare the spectrum with the Reference Spectrum: both spectra exhibit similar intensities of absorption at the same wave numbers.

Optical rotation <2.49> $[\alpha]_D^{20}$: +21.0 – +27.0° Weigh accurately an amount of Acetylcysteine, equivalent to about 2.5 g calculated on the dried basis, and dissolve with 2 mL of a solution of disodium dihydrogen ethylenediamine tetraacetate dihydrate (1 in 100) and 15 mL of a solution of sodium hydroxide (1 in 25). To this solution add a solution, prepared by adjusting the pH to 7.0 of 500 mL of a solution of potassium dihydrogen phosphate (17 in 125) with sodium hydroxide TS and adding water to make 1000 mL, to make exactly 50 mL. Determine the optical rotation of this solution using

a 100-mm cell.

Melting point <2.60> 107 – 111°C

Purity (1) Chloride <1.03>—Dissolve 0.40 g of Acetylcysteine in 25 mL of sodium hydroxide TS, add 4 mL of hydrogen peroxide (30), heat in a water bath for 45 minutes, and cool. Then add 5 mL of nitric acid, add water to make 50 mL, and perform the test using this solution as the test solution. Prepare the control solution with 0.45 mL of 0.01 mol/L hydrochloric acid VS (not more than 0.040%).

(2) **Sulfate** <1.14>—Perform the test with 0.8 g of Acetylcysteine. Prepare the control solution with 0.50 mL of 0.005 mol/L sulfuric acid VS (not more than 0.030%).

(3) **Ammonium** <1.02>—Perform the test with 0.10 g of Acetylcysteine, using the distillation under reduced pressure. Prepare the control solution with 2.0 mL of Standard Ammonium Solution (not more than 0.02%).

(4) **Heavy metals** <1.07>—Dissolve 1.0 g of Acetylcysteine in 40 mL of water, add 3 mL of sodium hydroxide TS, 2 mL of dilute acetic acid and water to make 50 mL, and perform the test using this solution as the test solution. Prepare the control solution as follows: To 1.0 mL of Standard Lead Solution add 2 mL of dilute acetic acid and water to make 50 mL (not more than 10 ppm).

(5) **Iron** <1.10>—Prepare the test solution with 1.0 g of Acetylcysteine according to Method 1, and perform the test according to Method A. Prepare the control solution with 1.0 mL of Standard Iron Solution (not more than 10 ppm).

(6) **Related substances**—Dissolve 50 mg of Acetylcysteine in 25 mL of the mobile phase, and use this solution as the sample solution. The sample solution is prepared before using. Perform the test with 10 µL of the sample solution as directed under Liquid Chromatography <2.01> according to the following conditions, determine each peak area by the automatic integration method, and calculate their amounts by the area percentage method: the area of the peak other than acetylcysteine is not more than 0.3%, and the total area of the peak other than acetylcysteine is not more than 0.6%.

Operating conditions—

Detector: An ultraviolet absorption photometer (wavelength: 220 nm).

Column: A stainless steel column 4.6 mm in inside diameter and 25 cm in length, packed with octadecylsilanized silica gel for liquid chromatography (5 µm in particle diameter).

Column temperature: A constant temperature of about 40°C.

Mobile phase: A mixture of diluted phosphoric acid (1 in 2500) and acetonitrile (19:1).

Flow rate: Adjust so that the retention time of acetylcysteine is about 7 minutes.

Time span of measurement: About 4 times as long as the retention time of acetylcysteine, beginning after the solvent peak.

System suitability—

Test for required detectability: To 1 mL of the sample solution add the mobile phase to make 10 mL. To 1 mL of this solution, add the mobile phase to make 20 mL, and use this solution as the solution for system suitability test. Pipet 5 mL of the solution for system suitability test, and add the mobile phase to make exactly 25 mL. Confirm that the peak area of acetylcysteine obtained with 10 µL of this solution is equivalent to 15 to 25% of that with 10 µL of the solution for system suitability test.

System performance: When the procedure is run with 10 µL of the solution for system suitability test under the above operating conditions, the number of theoretical plates and

the symmetry factor of the peak of acetylcysteine are not less than 15,000 and not more than 1.5, respectively.

System repeatability: When the test is repeated 6 times with 10 µL of the solution for system suitability test under the above operating conditions, the relative standard deviation of the peak area of acetylcysteine is not more than 2.0%.

Loss on drying <2.41> Not more than 0.5% (1 g, 80°C, 3 hours).

Residue on ignition <2.44> Not more than 0.3% (1 g).

Assay Weigh accurately about 0.2 g of Acetylcysteine, place it in a stoppered flask, dissolve in 20 mL of water, add 4 g of potassium iodide and 5 mL of dilute hydrochloric acid, then add exactly 25 mL of 0.05 mol/L iodine VS, stopper tightly, allow to stand for 20 minutes in an ice cold water in the dark, and titrate <2.50> the excess of iodine with 0.1 mol/L sodium thiosulfate VS (indicator: 1 mL of starch TS). Perform a blank determination in the same manner.

Each mL of 0.05 mol/L iodine VS
= 16.32 mg of C₈H₁₁N₅O₃

Containers and storage Containers—Tight containers.

Aciclovir

アシクロビル

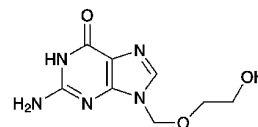

C₈H₁₁N₅O₃: 225.20

2-Amino-9-[(2-hydroxyethoxy)methyl]-1,9-dihydro-6H-purin-6-one
[59277-89-3]

Aciclovir contains not less than 98.5% and not more than 101.0% of aciclovir (C₈H₁₁N₅O₃), calculated on the anhydrous basis.

Description Aciclovir occurs as a white to pale yellow-white crystalline powder.

It is slightly soluble in water and very slightly soluble in ethanol (99.5).

It dissolves in 0.1 mol/L hydrochloric acid TS and in dilute sodium hydroxide TS.

Identification (1) Determine the absorption spectrum of a solution of Aciclovir in 0.1 mol/L hydrochloric acid TS (1 in 100,000) as directed under Ultraviolet-visible Spectrophotometry <2.24>, and compare the spectrum with the Reference Spectrum or the spectrum of a solution of Aciclovir RS prepared in the same manner as the sample solution: both spectra exhibit similar intensities of absorption at the same wavelengths.

(2) Determine the infrared absorption spectrum of Aciclovir as directed in the potassium bromide disk method under Infrared Spectrophotometry <2.25>, and compare the spectrum with the Reference Spectrum or the spectrum of Aciclovir RS: both spectra exhibit similar intensities of absorption at the same wave numbers.

Purity (1) Clarity and color of solution—Dissolve 0.5 g of Aciclovir in 20 mL of dilute sodium hydroxide TS: the solution is clear and is not more colored than the following

control solution.

Control solution: To 2.5 mL of Matching Fluid F add diluted dilute hydrochloric acid (1 in 10) to make 100 mL.

(2) Heavy metals <1.07>—Proceed with 1.0 g of Aciclovir according to Method 2, and perform the test. Prepare the control solution with 1.0 mL of Standard Lead Solution (not more than 10 ppm).

(3) Related substances—Use the sample solution obtained in the Assay as the sample solution. Separately, weigh accurately about 25 mg of guanine, dissolve in 50 mL of dilute sodium hydroxide TS, and add the mobile phase to make exactly 100 mL. Pipet 2 mL of this solution, add the mobile phase to make exactly 100 mL, and use this solution as the standard solution. Perform the test with exactly 10 μ L each of the sample solution and standard solution as directed under Liquid Chromatography <2.01> according to the following conditions. Determine the peak areas of guanine, A_T and A_S , and calculate the amount of guanine by the following equation: it is not more than 0.7%. Determine each peak area from the sample solution by the automatic integration method, and calculate the amount of each related substance other than aciclovir and guanine by the area percentage method: it is not more than 0.2%. Furthermore, the sum of the amount of guanine calculated above and the amounts of related substances determined by the area percentage method is not more than 1.5%.

$$\text{Amount (\%)} \text{ of guanine} = M_S/M_T \times A_T/A_S \times 2/5$$

M_S : Amount (mg) of guanine taken

M_T : Amount (mg) of Aciclovir taken

Operating conditions—

Detector, column, column temperature, mobile phase, and flow rate: Proceed as directed in the operating conditions in the Assay.

Time span of measurement: About 8 times as long as the retention time of aciclovir, beginning after the solvent peak.

System suitability—

System performance: Proceed as directed in the system suitability in the Assay.

Test for required detectability: To 1 mL of the sample solution add the mobile phase to make 100 mL, and use this solution as the solution for system suitability test. Pipet 1 mL of the solution for system suitability test, and add the mobile phase to make exactly 10 mL. Confirm that the peak area of aciclovir obtained with 10 μ L of this solution is equivalent to 7 to 13% of that with 10 μ L of the solution for system suitability test.

System repeatability: When the test is repeated 6 times with 10 μ L of the standard solution under the above operating conditions, the relative standard deviation of the peak area of guanine is not more than 2.0%.

Water <2.48> Not more than 6.0% (50 mg, coulometric titration).

Residue on ignition <2.44> Not more than 0.1% (1 g).

Assay Weigh accurately about 20 mg each of Aciclovir and Aciclovir RS (separately determine the water <2.48> in the same manner as Aciclovir), dissolve each in 1 mL of dilute sodium hydroxide TS, add the mobile phase to make exactly 20 mL each, and use these solutions as the sample solution and the standard solution, respectively. Perform the test with exactly 10 μ L each of the sample solution and standard solution as directed under Liquid Chromatography <2.01> according to the following conditions, and determine the peak areas, A_T and A_S , of aciclovir in each solution.

$$\text{Amount (mg) of aciclovir (C}_8\text{H}_{11}\text{N}_5\text{O}_3) = M_S \times A_T/A_S$$

M_S : Amount (mg) of Aciclovir RS taken, calculated on the anhydrous basis

Operating conditions—

Detector: An ultraviolet absorption photometer (wavelength: 254 nm).

Column: A stainless steel column 4.6 mm in inside diameter and 10 cm in length, packed with octadecylsilanized silica gel for liquid chromatography (3 μ m in particle diameter).

Column temperature: A constant temperature of about 20°C.

Mobile phase: Dissolve 1.0 g of sodium 1-decanesulfonate and 6.0 g of sodium dihydrogen phosphate dihydrate in 1000 mL of water, and adjust the pH to 3.0 with phosphoric acid. To this solution add 40 mL of acetonitrile.

Flow rate: Adjust so that the retention time of aciclovir is about 3 minutes.

System suitability—

System performance: Dissolve 0.1 g of Aciclovir in 5 mL of dilute sodium hydroxide TS, add 2 mL of a solution of guanine in dilute sodium hydroxide TS (1 in 4000), and add the mobile phase to make 100 mL. When the procedure is run with 10 μ L of this solution under the above operating conditions, aciclovir and guanine are eluted in this order with the resolution between these peaks being not less than 17.

System repeatability: When the test is repeated 6 times with 10 μ L of the standard solution under the above operating conditions, the relative standard deviation of the peak area of aciclovir is not more than 1.0%.

Containers and storage Containers—Well-closed containers.

Aciclovir Granules

アシクロビル顆粒

Aciclovir Granules contain not less than 93.0% and not more than 107.0% of the labeled amount of aciclovir (C₈H₁₁N₅O₃; 225.20).

Method of preparation Prepare as directed under Granules, with Aciclovir.

Identification Determine the absorption spectrum of the sample solution obtained in the Assay as directed under Ultraviolet-visible Spectrophotometry <2.24>: it exhibits a maximum between 254 nm and 258 nm.

Uniformity of dosage units <6.02> Perform the test according to the following method: Aciclovir Granules in single-dose packages meet the requirement of the Content uniformity test.

To the total amount of the content of 1 package of Aciclovir Granules, add 100 mL of dilute sodium hydroxide TS, sonicate with occasional shaking, and add dilute sodium hydroxide TS to make exactly 200 mL. Filter this solution, discard the first 20 mL of the filtrate, pipet V mL of the subsequent filtrate, add dilute sodium hydroxide TS to make exactly V' mL so that each mL contains about 1 mg of aciclovir (C₈H₁₁N₅O₃). Pipet 15 mL of this solution, add 50 mL of water and 5.8 mL of 2 mol/L hydrochloric acid TS, add water to make exactly 100 mL. Pipet 5 mL of this solution, add 0.1 mol/L hydrochloric acid TS to make exactly 100 mL, and use this solution as the sample solution. Then,

proceed as directed in the Assay.

$$\begin{aligned} & \text{Amount (mg) of acyclovir (C}_8\text{H}_{11}\text{N}_5\text{O}_3\text{)} \\ & = M_S \times A_T/A_S \times V'/V \times 8 \end{aligned}$$

M_S : Amount (mg) of Aciclovir RS taken, calculated on the anhydrous basis

Dissolution <6.10> When the test is performed at 50 revolutions per minute according to the Paddle method, using 900 mL of water as the dissolution medium, the dissolution rate in 30 minutes of Aciclovir Granules is not less than 85%.

Start the test with an accurately weighed amount of Aciclovir Granules, equivalent to about 0.4 g of aciclovir (C₈H₁₁N₅O₃), withdraw not less than 20 mL of the medium at the specified minute after starting the test, and filter through a membrane filter with a pore size not exceeding 0.45 μm. Discard not less than 10 mL of the first filtrate, pipet 2 mL of the subsequent filtrate, add water to make exactly 100 mL, and use this solution as the sample solution. Separately, weigh accurately about 22 mg of Aciclovir RS (separately determine the water <2.48> in the same manner as Aciclovir), and dissolve in water to make exactly 100 mL. Pipet 4 mL of this solution, add water to make exactly 100 mL, and use this solution as the standard solution. Determine the absorbances, A_T and A_S , at 252 nm of the sample solution and standard solution as directed under Ultraviolet-visible Spectrophotometry <2.24>.

$$\begin{aligned} & \text{Dissolution rate (\% with respect to the labeled amount} \\ & \text{of aciclovir (C}_8\text{H}_{11}\text{N}_5\text{O}_3\text{)} \\ & = M_S/M_T \times A_T/A_S \times 1/C \times 1800 \end{aligned}$$

M_S : Amount (mg) of aciclovir RS taken, calculated on the anhydrous basis

M_T : Amount (g) of Aciclovir Granules taken

C : Labeled amount (mg) of aciclovir (C₈H₁₁N₅O₃) in 1 g

Assay Powder Aciclovir Granules, and weigh accurately a portion of the powder, equivalent to about 0.1 g of aciclovir (C₈H₁₁N₅O₃), add 60 mL of dilute sodium hydroxide TS, sonicate for 15 minutes, then add dilute sodium hydroxide TS to make exactly 100 mL, and filter. Discard the first 20 mL of filtrate, pipet 15 mL of the subsequent filtrate, add 50 mL of water and 5.8 mL of 2 mol/L hydrochloric acid TS, and add water to make exactly 100 mL. Pipet 5 mL of this solution, add 0.1 mol/L hydrochloric acid TS to make exactly 100 mL, and use this solution as the sample solution. Separately, weigh accurately about 25 mg of Aciclovir RS (separately determine the water <2.48> in the same manner as Aciclovir), and dissolve in dilute sodium hydroxide TS to make exactly 25 mL. Pipet 15 mL of this solution, add 50 mL of water and 5.8 mL of 2 mol/L hydrochloric acid TS, add water to make exactly 100 mL. Pipet 5 mL of this solution, add 0.1 mol/L hydrochloric acid TS to make exactly 100 mL, and use this solution as the standard solution. Determine the absorbances, A_T and A_S , at 255 nm of the sample solution and standard solution as directed under Ultraviolet-visible Spectrophotometry <2.24>, using 0.1 mol/L hydrochloric acid TS as the blank.

$$\begin{aligned} & \text{Amount (mg) of acyclovir (C}_8\text{H}_{11}\text{N}_5\text{O}_3\text{)} \\ & = M_S \times A_T/A_S \times 4 \end{aligned}$$

M_S : Amount (mg) of Aciclovir RS taken, calculated on the anhydrous basis

Containers and storage Containers—Tight containers.

Aciclovir Injection

アシクロビル注射液

Aciclovir Injection is an aqueous injection.

It contains not less than 95.0% and not more than 105.0% of the labeled amount of aciclovir (C₈H₁₁N₅O₃; 225.20).

Method of preparation Prepare as directed under Injections, with Aciclovir.

Description Aciclovir Injection occurs as a colorless or pale yellow, clear liquid.

Identification To a volume of Aciclovir Injection, equivalent to 25 mg of Aciclovir, add 0.5 mol/L hydrochloric acid TS to make 100 mL. To 2 mL of this solution add 0.5 mol/L hydrochloric acid TS to make 50 mL. Determine the absorption spectrum of this solution as directed under Ultraviolet-visible Spectrophotometry <2.24>: it exhibits a maximum between 254 nm and 258 nm.

Bacterial endotoxins <4.01> Less than 0.5 EU/mg.

Extractable volume <6.05> It meets the requirement.

Foreign insoluble matter <6.06> Perform the test according to Method 1: it meets the requirement.

Insoluble particulate matter <6.07> It meets the requirement.

Sterility <4.06> Perform the test according to the Membrane filtration method: it meets the requirement.

Assay To an exact volume of Aciclovir Injection, equivalent to about 25 mg of aciclovir (C₈H₁₁N₅O₃), add 0.1 mol/L hydrochloric acid TS to make exactly 100 mL. Pipet 2 mL of this solution, add exactly 5 mL of the internal standard solution, then add 0.1 mol/L hydrochloric acid TS to make 50 mL, and use this solution as the sample solution. Separately, weigh accurately about 25 mg of Aciclovir RS (separately determine the water <2.48> in the same manner as Aciclovir), and dissolve in 0.1 mol/L hydrochloric acid TS to make exactly 100 mL. Pipet 2 mL of this solution, add exactly 5 mL of the internal standard solution, then add 0.1 mol/L hydrochloric acid TS to make 50 mL, and use this solution as the standard solution. Perform the test with 20 μL each of the sample solution and standard solution as directed under Liquid Chromatography <2.01> according to the following conditions, and calculate the ratios, Q_T and Q_S , of the peak area of aciclovir to that of the internal standard.

$$\begin{aligned} & \text{Amount (mg) of aciclovir (C}_8\text{H}_{11}\text{N}_5\text{O}_3\text{)} \\ & = M_S \times Q_T/Q_S \end{aligned}$$

M_S : Amount (mg) of Aciclovir RS taken, calculated on the anhydrous basis

Internal standard solution—A solution of nicotinic acid in 0.1 mol/L hydrochloric acid TS (3 in 20,000).

Operating conditions—

Detector: An ultraviolet absorption photometer (wavelength: 254 nm).

Column: A stainless steel column 4.6 mm in inside diameter and 15 cm in length, packed with octadecylsilanized silica gel for liquid chromatography (5 μm in particle diameter).

Column temperature: A constant temperature of about 25°C.

Mobile phase: To 1.45 g of phosphoric acid and 25 mL of

dilute acetic acid add water to make 900 mL. Adjust this solution to pH 2.5 with 1 mol/L sodium hydroxide TS, and add water to make 1000 mL. To 950 mL of this solution add 50 mL of methanol.

Flow rate: Adjust so that the retention time of aciclovir is about 7 minutes.

System suitability—

System performance: When the procedure is run with 20 μ L of the standard solution under the above operating conditions, the internal standard and aciclovir are eluted in this order with the resolution between these peaks being not less than 3.

System repeatability: When the test is repeated 6 times with 20 μ L of the standard solution under the above operating conditions, the relative standard deviation of the ratio of the peak area of aciclovir to that of the internal standard is not more than 1.0%.

Containers and storage Containers—Hermetic containers.

Aciclovir for Injection

注射用アシクロビル

Aciclovir for Injection is a preparation for injection which is dissolved before use.

It contains not less than 95.0% and not more than 105.0% of the labeled amount of aciclovir ($C_8H_{11}N_5O_3$; 225.20).

Method of preparation Prepare as directed under Injections, with Aciclovir.

Description Aciclovir for Injection occurs as white to pale yellow-white, light masses or powder.

Identification Determine the absorption spectrum of the sample solution obtained in the Assay as directed under Ultraviolet-visible Spectrophotometry <2.24>: it exhibits a maximum between 254 nm and 258 nm.

pH Being specified separately when the drug is granted approval based on the Law.

Purity Clarity and color of solution—Dissolve an amount of Aciclovir for Injection, equivalent to 0.25 g of Aciclovir, in 10 mL of water: the solution is clear and is not more colored than the following control solution.

Control solution: To 2.5 mL of Matching Fluid F add diluted dilute hydrochloric acid (1 in 10) to make 100 mL.

Water <2.48> Not more than 7.5% (0.1 g, volumetric titration, direct titration).

Bacterial endotoxins <4.01> Less than 0.25 EU/mg.

Uniformity of dosage units <6.02> It meets the requirement of the Mass variation test.

Foreign insoluble matter <6.06> Perform the test according to Method 2: it meets the requirement.

Insoluble particulate matter <6.07> It meets the requirement.

Sterility <4.06> Perform the test according to the Membrane filtration method: it meets the requirement.

Assay Weigh accurately the mass of the contents of not less than 10 Aciclovir for Injection. Weigh accurately an amount of the contents, equivalent to about 0.1 g of aciclovir ($C_8H_{11}N_5O_3$), and dissolve in dilute sodium hy-

droxide TS to make exactly 100 mL. Pipet 15 mL of this solution, add 70 mL of water and 5 mL of 2 mol/L hydrochloric acid TS, then add water to make exactly 100 mL. Pipet 5 mL of this solution, add 0.1 mol/L hydrochloric acid TS to make exactly 100 mL, and use this solution as the sample solution. Separately, weigh accurately about 20 mg of Aciclovir RS (separately determine the water <2.48> in the same manner as Aciclovir), and dissolve in dilute sodium hydroxide TS to make exactly 20 mL. Pipet 15 mL of this solution, add 70 mL of water and 5 mL of 2 mol/L hydrochloric acid TS, then add water to make exactly 100 mL. Pipet 5 mL of this solution, add 0.1 mol/L hydrochloric acid TS to make exactly 100 mL, and use this solution as the standard solution. Determine the absorbances, A_T and A_S , at 255 nm of the sample solution and standard solution as directed under Ultraviolet-visible Spectrophotometry <2.24>, using 0.1 mol/L hydrochloric acid TS as the blank.

$$\begin{aligned} & \text{Amount (mg) of aciclovir (C}_8\text{H}_{11}\text{N}_5\text{O}_3\text{)} \\ & = M_S \times A_T / A_S \times 5 \end{aligned}$$

M_S : Amount (mg) of Aciclovir RS taken, calculated on the anhydrous basis

Containers and storage Containers—Hermetic containers.

Aciclovir Ointment

アシクロビル軟膏

Aciclovir Ointment contains not less than 95.0% and not more than 105.0% of the labeled amount of aciclovir ($C_8H_{11}N_5O_3$; 225.20).

Method of preparation Prepare as directed under Ointments, with Aciclovir.

Identification Determine the absorption spectrum of the sample solution obtained in the Assay as directed under Ultraviolet-visible Spectrophotometry <2.24>: it exhibits a maximum between 254 nm and 258 nm.

Assay Weigh accurately an amount of Aciclovir Ointment, equivalent to about 10 mg of aciclovir ($C_8H_{11}N_5O_3$), add 25 mL of dilute sodium hydroxide TS, warm if necessary, and dissolve by shaking. After cooling, add water to make exactly 100 mL. Pipet 15 mL of this solution, add 0.1 mol/L hydrochloric acid TS to make exactly 200 mL, and use this solution as the sample solution. Separately, weigh accurately about 20 mg of Aciclovir RS (separately, determine the water <2.48> in the same manner as Aciclovir), and dissolve in dilute sodium hydroxide TS to make exactly 20 mL. Pipet 10 mL of this solution, and add 15 mL of dilute sodium hydroxide TS and water to make exactly 100 mL. Pipet 15 mL of this solution, add 0.1 mol/L hydrochloric acid TS to make exactly 200 mL, and use this solution as the standard solution. Determine the absorbances, A_T and A_S , at 255 nm of the sample solution and standard solution as directed under Ultraviolet-visible Spectrophotometry <2.24>, using 0.1 mol/L hydrochloric acid TS as the blank.

$$\begin{aligned} & \text{Amount (mg) of aciclovir (C}_8\text{H}_{11}\text{N}_5\text{O}_3\text{)} \\ & = M_S \times A_T / A_S \times 1/2 \end{aligned}$$

M_S : Amount (mg) of Aciclovir RS taken, calculated on the anhydrous basis

Containers and storage Containers—Tight containers.

Aciclovir Ophthalmic Ointment

アシクロビル眼軟膏

Aciclovir Ophthalmic Ointment contains not less than 90.0% and not more than 110.0% of the labeled amount of aciclovir ($C_8H_{11}N_5O_3$; 225.20).

Method of preparation Prepare as directed under Ophthalmic Ointments, with Aciclovir.

Identification Determine the absorption spectrum of the sample solution obtained in the Assay as directed under Ultraviolet-visible Spectrophotometry <2.24>: it exhibits a maximum between 254 nm and 258 nm.

Metal Particles <6.01> It meets the requirement.

Sterility <4.06> Perform the test according to the Membrane filtration method: it meets the requirement.

Particle diameter Being specified separately when the drug is granted approval based on the Law.

Assay Weigh accurately a portion of Aciclovir Ophthalmic Ointment, equivalent to about 15 mg of aciclovir ($C_8H_{11}N_5O_3$), add exactly 20 mL of hexane and exactly 20 mL of dilute sodium hydroxide TS, and shake vigorously. Centrifuge this mixture, discard the upper layer, pipet 1 mL of the lower layer, add 70 mL of water and 5 mL of 2 mol/L hydrochloric acid TS, then add water to make exactly 100 mL, and use this solution as the sample solution. Separately, weigh accurately about 15 mg of Aciclovir RS (separately determine the water <2.48> in the same manner as Aciclovir), and dissolve in dilute sodium hydroxide TS to make exactly 20 mL. Pipet 1 mL of this solution, add 70 mL of water and 5 mL of 2 mol/L hydrochloric acid TS, then add water to make exactly 100 mL, and use this solution as the standard solution. Determine the absorbances, A_T and A_S , at 255 nm of the sample solution and standard solution as directed under Ultraviolet-visible Spectrophotometry <2.24>, using water as the blank.

$$\text{Amount (mg) of acyclovir } (C_8H_{11}N_5O_3) = M_S \times A_T/A_S$$

M_S : Amount (mg) of Aciclovir RS taken, calculated on the anhydrous basis

Containers and storage Containers—Tight containers.

Aciclovir Syrup

アシクロビルシロップ

Aciclovir Syrup is a suspension syrup.

It contains not less than 93.0% and not more than 107.0% of the labeled amount of aciclovir ($C_8H_{11}N_5O_3$; 225.20).

Method of preparation Prepare as directed under Syrups, with Aciclovir.

Identification To a volume of thoroughly shaken Aciclovir Syrup, equivalent to 80 mg of Aciclovir, add 0.1 mol/L hydrochloric acid TS to make 100 mL. Centrifuge this solution, to 1 mL of the supernatant liquid add 0.1 mol/L hydrochloric acid TS to make 100 mL. Determine the absorption spectrum of this solution as directed under Ultraviolet-visible Spectrophotometry <2.24>: it exhibits a

maximum between 254 nm and 258 nm.

Dissolution <6.10> When the test is performed at 50 revolutions per minute according to the Paddle method, using 900 mL of water as the dissolution medium, the dissolution rate in 15 minutes of Aciclovir Syrup is not less than 85%.

Start the test with an exact volume of thoroughly shaken Aciclovir Syrup, equivalent to about 0.4 g of aciclovir ($C_8H_{11}N_5O_3$), withdraw not less than 20 mL of the medium at the specified minute after starting the test, and centrifuge. Pipet 2 mL of the supernatant liquid, add water to make exactly 100 mL, and use this solution as the sample solution. Separately, weigh accurately about 22 mg of Aciclovir RS (separately determine the water <2.48> in the same manner as Aciclovir), and dissolve in water to make exactly 100 mL. Pipet 4 mL of this solution, add water to make exactly 100 mL, and use this solution as the standard solution. Determine the absorbances, A_T and A_S , at 252 nm of the sample solution and standard solution as directed under Ultraviolet-visible Spectrophotometry <2.24>.

Dissolution rate (%) with respect to the labeled amount of aciclovir ($C_8H_{11}N_5O_3$)

$$= M_S/V_T \times A_T/A_S \times 1/C \times 1800$$

M_S : Amount (mg) of Aciclovir RS taken, calculated on the anhydrous basis

V_T : Amount (mL) of Aciclovir Syrup taken

C : Labeled amount (mg) of aciclovir ($C_8H_{11}N_5O_3$) in 1 mL

Assay Shake thoroughly Aciclovir Syrup. To an exact volume of the syrup, equivalent to about 80 mg of aciclovir ($C_8H_{11}N_5O_3$), add 0.1 mol/L hydrochloric acid TS to make exactly 100 mL. Centrifuge this solution, pipet 2 mL of the supernatant liquid, add exactly 5 mL of the internal standard solution, then add 0.1 mol/L hydrochloric acid TS to make 50 mL, and use this solution as the sample solution. Separately, weigh accurately about 40 mg of Aciclovir RS (separately determine the water <2.48> in the same manner as Aciclovir), and dissolve in 0.1 mol/L hydrochloric acid TS to make exactly 50 mL. Pipet 2 mL of this solution, add exactly 5 mL of the internal standard solution, then add 0.1 mol/L hydrochloric acid TS to make 50 mL, and use this solution as the standard solution. Perform the test with 20 μ L each of the sample solution and standard solution as directed under Liquid Chromatography <2.01> according to the following conditions, and calculate the ratios, Q_T and Q_S , of the peak area of aciclovir to that of the internal standard.

Amount (mg) of aciclovir ($C_8H_{11}N_5O_3$)

$$= M_S \times Q_T/Q_S \times 2$$

M_S : Amount (mg) of Aciclovir RS taken, calculated on the anhydrous basis

Internal standard solution—A solution of nicotinic acid in 0.1 mol/L hydrochloric acid TS (1 in 2000).

Operating conditions—

Detector: An ultraviolet absorption photometer (wavelength: 254 nm).

Column: A stainless steel column 4.6 mm in inside diameter and 15 cm in length, packed with octadecylsilanized silica gel for liquid chromatography (5 μ m in particle diameter).

Column temperature: A constant temperature of about 25°C.

Mobile phase: To 1.45 g of phosphoric acid and 25 mL of dilute acetic acid add water to make 900 mL. Adjust this solution to pH 2.5 with 1 mol/L sodium hydroxide TS, and add water to make 1000 mL. To 950 mL of this solution add 50 mL of methanol.

Flow rate: Adjust so that the retention time of aciclovir is about 7 minutes.

System suitability—

System performance: When the procedure is run with 20 μL of the standard solution under the above operating conditions, the internal standard and aciclovir are eluted in this order with the resolution between these peaks being not less than 3.

System repeatability: When the test is repeated 6 times with 20 μL of the standard solution under the above operating conditions, the relative standard deviation of the ratio of the peak area of aciclovir to that of the internal standard is not more than 1.0%.

Containers and storage Containers—Tight containers.

Aciclovir for Syrup

シロップ用アシクロビル

Aciclovir for Syrup is a preparation for syrup, which is suspended before use.

It contains not less than 95.0% and not more than 105.0% of the labeled amount of aciclovir ($\text{C}_8\text{H}_{11}\text{N}_5\text{O}_3$; 225.20).

Method of preparation Prepare as directed under Preparations for Syrup, with Aciclovir.

Identification Dissolve an amount of Aciclovir for Syrup, equivalent to 12 mg of Aciclovir, in 0.1 mol/L hydrochloric acid TS to make 50 mL. To 2 mL of this solution add 0.1 mol/L hydrochloric acid TS to make 50 mL, and determine the absorption spectrum of this solution as directed under Ultraviolet-visible Spectrophotometry <2.24>: it exhibits a maximum between 254 nm and 258 nm.

Uniformity of dosage units <6.02> Perform the test according to the following method: Aciclovir for Syrup in single-dose packages meets the requirement of the Content uniformity test.

To the total content of 1 package of Aciclovir for Syrup add 2V/25 mL of diluted sodium hydroxide TS (1 in 10), and sonicate to disintegrate, add water to make exactly V mL so that each mL contains about 0.8 mg of aciclovir ($\text{C}_8\text{H}_{11}\text{N}_5\text{O}_3$), and filter this solution through a membrane filter with a pore size not exceeding 0.45 μm . Discard the first 2 mL of the filtrate, pipet 5 mL of the subsequent filtrate, add exactly 5 mL of the internal standard solution, then add the mobile phase to make 50 mL, and use this solution as the sample solution. Then, proceed as directed in the Assay.

$$\begin{aligned} &\text{Amount (mg) of aciclovir (C}_8\text{H}_{11}\text{N}_5\text{O}_3\text{)} \\ &= M_S \times Q_T/Q_S \times V/10 \end{aligned}$$

M_S : Amount (mg) of Aciclovir RS taken, calculated on the anhydrous basis

Internal standard solution—A solution of parahydroxybenzoic acid in the mobile phase (1 in 1250).

Dissolution <6.10> When the test is performed at 50 revolutions per minute according to the Paddle method, using 900 mL of water as the dissolution medium, the dissolution rate in 45 minutes of Aciclovir for Syrup is not less than 85%.

Start the test with an accurately weighed amount of Aciclovir for Syrup, equivalent to about 0.2 g of aciclovir ($\text{C}_8\text{H}_{11}\text{N}_5\text{O}_3$), withdraw not less than 5 mL of the medium at

the specified minute after starting the test, and filter through a membrane filter with a pore size not exceeding 0.45 μm . Discard not less than 2 mL of the first filtrate, pipet 2 mL of the subsequent filtrate, add water to make exactly 50 mL, and use this solution as the sample solution. Separately, weigh accurately about 11 mg of Aciclovir RS (separately determine the water <2.48> in the same manner as Aciclovir), and dissolve in water to make exactly 50 mL. Pipet 2 mL of this solution, add water to make exactly 50 mL, and use this solution as the standard solution. Determine the absorbances, A_T and A_S , at 254 nm of the sample solution and standard solution as directed under Ultraviolet-visible Spectrophotometry <2.24>.

$$\begin{aligned} &\text{Dissolution rate (\%)} \text{ with respect to the labeled amount} \\ &\text{of aciclovir (C}_8\text{H}_{11}\text{N}_5\text{O}_3\text{)} \\ &= M_S/M_T \times A_T/A_S \times 1/C \times 1800 \end{aligned}$$

M_S : Amount (mg) of Aciclovir RS taken, calculated on the anhydrous basis

M_T : Amount (g) of Aciclovir for Syrup taken

C: Labeled amount (mg) of aciclovir ($\text{C}_8\text{H}_{11}\text{N}_5\text{O}_3$) in 1 g

Assay Weigh accurately an amount of Aciclovir for Syrup, previously powdered if necessary, equivalent to about 0.2 g of aciclovir ($\text{C}_8\text{H}_{11}\text{N}_5\text{O}_3$), add 20 mL of diluted sodium hydroxide TS (1 in 10), sonicate to disintegrate, then add water to make exactly 200 mL, and filter this solution through a membrane filter with a pore size not exceeding 0.45 μm . Discard the first 2 mL of the filtrate, pipet 5 mL of the subsequent filtrate, add exactly 5 mL of the internal standard solution, then add the mobile phase to make 50 mL, and use this solution as the sample solution. Separately, weigh accurately about 10 mg of Aciclovir RS (separately determine the water <2.48> in the same manner as Aciclovir), add exactly 10 mL of the internal standard solution, then add the mobile phase to make 100 mL, and use this solution as the standard solution. Perform the test with 20 μL each of the sample solution and standard solution as directed under Liquid Chromatography <2.01> according to the following conditions, and calculate the ratios, Q_T and Q_S , of the peak area of aciclovir to that of the internal standard.

$$\begin{aligned} &\text{Amount (mg) of aciclovir (C}_8\text{H}_{11}\text{N}_5\text{O}_3\text{)} \\ &= M_S \times Q_T/Q_S \times 20 \end{aligned}$$

M_S : Amount (mg) of Aciclovir RS taken, calculated on the anhydrous basis

Internal standard solution—A solution of parahydroxybenzoic acid in the mobile phase (1 in 1250).

Operating conditions—

Detector: An ultraviolet absorption photometer (wavelength: 254 nm).

Column: A stainless steel column 4.6 mm in inside diameter and 25 cm in length, packed with octadecylsilanized silica gel for liquid chromatography (5 μm in particle diameter).

Column temperature: A constant temperature of about 40°C.

Mobile phase: Dissolve 7.8 g of sodium dihydrogen phosphate dihydrate and 0.85 g of sodium 1-octanesulfonate in 900 mL of water, adjust to pH 3.0 with phosphoric acid, add water to make 950 mL, and add 50 mL of acetonitrile.

Flow rate: Adjust so that the retention time of aciclovir is about 5 minutes.

System suitability—

System performance: When the procedure is run with 20 μL of the standard solution under the above operating conditions, aciclovir and the internal standard are eluted in this order with the resolution between these peaks being not less

than 20.

System repeatability: When the test is repeated 6 times with 20 μL of the standard solution under the above operating conditions, the relative standard deviation of the ratio of the peak area of aciclovir to that of the internal standard is not more than 1.0%.

Containers and storage Containers—Tight containers.

Aciclovir Tablets

アシクロビル錠

Aciclovir Tablets contain not less than 95.0% and not more than 105.0% of the labeled amount of aciclovir ($\text{C}_8\text{H}_{11}\text{N}_5\text{O}_3$: 225.20).

Method of preparation Prepare as directed under Tablets, with Aciclovir.

Identification Determine the absorption spectrum of the sample solution obtained in the Assay as directed under Ultraviolet-visible Spectrophotometry <2.24>: it exhibits a maximum between 254 nm and 258 nm.

Uniformity of dosage units <6.02> It meets the requirement of the Mass variation test.

Dissolution <6.10> When the test is performed at 50 revolutions per minute according to the Paddle method, using 900 mL of water as the dissolution medium, the dissolution rate in 30 minutes of Aciclovir Tablets is not less than 80%.

Start the test with 1 tablet of Aciclovir Tablets, withdraw not less than 20 mL of the medium at the specified minute after starting the test, and filter through a membrane filter with a pore size not exceeding 0.45 μm . Discard not less than 10 mL of the first filtrate, pipet V mL of the subsequent filtrate, add water to make exactly V' mL so that each mL contains about 8.9 μg of aciclovir ($\text{C}_8\text{H}_{11}\text{N}_5\text{O}_3$), and use this solution as the sample solution. Separately, weigh accurately about 22 mg of aciclovir RS (separately determine the water <2.48> in the same manner as Aciclovir), and dissolve in water to make exactly 100 mL. Pipet 4 mL of this solution, add water to make exactly 100 mL, and use this solution as the standard solution. Determine the absorbances, A_T and A_S , at 252 nm of the sample solution and standard solution as directed under Ultraviolet-visible Spectrophotometry <2.24>.

Dissolution rate (%) with respect to the labeled amount of aciclovir ($\text{C}_8\text{H}_{11}\text{N}_5\text{O}_3$)

$$= M_S \times A_T / A_S \times V' / V \times 1 / C \times 36$$

M_S : Amount (mg) of Aciclovir RS taken, calculated on the anhydrous basis

C : Labeled amount (mg) of aciclovir ($\text{C}_8\text{H}_{11}\text{N}_5\text{O}_3$) in 1 tablet

Assay Weigh accurately the mass of not less than 20 Aciclovir Tablets, and powder. Weigh accurately a portion of the powder, equivalent to about 0.1 g of aciclovir ($\text{C}_8\text{H}_{11}\text{N}_5\text{O}_3$), add 60 mL of dilute sodium hydroxide TS, and sonicate for 15 minutes, then add dilute sodium hydroxide TS to make exactly 100 mL, and filter. Discard the first 20 mL of filtrate, pipet 15 mL of the subsequent filtrate, add 50 mL of water and 5.8 mL of 2 mol/L hydrochloric acid TS, and add water to make exactly 100 mL. Pipet 5 mL of this solution, add 0.1 mol/L hydrochloric acid TS to make exactly 100 mL, and use this solution as the sample solution.

Separately, weigh accurately about 25 mg of Aciclovir RS (separately determine the water <2.48> in the same manner as Aciclovir), and dissolve in dilute sodium hydroxide TS to make exactly 25 mL. Pipet 15 mL of this solution, add 50 mL of water and 5.8 mL of 2 mol/L hydrochloric acid TS, add water to make exactly 100 mL. Pipet 5 mL of this solution, add 0.1 mol/L hydrochloric acid TS to make exactly 100 mL, and use this solution as the standard solution. Determine the absorbances, A_T and A_S , at 255 nm of the sample solution and standard solution as directed under Ultraviolet-visible Spectrophotometry <2.24>, using 0.1 mol/L hydrochloric acid TS as the blank.

$$\begin{aligned} &\text{Amount (mg) of aciclovir (C}_8\text{H}_{11}\text{N}_5\text{O}_3) \\ &= M_S \times A_T / A_S \times 4 \end{aligned}$$

M_S : Amount (mg) of Aciclovir RS taken, calculated on the anhydrous basis

Containers and storage Containers—Well-closed containers.

Aclarubicin Hydrochloride

アクラルピシン塩酸塩

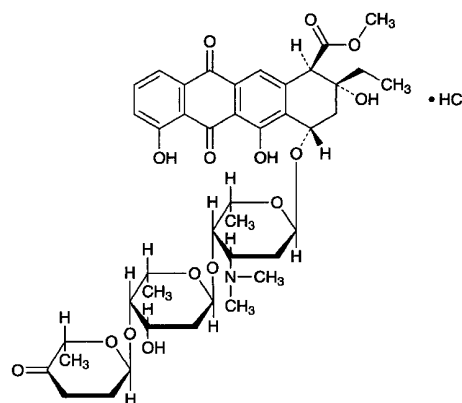

$\text{C}_{42}\text{H}_{53}\text{NO}_{15} \cdot \text{HCl}$: 848.33

Methyl (1*R*,2*R*,4*S*)-4-[2,6-dideoxy-4-*O*-(2*R*,6*S*)-6-methyl-5-oxo-3,4,5,6-tetrahydro-2*H*-pyran-2-yl]- α -*L*-lyxo-hexopyranosyl-(1 \rightarrow 4)-2,3,6-trideoxy-3-dimethylamino- α -*L*-lyxo-hexopyranosyloxy}-2-ethyl-2,5,7-trihydroxy-6,11-dioxo-1,2,3,4-tetrahydrotetracene-1-carboxylate monohydrochloride
[75443-99-1]

Aclarubicin Hydrochloride is the hydrochloride of an anthracycline substance having antitumor activity produced by the growth of *Streptomyces galilaeus*.

It contains not less than 920 μg (potency) and not more than 975 μg (potency) per mg, calculated on the anhydrous basis. The potency of Aclarubicin Hydrochloride is expressed as mass (potency) of aclarubicin ($\text{C}_{42}\text{H}_{53}\text{NO}_{15}$: 811.87).

Description Aclarubicin Hydrochloride occurs as a yellow to pale orange-yellow powder.

It is very soluble in chloroform and in methanol, freely soluble in water, and slightly soluble in ethanol (95).

Identification (1) Determine the absorption spectrum of a solution of Aclarubicin Hydrochloride in diluted methanol (4 in 5) (3 in 100,000) as directed under Ultraviolet-visible Spectrophotometry <2.24>, and compare the spectrum with the Reference Spectrum: both spectra exhibit similar intensi-

ties of absorption at the same wavelengths.

(2) Determine the infrared absorption spectrum of Aclarubicin Hydrochloride as directed in the potassium bromide disk method under Infrared Spectrophotometry <2.25>, and compare the spectrum with the Reference Spectrum: both spectra exhibit similar intensities of absorption at the same wave numbers.

(3) A solution of Aclarubicin Hydrochloride in methanol (1 in 200) responds to Qualitative Tests <1.09> (2) for chloride.

Optical rotation <2.49> $[\alpha]_D^{20}$: $-146 - -162^\circ$ (50 mg calculated on the anhydrous basis, water, 10 mL, 100 mm).

pH <2.54> The pH of a solution obtained by dissolving 0.05 g of Aclarubicin Hydrochloride in 10 mL of water is between 5.5 and 6.5.

Purity (1) Clarity and color of solution—Dissolve 0.10 g of Aclarubicin Hydrochloride in 10 mL of water: the solution is clear and yellow to pale orange-yellow.

(2) Heavy metals <1.07>—Proceed with 1.0 g of Aclarubicin Hydrochloride according to Method 2, and perform the test. Prepare the control solution with 2.0 mL of Standard Lead Solution (not more than 20 ppm).

(3) Related substances—Dissolve 10 mg of Aclarubicin Hydrochloride in 10 mL of the mobile phase, and use this solution as the sample solution. Perform the test with 20 μ L of the sample solution as directed under Liquid Chromatography <2.01> according to the following conditions, and determine each peak area by the automatic integration method. Calculate the amount of the related substances by the area percentage method: the amount of aklavinone having the relative retention time of about 0.6 to aclarubicin is not more than 0.2%, aclacinomycin L1 having the relative retention time of about 0.75 is not more than 0.5%, 1-deoxytetracycline having the relative retention time of about 1.7 is not more than 1.5% and aclacinomycin S1 having the relative retention time of about 2.3 is not more than 0.5%, and the total amount of the peaks other than aclarubicin and the peaks mentioned above is not more than 1.0% of the peak area of aclarubicin.

Operating conditions—

Detector: A visible absorption photometer (wavelength: 436 nm).

Column: A stainless steel column 3.9 mm in inside diameter and 30 cm in length, packed with silica gel for liquid chromatography (10 μ m in particle diameter).

Column temperature: A constant temperature of about 25°C.

Mobile phase: A mixture of chloroform, methanol, acetic acid (100), water and triethylamine (6800:2000:1000:200:1).

Flow rate: Adjust so that the retention time of aclarubicin is about 5 minutes.

Time span of measurement: As long as about 4 times of the retention time of aclarubicin, beginning after the solvent peak.

System suitability—

Test for required detectability: To 1 mL of the sample solution, add the mobile phase to make 100 mL, and use this solution as the solution for system suitability test. Pipet 1 mL of the solution for system suitability test, and add the mobile phase to make exactly 10 mL. Confirm that the peak area of aclarubicin obtained with 20 μ L of this solution is equivalent to 7 to 13% of that with 20 μ L of the solution for system suitability test.

System performance: Dissolve 5 mg of Aclarubicin Hydrochloride in 10 mL of 0.1 mol/L hydrochloric acid TS,

and allow to stand for 60 minutes. To 1.0 mL of this solution add 1.0 mL of 0.2 mol/L sodium hydroxide TS, 1.0 mL of phosphate buffer solution (pH 8.0) and 1.0 mL of chloroform, shake vigorously, and take the chloroform layer. When the procedure is run with 20 μ L of the chloroform under the above operating conditions, aclarubicin and 1-deoxytetracycline are eluted in this order with the resolution between these peaks being not less than 3.0.

System repeatability: When the test is repeated 5 times with 20 μ L of the sample solution under the above operating conditions, the relative standard deviation of the peak area of aclarubicin is not more than 2.0%.

Water <2.48> Not more than 3.5% (0.1 g, volumetric titration, direct titration).

Residue on ignition <2.44> Not more than 0.1% (1 g).

Assay Weigh accurately an amount of Aclarubicin Hydrochloride, equivalent to about 20 mg (potency), and dissolve in diluted methanol (4 in 5) to make exactly 100 mL. Pipet 15 mL of this solution, add diluted methanol (4 in 5) to make exactly 100 mL, and use this solution as the sample solution. Separately, weigh accurately an amount of Aclarubicin RS, equivalent to about 20 mg (potency), add 0.6 mL of diluted hydrochloric acid (1 in 250) and diluted methanol (4 in 5) to make exactly 100 mL. Pipet 15 mL of this solution, add diluted methanol (4 in 5) to make exactly 100 mL, and use this solution as the standard solution. Perform the test with the sample solution and standard solution as directed under Ultraviolet-visible Spectrophotometry <2.24>, and determine the absorbances, A_T and A_S , at 433 nm.

$$\begin{aligned} \text{Amount } [\mu\text{g (potency)}] \text{ of aclarubicin (C}_{42}\text{H}_{53}\text{NO}_{15}) \\ = M_S \times A_T / A_S \times 1000 \end{aligned}$$

M_S : Amount [mg (potency)] of Aclarubicin RS taken

Containers and storage Containers—Tight containers.

Storage—Light-resistant and at 5°C or below.

Acrinol Hydrate

Ethacridine Lactate

アクリノール水和物

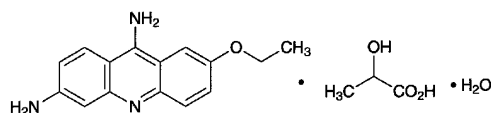

$\text{C}_{15}\text{H}_{15}\text{N}_3\text{O} \cdot \text{C}_3\text{H}_6\text{O}_3 \cdot \text{H}_2\text{O}$: 361.39

2-Ethoxy-6,9-diaminoacridine monolactate monohydrate [6402-23-9]

Acrinol Hydrate contains not less than 98.5% and not more than 101.0% of acrinol ($\text{C}_{15}\text{H}_{15}\text{N}_3\text{O} \cdot \text{C}_3\text{H}_6\text{O}_3$: 343.38), calculated on the anhydrous basis.

Description Acrinol Hydrate occurs as a yellow crystalline powder.

It is sparingly soluble in water, in methanol and in ethanol (99.5).

Melting point: about 245°C (with decomposition).

The pH of a solution of Acrinol Hydrate (1 in 100) is between 5.5 and 7.0.

Identification (1) Determine the absorption spectrum of a solution of Acrinol Hydrate (3 in 250,000) as directed under

Ultraviolet-visible Spectrophotometry <2.24>, and compare the spectrum with the Reference Spectrum: both spectra exhibit similar intensities of absorption at the same wavelengths.

(2) Determine the infrared absorption spectrum of Acrinol Hydrate as directed in the potassium bromide disk method under Infrared Spectrophotometry <2.25>, and compare the spectrum with the Reference Spectrum: both spectra exhibit similar intensities of absorption at the same wave numbers.

(3) To 5 mL of a solution of Acrinol Hydrate (1 in 100) add 5 mL of dilute sulfuric acid, shake well, allow to stand for about 10 minutes at room temperature, and filter: the filtrate responds to Qualitative Tests <1.09> for lactate.

Purity (1) Chloride <1.03>—Dissolve 1.0 g of Acrinol Hydrate in 80 mL of water by warming on a water bath, cool, and add 10 mL of sodium hydroxide TS and water to make 100 mL. Shake well, allow to stand for 30 minutes, filter, to 40 mL of the filtrate add 7 mL of dilute nitric acid and water to make 50 mL, and perform the test using this solution as the test solution. Prepare 50 mL of the control solution with 4 mL of sodium hydroxide TS, 7 mL of dilute nitric acid, 0.30 mL of 0.01 mol/L hydrochloric acid VS and sufficient water (not more than 0.026%).

(2) Heavy metals <1.07>—Proceed with 1.0 g of Acrinol Hydrate according to Method 2, and perform the test. Prepare the control solution with 2.0 mL of Standard Lead Solution (not more than 20 ppm).

(3) Volatile fatty acids—Dissolve 0.5 g of Acrinol Hydrate in a mixture of 20 mL of water and 5 mL of dilute sulfuric acid, shake well, filter, and heat the filtrate: no odor of volatile fatty acids is perceptible.

(4) Related substances—Dissolve 10 mg of Acrinol Hydrate in 25 mL of the mobile phase, and use this solution as the sample solution. Pipet 1 mL of the sample solution, add the mobile phase to make exactly 100 mL, and use this solution as the standard solution (1). Pipet 1 mL of the standard solution (1), add the mobile phase to make exactly 10 mL, and use this solution as the standard solution (2). Perform the test with exactly 10 μ L each of the sample solution and standard solutions (1) and (2) as directed under Liquid Chromatography <2.01> according to the following conditions, and determine each peak area by the automatic integration method: the area of the peak other than acrinol obtained from the sample solution is not larger than 3 times the peak area of acrinol from the standard solution (2), and the total area of the peaks other than acrinol from the sample solution is not larger than the peak area of acrinol from the standard solution (1).

Operating conditions—

Detector: An ultraviolet absorption photometer (wavelength: 268 nm).

Column: A stainless steel column 4.6 mm in inside diameter and 25 cm in length, packed with octadecylsilylated silica gel for liquid chromatography (5 μ m in particle diameter).

Column temperature: A constant temperature of about 25°C.

Mobile phase: Dissolve 7.8 g of sodium dihydrogen phosphate in 900 mL of water, adjust to pH 2.8 with phosphoric acid, and add water to make 1000 mL. To 700 mL of this solution add 300 mL of acetonitrile for liquid chromatography, and add 1.0 g of sodium 1-octanesulfonate to dissolve.

Flow rate: Adjust so that the retention time of acrinol is about 15 minutes.

Time span of measurement: About 3 times as long as the retention time of acrinol, beginning after the solvent peak.

System suitability—

Test for required detectability: Confirm that the peak area of acrinol obtained with 10 μ L of the standard solution (2) is equivalent to 7 to 13% of that with 10 μ L of the standard solution (1).

System performance: When the procedure is run with 10 μ L of the standard solution (1) under the above operating conditions, the number of theoretical plates and the symmetry factor of the peak of acrinol are not less than 5000 and not more than 2.0, respectively.

System repeatability: When the test is repeated 6 times with 10 μ L of the standard solution (1) under the above operating conditions, the relative standard deviation of the peak area of acrinol is not more than 1.5%.

Water <2.48> 4.5 – 5.5% (0.2 g, volumetric titration, direct titration)

Residue on ignition <2.44> Not more than 0.1% (1 g).

Assay Weigh accurately about 0.27 g of Acrinol Hydrate, dissolve in 5 mL of formic acid, add 60 mL of a mixture of acetic anhydride and acetic acid (100) (1:1), and titrate <2.50> immediately with 0.1 mol/L perchloric acid VS (potentiometric titration). Perform a blank determination in the same manner, and make any necessary correction.

Each mL of 0.1 mol/L perchloric acid VS
= 34.34 mg of C₁₅H₁₅N₃O₃·C₃H₆O₃

Containers and storage Containers—Tight containers.

Storage—Light-resistant.

Acrinol and Zinc Oxide Oil

アクリノール・チンク油

Acrinol and Zinc Oxide Oil contains not less than 44.6% and not more than 54.4% of zinc oxide (ZnO: 81.38).

Method of preparation

Acrinol Hydrate, very finely powdered	10 g
Zinc Oxide Oil	990 g
To make 1000 g	

Prepare by mixing the above ingredients. Acrinol Hydrate may be mixed after being dissolved in a little amount of warmed Purified Water or Purified Water in Containers. Instead of Zinc Oxide Oil adequate amounts of Zinc Oxide and vegetable oil may be used, and an adequate amount of Castor Oil or polysorbate 20 may be substituted for a part of the vegetable oil.

Description Acrinol and Zinc Oxide Oil is a yellow-white, slimy substance. Separation of a part of its ingredients occurs on prolonged standing.

Identification (1) Shake well 1 g of Acrinol and Zinc Oxide Oil with 10 mL of diethyl ether, 2 mL of acetic acid (100) and 10 mL of water, and separate the water layer. Shake the layer with 5 mL of hydrochloric acid and 2 to 3 drops of sodium nitrite TS, and allow to stand: a dark red color is produced (acrinol).

(2) Place 1 g of Acrinol and Zinc Oxide Oil in a crucible, melt by warming, heat, gradually raising the temperature until the mass is thoroughly charred, and then ignite strongly: a yellow color is produced, and disappears on cooling. To the residue add 10 mL of water and 5 mL of dilute

hydrochloric acid, filter after thorough shaking, and to the filtrate add 2 to 3 drops of potassium hexacyanoferrate (II) TS: a white precipitate is formed (zinc oxide).

(3) Shake well 0.2 g of Acrinol and Zinc Oxide Oil with 20 mL of ethanol (95) and 1 mL of acetic acid (100), centrifuge, filter, and use the filtrate as the sample solution. Separately, dissolve 5 mg of acrinol in 50 mL of ethanol (95) and 2.5 mL of acetic acid (100), and use this solution as the standard solution. Perform the test with these solutions as directed under Thin-layer Chromatography <2.03>. Spot 5 μ L each of the sample solution and standard solution on a plate of silica gel for thin-layer chromatography. Develop the plate with a mixture of 2-propanol and acetic acid (100) (9:1) to a distance of about 10 cm, and air-dry the plate. Examine under ultraviolet light (main wavelength: 365 nm): the spots from the sample solution and standard solution exhibit a blue fluorescence and show the same *R_f* value.

Assay Transfer about 0.8 g of well-mixed Acrinol and Zinc Oxide Oil, accurately weighed, to a crucible, heat, gradually raising the temperature until the mass is thoroughly charred, then strongly heat until the residue becomes yellow. After cooling, dissolve the residue by addition of 1 mL of water and 1.5 mL of hydrochloric acid, and add water to make exactly 100 mL. Pipet 20 mL of this solution, add 80 mL of water, then add sodium hydroxide solution (1 in 50) until slightly precipitates appear, and add 5 mL of ammonia-ammonium chloride buffer solution (pH 10.7). Titrate <2.50> with 0.05 mol/L disodium dihydrogen ethylenediamine tetraacetate VS (indicator: 40 mg of eriochrome black T-sodium chloride indicator).

Each mL of 0.05 mol/L disodium dihydrogen ethylenediamine tetraacetate VS
= 4.069 mg of ZnO

Containers and storage Containers—Tight containers.
Storage—Light-resistant.

Compound Acrinol and Zinc Oxide Oil

複方アクリノール・チンク油

Method of preparation

Acrinol Hydrate, very finely powdered	10 g
Zinc Oxide Oil	650 g
Ethyl Aminobenzoate, finely powdered	50 g
White Beeswax	20 g
Hydrophilic Petrolatum	270 g
To make 1000 g	

Prepare by mixing the above ingredients.

Description Compound Acrinol and Zinc Oxide Oil is light yellow to yellow in color.

Identification (1) Shake well 1 g of Compound Acrinol and Zinc Oxide Oil with 10 mL of diethyl ether, 2 mL of acetic acid (100) and 10 mL of water, and separate the water layer. Shake the layer with 5 mL of hydrochloric acid and 2 to 3 drops of sodium nitrite TS, and allow to stand: a dark red color is produced (acrinol).

(2) Place 1 g of Compound Acrinol and Zinc Oxide Oil in a crucible, melt by warming, heat, gradually raising the temperature until the mass is thoroughly charred, and then ignite strongly: a yellow color is produced, and disappears

on cooling. To the residue add 10 mL of water and 5 mL of dilute hydrochloric acid, shake well, and filter. To the filtrate add 2 to 3 drops of potassium hexacyanoferrate (II) TS: a white precipitate is produced (zinc oxide).

(3) Shake well 0.2 g of Compound Acrinol and Zinc Oxide Oil with 20 mL of ethanol (95) and 1 mL of acetic acid (100), centrifuge, filter, and use the filtrate as the sample solution. Separately, dissolve 5 mg of acrinol and 25 mg of ethyl aminobenzoate in 50 mL of ethanol (95) and in 2.5 mL of acetic acid (100), respectively, and use both solutions as the standard solutions (1) and (2). Perform the test with these solutions as directed under Thin-layer Chromatography <2.03>. Spot 5 μ L each of the sample solution and standard solutions on a plate of silica gel with fluorescent indicator for thin-layer chromatography. Develop the plate with a mixture of 2-propanol and acetic acid (100) (9:1) to a distance of about 10 cm, and air-dry the plate. Examine under ultraviolet light (main wavelength: 365 nm): the spots from the sample solution and standard solution (1) exhibit a blue fluorescence, and show the same *R_f* value. Also examine under ultraviolet light (main wavelength: 254 nm): the spots from the sample solution and standard solution (2) exhibit a purple color, and show the same *R_f* value.

Containers and storage Containers—Tight containers.
Storage—Light-resistant.

Acrinol and Zinc Oxide Ointment

アクリノール・亜鉛華軟膏

Method of preparation

Acrinol Hydrate, very finely powdered	10 g
Zinc Oxide Ointment	990 g
To make 1000 g	

Prepare as directed under Ointments, with the above ingredients.

Description Acrinol and Zinc oxide Ointment is yellow in color.

Identification (1) Shake 0.5 g of Acrinol and Zinc Oxide Ointment with 5 mL of diethyl ether, 5 mL of dilute hydrochloric acid and 2 to 3 drops of sodium nitrite TS, and allow to stand: a dark red color develops in the water layer (acrinol).

(2) Ignite 0.5 g of Acrinol and Zinc Oxide Ointment to char, and dissolve the residue in 5 mL of dilute hydrochloric acid: the solution responds to Qualitative Tests <1.09> for zinc salt.

(3) Shake 0.5 g of Acrinol and Zinc Oxide Ointment with 5 mL of diethyl ether, 1 mL of acetic acid (100) and 5 mL of water, separate the water layer, and use the water layer as the sample solution. Dissolve 5 mg of acrinol in 1 mL of acetic acid (100) and 5 mL of water, and use this solution as the standard solution. Perform the test with these solutions as directed under Thin-layer Chromatography <2.03>. Spot 5 μ L each of the sample solution and standard solution on a plate of silica gel for thin-layer chromatography. Develop the plate with a mixture of diethyl ether, ethanol (95) and acetic acid (100) (40:10:1) to a distance of about 10 cm, and air-dry the plate. Examine under ultraviolet light (main wavelength: 365 nm): the spots from the sample solution and the standard solution exhibit a blue fluorescence and show the same *R_f* value.

Containers and storage Containers—Tight containers.
Storage—Light-resistant.

Actinomycin D

Dactinomycin

アクチノマイシン D

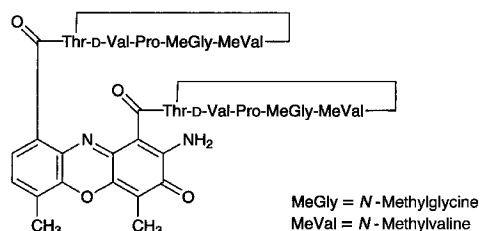

$C_{62}H_{86}N_{12}O_{16}$: 1255.42
[50-76-0]

Actinomycin D is a peptide substance having antitumor activity produced by the growth of *Streptomyces parvulus*.

It, when dried, contains not less than 950 μg (potency) and not more than 1030 μg (potency) per mg. The potency of Actinomycin D is expressed as mass (potency) of actinomycin D ($C_{62}H_{86}N_{12}O_{16}$).

Description Actinomycin D occurs as an orange-red to red crystalline powder.

It is freely soluble in acetone, sparingly soluble in acetonitrile and in methanol, slightly soluble in ethanol (99.5), and very slightly soluble in water.

Identification (1) Determine the absorption spectrum of a solution of Actinomycin D in methanol (3 in 100,000) as directed under Ultraviolet-visible Spectrophotometry <2.24>, and compare the spectrum with the Reference Spectrum or the spectrum of a solution of Actinomycin D RS prepared in the same manner as the sample solution: both spectra exhibit similar intensities of absorption at the same wavelengths.

(2) Dissolve 0.1 g each of Actinomycin D and Actinomycin D RS in 10 mL of acetone, and use these solutions as the sample solution and standard solution. Perform the test with these solutions as directed under Thin-layer Chromatography <2.03>. Spot 10 μL each of the sample solution and standard solution on a plate of silica gel with fluorescent indicator for thin-layer chromatography. Develop the plate with a mixture of 1-butanol, water and methanol (4:2:1) to a distance of about 10 cm, and air-dry the plate. Examine under ultraviolet light (main wavelength: 254 nm): the R_f value of the principal spot from the sample solution is the same as that from the standard solution.

Optical rotation <2.49> $[\alpha]_D^{20}$: $-293 - -329^\circ$ (after drying, 10 mg, methanol, 10 mL, 100 mm).

Loss on drying <2.41> Not more than 5.0% (1 g, in vacuum, 60°C , 3 hours).

Assay Weigh accurately an amount of Actinomycin D and Actinomycin D RS, previously dried, equivalent to about 60 mg (potency), dissolve each in the mobile phase to make exactly 50 mL, and use these solutions as the sample solution and standard solution. Perform the test with exactly 25 μL each of the sample solution and standard solution as directed under Liquid Chromatography <2.01> according to the following conditions, and determine the peak area of actino-

mycin D, A_T and A_S , in each solution.

$$\text{Amount } [\mu\text{g (potency)}] \text{ of actinomycin D } (C_{62}H_{86}N_{12}O_{16}) \\ = M_S \times A_T/A_S \times 1000$$

M_S : Amount [mg (potency)] of Actinomycin D RS taken

Operating conditions—

Detector: An ultraviolet absorption photometer (wavelength: 254 nm).

Column: A stainless steel column 3.9 mm in inside diameter and 30 cm in length, packed with octadecylsilanized silica gel for liquid chromatography (10 μm in particle diameter).

Column temperature: A constant temperature of about 25°C .

Mobile phase: A mixture of 0.02 mol/L acetic acid-sodium acetate TS and acetonitrile (25:23).

Flow rate: Adjust so that the retention time of actinomycin D is about 23 minutes.

System suitability—

System performance: When the procedure is run with 25 μL of the standard solution under the above operating conditions, the number of theoretical plates and the symmetry factor of the peak of actinomycin D are not less than 2000 and not more than 1.5, respectively.

System repeatability: When the test is repeated 5 times with 25 μL of the standard solution under the above operating conditions, the relative standard deviation of the peak area of actinomycin D is not more than 2.0%.

Containers and storage Containers—Tight containers.

Storage—Light-resistant.

Adrenaline

Epinephrine

アドレナリン

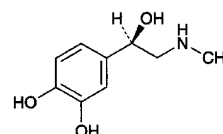

$C_9H_{13}NO_3$: 183.20

4-[(1*R*)-1-Hydroxy-2-(methylamino)ethyl]benzene-1,2-diol
[51-43-4]

Adrenaline, when dried, contains not less than 98.0% and not more than 101.0% of adrenaline ($C_9H_{13}NO_3$).

Description Adrenaline occurs as a white to grayish white crystalline powder.

It is freely soluble in formic acid and in acetic acid (100), very slightly soluble in water, and practically insoluble in methanol and in ethanol (99.5).

It dissolves in dilute hydrochloric acid.

It gradually changes to brown in color by air and by light.

Identification (1) Determine the absorption spectrum of a solution of Adrenaline in 0.01 mol/L hydrochloric acid TS (1 in 25,000) as directed under Ultraviolet-visible Spectrophotometry <2.24>, and compare the spectrum with the Reference Spectrum: both spectra exhibit similar intensities of absorption at the same wavelengths.

(2) Determine the infrared absorption spectrum of Adrenaline as directed in the potassium bromide disk method under Infrared Spectrophotometry <2.25>, and com-

pare the spectrum with the Reference Spectrum: both spectra exhibit similar intensities of absorption at the same wave numbers.

Optical rotation <2.49> $[\alpha]_D^{20}$: $-50.0 - -53.5^\circ$ (after drying, 1 g, 1 mol/L hydrochloric acid TS, 25 mL, 100 mm).

Purity (1) Clarity and color of solution—Dissolve 0.10 g of Adrenaline in 10 mL of dilute hydrochloric acid: the solution is clear, and is not more colored than Matching Fluid A.

(2) Heavy metals <1.07>—Proceed with 1.0 g of Adrenaline according to Method 4, and perform the test. Prepare the control solution with 2.0 mL of Standard Lead Solution (not more than 20 ppm).

(3) Adrenalone—Dissolve 50 mg of Adrenaline in 0.05 mol/L hydrochloric acid TS to make exactly 25 mL, and determine the absorbance of this solution at 310 nm as directed under Ultraviolet-visible Spectrophotometry <2.24>: it is not more than 0.2.

(4) Noradrenaline—Dissolve 0.20 g of Adrenaline in 1 mL of formic acid, add methanol to make exactly 10 mL, and use this solution as the sample solution. Separately, dissolve 8.0 mg of Noradrenaline Bitartrate RS in methanol to make exactly 10 mL, and use this solution as the standard solution. Perform the test with these solutions as directed under Thin-layer Chromatography <2.03>. Spot 5 μ L each of the sample solution and standard solution on a plate of silica gel with fluorescent indicator for thin-layer chromatography. Develop the plate with a mixture of 1-butanol, water and formic acid (7:2:1) to a distance of about 10 cm, and air-dry the plate. Spray evenly Folin's TS on the plate: the spot obtained from the sample solution, corresponding to the spot from the standard solution, is not more intense than the spot from the standard solution.

Loss on drying <2.41> Not more than 1.0% (1 g, in vacuum, silica gel, 18 hours).

Residue on ignition <2.44> Not more than 0.1% (1 g).

Assay Weigh accurately about 0.3 g of Adrenaline, previously dried, dissolve in 50 mL of acetic acid (100), and titrate <2.50> with 0.1 mol/L perchloric acid VS (potentiometric titration). Perform a blank determination in the same manner, and make any necessary correction.

Each mL of 0.1 mol/L perchloric acid VS
= 18.32 mg of $C_9H_{13}NO_3$

Containers and storage Containers—Tight containers.
Storage—Light-resistant, and under Nitrogen atmosphere.

Adrenaline Injection

Epinephrine Injection

アドレナリン注射液

Adrenaline Injection is an aqueous injection.

It contains not less than 0.085 w/v% and not more than 0.115 w/v% of adrenaline ($C_9H_{13}NO_3$: 183.20).

Method of preparation Dissolve Adrenaline in diluted Hydrochloric Acid (9 in 10,000), and prepare as directed under Injections.

Description Adrenaline Injection is a colorless, clear liquid.

It changes gradually to pale red and then to brown on exposure to air and light.

pH: 2.3 – 5.0

Identification (1) To 1 mL of Adrenaline Injection add 4 mL of water and 1 drop of iron (III) chloride TS: a deep green color is produced, and it gradually changes to red.

(2) Place 1 mL each of Adrenaline Injection in test tubes A and B, and proceed as directed in the Identification (2) under Adrenaline.

Extractable volume <6.05> It meets the requirement.

Assay Pipet 30 mL of Adrenaline Injection into a separator, add 25 mL of carbon tetrachloride, shake vigorously for 1 minute, allow the liquids to separate, and discard the carbon tetrachloride. Repeat this procedure three times. Rinse the stopper and mouth of the separator with a small amount of water. Add 0.2 mL of starch TS, then while swirling the separator add iodine TS dropwise until a persistent blue color develops, and immediately add sodium thiosulfate TS to discharge the blue color. Add 2.1 g of sodium hydrogen carbonate to the liquid in the separator, preventing it from coming in contact with the mouth of the separator, and shake until most of the sodium hydrogen carbonate dissolves. Rapidly inject 1.0 mL of acetic anhydride into the contents of the separator. Immediately stopper the separator loosely, and allow to stand until the evolution of gas ceases. Shake vigorously, allow to stand for 5 minutes, extract with six 25-mL portions of chloroform, and filter each chloroform extract through a pledget of absorbent cotton. Evaporate the combined chloroform extracts on a water bath in a current of air to 3 mL, completely transfer this residue by means of small portions of chloroform to a tared beaker, and heat again to evaporate to dryness. Dry the residue at 105°C for 30 minutes, cool in a desiccator (silica gel), and accurately measure the mass M (mg) of the dried residue. Dissolve in chloroform to make exactly 5 mL, and determine the optical rotation <2.49> $[\alpha]_D^{20}$ using a 100-mm cell.

Amount (mg) of adrenaline ($C_9H_{13}NO_3$)
= $M \times \{0.5 + (0.5 \times |[\alpha]_D^{20}|)/93\} \times 0.592$

Containers and storage Containers—Hermetic containers, and colored containers may be used.

Storage—Light-resistant.

Adrenaline Solution

Epinephrine Solution

アドレナリン液

Adrenaline Solution contains not less than 0.085 w/v% and not more than 0.115 w/v% of adrenaline ($C_9H_{13}NO_3$: 183.20)

Method of preparation

Adrenaline	1 g
Sodium Chloride	8.5 g
Diluted Hydrochloric Acid (9 in 100)	10 mL
Stabilizer	a suitable quantity
Preservative	a suitable quantity
Purified Water or Purified Water in Containers	a sufficient quantity
To make 1000 mL	

Prepare by mixing the above ingredients.

Description Adrenaline Solution is clear, colorless or

slightly reddish liquid.

It changes gradually to pale red and then to brown on exposure to air and light.

pH: 2.3 – 5.0

Identification Proceed as directed in the Identification under Adrenaline Injection.

Assay Proceed as directed in the Assay under Adrenaline Injection.

$$\begin{aligned} \text{Amount (mg) of adrenaline (C}_9\text{H}_{13}\text{NO}_3) \\ = M \times \{0.5 + (0.5 \times |[\alpha]_D^{20}|)/93\} \times 0.592 \end{aligned}$$

Containers and storage Containers—Tight containers.

Storage—Light-resistant.

Afloqualone

アフロクアロン

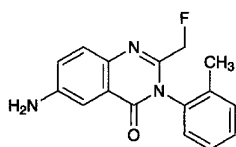

C₁₆H₁₄FN₃O: 283.30

6-Amino-2-fluoromethyl-3-(2-tolyl)-3H-quinazolin-4-one
[56287-74-2]

Afloqualone, when dried, contains not less than 98.5% of afloqualone (C₁₆H₁₄FN₃O).

Description Afloqualone occurs as white to light yellow, crystals or crystalline powder.

It is soluble in acetonitrile, sparingly soluble in ethanol (99.5), and practically insoluble in water.

It is gradually colored by light.

Melting point: about 197°C (with decomposition).

Identification (1) Conduct this procedure without exposure to light, using light-resistant containers. Determine the absorption spectrum of a solution of Afloqualone in ethanol (99.5) (1 in 150,000) as directed under Ultraviolet-visible Spectrophotometry <2.24>, and compare the spectrum with the Reference Spectrum: both spectra exhibit similar intensities of absorption at the same wavelengths.

(2) Determine the infrared absorption spectrum of Afloqualone, previously dried, as directed in the potassium bromide disk method under Infrared Spectrophotometry <2.25>, and compare the spectrum with the Reference Spectrum: both spectra exhibit similar intensities of absorption at the same wave numbers.

Purity (1) Acidity or alkalinity—Take 1.0 g of Afloqualone in a light-resistant vessel, add 20 mL of freshly boiled and cooled water, shake well, and filter. To 10 mL of the filtrate add 2 drops of bromothymol blue TS: a yellow color develops. The color changes to blue by adding 0.20 mL of 0.01 mol/L sodium hydroxide TS.

(2) Heavy metals <1.07>—Proceed with 2.0 g of Afloqualone in a platinum crucible according to Method 2, and perform the test. Prepare the control solution with 2.0 mL of Standard Lead Solution (not more than 10 ppm).

(3) Related substances—Conduct this procedure without exposure to light, using light-resistant vessels. Dissolve 10 mg of Afloqualone in 25 mL of the mobile phase, and use this solution as the sample solution. Pipet 3 mL of the sample solution, add the mobile phase to make exactly 100 mL.

Pipet 2 mL of this solution, add the mobile phase to make exactly 20 mL, and use this solution as the standard solution. Perform the test with exactly 20 μL each of the sample solution and standard solution as directed under Liquid Chromatography <2.01> according to the following conditions. Determine each peak area by the automatic integration method: the total area of the peaks other than afloqualone from the sample solution is not larger than the peak area of afloqualone from the standard solution.

Operating conditions—

Detector: An ultraviolet absorption photometer (wavelength: 254 nm).

Column: A stainless steel column 4.6 mm in inside diameter and 15 cm in length, packed with octylsilylated silica gel for liquid chromatography (5 μm in particle diameter).

Column temperature: A constant temperature of about 40°C.

Mobile phase: Dissolve 7.2 g of disodium hydrogen phosphate dodecahydrate in 1000 mL of water, adjust to pH 5.5 with diluted phosphoric acid (1 in 10). To 600 mL of this solution add 400 mL of acetonitrile.

Flow rate: Adjust so that the retention time of afloqualone is about 5.5 minutes.

Time span of measurement: About 4 times as long as the retention time of afloqualone, beginning after the solvent peak.

System suitability—

Test for required detectability: Pipet 5 mL of the standard solution, add the mobile phase to make exactly 25 mL, and confirm that the peak area of afloqualone obtained with 20 μL of this solution is equivalent to 15 to 25% of that with 20 μL of the standard solution.

System performance: Dissolve 0.01 g of Afloqualone in a suitable amount of the mobile phase, add 5 mL of a solution of propyl parahydroxybenzoate in the mobile phase (1 in 2000) and the mobile phase to make 100 mL. When the procedure is run with 20 μL of this solution under the above operating conditions, afloqualone and propyl parahydroxybenzoate are eluted in this order with the resolution between these peaks being not less than 4.

System repeatability: When the test is repeated 6 times with 20 μL of the standard solution under the above operating conditions, the relative standard deviation of the peak areas of afloqualone is not more than 5%.

Loss on drying <2.41> Not more than 0.5% (1 g, in vacuum, 60°C, 2 hours).

Residue on ignition <2.44> Not more than 0.1% (1.0 g, platinum crucible).

Assay Weigh accurately about 0.4 g of Afloqualone, previously dried, dissolve in 10 mL of hydrochloric acid and 40 mL of water, and add 10 mL of a solution of potassium bromide (3 in 10). After cooling at 15°C or below, titrate <2.50> with 0.1 mol/L sodium nitrite VS according to the potentiometric titration or amperometric titration under the Electrode Titration method.

$$\begin{aligned} \text{Each mL of 0.1 mol/L sodium nitrite} \\ = 28.33 \text{ mg of C}_{16}\text{H}_{14}\text{FN}_3\text{O} \end{aligned}$$

Containers and storage Containers—Tight containers.

Storage—Light-resistant.

Ajmaline

アジマリン

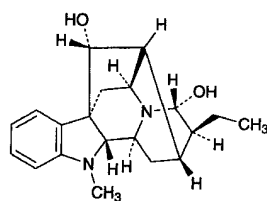

$C_{20}H_{26}N_2O_2$: 326.43
(17*R*,21*R*)-Ajmalan-17,21-diol
[4360-12-7]

Ajmaline, when dried, contains not less than 96.0% of ajmaline ($C_{20}H_{26}N_2O_2$).

Description Ajmaline occurs as a white to pale yellow crystalline powder. It is odorless, and has a bitter taste.

It is freely soluble in acetic anhydride and in chloroform, sparingly soluble in methanol, in ethanol (95), in acetone and in diethyl ether, and very slightly soluble in water.

It dissolves in dilute hydrochloric acid.

Melting point: about 195°C (with decomposition).

Identification (1) Dissolve 0.05 g of Ajmaline in 5 mL of methanol, and use this solution as the sample solution. Add 3 mL of nitric acid to 1 mL of the sample solution: a deep red color develops.

(2) Spot the sample solution of (1) on filter paper, and spray Dragendorff's TS: an orange color develops.

Absorbance <2.24> $E_{1\text{cm}}^{1\%}$ (249 nm): 257 – 271 (after drying, 2 mg, ethanol (95), 100 mL).

$E_{1\text{cm}}^{1\%}$ (292 nm): 85 – 95 (after drying, 2 mg, ethanol (95), 100 mL).

Optical rotation <2.49> $[\alpha]_D^{20}$: +136 – +151° (after drying, 0.5 g, chloroform, 50 mL, 100 mm).

Purity Related substances—Dissolve 0.10 g of Ajmaline in 10 mL of chloroform, and use this solution as the sample solution. Pipet 1 mL of the sample solution, add chloroform to make exactly 100 mL, and use this solution as the standard solution. Perform the test with these solutions as directed under Thin-layer Chromatography <2.03>. Spot 10 μL each of the sample solution and standard solution on a plate of silica gel with fluorescent indicator for thin-layer chromatography. Develop the plate with a mixture of chloroform, acetone and diethylamine (5:4:1) to a distance of about 10 cm, and air-dry the plate. Examine under ultraviolet light (main wavelength: 254 nm): the spots other than the principal spot obtained from the sample solution are not more intense than the spot from the standard solution.

Loss on drying <2.41> Not more than 1.0% (0.6 g, in vacuum, 80°C, 3 hours).

Residue on ignition <2.44> Not more than 0.2% (0.5 g).

Assay Weigh accurately about 0.3 g of Ajmaline, previously dried, dissolve in 50 mL of acetic anhydride and 50 mL of acetone for nonaqueous titration, and titrate <2.50> with 0.05 mol/L perchloric acid VS (potentiometric titration). Perform a blank determination in the same manner, and make any necessary correction.

Each mL of 0.05 mol/L perchloric acid VS
= 16.32 mg of $C_{20}H_{26}N_2O_2$

Containers and storage Containers—Well-closed containers.

Storage—Light-resistant.

Ajmaline Tablets

アジマリン錠

Ajmaline Tablets contain not less than 90.0% and not more than 110.0% of the labeled amount of ajmaline ($C_{20}H_{26}N_2O_2$: 326.43).

Method of preparation Prepare as directed under Tablets, with Ajmaline.

Identification (1) Shake a quantity of powdered Ajmaline Tablets, equivalent to 0.1 g of Ajmaline, with 30 mL of chloroform, and filter. Evaporate the filtrate on a water bath to dryness. With the residue, proceed as directed in the Identification under Ajmaline.

(2) Dissolve 0.01 g of the residue of (1) in 100 mL of ethanol (95). To 10 mL of this solution add ethanol (95) to make 50 mL, and determine the absorption spectrum of the solution as directed under Ultraviolet-visible Spectrophotometry <2.24>: it exhibits maxima between 247 nm and 251 nm and between 291 nm and 294 nm, and a minimum between 269 nm and 273 nm.

Uniformity of dosage units <6.02> Perform the test according to the following method: it meets the requirement of the Content uniformity test.

To 1 tablet of Ajmaline Tablets add 150 mL of 2nd fluid for dissolution test, shake to disintegrate the tablet, then add 2nd fluid for dissolution test to make exactly 200 mL, and filter this solution through a membrane filter with a pore size not exceeding 0.8 μm. Discard the first 10 mL of the filtrate, pipet V mL of the subsequent filtrate equivalent to about 0.5 mg of ajmaline ($C_{20}H_{26}N_2O_2$), add 2nd fluid for dissolution test to make exactly 10 mL, and use this solution as the sample solution. Separately, weigh accurately about 25 mg of ajmaline for assay, previously dried in vacuum at 80°C for 3 hours, dissolve in 2nd fluid for dissolution test to make exactly 500 mL, and use this solution as the standard solution. Determine the absorbances at 288 nm, A_T and A_S , of the sample solution and standard solution as directed under Ultraviolet-visible Spectrophotometry <2.24>.

$$\begin{aligned} &\text{Amount (mg) of ajmaline (C}_{20}\text{H}_{26}\text{N}_2\text{O}_2) \\ &= M_S \times A_T/A_S \times 1/V \times 4 \end{aligned}$$

M_S : Amount (mg) of ajmaline for assay taken

Dissolution <6.10> When the test is performed at 100 revolutions per minute according to the Paddle method, using 900 mL of 2nd fluid for dissolution test as the dissolution medium, the dissolution rate in 60 minutes of Ajmaline Tablets is not less than 75%.

Start the test with 1 tablet of Ajmaline Tablets, withdraw not less than 20 mL of the medium at the specified minute after starting the test, and filter through a membrane filter with a pore size not exceeding 0.8 μm. Discard not less than 10 mL of the first filtrate, pipet V mL of the subsequent filtrate, add the dissolution medium to make exactly V' mL so that each mL contains about 56 μg of ajmaline ($C_{20}H_{26}N_2O_2$), and use this solution as the sample solution. Separately, weigh accurately about 28 mg of ajmaline for assay, previously dried in vacuum at 80°C for 3 hours, dissolve in the dissolution medium to make exactly 500 mL, and

use this solution as the standard solution. Determine the absorbances, A_T and A_S , of the sample solution and standard solution at 288 nm as directed under Ultraviolet-visible Spectrophotometry <2.24>.

Dissolution rate (%) with respect to the labeled amount of ajmaline ($C_{20}H_{26}N_2O_2$)

$$= M_S \times A_T / A_S \times V' / V \times 1 / C \times 180$$

M_S : Amount (mg) of ajmaline for assay taken

C : Labeled amount (mg) of ajmaline ($C_{20}H_{26}N_2O_2$) in 1 tablet

Assay Weigh accurately and powder not less than 20 Ajmaline Tablets. Weigh accurately a portion of the powder, equivalent to about 0.3 g of ajmaline ($C_{20}H_{26}N_2O_2$), add 15 mL of ammonia solution (28), and extract with four 25-mL portions of chloroform. Combine the chloroform extracts, wash with 10 mL of water, add 5 g of anhydrous sodium sulfate, shake well, and filter. Wash the container and the residue with two 10-mL portions of chloroform, and filter. Evaporate the combined filtrate on a water bath to dryness, dissolve the residue in 50 mL of acetic anhydride and 50 mL of acetone for nonaqueous titration, and titrate <2.50> with 0.05 mol/L perchloric acid VS (potentiometric titration). Perform a blank determination in the same manner, and make any necessary correction.

Each mL of 0.05 mol/L perchloric acid VS
= 16.32 mg of $C_{20}H_{26}N_2O_2$

Containers and storage Containers—Well-closed containers.

Storage—Light-resistant.

Alacepril

アラセプリル

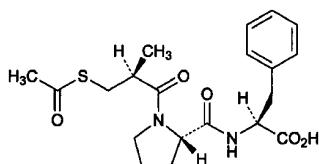

$C_{20}H_{26}N_2O_5S$: 406.50
(2*S*)-2-[(2*S*)-1-[(2*S*)-3-(Acetylsulfanyl)-2-methylpropanoyl]pyrrolidine-2-carbonyl]amino-3-phenylpropanoic acid
[74258-86-9]

Alacepril, when dried, contains not less than 98.5% and not more than 101.0% of alacepril ($C_{20}H_{26}N_2O_5S$).

Description Alacepril occurs as white, crystals or crystalline powder.

It is freely soluble in methanol, soluble in ethanol (95), and slightly soluble in water.

It dissolves in sodium hydroxide TS.

Identification (1) To 20 mg of Alacepril add 0.1 g of sodium hydroxide, and heat gradually to melt: the gas evolved changes the color of a moisten red litmus paper to blue. After cooling, to the melted substance add 2 mL of water, shake, and add 1 mL of lead (II) acetate TS: a brown to black precipitate is formed.

(2) Determine the infrared absorption spectrum of Alacepril, previously dried, as directed in the potassium bromide disk method under Infrared Spectrophotometry <2.25>.

and compare the spectrum with the Reference Spectrum: both spectra exhibit similar intensities of absorption at the same wave numbers.

Optical rotation <2.49> $[\alpha]_D^{20}$: $-81 - -85^\circ$ (after drying, 0.25 g, ethanol (95), 25 mL, 100 mm).

Melting point <2.60> 153 – 157°C

Purity (1) Chloride <1.03>—Dissolve 0.5 g of Alacepril in 30 mL of methanol, add 6 mL of dilute nitric acid and water to make 50 mL, and perform the test with this solution as the test solution. Prepare the control solution as follows: to 0.30 mL of 0.01 mol/L hydrochloric acid VS add 30 mL of methanol, 6 mL of dilute nitric acid and water to make 50 mL (not more than 0.021%).

(2) Sulfate <1.14>—Dissolve 0.5 g of Alacepril in 30 mL of methanol, add 1 mL of dilute hydrochloric acid and water to make 50 mL, and perform the test using this solution as the test solution. Prepare the control solution as follows: to 0.50 mL of 0.005 mol/L sulfuric acid VS add 30 mL of methanol, 1 mL of dilute hydrochloric acid and water to make 50 mL (not more than 0.048%).

(3) Heavy metals <1.07>—Proceed with 1.0 g of Alacepril according to Method 2, and perform the test. Prepare the control solution with 2.0 mL of Standard Lead Solution (not more than 20 ppm).

(4) Related substances—Dissolve 50 mg of Alacepril in 5 mL of ethanol (95), and use this solution as the sample solution. Pipet 1 mL of the sample solution, add ethanol (95) to make exactly 200 mL, and use this solution as the standard solution. Perform the test with exactly 10 μ L each of the sample solution and standard solution as directed under Liquid Chromatography <2.01> according to the following conditions, and determine each peak area by the automatic integration method: the area of the peak other than alacepril from the sample solution is not larger than 2/5 times the peak area of alacepril from the standard solution, and the total area of the peaks other than alacepril from the sample solution is not larger than the peak area of alacepril from the standard solution. For the areas of the peaks, having the relative retention times of about 2.3 and about 2.6 to alacepril, multiply their correction factors, 1.5 and 1.9, respectively.

Operating conditions—

Detector: An ultraviolet absorption photometer (wavelength: 254 nm).

Column: A stainless steel column 4.6 mm in inside diameter and 15 cm in length, packed with octadecylsilanized silica gel for liquid chromatography (5 μ m in particle diameter).

Column temperature: A constant temperature of about 40°C.

Mobile phase: A mixture of diluted acetic acid (100) (1 in 100), acetonitrile, methanol and tetrahydrofuran (6:2:1:1).

Flow rate: Adjust so that the retention time of alacepril is about 5 minutes.

Time span of measurement: About 3 times as long as the retention time of alacepril, beginning after the solvent peak.

System suitability—

Test for required detectability: To exactly 4 mL of the standard solution add ethanol (95) to make exactly 10 mL. Confirm that the peak area of alacepril obtained with 10 μ L of this solution is equivalent to 30 to 50% of that obtained with 10 μ L of the standard solution.

System performance: Dissolve 20 mg of Alacepril in 50 mL of a solution of propyl parahydroxybenzoate in ethanol (95) (1 in 80,000). When the procedure is run with 10 μ L of this solution under the above operating conditions, alacepril

and propyl parahydroxybenzoate are eluted in this order with the resolution between these peaks being not less than 7.

System repeatability: When the test is repeated 6 times with 10 μ L of the standard solution under the above operating conditions, the relative standard deviation of the peak area of alacepril is not more than 2.0%.

Loss on drying <2.41> Not more than 1.0% (1 g, 105°C, 3 hours).

Residue on ignition <2.44> Not more than 0.1% (1 g).

Assay Weigh accurately about 0.6 g of Alacepril, previously dried, dissolve in 75 mL of a mixture of methanol and water (2:1), and titrate <2.50> with 0.1 mol/L sodium hydroxide VS (potentiometric titration). Perform a blank determination in the same manner, and make any necessary correction.

$$\begin{aligned} \text{Each mL of 0.1 mol/L sodium hydroxide VS} \\ = 40.65 \text{ mg of } C_{20}H_{26}N_2O_5S \end{aligned}$$

Containers and storage Containers—Tight containers.

Alacepril Tablets

アラセプリル錠

Alacepril Tablets contain not less than 95.0% and not more than 105.0% of the labeled amount of alacepril ($C_{20}H_{26}N_2O_5S$; 406.50).

Method of preparation Prepare as directed under Tablets, with Alacepril.

Identification Shake well a quantity of powdered Alacepril Tablets, equivalent to 0.1 g of Alacepril, with 10 mL of ethanol (95), filter, and use the filtrate as the sample solution. Separately, dissolve 10 mg of alacepril in 1 mL of ethanol (95), and use this solution as the standard solution. Perform the test with these solutions as directed under Thin-layer Chromatography <2.03>. Spot 5 μ L each of the sample solution and standard solution on a plate of silica gel with fluorescent indicator for thin-layer chromatography, develop the plate with a mixture of ethanol (99.5) and hexane (2:1) to a distance of about 10 cm, and air-dry the plate. Examine under ultraviolet light (main wavelength: 254 nm): the principal spot from the sample solution and the spot from the standard solution show the same color tone and *R_f* value.

Uniformity of dosage units <6.02> Perform the Mass variation test, or the Content uniformity test according to the following method: it meets the requirement.

To 1 tablet of Alacepril Tablets add 2 mL of water, sonicate to disperse the particle, and add exactly 2 mL of the internal standard solution for every 10 mg of alacepril ($C_{20}H_{26}N_2O_5S$). To this solution add a suitable amount of methanol, extract for 15 minutes with the aid of ultrasonic wave while occasional shaking, and shake more 15 minutes. Add methanol to make *V* mL so that each mL of the solution contains about 0.5 mg of alacepril ($C_{20}H_{26}N_2O_5S$), centrifuge, and use the supernatant liquid as the sample solution. Separately, weigh accurately about 25 mg of alacepril for assay, previously dried at 105°C for 3 hours, add exactly 5 mL of the internal standard solution and methanol to make 50 mL, and use this solution as the standard solution. Perform the test with 10 μ L each of the sample solution and standard solution as directed under Liquid Chromatography

<2.01> according to the following conditions, and calculate the ratios, Q_T and Q_S , of the peak area of alacepril to that of the internal standard.

$$\begin{aligned} \text{Amount (mg) of alacepril } (C_{20}H_{26}N_2O_5S) \\ = M_S \times Q_T / Q_S \times V / 50 \end{aligned}$$

M_S : Amount (mg) of alacepril for assay taken

Internal standard solution—A solution of propyl parahydroxybenzoate in methanol (3 in 20,000).

Operating conditions—

Proceed as directed in the operating conditions in the Assay.

System suitability—

Proceed as directed in the system suitability in the Assay.

Dissolution <6.10> When the test is performed at 50 revolutions per minute according to the Paddle method, using 900 mL of water as the dissolution medium, the dissolution rate of a 12.5-mg tablet and a 25-mg tablet in 30 minutes is not less than 75%, and that of a 50-mg tablet in 30 minutes is not less than 70%.

Start the test with 1 tablet of Alacepril Tablets, withdraw not less than 20 mL of the medium at the specified minute after starting the test, and filter through a membrane filter with a pore size not exceeding 0.45 μ m. Discard not less than 10 mL of the first filtrate, pipet *V'* mL of the subsequent filtrate, add water to make exactly *V'* mL so that each mL contains about 14 μ g of alacepril ($C_{20}H_{26}N_2O_5S$), and use this solution as the sample solution. Separately, weigh accurately about 14 mg of alacepril for assay, previously dried at 105°C for 3 hours, dissolve in 2 mL of methanol, and add water to make exactly 100 mL. Pipet 5 mL of this solution, add water to make exactly 50 mL, and use this solution as the standard solution. Determine the absorbances, A_{T1} and A_{S1} , at 230 nm, and A_{T2} and A_{S2} , at 300 nm, of the sample solution and standard solution as directed under Ultraviolet-visible Spectrophotometry <2.24>, using water as the blank.

Dissolution rate (%) with respect to the labeled amount of alacepril ($C_{20}H_{26}N_2O_5S$)

$$= M_S \times (A_{T1} - A_{T2}) / (A_{S1} - A_{S2}) \times V' / V \times 1 / C \times 90$$

M_S : Amount (mg) of alacepril for assay taken

C: Labeled amount (mg) of alacepril ($C_{20}H_{26}N_2O_5S$) in 1 tablet

Assay Weigh accurately, and powder not less than 20 Alacepril Tablets. Weigh accurately a portion of the powder, equivalent to about 50 mg of alacepril ($C_{20}H_{26}N_2O_5S$), moisten with 2 mL of water, add exactly 3 mL of the internal standard solution and 40 mL of methanol, sonicate for 15 minutes, cool, and add methanol to make 50 mL. Centrifuge this solution, and use the supernatant liquid as the sample solution. Separately, weigh accurately about 50 mg of alacepril for assay, previously dried at 105°C for 3 hours, add exactly 3 mL of the internal standard solution, dissolve with methanol to make 50 mL, and use this solution as the standard solution. Perform the test with 10 μ L each of the sample solution and standard solution as directed under Liquid Chromatography <2.01> according to the following conditions, and calculate the ratios, Q_T and Q_S , of the peak area of alacepril to that of the internal standard.

$$\text{Amount (mg) of alacepril } (C_{20}H_{26}N_2O_5S) = M_S \times Q_T / Q_S$$

M_S : Amount (mg) of alacepril for assay taken

Internal standard solution—A solution of propyl parahydroxybenzoate in methanol (1 in 2000).

Operating conditions—

Detector: An ultraviolet absorption photometer (wavelength: 254 nm).

Column: A stainless steel column 4.6 mm in inside diameter and 15 cm in length, packed with octadecylsilanized silica gel for liquid chromatography (5 μ m in particle diameter).

Column temperature: A constant temperature of about 40°C.

Mobile phase: A mixture of diluted acetic acid (100) (1 in 100), acetonitrile, methanol and tetrahydrofuran (13:5:1:1).

Flow rate: Adjust so that the retention time of alacepril is about 6 minutes.

System suitability—

System performance: When the procedure is run with 10 μ L of the standard solution under the above operating conditions, alacepril and the internal standard are eluted in this order with the resolution between these peaks being not less than 7.

System repeatability: When the test is repeated 6 times with 10 μ L of the standard solution under the above operating conditions, the relative standard deviation of the ratio of the peak area of alacepril to that of the internal standard is not more than 1.0%.

Containers and storage Containers—Tight containers.

L-Alanine

L-アラニン

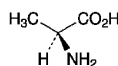
C₃H₇NO₂: 89.09(2S)-2-Aminopropanoic acid
[56-41-7]

L-Alanine, when dried, contains not less than 98.5% and not more than 101.0% of L-alanine (C₃H₇NO₂).

Description L-Alanine occurs as white, crystals or crystalline powder. It has a slightly sweet taste.

It is freely soluble in water and in formic acid, and practically insoluble in ethanol (99.5).

It dissolves in 6 mol/L hydrochloric acid TS.

Identification Determine the infrared absorption spectrum of L-Alanine as directed in the potassium bromide disk method under Infrared Spectrophotometry <2.25>, and compare the spectrum with the Reference Spectrum: both spectra exhibit similar intensities of absorption at the same wave numbers.

Optical rotation <2.49> $[\alpha]_D^{20}$: +13.5 – +15.5° (after drying, 2.5 g, 6 mol/L hydrochloric acid TS, 25 mL, 100 mm).

pH <2.54> Dissolve 1.0 g of L-Alanine in 20 mL of water: the pH of the solution is between 5.7 and 6.7.

Purity (1) Clarity and color of solution—Dissolve 1.0 g of L-Alanine in 10 mL of water: the solution is clear and colorless.

(2) Chloride <1.03>—Perform the test with 0.5 g of L-Alanine. Prepare the control solution with 0.30 mL of 0.01 mol/L hydrochloric acid VS (not more than 0.021%).

(3) Sulfate <1.14>—Perform the test with 0.6 g of L-Alanine. Prepare the control solution with 0.35 mL of 0.005 mol/L sulfuric acid VS (not more than 0.028%).

(4) Ammonium <1.02>—Perform the test with 0.25 g of

L-Alanine. Prepare the control solution with 5.0 mL of Standard Ammonium Solution (not more than 0.02%).

(5) Heavy metals <1.07>—Proceed with 1.0 g of L-Alanine according to Method 1, and perform the test. Prepare the control solution with 1.0 mL of Standard Lead Solution (not more than 10 ppm).

(6) Iron <1.10>—Prepare the test solution with 1.0 g of L-Alanine according to Method 1, and perform the test according to Method A. Prepare the control solution with 1.0 mL of Standard Iron Solution (not more than 10 ppm).

(7) Related substances—Weigh accurately about 0.5 g of L-Alanine, dissolve in 0.5 mL of hydrochloric acid and water to make exactly 100 mL. Pipet 10 mL of this solution, add 0.02 mol/L hydrochloric acid TS to make exactly 50 mL, and use this solution as the sample solution. Separately, accurately measure 2.5 mmol amounts of L-aspartic acid, L-threonine, L-serine, L-glutamic acid, glycine, L-alanine, L-cystine, L-valine, L-methionine, L-isoleucine, L-leucine, L-tyrosine, L-phenylalanine, L-lysine hydrochloride, ammonium chloride, L-histidine and L-arginine, dissolve in 0.1 mol/L hydrochloric acid TS to make exactly 1000 mL, and use this solution as the standard stock solution. Pipet 5 mL of the standard stock solution, add 0.02 mol/L hydrochloric acid TS to make exactly 100 mL. Pipet 4 mL of this solution, add 0.02 mol/L hydrochloric acid TS to make exactly 50 mL, and use this solution as the standard solution. Perform the test with exactly 20 μ L each of the sample solution and standard solution as directed under Liquid Chromatography <2.01> according to the following conditions. Based on the peak heights obtained from the sample solution and standard solution, determine the mass of the amino acids other than alanine contained in 1 mL of the sample solution, and calculate the mass percent: the amount of each amino acid other than alanine is not more than 0.1%.

Operating conditions—

Detector: A visible spectrophotometer (wavelength: 570 nm).

Column: A stainless steel column 4.6 mm in inside diameter and 8 cm in length, packed with strongly acidic ion-exchange resin for liquid chromatography (Na type) composed with a sulfonated polystyrene copolymer (3 μ m in particle diameter).

Column temperature: A constant temperature of about 57°C.

Chemical reaction bath temperature: A constant temperature of about 130°C.

Reaction time: About 1 minute.

Mobile phase: Prepare mobile phases A, B, C, D and E according to the following table, and add 0.1 mL of capric acid to each mobile phase.

	Mobile phase A	Mobile phase B	Mobile phase C	Mobile phase D	Mobile phase E
Citric acid monohydrate	19.80 g	22.00 g	12.80 g	6.10 g	—
Trisodium citrate dihydrate	6.19 g	7.74 g	13.31 g	26.67 g	—
Sodium chloride	5.66 g	7.07 g	3.74 g	54.35 g	—
Sodium hydroxide	—	—	—	—	8.00 g
Ethanol (99.5)	130 mL	20 mL	4 mL	—	100 mL
Thiodiglycol	5 mL	5 mL	5 mL	—	—
Benzyl alcohol	—	—	—	5 mL	—
Lauromacrogol solution (1 in 4)	4 mL	4 mL	4 mL	4 mL	4 mL
Water	Appropriate amount	Appropriate amount	Appropriate amount	Appropriate amount	Appropriate amount
Total volume	1000 mL	1000 mL	1000 mL	1000 mL	1000 mL

Changing mobile phases: When the procedure is run with 20 μ L of the standard solution under the above operating conditions, switchover in sequence to mobile phases A, B, C, D and E so that aspartic acid, threonine, serine, glutamic acid, glycine, alanine, cystine, valine, methionine, isoleucine, leucine, tyrosine, phenylalanine, lysine, ammonia, histidine, and arginine are eluted in this order with the resolution between the peaks of isoleucine and leucine being not less than 1.2.

Reaction reagents: Dissolve 204 g of lithium acetate dihydrate in water, add 123 mL of acetic acid (100) and 401 mL of 1-methoxy-2-propanol, and water to make 1000 mL, introduce nitrogen for 10 minutes, and use this solution as solution (I). Separately, add 39 g of ninhydrin to 979 mL of 1-methoxy-2-propanol, introduce nitrogen for 5 minutes, add 81 mg of sodium borohydride, introduce nitrogen for 30 minutes, and use this solution as solution (II). To 1 volume of solution (I) add 1 volume of solution (II). Prepare before use.

Flow rate of mobile phase: 0.20 mL per minute.

Flow rate of reaction reagent: 0.24 mL per minute.

System suitability—

System performance: When the procedure is run with 20 μ L of the standard solution under the above operating conditions, the resolution between the peaks of glycine and alanine is not less than 1.2.

System repeatability: When the test is repeated 6 times with 20 μ L of the standard solution under the above operating conditions, the relative standard deviations of the peak height and retention time of each amino acid obtained from the standard solution are not more than 5.0% and not more than 1.0%, respectively.

Loss on drying <2.41> Not more than 0.3% (1 g, 105°C, 3 hours).

Residue on ignition <2.44> Not more than 0.1% (1 g).

Assay Weigh accurately about 90 mg of L-Alanine, previously dried, dissolve in 3 mL of formic acid, add 50 mL of acetic acid (100), and titrate <2.50> with 0.1 mol/L perchloric acid VS (potentiometric titration). Perform a blank determination in the same manner, and make any necessary correction.

Each mL of 0.1 mol/L perchloric acid VS
= 8.909 mg of C₃H₇NO₂

Containers and storage Containers—Tight containers.

Albumin Tannate

タンニン酸アルブミン

Albumin Tannate is a compound of tannic acid and a protein.

The label states the origin of the protein of Albumin Tannate.

Description Albumin Tannate occurs as a light brown powder. It is odorless, or has a faint, characteristic odor.

It is practically insoluble in water and in ethanol (95).

It dissolves in sodium hydroxide TS with turbidity.

Identification (1) To 0.1 g of Albumin Tannate add 10 mL of ethanol (95), and heat in a water bath for 3 minutes with shaking. After cooling, filter, and to 5 mL of the filtrate add 1 drop of iron (III) chloride TS: a blue-purple to bluish black color is produced. On standing, a bluish black precipitate is produced.

(2) To 0.1 g of Albumin Tannate add 5 mL of nitric acid: an orange-yellow color develops.

Purity (1) Acidity—Shake 1.0 g of Albumin Tannate with 50 mL of water for 5 minutes, and filter. To 25 mL of the filtrate add 1.0 mL of 0.1 mol/L sodium hydroxide VS and 2 drops of phenolphthalein TS: a red color develops.

(2) Fats—To 2.0 g of Albumin Tannate add 20 mL of petroleum benzene, shake vigorously for 15 minutes, and filter. Evaporate 10 mL of the filtrate on a water bath: the mass of the residue is not more than 50 mg.

Loss on drying <2.41> Not more than 6.0% (1 g, 105°C, 3 hours).

Residue on ignition <2.44> Not more than 1.0% (0.5 g).

Digestion test To 1.00 g of Albumin Tannate add 0.25 g of saccharated pepsin and 100 mL of water, shake well, and allow to stand for 20 minutes at 40 \pm 1°C in a water bath. Add 1.0 mL of dilute hydrochloric acid, shake, and allow to stand for 3 hours at 40 \pm 1°C. Cool rapidly to ordinary temperature, and filter. Wash the residue with three 10-mL portions of water, dry in a desiccator (silica gel) for 18 hours, and dry at 105°C for 5 hours: the mass of the residue is 0.50 to 0.58 g.

Containers and storage Containers—Tight containers.

Storage—Light-resistant.

Aldioxa

アルジオキサ

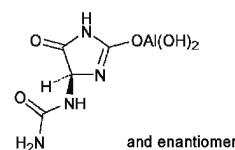

C₄H₇AlN₄O₅; 218.10

Dihydroxo[(4*RS*)-5-oxo-4-ureido-4,5-dihydro-1*H*-imidazol-2-yl]oxoaluminium
[5579-81-7]

Aldioxa is a condensation product of allantoin and aluminum hydroxide.

When dried, it contains not less than 65.3% and not

more than 74.3% of allantoin ($C_4H_6N_4O_3$: 158.12), and not less than 11.1% and not more than 13.0% of aluminum (Al: 26.98).

Description Aldioxa occurs as a white powder.

It is practically insoluble in water and in ethanol (99.5).

It dissolves in dilute hydrochloric acid.

A solution of Aldioxa in sodium fluoride-hydrochloric acid TS (1 in 100) shows no optical rotation.

Melting point: about 230°C (with decomposition).

Identification (1) Determine the infrared absorption spectrum of Aldioxa, previously dried, as directed in the potassium bromide disk method under Infrared Spectrophotometry <2.25>, and compare the spectrum with the Reference Spectrum: both spectra exhibit similar intensities of absorption at the same wave numbers.

(2) To 0.2 g of Aldioxa add 10 mL of dilute hydrochloric acid, dissolve by warming, and cool: the solution responds to Qualitative Tests <1.09> for aluminum salt.

Purity (1) Chloride <1.03>—To 0.10 g of Aldioxa add 6 mL of dilute nitric acid, boil to dissolve with shaking for 5 minutes, cool, and add water to make 50 mL. Perform the test using this solution as the test solution. Prepare the control solution with 0.40 mL of 0.01 mol/L hydrochloric acid VS (not more than 0.142%).

(2) Heavy metals <1.07>—To 1.0 g of Aldioxa add 3 mL of hydrochloric acid and 3 mL of water, heat gently to boil with shaking, and evaporate on a water bath to dryness. To the residue add 30 mL of water, shake under warming, cool, filter, and to the filtrate add 2 mL of dilute acetic acid and water to make 50 mL. Perform the test using this solution as the test solution. Prepare the control solution as follows: evaporate 3 mL of hydrochloric acid on a water bath to dryness, and add 2.0 mL of Standard Lead Solution, 2 mL of dilute acetic acid and water to make 50 mL (not more than 20 ppm).

Loss on drying <2.41> Not more than 4.0% (1 g, 105°C, 2 hours).

Assay (1) Allantoin—Weigh accurately about 0.1 g of Aldioxa, previously dried, dissolve in 50 mL of dilute sulfuric acid by heating, cool, and add water to make exactly 100 mL. Pipet 10 mL of this solution, and perform the test as directed under Nitrogen Determination <1.08>.

Each mL of 0.005 mol/L sulfuric acid VS
= 0.3953 mg of $C_4H_6N_4O_3$

(2) Aluminum—Weigh accurately about 0.2 g of Aldioxa, previously dried, dissolve carefully in 50 mL of dilute hydrochloric acid by heating, cool, and add dilute hydrochloric acid to make exactly 100 mL. Pipet 4 mL of this solution, add water to make exactly 25 mL, and use this solution as the sample solution. Separately, pipet a suitable quantity of Standard Aluminum Stock Solution, dilute with water so that each mL of the solution contains not less than 16.0 μ g and not more than 64.0 μ g of aluminum (Al: 26.98), and use this solution as the standard solution. Perform the test with the sample solution and standard solution as directed under Atomic Absorption Spectrophotometry <2.23> according to the following conditions, and calculate the aluminum content of the sample solution from the calibration curve obtained from the absorbance of the standard solution.

Gas: Combustible gas—Acetylene.

Supporting gas—Nitrous oxide.

Lamp: An aluminum hollow cathode lamp.

Wavelength: 309.2 nm.

Containers and storage Containers—Well-closed containers.

Aldioxa Granules

アルジオキサ顆粒

Aldioxa Granules contain not less than 95.0% and not more than 105.0% of the labeled amount of aldioxa ($C_4H_7AlN_4O_5$: 218.10).

Method of preparation Prepare as directed under Granules, with Aldioxa.

Identification (1) Determine the absorption spectrum of the sample solution obtained in the Assay as directed under Ultraviolet-visible Spectrophotometry <2.24>: it exhibits a maximum between 221 nm and 225 nm.

(2) To a quantity of powdered Aldioxa Granules, equivalent to 0.2 g of Aldioxa, add 10 mL of dilute hydrochloric acid, boil for 5 minutes, and filter: the cooled filtrate responds to Qualitative Tests <1.09> for aluminum salt.

Uniformity of dosage units <6.02> Perform the test according to the following method: Aldioxa Granules in single-dose packages meet the requirement of the Content uniformity test.

To the total content of 1 package of Aldioxa Granules add 80 mL of sodium fluoride-hydrochloric acid TS, shake for 20 minutes, add sodium fluoride-hydrochloric acid TS to make exactly 100 mL, and filter. Pipet V mL of the filtrate, add diluted ammonia-ammonium chloride buffer solution (pH 10.0) (1 in 10) to make exactly V' mL so that each mL contains about 20 μ g of aldioxa ($C_4H_7AlN_4O_5$), and use this solution as the sample solution. Then, proceed as directed in the Assay.

$$\begin{aligned} & \text{Amount (mg) of aldioxa (C}_4\text{H}_7\text{AlN}_4\text{O}_5\text{)} \\ & = M_S \times A_T/A_S \times V'/V \times 1/25 \end{aligned}$$

M_S : Amount (mg) of aldioxa for assay taken

Dissolution <6.10> When the test is performed at 50 revolutions per minute according to the Paddle method, using 900 mL of water as the dissolution medium, the dissolution rate in 15 minutes of Aldioxa Granules is not less than 85%.

Start the test with an accurately weighed amount of Aldioxa Granules, equivalent to about 0.1 g of aldioxa ($C_4H_7AlN_4O_5$), withdraw not less than 20 mL of the medium at the specified minute after starting the test, and filter through a membrane filter with a pore size not exceeding 0.45 μ m. Discard not less than 10 mL of the first filtrate, pipet 10 mL of the subsequent filtrate, add diluted ammonia-ammonium chloride buffer solution (pH 10.0) (1 in 10) to make exactly 50 mL, and use this solution as the sample solution. Separately, weigh accurately about 28 mg of aldioxa for assay, previously dried at 105°C for 2 hours, and dissolve in sodium fluoride-hydrochloric acid TS to make exactly 25 mL. Pipet 1 mL of this solution, add diluted ammonia-ammonium chloride buffer solution (pH 10.0) (1 in 10) to make exactly 50 mL, and use this solution as the standard solution. Determine the absorbances, A_T and A_S , at 223 nm of the sample solution and standard solution as directed under Ultraviolet-visible Spectrophotometry <2.24>.

Dissolution rate (%) with respect to the labeled amount of aldioxa ($C_4H_7AlN_4O_5$)

$$= M_S/M_T \times A_T/A_S \times 1/C \times 360$$

M_S : Amount (mg) of aldioxa for assay taken

M_T : Amount (g) of Aldioxa Granules taken

C : Labeled amount (mg) of aldioxa ($C_4H_7AlN_4O_5$) in 1 g

Assay Weigh accurately an amount of powdered Aldioxa Granules, equivalent to about 0.1 g of aldioxa ($C_4H_7AlN_4O_5$), add 80 mL of sodium fluoride-hydrochloric acid TS, shake for 20 minutes, add sodium fluoride-hydrochloric acid TS to make exactly 100 mL, and filter. Pipet 2 mL of the filtrate, add diluted ammonia-ammonium chloride buffer solution (pH 10.0) (1 in 10) to make exactly 100 mL, and use this solution as the sample solution. Separately, weigh accurately about 50 mg of aldioxa for assay, previously dried at 105°C for 2 hours, and dissolve in sodium fluoride-hydrochloric acid TS to make exactly 100 mL. Pipet 4 mL of this solution, add diluted ammonia-ammonium chloride buffer solution (pH 10.0) (1 in 10) to make exactly 100 mL, and use this solution as the standard solution. Determine the absorbances, A_T and A_S , at 223 nm of the sample solution and standard solution as directed under Ultraviolet-visible Spectrophotometry <2.24>.

$$\begin{aligned} &\text{Amount (mg) of aldioxa (C}_4\text{H}_7\text{AlN}_4\text{O}_5\text{)} \\ &= M_S \times A_T/A_S \times 2 \end{aligned}$$

M_S : Amount (mg) of aldioxa for assay taken

Containers and storage Containers—Tight containers.

Aldioxa Tablets

アルジオキサ錠

Aldioxa Tablets contain not less than 95.0% and not more than 105.0% of the labeled amount of aldioxa ($C_4H_7AlN_4O_5$; 218.10).

Method of preparation Prepare as directed under Tablets, with Aldioxa.

Identification Determine the absorption spectrum of the sample solution obtained in the Assay as directed under Ultraviolet-visible Spectrophotometry <2.24>: it exhibits a maximum between 221 nm and 225 nm.

Uniformity of dosage units <6.02> Perform the Mass variation test, or the Content uniformity test according to the following method: it meets the requirement.

To 1 tablet of Aldioxa Tablets add 80 mL of sodium fluoride-hydrochloric acid TS, shake for 20 minutes, add sodium fluoride-hydrochloric acid TS to make exactly 100 mL, and filter. Pipet V mL of the filtrate, add diluted ammonia-ammonium chloride buffer solution (pH 10.0) (1 in 10) to make exactly V' mL so that each mL contains about 20 μ g of aldioxa ($C_4H_7AlN_4O_5$), and use this solution as the sample solution. Then, proceed as directed in the Assay.

$$\begin{aligned} &\text{Amount (mg) of aldioxa (C}_4\text{H}_7\text{AlN}_4\text{O}_5\text{)} \\ &= M_S \times A_T/A_S \times V'/V \times 1/25 \end{aligned}$$

M_S : Amount (mg) of aldioxa for assay taken

Dissolution <6.10> When the test is performed at 50 revolutions per minute according to the Paddle method, using 900 mL of water as the dissolution medium, the dissolution rates in 15 minutes of 50-mg tablet and in 30 minutes of 100-mg tablet are not less than 80% and not less than 70%, respec-

tively.

Start the test with 1 tablet of Aldioxa Tablets, withdraw not less than 20 mL of the medium at the specified minute after starting the test, and filter through a membrane filter with a pore size not exceeding 0.45 μ m. Discard not less than 10 mL of the first filtrate, pipet V mL of the subsequent filtrate, add diluted ammonia-ammonium chloride buffer solution (pH 10.0) (1 in 10) to make exactly V' mL so that each mL contains about 22 μ g of aldioxa ($C_4H_7AlN_4O_5$), and use this solution as the sample solution. Separately, weigh accurately about 28 mg of aldioxa for assay, previously dried at 105°C for 2 hours, and dissolve in sodium fluoride-hydrochloric acid TS to make exactly 25 mL. Pipet 1 mL of this solution, add diluted ammonia-ammonium chloride buffer solution (pH 10.0) (1 in 10) to make exactly 50 mL, and use this solution as the standard solution. Determine the absorbances, A_T and A_S , at 223 nm of the sample solution and standard solution as directed under Ultraviolet-visible Spectrophotometry <2.24>.

Dissolution rate (%) with respect to the labeled amount of aldioxa ($C_4H_7AlN_4O_5$)

$$= M_S \times A_T/A_S \times V'/V \times 1/C \times 72$$

M_S : Amount (mg) of aldioxa for assay taken

C : Labeled amount (mg) of aldioxa ($C_4H_7AlN_4O_5$) in 1 tablet

Assay Weigh accurately, and powder not less than 20 Aldioxa Tablets. Weigh accurately a portion of the powder, equivalent to about 0.1 g of aldioxa ($C_4H_7AlN_4O_5$), add 80 mL of sodium fluoride-hydrochloric acid TS, shake for 20 minutes, add sodium fluoride-hydrochloric acid TS to make exactly 100 mL, and filter. Pipet 2 mL of the filtrate, add diluted ammonia-ammonium chloride buffer solution (pH 10.0) (1 in 10) to make exactly 100 mL, and use this solution as the sample solution. Separately, weigh accurately about 50 mg of aldioxa for assay, previously dried at 105°C for 2 hours, and dissolve in sodium fluoride-hydrochloric acid TS to make exactly 100 mL. Pipet 4 mL of this solution, add diluted ammonia-ammonium chloride buffer solution (pH 10.0) (1 in 10) to make exactly 100 mL, and use this solution as the standard solution. Determine the absorbances, A_T and A_S , at 223 nm of the sample solution and standard solution as directed under Ultraviolet-visible Spectrophotometry <2.24>.

$$\begin{aligned} &\text{Amount (mg) of aldioxa (C}_4\text{H}_7\text{AlN}_4\text{O}_5\text{)} \\ &= M_S \times A_T/A_S \times 2 \end{aligned}$$

M_S : Amount (mg) of aldioxa for assay taken

Containers and storage Containers—Tight containers.

Alendronate Sodium Hydrate

アレンドロン酸ナトリウム水和物

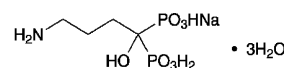

$C_4H_{12}NNaO_7P_2 \cdot 3H_2O$: 325.12

Monosodium trihydrogen 4-amino-1-hydroxybutane-1,1-diylidiphosphonate trihydrate

[121268-17-5]

Alendronate Sodium Hydrate contains not less than 99.0% and not more than 101.0% of alendronate sodium ($C_4H_{12}NNaO_7P_2$; 271.08), calculated on the dried

basis.

Description Alendronate Sodium Hydrate occurs as a white crystalline powder.

It is sparingly soluble in water, and practically insoluble in ethanol (99.5).

It dissolves in 0.1 mol/L trisodium citrate TS.

Melting point: about 252°C (with decomposition, after drying).

Identification (1) To 5 mL of a solution of Alendronate Sodium Hydrate (1 in 50) add 1 mL of ninhydrin TS, and heat: a blue-purple color develops.

(2) Determine the infrared absorption spectrum of Alendronate Sodium Hydrate as directed in the potassium bromide disk method under Infrared Spectrophotometry <2.25>, and compare the spectrum with the Reference Spectrum or the spectrum of Alendronate Sodium RS: both spectra exhibit similar intensities of absorption at the same wave numbers.

(3) To 0.1 g of Alendronate Sodium Hydrate add 10 mL of a mixture of nitric acid and perchloric acid (1:1). Heat to concentrate to about 1 mL, add about 10 mL of water while hot, and neutralize with a solution of sodium hydroxide (2 in 5): the solution responds to Qualitative Tests <1.09> for phosphate.

(4) A solution of Alendronate Sodium Hydrate (1 in 100) responds to Qualitative Tests <1.09> for sodium salt.

pH <2.54> The pH of a solution of 1.0 g of Alendronate Sodium Hydrate in 100 mL of freshly boiled and cooled water is between 4.0 and 5.0.

Purity (1) Heavy metals <1.07>—Put 1.0 g of Alendronate Sodium Hydrate in a Kjeldahl flask, add 9 mL of a mixture of nitric acid and sulfuric acid (5:4), and heat until the solution becomes brown. After cooling, add 9 mL of a mixture of nitric acid and sulfuric acid (5:4), and heat again until the color changes from colorless to brown. After cooling, add 2 mL of nitric acid, strongly heat until brown fumes are no longer evolved, and heat until large amounts of white fumes are evolved. After cooling, add carefully 5 mL of water and 1 mL of hydrogen peroxide (30), heat until white fumes are no longer evolved, and continue heating for more 5 minutes. After cooling, if any yellow color remains, add 2 mL of nitric acid, and repeat the same procedure. After cooling, transfer the solution in the Kjeldahl flask to a beaker, wash out the inside of the flask with 5 mL of water, and add the washing to the beaker. Adjust to pH 3–5 with ammonia solution (28), transfer to a Nessler tube, add water to make 50 mL, and perform the test with this solution as the test solution. Prepare the control solution in the same procedure using the same amount of the reagents used for the preparation of the sample solution, add 1.0 mL of Standard Lead Solution and add water to make 50 mL (not more than 10 ppm).

(2) Related substances—Dissolve 15 mg of Alendronate Sodium Hydrate in 25 mL of 0.1 mol/L trisodium citrate TS, and use this solution as the sample stock solution. Pipet 5 mL of the sample stock solution, and add 0.1 mol/L trisodium citrate TS to make exactly 50 mL. Pipet 1 mL of this solution, add 0.1 mol/L trisodium citrate TS to make exactly 100 mL, and use this solution as the standard stock solution. To exactly 5 mL each of the sample stock solution and standard stock solution, add exactly 5 mL each of a solution of sodium tetraborate decahydrate (19 in 1000), acetonitrile and a solution of 9-fluorenylmethyl chloroformate in acetonitrile (1 in 250), shake for 45 seconds, and allow to stand for 30 minutes at room temperature. Then, add 20 mL of

dichloromethane to them, shake for 60 seconds, centrifuge, and use the supernatant liquids so obtained as the sample solution and the standard solution, respectively. Perform the test with exactly 20 μ L each of the sample solution and standard solution as directed under Liquid Chromatography <2.01> according to the following conditions. Determine each peak area of these solutions by the automatic integration method: each peak area other than alendronic acid obtained from the sample solution is not larger than the peak area of alendronic acid from the standard solution.

Operating conditions—

Detector: An ultraviolet absorption photometer (wavelength: 266 nm).

Column: A stainless steel column 4.1 mm in inside diameter and 25 cm in length, packed with styrene-divinylbenzene copolymer for liquid chromatography (10 μ m in particle diameter).

Column temperature: A constant temperature of about 45°C.

Mobile phase A: Dissolve 2.94 g of trisodium citrate dihydrate and 1.42 g of anhydrous disodium hydrogen phosphate in 900 mL of water, adjust to pH 8.0 with phosphoric acid, and add water to make 1000 mL. To 850 mL of this solution add 150 mL of acetonitrile for liquid chromatography.

Mobile phase B: Dissolve 2.94 g of trisodium citrate dihydrate and 1.42 g of anhydrous disodium hydrogen phosphate in 900 mL of water, adjust to pH 8.0 with phosphoric acid, and add water to make 1000 mL. To 300 mL of this solution add 700 mL of acetonitrile for liquid chromatography.

Flowing of mobile phase: Control the gradient by mixing the mobile phases A and B as directed in the following table.

Time after injection of sample (min)	Mobile phase A (vol%)	Mobile phase B (vol%)
0 – 15	100 → 50	0 → 50
15 – 25	50 → 0	50 → 100

Flow rate: About 1.8 mL per minute.

Time span of measurement: About 5 times as long as the retention time of alendronic acid, beginning after the solvent peak.

System suitability—

System performance: Dissolve 15 mg of Alendronate Sodium Hydrate and 2 mg of 4-aminobutylic acid in 100 mL of 0.1 mol/L trisodium citrate TS. To 5 mL of this solution add 5 mL each of a solution of sodium tetraborate decahydrate (19 in 1000), acetonitrile and a solution of 9-fluorenylmethyl chloroformate in acetonitrile (1 in 250), then, proceed in the same manner as the sample solution. When the procedure is run with 20 μ L of this solution under the above operating conditions, alendronic acid and 4-aminobutylic acid are eluted in this order with the resolution between these peaks being not less than 6.

System repeatability: When the test is repeated 6 times with 20 μ L of the standard solution under the above operating conditions, the relative standard deviation of the peak area of alendronic acid is not more than 2.0%.

Loss on drying <2.41> 16.1 – 17.1% (1 g, 140°C, 3 hours).

Assay Weigh accurately about 10 mg each of Alendronate Sodium Hydrate and Alendronate Sodium RS (separately determine the loss on drying <2.41> in the same conditions as Alendronate Sodium Hydrate), dissolve in 0.1 mol/L trisodium citrate TS to make exactly 100 mL, and use these solutions as the sample stock solution and the standard stock so-

lution, respectively. To exactly 5 mL each of these solutions add exactly 5 mL each of a solution of sodium tetraborate decahydrate (19 in 1000) and a solution of 9-fluorenylmethyl chloroformate in acetonitrile (1 in 2000), shake for 30 seconds, and allow to stand for 25 minutes. Then, add 25 mL of dichloromethane, shake for 60 seconds, centrifuge, and use the supernatant liquids so obtained as the sample solution and the standard solution, respectively. Perform the test with exactly 10 μ L each of the sample solution and standard solution as directed under Liquid Chromatography <2.01> according to the following conditions, and determine the peak areas, A_T and A_S , of alendronic acid in each solution.

$$\begin{aligned} &\text{Amount (mg) of alendronate sodium (C}_4\text{H}_{12}\text{NNaO}_7\text{P}_2) \\ &= M_S \times A_T/A_S \end{aligned}$$

M_S : Amount (mg) of Alendronate Sodium RS taken, calculated on the dried basis

Operating conditions—

Detector: An ultraviolet absorption photometer (wavelength: 266 nm).

Column: A stainless steel column 4.1 mm in inside diameter and 25 cm in length, packed with styrene-divinylbenzene copolymer for liquid chromatography (10 μ m in particle diameter).

Column temperature: A constant temperature of about 35°C.

Mobile phase: Dissolve 14.7 g of trisodium citrate dihydrate and 7.1 g of anhydrous disodium hydrogen phosphate in 900 mL of water, adjust to pH 8.0 with phosphoric acid, and add water to make 1000 mL. To 700 mL of this solution add 250 mL of acetonitrile for liquid chromatography and 50 mL of methanol.

Flow rate: Adjust so that the retention time of alendronic acid is about 3 minutes.

System suitability—

System performance: When the procedure is run with 10 μ L of the standard solution under the above operating conditions, the number of theoretical plates and the symmetry factor of the peak of alendronic acid are not less than 1500 and not more than 1.5, respectively.

System repeatability: When the test is repeated 6 times with 10 μ L of the standard solution under the above operating conditions, the relative standard deviation of the peak area of alendronic acid is not more than 1.0%.

Containers and storage Containers—Tight containers.

Alendronate Sodium Injection

アレンドロン酸ナトリウム注射液

Alendronate Sodium Injection is an aqueous injection.

It contains not less than 95.0% and not more than 105.0% of the labeled amount of alendronic acid (C₄H₁₃NO₇P₂; 249.10).

Method of preparation Prepare as directed under Injections, with Alendronate Sodium Hydrate.

Description Alendronate Sodium Injection is a clear, colorless liquid.

Identification Use Alendronate Sodium Injection as the sample solution. Separately, dissolve 33 mg of alendronate sodium hydrate in 10 mL of water, and use this solution as

the standard solution. Perform the test with these solutions as directed under Thin-layer Chromatography <2.03>. Spot 5 μ L each of the sample solution and standard solution on a plate of cellulose for thin-layer chromatography. Develop the plate with a mixture of water, pyridine, acetic acid (100) and ethyl acetate (1:1:1:1) to a distance of about 10 cm, and air-dry the plate. Spray evenly a solution of ninhydrin in acetone (1 in 50) on the plate, and heat at 100°C for 10 minutes: the principal spots from the sample solution and standard solution show a blue-purple color and the same R_f value.

pH Being specified separately when the drug is granted approval based on the Law.

Bacterial endotoxins <4.01> Less than 119 EU/mg.

Extractable volume <6.05> It meets the requirement.

Foreign insoluble matter <6.06> Perform the test according to Method 1: it meets the requirement.

Insoluble particulate matter <6.07> It meets the requirement.

Sterility <4.06> Perform the test according to Membrane-filter method: it meets the requirement.

Assay To an exactly measured volume of Alendronate Sodium Injection, equivalent to about 5 mg of alendronic acid (C₄H₁₃NO₇P₂), add a solution of disodium dihydrogen ethylenediamine tetraacetate dihydrate (1 in 500) to make exactly 100 mL, and use this solution as the sample stock solution. Separately, weigh accurately about 33 mg of Alendronate Sodium RS (separately determine the loss on drying <2.41> under the same conditions as Alendronate Sodium Hydrate), and dissolve in a solution of disodium dihydrogen ethylenediamine tetraacetate dihydrate (1 in 500) to make exactly 100 mL. Pipet 10 mL of this solution, add a solution of disodium dihydrogen ethylenediamine tetraacetate dihydrate (1 in 500) to make exactly 50 mL, and use this solution as the standard stock solution. Pipet 5 mL each of the sample stock solution and standard stock solution, add exactly 5 mL of a solution of sodium tetraborate decahydrate (19 in 500) and exactly 4 mL of a solution of 9-fluorenylmethyl chloroformate in acetonitrile (1 in 1000), shake for 30 seconds, and allow to stand at room temperature for 25 minutes. Then, add 25 mL of dichloromethane to them, shake for 45 seconds, centrifuge, and use the supernatant liquid so obtained as the sample solution and the standard solution, respectively. Perform the test with 50 μ L each of the sample solution and standard solution as directed under Liquid Chromatography <2.01> according to the following conditions, and determine the peak areas, A_T and A_S , of alendronic acid in each solution.

$$\begin{aligned} &\text{Amount (mg) of alendronic acid (C}_4\text{H}_{13}\text{NO}_7\text{P}_2) \\ &= M_S \times A_T/A_S \times 1/5 \times 0.919 \end{aligned}$$

M_S : Amount (mg) of Alendronate Sodium RS taken, calculated on the dried basis

Operating conditions—

Detector: An ultraviolet absorption photometer (wavelength: 265 nm).

Column: A stainless steel column 4.1 mm in inside diameter and 25 cm in length, packed with styrene-divinylbenzene copolymer for liquid chromatography (10 μ m in particle diameter).

Column temperature: A constant temperature of about 40°C.

Mobile phase: Dissolve 14.7 g of trisodium citrate dihydrate and 8.7 g of dipotassium hydrogen phosphate in 900

mL of water, adjust to pH 8.0 with phosphoric acid, and add water to make 1000 mL. To 750 mL of this solution add 200 mL of acetonitrile for liquid chromatography and 50 mL of methanol.

Flow rate: Adjust so that the retention time of alendronic acid is about 7 minutes.

System suitability—

System performance: When the procedure is run with 50 μ L of the standard solution under the above operating conditions, the number of theoretical plates and the symmetry factor of the peak of alendronic acid are not less than 1500 and not more than 1.5, respectively.

System repeatability: When the test is repeated 6 times with 50 μ L of the standard solution under the above operations conditions, the relative standard deviation of the peak of alendronic acid is not more than 1.0%.

Containers and storage Containers—Hermetic containers.

Alendronate Sodium Tablets

アレンドロン酸ナトリウム錠

Alendronate Sodium Tablets contain not less than 95.0% and not more than 105.0% of the labeled amount of alendronic acid ($C_4H_{13}NO_7P_2$: 249.10).

Method of preparation Prepare as directed under Tablets, with Alendronate Sodium Hydrate.

Identification To a quantity of powdered Alendronate Sodium Tablets, equivalent to 25 mg of alendronic acid ($C_4H_{13}NO_7P_2$), add 25 mL of water, shake, centrifuge, and use the supernatant liquid as the sample solution. Separately, weigh 33 mg of alendronate sodium hydrate, and dissolve in 25 mL of water, and use this solution as the standard solution. Perform the test with these solutions as directed under Thin-layer Chromatography <2.03>. Spot 5 μ L each of the sample solution and standard solution on a plate of cellulose for thin-layer chromatography. Develop the plate with a mixture of water, pyridine, acetic acid (100) and ethyl acetate (1:1:1:1) to a distance of about 10 cm, and air-dry the plate. Spray evenly a solution of ninhydrin in acetone (1 in 50) on the plate, and heat the plate at 100°C for 10 minutes: the principal spots from the sample solution and standard solution show a blue-purple color and the same *R_f* value.

Uniformity of dosage units <6.02> Perform the Mass variation test, or the Content uniformity test according to the following method: it meets the requirement.

To 1 tablet of Alendronate Sodium Tablets add 0.1 mol/L trisodium citrate TS to make exactly 100 mL, and stir until the tablet is completely disintegrated. Centrifuge this solution, pipet *V* mL of the supernatant liquid, and add 0.1 mol/L trisodium citrate TS to make exactly *V'* mL so that each mL contains about 25 μ g of alendronic acid ($C_4H_{13}NO_7P_2$), and use this solution as the sample stock solution. Then, proceed as directed in the Assay.

$$\begin{aligned} &\text{Amount (mg) of alendronic acid (C}_4\text{H}_{13}\text{NO}_7\text{P}_2\text{)} \\ &= M_S \times A_T/A_S \times V'/V \times 2/25 \times 0.919 \end{aligned}$$

M_S: Amount (mg) of Alendronate Sodium RS taken, calculated on the dried basis

Dissolution <6.10> When the test is performed at 50 revolutions per minute according to the Paddle method, using 900 mL of water as the dissolution medium, the dissolution rate in 15 minutes of Alendronate Sodium Tablets is not less than

85%.

Start the test with 1 tablet of Alendronate Sodium Tablets, withdraw not less than 10 mL of the medium at the specified minute after starting the test, and centrifuge. Pipet *V* mL of the supernatant liquid, add water to make exactly *V'* mL so that each mL contains about 6 μ g of alendronic acid ($C_4H_{13}NO_7P_2$), and use this solution as the sample stock solution. Separately, weigh accurately about 29 mg of Alendronate Sodium RS (separately determine the loss on drying <2.41> under the same conditions as Alendronate Sodium Hydrate), and dissolve in water to make exactly 250 mL. Pipet 3 mL of this solution, add water to make exactly 50 mL, and use this solution as the standard stock solution. Pipet 5 mL each of the sample stock solution and standard stock solution, add exactly 1 mL of trisodium citrate dihydrate solution (22 in 125), exactly 5 mL of a solution obtained by dissolving 6.2 g of boric acid in 950 mL of water, adjusting to pH 9.0 with sodium hydrate TS, and adding water to make 1000 mL, and add exactly 4 mL of a solution of 9-fluorenylmethyl chloroformate in acetonitrile (1 in 2000), shake for 30 seconds, and allow to stand at room temperature for 25 minutes. Add 25 mL of dichloromethane, shake for 45 seconds, then centrifuge, and use the supernatant liquid as the sample solution and the standard solution, respectively. Then, proceed as directed in the Assay.

$$\begin{aligned} &\text{Dissolution rate (\%)} \text{ with respect to the labeled amount} \\ &\text{of alendronic acid (C}_4\text{H}_{13}\text{NO}_7\text{P}_2\text{)} \\ &= M_S \times A_T/A_S \times V'/V \times 1/C \times 108/5 \times 0.919 \end{aligned}$$

M_S: Amount (mg) of Alendronate Sodium RS taken, calculated on the dried basis

C: Labeled amount (mg) of alendronic acid ($C_4H_{13}NO_7P_2$) in 1 tablet

Assay Weigh accurately and powder not less than 20 Alendronate Sodium Tablets. Weigh accurately a portion of the powder, equivalent to about 50 mg of alendronic acid ($C_4H_{13}NO_7P_2$), add 0.1 mol/L trisodium citrate TS to make exactly 1000 mL, stir for 30 minutes, and centrifuge. Pipet 5 mL of the supernatant liquid, add 0.1 mol/L trisodium citrate TS to make exactly 10 mL, and use this solution as the sample stock solution. Separately, weigh accurately about 39 mg of Alendronate Sodium RS (separately determine the loss on drying <2.41> under the same conditions as Alendronate Sodium Hydrate), dissolve in 0.1 mol/L trisodium citrate TS to make exactly 50 mL. Pipet 2 mL of this solution, add 0.1 mol/L trisodium citrate TS to make exactly 50 mL, and use this solution as the standard stock solution. Pipet 5 mL each of the sample stock solution and standard stock solution, add exactly 5 mL of a solution of sodium tetraborate decahydrate (19 in 500) and exactly 4 mL of a solution of 9-fluorenylmethyl chloroformate in acetonitrile (1 in 1000), shake for 30 seconds, and allow to stand at room temperature for 25 minutes. Then, add 25 mL of dichloromethane to them, shake for 45 seconds, centrifuge, and use the supernatant liquid so obtained as the sample solution and the standard solution, respectively. Perform the test with exactly 50 μ L each of the sample solution and standard solution as directed under Liquid Chromatography <2.01> according to the following conditions, and determine the peak areas, *A_T* and *A_S*, of alendronic acid in each solution.

$$\begin{aligned} &\text{Amount (mg) of alendronic acid (C}_4\text{H}_{13}\text{NO}_7\text{P}_2\text{)} \\ &= M_S \times A_T/A_S \times 8/5 \times 0.919 \end{aligned}$$

M_S: Amount (mg) of Alendronate Sodium RS taken, calculated on the dried basis

Operating conditions—

Detector: An ultraviolet absorption photometer (wavelength: 266 nm).

Column: A stainless steel column 4.1 mm in inside diameter and 25 cm in length, packed with styrene-divinylbenzene copolymer for liquid chromatography (10 μ m in particle diameter).

Column temperature: A constant temperature of about 35°C.

Mobile phase: Dissolve 14.7 g of trisodium citrate dihydrate and 7.1 g of anhydrous disodium hydrogen phosphate in 900 mL of water, adjust to pH 8.0 with phosphoric acid, and add water to make 1000 mL. To 750 mL of this solution add 200 mL of acetonitrile for liquid chromatography and 50 mL of methanol.

Flow rate: Adjust so that the retention time of alendronic acid is about 7 minutes.

System suitability—

System performance: When the procedure is run with 50 μ L of the standard solution under the above operating conditions, the number of theoretical plates and the symmetry factor of the peak of alendronic acid are not less than 1500 and not more than 1.5, respectively.

System repeatability: When the test is repeated 6 times with 50 μ L of the standard solution under the above operations conditions, the relative standard deviation of the peak of alendronic acid is not more than 1.0%.

Containers and storage Containers—Well-closed containers.

Alimemazine Tartrate

アリメマジン酒石酸塩

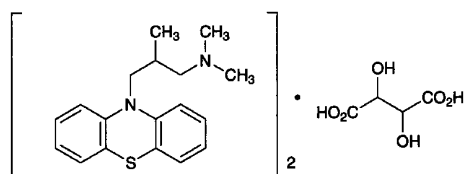

(C₁₈H₂₂N₂S)₂·C₄H₆O₆; 746.98
N,N,2-Trimethyl-3-(10*H*-phenothiazin-10-yl)propylamine hemitartrate
 [41375-66-0]

Alimemazine Tartrate, when dried, contains not less than 98.0% of alimemazine tartrate [(C₁₈H₂₂N₂S)₂·C₄H₆O₆].

Description Alimemazine Tartrate occurs as a white powder. It is odorless, and has a bitter taste.

It is freely soluble in water and in acetic acid (100), sparingly soluble in ethanol (95), and practically insoluble in diethyl ether.

The pH of a solution of 1.0 g of Alimemazine Tartrate in 50 mL of water is between 5.0 and 6.5.

It is gradually colored by light.

Identification (1) To 2 mL of a solution of Alimemazine Tartrate (1 in 100) add 1 drop of iron (III) chloride TS: a red-brown color is produced, and immediately a yellow precipitate is formed.

(2) Dissolve 1 g of Alimemazine Tartrate in 5 mL of water, add 3 mL of sodium hydroxide TS, extract with two 10-mL portions of diethyl ether [use the aqueous layer obtained in the Identification (4)]. Shake the combined diethyl

ether extracts with 3 g of anhydrous sodium sulfate, filter, and evaporate the diethyl ether with the aid of a current of air. Dry the residue in a desiccator (in vacuum, phosphorus (V) oxide) for 16 hours: it melts <2.60> between 66°C and 70°C.

(3) Determine the absorption spectrum of a solution of Alimemazine Tartrate (1 in 100,000) as directed under Ultraviolet-visible Spectrophotometry <2.24>, and compare the spectrum with the Reference Spectrum: both spectra exhibit similar intensities of absorption at the same wavelengths.

(4) The aqueous layer, obtained in the identification (2), when neutralized with dilute acetic acid, responds to Qualitative Tests <1.09> (1) and (2) for tartrate.

Melting point <2.60> 159 – 163°C

Purity (1) Clarity and color of solution—Dissolve 1.0 g of Alimemazine Tartrate in 20 mL of water: the solution is clear and colorless.

(2) Heavy metals <1.07>—Proceed with 1.0 g of Alimemazine Tartrate according to Method 2, and perform the test. Prepare the control solution with 2.0 mL of Standard Lead Solution (not more than 20 ppm).

(3) Arsenic <1.11>—Prepare the test solution with 1.0 g of Alimemazine Tartrate according to Method 3, and perform the test. Use a solution of magnesium nitrate hexahydrate in ethanol (95) (1 in 5) (not more than 2 ppm).

Loss on drying <2.41> Not more than 0.5% (1 g, 105°C, 3 hours).

Residue on ignition <2.44> Not more than 0.1% (1 g).

Assay Weigh accurately about 0.8 g of Alimemazine Tartrate, previously dried, dissolve in 50 mL of acetic acid (100), and titrate <2.50> with 0.1 mol/L perchloric acid VS until the color of the solution changes from red through brown to green-brown (indicator: 2 mL of *p*-naphtholbenzein TS). Perform a blank determination in the same manner, and make any necessary correction.

Each mL of 0.1 mol/L perchloric acid VS
 = 37.35 mg of (C₁₈H₂₂N₂S)₂·C₄H₆O₆

Containers and storage Containers—Tight containers.
 Storage—Light-resistant.

Allopurinol

アロプリノール

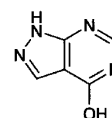

C₅H₄N₄O: 136.11
 1*H*-Pyrazolo[3,4-*d*]pyrimidin-4-ol
 [315-30-0]

Allopurinol, when dried, contains not less than 98.0% and not more than 101.0% of allopurinol (C₅H₄N₄O).

Description Allopurinol occurs as white to pale yellow-white, crystals or crystalline powder.

It is slightly soluble in *N,N*-dimethylformamide, and very slightly soluble in water and in ethanol (99.5).

It dissolves in ammonia TS.

Identification (1) Determine the absorption spectrum of a

solution of Allopurinol (1 in 200,000) as directed under Ultraviolet-visible Spectrophotometry <2.24>, and compare the spectrum with the Reference Spectrum: both spectra exhibit similar intensities of absorption at the same wavelengths.

(2) Determine the infrared absorption spectrum of Allopurinol, previously dried, as directed in the potassium bromide disk method under Infrared Spectrophotometry <2.25>, and compare the spectrum with the Reference Spectrum: both spectra exhibit similar intensities of absorption at the same wave numbers.

Purity (1) Heavy metals <1.07>—Proceed with 1.0 g of Allopurinol according to Method 2, and perform the test. Prepare the control solution with 2.0 mL of Standard Lead Solution (not more than 20 ppm).

(2) Arsenic <1.11>—Prepare the test solution with 1.0 g of Allopurinol according to Method 3, and perform the test (not more than 2 ppm).

(3) Related substances—Dissolve 50 mg of Allopurinol in 10 mL of ammonia TS, and use this solution as the sample solution. Pipet 1 mL of the sample solution, add ammonia TS to make exactly 500 mL, and use this solution as the standard solution. Perform the test with these solutions as directed under Thin-layer Chromatography <2.03>. Spot 5 μL each of the sample solution and standard solution on a plate of cellulose with fluorescent indicator for thin-layer chromatography. Develop the plate with ammonia TS-saturated 1-butanol to a distance of about 10 cm, and air-dry the plate. Examine under ultraviolet light (main wavelength: 254 nm): the spots other than the principal spot obtained from the sample solution are not more intense than the spot from the standard solution.

Loss on drying <2.41> Not more than 0.5% (1 g, 105°C, 4 hours).

Residue on ignition <2.44> Not more than 0.1% (1 g).

Assay Weigh accurately about 0.16 g of Allopurinol, previously dried, dissolve in 70 mL of *N,N*-dimethylformamide by warming. Cool, and titrate <2.50> with 0.1 mol/L tetramethylammonium hydroxide VS (potentiometric titration). To 70 mL of *N,N*-dimethylformamide add 12 mL of water, perform a blank determination in the same manner, and make any necessary correction.

Each mL of 0.1 mol/L tetramethylammonium hydroxide VS
= 13.61 mg of $\text{C}_5\text{H}_4\text{N}_4\text{O}$

Containers and storage Containers—Tight containers.

Allopurinol Tablets

アロプリノール錠

Allopurinol Tablets contain not less than 93.0% and not more than 107.0% of the labeled amount of allopurinol ($\text{C}_5\text{H}_4\text{N}_4\text{O}$: 136.11).

Method of preparation Prepare as directed under Tablets, with Allopurinol.

Identification (1) Determine the absorption spectrum of the sample solution obtained in the Assay as directed under Ultraviolet-visible Spectrophotometry <2.24>: it exhibits a maximum between 248 nm and 252 nm.

(2) To a quantity of powdered Allopurinol Tablets, equivalent to 0.1 g of Allopurinol, add 5 mL of a solution of

diethylamine (1 in 10), shake well, add 5 mL of methanol, centrifuge, and use the supernatant liquid as the sample solution. Separately, dissolve 0.1 g of allopurinol in 5 mL of a solution of diethylamine (1 in 10), add 5 mL of methanol, and use this solution as the standard solution. Perform the test with these solutions as directed under Thin-layer Chromatography <2.03>. Spot 2.5 μL each of the sample solution and standard solution on a plate of silica gel with fluorescent indicator for thin-layer chromatography. Develop the plate with a mixture of 2-butanone, ammonia solution (28) and 2-methoxyethanol (3:1:1) to a distance of about 10 cm, and air-dry the plate. Examine under ultraviolet light (main wavelength: 254 nm): the principal spots obtained from the sample solution and standard solution show the same *R_f* value.

Uniformity of dosage units <6.02> Perform the Mass variation test, or the Content uniformity test according to the following method: it meets the requirement.

To 1 tablet of Allopurinol Tablets add $V/10$ mL of 0.05 mol/L sodium hydroxide TS, shake well, and sonicate for 10 minutes. After cooling, add 0.1 mol/L hydrochloric acid TS to make exactly V mL so that each mL contains about 0.5 mg of allopurinol ($\text{C}_5\text{H}_4\text{N}_4\text{O}$), and filter through a membrane filter with a pore size not exceeding 0.8 μm . Discard the first 10 mL of the filtrate, pipet 2 mL of the subsequent filtrate, add 0.1 mol/L of hydrochloric acid TS to make exactly 100 mL, and use this solution as the sample solution. Separately, weigh accurately about 50 mg of allopurinol for assay, previously dried at 105°C for 4 hours, dissolve in 10 mL of 0.05 mol/L sodium hydroxide TS, and add 0.1 mol/L hydrochloric acid TS to make exactly 100 mL. Pipet 2 mL of this solution, add 0.1 mol/L hydrochloric acid TS to make exactly 100 mL, and use this solution as the standard solution. Determine the absorbances, A_T and A_S , of the sample solution and standard solution at 250 nm as directed under Ultraviolet-visible Spectrophotometry <2.24>.

$$\begin{aligned} &\text{Amount (mg) of allopurinol (C}_5\text{H}_4\text{N}_4\text{O)} \\ &= M_S \times A_T/A_S \times V/100 \end{aligned}$$

M_S : Amount (mg) of allopurinol for assay taken

Dissolution <6.10> When the test is performed at 50 revolutions per minute according to the Paddle method, using 900 mL of water as the dissolution medium, the dissolution rate in 30 minutes of Allopurinol Tablets is not less than 80%.

Start the test with 1 tablet of Allopurinol Tablets, withdraw not less than 20 mL of the medium at the specified minute after starting the test, and filter through a membrane filter with a pore size not exceeding 0.8 μm . Discard not less than 10 mL of the first filtrate, pipet V' mL of the subsequent filtrate, add water to make exactly V' mL so that each mL contains about 11 μg of allopurinol ($\text{C}_5\text{H}_4\text{N}_4\text{O}$), and use this solution as the sample solution. Separately, weigh accurately about 11 mg of allopurinol for assay, previously dried at 105°C for 4 hours, and dissolve in water to make exactly 100 mL. Pipet 5 mL of this solution, add water to make exactly 50 mL, and use this solution as the standard solution. Determine the absorbances, A_T and A_S , of the sample solution and standard solution at 250 nm as directed under Ultraviolet-visible Spectrophotometry <2.24>.

$$\begin{aligned} &\text{Dissolution rate (\%)} \text{ with respect to the labeled amount} \\ &\text{of allopurinol (C}_5\text{H}_4\text{N}_4\text{O)} \\ &= M_S \times A_T/A_S \times V'/V \times 1/C \times 90 \end{aligned}$$

M_S : Amount (mg) of allopurinol for assay taken

C : Labeled amount (mg) of allopurinol ($\text{C}_5\text{H}_4\text{N}_4\text{O}$) in 1 tablet

Assay Weigh accurately the mass of not less than 20 Allopurinol Tablets, and powder. Weigh accurately a portion of the powder, equivalent to about 0.1 g of allopurinol ($C_5H_4N_4O$), add 20 mL of 0.05 mol/L sodium hydroxide TS, shake well, and treat with ultrasonic waves for 10 minutes. After cooling, add 0.1 mol/L hydrochloric acid TS to make exactly 200 mL, and filter through a membrane filter with a pore size not exceeding $0.8 \mu\text{m}$. Discard the first 10 mL of the filtrate, pipet 2 mL of the subsequent filtrate, add 0.1 mol/L hydrochloric acid TS to make exactly 100 mL, and use this solution as the sample solution. Separately, weigh accurately about 0.1 g of allopurinol for assay, previously dried at 105°C for 4 hours, dissolve in 20 mL of 0.05 mol/L sodium hydroxide TS, and add 0.1 mol/L hydrochloric acid TS to make exactly 200 mL. Pipet 2 mL of this solution, add 0.1 mol/L hydrochloric acid TS to make exactly 100 mL, and use this solution as the standard solution. Determine the absorbances, A_T and A_S , of the sample solution and standard solution at 250 nm as directed under Ultraviolet-visible Spectrophotometry <2.24>.

$$\text{Amount (mg) of allopurinol (C}_5\text{H}_4\text{N}_4\text{O)} = M_S \times A_T/A_S$$

M_S : Amount (mg) of allopurinol for assay taken

Containers and storage Containers—Well-closed containers.

Alminoprofen

アルミノプロフェン

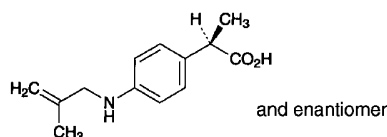

$C_{13}H_{17}NO_2$: 219.28
(2*RS*)-2-[[4-(2-Methylprop-2-en-1-yl)amino]phenyl]propanoic acid
[39718-89-3]

Alminoprofen, when dried, contains not less than 99.0% and not more than 101.0% of alminoprofen ($C_{13}H_{17}NO_2$).

Description Alminoprofen occurs as white to pale yellow, crystals or crystalline powder.

It is freely soluble in ethanol (99.5) and in acetic acid (100), and very slightly soluble in water.

It gradually turns brown on exposure to light.

A solution of Alminoprofen in ethanol (99.5) (1 in 10) shows no optical rotation.

Identification (1) Determine the absorption spectrum of a solution of Alminoprofen in ethanol (99.5) (3 in 500,000) as directed under Ultraviolet-visible Spectrophotometry <2.24>, and compare the spectrum with the Reference Spectrum: both spectra exhibit similar intensities of absorption at the same wavelengths.

(2) Determine the infrared absorption spectrum of Alminoprofen as directed in the potassium bromide disk method under Infrared Spectrophotometry <2.25>, and compare the spectrum with the Reference Spectrum: both spectra exhibit similar intensities of absorption at the same wave numbers.

Melting point <2.60> 106 – 108°C

Purity (1) Heavy metals <1.07>—Proceed with 2.0 g of Alminoprofen according to Method 2, and perform the test. Prepare the control solution with 2.0 mL of Standard Lead Solution (not more than 10 ppm).

(2) Arsenic <1.11>—Prepare the test solution with 1.0 g of Alminoprofen according to Method 3, and perform the test (not more than 2 ppm).

(3) Related substances—Conduct this procedure using light-resistant vessels. Dissolve 50 mg of Alminoprofen in 100 mL of the mobile phase, and use this solution as the sample solution. Pipet 2 mL of the sample solution, add the mobile phase to make exactly 200 mL, and use this solution as the standard solution. Perform the test with exactly 5 μL each of the sample solution and standard solution as directed under Liquid Chromatography <2.01> according to the following conditions. Determine each peak area of these solutions by the automatic integration method: the area of the peak other than alminoprofen obtained from the sample solution is not larger than 1/5 times the peak area of alminoprofen from the standard solution. Furthermore, the total area of the peaks other than alminoprofen from the sample solution is not larger than the peak area of alminoprofen from the standard solution.

Operating conditions—

Detector: An ultraviolet absorption photometer (wavelength: 254 nm).

Column: A stainless steel column 6.0 mm in inside diameter and 15 cm in length, packed with octadecylsilanized silica gel for liquid chromatography (5 μm in particle diameter).

Column temperature: A constant temperature of about 25°C .

Mobile phase: A mixture of methanol and diluted acetic acid (100) (1 in 1000) (4:1).

Flow rate: Adjust so that the retention time of alminoprofen is about 5 minutes.

Time span of measurement: About 5 times as long as the retention time of alminoprofen, beginning after the solvent peak.

System suitability—

Test for required detectability: Pipet 1 mL of the standard solution, and add the mobile phase to make exactly 10 mL. Confirm that the peak area of alminoprofen obtained with 5 μL of this solution is equivalent to 7 to 13% of that with 5 μL of the standard solution.

System performance: Dissolve 10 mg each of Alminoprofen and butyl parahydroxybenzoate in 100 mL of methanol. Pipet 10 mL of this solution, and add methanol to make exactly 50 mL. When the procedure is run with 5 μL of this solution under the above operating conditions, alminoprofen and butyl parahydroxybenzoate are eluted in this order with the resolution between these peaks being not less than 2.0.

System repeatability: When the test is repeated 6 times with 5 μL of the standard solution under the above operating conditions, the relative standard deviation of the peak area of alminoprofen is not more than 2.0%.

Loss on drying <2.41> Not more than 0.5% (1 g, in vacuum, phosphorus (V) oxide, 1 hour).

Residue on ignition <2.44> Not more than 0.1% (1 g).

Assay Weigh accurately about 0.3 g of Alminoprofen, previously dried, dissolve in 50 mL of acetic acid (100), and titrate <2.50> with 0.1 mol/L perchloric acid VS (potentiometric titration). Perform a blank determination in the same manner, and make any necessary correction.

Each mL of 0.1 mol/L perchloric acid VS
= 21.93 mg of $C_{13}H_{17}NO_2$

Containers and storage Containers—Well-closed containers.

Storage—Light-resistant.

Alminoprofen Tablets

アルミノプロフェン錠

Alminoprofen Tablets contain not less than 93.0% and not more than 107.0% of the labeled amount of alminoprofen ($C_{13}H_{17}NO_2$; 219.28).

Method of preparation Prepare as directed under Tablets, with Alminoprofen.

Identification Take an amount of powdered Alminoprofen Tablets, equivalent to 30 mg of Alminoprofen, add ethanol (99.5) to make 100 mL, shake thoroughly, and centrifuge. To 2 mL of the supernatant liquid add ethanol (99.5) to make 100 mL, and determine the absorption spectrum of this solution as directed under Ultraviolet-visible Spectrophotometry <2.24>: it exhibits maxima between 253 nm and 257 nm, and between 298 nm and 302 nm.

Purity Related substances—Conduct this procedure using light-resistant vessels. Powder 10 tablets of Alminoprofen Tablets, weigh a portion of the powder equivalent to 50 mg of Alminoprofen, add 50 mL of the mobile phase, shake for 15 minutes, add the mobile phase to make exactly 100 mL, centrifuge, and use the supernatant liquid as the sample solution. Pipet 2 mL of the sample solution, add the mobile phase to make exactly 200 mL, and use this solution as the standard solution. Perform the test with exactly 5 μ L each of the sample solution and standard solution as directed under Liquid Chromatography <2.01> according to the following conditions. Determine each peak area of each solution by the automatic integration method: the area of the peak other than alminoprofen obtained from the sample solution is not larger than 1/2 times the peak area of alminoprofen from the standard solution. Furthermore, the total area of the peaks other than alminoprofen from the sample solution is not larger than 2 times the peak area of alminoprofen from the standard solution.

Operating conditions—

Proceed as directed in the operating conditions in the Purity (3) under Alminoprofen.

System suitability—

Proceed as directed in the system suitability in the Purity (3) in Assay under Alminoprofen.

Uniformity of dosage units <6.02> Perform the test according to the following method: it meets the requirement of the Content uniformity test.

To 1 tablet of Alminoprofen Tablets add 5 mL of water, shake until the tablet is disintegrated, add 50 mL of ethanol (99.5), shake for 20 minutes, then add ethanol (99.5) to make exactly 100 mL, and centrifuge. Pipet 3 mL of the supernatant liquid, add ethanol (99.5) to make exactly 50 mL. Pipet V mL of this solution, add ethanol (99.5) to make exactly V' mL so that each mL contains about 6 μ g of alminoprofen ($C_{13}H_{17}NO_2$), and use this solution as the sample solution. Then, proceed as directed in the Assay.

$$\begin{aligned} &\text{Amount (mg) of alminoprofen (C}_{13}\text{H}_{17}\text{NO}_2\text{)} \\ &= M_S \times A_T/A_S \times V'/V \times 1/3 \end{aligned}$$

M_S : Amount (mg) of alminoprofen for assay taken

Dissolution <6.10> When the test is performed at 50 revolu-

tions per minute according to the Paddle method, using 900 mL of 2nd fluid for dissolution test as the dissolution medium, the dissolution rate in 45 minutes of Alminoprofen Tablets is not less than 80%.

Start the test with 1 tablet of Alminoprofen Tablets, withdraw not less than 20 mL of the medium at specified minute after starting the test, and filter through a membrane filter with a pore size not exceeding 0.45 μ m. Discard not less than 10 mL of the first filtrate, pipet V mL of the subsequent filtrate, add 0.05 mol/L sodium hydroxide TS to make exactly V' mL so that each mL contains about 8.9 μ g of alminoprofen ($C_{13}H_{17}NO_2$), and use this solution as the sample solution. Separately, weigh accurately about 30 mg of alminoprofen for assay, previously dried in vacuum for 1 hour using phosphorus (V) oxide as the desiccant, and dissolve in 0.05 mol/L sodium hydroxide TS to make exactly 100 mL. Pipet 3 mL of this solution, add 0.05 mol/L sodium hydroxide TS to make exactly 100 mL, and use this solution as the standard solution. Determine the absorbances, A_T and A_S , at 245 nm of the sample solution and standard solution as directed under Ultraviolet-visible Spectrophotometry <2.24>.

Dissolution rate (%) with respect to the labeled amount of alminoprofen ($C_{13}H_{17}NO_2$)

$$= M_S \times A_T/A_S \times V'/V \times 1/C \times 27$$

M_S : Amount (mg) of alminoprofen for assay taken

C : Labeled amount (mg) of alminoprofen ($C_{13}H_{17}NO_2$) in 1 tablet

Assay Weigh accurately the mass of not less than 20 tablets of Alminoprofen Tablets, and powder. Weigh accurately an amount equivalent to about 60 mg of alminoprofen ($C_{13}H_{17}NO_2$), add ethanol (99.5) and shake well, add ethanol (99.5) to make exactly 200 mL, and centrifuge. Pipet 2 mL of the supernatant liquid, add ethanol (99.5) to make exactly 100 mL, and use this solution as the sample solution. Separately, weigh accurately about 30 mg of alminoprofen for assay, previously dried in vacuum for 1 hour using phosphorus (V) oxide as the desiccant, dissolve in ethanol (99.5) to make exactly 100 mL. Pipet 2 mL of this solution, add ethanol (99.5) to make exactly 100 mL, and use this solution as the standard solution. Determine the absorbances, A_T and A_S , at the wavelength of maximum absorption at about 255 nm of the sample solution and standard solution as directed under Ultraviolet-visible Spectrophotometry <2.24>.

$$\begin{aligned} &\text{Amount (mg) of alminoprofen (C}_{13}\text{H}_{17}\text{NO}_2\text{)} \\ &= M_S \times A_T/A_S \times 2 \end{aligned}$$

M_S : Amount (mg) of alminoprofen for assay taken

Containers and storage Containers—Well-closed containers.

Alprazolam

アルプラゾラム

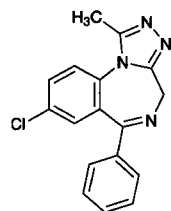

$C_{17}H_{13}ClN_4$: 308.76
8-Chloro-1-methyl-6-phenyl-4H-
[1,2,4]triazolo[4,3-a][1,4]benzodiazepine
[28981-97-7]

Alprazolam, when dried, contains not less than 98.5% of alprazolam ($C_{17}H_{13}ClN_4$).

Description Alprazolam occurs as white, crystals or crystalline powder.

It is freely soluble in chloroform, soluble in methanol and in ethanol (95), sparingly soluble in acetic anhydride, and practically insoluble in water.

It dissolves in dilute nitric acid.

Identification (1) Determine the absorption spectrum of a solution of Alprazolam in ethanol (95) (1 in 200,000) as directed under Ultraviolet-visible Spectrophotometry <2.24>, and compare the spectrum with the Reference Spectrum: both spectra exhibit similar intensities of absorption at the same wavelengths.

(2) Dissolve 0.05 g of Alprazolam in 0.7 mL of deuteriochloroform for nuclear magnetic resonance spectroscopy, and determine the spectrum of this solution using tetramethylsilane for nuclear magnetic resonance spectroscopy as an internal reference compound, as directed under Nuclear Magnetic Resonance Spectroscopy <2.21> (1H): it exhibits a single signal A at around δ 2.6 ppm, doublet signals B and C at around δ 4.0 ppm and δ 5.4 ppm, and a broad signal D between δ 7.1 ppm and 7.9 ppm. The ratio of integrated intensity of each signal, A:B:C:D, is about 3:1:1:8.

(3) Perform the test with Alprazolam as directed under Flame Coloration Test <1.04> (2): a green color appears.

Melting point <2.60> 228 – 232°C

Purity (1) Chloride <1.03>—Dissolve 0.5 g of Alprazolam in 10 mL of dilute nitric acid, and add water to make 50 mL. Perform the test using this solution as the test solution. Prepare the control solution with 0.20 mL of 0.01 mol/L hydrochloric acid VS (not more than 0.014%).

(2) Heavy metals <1.07>—Proceed with 2.0 g of Alprazolam according to Method 4, and perform the test. Prepare the control solution with 2.0 mL of Standard Lead Solution (not more than 10 ppm).

(3) Related substances—Dissolve 50 mg of Alprazolam in 10 mL of methanol, and use this solution as the sample solution. Pipet 1 mL of the sample solution, add methanol to make exactly 100 mL, then pipet 1 mL of this solution, add methanol to make exactly 10 mL, and use this solution as the standard solution. Perform the test with these solutions as directed under Thin-layer Chromatography <2.03>. Spot 20 μ L each of the sample solution and standard solution on a plate of silica gel with fluorescent indicator for thin-layer chromatography. Develop with a mixture of acetone, hexane, ethyl acetate and ethanol (95) (4:2:2:1) to a distance

of about 10 cm, and air-dry the plate. Examine under ultraviolet light (main wavelength: 254 nm): the spots other than the principal spot obtained from the sample solution are not more intense than the spot from the standard solution.

Loss on drying <2.41> Not more than 0.5% (1 g, reduced pressure not exceeding 0.67 kPa, 60°C, 4 hours).

Residue on ignition <2.44> Not more than 0.1% (1 g).

Assay Weigh accurately about 0.25 g of Alprazolam, previously dried, dissolve in 100 mL of acetic anhydride, and titrate <2.50> with 0.1 mol/L perchloric acid VS (potentiometric titration). Perform a blank determination in the same manner, and make any necessary correction.

Each mL of 0.1 mol/L perchloric acid VS
= 15.44 mg of $C_{17}H_{13}ClN_4$

Containers and storage Containers—Well-closed containers.

Alprenolol Hydrochloride

アルプレノロール塩酸塩

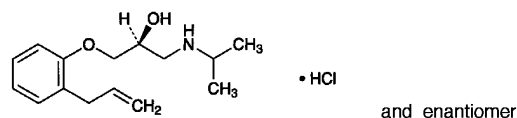

$C_{15}H_{23}NO_2 \cdot HCl$: 285.81
(2RS)-1-(2-Allylphenoxy)-3-
[(1-methylethyl)amino]propan-2-ol monohydrochloride
[13707-88-5]

Alprenolol Hydrochloride, when dried, contains not less than 99.0% of alprenolol hydrochloride ($C_{15}H_{23}NO_2 \cdot HCl$).

Description Alprenolol Hydrochloride occurs as white, crystals or crystalline powder.

It is freely soluble in water, in ethanol (95) and in acetic acid (100), slightly soluble in acetic anhydride, and practically insoluble in diethyl ether.

Identification (1) To 2 mL of a solution of Alprenolol Hydrochloride (1 in 100) add 0.05 mL of copper (II) sulfate TS and 2 mL of sodium hydroxide TS: a blue-purple color develops. To this solution add 1 mL of diethyl ether, shake well, and allow to stand: a red-purple color develops in the diethyl ether layer.

(2) Dissolve 0.05 g of Alprenolol Hydrochloride in 5 mL of water, add 1 to 2 drops of bromine TS, and shake: the color of the test solution disappears.

(3) Determine the absorption spectrum of a solution of Alprenolol Hydrochloride in ethanol (95) (1 in 10,000) as directed under Ultraviolet-visible Spectrophotometry <2.24>, and compare the spectrum with the Reference Spectrum: both spectra exhibit similar intensities of absorption at the same wavelengths.

(4) Determine the infrared absorption spectrum of Alprenolol Hydrochloride, previously dried, as directed in the potassium chloride disk method under Infrared Spectrophotometry <2.25>, and compare the spectrum with the Reference Spectrum: both spectra exhibit similar intensities of absorption at the same wave numbers.

(5) A solution of Alprenolol Hydrochloride (1 in 50) responds to Qualitative Tests <1.09> for chloride.

pH <2.54> Dissolve 1.0 g of Alprenolol Hydrochloride in 10 mL of water: the pH of this solution is between 4.5 and 6.0.

Melting point <2.60> 108 – 112°C

Purity (1) Clarity and color of solution—Dissolve 1.0 g of Alprenolol Hydrochloride in 10 mL of water: the solution is clear and colorless.

(2) Heavy metals <1.07>—Proceed with 2.0 g of Alprenolol Hydrochloride according to Method 2, and perform the test. Prepare the control solution with 2.0 mL of Standard Lead Solution (not more than 10 ppm).

(3) Arsenic <1.11>—Prepare the test solution with 1.0 g of Alprenolol Hydrochloride according to Method 3, and perform the test (not more than 2 ppm).

(4) Related substances—Dissolve 0.10 g of Alprenolol Hydrochloride in 10 mL of ethanol (95), and use this solution as the sample solution. Pipet 1 mL of the sample solution, and add ethanol (95) to make exactly 100 mL. Pipet 2.5 mL of this solution, add ethanol (95) to make exactly 10 mL, and use this solution as the standard solution. Perform the test with these solutions as directed under Thin-layer Chromatography <2.03>. Spot 10 μ L each of the sample solution and standard solution on a plate of silica gel for thin-layer chromatography. Develop the plate with a mixture of dichloromethane, acetone, acetic acid (100) and water (60:42:5:3) to a distance of about 10 cm, air-dry the plate, and then dry at 80°C for 30 minutes. After cooling, allow the plate to stand in iodine vapor for 30 minutes: the spots other than the principal spot and the spot on the starting point obtained from the sample solution are not more intense than the spot from the standard solution.

Loss on drying <2.41> Not more than 0.5% (1 g, in vacuum, silica gel, 4 hours).

Residue on ignition <2.44> Not more than 0.1% (1 g).

Assay Weigh accurately about 0.5 g of Alprenolol Hydrochloride, previously dried, dissolve in 50 mL of a mixture of acetic anhydride and acetic acid (100) (7:3), and titrate <2.50> with 0.1 mol/L perchloric acid VS (potentiometric titration). Perform a blank determination in the same manner, and make any necessary correction.

Each mL of 0.1 mol/L perchloric acid VS
= 28.58 mg of $C_{15}H_{23}NO_2 \cdot HCl$

Containers and storage Containers—Well-closed containers.

Alprostadil

アルプロスタジール

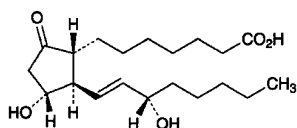

$C_{20}H_{34}O_5$: 354.48
7-[(1*R*,2*R*,3*R*)-3-Hydroxy-2-[(1*E*,3*S*)-3-hydroxyoct-1-en-1-yl]-5-oxocyclopentyl]heptanoic acid
[745-65-3]

Alprostadil, when dried, contains not less than 97.0% and not more than 103.0% of alprostadil ($C_{20}H_{34}O_5$).

Description Alprostadil occurs as white, crystals or crystalline powder.

It is freely soluble in ethanol (99.5) and in tetrahydrofuran, slightly soluble in acetonitrile, and practically insoluble in water.

Identification (1) The absorption spectrum of a solution of Alprostadil in ethanol (99.5) (1 in 100,000) determined as directed under Ultraviolet-visible Spectrophotometry <2.24> shows no absorption between 210 nm and 350 nm. Separately, to 10 mL of this solution add 1 mL of potassium hydroxide-ethanol TS, allow to stand for 15 minutes, and determine the absorption spectrum in the same way. Compare the spectrum so obtained with the Reference Spectrum or the spectrum of a solution of Alprostadil RS prepared in the same manner as the sample solution: both spectra exhibit similar intensities of absorption at the same wavelengths.

(2) Determine the infrared absorption spectrum of Alprostadil, previously dried, as directed in the potassium bromide disk method under Infrared Spectrophotometry <2.25>, and compare the spectrum with the Reference Spectrum or the spectrum of previously dried Alprostadil RS: both spectra exhibit similar intensities of absorption at the same wave numbers.

Optical rotation <2.49> $[\alpha]_D^{20}$: –53 – –61° (after drying, 25 mg, tetrahydrofuran, 5 mL, 100 mm).

Melting point <2.60> 114 – 118°C

Purity Related substances—Dissolve 4 mg of Alprostadil in 2 mL of a mixture of acetonitrile for liquid chromatography and water (9:1), and use this solution as the sample solution. Pipet 0.5 mL of the sample solution, and add the mixture of acetonitrile for liquid chromatography and water (9:1) to make exactly 10 mL. Pipet 2 mL of this solution, add the mixture of acetonitrile for liquid chromatography and water (9:1) to make exactly 10 mL, and use this solution as the standard solution. Perform the test with exactly 5 μ L each of the sample solution and standard solution as directed under Liquid Chromatography <2.01> according to the following conditions, and determine each peak area by the automatic integration method: the area of the peaks, having the relative retention time of about 0.70 and 1.26 to alprostadil, obtained from the sample solution is not larger than 1/2 times the peak area of alprostadil from the standard solution, the area of the peaks, having the relative retention time of about 0.88 and 1.18 to alprostadil, is not larger than the peak area of alprostadil from the standard solution, the area of the peaks other than alprostadil and the peaks mentioned above is not larger than 1/10 times the peak area of alprostadil from the standard solution and the total area of the peaks other than alprostadil is not larger than 2 times the peak area of alprostadil from the standard solution.

Operating conditions—

Detector, column, column temperature, mobile phase, and flow rate: Proceed as directed in the operating conditions in the Assay.

Time span of measurement: About 5 times as long as the retention time of alprostadil, beginning after the solvent peak.

System suitability—

System performance: Proceed as directed in the system suitability in the Assay.

Test for required detectability: Measure exactly 2 mL of the standard solution, add the mixture of acetonitrile for liquid chromatography and water (9:1) to make exactly 20 mL. Confirm that the peak area of alprostadil obtained with 5 μ L of this solution is equivalent to 7 to 13% of that with 5 μ L of

the standard solution.

System repeatability: When the test is repeated 6 times with 5 μL of the standard solution under the above operating conditions, the relative standard deviation of the peak area of alprostadil is not more than 1.5%.

Loss on drying <2.41> Not more than 1.0% (0.1 g, in vacuum, phosphorus (V) oxide, 4 hours).

Assay Weigh accurately about 5 mg each of Alprostadil and Alprostadil RS, previously dried, dissolve in exactly 5 mL of the internal standard solution, add a mixture of acetonitrile for liquid chromatography and water (9:1) to make 50 mL, and use these solutions as the sample solution and standard solution, respectively. Perform the test with 5 μL each of the sample solution and standard solution as directed under Liquid Chromatography <2.01> according to the following conditions, and calculate the ratios, Q_T and Q_S , of the peak area of alprostadil to that of the internal standard.

$$\text{Amount (mg) of alprostadil (C}_{20}\text{H}_{34}\text{O}_5) = M_S \times Q_T/Q_S$$

M_S : Amount (mg) of Alprostadil RS taken

Internal standard solution—A solution of dimethyl phthalate in the mixture of acetonitrile for liquid chromatography and water (9:1) (1 in 10,000).

Operating conditions—

Detector: An ultraviolet absorption photometer (wavelength: 196 nm).

Column: A stainless steel column 4.6 mm in inside diameter and 15 cm in length, packed with octadecylsilanized silica gel for liquid chromatography (5 μm in particle diameter).

Column temperature: A constant temperature of about 40°C.

Mobile phase: Dissolve 9.07 g of potassium dihydrogen phosphate in water to make 1000 mL. Adjust the pH to 6.3 with a solution prepared by dissolving 9.46 g of disodium hydrogen phosphate in water to make 1000 mL, and dilute to 10 times its volume with water. To 360 mL of this solution add 110 mL of acetonitrile for liquid chromatography and 30 mL of methanol for liquid chromatography.

Flow rate: Adjust so that the retention time of alprostadil is about 10 minutes.

System suitability—

System performance: When the procedure is run with 5 μL of the standard solution under the above operating conditions, alprostadil and the internal standard are eluted in this order with the resolution between these peaks being not less than 9.

System repeatability: When the test is repeated 6 times with 5 μL of the standard solution under the above operating conditions, the relative standard deviation of the ratio of the peak area of alprostadil to that of the internal standard is not more than 1.0%.

Containers and storage Containers—Tight containers.

Storage—Light-resistant, and at a temperature not exceeding 5°C.

Alprostadil Injection

アルプロスタジル注射液

Alprostadil Injection is an emulsion-type injection.

It contains not less than 80.0% and not more than 125.0% of the labeled amount of alprostadil ($\text{C}_{20}\text{H}_{34}\text{O}_5$; 354.48).

Method of preparation Prepare as directed under Injections, with Alprostadil.

Description Alprostadil Injection occurs as a white emulsion and is slightly viscous. It has a distinctive odor.

Identification To a quantity of Alprostadil Injection, corresponding to 10 μg of Alprostadil, add 2 mL of acetonitrile, shake well, and centrifuge. To 3.5 mL of the supernatant liquid add 7 mL of diluted phosphoric acid (1 in 1000), and then run this solution on a column (prepared by filling a 10 mm inside diameter, 9 mm long chromatography tube with 0.4 g of 70 μm octadecylsilanized silica gel for pretreatment) prewashed with 10 mL of methanol and then 10 mL of water. Wash the column with 10 mL of water and then 20 mL of petroleum ether, followed by elution with 2.5 mL of a mixture of methanol and water (4:1). Remove the solvent from the effluent under reduced pressure, dissolve the residue in 100 μL of ethyl acetate, and use this solution as the sample solution. Separately, dissolve 1 mg of Alprostadil RS in 10 mL of ethyl acetate, and use this solution as the standard solution. Perform the test with these solutions as directed under Thin-layer Chromatography <2.03>. Spot the entire volume of the sample solution and 100 μL of the standard solution on a plate of silica gel for thin-layer chromatography. Then, develop the plate with a mixture of ethyl acetate, ethanol (99.5) and acetic acid (100) (100:5:1) to a distance of about 10 cm, and air-dry the plate. Spray evenly a solution of phosphomolybdic acid *n*-hydrate in ethanol (99.5) (1 in 10) on the plate, and heat at 100°C for 5 minutes: the color of the spot obtained from the standard solution and the spot corresponding to that location obtained from the sample solution is dark blue.

pH Being specified separately when the drug is granted approval based on the Law.

Purity (1) Heavy metals <1.07>—Proceed with 4.0 mL of Alprostadil Injection according to Method 2, and perform the test. Prepare the control solution with 2.0 mL of Standard Lead Solution (not more than 5 ppm).

(2) Prostaglandin A_1 —Use the sample solution obtained in the Assay as the sample solution. Separately, weigh accurately about 10 mg of prostaglandin A_1 , previously dried for 4 hours in a desiccator (in vacuum, phosphorus (V) oxide), and dissolve in ethanol (99.5) to make exactly 100 mL. Pipet 2.5 mL of this solution, and add the mobile phase to make exactly 50 mL. Pipet 1 mL of this solution, add exactly 1 mL of the internal standard solution, and use this solution as the standard solution. Perform the test with 40 μL each of the sample solution and standard solution as directed under Liquid Chromatography <2.01> according to the following conditions, calculate the ratios, Q_T and Q_S , of the peak area of prostaglandin A_1 to that of the internal standard, and calculate the amount of prostaglandin A_1 converted to alprostadil using the following equation: not more than 3.0 μg per a volume, equivalent to 5 μg of alprostadil ($\text{C}_{20}\text{H}_{34}\text{O}_5$).

Amount (μg) of prostaglandin A_1 ($C_{20}H_{32}O_4$), converted to alprostadil

$$= M_S \times Q_T/Q_S \times 1/2 \times 1.054$$

M_S : Amount (mg) of prostaglandin A_1 taken

Internal standard solution—Dissolve 50 mg of 1-naphthol in 20 mL of ethanol (99.5). To 3 mL of this solution add the mobile phase to make 100 mL.

Operating conditions—

Proceed as directed in the operating conditions in the Assay.

System suitability—

System performance, and system repeatability: Proceed as directed in the system suitability in the Assay.

Test for required detectability: To exactly 1 mL of the standard solution add the mobile phase to make exactly 5 mL. Confirm that the peak area of prostaglandin A_1 obtained with 40 μL of this solution is equivalent to 14 to 26% of that with 40 μL of the standard solution.

(3) Peroxide—Pipet 4 mL of Alprostadil Injection, place in a glass-stoppered flask, add 15 mL of a mixture of acetic acid (100) and isooctane (3:2), previously having undergone a 30 minute nitrogen substitution, and dissolve with gentle shaking. To this solution add 0.5 mL of saturated potassium iodide TS, replace the inside of the vessel with nitrogen, and shake for exactly 5 minutes. Then, add 0.5 mL of starch TS, shake vigorously, add 15 mL of water, and shake vigorously. Under a stream of nitrogen, titrate <2.50> with 0.01 mol/L sodium thiosulfate VS until the color of the solution disappears. Separately, perform a blank determination using 4 mL of water, and make any necessary correction. Calculate the amount of peroxides using the following equation: not more than 0.5 meq/L.

$$\text{Amount (meq/L) of peroxides} = V \times 2.5$$

V : Amount (mL) of 0.01 mol/L sodium thiosulfate VS consumed

(4) Free fatty acids—Pipet 3 mL of Alprostadil Injection, add exactly 15 mL of a mixture of 2-propanol, heptane and 0.5 mol/L sulfuric acid TS (40:10:1), and shake for 1 minute. After leaving for 10 minutes, add exactly 9 mL of heptane and exactly 9 mL of water, shake the test tube by inverting 10 times, leave for 15 minutes, and pipet 9 mL of the supernatant liquid. To this solution, add 3 mL of a solution prepared by combining 1 volume of Nile blue solution (1 in 5000) washed 5 times with heptane and 9 volumes of ethanol (99.5), and use this solution as the sample solution. Titrate <2.50> this solution with 0.02 mol/L sodium hydroxide VS under a stream of nitrogen. Separately, dissolve 5.65 g of oleic acid in heptane to make exactly 200 mL, and use this solution as the standard solution. Pipet 25 mL of the standard solution, add 2 drops of phenolphthalein TS, titrate <2.50> with 0.1 mol/L potassium hydroxide-ethanol VS until a light red color develops, and determine the correction factor f . Pipet 30 mL of the standard solution and add heptane to make exactly 200 mL. Pipet 3 mL of this solution, add exactly 15 mL of a mixture of 2-propanol, heptane and 0.5 mol/L sulfuric acid TS (40:10:1), and shake for 1 minute. After leaving for 10 minutes, add exactly 6 mL of heptane and exactly 12 mL of water, shake the test tube by inverting 10 times, and then titrate <2.50> in the same manner as for the sample solution. Determine the volume (mL), V_T and V_S , of 0.02 mol/L sodium hydroxide VS consumed by the sample and standard solutions: the amount of free fatty acid is not more than 12.0 meq/L.

$$\text{Amount (meq/L) of free fatty acids} = V_T/V_S \times f \times 15$$

Bacterial endotoxins <4.01> Less than 10 EU/mL.

Extractable volume <6.05> It meets the requirement.

Foreign insoluble matter <6.06> Perform the test according to Method 1: it meets the requirement.

Sterility <4.06> Perform the test according to the Membrane filter method: it meets the requirement. However, use the sample solution consisting of equal volume of Alprostadil Injection and a solution prepared by adding water to 0.1 g of polysorbate 80 to make 100 mL.

Particle diameter Being specified separately when the drug is granted approval based on the Law.

Assay Measure exactly a volume of Alprostadil Injection corresponding to 5 μg of alprostadil ($C_{20}H_{34}O_5$), add exactly 1 mL of the internal standard solution, shake, and use this solution as the sample solution. Separately, weigh accurately about 5 mg of Alprostadil RS, previously dried in a desiccator (in vacuum, phosphorus (V) oxide) for 4 hours, dissolve in ethanol (99.5) to make exactly 50 mL, and use this solution as standard stock solution. Pipet 2.5 mL of the standard stock solution, add the mobile phase to make exactly 50 mL, pipet 1 mL, add exactly 1 mL of the internal standard solution, and use this solution as the standard solution. Perform the test with 40 μL each of the sample solution and standard solution as directed under Liquid Chromatography <2.01> according to the following conditions using an apparatus equipped with an automatic pretreatment device (using a postcolumn reaction), and calculate the ratios, Q_T and Q_S , of the peak area of alprostadil to that of the internal standard.

$$\text{Amount } (\mu\text{g}) \text{ of alprostadil } (C_{20}H_{34}O_5) = M_S \times Q_T/Q_S$$

M_S : Amount (mg) of Alprostadil RS taken

Internal standard solution—Dissolve 50 mg of 1-naphthol in 20 mL of ethanol (99.5). To 3 mL of this solution add the mobile phase to make 100 mL.

Operating conditions—

Equipment: Liquid chromatograph consisting of 2 pumps for pumping the mobile phase and the reaction reagent, an automatic pretreatment device, column, reaction coil, detector, and recording apparatus. Use a reaction coil that is maintained at a constant temperature.

Detector: An ultraviolet absorption photometer (wavelength: 278 nm).

Column: A stainless steel column 4.6 mm in inside diameter and 15 cm in length, packed with octadecylsilanized silica gel for liquid chromatography (5 μm in particle diameter).

Column temperature: A constant temperature of about 60°C.

Reaction coil: Polytetrafluoroethylene tube 0.5 mm in inside diameter and 10 m in length.

Mobile phase: Dissolve 9.07 g of potassium dihydrogen phosphate in water to make 1000 mL and adjust the pH to 6.3 by adding a solution prepared by dissolving 9.46 g of disodium hydrogen phosphate in water to make 1000 mL. To 1 volume of this solution add 9 volumes of water. To 3 volumes of this solution add 1 volume of acetonitrile for liquid chromatography.

Reaction reagent: Potassium hydroxide TS.

Reaction temperature: A constant temperature of about 60°C.

Mobile phase flow rate: Adjust so that the retention time of alprostadil is about 7 minutes.

Reaction reagent flow rate: 0.5 mL per minute.

Automatic pretreatment device: Composed of a pretreatment column, pump for pumping pretreatment column wash

solution, and routing valve for 2 high pressure flow paths.

Pretreatment column: A stainless steel column 4 mm in inside diameter and 2.5 cm in length, packed with octadecylsilanized silica gel for liquid chromatography (5 μ m in particle diameter).

Pretreatment column wash solution: Ethanol (99.5).

Flow rate of wash solution: A constant flow rate of about 2.0 mL per minute.

Flow path operating conditions: Change the flow path operating conditions at the times shown in the table below using the valves shown in the figure.

Valve	Time of switchover (minutes)				
	0	9.0	9.1	*1)	*2)
RVA	0	0	1	0	0
RVB	0	1	1	1	0

*1) After the internal standard has completely eluted

*2) 0.1 minutes after *1)

System suitability—

System performance: Dissolve 10 mg of prostaglandin A₁, previously dried in a desiccator (in vacuum, phosphorus (V) oxide) for 4 hours, in ethanol (99.5) to make 100 mL. To 2.5 mL of this solution add 2.5 mL of the standard stock solution, and add the mobile phase to make 50 mL. To 1 mL of this solution add 1 mL of the internal standard solution, shake, and perform the test under the above conditions with 40 μ L of the solution. Alprostadil, prostaglandin A₁ and the internal standard are eluted in this order, and the resolution between the peaks of alprostadil and prostaglandin A₁ is not less than 10, and that between prostaglandin A₁ and the internal standard is not less than 2.0.

System repeatability: When the test is repeated 6 times with 40 μ L of the standard solution under the above conditions, the relative standard deviation of the ratio of the peak area of alprostadil to that of the internal standard is not more than 2.0%.

Containers and storage Containers—Hermetic containers.

Storage—Light-resistant, not exceeding 5°C, avoiding freezing.

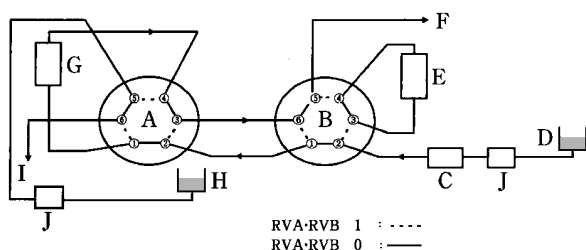

- A: RVA valve
 B: RVB valve
 C: Sample injector
 D: Mobile phase
 E: Column for pressure correction
 F: Column
 G: Pretreatment column
 H: Wash solution
 I: Drain
 J: Pump

Figure Components of automatic pretreatment system

Alprostadil Alfadex

アルプロスタジル アルファデクス

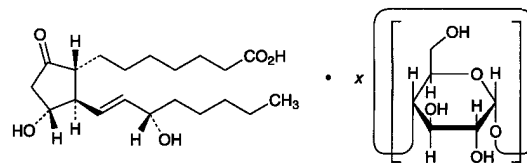

$C_{20}H_{34}O_5 \cdot x C_{36}H_{60}O_{30}$

7-[(1*R*,2*R*,3*R*)-3-Hydroxy-2-[(1*E*,3*S*)-3-hydroxyoct-1-en-1-yl]-5-oxocyclopentyl]heptanoic acid— α -cyclodextrin [55648-20-9]

Alprostadil Alfadex is a α -cyclodextrin clathrate compound of alprostadil.

It contains not less than 2.8% and not more than 3.2% of alprostadil ($C_{20}H_{34}O_5$: 354.48), calculated on the anhydrous basis.

Description Alprostadil Alfadex occurs as a white powder.

It is freely soluble in water, and practically insoluble in ethanol (95), in ethyl acetate and in diethyl ether.

It is hygroscopic.

Identification (1) Dissolve 0.02 g of Alprostadil Alfadex in 5 mL of water, add 5 mL of ethyl acetate, shake, and centrifuge. Use the supernatant liquid as the sample solution (1). Separately, to 0.02 g of Alprostadil Alfadex add 5 mL of ethyl acetate, shake, and centrifuge. Use the supernatant liquid as the sample solution (2). Evaporate the solvent from these solutions under reduced pressure, add 2 mL of sulfuric acid to the residue, and shake for 5 minutes: the liquid obtained from the sample solution (1) shows an orange-yellow color, while the liquid obtained from the sample solution (2) does not show that color.

(2) Dissolve 0.02 g of Alprostadil Alfadex in 5 mL of water, add 5 mL of ethyl acetate, shake, centrifuge, and evaporate the solvent from the supernatant liquid under reduced pressure. Dissolve the residue in 2 mL of ethanol (95), add 5 mL of 1,3-dinitrobenzene TS, then add 5 mL of a solution of potassium hydroxide in ethanol (95) (17 in 100) under ice-cooling, and allow to stand for 20 minutes in a dark place under ice-cooling: a purple color develops.

(3) Dissolve 0.05 g of Alprostadil Alfadex in 1 mL of iodine TS, by heating on a water bath, and allow to stand: a dark blue precipitate is formed.

(4) Determine the absorption spectrum of a solution of Alprostadil Alfadex in dilute ethanol (3 in 10,000) as directed under Ultraviolet-visible Spectrophotometry <2.24>: it exhibits no absorption between 220 nm and 400 nm. Separately, to 10 mL of the solution add 1 mL of potassium hydroxide-ethanol TS, allow to stand for 15 minutes, and determine the absorption spectrum as directed under Ultraviolet-visible Spectrophotometry <2.24>, and compare the spectrum with the Reference Spectrum: both spectra exhibit similar intensities of absorption at the same wavelengths.

Optical rotation <2.49> $[\alpha]_D^{20}$: +126 – +138° (0.1 g calculated on the anhydrous basis, dilute ethanol, 20 mL, 100 mm).

pH <2.54> Dissolve 0.10 g of Alprostadil Alfadex in 20 mL of water: the pH of this solution is between 4.0 and 5.0.

Purity (1) Clarity and color of solution—Dissolve 1.0 g of Alprostadil Alfadex in 10 mL of water: the solution is col-

orless. Perform the test with this solution as directed under Ultraviolet-visible Spectrophotometry within 30 minutes after preparation of the solution: the absorbance at 450 nm is not larger than 0.10.

(2) Prostaglandin A₁—Dissolve 0.10 g of Alprostadil Alfadex in 5 mL of water, add exactly 5 mL of the internal standard solution and ethanol (95) to make 15 mL, and use this solution as the sample solution. Separately, dissolve 1.5 mg of prostaglandin A₁ in ethanol (95) to make exactly 100 mL. Pipet 3 mL of this solution, add exactly 5 mL of the internal standard solution, 2 mL of ethanol (95) and water to make 15 mL, and use this solution as the standard solution. Perform the test with 10 μL each of the sample solution and standard solution as directed under Liquid Chromatography <2.01> according to the operating conditions described in the Assay, and calculate the ratios, Q_T and Q_S , of the peak area of prostaglandin A₁ to that of the internal standard: Q_T is not larger than Q_S .

Internal standard solution—A solution of propyl parahydroxybenzoate in dilute ethanol (1 in 15,000).

(3) Related substances—Dissolve 0.10 g of Alprostadil Alfadex in 3 mL of water, add exactly 3 mL of ethyl acetate, shake, centrifuge, and use the supernatant liquid obtained as the sample solution. Separately, dissolve 1.0 mg of prostaglandin A₁ in ethyl acetate to make exactly 100 mL, and use this solution as the standard solution. Perform the test with these solutions as directed under Thin-layer Chromatography <2.03>. Spot 10 μL each of the sample solution and standard solution on a plate of silica gel for thin-layer chromatography. Develop the plate with a mixture of ethyl acetate, hexane and acetic acid (100) (10:2:1) to a distance of about 10 cm, and air-dry the plate. Spray evenly a solution of phosphomolybdic acid *n*-hydrate in ethanol (95) (1 in 4) on the plate, and heat the plate at 100°C for 5 minutes: the spots other than the principal spot obtained from the sample solution, and the spots other than the spot corresponding to the spot from the standard solution are all not more intense than the spot from the standard solution.

Water <2.48> Not more than 6.0% (0.2 g, direct titration).

Assay Weigh accurately about 0.1 g of Alprostadil Alfadex, dissolve in 5 mL of water, add exactly 5 mL of the internal standard solution and water to make 15 mL, and use this solution as the sample solution. Separately, weigh accurately about 3 mg of Alprostadil RS, dissolve in 5 mL of ethanol (95), add exactly 5 mL of the internal standard solution and water to make 15 mL, and use this solution as the standard solution. Perform the test with 10 μL each of the sample solution and standard solution as directed under Liquid Chromatography <2.01> according to the following conditions, and calculate the ratios, Q_T and Q_S , of the peak area of alprostadil to that of the internal standard.

$$\begin{aligned} & \text{Amount (mg) of alprostadil (C}_{20}\text{H}_{34}\text{O}_5) \\ & = M_S \times Q_T/Q_S \end{aligned}$$

M_S : Amount (mg) of Alprostadil RS taken

Internal standard solution—A solution of propyl parahydroxybenzoate in dilute ethanol (1 in 15,000).

Operating conditions—

Detector: An ultraviolet absorption photometer (wavelength: 205 nm).

Column: A stainless steel column about 5 mm in inside diameter and about 15 cm in length, packed with octadecylsilanized silica gel for liquid chromatography (5 μm in particle diameter).

Column temperature: A constant temperature of about

25°C.

Mobile phase: A mixture of 0.02 mol/L potassium dihydrogenphosphate and acetonitrile (3:2).

Flow rate: Adjust so that the retention time of alprostadil is about 6 minutes.

Selection of column: Dissolve about 0.1 g of Alprostadil Alfadex in 5 mL of water, add 5 mL of a solution of prostaglandin A₁ in ethanol (95) (3 in 200,000) and 5 mL of the internal standard solution. Proceed with 10 μL of this solution under the above operating conditions, and calculate the resolution. Use a column giving elution of alprostadil, the internal standard and prostaglandin A₁ in this order and complete separation of these peaks.

Containers and storage Containers—Tight containers.

Storage—Light-resistant, at a temperature not exceeding 5°C.

Alum Solution

ミヨウバン水

Alum Solution contains not less than 0.27 w/v% and not more than 0.33 w/v% of aluminum potassium sulfate Hydrate [AlK(SO₄)₂·12H₂O: 474.39].

Method of preparation

Aluminum Potassium Sulfate Hydrate	3 g
Mentha Water	50 mL
Water, Purified Water or Purified Water in Containers	a sufficient quantity
To make 1000 mL	

Dissolve and mix the above ingredients.

Description Alum Solution is a clear, colorless liquid. It has the odor of the mentha oil and an astringent taste.

Identification (1) To 5 mL of Alum Solution add 3 mL of ammonium chloride TS and 1 mL of ammonia TS: a white, gelatinous precipitate is produced, which changes to red upon the addition of 5 drops of alizarin red S TS (aluminum sulfate).

(2) Place 100 mL of Alum Solution in an evaporating dish, evaporate on a water bath to dryness, and dissolve the residue in 5 mL of water: the solution responds to Qualitative Tests <1.09> for potassium salt.

(3) Alum Solution responds to the Qualitative Tests <1.09> (1) and (2) for sulfate.

Assay Pipet 50 mL of Alum Solution, add exactly 30 mL of 0.02 mol/L disodium dihydrogen ethylenediamine tetraacetate VS, and further add 20 mL of acetic acid-ammonium acetate buffer solution (pH 4.8). Boil for 5 minutes, cool, add 55 mL of ethanol (95), and titrate <2.50> with 0.02 mol/L zinc acetate VS (indicator: 2 mL of dithizone TS), until the color of the solution changes from light dark green to light red. Perform a blank determination in the same manner.

$$\begin{aligned} & \text{Each mL of 0.02 mol/L disodium dihydrogen ethylene-} \\ & \text{diamine tetraacetate VS} \\ & = 9.488 \text{ mg of AlK(SO}_4\text{)}_2\cdot 12\text{H}_2\text{O} \end{aligned}$$

Containers and storage Containers—Tight containers.

Dried Aluminum Hydroxide Gel

乾燥水酸化アルミニウムゲル

Dried Aluminum Hydroxide Gel contains not less than 50.0% of aluminum oxide (Al_2O_3 ; 101.96).

Description Dried Aluminum Hydroxide Gel occurs as a white, amorphous powder. It is odorless and tasteless.

It is practically insoluble in water, in ethanol (95) and in diethyl ether.

Most of it dissolves in dilute hydrochloric acid and in sodium hydroxide TS.

Identification To 0.2 g of Dried Aluminum Hydroxide Gel add 20 mL of dilute hydrochloric acid, warm, and centrifuge: the supernatant liquid responds to Qualitative Tests <1.09> for aluminum salt.

Purity (1) Acidity or alkalinity—To 1.0 g of Dried Aluminum Hydroxide Gel add 25 mL of water, shake well, and centrifuge: the supernatant liquid is neutral.

(2) Chloride <1.03>—To 1.0 g of Dried Aluminum Hydroxide Gel add 30 mL of dilute nitric acid, heat gently to boil while shaking, cool, add water to make 100 mL, and centrifuge. To 5 mL of the supernatant liquid add 6 mL of dilute nitric acid and water to make 50 mL. Perform the test using this solution as the test solution. Prepare the control solution with 0.40 mL of 0.01 mol/L hydrochloric acid VS (not more than 0.284%).

(3) Sulfate <1.14>—To 1.0 g of Dried Aluminum Hydroxide Gel add 15 mL of dilute hydrochloric acid, heat gently to boil while shaking, cool, add water to make 250 mL, and centrifuge. To 25 mL of the supernatant liquid add 1 mL of dilute hydrochloric acid and water to make 50 mL. Perform the test using this solution as the test solution. Prepare the control solution with 1.0 mL of 0.005 mol/L sulfuric acid VS (not more than 0.480%).

(4) Nitrate—To 0.10 g of Dried Aluminum Hydroxide Gel add 5 mL of water, then carefully add 5 mL of sulfuric acid, shake well to dissolve, and cool. Superimpose the solution on 2 mL of iron (II) sulfate TS: no brown-colored ring is produced at the zone of contact.

(5) Heavy metals <1.07>—Dissolve 2.0 g of Dried Aluminum Hydroxide Gel in 10 mL of dilute hydrochloric acid by heating, filter if necessary, and add water to make 50 mL. Perform the test with this solution as the test solution. Prepare the control solution as follows: evaporate 10 mL of dilute hydrochloric acid to dryness, and add 2.0 mL of Standard Lead Solution, 2 mL of dilute acetic acid and water to make 50 mL (not more than 10 ppm).

(6) Arsenic <1.11>—To 0.8 g of Dried Aluminum Hydroxide Gel add 10 mL of dilute sulfuric acid, heat gently to boil while shaking, cool, and filter. Take 5 mL of the filtrate, use this solution as the test solution, and perform the test (not more than 5 ppm).

Acid-consuming capacity Weigh accurately about 0.2 g of Dried Aluminum Hydroxide Gel, and transfer to a glass-stoppered flask. Add exactly 100 mL of 0.1 mol/L hydrochloric acid VS, stopper the flask, shake at $37 \pm 2^\circ\text{C}$ for 1 hour, and filter. Measure exactly 50 mL of the filtrate, and titrate <2.50> while thoroughly stirring, the excess hydrochloric acid with 0.1 mol/L sodium hydroxide VS until the pH of the solution becomes to 3.5. The volume of 0.1 mol/L hydrochloric acid VS consumed is not less than 250 mL per g of Dried Aluminum Hydroxide Gel.

Assay Weigh accurately about 2 g of Dried Aluminum Hydroxide Gel, add 15 mL of hydrochloric acid, heat on a water bath with shaking for 30 minutes, cool, and add water to make exactly 500 mL. Pipet 20 mL of this solution, add exactly 30 mL of 0.05 mol/L disodium dihydrogen ethylenediamine tetraacetate VS and 20 mL of acetic acid (31)-ammonium acetate buffer solution (pH 4.8), boil for 5 minutes, and cool. Add 55 mL of ethanol (95), and titrate <2.50> with 0.05 mol/L zinc acetate VS until the color of the solution changes from light dark green to light red. (indicator: 2 mL of dithizone TS). Perform a blank determination in the same manner, and make any necessary correction.

Each mL of 0.05 mol/L disodium dihydrogen ethylenediamine tetraacetate VS
= 2.549 mg of Al_2O_3

Containers and storage Containers—Tight containers.

Dried Aluminum Hydroxide Gel Fine Granules

乾燥水酸化アルミニウムゲル細粒

Dried Aluminum Hydroxide Gel Fine Granules contain not less than 47.0% of aluminum oxide (Al_2O_3 ; 101.96).

Method of preparation Prepare as directed under Granules, with Dried Aluminum Hydroxide Gel.

Identification To 0.2 g of Dried Aluminum Hydroxide Gel Fine Granules add 20 mL of dilute hydrochloric acid, warm and centrifuge: the supernatant liquid responds to Qualitative Tests <1.09> for aluminum salt.

Acid-consuming capacity Proceed as directed for Acid-consuming capacity under Dried Aluminum Hydroxide Gel: the volume of 0.1 mol/L hydrochloric acid VS consumed is not less than 235 mL per g of Dried Aluminum Hydroxide Gel Fine Granules.

Assay Proceed as directed in the Assay under Dried Aluminum Hydroxide Gel.

Each mL of 0.05 mol/L disodium dihydrogen ethylenediamine tetraacetate VS
= 2.549 mg of Al_2O_3

Containers and storage Containers—Tight containers.

Aluminum Monostearate

モノステアリン酸アルミニウム

Aluminum Monostearate is mainly aluminum compounds of stearic acid ($\text{C}_{18}\text{H}_{36}\text{O}_2$; 284.48) and palmitic acid ($\text{C}_{16}\text{H}_{32}\text{O}_2$; 256.42).

Aluminum Monostearate, when dried, contains not less than 7.2% and not more than 8.9% of aluminum (Al; 26.98).

Description Aluminum Monostearate occurs as a white to yellow-white powder. It is odorless or has a faint, characteristic odor.

It is practically insoluble in water, in ethanol (95) and in diethyl ether.

Identification (1) Heat 3 g of Aluminum Monostearate with 30 mL of hydrochloric acid in a water bath with occasional shaking for 10 minutes. After cooling, shake the mixture vigorously with 50 mL of water and 30 mL of diethyl ether for 3 minutes, and allow to stand. To the separated aqueous layer add sodium hydroxide TS until the solution becomes slightly turbid, and filter: the filtrate responds to Qualitative Tests <1.09> for aluminum salt.

(2) Wash the diethyl ether layer separated in (1) with two 20-mL portions of water, and evaporate the diethyl ether layer on a water bath: the residue melts <1.13> at above 54°C.

Acid value for fatty acid <1.13> 193–210. Weigh accurately about 1 g of fatty acid obtained in the Identification (2), transfer a 250-mL glass-stoppered flask, add 100 mL of a mixture of diethyl ether and ethanol (95) (2:1), warm to dissolve, add several drops of phenolphthalein TS, and proceed as directed under Acid Value.

Purity (1) Free fatty acid—Mix 1.0 g of Aluminum Monostearate with about 50 mL of a mixture of neutralized ethanol and diethyl ether (1:1), filter through dry filter paper, wash the vessel and the filter paper with a small amount of a mixture of neutralized ethanol and diethyl ether (1:1), combine the filtrate and the washings, and add 2.1 mL of 0.1 mol/L potassium hydroxide VS: a red color develops.

(2) Water-soluble salts—Heat 2.0 g of Aluminum Monostearate with 80 mL of water in a loosely stoppered conical flask on a water bath for 30 minutes with occasional shaking. After cooling, filter through dry filter paper, wash the residue with a small amount of water, combine the washings with the filtrate, add water to make 100 mL, evaporate 50 mL of this solution on a water bath, and heat strongly at 600°C: the mass of the residue is not more than 10.0 mg.

(3) Heavy metals <1.07>—Heat 1.0 g of Aluminum Monostearate over a small flame with caution at the beginning, and continue the heating, gradually raising the temperature, to ash. After cooling, add 10 mL of diluted hydrochloric acid (1 in 2), evaporate on a water bath, and boil the residue with 20 mL of water for 1 minute. Cool, filter, wash the residue with water, combine the filtrate and the washings, and add 2 mL of dilute acetic acid and water to make 50 mL. Perform the test using this solution as the test solution. Evaporate 10 mL of diluted hydrochloric acid (1 in 2) on a water bath to dryness, add 2 mL of dilute acetic acid and 5.0 mL of Standard Lead Solution, dilute with water to make 50 mL, and use this solution as the control solution (not more than 50 ppm).

(4) Arsenic <1.11>—Mix 1.0 g of Aluminum Monostearate with 2 g of magnesium nitrate hexahydrate, ignite over a small flame, moisten the residue after cooling with 0.5 mL of nitric acid, and heat. Heat again the residue with 10 mL of dilute sulfuric acid until white fumes evolve, add water to make 5 mL, and perform the test with this solution as the test solution (not more than 2 ppm).

Loss on drying <2.41> Not more than 3.0% (1 g, 105°C, 3 hours).

Assay Weigh accurately about 1 g of Aluminum Monostearate, previously dried, ignite gently to ash, and cool. Add dropwise 0.5 mL of nitric acid, evaporate on a water bath by heating, and then heat strongly between 900°C and 1100°C to a constant mass. After cooling, weigh rapidly the ignited residue, and designate the mass as aluminum oxide (Al₂O₃: 101.96).

Amount (mg) of aluminum (Al)

= amount (mg) of aluminum oxide (Al₂O₃) × 0.529

Containers and storage Containers—Well-closed containers.

Dried Aluminum Potassium Sulfate

Burnt Alum

乾燥硫酸アルミニウムカリウム

AlK(SO₄)₂: 258.21

Dried Aluminum Potassium Sulfate, when dried, contains not less than 98.0% of aluminum potassium sulfate [AlK(SO₄)₂].

Description Dried Aluminum Potassium Sulfate occurs as white masses or white powder. It is odorless. It has a slightly sweet, astringent taste.

It is freely soluble in hot water and practically insoluble in ethanol (95).

It dissolves slowly in water.

Identification A solution of Dried Aluminum Potassium Sulfate (1 in 20) responds to Qualitative Tests <1.09> for aluminum salt, to Qualitative Tests <1.09> (1), (3) and (4) for potassium salt, and to Qualitative Tests <1.09> (1) and (3) for sulfate.

Purity (1) Water-insoluble substances—To 2.0 g of Dried Aluminum Potassium Sulfate add 40 mL of water, shake frequently, and allow to stand for 48 hours. Collect the insoluble residue on a glass filter (G4), wash with 50 mL of water, and dry at 105°C for 2 hours: the mass of the residue is not more than 50 mg.

(2) Heavy metals <1.07>—Dissolve 0.5 g of Dried Aluminum Potassium Sulfate in 45 mL of water, and filter, if necessary. Add 2 mL of dilute acetic acid and water to make 50 mL, and perform the test using this solution as the test solution. Prepare the control solution with 2.0 mL of Standard Lead Solution, 2 mL of dilute acetic acid and water to make 50 mL (not more than 40 ppm).

(3) Iron <1.10>—Prepare the test solution with 0.54 g of Dried Aluminum Potassium Sulfate according to Method 1, and perform the test according to Method A. Prepare the control solution with 2.0 mL of Standard Iron Solution (not more than 37 ppm).

(4) Arsenic <1.11>—Prepare the test solution with 0.40 g of Dried Aluminum Potassium Sulfate, according to Method 1, and perform the test (not more than 5 ppm).

Loss on drying <2.41> Not more than 15.0% (2 g, 200°C, 4 hours).

Assay Weigh accurately about 1.2 g of Dried Aluminum Potassium Sulfate, previously dried, add 80 mL of water, and heat on a water bath with occasional shaking for 20 minutes. Cool, add water to make exactly 100 mL, and filter, if necessary. Discard the first 30 mL of the filtrate, take exactly the subsequent 20 mL of the filtrate, and add exactly 30 mL of 0.05 mol/L disodium dihydrogen ethylenediamine tetraacetate VS and 20 mL of acetic acid-ammonium acetate buffer solution (pH 4.8), boil for 5 minutes, and cool. Add 55 mL of ethanol (95), and titrate <2.50> with 0.05 mol/L zinc acetate VS (indicator: 2 mL of dithizone TS), until the color of the solution changes from light dark

green to light red. Perform a blank determination in the same manner.

Each mL of 0.05 mol/L disodium dihydrogen ethylenediamine tetraacetate VS
= 12.91 mg of AlK(SO₄)₂

Containers and storage Containers—Tight containers.

Aluminum Potassium Sulfate Hydrate

Alum

硫酸アルミニウムカリウム水和物

AlK(SO₄)₂·12H₂O: 474.39

Aluminum Potassium Sulfate Hydrate contains not less than 99.5% of aluminum potassium sulfate hydrate [AlK(SO₄)₂·12H₂O].

Description Aluminum Potassium Sulfate Hydrate occurs as colorless or white, crystals or powder. It is odorless. It has a slightly sweet, strongly astringent taste.

It is freely soluble in water, and practically insoluble in ethanol (95) and in diethyl ether.

A solution of Aluminum Potassium Sulfate Hydrate (1 in 20) is acid.

Identification A solution of Aluminum Potassium Sulfate Hydrate (1 in 10) responds to Qualitative Tests <1.09> for aluminum salt, to Qualitative Tests <1.09> (1), (3) and (4) for potassium salt, and to the Qualitative Tests <1.09> (1) and (3) for sulfate.

Purity (1) Heavy metals <1.07>—Proceed with 1.0 g of Aluminum Potassium Sulfate Hydrate according to Method 1, and perform the test. Prepare the control solution with 2.0 mL of Standard Lead Solution (not more than 20 ppm).

(2) Iron <1.10>—Prepare the test solution with 1.0 g of Aluminum Potassium Sulfate Hydrate according to Method 1, and perform the test according to Method A. Prepare the control solution with 2.0 mL of Standard Iron Solution (not more than 20 ppm).

(3) Arsenic <1.11>—Prepare the test solution with 0.6 g of Aluminum Potassium Sulfate Hydrate, according to Method 1, and perform the test (not more than 3.3 ppm).

Assay Weigh accurately about 4.5 g of Aluminum Potassium Sulfate Hydrate, and dissolve in water to make exactly 200 mL. Take exactly 20 mL of this solution, and add exactly 30 mL of 0.05 mol/L disodium dihydrogen ethylenediamine tetraacetate VS and 20 mL of acetic acid-ammonium acetate buffer solution (pH 4.8), boil for 5 minutes, and cool. Add 55 mL of ethanol (95), and titrate <2.50> with 0.05 mol/L zinc acetate VS (indicator: 2 mL of dithizone TS), until the color of the solution changes from light dark green to light red. Perform a blank determination in the same manner.

Each mL of 0.05 mol/L disodium dihydrogen ethylenediamine tetraacetate VS
= 23.72 mg of AlK(SO₄)₂·12H₂O

Containers and storage Containers—Tight containers.

Natural Aluminum Silicate

天然ケイ酸アルミニウム

Description Natural Aluminum Silicate occurs as a white or slightly colored powder. It is odorless and tasteless.

It is practically insoluble in water, in ethanol (95) and in diethyl ether.

Natural Aluminum Silicate (1 g) dissolves when heated in 20 mL of a solution of sodium hydroxide (1 in 5), with some decomposition, leaving a large amount of insoluble substance.

Identification (1) To 0.5 g of Natural Aluminum Silicate add 3 mL of diluted sulfuric acid (1 in 3), heat until white fumes evolve, cool, add 20 mL of water, and filter. Render the filtrate slightly acid with ammonia TS: the solution responds to Qualitative Tests <1.09> for aluminum salt.

(2) Prepare a bead by fusing ammonium sodium hydrogenphosphate tetrahydrate on a platinum loop. Place the bead in contact with Natural Aluminum Silicate, and fuse again: an infusible material appears in the bead, producing, upon cooling, an opaque bead with a web-like structure.

Purity (1) Acidity or alkalinity—Shake 5.0 g of Natural Aluminum Silicate with 100 mL of water, and centrifuge: the supernatant liquid so obtained is neutral.

(2) Chloride <1.03>—To 5.0 g of Natural Aluminum Silicate add 100 mL of water, boil gently for 15 minutes while shaking, then cool, add water to restore the original volume, and centrifuge. To 10 mL of the supernatant liquid add 6 mL of dilute nitric acid, dilute to 50 mL with water, and perform the test using this solution as the test solution. Prepare the control solution with 0.30 mL of the 0.01 mol/L hydrochloric acid VS (not more than 0.021%).

(3) Sulfate <1.14>—To the residue obtained in (6) add 3 mL of dilute hydrochloric acid, heat on a water bath for 10 minutes, dilute to 50 mL with water, and filter. To 2.0 mL of the filtrate add 1 mL of dilute hydrochloric acid and water to make 50 mL. Perform the test using this solution as the test solution. Prepare the control solution with 1.0 mL of 0.005 mol/L sulfuric acid VS (not more than 0.480%).

(4) Heavy metals <1.07>—To 1.5 g of Natural Aluminum Silicate add 50 mL of water and 5 mL of hydrochloric acid, boil gently for 20 minutes while shaking, then cool, centrifuge, remove the supernatant liquid, wash the residue with two 10-mL portions of water, centrifuging each time, combine these washings with the filtrate, and add ammonia solution (28) dropwise, until a precipitate just appears. Add dropwise dilute hydrochloric acid with vigorous shaking and redissolve the precipitate. Heat the mixture with 0.45 g of hydroxylammonium chloride, cool, and add 0.45 g of sodium acetate trihydrate, 6 mL of dilute acetic acid and water to make 150 mL. Perform the test, using 50 mL of this solution as the test solution. Prepare the control solution with 2.0 mL of Standard Lead Solution, 0.15 g of hydroxylammonium chloride, 0.15 g of sodium acetate trihydrate, 2 mL of dilute acetic acid and water to make 50 mL (not more than 40 ppm).

(5) Arsenic <1.11>—To 1.0 g of Natural Aluminum Silicate, add 5 mL of dilute hydrochloric acid, heat gently to boil while shaking well, cool rapidly, and centrifuge. Mix the residue with 5 mL of dilute hydrochloric acid with shaking, centrifuge, then add 10 mL of water to the residue, and repeat the extraction in the same manner. Concentrate the

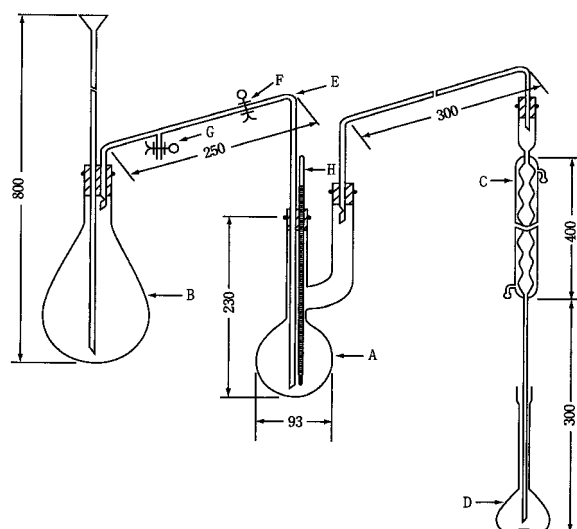

The figures are in mm.

- A: Distilling flask of about 300-mL capacity.
 B: Steam generator of about 1000-mL capacity, containing a few boiling tips to prevent bumping
 C: Condenser
 D: Receiver: 200-mL volumetric flask
 E: Steam-introducing tube having an internal diameter of about 8 mm
 F, G: Rubber tube with a clamp
 H: Thermometer

combined extracts on a water bath to 5 mL. Use this solution as the test solution, and perform the test (not more than 2 ppm).

(6) Soluble salts—Evaporate 50 mL of the supernatant liquid obtained in (1) on a water bath to dryness, and ignite the residue at 700°C for 2 hours: the mass of the ignited residue is not more than 40 mg.

(7) Fluoride—(i) Apparatus: Use a hard glass apparatus as illustrated in the figure. Ground-glass joints may be used.

(ii) Procedure: Transfer 5.0 g of Natural Aluminum Silicate to the distilling flask A with the aid of 20 mL of water, add about 1 g of glass wool and 50 mL of diluted purified sulfuric acid (1 in 2), and connect A to the distillation apparatus, previously washed with steam streamed through the steam introducing tube E. Connect the condenser C with the receiver D containing 10 mL of 0.01 mol/L sodium hydroxide VS and 10 mL of water so that the lower end of C is immersed in the solution. Heat A gradually until the temperature of the solution in A reaches 130°C, then open the rubber tube F, close the rubber tube G, boil water in the steam generator B vigorously, and introduce the generated steam into F. Simultaneously, heat A, and maintain the temperature of the solution in A between 135°C and 145°C. Adjust the distilling rate to about 10 mL per minute. Collect about 170 mL of the distillate, then stop the distillation, wash C with a small quantity of water, combine the washings with the distillate, add water to make exactly 200 mL, and use this solution as the test solution. Perform the test with the test solution as directed in the procedure of determination for fluoride under Oxygen Flask Combustion Method <1.06>. No corrective solution is used in this procedure. The content of fluoride (F) is not more than 0.01%.

$$\begin{aligned} &\text{Amount (mg) of fluoride (F: 19.00) in the test solution} \\ &= \text{amount (mg) of fluoride in 5 mL of} \\ &\quad \text{the standard solution} \\ &\quad \times A_T/A_S \times 200/V \end{aligned}$$

Loss on drying <2.41> Not more than 20.0% (1 g, 105°C, 3 hours).

Adsorptive power To 0.10 g of Natural Aluminum Silicate add 20 mL of a solution of methylene blue trihydrate (3 in 2000), shake for 15 minutes, allow to stand for 5 hours at 37 ± 2°C, and centrifuge. Dilute 1.0 mL of the supernatant liquid with water to 200 mL. Place 50 mL of the solution in a Nessler tube and observe horizontally or vertically against a white background: the color of the solution is not deeper than that of the following control solution.

Control solution: Dilute 1.0 mL of a solution of methylene blue trihydrate (3 in 2000) with water to 400 mL, and use 50 mL of this solution.

Containers and storage Containers—Well-closed containers.

Synthetic Aluminum Silicate

合成ケイ酸アルミニウム

Description Synthetic Aluminum Silicate occurs as a white powder. It is odorless and tasteless.

It is practically insoluble in water, in ethanol (95) and in diethyl ether.

Synthetic Aluminum Silicate (1 g) dissolves when heated in 20 mL of a solution of sodium hydroxide (1 in 5), leaving a small amount of insoluble substance.

Identification (1) To 0.5 g of Synthetic Aluminum Silicate add 3 mL of diluted sulfuric acid (1 in 3), heat until white fumes evolve, cool, add 20 mL of water, and filter. Render the filtrate slightly acid with ammonia TS: the solution responds to Qualitative Tests <1.09> for aluminum salt.

(2) Prepare a bead by fusing ammonium sodium hydrogenphosphate tetrahydrate on a platinum loop. Place the bead in contact with Synthetic Aluminum Silicate, and fuse again: an infusible material appears in the bead, producing, upon cooling, an opaque bead with a web-like structure.

Purity (1) Acidity or alkalinity—Shake 1.0 g of Synthetic Aluminum Silicate with 20 mL of water, and centrifuge: the supernatant liquid so obtained is neutral.

(2) Chloride <1.03>—To 5.0 g of Synthetic Aluminum Silicate add 100 mL of water, boil gently for 15 minutes while shaking, then cool, add water to restore the original volume, and centrifuge. To 10 mL of the supernatant liquid add 6 mL of dilute nitric acid and water to make 50 mL, and perform the test using this solution as the test solution. Prepare the control solution with 0.30 mL of 0.01 mol/L hydrochloric acid VS (not more than 0.021%).

(3) Sulfate <1.14>—To 2.0 mL of the supernatant liquid obtained in (2) add 1 mL of dilute hydrochloric acid and water to make 50 mL. Perform the test using this solution as the test solution. Prepare the control solution with 1.0 mL of 0.005 mol/L sulfuric acid VS (not more than 0.480%).

(4) Heavy metals <1.07>—To 3.0 g of Synthetic Aluminum Silicate add 50 mL of water and 5 mL of hydrochloric acid, boil gently for 20 minutes while shaking, then after cooling, centrifuge, remove the supernatant liquid, wash the precipitate with two 10-mL portions of water, centrifuging

each time, combine these washings with the filtrate, and add ammonia solution (28) dropwise until a precipitate just appears. Add dropwise dilute hydrochloric acid with vigorous shaking to redissolve the precipitate. Heat the solution with 0.45 g of hydroxylammonium chloride, and after cooling, add 0.45 g of sodium acetate trihydrate, 6 mL of dilute acetic acid and water to make 150 mL. Perform the test with 50 mL of this solution as the test solution. Prepare the control solution with 3.0 mL of Standard Lead Solution, 0.15 g of hydroxylammonium chloride, 0.15 g of sodium acetate trihydrate, 2 mL of dilute acetic acid and water to make 50 mL (not more than 30 ppm).

(5) Arsenic <1.11>—To 1.0 g of Synthetic Aluminum Silicate add 10 mL of dilute hydrochloric acid, heat gently to boiling while shaking well, cool rapidly, and centrifuge. Mix the residue with 5 mL of dilute hydrochloric acid with shaking, centrifuge, then add 10 mL of water to the residue, and repeat the extraction in the same manner. Concentrate the combined extracts on a water bath to 5 mL. Use this solution as the test solution, and perform the test (not more than 2 ppm).

Loss on drying <2.41> Not more than 20.0% (1 g, 105°C, 3 hours).

Acid-consuming capacity <6.04> Weigh accurately about 1 g of Synthetic Aluminum Silicate, transfer to a glass-stoppered flask, add 200 mL of 0.1 mol/L hydrochloric acid VS, exactly measured, stopper the flask, and shake at $37 \pm 2^\circ\text{C}$ for 1 hour. Filter, pipet 50 mL of the filtrate, and titrate <2.50> by stirring well the excess hydrochloric acid with 0.1 mol/L sodium hydroxide VS until the pH of the solution changes to 3.5. The volume of 0.1 mol/L hydrochloric acid VS consumed is not less than 50.0 mL per g of Synthetic Aluminum Silicate.

Containers and storage Containers—Well-closed containers.

Amantadine Hydrochloride

アマンタジン塩酸塩

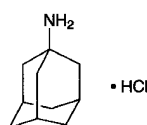

$\text{C}_{10}\text{H}_{17}\text{N}\cdot\text{HCl}$: 187.71
Tricyclo[3.3.1.1^{3,7}]dec-1-ylamine monohydrochloride
[665-66-7]

Amantadine Hydrochloride, when dried, contains not less than 99.0% of amantadine hydrochloride ($\text{C}_{10}\text{H}_{17}\text{N}\cdot\text{HCl}$).

Description Amantadine Hydrochloride occurs as a white crystalline powder. It is odorless, and has a bitter taste.

It is very soluble in formic acid, freely soluble in water, in methanol and in ethanol (95), and practically insoluble in diethyl ether.

Identification (1) To 0.1 g of Amantadine Hydrochloride add 1 mL of pyridine and 0.1 mL of acetic anhydride, dissolve by boiling for 1 minute, add 10 mL of dilute hydrochloric acid, and cool in ice water. Filter the crystals separated, wash with water, and dry at 105°C for 1 hour: the residue melts <2.60> between 147°C and 151°C.

(2) Determine the infrared absorption spectrum of Amantadine Hydrochloride, previously dried, as directed in the potassium chloride disk method under Infrared Spectrophotometry <2.25>, and compare the spectrum with the Reference Spectrum: both spectra exhibit similar intensities of absorption at the same wave numbers.

(3) A solution of Amantadine Hydrochloride (1 in 50) responds to Qualitative Tests <1.09> for chloride.

pH <2.54> Dissolve 1.0 g of Amantadine Hydrochloride in 5 mL of water: the pH of this solution is between 4.0 and 6.0.

Purity (1) Clarity and color of solution—Dissolve 1.0 g of Amantadine Hydrochloride in 10 mL of water: the solution is clear and colorless.

(2) Heavy metals <1.07>—Proceed with 2.0 g of Amantadine Hydrochloride according to Method 4, and perform the test. Prepare the control solution with 2.0 mL of Standard Lead Solution (not more than 10 ppm).

(3) Arsenic <1.11>—Prepare the test solution with 1.0 g of Amantadine Hydrochloride according to Method 3, and perform the test (not more than 2 ppm).

(4) Related substances—Dissolve 0.50 g of Amantadine Hydrochloride in 10 mL of water, add 10 mL of sodium hydroxide TS and 10 mL of chloroform, and shake. Filter the chloroform layer through absorbent cotton with 3 g of anhydrous sodium sulfate on a funnel, and use the filtrate as the sample solution. Pipet 1 mL of the sample solution, add chloroform to make exactly 100 mL, and use this solution as the standard solution. Perform the test with exactly 2 μL each of the sample solution and standard solution as directed under Gas Chromatography <2.02> according to the following conditions. Determine each peak area of these solutions by the automatic integration method: each peak area other than amantadine obtained from the sample solution is not larger than 1/3 times the peak area of amantadine from the standard solution, and the total area of each peak is not larger than the peak area of amantadine from the standard solution.

Operating conditions—

Detector: A hydrogen flame-ionization detector.

Column: A glass column about 3 mm in inside diameter and about 2 m in length, packed with siliceous earth for gas chromatography (150 to 180 μm in particle diameter) coated with a mixture (L) of branched hydrocarbon of petroleum hexamethyltetracosane group for gas chromatography and potassium hydroxide at the ratios of 2% and 1%, respectively.

Column temperature: Inject at a constant temperature of about 125°C, maintain the temperature for 5 minutes, raise at the rate of 5°C per minute to 150°C, and maintain at a constant temperature of about 150°C for 15 minutes.

Carrier gas: Nitrogen.

Flow rate: Adjust so that the retention time of amantadine is about 11 minutes.

Selection of column: Dissolve 0.15 g of naphthalene in 5 mL of the sample solution, and add chloroform to make 100 mL. Proceed with 2 μL of this solution under the above operating conditions, and calculate the resolution. Use a column giving elution of naphthalene and amantadine in this order with the resolution between these peaks being not less than 2.5.

Detection sensitivity: Adjust the detection sensitivity so that the peak height of amantadine obtained from 2 μL of the standard solution composes about 10% of the full scale.

Time span of measurement: About twice as long as the retention time of amantadine, beginning after the solvent

peak.

Loss on drying <2.41> Not more than 0.5% (1 g, 105°C, 3 hours).

Residue on ignition <2.44> Not more than 0.2% (1 g).

Assay Weigh accurately about 0.2 g of Amantadine Hydrochloride, previously dried, dissolve in 2 mL of formic acid, add exactly 15 mL of 0.1 mol/L perchloric acid VS, and heat on a water bath for 30 minutes. After cooling, add acetic acid (100) to make 70 mL, and titrate <2.50> the excess perchloric acid with 0.1 mol/L sodium acetate VS (potentiometric titration). Perform a blank determination in the same manner, and make any necessary correction.

Each mL of 0.1 mol/L perchloric acid VS
= 18.77 mg of C₁₀H₁₇N.HCl

Containers and storage Containers—Well-closed containers.

Ambenonium Chloride

アンベノニウム塩化物

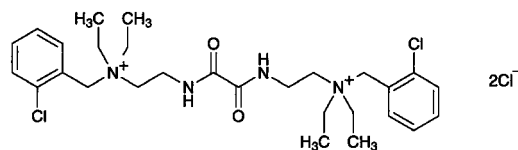

C₂₈H₄₂Cl₄N₄O₂: 608.47
2,2'-[(1,2-Dioxoethane-1,2-diyl)diimino]bis[N-(2-chlorobenzyl)-N,N-diethylethylaminium] dichloride
[115-79-7]

Ambenonium Chloride contains not less than 98.5% of ambenonium chloride (C₂₈H₄₂Cl₄N₄O₂), calculated on the dried basis.

Description Ambenonium Chloride occurs as a white powder.

It is freely soluble in water, in methanol and in acetic acid (100), soluble in ethanol (95), and slightly soluble in acetic anhydride.

It is hygroscopic.

Melting point: about 205°C (with decomposition).

Identification (1) Determine the absorption spectrum of a solution of Ambenonium Chloride in methanol (1 in 5000) as directed under Ultraviolet-visible Spectrophotometry <2.24>, and compare the spectrum with the Reference Spectrum: both spectra exhibit similar intensities of absorption at the same wavelengths.

(2) Determine the infrared absorption spectrum of Ambenonium Chloride, previously dried, as directed in the potassium chloride disk method under Infrared Spectrophotometry <2.25>, and compare the spectrum with the Reference Spectrum: both spectra exhibit similar intensities of absorption at the same wave numbers.

(3) A solution of Ambenonium Chloride (1 in 100) responds to Qualitative Tests <1.09> for chloride.

Purity (1) Clarity and color of solution—Dissolve 1.0 g of Ambenonium Chloride in 10 mL of water: the solution is clear and colorless.

(2) Heavy metals <1.07>—Proceed with 1.0 g of Ambenonium Chloride according to Method 4, and perform the test. Use a solution of magnesium nitrate in ethanol (95)

(1 in 5). Prepare the control solution with 2.0 mL of Standard Lead Solution (not more than 20 ppm).

(3) Related substances—Dissolve 0.10 g of Ambenonium Chloride in 10 mL of methanol, and use this solution as the sample solution. Pipet 1 mL of the sample solution, and add methanol to make exactly 20 mL. Pipet 1 mL of this solution, add methanol to make exactly 10 mL, and use this solution as the standard solution. Perform the test with these solutions as directed under Thin-layer Chromatography <2.03>. Spot 5 μL each of the sample solution and standard solution on a plate of silica gel for thin-layer chromatography. Develop the plate with a mixture of 1-butanol, formic acid and water (12:6:5) to a distance of about 10 cm, and air-dry the plate. Allow the plate to stand in iodine vapor: the spots other than the principal spot obtained from the sample solution are not more intense than the spot from the standard solution.

Loss on drying <2.41> Not more than 11.5% (1 g, 105°C, 4 hours).

Residue on ignition <2.44> Not more than 0.2% (1 g).

Assay Weigh accurately about 0.3 g of Ambenonium Chloride, and dissolve in 50 mL of a mixture of acetic anhydride and acetic acid (100) (7:3). Titrate <2.50> with 0.1 mol/L perchloric acid VS (potentiometric titration). Perform a blank determination in the same manner, and make any necessary correction.

Each mL of 0.1 mol/L perchloric acid VS
= 30.42 mg of C₂₈H₄₂Cl₄N₄O₂

Containers and storage Containers—Tight containers.

Amidotrizoic Acid

アミドトリゾ酸

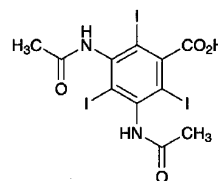

C₁₁H₉I₃N₂O₄: 613.91
3,5-Bis(acetylamino)-2,4,6-triiodobenzoic acid
[117-96-4]

Amidotrizoic Acid, calculated on the dried basis, contains not less than 98.0% of amidotrizoic acid (C₁₁H₉I₃N₂O₄).

Description Amidotrizoic Acid occurs as a white crystalline powder. It is odorless.

It is slightly soluble in ethanol (95), very slightly soluble in water, and practically insoluble in diethyl ether.

It dissolves in sodium hydroxide TS.

Identification (1) Heat 0.1 g of Amidotrizoic Acid over a flame: a purple gas is evolved.

(2) Determine the infrared absorption spectrum of Amidotrizoic Acid as directed in the potassium bromide disk method under Infrared Spectrophotometry <2.25>, and compare the spectrum with the Reference Spectrum: both spectra exhibit similar intensities of absorption at the same wave numbers.

Purity (1) Clarity and color of solution—Dissolve 1.0 g

of Amidotrizoic Acid in 10 mL of 0.2 mol/L sodium hydroxide TS: the solution is clear and colorless.

(2) Primary aromatic amines—Dissolve 0.20 g of Amidotrizoic Acid in 5 mL of water and 1 mL of sodium hydroxide TS, add 4 mL of a solution of sodium nitrite (1 in 100) and 10 mL of 1 mol/L hydrochloric acid TS, shake, and allow to stand for 2 minutes. Add 5 mL of ammonium amidosulfate TS, shake well, allow to stand for 1 minute, and add 0.4 mL of a solution of 1-naphthol in ethanol (95) (1 in 10), 15 mL of sodium hydroxide TS and water to make exactly 50 mL. Determine the absorbance of this solution at 485 nm as directed under Ultraviolet-visible Spectrophotometry <2.24> using a solution, prepared in the same manner, as the blank: the absorbance is not more than 0.15.

(3) Soluble halides—Dissolve 2.5 g of Amidotrizoic Acid in 20 mL of water and 2.5 mL of ammonia TS, add 20 mL of dilute nitric acid and water to make 100 mL, allow to stand for 15 minutes with occasional shaking, and filter. Discard the first 10 mL of the filtrate, transfer the subsequent 25 mL of the filtrate to a Nessler tube, and add ethanol (95) to make 50 mL. Proceed as directed under Chloride Limit Test <1.03> using this solution as the test solution. Prepare the control solution as follows: to 0.10 mL of 0.01 mol/L hydrochloric acid VS, add 6 mL of dilute nitric acid and water to make 25 mL, then ethanol (95) to make 50 mL.

(4) Iodine—Dissolve 0.20 g of Amidotrizoic Acid in 2.0 mL of sodium hydroxide TS, add 2.5 mL of 0.5 mol/L sulfuric acid TS, allow to stand for 10 minutes with occasional shaking, add 5 mL of chloroform, shake well, and allow to stand: the solution is colorless in the chloroform layer.

(5) Heavy metals <1.07>—Proceed with 2.0 g of Amidotrizoic Acid according to Method 2, and perform the test. Prepare the control solution with 2.0 mL of Standard Lead Solution (not more than 10 ppm).

(6) Arsenic <1.11>—Prepare the test solution with 0.6 g of Amidotrizoic Acid according to Method 3, and perform the test (not more than 3.3 ppm).

Loss on drying <2.41> Not more than 7.0% (1 g, 105°C, 4 hours).

Residue on ignition <2.44> Not more than 0.1% (1 g).

Assay Transfer about 0.5 g of Amidotrizoic Acid, accurately weighed, to a saponification flask, dissolve in 40 mL of sodium hydroxide TS, add 1 g of zinc powder, connect to a reflux condenser, boil for 30 minutes, cool, and filter. Wash the flask and the filter paper with 50 mL of water, and combine the washings and the filtrate. Add 5 mL of acetic acid (100) to this solution, and titrate <2.50> with 0.1 mol/L silver nitrate VS until the color of the precipitate changes from yellow to green (indicator: 1 mL of tetrabromophenolphthalein ethyl ester TS).

$$\begin{aligned} \text{Each mL of 0.1 mol/L silver nitrate VS} \\ = 20.46 \text{ mg of } C_{11}H_{13}N_2O_4 \end{aligned}$$

Containers and storage Containers—Tight containers. Storage—Light-resistant.

Amikacin Sulfate

アミカシン硫酸塩

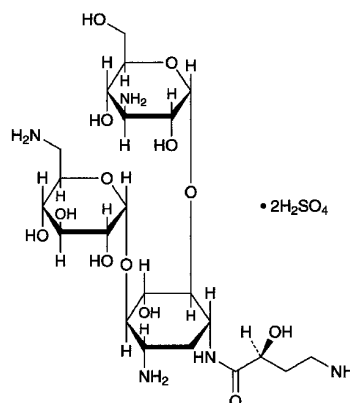

$C_{22}H_{43}N_5O_{13} \cdot 2H_2SO_4$: 781.76
3-Amino-3-deoxy- α -D-glucopyranosyl-(1 \rightarrow 6)-
[6-amino-6-deoxy- α -D-glucopyranosyl-(1 \rightarrow 4)]-1-*N*-
[(2*S*)-4-amino-2-hydroxybutanoyl]-2-deoxy-D-streptamine
disulfate
[39831-55-5]

Amikacin Sulfate is the sulfate of a derivative of kanamycin.

It contains not less than 691 μ g (potency) and not more than 791 μ g (potency) per mg, calculated on the dried basis. The potency of Amikacin Sulfate is expressed as mass (potency) of amikacin ($C_{22}H_{43}N_5O_{13}$: 585.60).

Description Amikacin Sulfate occurs as a white to yellow-white powder.

It is very soluble in water, and practically insoluble in ethanol (95).

Identification (1) Determine the infrared absorption spectrum of Amikacin Sulfate, previously dried, as directed in the potassium bromide disk method under Infrared Spectrophotometry <2.25>, and compare the spectrum with the Reference Spectrum or the spectrum of Amikacin Sulfate RS previously dried: both spectra exhibit similar intensities of absorption at the same wave numbers.

(2) Dissolve 0.1 g each of Amikacin Sulfate and Amikacin Sulfate RS in 4 mL of water, and use these solutions as the sample solution and standard solution. Perform the test with these solutions as directed under Thin-layer chromatography <2.03>. Spot 2 μ L each of the sample solution and standard solution on a plate of silica gel for thin-layer chromatography. Develop the plate with a mixture of water, ammonia water (28), methanol and tetrahydrofuran (1:1:1:1) to a distance of about 10 cm, and air-dry the plate. Spray evenly ninhydrin-citric acid-acetic acid TS on the plate, and heat at 100°C for 10 minutes: the principal spot obtained from the sample solution and the spot from the standard solution show a red-purple color and the same R_f value.

(3) A solution of Amikacin Sulfate (1 in 100) responds to Qualitative Tests <1.09> (1) for sulfate.

Optical rotation <2.49> $[\alpha]_D^{20}$: +76 – +84° (1 g, water, 100 mL, 100 mm).

pH <2.54> Dissolve 1.0 g of Amikacin Sulfate in 100 mL of water: the pH of the solution is between 6.0 and 7.5.

Purity (1) Heavy metals <1.07>—Proceed with 1.0 g of

Amikacin Sulfate according to Method 2, and perform the test. Prepare the control solution with 2.0 mL Standard Lead Solution (not more than 20 ppm).

(2) Related substances—Dissolve 0.10 g of Amikacin Sulfate in 4 mL of a water, and use this solution as the sample solution. Pipet 1 mL of the sample solution, add water to make exactly 100 mL, and use this solution as the standard solution. Perform the test with these solutions as directed under Thin-layer chromatography <2.03>. Spot 2 μ L each of the sample solution and standard solution on a plate of silica gel for thin-layer chromatography. Develop the plate with a mixture of water, ammonia water (28), methanol and tetrahydrofuran (1:1:1:1) to a distance of about 10 cm, and air-dry the plate. Spray evenly ninhydrin-citric acid-acetic acid TS on the plate, and heat the plate at 100°C for 10 minutes: the spots other than the principal spot obtained from the sample solution are not more intense than the spot from the standard solution.

Loss on drying <2.41> Not more than 4.0% (1 g, in vacuum, 60°C, 3 hours).

Assay Weigh accurately an amount of Amikacin Sulfate and Amikacin Sulfate RS, equivalent to about 50 mg (potency), dissolve each in water to make exactly 50 mL. Pipet 200 μ L each of these solutions in the test tube with glass stopper, add exactly 3 mL of pyridine and exactly 2 mL of a solution of 2,4,6-trinitrobenzenesulfonic acid (1 in 100), stopper tightly, and heat in a water bath at 70°C for 30 minutes. After cooling, add exactly 2 mL each of acetic acid (100), and use these solutions as the sample solution and standard solution, respectively. Perform the test with exactly 20 μ L each of these solutions as directed under Liquid Chromatography <2.01> according to the following conditions, and determine the heights, H_T and H_S , of the peak of amikacin derivative in each solution.

$$\begin{aligned} &\text{Amount } [\mu\text{g (potency)}] \text{ of amikacin (C}_{22}\text{H}_{43}\text{N}_5\text{O}_{13}) \\ &= M_S \times H_T/H_S \times 1000 \end{aligned}$$

M_S : Amount [mg (potency)] of Amikacin Sulfate RS taken

Operating conditions—

Detector: An ultraviolet absorption photometer (wavelength: 340 nm).

Column: A stainless steel column 4.6 mm in inside diameter and 25 cm in length, packed with octadecylsilylated silica gel for liquid chromatography (5 μ m in particle diameter).

Column temperature: A constant temperature of about 35°C.

Mobile phase: Dissolve 2.72 g of potassium dihydrogenphosphate in 800 mL of water, adjust to pH 6.5 with a solution of potassium hydroxide (1 in 40), and add water to make 1000 mL. To 280 mL of this solution add 720 mL of methanol, and mix.

Flow rate: Adjust so that the retention time of amikacin derivative is about 9 minutes.

System suitability—

System performance: Dissolve about 5 mg (potency) of Amikacin Sulfate and about 5 mg (potency) of Kanamycin Sulfate in 5 mL of water. Transfer 200 μ L of this solution in a glass-stoppered test tube, add 3 mL of pyridine and 2 mL of a solution of 2,4,6-trinitrobenzenesulfonic acid (1 in 100), stopper tightly, heat in a water bath at 70°C for 30 minutes. After cooling, add 2 mL of acetic acid (100). When the procedure is run with 20 μ L of this solution under the above operating conditions, amikacin derivative and kanamycin derivative are eluted in this order with the resolution between

these peaks being not less than 5.

System repeatability: When the test is repeated 6 times with 20 μ L of the standard solution under the above operating conditions, the relative standard deviation of the ratios of the peak height of amikacin derivative is not more than 2.0%.

Containers and storage Containers—Hermetic containers.

Amikacin Sulfate Injection

アミカシン硫酸塩注射液

Amikacin Sulfate Injection is an aqueous injection.

It contains not less than 90.0% and not more than 115.0% of the labeled potency of amikacin (C₂₂H₄₃N₅O₁₃: 585.60).

Method of preparation Prepare as directed under Injections, with Amikacin Sulfate.

Description Amikacin Sulfate Injection occurs as a colorless or pale yellow clear liquid.

Identification To a volume of Amikacin Sulfate Injection, equivalent to 0.1 g (potency) of Amikacin Sulfate, add water to make 4 mL, and use this solution as the sample solution. Separately, dissolve 25 mg (potency) of Amikacin Sulfate RS in 1 mL of water, and use this solution as the standard solution. Then, proceed as directed in the Identification (2) under Amikacin Sulfate.

Osmotic pressure ratio Being specified separately when the drug is granted approval based on the Law.

pH <2.54> 6.0 – 7.5

Bacterial endotoxins <4.01> Less than 0.50 EU/mg (potency).

Extractable volume <6.05> It meets the requirement.

Foreign insoluble matter <6.06> Perform the test according to Method 1: it meets the requirement.

Insoluble particulate matter <6.07> It meets the requirement.

Sterility <4.06> Perform the test according to the Membrane filtration method: it meets the requirement.

Assay Take exactly a volume of Amikacin Sulfate Injection, equivalent to about 0.1 g (potency) of Amikacin Sulfate, and add water to make exactly 100 mL. Separately, weigh accurately an amount of Amikacin Sulfate RS, equivalent to about 50 mg (potency), and add water to make exactly 50 mL. Take exactly 200 μ L each of these solutions into stoppered test tubes, then proceed as directed in the Assay under Amikacin Sulfate.

$$\begin{aligned} &\text{Amount [mg (potency)] of amikacin (C}_{22}\text{H}_{43}\text{N}_5\text{O}_{13}) \\ &= M_S \times H_T/H_S \times 2 \end{aligned}$$

M_S : Amount [mg (potency)] of Amikacin Sulfate RS taken

Containers and storage Containers—Hermetic containers.

Amikacin Sulfate for Injection

注射用アミカシン硫酸塩

Amikacin Sulfate for Injection is a preparation for injection, which is dissolved before use.

It contains not less than 90.0% and not more than 115.0% of the labeled potency of amikacin ($C_{22}H_{43}N_5O_{13}$; 585.60).

Method of preparation Prepare as directed under Injections, with Amikacin Sulfate.

Description Amikacin Sulfate for Injection occurs as white to yellow-white masses or powder.

Identification Dissolve an amount of Amikacin Sulfate for Injection, equivalent to 25 mg (potency) of Amikacin Sulfate, in 1 mL of water, and use this solution as the sample solution. Separately, dissolve 25 mg (potency) of Amikacin Sulfate RS in 1 mL of water, and use this solution as the standard solution. Then, proceed as directed in the Identification (2) under Amikacin Sulfate.

Osmotic pressure ratio Being specified separately when the drug is granted approval based on the Law.

pH <2.54> Dissolve an amount of Amikacin Sulfate for Injection, equivalent to 0.1 g (potency) of Amikacin Sulfate, in 10 mL of water: the pH of this solution is 6.0 to 7.5.

Purity Clarity and color of solution—Dissolve an amount of Amikacin Sulfate for Injection, equivalent to 0.5 g (potency) of Amikacin Sulfate, in 5 mL of water: the solution is clear, and the absorbance at 405 nm of the solution determined as directed under Ultraviolet-visible Spectrophotometry <2.24> is not more than 0.15.

Loss on drying <2.41> Not more than 4.0% (1 g, in vacuum, 60°C, 3 hours).

Bacterial endotoxins <4.01> Less than 0.50 EU/mg (potency).

Uniformity of dosage units <6.02> It meets the requirement of the Mass variation test.

Foreign insoluble matter <6.06> Perform the test according to Method 2: it meets the requirement.

Insoluble particulate matter <6.07> It meets the requirement.

Sterility <4.06> Perform the test according to the Membrane filtration method: it meets the requirement.

Assay Weigh accurately the mass of the content of not less than 10 Amikacin Sulfate for Injection. Weigh accurately a portion of the content, equivalent to about 50 mg (potency) of Amikacin Sulfate, dissolve in water to make exactly 50 mL. Separately, weigh accurately an amount of Amikacin Sulfate RS, equivalent to about 50 mg (potency), and dissolve in water to make exactly 50 mL. Transfer exactly 200 μ L each of these solutions to separate glass stoppered tubes, and proceed as directed in the Assay under Amikacin Sulfate.

$$\begin{aligned} & \text{Amount [mg (potency)] of amikacin } (C_{22}H_{43}N_5O_{13}) \\ & = M_S \times H_T/H_S \end{aligned}$$

M_S : Amount [mg (potency)] of Amikacin Sulfate RS taken

Containers and storage Containers—Hermetic containers.

Aminophylline Hydrate

アミノフィリン水和物

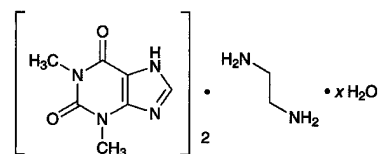

$C_{14}H_{16}N_8O_4 \cdot C_2H_8N_2 \cdot xH_2O$
1,3-Dimethyl-1H-purine-2,6(3H,7H)-dione
hemi(ethane-1,2-diamine) hydrate
[76970-41-7, monohydrate]

Aminophylline Hydrate contains not less than 84.0% and not more than 86.0% of theophylline ($C_7H_8N_4O_2$; 180.16), and not less than 14.0% and not more than 15.0% of ethylenediamine ($C_2H_8N_2$; 60.10), calculated on the anhydrous basis.

Description Aminophylline Hydrate occurs as white to pale yellow, granules or powder. It is odorless or slightly ammonia-like odor, and has a bitter taste.

It is soluble in water, slightly soluble in methanol, and practically insoluble in ethanol (95) and in diethyl ether.

To 1 g of Aminophylline Hydrate add 5 mL of water, and shake: it dissolves almost completely. Separation of crystals begins in 2 to 3 minutes, and these crystals dissolve on the addition of a small amount of ethylenediamine.

It is gradually affected by light, and gradually loses ethylenediamine in air.

Identification (1) Dissolve 0.75 g of Aminophylline Hydrate in 30 mL of water, and use this solution as the sample solution. To 20 mL of the sample solution add 1 mL of dilute hydrochloric acid: a precipitate is gradually formed. Filter the precipitate, recrystallize from water, and dry at 105°C for 1 hour: the crystals so obtained melt <2.60> between 271°C and 275°C.

(2) Dissolve 0.1 g of the crystals obtained in (1) in 50 mL of water, and to 2 mL of this solution add tannic acid TS dropwise: a white precipitate is produced, and this precipitate dissolves upon dropwise addition of tannic acid TS.

(3) To 0.01 g of the crystals obtained in (1) add 10 drops of hydrogen peroxide TS and 1 drop of hydrochloric acid, and evaporate on a water bath to dryness: the residue shows a yellow-red color. Invert the dish containing the residue over a vessel containing 2 to 3 drops of ammonia TS: the color of the residue changes to red-purple, which is destroyed on the addition of 2 to 3 drops of sodium hydroxide TS.

(4) Dissolve 0.01 g of the crystals obtained in (1) in 5 mL of water, add 3 mL of ammonia-ammonium chloride buffer solution (pH 8.0) and 1 mL of copper (II) sulfate-pyridine TS, and mix. Add 5 mL of chloroform to the mixture, and shake: the chloroform layer develops a green color.

(5) To 5 mL of the sample solution obtained in (1) add 2 drops of copper (II) sulfate TS: a purple color develops. Add 1 mL of copper (II) sulfate TS: the color changes to blue, and green precipitates are formed on standing.

pH <2.54> Dissolve 1.0 g of Aminophylline Hydrate in 25 mL of water: the pH of the solution is between 8.0 and 9.5.

Purity (1) Clarity and color of solution—Dissolve 1.0 g

of Aminophylline Hydrate in 10 mL of hot water: the solution is clear and colorless to pale yellow.

(2) Heavy metals <1.07>—Proceed with 1.0 g of Aminophylline Hydrate according to Method 2, and perform the test. Prepare the control solution with 2.0 mL of Standard Lead Solution (not more than 20 ppm).

Water <2.48> Not more than 7.9% (0.3 g, direct titration).

Residue on ignition <2.44> Not more than 0.1% (1 g).

Assay (1) Theophylline—Weigh accurately about 0.25 g of Aminophylline Hydrate, and dissolve in 50 mL of water and 8 mL of ammonia TS by gentle warming on a water bath. Add exactly 20 mL of 0.1 mol/L silver nitrate VS, warm on a water bath for 15 minutes, allow to stand between 5°C and 10°C for 20 minutes, collect the precipitate by suction, and wash with three 10-mL portions of water. Combine the filtrate and washings, and add dilute nitric acid to make neutral. Add 3 mL of dilute nitric acid, and titrate <2.50> the excess silver nitrate with 0.1 mol/L ammonium thiocyanate VS (indicator: 2 mL of ammonium iron (III) sulfate TS). Perform a blank determination in the same manner.

Each mL of 0.1 mol/L silver nitrate VS
= 18.02 mg of $C_7H_8N_4O_2$

(2) Ethylenediamine—Weigh accurately about 0.5 g of Aminophylline Hydrate, dissolve in 30 mL of water, and titrate <2.50> with 0.1 mol/L hydrochloric acid VS (indicator: 3 drops of bromophenol blue TS).

Each mL of 0.1 mol/L hydrochloric acid VS
= 3.005 mg of $C_2H_8N_2$

Containers and storage Containers—Tight containers.

Storage—Light-resistant.

Aminophylline Injection

アミノフィリン注射液

Aminophylline Injection is an aqueous injection.

It contains not less than 75.0% and not more than 86.0% of the labeled amount of theophylline ($C_7H_8N_4O_2$: 180.16), and not less than 13.0% and not more than 20.0% of ethylenediamine ($C_2H_8N_2$: 60.10).

The concentration of Aminophylline Injection is expressed as the quantity of aminophylline dihydrate ($C_{16}H_{24}N_{10}O_4 \cdot 2H_2O$: 456.46).

Method of preparation Prepare as directed under Injections, with Aminophylline Hydrate. It may be prepared with Theophylline and its equivalent Ethylenediamine, instead of Aminophylline Hydrate.

It may contain not more than 60 mg of Ethylenediamine as a stabilizer for each g of Aminophylline Hydrate.

Description Aminophylline Injection is a clear and colorless liquid. It has a slightly bitter taste.

It gradually changes in color by light.

pH: 8.0 – 10.0

Identification To a volume of Aminophylline Injection, equivalent to 0.75 g of Aminophylline Hydrate, add water to make 30 mL. Proceed with this solution as directed in the Identification under Aminophylline Hydrate.

Bacterial endotoxins <4.01> Less than 0.6 EU/mg.

Extractable volume <6.05> It meets the requirement.

Foreign insoluble matter <6.06> Perform the test according to Method 1: it meets the requirement.

Insoluble particulate matter <6.07> It meets the requirement.

Sterility <4.06> Perform the test according to the Membrane filtration method: it meets the requirement.

Assay (1) Theophylline—Pipet a volume of Aminophylline Injection, equivalent to about 39.4 mg of theophylline ($C_7H_8N_4O_2$) (about 50 mg of Aminophylline Hydrate), add water to make exactly 50 mL, and use this solution as the sample solution. Separately, weigh accurately about 40 mg of theophylline for assay, previously dried at 105°C for 4 hours, dissolve in water to make exactly 50 mL, and use this solution as the standard solution. Perform the test with exactly 5 μ L each of the sample solution and standard solution as directed under Liquid Chromatography <2.01> according to the following conditions, and determine the peak areas, A_T and A_S , of theophylline in each solution.

$$\begin{aligned} &\text{Amount (mg) of theophylline (} C_7H_8N_4O_2 \text{)} \\ &= M_S \times A_T / A_S \end{aligned}$$

M_S : Amount (mg) of theophylline for assay taken

Operating conditions—

Detector: An ultraviolet absorption photometer (wavelength: 270 nm).

Column: A stainless steel column 6 mm in inside diameter and 15 cm in length, packed with octadecylsilanized silica gel for liquid chromatography (5 μ m in particle diameter).

Column temperature: A constant temperature of about 40°C.

Mobile phase: A mixture of diluted acetic acid (100) (1 in 100) and methanol (4:1).

Flow rate: Adjust so that the retention time of theophylline is about 5 minutes.

System suitability—

System performance: When the procedure is run with 5 μ L of the standard solution under the above operating conditions, the number of theoretical plates and the symmetry factor of the peak of theophylline are not less than 3000 and not more than 1.5, respectively.

System repeatability: When the test is repeated 6 times with 5 μ L of the standard solution under the above operating conditions, the relative standard deviation of the peak area of theophylline is not more than 1.0%.

(2) Ethylenediamine—To an accurately measured volume of Aminophylline Injection, equivalent to about 30 mg of ethylenediamine ($C_2H_8N_2$) (about 0.2 g of Aminophylline Hydrate), add water to make 30 mL, and titrate <2.50> with 0.1 mol/L hydrochloric acid VS (indicator: 2 to 3 drops of bromophenol blue TS).

Each mL of 0.1 mol/L hydrochloric acid VS
= 3.005 mg of $C_2H_8N_2$

Containers and storage Containers—Hermetic containers. Plastic containers for aqueous injections may be used.

Storage—Light-resistant.

Amiodarone Hydrochloride

アミオダロン塩酸塩

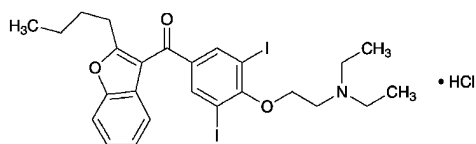

$C_{25}H_{29}I_2NO_3 \cdot HCl$: 681.77
(2-Butylbenzofuran-3-yl) {4-[2-(diethylamino)ethoxy]-3,5-diiodophenyl} methanone monohydrochloride
[19774-82-4]

Amiodarone Hydrochloride, when dried, contains not less than 98.5% and not more than 101.0% of amiodarone hydrochloride ($C_{25}H_{29}I_2NO_3 \cdot HCl$).

Description Amiodarone Hydrochloride occurs as a white to pale yellow-white crystalline powder.

It is very soluble in water at 80°C, freely soluble in dichloromethane, soluble in methanol, sparingly soluble in ethanol (95), and very slightly soluble in water.

Melting point: about 161°C (with decomposition).

Identification (1) Determine the absorption spectrum of a solution of Amiodarone Hydrochloride in ethanol (95) (1 in 100,000) as directed under Ultraviolet-visible Spectrophotometry <2.24>, and compare the spectrum with the Reference Spectrum: both spectra exhibit similar intensities of absorption at the same wavelengths.

(2) Determine the infrared absorption spectrum of Amiodarone Hydrochloride as directed in the potassium bromide disk method under Infrared Spectrophotometry <2.25>, and compare the spectrum with the Reference Spectrum: both spectra exhibit similar intensities of absorption at the same wave numbers.

(3) To 0.1 g of Amiodarone Hydrochloride add 10 mL of water, dissolve by warming at 80°C, and cool: the solution responds to Qualitative Tests <1.09> (2) for chloride.

pH <2.54> To 1.0 g of Amiodarone Hydrochloride add 20 mL of freshly boiled and cooled water, dissolve by warming at 80°C, and cool: the pH of this solution is between 3.2 and 3.8.

Purity (1) Clarity and color of solution—Dissolve 0.5 g of Amiodarone Hydrochloride in 10 mL of methanol: the solution is clear, and is not more colored than the following control solutions (1) and (2).

Control solution (1): To a mixture of 1.0 mL of Cobalt (II) Chloride CS, 2.4 mL of Iron (III) Chloride CS and 0.4 mL of Copper (II) Sulfate CS, add diluted hydrochloric acid (1 in 40) to make 10.0 mL. To 2.5 mL of this solution add diluted hydrochloric acid (1 in 40) to make 20 mL.

Control solution (2): To 3.0 mL of a mixture of 0.2 mL of Cobalt (II) Chloride CS, 9.6 mL of Iron (III) Chloride CS and 0.2 mL of Copper (II) Sulfate CS, add diluted hydrochloric acid (1 in 40) to make 100 mL.

(2) Iodine—To 1.50 g of Amiodarone Hydrochloride add 40 mL of water, dissolve by warming at 80°C, cool, add water to make exactly 50 mL, and use this solution as the sample stock solution. Pipet 15 mL of this solution, add exactly 1 mL of 0.1 mol/L hydrochloric acid TS and exactly 1 mL of a solution of potassium iodate (107 in 10,000), add water to make exactly 20 mL, and use this solution as the sample solution. Separately, pipet 15 mL of the sample stock

solution, add exactly 1 mL of 0.1 mol/L hydrochloric acid TS, exactly 1 mL of a solution of potassium iodide (441 in 5,000,000) and exactly 1 mL of a solution of potassium iodate (107 in 10,000), add water to make exactly 20 mL, and use this solution as the standard solution. Separately, pipet 15 mL of the sample stock solution, add exactly 1 mL of 0.1 mol/L hydrochloric acid TS, add water to make exactly 20 mL, and use this solution as the control solution. Allow the sample solution, standard solution and control solution to stand in a dark place for 4 hours. Perform the test with the sample solution and standard solution as directed under Ultraviolet-visible Spectrophotometry <2.24>, using the control solution as the blank: the absorbance of the sample solution at 420 nm is not larger than 1/2 times the absorbance of the standard solution.

(3) Heavy metals <1.07>—Proceed with 1.0 g of Amiodarone Hydrochloride according to Method 4, and perform the test. Prepare the control solution with 2.0 mL of Standard Lead Solution (not more than 20 ppm).

(4) Related substance 1—Dissolve 0.5 g of Amiodarone Hydrochloride in 5 mL of dichloromethane, and use this solution as the sample solution. Separately, dissolve 10 mg of 2-chloroethyl diethylamine hydrochloride in 50 mL of dichloromethane, and use this solution as the standard solution. Perform the test with these solutions as directed under Thin-layer Chromatography <2.03>. Spot 5 μ L each of the sample solution and standard solution on a plate of silica gel with fluorescent indicator for thin-layer chromatography. Develop the plate with a mixture of dichloromethane, methanol and formic acid (17:2:1) to a distance of about 15 cm, and air-dry the plate. Spray evenly bismuth subnitrate TS and then hydrogen peroxide TS: the spot obtained from the sample solution corresponding to the spot from the standard solution is not more intense than the spot from the standard solution.

(5) Related substance 2—Dissolve 0.125 g of Amiodarone Hydrochloride in 25 mL of a mixture of water and acetonitrile for liquid chromatography (1:1), and use this solution as the sample solution. Pipet 2 mL of the sample solution, and add a mixture of water and acetonitrile for liquid chromatography (1:1) to make exactly 50 mL. Pipet 1 mL of this solution, add a mixture of water and acetonitrile for liquid chromatography (1:1) to make exactly 20 mL, and use this solution as the standard solution. Perform the test with exactly 10 μ L each of the sample solution and standard solution as directed under Liquid Chromatography <2.01> according to the following conditions. Determine each peak area by the automatic integration method: the area of the peak other than amiodarone obtained from the sample solution is not larger than the peak area of amiodarone from the standard solution, and the total area of the peaks other than amiodarone from the sample solution is not larger than 2.5 times the peak area of amiodarone from the standard solution.

Operating conditions—

Detector: An ultraviolet absorption photometer (wavelength: 240 nm).

Column: A stainless steel column 4.6 mm in inside diameter and 15 cm in length, packed with octadecylsilanized silica gel for liquid chromatography (5 μ m in particle diameter).

Column temperature: A constant temperature of about 30°C.

Mobile phase: To 800 mL of water add 3.0 mL of acetic acid (100), adjust the pH to 4.95 with ammonia solution (28), and add water to make 1000 mL. To 300 mL of this solution add 400 mL of acetonitrile for liquid chromatography and 300 mL of methanol for liquid chromatography.

Flow rate: Adjust so that the retention time of amiodarone is about 24 minutes.

Time span of measurement: About 2 times as long as the retention time of amiodarone.

System suitability—

Test for required detectability: Pipet 5 mL of the standard solution, and add a mixture of water and acetonitrile for liquid chromatography (1:1) to make exactly 25 mL. Confirm that the peak area of amiodarone obtained with 10 μ L of this solution is equivalent to 14 to 26% of that with 10 μ L of the standard solution.

System performance: When the procedure is run with 10 μ L of the standard solution under the above operating conditions, the number of theoretical plates and the symmetry factor of the peak of amiodarone are not less than 5000 and not more than 1.5, respectively.

System repeatability: When the test is repeated 6 times with 10 μ L of the standard solution under the above operating conditions, the relative standard deviation of the peak area of amiodarone is not more than 1.0%.

Loss on drying <2.41> Not more than 0.5% (1 g, reduced pressure not exceeding 0.3 kPa, 50°C, 4 hours).

Residue on ignition <2.44> Not more than 0.1% (1 g).

Assay Weigh accurately about 0.6 g of Amiodarone Hydrochloride, previously dried, dissolve in 40 mL of a mixture of acetic anhydride and acetic acid (100) (3:1), and titrate <2.50> with 0.1 mol/L perchloric acid VS (potentiometric titration). Perform a blank determination in the same manner, and make any necessary correction.

Each mL of 0.1 mol/L perchloric acid VS
= 68.18 mg of $C_{25}H_{29}I_2NO_3 \cdot HCl$

Containers and storage Containers—Tight containers.
Storage—Light-resistant.

Amiodarone Hydrochloride Tablets

アミオダロン塩酸塩錠

Amiodarone Hydrochloride Tablets contain not less than 93.0% and not more than 107.0% of the labeled amount of amiodarone hydrochloride ($C_{25}H_{29}I_2NO_3 \cdot HCl$; 681.77).

Method of preparation Prepare as directed under Tablets, with Amiodarone Hydrochloride.

Identification To 1 mL of the sample stock solution obtained in the Assay add the mobile phase to make 50 mL. Determine the absorption spectrum of this solution as directed under Ultraviolet-visible Spectrophotometry <2.24>: it exhibits a maximum between 239 nm and 243 nm.

Uniformity of dosage units <6.02> Perform the Mass variation test, or the Content uniformity test according to the following method: it meets the requirement.

To 1 tablet of Amiodarone Hydrochloride Tablets add 160 mL of the mobile phase, sonicate for 10 minutes, add the mobile phase to make exactly 200 mL, and centrifuge. Pipet V mL of the supernatant liquid, equivalent to about 1 mg of amiodarone hydrochloride ($C_{25}H_{29}I_2NO_3 \cdot HCl$), add the mobile phase to make exactly 50 mL, and use this solution as the sample solution. Separately, weigh accurately about 25 mg of amiodarone hydrochloride for assay, previously dried at 50°C for 4 hours under reduced pressure not

exceeding 0.3 kPa, and dissolve in the mobile phase to make exactly 50 mL. Pipet 2 mL of this solution, add the mobile phase to make exactly 50 mL, and use this solution as the standard solution. Perform the test with exactly 10 μ L each of the sample solution and standard solution as directed under Liquid Chromatography <2.01> according to the following conditions, and determine the peak areas, A_T and A_S , of amiodarone in each solution.

Amount (mg) of amiodarone hydrochloride
($C_{25}H_{29}I_2NO_3 \cdot HCl$)
= $M_S \times A_T / A_S \times 8 / V$

M_S : Amount (mg) of amiodarone for assay taken

Operating conditions—

Proceed as directed in the operating conditions in the Assay.

System suitability—

System performance: When the procedure is run with 10 μ L of the standard solution under the above operating conditions, the number of theoretical plates and the symmetry factor of the peak of amiodarone are not less than 5000 and not more than 1.5, respectively.

System repeatability: When the test is repeated 6 times with 10 μ L of the standard solution under the above operating conditions, the relative standard deviation of the peak area of amiodarone is not more than 1.0%.

Dissolution <6.10> When the test is performed at 50 revolutions per minute according to the Paddle method, using 900 mL of acetic acid-sodium acetate buffer solution (pH 4.0) as the dissolution medium, the dissolution rate in 30 minutes of Amiodarone Hydrochloride Tablets is not less than 80%.

Start the test with 1 tablet of Amiodarone Hydrochloride Tablets, withdraw not less than 20 mL of the medium at the specified minute after starting the test, and filter through a membrane filter with a pore size not exceeding 0.45 μ m. Discard not less than 10 mL of the first filtrate, pipet V mL of the subsequent filtrate, add exactly V mL of methanol, then add a mixture of the dissolution medium and methanol (1:1) to make exactly V' mL so that each mL contains about 11 μ g of amiodarone hydrochloride ($C_{25}H_{29}I_2NO_3 \cdot HCl$), and use this solution as the sample solution. Separately, weigh accurately about 28 mg of amiodarone hydrochloride for assay, previously dried at 50°C for 4 hours under reduced pressure not exceeding 0.3 kPa, and dissolve in methanol to make exactly 50 mL. Pipet 2 mL of this solution, add exactly 2 mL of the dissolution medium, then add a mixture of the dissolution medium and methanol (1:1) to make exactly 100 mL, and use this solution as the standard solution. Determine the absorbances, A_T and A_S , of the sample solution and standard solution at 241 nm as directed under Ultraviolet-visible Spectrophotometry <2.24>, using a mixture of the dissolution medium and methanol (1:1) as the blank.

Dissolution rate (%) with respect to the labeled amount of amiodarone hydrochloride ($C_{25}H_{29}I_2NO_3 \cdot HCl$)
= $M_S \times A_T / A_S \times V' / V \times 1 / C \times 36$

M_S : Amount (mg) of amiodarone hydrochloride for assay taken

C : Labeled amount (mg) of amiodarone hydrochloride ($C_{25}H_{29}I_2NO_3 \cdot HCl$) in 1 tablet

Assay Weigh accurately the mass of not less than 20 Amiodarone Hydrochloride Tablets, and powder. Weigh accurately a portion of the powder, equivalent to about 50 mg of amiodarone hydrochloride ($C_{25}H_{29}I_2NO_3 \cdot HCl$), add 80 mL of the mobile phase, sonicate for 10 minutes, and add the

mobile phase to make exactly 100 mL. Centrifuge this solution, and use the supernatant liquid as the sample stock solution. Pipet 2 mL of the stock solution, add exactly 2 mL of the internal standard solution, add the mobile phase to make 50 mL, and use this solution as the sample solution. Separately, weigh accurately 25 mg of amiodarone hydrochloride for assay, previously dried at 50°C for 4 hours under reduced pressure not exceeding 0.3 kPa, and dissolve in the mobile phase to make exactly 50 mL. Pipet 2 mL of this solution, add exactly 2 mL of the internal standard solution, add the mobile phase to make 50 mL, and use this solution as the standard solution. Perform the test with 10 μ L each of the sample solution and standard solution as directed under Liquid Chromatography <2.01> according to the following conditions, and calculate the ratios, Q_T and Q_S , of the peak area of amiodarone to that of the internal standard.

$$\begin{aligned} & \text{Amount (mg) of amiodarone hydrochloride} \\ & (C_{25}H_{29}I_2NO_3 \cdot HCl) \\ & = M_S \times Q_T / Q_S \times 2 \end{aligned}$$

M_S : Amount (mg) of amiodarone hydrochloride for assay taken

Internal standard solution—A solution of chlorhexidine hydrochloride in the mobile phase (1 in 2500).

Operating conditions—

Detector: An ultraviolet absorption photometer (wavelength: 242 nm).

Column: A stainless steel column 4 mm in inside diameter and 15 cm in length, packed with octadecylsilanized silica gel for liquid chromatography (5 μ m in particle diameter).

Column temperature: A constant temperature of about 50°C.

Mobile phase: A mixture of acetonitrile for liquid chromatography, a solution of sodium laurylsulfate (1 in 50) and phosphoric acid (750:250:1).

Flow rate: Adjust so that the retention time of amiodarone is about 7 minutes.

System suitability—

System performance: When the procedure is run with 10 μ L of the standard solution under the above operating conditions, the internal standard and amiodarone are eluted in this order with the resolution between these peaks being not less than 5.

System repeatability: When the test is repeated 6 times with 10 μ L of the standard solution under the above operating conditions, the relative standard deviation of the ratio of the peak area of amiodarone to that of the internal standard is not more than 1.0%.

Containers and storage Containers—Tight containers.

Storage—Light-resistant.

Amitriptyline Hydrochloride

アミトリプチリン塩酸塩

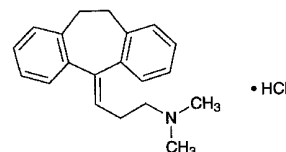

$C_{20}H_{23}N \cdot HCl$: 313.86

3-(10,11-Dihydro-5H-dibenzo[*a,d*]cyclohepten-5-ylidene)-*N,N*-dimethylpropylamine monohydrochloride [549-18-8]

Amitriptyline Hydrochloride, when dried, contains not less than 99.0% of amitriptyline hydrochloride ($C_{20}H_{23}N \cdot HCl$).

Description Amitriptyline Hydrochloride occurs as colorless crystals or a white to pale yellow crystalline powder. It has a bitter taste and a numbing effect.

It is freely soluble in water, in ethanol (95) and in acetic acid (100), soluble in acetic anhydride, and practically insoluble in diethyl ether.

The pH of a solution of 1.0 g of Amitriptyline Hydrochloride in 20 mL of water is between 4.0 and 5.0.

Identification (1) Dissolve 5 mg of Amitriptyline Hydrochloride in 3 mL of sulfuric acid: a red color develops. Add 5 drops of potassium dichromate TS to this solution: it turns dark brown.

(2) Acidify 1 mL of a solution of Amitriptyline Hydrochloride (1 in 500) with 0.5 mL of dilute nitric acid, and add 1 drop of silver nitrate TS: a white, opalescent precipitate is produced.

(3) Determine the absorption spectrum of a solution of Amitriptyline Hydrochloride (1 in 100,000) as directed under Ultraviolet-visible Spectrophotometry <2.24>, and compare the spectrum with the Reference Spectrum or the spectrum of a solution of Amitriptyline Hydrochloride RS prepared in the same manner as the sample solution: both spectra exhibit similar intensities of absorption at the same wavelengths.

Melting point <2.60> 195 – 198°C

Purity (1) Clarity and color of solution—Dissolve 1.0 g of Amitriptyline Hydrochloride in 20 mL of water: the solution is clear and colorless.

(2) Heavy metals <1.07>—Proceed with 2.0 g of Amitriptyline Hydrochloride according to Method 2, and perform the test. Prepare the control solution with 2.0 mL of Standard Lead Solution (not more than 10 ppm).

Loss on drying <2.41> Not more than 0.5% (1 g, 105°C, 2 hours).

Residue on ignition <2.44> Not more than 0.1% (1 g).

Assay Weigh accurately about 0.5 g of Amitriptyline Hydrochloride, previously dried, dissolve in 50 mL of a mixture of acetic anhydride and acetic acid (100) (7:3), and titrate <2.50> with 0.1 mol/L perchloric acid VS (potentiometric titration). Perform a blank determination in the same manner, and make any necessary correction.

$$\begin{aligned} & \text{Each mL of 0.1 mol/L perchloric acid VS} \\ & = 31.39 \text{ mg of } C_{20}H_{23}N \cdot HCl \end{aligned}$$

Containers and storage Containers—Tight containers.

Storage—Light-resistant.

Amitriptyline Hydrochloride Tablets

アミトリプチリン塩酸塩錠

Amitriptyline Hydrochloride Tablets contain not less than 90.0% and not more than 110.0% of the labeled amount of amitriptyline hydrochloride ($C_{20}H_{23}N.HCl$; 313.86).

Method of preparation Prepare as directed under Tablets, with Amitriptyline Hydrochloride.

Identification (1) Weigh a quantity of powdered Amitriptyline Hydrochloride Tablets, equivalent to 0.1 g of Amitriptyline Hydrochloride. Add 10 mL of chloroform, shake thoroughly, and filter. Evaporate the filtrate on a water bath to about 2 mL, add diethyl ether until turbidity is produced, and allow to stand. Filter the crystals formed through a glass filter (G4), and proceed as directed in the Identification (1) and (2) under Amitriptyline Hydrochloride.

(2) Determine the absorption spectrum of a solution of the crystals obtained in (1) (1 in 100,000) as directed under Ultraviolet-visible Spectrophotometry <2.24>: it exhibits a maximum between 238 nm and 240 nm, and a minimum between 228 nm and 230 nm.

Uniformity of dosage units <6.02> Perform the test according to the following method: it meets the requirement of the Content uniformity test.

To 1 tablet of Amitriptyline Hydrochloride Tablets add 50 mL of diluted methanol (1 in 2), shake to disintegrate the tablet, then add diluted methanol (1 in 2) to make exactly 100 mL, and filter. Discard the first 20 mL of the filtrate, pipet V mL of the subsequent filtrate, add methanol to make exactly V' mL so that each mL contains about 10 μ g of amitriptyline hydrochloride ($C_{20}H_{23}N.HCl$), and use this solution as the sample solution. Then, proceed as directed in the Assay.

Amount (mg) of amitriptyline hydrochloride ($C_{20}H_{23}N.HCl$)
 $= M_S \times A_T/A_S \times V'/V \times 1/20$

M_S : Amount (mg) of Amitriptyline Hydrochloride RS taken

Dissolution <6.10> When the test is performed at 50 revolutions per minute according to the Paddle method, using 900 mL of 2nd fluid for dissolution test as the dissolution medium, the dissolution rate in 60 minutes of Amitriptyline Hydrochloride Tablets is not less than 70%.

Start the test with 1 tablet of Amitriptyline Hydrochloride Tablets, withdraw not less than 20 mL of the medium at the specified minute after starting the test, and filter through a membrane filter with a pore size not exceeding 0.8 μ m. Discard not less than 10 mL of the first filtrate, pipet the subsequent V mL of the filtrate, add the dissolution medium to make exactly V' mL so that each mL contains about 11 μ g of amitriptyline hydrochloride ($C_{20}H_{23}N.HCl$), and use this solution as the sample solution. Separately, weigh accurately about 55 mg of Amitriptyline Hydrochloride RS, previously dried at 105°C for 2 hours, and dissolve in the dissolution medium to make exactly 250 mL. Pipet 5 mL of this solution, add the dissolution medium to make exactly 100 mL, and use this solution as the standard solution. Determine the absorbances, A_T and A_S , of the sample solution and stand-

ard solution at 239 nm as directed under Ultraviolet-visible Spectrophotometry <2.24>.

Dissolution rate (%) with respect to the labeled amount of amitriptyline hydrochloride ($C_{20}H_{23}N.HCl$)
 $= M_S \times A_T/A_S \times V'/V \times 1/C \times 18$

M_S : Amount (mg) of Amitriptyline Hydrochloride RS taken

C : Labeled amount (mg) of amitriptyline hydrochloride ($C_{20}H_{23}N.HCl$) in 1 tablet

Assay Weigh accurately and powder not less than 20 Amitriptyline Hydrochloride Tablets. Weigh accurately a portion of the powder, equivalent to about 20 mg of amitriptyline hydrochloride ($C_{20}H_{23}N.HCl$), and add 75 mL of diluted methanol (1 in 2). After shaking for 30 minutes, add diluted methanol (1 in 2) to make exactly 100 mL, and filter. Discard the first 20-mL portion of the filtrate, measure exactly the subsequent 5-mL portion, add methanol to make exactly 100 mL, and use this solution as the sample solution. Separately, weigh accurately about 20 mg of Amitriptyline Hydrochloride RS, previously dried at 105°C for 2 hours, and dissolve in diluted methanol (1 in 2) to make exactly 100 mL. Measure exactly 5 mL of this solution, add methanol to make exactly 100 mL, and use this solution as the standard solution. Determine the absorbances, A_T and A_S , of the sample solution and standard solution at 239 nm as directed under Ultraviolet-visible Spectrophotometry <2.24>, respectively.

Amount (mg) of amitriptyline hydrochloride ($C_{20}H_{23}N.HCl$)
 $= M_S \times A_T/A_S$

M_S : Amount (mg) of Amitriptyline Hydrochloride RS taken

Containers and storage Containers—Tight containers.

Amlexanox

アンレキサノクス

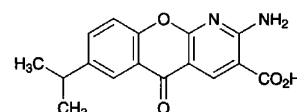

$C_{16}H_{14}N_2O_4$: 298.29
 2-Amino-7-(1-methylethyl)-5-oxo-5H-[1]benzopyrano[2,3-b]pyridine-3-carboxylic acid
 [68302-57-8]

Amlexanox, when dried, contains not less than 98.0% and not more than 102.0% of amlexanox ($C_{16}H_{14}N_2O_4$).

Description Amlexanox occurs as white to yellowish white, crystals or crystalline powder.

It is very slightly soluble in ethanol (99.5), and practically insoluble in water.

It dissolves in diluted sodium hydroxide TS (1 in 3).

Identification (1) Determine the absorption spectrum of a solution of Amlexanox in ethanol (99.5) (1 in 250,000) as directed under Ultraviolet-visible Spectrophotometry <2.24>, and compare the spectrum with the Reference Spectrum or the spectrum of a solution of Amlexanox RS prepared in the same manner as the sample solution: both spectra exhibit similar intensities of absorption at the same wavelengths.

(2) Determine the infrared absorption spectrum of Amlexanox as directed in the potassium bromide disk method under Infrared Spectrophotometry <2.25>, and compare the spectrum with the Reference Spectrum or the spectrum of Amlexanox RS: both spectra exhibit similar intensities of absorption at the same wave numbers.

Purity (1) Chloride <1.03>—Dissolve 1.0 g of Amlexanox in 20 mL of water and 10 mL of sodium hydroxide TS, add 15 mL of dilute nitric acid and water to make 50 mL, centrifuge, and then filter the supernatant liquid. To 25 mL of this filtrate add water to make 50 mL. Perform the test using this solution as the test solution. The control solution consists of 5 mL of sodium hydroxide TS, 7.5 mL of dilute nitric acid, 0.30 mL of 0.01 mol/L hydrochloric acid VS, and water added to make 50 mL (not more than 0.021%).

(2) Heavy metals <1.07>—Proceed with 1.0 g of Amlexanox according to Method 2, and perform the test. Prepare the control solution with 2.0 mL of Standard Lead Solution (not more than 20 ppm).

(3) Related substances—(i) Dissolve 30 mg of Amlexanox in 50 mL of the mobile phase, and use this solution as the sample solution. Pipet 1 mL of the sample solution, and add the mobile phase to make exactly 50 mL. Pipet 1 mL of this solution, add the mobile phase to make exactly 20 mL, and use this solution as the standard solution. Perform the test with exactly 10 μ L each of the sample solution and standard solution as directed under Liquid Chromatography <2.01> according to the following conditions. Determine each peak area of these solutions by the automatic integration method: the area of the peak other than amlexanox obtained from the sample solution is not larger than 2 times the peak area of amlexanox from the standard solution.

Operating conditions—

The detector, column, column temperature, mobile phase, and flow rate: Proceed as directed in the operating conditions in the Assay.

Time span of measurement: Until completion of the elution of amlexanox, beginning after the solvent peak.

System suitability—

System performance: Proceed as directed in the system suitability in the Assay.

Test for required detectability: Pipet 10 mL of the standard solution, and add the mobile phase to make exactly 100 mL. Confirm that the peak area of amlexanox obtained with 10 μ L of this solution is equivalent to 7 to 13% of that with 10 μ L of the standard solution.

System repeatability: When the test is repeated 6 times with 10 μ L of the standard solution under the above operating conditions, the relative standard deviation of the peak area of amlexanox is not more than 2.0%.

(ii) Dissolve 30 mg of Amlexanox in 50 mL of the mobile phase, and use this solution as the sample solution. Pipet 1 mL of the sample solution, and add the mobile phase to make exactly 50 mL. Pipet 1 mL of this solution, add the mobile phase to make exactly 20 mL, and use this solution as the standard solution. Perform the test with exactly 10 μ L each of the sample solution and standard solution as directed under Liquid Chromatography <2.01> according to the following conditions, and determine each peak area of these solutions by the automatic integration method: the area of the peak other than amlexanox obtained from the sample solution is not larger than 2 times the peak area of amlexanox from the standard solution.

Operating conditions—

Detector, column, and column temperature: Proceed as directed in the operating conditions in the Assay.

Mobile phase: Dissolve 7.2 g of disodium hydrogen phosphate dodecahydrate in water to make 1000 mL. Adjust the pH of this solution to 8.0 by adding a solution prepared by dissolving 3.1 g of sodium dihydrogen phosphate dihydrate in 1000 mL of water. To 400 mL of this solution add 600 mL of acetonitrile.

Flow rate: To 15 mL of a solution of benzophenone in the mobile phase (3 in 1,000,000) add the mobile phase to make 20 mL. Adjust so that the retention time of benzophenone is about 6.5 minutes when perform the test with 10 μ L of this solution under the conditions described above.

Time span of measurement: About 3 times as long as the retention time of benzophenone, beginning after the peak of amlexanox.

System suitability—

Test for required detectability: Pipet 5 mL of the standard solution, and add the mobile phase to make exactly 50 mL. Confirm that the peak area of amlexanox obtained with 10 μ L of this solution is equivalent to 7 to 13% of that with 10 μ L of the standard solution.

System performance: Pipet 1 mL of the sample solution, and add the mobile phase to make 100 mL. To 5 mL of this solution add 15 mL of the solution of benzophenone in the mobile phase (3 in 1,000,000). When perform the test with 10 μ L of this solution according to the above conditions, amlexanox and benzophenone are eluted in this order with the resolution between these peaks being not less than 10.

System repeatability: When the test is repeated 6 times with 10 μ L of the standard solution under the above operating conditions, the relative standard deviation of the peak area of amlexanox is not more than 2.0%.

(iii) The total amount of related substances, when calculated according to the following formula, is not more than 0.5%.

$$\begin{aligned} \text{Total amount (\%)} & \text{ of related substances} \\ & = \{(A_{T1}/A_{S1}) + (A_{T2}/A_{S2})\} \times 1/10 \end{aligned}$$

A_{T1} : Total area of the peaks other than amlexanox from the sample solution obtained in (i)

A_{T2} : Total area of the peaks other than amlexanox from the sample solution obtained in (ii)

A_{S1} : Peak area of amlexanox from the standard solution obtained in (i)

A_{S2} : Peak area of amlexanox from the standard solution obtained in (ii)

Loss on drying <2.41> Not more than 0.3% (1 g, 105°C, 2 hours).

Residue on ignition <2.44> Not more than 0.1% (1 g).

Assay Weigh accurately about 30 mg each of Amlexanox and Amlexanox RS, both dried, and dissolve them separately in the mobile phase to make exactly 50 mL. Pipet 5 mL each of these solutions, and add exactly 15 mL of the internal standard solution, and use these solutions as the sample solution and the standard solution, respectively. Perform the test with 10 μ L each of the sample solution and standard solution as directed under Liquid Chromatography <2.01> according to the following conditions, and calculate the ratios, Q_T and Q_S , of the peak area of amlexanox to that of the internal standard, respectively.

$$\text{Amount (mg) of amlexanox (C}_{16}\text{H}_{14}\text{N}_2\text{O}_4) = M_S \times Q_T/Q_S$$

M_S : Amount (mg) of Amlexanox RS taken

Internal standard solution—A solution of 3-nitroaniline in the mobile phase (1 in 4000).

Operating conditions—

Detector: An ultraviolet absorption photometer (wavelength: 254 nm).

Column: A stainless steel column 4.0 mm in inside diameter and 15 cm in length, packed with octadecylsilanized silica gel for liquid chromatography (5 μ m in particle diameter).

Column temperature: A constant temperature of about 25°C.

Mobile phase: Dissolve 17.9 g of disodium hydrogen phosphate dodecahydrate in water to make 1000 mL. Adjust the pH of this solution to 8.0 by adding a solution prepared by dissolving 7.8 g of sodium dihydrogen phosphate dihydrate in 1000 mL of water. To 760 mL of this solution add 240 mL of acetonitrile.

Flow rate: Adjust so that the retention time of amlexanox is about 10 minutes.

System suitability—

System performance: When the procedure is run with 10 μ L of the standard solution according to the above conditions, amlexanox and the internal standard are eluted in this order with the resolution between these peaks being not less than 2.0.

System repeatability: When the test is repeated 6 times with 10 μ L of the standard solution under the above conditions, the relative standard deviation of the ratio of the peak area of amlexanox to that of the internal standard is not more than 1.0%.

Containers and storage Containers—Well-closed containers.

Amlexanox Tablets

アンレキサノクス錠

Amlexanox Tablets contain not less than 93.0% and not more than 107.0% of the labeled amount of amlexanox (C₁₆H₁₄N₂O₄: 298.29).

Method of preparation Prepare as directed under Tablets, with Amlexanox.

Identification (1) Take an amount of powdered Amlexanox Tablets, equivalent to 10 mg of Amlexanox, add 100 mL of ethanol (99.5), shake vigorously, and filter. Pipet 1 mL of the filtrate, add 25 mL of ethanol (99.5), and use this solution as the sample solution. Determine the absorption spectrum of the sample solution as directed under Ultraviolet-visible Spectrophotometry <2.24>: it exhibits absorption maxima between 240 nm and 244 nm, between 285 nm and 289 nm, and between 341 nm and 352 nm.

(2) Observe the sample solution obtained in (1) under ultraviolet light (main wavelength: 365 nm): the solution shows a blue-white fluorescence.

Uniformity of dosage units <6.02> Perform the Mass variation test, or the Content uniformity test according to the following method: it meets the requirement.

Take 1 tablet of Amlexanox Tablets, add exactly 0.6 mL of the internal standard solution per 1 mg of amlexanox (C₁₆H₁₄N₂O₄), add the mobile phase to make exactly *V* mL so there is about 167 μ g of amlexanox (C₁₆H₁₄N₂O₄) per mL, disintegrate the tablet, and then shake vigorously for 5 minutes. Centrifuge this solution, and use the supernatant liquid as the sample solution. Separately, weigh accurately about 30 mg of Amlexanox RS, previously dried at 105°C for 2 hours, and dissolve in the mobile phase to make exactly

50 mL. Pipet 25 mL of this solution, add exactly 10 mL of the internal standard solution, add the mobile phase to make 100 mL, and use this solution as the standard solution. Then, proceed as directed in the Assay under Amlexanox.

$$\begin{aligned} &\text{Amount (mg) of amlexanox (C}_{16}\text{H}_{14}\text{N}_2\text{O}_4) \\ &= M_S \times Q_T/Q_S \times V/200 \end{aligned}$$

M_S: Amount (mg) of Amlexanox RS taken

Internal standard solution—A solution of 3-nitroaniline in the mobile phase (1 in 500).

Dissolution <6.10> When the test is performed at 50 revolutions per minute according to the Paddle method, using 900 mL of 2nd fluid for dissolution test as the dissolution medium, the dissolution rate in 45 minutes of Amlexanox Tablets is not less than 80%.

Start the test with 1 tablet of Amlexanox Tablets, withdraw not less than 20 mL of the medium at the specified minute after starting the test, and filter through a membrane filter with a pore size not exceeding 0.45 μ m. Discard not less than 10 mL of the first filtrate, pipet *V* mL of the subsequent filtrate, add the dissolution medium to make exactly *V'* mL so that each mL contains about 5.6 μ g of amlexanox (C₁₆H₁₄N₂O₄), and use this solution as the sample solution. Separately, weigh accurately about 28 mg of Amlexanox RS, previously dried at 105°C for 2 hours, and dissolve in 2 mL of dilute sodium hydroxide TS, add the dissolution medium to make exactly 50 mL. Pipet 1 mL of this solution, add the dissolution medium to make exactly 100 mL, and use this solution as the standard solution. Determine the absorbances, *A_T* and *A_S*, at 350 nm of the sample solution and standard solution as directed under Ultraviolet-visible Spectrophotometry <2.24>.

$$\begin{aligned} &\text{Dissolution rate (\%)} \text{ with respect to the labeled amount} \\ &\text{of amlexanox (C}_{16}\text{H}_{14}\text{N}_2\text{O}_4) \\ &= M_S \times A_T/A_S \times V'/V \times 1/C \times 18 \end{aligned}$$

M_S: Amount (mg) of Amlexanox RS taken

C: Labeled amount (mg) of amlexanox (C₁₆H₁₄N₂O₄) in 1 tablet

Assay Weigh accurately not less than 20 Amlexanox Tablets, and powder. Weigh accurately a portion of the powder, equivalent to about 15 mg of amlexanox (C₁₆H₁₄N₂O₄), add exactly 10 mL of the internal standard solution, add 80 mL of the mobile phase, shake vigorously for 5 minutes, and then add the mobile phase to make 100 mL. Centrifuge this solution, and use the supernatant liquid as the sample solution. Separately, weigh accurately about 30 mg of Amlexanox RS, previously dried at 105°C for 2 hours, and dissolve in the mobile phase to make exactly 50 mL. Pipet 25 mL of this solution, add exactly 10 mL of the internal standard solution, add the mobile phase to make 100 mL, and use this solution as the standard solution. Then, proceed as directed in the Assay under Amlexanox.

$$\begin{aligned} &\text{Amount (mg) of amlexanox (C}_{16}\text{H}_{14}\text{N}_2\text{O}_4) \\ &= M_S \times Q_T/Q_S \times 1/2 \end{aligned}$$

M_S: Amount (mg) of Amlexanox RS taken

Internal standard solution—A solution of 3-nitroaniline in the mobile phase (1 in 500).

Containers and storage Containers—Tight containers.

Amlodipine Besilate

アムロジピンベシル酸塩

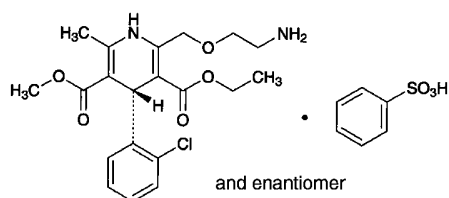

$C_{20}H_{25}ClN_2O_5 \cdot C_6H_6O_3S$: 567.05

3-Ethyl 5-methyl (4*RS*)-2-[(2-aminoethoxy)methyl]-4-(2-chlorophenyl)-6-methyl-1,4-dihydropyridine-3,5-dicarboxylate monobenzenesulfonate

[111470-99-6]

Amlodipine Besilate contains not less than 98.0% and not more than 102.0% of amlodipine besilate ($C_{20}H_{25}ClN_2O_5 \cdot C_6H_6O_3S$), calculated on the anhydrous basis.

Description Amlodipine Besilate occurs as a white to yellowish white crystalline powder.

It is freely soluble in methanol, sparingly soluble in ethanol (99.5), and slightly soluble in water.

A solution of Amlodipine Besilate in methanol (1 in 100) shows no optical rotation.

Melting point: about 198°C (with decomposition).

Identification (1) Determine the absorption spectrum of a solution of Amlodipine Besilate in 0.01 mol/L hydrochloric acid-methanol TS (1 in 40,000) as directed under Ultraviolet-visible Spectrophotometry <2.24>, and compare the spectrum with the Reference Spectrum or the spectrum of a solution of Amlodipine Besilate RS prepared in the same manner as the sample solution: both spectra exhibit similar intensities of absorption at the same wavelengths.

(2) Determine the infrared absorption spectrum of Amlodipine Besilate as directed in the potassium bromide disk method under Infrared Spectrophotometry <2.25>, and compare the spectrum with the Reference Spectrum or the spectrum of Amlodipine Besilate RS: both spectra exhibit similar intensities of absorption at the same wave numbers.

(3) To 30 mg of Amlodipine Besilate add 0.1 g of sodium nitrate and 0.1 g of anhydrous sodium carbonate, mix, and gradually ignite. After cooling, dissolve the residue in 2 mL of dilute hydrochloric acid and 10 mL of water, filter if necessary, and add barium chloride TS: a white precipitate is formed.

Purity (1) Heavy metals <1.07>—Proceed with 1.0 g of Amlodipine Besilate according to Method 4, and perform the test. Prepare the control solution with 2.5 mL of Standard Lead Solution (not more than 25 ppm).

(2) Related substances—Dissolve 0.10 g of Amlodipine Besilate in 50 mL of a mixture of water and acetonitrile (1:1), and use this solution as the sample solution. Pipet 1 mL of the sample solution, and add the mixture of water and acetonitrile (1:1) to make exactly 100 mL. Pipet 3 mL of this solution, add the mixture of water and acetonitrile (1:1) to make exactly 10 mL, and use this solution as the standard solution. Perform the test with exactly 10 μL each of the sample solution and standard solution as directed under Liquid Chromatography <2.01> according to the following conditions, and determine each peak area by the automatic integration method: the area of the peak having the relative

retention time of 0.90 to amlodipine, obtained from the sample solution is not larger than the peak area of amlodipine from the standard solution, and the area of the peak other than amlodipine, benzenesulfonic acid having the relative retention time of about 0.15, and the peak mentioned above from the sample solution is not larger than 1/3 times the peak area of amlodipine from the standard solution. Furthermore, the total area of the peaks other than amlodipine and benzenesulfonic acid from the sample solution is not larger than 2.7 times the peak area of amlodipine from the standard solution.

Operating conditions—

Detector: An ultraviolet absorption photometer (wavelength: 237 nm).

Column: A stainless steel column 4.6 mm in inside diameter and 15 cm in length, packed with octadecylsilanized silica gel for liquid chromatography (3 μm in particle diameter).

Column temperature: A constant temperature of about 35°C.

Mobile phase A: A mixture of water and trifluoroacetic acid (5000:1).

Mobile phase B: A mixture of acetonitrile and trifluoroacetic acid (5000:1).

Flowing of mobile phase: Control the gradient by mixing the mobile phases A and B as directed in the following table.

Time after injection of sample (min)	Mobile phase A (vol%)	Mobile phase B (vol%)
0 – 30	80 → 20	20 → 80
30 – 45	20	80

Flow rate: 1.0 mL per minute.

Time span of measurement: About 3 times as long as the retention time of amlodipine, beginning after the solvent peak.

System suitability—

Test for required detectability: Pipet 1 mL of the standard solution, and add a mixture of water and acetonitrile (1:1) to make exactly 10 mL. Confirm that the peak area of amlodipine obtained with 10 μL of this solution is equivalent to 7 to 13% of that with 10 μL of the standard solution.

System performance: When the procedure is run with 10 μL of the standard solution under the above operating conditions, the number of theoretical plates and the symmetry factor of the peak of amlodipine are not less than 70,000 and not more than 1.5, respectively.

System repeatability: When the test is repeated 6 times with 10 μL of the standard solution under the above operating conditions, the relative standard deviation of the peak area of amlodipine is not more than 2.0%.

Water <2.48> Not more than 0.5% (1 g, volumetric titration, direct titration).

Residue on ignition <2.44> Not more than 0.2% (1 g).

Assay Weigh accurately about 35 mg each of Amlodipine Besilate and Amlodipine Besilate RS (separately determine the water <2.48> using the same manner as Amlodipine Besilate), dissolve them separately in the mobile phase to make exactly 250 mL. Pipet 5 mL each of these solutions, add exactly 5 mL each of the internal standard solution, add the mobile phase to make 25 mL, and use these solutions as the sample solution and standard solution. Perform the test with 20 μL of the sample solution and standard solution as directed under Liquid Chromatography <2.01> according to the following conditions, and calculate the ratios, Q_T and

Q_s , of the peak area of amlodipine to that of the internal standard.

$$\begin{aligned} & \text{Amount (mg) of amlodipine besilate} \\ & (\text{C}_{20}\text{H}_{25}\text{ClN}_2\text{O}_5 \cdot \text{C}_6\text{H}_6\text{O}_3\text{S}) \\ & = M_s \times Q_T / Q_s \end{aligned}$$

M_s : Amount (mg) of Amlodipine Besilate RS taken, calculated on the anhydrous basis

Internal standard solution—A solution of isobutyl parahydroxybenzoate in the mobile phase (3 in 20,000).

Operating conditions—

Detector: An ultraviolet absorption photometer (wavelength: 237 nm).

Column: A stainless steel column 4.6 mm in inside diameter and 15 cm in length, packed with octadecylsilanized silica gel for liquid chromatography (5 μm in particle diameter).

Column temperature: A constant temperature of about 25°C.

Mobile phase: A mixture of methanol and a solution of potassium dihydrogen phosphate (41 in 10,000) (13:7).

Flow rate: Adjust so that the retention time of amlodipine is about 8 minutes.

System suitability—

System performance: When the procedure is run with 20 μL of the standard solution under the above operating conditions, amlodipine and the internal standard are eluted in this order with the resolution between these peaks being not less than 3.

System repeatability: When the test is repeated 6 times with 20 μL of the standard solution under the above operating conditions, the relative standard deviation of the ratio of the peak area of amlodipine to that of the internal standard is not more than 1.0%.

Containers and storage Containers—Well-closed containers.

Storage—Light-resistant.

Amlodipine Besilate Orally Disintegrating Tablets

アムロジピンベシル酸塩口腔内崩壊錠

Amlodipine Besilate Orally Disintegrating Tablets contain not less than 95.0% and not more than 105.0% of the labeled amount of amlodipine besilate ($\text{C}_{20}\text{H}_{25}\text{ClN}_2\text{O}_5 \cdot \text{C}_6\text{H}_6\text{O}_3\text{S}$: 567.05).

Method of preparation Prepare as directed under Tablets, with Amlodipine Besilate.

Identification To an amount of powdered Amlodipine Besilate Orally Disintegrating Tablets, equivalent to 7 mg of Amlodipine Besilate, add 200 mL of 0.01 mol/L hydrochloric acid-methanol TS, treat with ultrasonic waves, and filter. Determine the absorption spectrum of the filtrate as directed under Ultraviolet-visible Spectrophotometry <2.24>: it exhibits a maximum between 358 nm and 362 nm.

Purity Related substances—Use the sample solution obtained in the Assay as the sample solution. Pipet 1 mL of the sample solution, add a mixture of methanol and the mobile phase A (3:2) to make exactly 200 mL, and use this solution as the standard solution. Perform the test with exactly 30 μL each of the sample solution and standard solution as directed under Liquid Chromatography <2.01> according to the fol-

lowing conditions, and determine each peak area by the automatic integration method: the area of the peak having the relative retention time of about 0.45 to amlodipine obtained from the sample solution is not larger than the peak area of amlodipine from the standard solution, the area of the peak having the relative retention time of about 4.5 to amlodipine from the sample solution is not larger than 1.8 times the peak area of amlodipine from the standard solution, and the area of the peak having the relative retention time of about 0.16 to amlodipine and the peaks other than mentioned above from the sample solution is not larger than 2/5 times the peak area of amlodipine from the standard solution. Furthermore, the total area of the peaks other than amlodipine and the peak having the relative retention time of about 0.16 to amlodipine from the sample solution is not larger than 2.8 times the peak area of amlodipine from the standard solution. For the areas of the peaks, having the relative retention time of about 0.45 and about 4.5 to amlodipine, multiply their correction factors, 2.0 and 1.9, respectively.

Operating conditions—

Detector: An ultraviolet absorption photometer (wavelength: 237 nm).

Column: A stainless steel column 4.6 mm in inside diameter and 15 cm in length, packed with octadecylsilanized silica gel for liquid chromatography (5 μm in particle diameter).

Column temperature: A constant temperature of about 25°C.

Mobile phase A: Dissolve 4.1 g of potassium dihydrogen phosphate in 1000 mL of water, adjust to pH 6.0 with a solution of 5.4 g of disodium hydrogen phosphate dodecahydrate in 500 mL of water. To 500 mL of this solution add 500 mL of methanol.

Mobile phase B: Dissolve 4.1 g of potassium dihydrogen phosphate in 1000 mL of water, adjust to pH 6.0 with a solution of 5.4 g of disodium hydrogen phosphate dodecahydrate in 500 mL of water. To 50 mL of this solution add 950 mL of methanol.

Flowing of mobile phase: Control the gradient by mixing the mobile phases A and B as directed in the following table.

Time after injection of sample (min)	Mobile phase A (vol%)	Mobile phase B (vol%)
0 - 10	80	20
10 - 35	80 → 0	20 → 100
35 - 50	0	100

Flow rate: Adjust so that the retention time of amlodipine is about 10 minutes.

Time span of measurement: About 5 times as long as the retention time of amlodipine.

System suitability—

Test for required detectability: Pipet 10 mL of the standard solution, and add a mixture of methanol and the mobile phase A (3:2) to make exactly 50 mL. Confirm that the peak area of amlodipine obtained with 30 μL of this solution is equivalent to 14 to 26% of that with 30 μL of the standard solution.

System performance: When the procedure is run with 30 μL of the standard solution under the above operating conditions, the number of theoretical plates and the symmetry factor of the peak of amlodipine are not less than 3000 and not more than 1.5, respectively.

System repeatability: When the test is repeated 6 times with 30 μL of the standard solution under the above operating conditions, the relative standard deviation of the peak area of amlodipine is not more than 2.0%.

Uniformity of dosage units <6.02> Perform the test according to the following method: it meets the requirement of the Content uniformity test.

To 1 tablet of Amlodipine Besilate Orally Disintegrating Tablets add 4V/5 mL of a mixture of the mobile phase and methanol (1:1), disperse the particles by sonicating, add a mixture of the mobile phase and methanol (1:1) to make exactly V mL so that each mL of the solution contains about 0.14 mg of amlodipine besilate (C₂₀H₂₅ClN₂O₅·C₆H₆O₃S). Centrifuge this solution, and use the supernatant liquid as the sample solution. Then, proceed as directed in the Assay.

$$\begin{aligned} & \text{Amount (mg) of amlodipine besilate} \\ & (\text{C}_{20}\text{H}_{25}\text{ClN}_2\text{O}_5 \cdot \text{C}_6\text{H}_6\text{O}_3\text{S}) \\ & = M_S \times A_T/A_S \times V \times 1/250 \end{aligned}$$

M_S: Amount (mg) of Amlodipine Besilate RS taken, calculated on the anhydrous basis

Disintegration Being specified separately when the drug is granted approval based on the Law.

Dissolution Being specified separately when the drug is granted approval based on the Law.

Assay Weigh accurately the mass of not less than 20 Amlodipine Besilate Orally Disintegrating Tablets, and powder them. Weigh accurately a portion of this powder, equivalent to about 7 mg of amlodipine besilate (C₂₀H₂₅ClN₂O₅·C₆H₆O₃S), add 40 mL of a mixture of the mobile phase and methanol (1:1), disperse the particles with the aid of ultrasonic waves, and add a mixture of the mobile phase and methanol (1:1) to make exactly 50 mL. Centrifuge this solution, and use the supernatant liquid as the sample solution. Separately, weigh accurately about 35 mg of Amlodipine Besilate RS (separately, determine the water <2.48> in the same manner as Amlodipine Besilate), add 150 mL of a mixture of the mobile phase and methanol (1:1), dissolve with the aid of ultrasonic waves, then add a mixture of the mobile phase and methanol (1:1) to make exactly 250 mL, and use this solution as the standard solution. Perform the test with exactly 30 μL each of the sample solution and standard solution as directed under Liquid Chromatography <2.01>, and determine the peak areas, A_T and A_S, of amlodipine in each solution.

$$\begin{aligned} & \text{Amount (mg) of amlodipine besilate} \\ & (\text{C}_{20}\text{H}_{25}\text{ClN}_2\text{O}_5 \cdot \text{C}_6\text{H}_6\text{O}_3\text{S}) \\ & = M_S \times A_T/A_S \times 1/5 \end{aligned}$$

M_S: Amount (mg) of Amlodipine Besilate RS taken, calculated on the anhydrous basis

Operating conditions—

Detector: An ultraviolet absorption photometer (wavelength: 237 nm).

Column: A stainless steel column 4.6 mm in inside diameter and 15 cm in length, packed with octadecylsilanized silica gel for liquid chromatography (5 μm in particle diameter).

Column temperature: A constant temperature of about 25°C.

Mobile phase: Dissolve 4.1 g of potassium dihydrogen phosphate in 1000 mL of water, adjust to pH 6.0 with a solution of 5.4 g of disodium hydrogen phosphate dodecahydrate in 500 mL of water. To 400 mL of this solution add 600 mL of methanol.

Flow rate: Adjust so that the retention time of amlodipine is about 10 minutes.

System suitability—

System performance: When the procedure is run with 30 μL of the standard solution under the above operating con-

ditions, the number of theoretical plates and the symmetry factor of the peak of amlodipine are not less than 3000 and not more than 2.0, respectively.

System repeatability: When the test is repeated 6 times with 30 μL of the standard solution under the above operating conditions, the relative standard deviation of the peak area of amlodipine is not more than 1.0%.

Containers and storage Containers—Tight containers.

Amlodipine Besilate Tablets

アムロジピンベシル酸塩錠

Amlodipine Besilate Tablets contain not less than 95.0% and not more than 105.0% of the labeled amount of amlodipine besilate (C₂₀H₂₅ClN₂O₅·C₆H₆O₃S; 567.05).

Method of preparation Prepare as directed under Tablets, with Amlodipine Besilate.

Identification To a quantity of powdered Amlodipine Besilate Tablets, equivalent to 2.5 mg of Amlodipine Besilate, add 100 mL of 0.01 mol/L hydrochloric acid-methanol TS, shake vigorously, and filter. Determine the absorption spectrum of the filtrate as directed under Ultraviolet-visible Spectrophotometry <2.24>: it exhibits maxima between 235 nm and 239 nm, and between 358 nm and 362 nm.

Uniformity of dosage units <6.02> Perform the test according to the following method: it meets the requirement of the Content uniformity test.

To 1 tablet of Amlodipine Besilate Tablets add 10 mL of water to disintegrate, disperse by sonicating with occasional shaking, add the mobile phase to make exactly V mL so that each mL contains about 69 μg of amlodipine besilate (C₂₀H₂₅ClN₂O₅·C₆H₆O₃S), and shake for 60 minutes. Centrifuge this solution, pipet 10 mL of the supernatant liquid, add exactly 5 mL of the internal standard solution, add the mobile phase to make 25 mL, and use this solution as the sample solution. Proceed as directed in the Assay.

$$\begin{aligned} & \text{Amount (mg) of amlodipine besilate} \\ & (\text{C}_{20}\text{H}_{25}\text{ClN}_2\text{O}_5 \cdot \text{C}_6\text{H}_6\text{O}_3\text{S}) \\ & = M_S \times Q_T/Q_S \times V/500 \end{aligned}$$

M_S: Amount (mg) of Amlodipine Besilate RS taken, calculated on the anhydrous basis

Internal standard solution—A solution of isobutyl parahydroxybenzoate in the mobile phase (3 in 20,000).

Dissolution Being specified separately when the drug is granted approval based on the Law.

Assay To 20 Amlodipine Besilate Tablets add 100 mL of water to disintegrate, disperse with the aid of ultrasonic waves with occasional shaking, add the mobile phase to make exactly 1000 mL, and shake for 60 minutes. Centrifuge this solution, pipet a volume of the supernatant liquid, equivalent to about 0.7 mg of amlodipine besilate (C₂₀H₂₅ClN₂O₅·C₆H₆O₃S), add exactly 5 mL of the internal standard solution, add the mobile phase to make 25 mL, and use this solution as the sample solution. Separately, weigh accurately about 35 mg of Amlodipine Besilate RS (separately, determine the water <2.48> in the same manner as Amlodipine Besilate), and dissolve in the mobile phase to make exactly 250 mL. Pipet 5 mL of this solution, add exactly 5 mL of the internal standard solution, add the mobile

phase to make 25 mL, and use this solution as the standard solution. Perform the test with 20 μ L each of the sample solution and standard solution as directed under Liquid Chromatography <2.01> according to the following conditions, and calculate the ratios, Q_T and Q_S , of the peak area of amlodipine to that of the internal standard.

$$\begin{aligned} & \text{Amount (mg) of amlodipine besilate} \\ & (\text{C}_{20}\text{H}_{25}\text{ClN}_2\text{O}_5 \cdot \text{C}_6\text{H}_6\text{O}_3\text{S}) \\ & = M_S \times Q_T / Q_S \times 1/50 \end{aligned}$$

M_S : Amount (mg) of Amlodipine Besilate RS taken, calculated on the anhydrous basis

Internal standard solution—A solution of isobutyl parahydroxybenzoate in the mobile phase (3 in 20,000).

Operating conditions—

Detector: An ultraviolet absorption photometer (wavelength: 237 nm).

Column: A stainless steel column 4.6 mm in inside diameter and 15 cm in length, packed with octadecylsilanized silica gel for liquid chromatography (5 μ m in particle diameter).

Column temperature: A constant temperature of about 25°C.

Mobile phase: A mixture of methanol and potassium dihydrogen phosphate (41 in 10,000) (13:7).

Flow rate: Adjust so that the retention time of amlodipine is about 8 minutes.

System suitability—

System performance: When the procedure is run with 20 μ L of the standard solution under the above operating conditions, amlodipine and the internal standard are eluted in this order with the resolution between these peaks being not less than 5.

System repeatability: When the test is repeated 6 times with 20 μ L of the standard solution under the above operating conditions, the relative standard deviation of the ratios of the peak area of amlodipine to that of the internal standard is not more than 1.0%.

Containers and storage Containers—Well-closed containers.

Ammonia Water

アンモニア水

Ammonia Water contains not less than 9.5 w/v% and not more than 10.5 w/v% of ammonia (NH_3 ; 17.03).

Description Ammonia Water occurs as a clear, colorless liquid, having a very pungent, characteristic odor.

It is alkaline.

Specific gravity d_{20}^{20} : 0.95 – 0.96

Identification (1) Hold a glass rod moistened with hydrochloric acid near the surface of Ammonia Water: dense white fumes are produced.

(2) Hold moistened red litmus paper near the surface of Ammonia Water: it turns blue.

Purity (1) Residue on evaporation—Evaporate 10.0 mL of Ammonia Water to dryness, and dry the residue at 105°C for 1 hour: the mass of the residue is not more than 2.0 mg.

(2) Heavy metals <1.07>—Evaporate 5.0 mL of Ammonia Water to dryness on a water bath, add 1 mL of dilute hydrochloric acid to the residue, and evaporate to dryness. Dissolve the residue in 2 mL of dilute acetic acid, add water

to make 50 mL, and perform the test using this solution as the test solution. Prepare the control solution with 2.5 mL of Standard Lead Solution, 2 mL of dilute acetic acid and water to make 50 mL (not more than 5 ppm).

(3) Potassium permanganate-reducing substances—To 10.0 mL of Ammonia Water add 40 mL of dilute sulfuric acid while cooling, and add 0.10 mL of 0.02 mol/L potassium permanganate VS: the red color of the potassium permanganate does not disappear within 10 minutes.

Assay Pipet 5 mL of Ammonia Water, add 25 mL of water, and titrate <2.50> with 0.5 mol/L sulfuric acid VS (indicator: 2 drops of methyl red TS).

$$\begin{aligned} & \text{Each mL of 0.5 mol/L sulfuric acid VS} \\ & = 17.03 \text{ mg of NH}_3 \end{aligned}$$

Containers and storage Containers—Tight containers.

Storage—Not exceeding 30°C.

Amobarbital

アモバルビタール

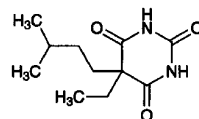

$\text{C}_{11}\text{H}_{18}\text{N}_2\text{O}_3$: 226.27

5-Ethyl-5-(3-methylbutyl)pyrimidine-2,4,6(1H,3H,5H)-trione
[57-43-2]

Amobarbital, when dried, contains not less than 99.0% of amobarbital ($\text{C}_{11}\text{H}_{18}\text{N}_2\text{O}_3$).

Description Amobarbital occurs as white, crystals or crystalline powder. It is odorless, and has a slightly bitter taste.

It is freely soluble in ethanol (95), in acetone and in diethyl ether, sparingly soluble in chloroform, and practically insoluble in water.

It dissolves in sodium hydroxide TS and in sodium carbonate TS.

The pH of a saturated solution of Amobarbital is between 5.0 and 5.6.

Identification (1) Boil 0.2 g of Amobarbital with 10 mL of sodium hydroxide TS: the gas evolved changes moistened red litmus paper to blue.

(2) Dissolve 0.05 g of Amobarbital in 2 to 3 drops of ammonia-ammonium chloride buffer solution (pH 10.7) and 5 mL of diluted pyridine (1 in 10). Add 5 mL of chloroform and 0.3 mL of copper (II) sulfate TS to the solution: a red-purple precipitate is produced in the aqueous layer. Shake the mixture: a red-purple color is produced in the chloroform layer.

(3) To 0.4 g of Amobarbital add 0.1 g of anhydrous sodium carbonate and 4 mL of water, shake, and add a solution of 0.3 g of 4-nitrobenzyl chloride in 7 mL of ethanol (95). Heat the mixture on a water bath for 30 minutes under a reflux condenser, and allow to stand for 1 hour. Filter the crystals produced, wash with 7 mL of sodium hydroxide TS and a small portion of water, recrystallize from ethanol, and dry at 105°C for 30 minutes: the crystals so obtained melt <2.60> between 168°C and 173°C or between 150°C and 154°C.

Melting point <2.60> 157 – 160°C

Purity (1) Clarity and color of solution—Dissolve 0.5 g of Amobarbital in 5 mL of sodium hydroxide TS: the solution is clear and colorless.

(2) Chloride <1.03>—Dissolve 0.30 g of Amobarbital in 20 mL of acetone, and add 6 mL of dilute nitric acid and water to make 50 mL. Perform the test using this solution as the test solution. Prepare the control solution as follows: take 0.30 mL of 0.01 mol/L hydrochloric acid VS, 20 mL of acetone and 6 mL of dilute nitric acid, and add water to make 50 mL (not more than 0.035%).

(3) Sulfate <1.14>—Dissolve 0.40 g of Amobarbital in 20 mL of acetone, and add 1 mL of dilute hydrochloric acid and water to make 50 mL. Perform the test using this solution as the test solution. Prepare the control solution as follows: take 0.40 mL of 0.005 mol/L sulfuric acid VS, 20 mL of acetone, and 1 mL of dilute hydrochloric acid, and add water to make 50 mL (not more than 0.048%).

(4) Heavy metals <1.07>—Proceed with 1.0 g of Amobarbital according to Method 2, and perform the test. Prepare the control solution with 2.0 mL of Standard Lead Solution (not more than 20 ppm).

(5) Readily carbonizable substances <1.15>—Perform the test with 0.5 g of Amobarbital. The solution is not more colored than Matching Fluid A.

Loss on drying <2.41> Not more than 1.0% (1 g, 105°C, 4 hours).

Residue on ignition <2.44> Not more than 0.1% (1 g).

Assay Weigh accurately about 0.5 g of Amobarbital, previously dried, and dissolve in 5 mL of ethanol (95) and 50 mL of chloroform. Titrate <2.50> with 0.1 mol/L potassium hydroxide-ethanol VS until the color of the solution changes from yellow through light blue to purple (indicator: 1 mL of alizarin yellow GG-thymolphthalein TS). Perform a blank determination in the same manner, and make any necessary correction.

Each mL of 0.1 mol/L potassium hydroxide-ethanol VS = 22.63 mg of $C_{18}H_{24}N_2O_5S$

Containers and storage Containers—Well-closed containers.

Amosulalol Hydrochloride

アモスラロール塩酸塩

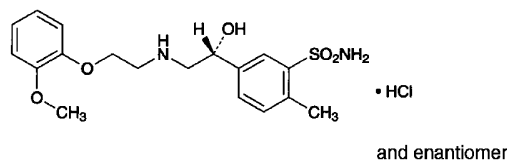

$C_{18}H_{24}N_2O_5S \cdot HCl$: 416.92
5-((1*R*S)-1-Hydroxy-2-[[2-(2-methoxyphenoxy)ethyl]amino]ethyl)-2-methylbenzenesulfonamide monohydrochloride
[70958-86-0]

Amosulalol Hydrochloride contains not less than 98.5% and not more than 101.0% of amosulalol hydrochloride ($C_{18}H_{24}N_2O_5S \cdot HCl$), calculated on the anhydrous basis.

Description Amosulalol Hydrochloride occurs as white crystals or a white crystalline powder. It has a bitter taste.

It is very soluble in formic acid, freely soluble in metha-

anol, and sparingly soluble in water and in ethanol (99.5).

It is hygroscopic.

A solution of Amosulalol Hydrochloride in methanol (1 in 100) shows no optical rotation.

Identification (1) Determine the absorption spectrum of a solution of Amosulalol Hydrochloride (1 in 20,000) as directed under Ultraviolet-visible Spectrophotometry <2.24>, and compare the spectrum with the Reference Spectrum: both spectra exhibit similar intensities of absorption at the same wavelengths.

(2) Determine the infrared absorption spectrum of Amosulalol Hydrochloride as directed in the potassium chloride disk method under Infrared Spectrophotometry <2.25>, and compare the spectrum with the Reference Spectrum: both spectra exhibit similar intensities of absorption at the same wave numbers.

(3) A solution of Amosulalol Hydrochloride (1 in 100) responds to Qualitative Tests <1.09> for chloride.

Melting point <2.60> 158 – 162°C

Purity (1) Heavy metals <1.07>—Place 1.0 g of Amosulalol Hydrochloride in a porcelain crucible, add 1.5 mL of sulfuric acid, cover loosely, and heat gently to carbonize. After cooling, add 2 mL of nitric acid, heat carefully until white fumes no longer are evolved, and then heat intensely to 500 – 600°C to incinerate. After cooling, add 2 mL of hydrochloric acid, proceed according to Method 2, and perform the test. The control solution, processed in the same manner as the test solution using the same amounts of reagents, is prepared by combining 2.0 mL of Standard Lead Solution and water to make 50 mL (not more than 20 ppm).

(2) Related substances—Dissolve 0.10 g of Amosulalol Hydrochloride in 20 mL of the mobile phase, and use this solution as the sample solution. Pipet 1 mL of the sample solution, add the mobile phase to make exactly 200 mL, and use this solution as the standard solution. Perform the test with exactly 10 μ L each of the sample solution and standard solution as directed under Liquid Chromatography <2.01> according to the following conditions, and determine each peak area of both solutions by the automatic integration method: the total area of the peaks other than amosulalol obtained from the sample solution is not larger than 2/5 times the peak area of amosulalol from the standard solution.

Operating conditions—

Detector: An ultraviolet absorption photometer (wavelength: 272 nm).

Column: A stainless steel column 4.6 mm in inside diameter and 15 cm in length, packed with octadecylsilanized silica gel for liquid chromatography (5 μ m in particle diameter).

Column temperature: A constant temperature of about 30°C.

Mobile phase: Dissolve 1.36 g of potassium dihydrogen phosphate in water to make 1000 mL, and adjust to pH 5.7 by adding a solution prepared by dissolving 3.58 g of disodium hydrogen phosphate dodecahydrate in water to make 1000 mL. To 670 mL of this solution add 330 mL of acetonitrile.

Flow rate: Adjust so that the retention time of amosulalol is about 7 minutes.

Time span of measurement: About 2 times as long as the retention time of amosulalol, beginning after the solvent peak.

System suitability—

Test for required detectability: Pipet 1 mL of the standard solution, and add the mobile phase to make exactly 10 mL.

Confirm that the peak area of amosulalol obtained with 10 μL of this solution is equivalent to 7 to 13% of that with 10 μL of the standard solution.

System performance: When the procedure is run with 10 μL of the standard solution under the above operating conditions, the number of theoretical plates and the symmetry factor of the peak of amosulalol are not less than 4000 and not more than 1.7, respectively.

System repeatability: When the test is repeated 6 times with 10 μL of the standard solution under the above operating conditions, the relative standard deviation of the peak area of amosulalol is not more than 1.0%.

Water <2.48> Not more than 4.0% (1 g, volumetric titration, direct titration).

Residue on ignition <2.44> Not more than 0.1% (1 g).

Assay Weigh accurately about 0.6 g of Amosulalol Hydrochloride, dissolve in 3 mL of formic acid, add 80 mL of a mixture of acetic acid (100) and acetic anhydride (3:2), and titrate <2.50> within 5 minutes with 0.1 mol/L perchloric acid VS (potentiometric titration). Perform a blank determination in the same manner, and make any necessary correction.

Each mL of 0.1 mol/L perchloric acid VS
= 41.69 mg of $\text{C}_{18}\text{H}_{24}\text{N}_2\text{O}_5\text{S}\cdot\text{HCl}$

Containers and storage Containers—Tight containers.

Amosulalol Hydrochloride Tablets

アモスラロール塩酸塩錠

Amosulalol Hydrochloride Tablets contain not less than 95.0% and not more than 105.0% of the labeled amount of amosulalol hydrochloride ($\text{C}_{18}\text{H}_{24}\text{N}_2\text{O}_5\text{S}\cdot\text{HCl}$: 416.92).

Method of preparation Prepare as directed under Tablets, with Amosulalol Hydrochloride.

Identification To a quantity of powdered Amosulalol Hydrochloride Tablets, equivalent to 50 mg of Amosulalol Hydrochloride, add 25 mL of 0.1 mol/L hydrochloric acid TS, shake well, and then centrifuge. To 2.5 mL of the supernatant liquid add water to make 100 mL. Determine the absorption spectrum of this solution as directed under Ultraviolet-visible Spectrophotometry <2.24>: it exhibits a maximum between 270 nm and 274 nm, and a shoulder between 275 nm and 281 nm.

Uniformity of dosage units <6.02> Perform the test according to the following method: it meets the requirement of the Content uniformity test.

Take 1 tablet of Amosulalol Hydrochloride Tablets, disintegrate by adding 2 mL of 0.1 mol/L hydrochloric acid TS, add 15 mL of methanol, and shake well. Add methanol to make exactly V mL so that each mL contains about 0.4 mg of amosulalol hydrochloride ($\text{C}_{18}\text{H}_{24}\text{N}_2\text{O}_5\text{S}\cdot\text{HCl}$), and centrifuge. Pipet 5 mL of the supernatant liquid, add exactly 2 mL of the internal standard solution and the mobile phase to make 20 mL, and use this solution as the sample solution. Separately, weigh accurately about 20 mg of amosulalol hydrochloride for assay (separately determine the water <2.48> in the same manner as Amosulalol Hydrochloride), and dissolve in methanol to make exactly 50 mL. Pipet 5 mL of this solution, add exactly 2 mL of the internal standard

solution, add the mobile phase to make 20 mL, and use this solution as the standard solution. Then, proceed as directed in the Assay.

$$\begin{aligned} &\text{Amount (mg) of amosulalol hydrochloride} \\ &(\text{C}_{18}\text{H}_{24}\text{N}_2\text{O}_5\text{S}\cdot\text{HCl}) \\ &= M_S \times Q_T/Q_S \times V/50 \end{aligned}$$

M_S : Amount (mg) of amosulalol hydrochloride for assay taken, calculated on the anhydrous basis

Internal standard solution—A solution of ethyl parahydroxybenzoate in methanol (1 in 6250).

Dissolution <6.10> When the test is performed at 50 revolutions per minute according to the Paddle method, using 900 mL of water as the dissolution medium, the dissolution rate in 30 minutes of Amosulalol Hydrochloride Tablets is not less than 75%.

Start the test with 1 tablet of Amosulalol Hydrochloride Tablets, withdraw not less than 20 mL of the medium at the specified minute after starting the test, and filter through a membrane filter with a pore size not exceeding 0.5 μm . Discard not less than 10 mL of the first filtrate, pipet V' mL of the subsequent filtrate, add water to make exactly V' mL so that each mL contains about 5.5 μg of amosulalol hydrochloride ($\text{C}_{18}\text{H}_{24}\text{N}_2\text{O}_5\text{S}\cdot\text{HCl}$), and use this solution as the sample solution. Separately, weigh accurately about 22 mg of amosulalol hydrochloride for assay (separately determine the water <2.48> in the same manner as Amosulalol Hydrochloride), and dissolve in water to make exactly 200 mL. Pipet 5 mL of this solution, add water to make exactly 100 mL, and use this solution as the standard solution. Perform the test with exactly 50 μL each of the sample solution and standard solution as directed under Liquid Chromatography <2.01> according to the following conditions, and determine the amosulalol peak areas, A_T and A_S , in each solution.

$$\begin{aligned} &\text{Dissolution rate (\%)} \text{ with respect to the labeled amount} \\ &\text{of amosulalol hydrochloride } (\text{C}_{18}\text{H}_{24}\text{N}_2\text{O}_5\text{S}\cdot\text{HCl}) \\ &= M_S \times A_T/A_S \times V'/V \times 1/C \times 45/2 \end{aligned}$$

M_S : Amount (mg) of amosulalol hydrochloride for assay taken, calculated on the anhydrous basis

C : Labeled amount (mg) of amosulalol hydrochloride ($\text{C}_{18}\text{H}_{24}\text{N}_2\text{O}_5\text{S}\cdot\text{HCl}$) in 1 tablet

Operating conditions—

Detector: An ultraviolet absorption photometer (wavelength: 272 nm).

Column: A stainless steel column 4.6 mm in inside diameter and 15 cm in length, packed with octadecylsilanized silica gel for liquid chromatography (5 μm in particle diameter).

Column temperature: A constant temperature of about 30°C.

Mobile phase: Dissolve 1.36 g of potassium dihydrogen phosphate in water to make 1000 mL, and adjust to pH 5.7 by adding a solution prepared by dissolving 3.58 g of disodium hydrogen phosphate dodecahydrate in water to make 1000 mL. To 670 mL of this solution add 330 mL of acetonitrile.

Flow rate: Adjust so that the retention time of amosulalol is about 5 minutes.

System suitability—

System performance: When the procedure is run with 50 μL of the standard solution under the above operating conditions, the number of theoretical plates and the symmetry factor of the peak of amosulalol are not less than 4000 and not more than 1.7, respectively.

System repeatability: When the test is repeated 6 times

with 50 μ L of the standard solution under the above operating conditions, the relative standard deviation of the peak area of amosulalol is not more than 1.0%.

Assay Take 10 Amosulalol Hydrochloride Tablets, add 20 mL of 0.1 mol/L hydrochloric acid TS, and shake well to disintegrate. Add 120 mL of methanol, again shake well, add methanol to make exactly 200 mL, and then centrifuge. Pipet a volume of supernatant liquid corresponding to about 5 mg of amosulalol hydrochloride ($C_{18}H_{24}N_2O_5S \cdot HCl$), add exactly 5 mL of the internal standard solution, add the mobile phase to make 50 mL, and use this solution as the sample solution. Separately, weigh accurately about 25 mg of amosulalol hydrochloride for assay (separately determine the water <2.48> in the same manner as Amosulalol Hydrochloride), and dissolve in methanol to make exactly 25 mL. Pipet 5 mL of this solution, add exactly 5 mL of the internal standard solution, add the mobile phase to make 50 mL, and use this solution as the standard solution. Perform the test with 10 μ L each of the sample solution and standard solution as directed under Liquid Chromatography <2.01> according to the following conditions, and calculate the ratios, Q_T and Q_S , of the peak area of amosulalol to that of the internal standard.

$$\begin{aligned} & \text{Amount (mg) of amosulalol hydrochloride} \\ & (C_{18}H_{24}N_2O_5S \cdot HCl) \\ & = M_S \times Q_T / Q_S \times 1/5 \end{aligned}$$

M_S : Amount (mg) of amosulalol hydrochloride for assay taken, calculated on the anhydrous basis

Internal standard solution—A solution of ethyl parahydroxybenzoate in methanol (1 in 6250).

Operating conditions—

Detector: An ultraviolet absorption photometer (wavelength: 272 nm).

Column: A stainless steel column 4.6 mm in inside diameter and 15 cm in length, packed with octadecylsilanized silica gel for liquid chromatography (5 μ m in particle diameter).

Column temperature: A constant temperature of about 25°C.

Mobile phase: A mixture of diluted acetic acid (100) (1 in 25), acetonitrile and a solution of ammonium acetate (1 in 250) (5:3:2).

Flow rate: Adjust so that the retention time of amosulalol is about 4 minutes.

System suitability—

System performance: When the procedure is run with 10 μ L of the standard solution under the above operating conditions, amosulalol and the internal standard are eluted in this order with the resolution between these peaks being not less than 7.

System repeatability: When the test is repeated 6 times with 10 μ L of the standard solution under the above operating conditions, the relative standard deviation of the ratio of the peak area of amosulalol to that of the internal standard is not more than 1.0%.

Containers and storage Containers—Tight containers.

Amoxapine

アモキサピン

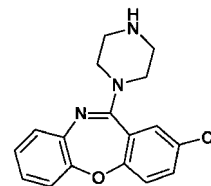

$C_{17}H_{16}ClN_3O$: 313.78

2-Chloro-11-(piperazin-1-yl)dibenzo[*b,f*][1,4]oxazepine
[14028-44-5]

Amoxapine, when dried, contains not less than 98.5% of amoxapine ($C_{17}H_{16}ClN_3O$).

Description Amoxapine occurs as white to light yellow-white, crystals or crystalline powder.

It is freely soluble in acetic acid (100), slightly soluble in ethanol (95) and in diethyl ether, and practically insoluble in water.

Identification (1) Determine the absorption spectrum of a solution of Amoxapine in 0.1 mol/L hydrochloric acid TS (1 in 50,000) as directed under Ultraviolet-visible Spectrophotometry <2.24>, and compare the spectrum with the Reference Spectrum: both spectra exhibit similar intensities of absorption as the same wavelengths.

(2) Determine the infrared absorption spectrum of Amoxapine, previously dried, as directed in the potassium bromide disk method under Infrared Spectrophotometry <2.25>, and compare the spectrum with the Reference Spectrum: both spectra exhibit similar intensities of absorption at the same wave numbers.

(3) Perform the test with Amoxapine as directed under Flame Coloration Test <1.04> (2): a green color appears.

Melting point <2.60> 178 – 182°C

Purity (1) Heavy metals <1.07>—Proceed with 2.0 g of Amoxapine according to Method 2, and perform the test. Prepare the control solution with 3.0 mL of Standard Lead Solution (not more than 15 ppm).

(2) Related substances—Dissolve 0.5 g of Amoxapine in 10 mL of a mixture of ethanol (95) and acetic acid (100) (9:1), and use this solution as the sample solution. Pipet 1 mL of the sample solution, and add a mixture of ethanol (95) and acetic acid (100) (9:1) to make exactly 10 mL. Pipet 1 mL of this solution, add a mixture of ethanol (95) and acetic acid (100) (9:1) to make exactly 20 mL, and use this solution as the standard solution. Perform the test with these solutions as directed under Thin-layer Chromatography <2.03>. Spot 5 μ L each of the sample solution and standard solution on a plate of silica gel with fluorescent indicator for thin-layer chromatography. Develop the plate with a mixture of ethanol (95) and acetic acid (100) (9:1) to a distance of about 10 cm, and air-dry the plate. Examine under ultraviolet light (main wavelength: 254 nm): the spots other than the principal spot obtained from the sample solution are not more intense than the spot from the standard solution.

Loss on drying <2.41> Not more than 0.4% (1 g, in vacuum, 60°C, 3 hours).

Residue on ignition <2.44> Not more than 0.1% (1 g).

Assay Weigh accurately about 0.3 g of Amoxapine, previ-

ously dried, dissolve in 50 mL of acetic acid (100), and titrate <2.50> with 0.1 mol/L perchloric acid VS until the color of the solution changes from purple through blue to greenish blue (indicator: 2 drops of crystal violet TS). Perform a blank determination in the same manner, and make any necessary correction.

Each mL of 0.1 mol/L perchloric acid VS
= 15.69 mg of $C_{17}H_{16}ClN_3O$

Containers and storage Containers—Tight containers.

Amoxicillin Hydrate

アモキシシリン水和物

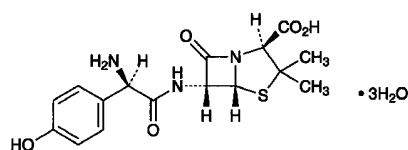

$C_{16}H_{19}N_3O_5S \cdot 3H_2O$: 419.45
(2*S*,5*R*,6*R*)-6-[(2*R*)-2-Amino-2-(4-hydroxyphenyl)-acetylamino]-3,3-dimethyl-7-oxo-4-thia-1-azabicyclo[3.2.0]heptane-2-carboxylic acid trihydrate
[61336-70-7]

Amoxicillin Hydrate contains not less than 950 μ g (potency) and not more than 1010 μ g (potency) per mg, calculated on the anhydrous basis. The potency of Amoxicillin Hydrate is expressed as mass (potency) of amoxicillin ($C_{16}H_{19}N_3O_5S$: 365.40).

Description Amoxicillin Hydrate occurs as white to light yellow-white, crystals or crystalline powder.

It is slightly soluble in water and in methanol, and very slightly soluble in ethanol (95).

Identification Determine the infrared absorption spectrum of Amoxicillin Hydrate as directed in the potassium bromide disk method under Infrared Spectrophotometry <2.25>, and compare the spectrum with the Reference Spectrum or the spectrum of Amoxicillin RS: both spectra exhibit similar intensities of absorption at the same wave numbers.

Optical rotation <2.49> $[\alpha]_D^{20}$: +290 – +315° (0.1 g calculated on the anhydrous basis, water, 100 mL, 100 mm).

Purity (1) Heavy metals <1.07>—To 1.0 g of Amoxicillin Hydrate add 2 mL of a solution of magnesium sulfate heptahydrate (1 in 4), mix, and heat on a water bath to dryness. Carbonize the residue by gently heating. After cooling, add 1 mL of sulfuric acid, heat carefully, then heat at 500 – 600°C to incinerate. After cooling, add 1 mL of hydrochloric acid to the residue, and heat on a water bath to dryness. Then add 10 mL of water to the residue, and heat on a water bath to dissolve. After cooling, add ammonia TS to adjust the pH to 3 – 4, and add 2 mL of dilute acetic acid. If necessary, filter, wash the residue on the filter with 10 mL of water, transfer the filtrate and washings into a Nessler tube, add water to make 50 mL, and use this solution as the test solution. Prepare the control solution as follows: To 2.0 mL of Standard Lead Solution add 2 mL of a solution of magnesium sulfate heptahydrate (1 in 4), then proceed in the same manner as for preparation of the test solution (not more than 20 ppm).

(2) Arsenic <1.11>—Prepare the test solution with 1.0 g of Amoxicillin Hydrate according to Method 4, and perform

the test (not more than 2 ppm).

(3) Related substances—Dissolve 0.10 g of Amoxicillin Hydrate in 50 mL of a solution of boric acid (1 in 200), and use this solution as the sample solution. Pipet 1 mL of the sample solution, add a solution of boric acid (1 in 200) to make exactly 100 mL, and use this solution as the standard solution. Perform the test with exactly 10 μ L each of the sample solution and standard solution as directed under Liquid Chromatography <2.01> according to the following conditions. Determine each peak area of both solutions by the automatic integration method: the area of the peak other than amoxicillin obtained from the sample solution is not larger than the peak area of amoxicillin from the standard solution. Furthermore, the total area of the peaks other than amoxicillin from the sample solution is not larger than 3 times the peak area of amoxicillin from the standard solution.

Operating conditions—

Detector: An ultraviolet absorption photometer (wavelength: 254 nm).

Column: A stainless steel column 4 mm in inside diameter and 30 cm in length, packed with octadecylsilanized silica gel for liquid chromatography (10 μ m in particle diameter).

Column temperature: A constant temperature of about 25°C.

Mobile phase: Dissolve 1.36 g of sodium acetate trihydrate in 750 mL of water, adjust to pH 4.5 with acetic acid (31), and add water to make 1000 mL. To 950 mL of this solution add 50 mL of methanol.

Flow rate: Adjust so that the retention time of amoxicillin is about 8 minutes.

Time span of measurement: About 4 times as long as the retention time of amoxicillin, beginning after the solvent peak.

System suitability—

Test for required detectability: To exactly 1 mL of the standard solution add a solution of boric acid (1 in 200) to make exactly 10 mL. Confirm that the peak area of amoxicillin obtained with 10 μ L of this solution is equivalent to 7 to 13% of that with 10 μ L of the standard solution.

System performance: When the procedure is run with 10 μ L of the standard solution under the above operating conditions, the number of theoretical plates and the symmetry factor of the peak of amoxicillin are not less than 2500 and not more than 1.5, respectively.

System repeatability: When the test is repeated 6 times with 10 μ L of the standard solution under the above operating conditions, the relative standard deviation of the peak area of amoxicillin is not more than 1.0%.

Water <2.48> Not less than 11.0% and not more than 15.0% (0.1 g, volumetric titration, direct titration).

Assay Weigh accurately an amount of Amoxicillin Hydrate and Amoxicillin RS, equivalent to about 30 mg (potency), dissolve each in a solution of boric acid (1 in 200) to make exactly 100 mL, and use these solutions as the sample solution and standard solution. Perform the test with exactly 10 μ L each of the sample solution and standard solution as directed under Liquid Chromatography <2.01> according to the following conditions, and calculate the peak areas, A_T and A_S , of amoxicillin in each solution.

Amount [μ g (potency)] of amoxicillin ($C_{16}H_{19}N_3O_5S$)
= $M_S \times A_T / A_S \times 1000$

M_S : Amount [mg (potency)] of Amoxicillin RS taken

Operating conditions—

Detector: An ultraviolet absorption photometer (wavelength: 230 nm).

Column: A stainless steel column 4.6 mm in inside diameter and 15 cm in length, packed with octadecylsilanized silica gel for liquid chromatography (5 μm in particle diameter).

Column temperature: A constant temperature of about 25°C.

Mobile phase: Dissolve 1.361 g of sodium acetate trihydrate in 750 mL of water, adjust to pH 4.5 with acetic acid (31), and add water to make 1000 mL. To 950 mL of this solution add 50 mL of methanol.

Flow rate: Adjust so that the retention time of amoxicillin is about 8 minutes.

System suitability—

System performance: When the procedure is run with 10 μL of the standard solution under the above operating conditions, the number of theoretical plates of the peak of amoxicillin is not less than 2500.

System repeatability: When the test is repeated 6 times with 10 μL of the standard solution under the above operating conditions, the relative standard deviation of the peak area of amoxicillin is not more than 1.0%.

Containers and storage Containers—Tight containers.

Amoxicillin Capsules

アモキシシリンカプセル

Amoxicillin Capsules contain not less than 92.0% and not more than 105.0% of the labeled potency of Amoxicillin ($\text{C}_{16}\text{H}_{19}\text{N}_3\text{O}_5\text{S}$; 365.40).

Method of preparation Prepare as directed under Capsules, with Amoxicillin Hydrate.

Identification Take out the contents of Amoxicillin Capsules, to a quantity of the contents, equivalent to 8 mg (potency) of Amoxicillin Hydrate, add 2 mL of 0.01 mol/L hydrochloric acid TS, shake for 30 minutes, filter, and use the filtrate as the sample solution. Separately, dissolve an amount equivalent to 8 mg (potency) of Amoxicillin RS in 2 mL of 0.01 mol/L hydrochloric acid TS, and use this solution as the standard solution. Perform the test with these solutions as directed under Thin-layer Chromatography <2.03>. Spot 5 μL each of the sample solution and standard solution on a plate of silica gel for thin-layer chromatography. Develop the plate with a mixture of tetrahydrofuran, water and formic acid (50:5:2) to a distance of about 10 cm, and air-dry the plate. Spray evenly a solution of ninhydrin in ethanol (95) (1 in 20) on the plate, and heat the plate at 110°C for 15 minutes; the principal spot obtained from the sample solution and the spot from the standard solution show a red-purple color and the same R_f value.

Purity Related substances—Take out the contents of Amoxicillin Capsules, to a quantity of the contents, equivalent to 0.1 g (potency) of Amoxicillin Hydrate, add 30 mL of a solution of boric acid (1 in 200), shake for 15 minutes, and add a solution of boric acid (1 in 200) to make 50 mL. Centrifuge this solution, and use the supernatant liquid as the sample solution. Pipet 1 mL of the sample solution, add a solution of boric acid (1 in 200) to make exactly 100 mL, and use this solution as the standard solution. Perform the test with exactly 10 μL each of the sample solution and standard solution as directed under Liquid Chromatography <2.01>

according to the following conditions. Determine each peak area of both solutions by the automatic integration method: the area of each peak other than amoxicillin obtained from the sample solution is not larger than the peak area of amoxicillin from the standard solution.

Operating conditions—

Proceed as directed in the operating conditions in the Purity (3) under Amoxicillin Hydrate.

System suitability—

Test for required detectability and system repeatability: Proceed as directed in the system suitability in the Purity (3) under Amoxicillin Hydrate.

System performance: When the procedure is run with 10 μL of the standard solution under the above operating conditions, the number of theoretical plates and the symmetry factor of the peak of amoxicillin is not less than 2500 and not more than 1.5, respectively.

Water <2.48> Not more than 15.0% (0.1 g, volumetric titration, direct titration).

Uniformity of dosage units <6.02> It meets the requirement of the Mass variation test.

Dissolution <6.10> When the test is performed at 100 revolutions per minute according to the Paddle method using the sinker, using 900 mL of water as the dissolution medium, the dissolution rate in 60 minutes of Amoxicillin Capsules is not less than 75%.

Start the test with 1 capsule of Amoxicillin Capsules, withdraw not less than 20 mL of the medium at the specified minute after starting the test, and filter through a membrane filter with a pore size not exceeding 0.45 μm . Discard not less than 10 mL of the first filtrate, pipet V mL of the subsequent filtrate, add water to make exactly V' mL so that each mL contains about 56 μg (potency) of Amoxicillin Hydrate, and use this solution as the sample solution. Separately, weigh accurately an amount equivalent to about 28 mg (potency) of Amoxicillin RS, dissolve in water to make exactly 100 mL. Pipet 5 mL of this solution, add water to make exactly 25 mL, and use this solution as the standard solution. Perform the test with exactly 50 μL each of the sample solution and standard solution as directed under Liquid Chromatography <2.01> according to the following conditions, and determine the peak areas, A_T and A_S , of amoxicillin in each solution.

$$\begin{aligned} &\text{Dissolution rate (\%)} \text{ with respect to the labeled amount} \\ &\text{of amoxicillin } (\text{C}_{16}\text{H}_{19}\text{N}_3\text{O}_5\text{S}) \\ &= M_S \times A_T/A_S \times V'/V \times 1/C \times 100 \end{aligned}$$

M_S : Amount [mg (potency)] of Amoxicillin RS taken
 C : Labeled amount [mg (potency)] of amoxicillin ($\text{C}_{16}\text{H}_{19}\text{N}_3\text{O}_5\text{S}$) in 1 capsule

Operating conditions—

Proceed as directed in the operating conditions in the Assay under Amoxicillin Hydrate.

System suitability—

System performance: When the procedure is run with 50 μL of the standard solution under the above operating conditions, the number of theoretical plates and the symmetry factor of the peak of amoxicillin are not less than 2500 and not more than 2.0, respectively.

System repeatability: When the test is repeated 6 times with 50 μL of the standard solution under the above operating conditions, the relative standard deviation of the peak area of amoxicillin is not more than 1.5%.

Assay Weigh accurately the mass of not less than 10 Amoxicillin Capsules, take out the contents, and weigh accu-

rately the mass of the emptied shells. Weigh accurately an amount equivalent to about 0.1 g (potency) of Amoxicillin Hydrate, add 70 mL of water, shake for 15 minutes, and add water to make exactly 100 mL. Centrifuge this solution, and use the supernatant liquid as the sample solution. Separately, weigh accurately an amount equivalent to about 20 mg (potency) of Amoxicillin RS, dissolve in water to make exactly 20 mL, and use this solution as the standard solution. Perform the test with exactly 10 μ L each of the sample solution and standard solution as directed under Liquid Chromatography <2.01> according to the following conditions, and determine the peak areas, A_T and A_S , of amoxicillin in each solution.

$$\begin{aligned} &\text{Amount [mg (potency)] of amoxicillin (C}_{16}\text{H}_{19}\text{N}_3\text{O}_5\text{S)} \\ &= M_S \times A_T / A_S \times 5 \end{aligned}$$

M_S : Amount [mg (potency)] of Amoxicillin RS taken

Operating conditions—

Column temperature, mobile phase, and flow rate: Proceed as directed in the operating conditions in the Assay under Amoxicillin Hydrate.

Detector: An ultraviolet absorption photometer (wavelength: 254 nm).

Column: A stainless steel column 4 mm in inside diameter and 30 cm in length, packed with octadecylsilanized silica gel for liquid chromatography (10 μ m in particle diameter).

System suitability—

System performance: When the procedure is run with 10 μ L of the standard solution under the above operating conditions, the number of theoretical plates and the symmetry factor of the peak of amoxicillin are not less than 2500 and not more than 1.5, respectively.

System repeatability: When the test is repeated 6 times with 10 μ L of the standard solution under the above operating conditions, the relative standard deviation of peak areas of amoxicillin is not more than 1.0%.

Containers and storage Containers—Tight containers.

Amphotericin B

アムホテリシン B

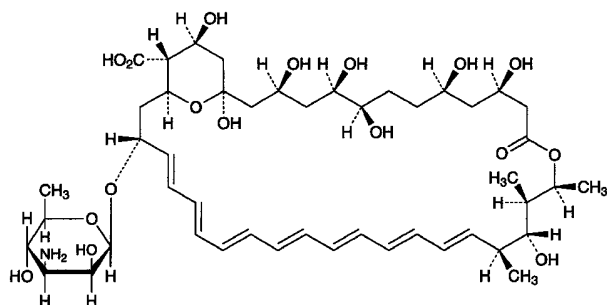

$C_{47}H_{73}NO_{17}$: 924.08
(1R,3S,5R,6R,9R,11R,15S,16R,17R,18S,19E,21E,23E,25E,27E,29E,31E,33R,35S,36R,37S)-33-(3-Amino-3,6-dideoxy- β -D-mannopyranosyloxy)-1,3,5,6,9,11,17,37-octahydroxy-15,16,18-trimethyl-13-oxo-14,39-dioxabicyclo[33.3.1]nonatriacontan-19,21,23,25,27,29,31-heptaene-36-carboxylic acid [1397-89-3]

Amphotericin B is a polyene macrolide substance having antifungal activity produced by the growth of *Streptomyces nodosus*.

It contains not less than 840 μ g (potency) per mg, calculated on the dried basis. The potency of Amphotericin B is expressed as mass (potency) of amphotericin B ($C_{47}H_{73}NO_{17}$).

Description Amphotericin B occurs as a yellow to orange powder.

It is freely soluble in dimethylsulfoxide and practically insoluble in water and in ethanol (95).

Identification (1) Dissolve 5 mg of Amphotericin B in 10 mL of dimethylsulfoxide. To 1 mL of this solution add 5 mL of phosphoric acid: a blue color develops between the two layers, and the solution becomes blue by shaking. After addition of 15 mL of water it becomes yellow to light yellow-brown by shaking.

(2) Dissolve 25 mg of Amphotericin B in 5 mL of dimethylsulfoxide, and add methanol to make 50 mL. To 1 mL of this solution add methanol to make 50 mL. Determine the absorption spectrum of this solution as directed under Ultraviolet-visible Spectrophotometry <2.24>, and compare the spectrum with the Reference Spectrum or the spectrum of a solution of Amphotericin B RS prepared in the same manner as the sample solution: both spectra exhibit similar intensities of absorption at the same wavelengths.

Purity Amphotericin A—Weigh accurately about 50 mg each of Amphotericin B and Amphotericin B RS, add exactly 10 mL each of dimethylsulfoxide to dissolve, and add methanol to make exactly 50 mL. Pipet 4 mL each of these solutions, add methanol to make exactly 50 mL, and use these solutions as the sample solution and standard solution (1), respectively. Separately, weigh accurately about 20 mg of Nystatin RS, add exactly 40 mL of dimethylsulfoxide to dissolve, then add methanol to make exactly 200 mL. Pipet 4 mL of this solution, add methanol to make exactly 50 mL, and use this solution as the standard solution (2). Perform the test with these solutions as directed under Ultraviolet-visible Spectrophotometry <2.24> using a solution obtained in the same manner as the sample solution as the blank, and determine the absorbances at 282 nm and at 304 nm. Calculate the amount of amphotericin A by the following equation: not more than 5% for Amphotericin B used for injections, and not more than 15% for Amphotericin B not used for injections.

Amount (%) of amphotericin A

$$= \frac{M_S \times \{(A_{Sa1} \times A_{T2}) - (A_{Sa2} \times A_{T1})\} \times 25}{M_T \times \{(A_{Sa1} \times A_{Sb2}) - (A_{Sa2} \times A_{Sb1})\}}$$

M_S : Amount (mg) of Nystatin RS taken

M_T : Amount (mg) of Amphotericin B taken

A_{Sa1} : Absorbance at 282 nm of the standard solution (1)

A_{Sb1} : Absorbance at 282 nm of the standard solution (2)

A_{Sa2} : Absorbance at 304 nm of the standard solution (1)

A_{Sb2} : Absorbance at 304 nm of the standard solution (2)

A_{T1} : Absorbance at 282 nm of the sample solution

A_{T2} : Absorbance at 304 nm of the sample solution

Loss on drying <2.41> Not more than 5.0% (0.1 g, in vacuum, 60°C, 3 hours).

Assay Perform the test according to the Cylinder-plate method as directed under Microbial Assay for Antibiotics <4.02> according to the following conditions.

(i) Test organism—*Saccharomyces cerevisiae* ATCC 9763

(ii) Culture medium—Use the medium 2) under (1) Agar media for seed and base layer.

(iii) Preparation of cylinder-agar plate—Proceed as di-

rected in 1.5 Preparation of agar base layer plates under the Cylinder plate method, using Petri dish plates not dispensing the agar medium for base layer and dispensing 8.0 mL of the seeded agar medium.

(iv) Standard solution—Use light-resistant vessels. Weigh accurately an amount of Amphotericin B RS equivalent to about 20 mg (potency), dissolve in dimethylsulfoxide to make exactly 20 mL, and use this solution as the standard stock solution. Keep the standard stock solution at 5°C or below and use within 24 hours. Take exactly a suitable amount of the standard stock solution before use, and add dimethylsulfoxide to make solutions so that each mL contains 200 µg (potency) and 50 µg (potency). Pipet 1 mL each of these solutions, add 0.2 mol/L phosphate buffer solution (pH 10.5) to make exactly 20 mL, and use these solutions as the high concentration standard solution and low concentration standard solution, respectively.

(v) Sample solution—Use light-resistant vessels. Weigh accurately an amount of Amphotericin B equivalent to about 20 mg (potency), dissolve in dimethylsulfoxide to make exactly 20 mL, and use this solution as the sample stock solution. Take exactly a suitable amount of the sample stock solution, add dimethylsulfoxide to make solutions so that each mL contains 200 µg (potency) and 50 µg (potency). Pipet 1 mL each of these solutions, add 0.2 mol/L phosphate buffer solution (pH 10.5) to make exactly 20 mL, and use these solutions as the high concentration sample solution and low concentration sample solution, respectively.

Containers and storage Containers—Tight containers.

Storage—Light-resistant, and in a cold place.

Amphotericin B for Injection

注射用アムホテリシン B

Amphotericin B for Injection is a preparation for injection which is dissolved before use.

It contains not less than 90.0% and not more than 120.0% of the labeled potency of amphotericin B (C₄₇H₇₃NO₁₇: 924.08).

Method of preparation Prepare as directed under Injections, with Amphotericin B.

Description Amphotericin B for Injection occurs as yellow to orange, powder or masses.

Identification To an amount of Amphotericin B for Injection, equivalent to 25 mg (potency) of Amphotericin B, add 5 mL of dimethylsulfoxide and 45 mL of methanol, and shake. To 1 mL of this solution add methanol to make 50 mL, and filter if necessary. Determine the absorption spectrum of the solution as directed under Ultraviolet-visible Spectrophotometry <2.24>: it exhibits maxima between 361 nm and 365 nm, between 380 nm and 384 nm and between 403 nm and 407 nm.

pH <2.54> Dissolve an amount of Amphotericin B for Injection, equivalent to 50 mg (potency) of Amphotericin B, in 10 mL of water. To 1 mL of this solution add water to make 50 mL: 7.2 – 8.0.

Purity Clarity and color of solution—Dissolve an amount of Amphotericin B for Injection, equivalent to 50 mg (potency) of Amphotericin B, in 10 mL of water: the solution is clear and yellow to orange.

Loss on drying <2.41> Not more than 8.0% (0.3 g, in vacu-

um, 60°C, 3 hours).

Bacterial endotoxins <4.01> Less than 3.0 EU/mg (potency).

Uniformity of dosage units <6.02> It meets the requirement of the Mass variation test (*T*: 105.0%).

Foreign insoluble matter <6.06> Perform the test according to Method 2: it meets the requirement.

Insoluble particulate matter <6.07> It meets the requirement.

Sterility <4.06> Perform the test according to the Membrane filtration method: it meets the requirement.

Assay Perform the test according to the Cylinder-plate method as directed under Microbial Assay for Antibiotics <4.02> according to the following conditions.

(i) Test organism, culture medium, preparation of cylinder-agar plate and standard solutions—Proceed as directed in the Assay under Amphotericin B.

(ii) Sample solutions—Prepare using light-resistant containers. Weigh accurately an amount of Amphotericin B for Injection, equivalent to about 50 mg (potency), dissolve in dimethylsulfoxide to make exactly 50 mL, and use this solution as the sample stock solution. Measure exactly a suitable quantity of the sample stock solution, add dimethylsulfoxide to make solutions so that each mL contains about 200 µg (potency) and 50 µg (potency). Pipet 1 mL each of these solutions, add 0.2 mol/L phosphate buffer solution (pH 10.5) to make exactly 20 mL, and use these solutions as the high concentration sample solution and low concentration sample solution, respectively.

Containers and storage Containers—Hermetic containers.

Storage—Light-resistant, at a cold place.

Amphotericin B Syrup

アムホテリシン B シロップ

Amphotericin B Syrup contain not less than 90.0% and not more than 115.0% of the labeled potency of amphotericin B (C₄₇H₇₃NO₁₇: 924.08).

Method of preparation Prepare as directed under Syrup, with Amphotericin B.

Identification To an amount of Amphotericin B Syrup, equivalent to 25 mg (potency) of Amphotericin B, add 5 mL of dimethylsulfoxide and 45 mL of methanol, and shake. To 1 mL of this solution add methanol to make 50 mL, and filter, if necessary. Determine the absorption spectrum of the solution as directed under Ultraviolet-visible Spectrophotometry <2.24>: it exhibits maxima between 361 nm and 365 nm, between 380 nm and 384 nm and between 403 nm and 407 nm.

pH <2.54> 5.0 – 7.0

Microbial limit <4.05> The acceptance criteria of TAMC and TYMC are 10² CFU/mL and 5 × 10¹ CFU/mL, respectively.

Assay Perform the test according to the Cylinder-plate method as directed under Microbial Assay for Antibiotics <4.02> according to the following conditions.

(i) Test organism, culture medium, preparation of cylinder-agar plate and standard solutions—Proceed as directed

in the Assay under Amphotericin B.

(ii) Sample solutions—Prepare using light-resistant containers. Weigh accurately an amount of Amphotericin B Syrup, equivalent to about 0.1 g (potency), add about 70 mL of dimethylsulfoxide, shake, then add dimethylsulfoxide to make exactly 100 mL, and use this solution as the sample stock solution. Measure exactly a suitable amount of the sample stock solution, add dimethylsulfoxide to make solutions so that each mL contains about 200 μ g (potency) and 50 μ g (potency). Pipet 1 mL each of these solutions, add 0.2 mol/L phosphate buffer solution (pH 10.5) to make exactly 20 mL, and use these solutions as the high concentration sample solution and low concentration sample solution, respectively.

Containers and storage Containers—Tight containers.

Storage—Light-resistant.

Amphotericin B Tablets

アムホテリシン B 錠

Amphotericin B Tablets contain not less than 90.0% and not more than 120.0% of the labeled potency of amphotericin B (C₄₇H₇₃NO₁₇: 924.08).

Method of preparation Prepare as directed under Tablets, with Amphotericin B.

Identification To an amount of pulverized Amphotericin B Tablets, equivalent to 25 mg (potency) of Amphotericin B, add 5 mL of dimethylsulfoxide and 45 mL of methanol, and shake. To 1 mL of this solution add methanol to make 50 mL, and filter, if necessary. Determine the absorption spectrum of the solution as directed under Ultraviolet-visible Spectrophotometry <2.24>: it exhibits maxima between 361 nm and 365 nm, between 380 nm and 384 nm and between 403 nm and 407 nm.

Loss on drying <2.41> Not more than 5.0% (0.3 g, in vacuum, 60°C, 3 hours).

Uniformity of dosage units <6.02> It meets the requirement of the Mass variation test (*T*: 105.0%).

Disintegration <6.09> Perform the test using the disk: it meets the requirement.

Assay Perform the test according to the Cylinder-plate method as directed under Microbial Assay for Antibiotics <4.02> according to the following conditions.

(i) Test organism, culture medium, preparation of cylinder-agar plate and standard solutions—Proceed as directed in the Assay under Amphotericin B.

(ii) Sample solutions—Prepare using light-resistant containers. Weigh accurately and powder not less than 20 tablets of Amphotericin B Tablets. Weigh accurately a part of the powder, equivalent to about 0.1 g (potency), add about 70 mL of dimethylsulfoxide, shake, then add dimethylsulfoxide to make exactly 100 mL, centrifuge, and use the supernatant liquid as the sample stock solution. Measure exactly a suitable amount of the sample stock solution, add dimethylsulfoxide to make solutions so that each mL contains 200 μ g (potency) and 50 μ g (potency). Pipet 1 mL each of these solutions, add 0.2 mol/L phosphate buffer solution (pH 10.5) to make exactly 20 mL, and use these solutions as the high concentration sample solution and low concentration sample solution, respectively.

Containers and storage Containers—Well-closed containers.

Anhydrous Ampicillin

無水アンピシリン

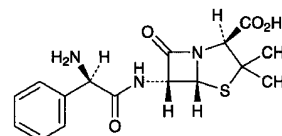

C₁₆H₁₉N₃O₄S: 349.40

(2*S*,5*R*,6*R*)-6-[(2*R*)-2-Amino-2-phenylacetylamino]-3,3-dimethyl-7-oxo-4-thia-1-azabicyclo[3.2.0]heptane-2-carboxylic acid
[69-53-4]

Anhydrous Ampicillin contains not less than 960 μ g (potency) and not more than 1005 μ g (potency) per mg, calculated on the anhydrous basis. The potency of Anhydrous Ampicillin is expressed as mass (potency) of ampicillin (C₁₆H₁₉N₃O₄S).

Description Anhydrous Ampicillin occurs as white to light yellow-white, crystals or crystalline powder.

It is sparingly soluble in water, slightly soluble in methanol, very slightly soluble in ethanol (95), and practically insoluble in acetonitrile.

Identification Determine the infrared absorption spectrum of Anhydrous Ampicillin as directed in the potassium bromide disk method under Infrared Spectrophotometry <2.25>, and compare the spectrum with the Reference Spectrum: both spectra exhibit similar intensities of absorption at the same wave numbers.

Optical rotation <2.49> [α]_D²⁰: +280 – +305° (0.5 g calculated on the anhydrous basis, water, 100 mL, 100 mm).

pH <2.54> The pH of a solution obtained by dissolving 1.0 g of Anhydrous Ampicillin in 100 mL of water is between 4.0 and 5.5.

Purity (1) Heavy metals <1.07>—Proceed with 1.0 g of Anhydrous Ampicillin according to Method 2, and perform the test. Prepare the control solution with 2.0 mL of Standard Lead Solution (not more than 20 ppm).

(2) Arsenic <1.11>—Prepare the test solution with 1.0 g of Anhydrous Ampicillin according to Method 3, and perform the test (not more than 2 ppm).

(3) Related substances—Dissolve 0.05 g of Anhydrous Ampicillin in the mobile phase to make 50 mL, and use this solution as the sample solution. Pipet 1 mL of the sample solution, add the mobile phase to make exactly 100 mL, and use this solution as the standard solution. Perform the test with exactly 10 μ L each of the sample solution and standard solution as directed under Liquid Chromatography <2.01> according to the following conditions, and determine each peak area by the automatic integration method: the area of each peak other than ampicillin obtained from the sample solution is not larger than the peak area of ampicillin from the standard solution.

Operating conditions—

Detector, column, column temperature, mobile phase, and flow rate: Proceed as directed in the operating conditions in the Assay.

Time span of measurement: As long as about 10 times of

the retention time of ampicillin.

System suitability—

System performance, and system repeatability: Proceed as directed in the system suitability in the Assay.

Test for required detectability: To exactly 1 mL of the standard solution add the mobile phase to make exactly 10 mL. Confirm that the peak area of ampicillin obtained with 10 μ L of this solution is equivalent to 7 to 13% of that with 10 μ L of the standard solution.

Water <2.48> Not more than 2.0% (2.5 g, volumetric titration, direct titration).

Assay Weigh accurately an amount of Anhydrous Ampicillin and Ampicillin RS, equivalent to about 50 mg (potency), add exactly 5 mL each of the internal standard solution and the mobile phase to make 50 mL, and use these solutions as the sample solution and standard solution. Perform the test with 10 μ L each of the sample solution and standard solution as directed under Liquid Chromatography <2.01> according to the following conditions, and calculate the ratios, Q_T and Q_S , of the peak area of ampicillin to that of the internal standard.

$$\begin{aligned} & \text{Amount } [\mu\text{g (potency)}] \text{ of ampicillin (C}_{16}\text{H}_{19}\text{N}_3\text{O}_4\text{S)} \\ & = M_S \times Q_T / Q_S \times 1000 \end{aligned}$$

M_S : Amount [mg (potency)] of Ampicillin RS taken

Internal standard solution—A solution of guaifenesin in the mobile phase (1 in 200).

Operating conditions—

Detector: An ultraviolet absorption photometer (wavelength: 230 nm).

Column: A stainless steel column 4.6 mm in inside diameter and 15 cm in length, packed with octadecylsilanized silica gel for liquid chromatography (5 μ m in particle diameter).

Column temperature: A constant temperature of about 25°C.

Mobile phase: Dissolve 5.94 g of diammonium hydrogen phosphate in 850 mL of water, add 100 mL of acetonitrile, adjust the pH to 5.0 with phosphoric acid, and add water to make exactly 1000 mL.

Flow rate: Adjust so that the retention time of ampicillin is about 6 minutes.

System suitability—

System performance: When the procedure is run with 10 μ L of the standard solution under the above operating conditions, ampicillin and the internal standard are eluted in this order with the resolution between these peaks being not less than 40.

System repeatability: When the test is repeated 6 times with 10 μ L of the standard solution under the above operating conditions, the relative standard deviation of the ratios of the peak area of ampicillin to that of the internal standard is not more than 1.0%.

Containers and storage Containers—Tight containers.

Ampicillin Hydrate

アンピシリン水和物

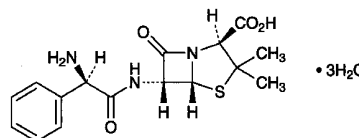

$\text{C}_{16}\text{H}_{19}\text{N}_3\text{O}_4\text{S} \cdot 3\text{H}_2\text{O}$: 403.45
(2*S*,5*R*,6*R*)-6-[(2*R*)-2-Amino-2-phenylacetyl-amino]-3,3-dimethyl-7-oxo-4-thia-1-azabicyclo[3.2.0]heptane-2-carboxylic acid trihydrate
[7177-48-2]

Ampicillin Hydrate contains not less than 960 μ g (potency) and not more than 1005 μ g (potency) per mg, calculated on the anhydrous basis. The potency of Ampicillin Hydrate is expressed as mass (potency) of ampicillin ($\text{C}_{16}\text{H}_{19}\text{N}_3\text{O}_4\text{S}$: 349.40).

Description Ampicillin Hydrate occurs as a white to light yellow-white, crystals or crystalline powder.

It is sparingly soluble in water, slightly soluble in methanol, very slightly soluble in ethanol (95), and practically insoluble in acetonitrile.

Identification Determine the infrared absorption spectrum of Ampicillin Hydrate as directed in the potassium bromide disk method under Infrared Spectrophotometry <2.25>, and compare the spectrum with the Reference Spectrum or the spectrum of Ampicillin RS: both spectra exhibit similar intensities of absorption at the same wave numbers.

Optical rotation <2.49> $[\alpha]_D^{20}$: +280 – +305° (0.5 g calculated on the anhydrous basis, water, 100 mL, 100 mm).

pH <2.54> The pH of a solution obtained by dissolving 1.0 g of Ampicillin Hydrate in 400 mL of water is between 3.5 and 5.5.

Purity (1) Heavy metals <1.07>—Proceed with 1.0 g of Ampicillin Hydrate according to Method 2, and perform the test. Prepare the control solution with 2.0 mL of Standard Lead Solution (not more than 20 ppm).

(2) Arsenic <1.11>—Prepare the test solution with 1.0 g of Ampicillin hydrate according to Method 3, and perform the test (not more than 2 ppm).

(3) Related substances—Dissolve 50 mg of Ampicillin Hydrate in 50 mL of the mobile phase, and use this solution as the sample solution. Pipet 1 mL of the sample solution, add the mobile phase to make exactly 100 mL, and use this solution as the standard solution. Perform the test with exactly 10 μ L each of the sample solution and standard solution as directed under Liquid Chromatography <2.01> according to the following conditions, and determine each peak area by the automatic integration method: the area of the peak other than ampicillin obtained from the sample solution is not larger than the peak area of ampicillin from the standard solution, and the total area of the peaks other than ampicillin from the sample solution is not larger than 2 times the peak area of ampicillin from the standard solution.

Operating conditions—

Detector, column, column temperature, mobile phase, and flow rate: Proceed as directed in the operating conditions in the Assay.

Time span of measurement: About 10 times as long as the retention time of ampicillin.

System suitability—

Test for required detectability: Pipet 1 mL of the standard solution, and add the mobile phase to make exactly 10 mL. Confirm that the peak area of ampicillin obtained with 10 μ L of this solution is equivalent to 7 to 13% of that with 10 μ L of the standard solution.

System performance: When the procedure is run with 10 μ L of the standard solution under the above operating conditions, the number of theoretical plates and the symmetry factor of the peak of ampicillin are not less than 5000 and not more than 1.5, respectively.

System repeatability: When the test is repeated 6 times with 10 μ L of the standard solution under the above operating conditions, the relative standard deviation of the peak area of ampicillin is not more than 1.0%.

(4) *N,N*-Dimethylaniline—Weigh accurately about 1 g of Ampicillin Hydrate, dissolve in 5 mL of sodium hydroxide TS, add exactly 1 mL of the internal standard solution, shake vigorously for 1 minute, and use the upper layer liquid obtained after allowing it to stand as the sample solution. Separately, weigh accurately about 50 mg of *N,N*-dimethylaniline, dissolve in 2 mL of hydrochloric acid and 20 mL of water, add water to make exactly 50 mL, and use this solution as the standard stock solution. Pipet 5 mL of the standard stock solution, and add water to make exactly 250 mL. Pipet 1 mL of this solution, add 5 mL of sodium hydroxide TS and exactly 1 mL of the internal standard solution, shake vigorously for 1 minute, and use the upper layer liquid obtained after allowing it to stand as the standard solution. Perform the test with 1 μ L each of the sample solution and standard solution as directed under Gas Chromatography <2.02> according to the following conditions, calculate the ratios, Q_T and Q_S , of the peak area of *N,N*-dimethylaniline to that of the internal standard, and calculate the amount of *N,N*-dimethylaniline by the following equation: not more than 20 ppm.

$$\begin{aligned} \text{Amount (ppm) of } N,N\text{-dimethylaniline} \\ = M_S/M_T \times Q_T/Q_S \times 400 \end{aligned}$$

M_S : Amount (g) of *N,N*-dimethylaniline taken

M_T : Amount (g) of Ampicillin Hydrate taken

Internal standard solution—A solution of naphthalene in cyclohexane (1 in 20,000).

Operating conditions—

Detector: A hydrogen flame-ionization detector.

Column: A glass column 2.6 mm in inside diameter and 2 m in length, packed with siliceous earth for gas chromatography (180–250 μ m in particle diameter) coated with 50% phenyl-50% methyl polysiloxane for gas chromatography at the ratio of 3%.

Column temperature: A constant temperature of about 120°C.

Carrier gas: Helium.

Flow rate: Adjust so that the retention time of *N,N*-dimethylaniline is about 5 minutes.

System suitability—

Test for required detectability: Measure exactly 1 mL of the standard stock solution, and add water to make exactly 250 mL. Pipet 1 mL of this solution, add 5 mL of sodium hydroxide TS and exactly 1 mL of the internal standard solution, shake vigorously for 1 minute, and use the upper layer liquid obtained after allowing it to stand for the test. Confirm that when the procedure is run with 1 μ L of the upper layer liquid under the above operating conditions, the ratio of the peak area of *N,N*-dimethylaniline to that of the internal standard is equivalent to 15 to 25% of the ratio of the

peak area of *N,N*-dimethylaniline to that of the internal standard with the standard solution.

System performance: Dissolve 50 mg of *N,N*-dimethylaniline in cyclohexane to make 50 mL. To 1 mL of this solution add the internal standard solution to make 50 mL, and use this solution as the solution for system suitability test. When the procedure is run with 1 μ L of the solution for system suitability test under the above operating conditions, *N,N*-dimethylaniline and the internal standard are eluted in this order with the resolution between these peaks being not less than 3.

System repeatability: When the test is repeated 6 times with 1 μ L of the solution for system suitability test under the above operating conditions, the relative standard deviation of the ratios of the peak area of *N,N*-dimethylaniline to that of the internal standard is not more than 2.0%.

Water <2.48> 12.0–15.0% (0.1 g, volumetric titration, direct titration).

Assay Weigh accurately an amount of Ampicillin Hydrate and Ampicillin RS, equivalent to about 50 mg (potency), dissolve in a suitable volume of the mobile phase, add exactly 5 mL each of the internal standard solution and the mobile phase to make 50 mL, and use these solutions as the sample solution and standard solution. Perform the test with 10 μ L each of the sample solution and standard solution as directed under Liquid Chromatography <2.01> according to the following conditions, and calculate the ratios, Q_T and Q_S , of the peak area of ampicillin to that of the internal standard.

$$\begin{aligned} \text{Amount } [\mu\text{g (potency)}] \text{ of ampicillin (C}_{16}\text{H}_{19}\text{N}_3\text{O}_4\text{S)} \\ = M_S \times Q_T/Q_S \times 1000 \end{aligned}$$

M_S : Amount [mg (potency)] of Ampicillin RS taken

Internal standard solution—A solution of guaifenesin in the mobile phase (1 in 200).

Operating conditions—

Detector: An ultraviolet absorption photometer (wavelength: 230 nm).

Column: A stainless steel column 4.6 mm in inside diameter and 15 cm in length, packed with octadecylsilanized silica gel for liquid chromatography (5 μ m in particle diameter).

Column temperature: A constant temperature of about 25°C.

Mobile phase: Dissolve 5.94 g of diammonium hydrogenphosphate in 850 mL of water, add 100 mL of acetonitrile, adjust the pH to 5.0 with phosphoric acid, and add water to make exactly 1000 mL.

Flow rate: Adjust so that the retention time of ampicillin is about 6 minutes.

System suitability—

System performance: When the procedure is run with 10 μ L of the standard solution under the above operating conditions, ampicillin and the internal standard are eluted in this order with the resolution between these peaks being not less than 40.

System repeatability: When the test is repeated 6 times with 10 μ L of the standard solution under the above operating conditions, the relative standard deviation of the ratios of the peak area of ampicillin to that of the internal standard is not more than 1.0%.

Containers and storage Containers—Tight containers.

Ampicillin Sodium

アンピシリンナトリウム

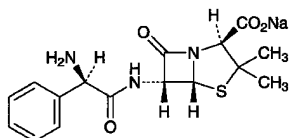

$C_{16}H_{18}N_3NaO_4S$: 371.39

Monosodium (2*S*,5*R*,6*R*)-6-[(2*R*)-2-amino-2-phenylacetamino]-3,3-dimethyl-7-oxo-4-thia-1-azabicyclo[3.2.0]heptane-2-carboxylate
[69-52-3]

Ampicillin Sodium contains not less than 850 μ g (potency) and not more than 950 μ g (potency) per mg, calculated on the anhydrous basis. The potency of Ampicillin Sodium is expressed as mass (potency) of ampicillin ($C_{16}H_{19}N_3O_4S$: 349.40).

Description Ampicillin Sodium occurs as white to light yellow-white, crystals or crystalline powder.

It is very soluble in water, and sparingly soluble in ethanol (99.5).

Identification (1) Determine the infrared absorption spectrum of Ampicillin Sodium, previously dried in a desiccator (reduced pressure not exceeding 0.67 kPa, 60°C) for 3 hours, as directed in the potassium bromide disk method under Infrared Spectrophotometry <2.25>, and compare the spectrum with the Reference Spectrum: both spectra exhibit similar intensities of absorption at the same wave numbers.

(2) Ampicillin Sodium responds to Qualitative Tests <1.09> (1) for sodium salt.

Optical rotation <2.49> $[\alpha]_D^{20}$: +246 – +272° (1 g calculated on the anhydrous basis, water, 100 mL, 100 mm).

pH <2.54> The pH of a solution obtained by dissolving 1.0 g of Ampicillin Sodium in 10 mL of water is between 8.0 and 10.0.

Purity (1) Clarity and color of solution—Dissolve 0.25 g (potency) of Ampicillin Sodium in 0.75 mL of water: the solution is clear, and its absorbance at 400 nm, determined as directed under Ultraviolet-visible Spectrophotometry <2.24>, is not more than 0.40.

(2) Heavy metals <1.07>—Proceed with 1.0 g of Ampicillin Sodium according to Method 1, and perform the test. Prepare the control solution with 2.0 mL of Standard Lead Solution (not more than 20 ppm).

(3) Arsenic <1.11>—Prepare the test solution with 1.0 g of Ampicillin Sodium according to Method 1, and perform the test (not more than 2 ppm).

(4) Related substances—Dissolve 50 mg of Ampicillin Sodium in 50 mL of the mobile phase, and use this solution as the sample solution. Pipet 1 mL of the sample solution, add the mobile phase to make exactly 100 mL, and use this solution as the standard solution. Perform the test with exactly 10 μ L each of the sample solution and standard solution as directed under Liquid Chromatography <2.01> according to the following conditions, and determine each peak area by the automatic integration method: the area of the peaks other than ampicillin obtained from the sample solution is not larger than the peak area of ampicillin from the standard solution.

Operating conditions—

Detector, column, column temperature, mobile phase, and flow rate: Proceed as directed in the operating conditions in the Assay.

Time span of measurement: About 10 times as long as the retention time of ampicillin.

System suitability—

Test for required detectability: Measure exactly 1 mL of the standard solution, and add the mobile phase to make exactly 10 mL. Confirm that the peak area of ampicillin obtained with 10 μ L of this solution is equivalent to 7 to 13% of that with 10 μ L of the standard solution.

System performance: Dissolve 50 mg of Ampicillin RS in a suitable amount of the mobile phase, add 5 mL of a solution of guaifenesin in the mobile phase (1 in 200) and the mobile phase to make 50 mL, and use this solution as the solution for system suitability test. When the procedure is run with 10 μ L of the solution for system suitability test under the above operating conditions, ampicillin and guaifenesin are eluted in this order with the resolution between these peaks being not less than 35.

System repeatability: When the test is repeated 6 times with 10 μ L of the solution for system suitability test under the above operating conditions, the relative standard deviation of the peak area of ampicillin is not more than 1.0%.

Water <2.48> Not more than 2.0% (0.2 g, volumetric titration, direct titration).

Assay Weigh accurately an amount of Ampicillin Sodium and Ampicillin RS, equivalent to about 50 mg (potency), dissolve them in a suitable amount of the mobile phase, add exactly 5 mL of the internal standard solution, then add the mobile phase to make 50 mL, and use these solutions as the sample solution and the standard solution, respectively. Perform the test with 10 μ L each of the sample solution and standard solution as directed under Liquid Chromatography <2.01> according to the following conditions, and calculate the ratios, Q_T and Q_S , of the peak area of ampicillin to that of the internal standard.

$$\begin{aligned} \text{Amount } [\mu\text{g (potency)}] \text{ of ampicillin } (C_{16}H_{19}N_3O_4S) \\ = M_S \times Q_T / Q_S \times 1000 \end{aligned}$$

M_S : Amount [mg (potency)] of Ampicillin RS taken

Internal standard solution—A solution of guaifenesin in the mobile phase (1 in 200).

Operating conditions—

Detector: An ultraviolet absorption photometer (wavelength: 230 nm).

Column: A stainless steel column 4.6 mm in inside diameter and 15 cm in length, packed with octadecylsilanized silica gel for liquid chromatography (5 μ m in particle diameter).

Column temperature: A constant temperature of about 25°C.

Mobile phase: Dissolve 5.94 g of diammonium hydrogen phosphate in 850 mL of water, add 100 mL of acetonitrile, adjust to pH 5.0 with phosphoric acid, and add water to make 1000 mL.

Flow rate: Adjust so that the retention time of ampicillin is about 6 minutes.

System suitability—

System performance: When the procedure is run with 10 μ L of the standard solution under the above operating conditions, ampicillin and guaifenesin are eluted in this order with the resolution between these peaks being not less than 35.

System repeatability: When the test is repeated 6 times

with 10 μL of the standard solution under the above operating conditions, the relative standard deviation of the ratio of the peak area of ampicillin to that of the internal standard is not more than 1.0%.

Containers and storage Containers—Tight containers.

Ampicillin Sodium for Injection

注射用アンピシリンナトリウム

Ampicillin Sodium for Injection is a preparation for injection which is dissolved before use.

It contains not less than 90.0% and not more than 110.0% of the labeled potency of ampicillin ($\text{C}_{16}\text{H}_{19}\text{N}_3\text{O}_4\text{S}$; 349.40).

Method of preparation Prepare as directed under Injections, with Ampicillin Sodium.

Description Ampicillin Sodium for Injection occurs as white to light yellow-white, crystals or crystalline powder.

Identification Proceed as directed in the Identification (1) under Ampicillin Sodium.

Osmotic pressure ratio Being specified separately when the drug is granted approval based on the Law.

pH <2.54> The pH of a solution prepared by dissolving an amount of Ampicillin Sodium for Injection, equivalent to 1.0 g (potency) of Ampicillin Sodium, in 10 mL of water is 8.0 to 10.0.

Purity Clarity and color of solution—Dissolve an amount of Ampicillin Sodium for Injection, equivalent to 0.25 g (potency) of Ampicillin Sodium, in 0.75 mL of water: the solution is clear. Perform the test with the solution as directed under Ultraviolet-visible Spectrophotometry <2.24>: the absorbance at 400 nm is not more than 0.40.

Water <2.48> Not more than 3.0% (0.2 g, volumetric titration, direct titration).

Bacterial endotoxins <4.01> Less than 0.075 EU/mg (potency).

Uniformity of dosage units <6.02> It meets the requirement of the Mass variation test.

Foreign insoluble matter <6.06> Perform the test according to Method 2: it meets the requirement.

Insoluble particulate matter <6.07> It meets the requirement.

Sterility <4.06> Perform the test according to the Membrane filtration method: it meets the requirement.

Assay Weigh accurately the mass of the contents of not less than 10 containers of Ampicillin Sodium for Injection. Weigh accurately an amount of a portion of the contents, equivalent to about 50 mg (potency) of Ampicillin Sodium, add exactly 5 mL of the internal standard solution and dissolve. Then add the mobile phase to make 50 mL, and use this solution as the sample solution. Separately, weigh accurately an amount of Ampicillin RS, equivalent to about 50 mg (potency), add exactly 5 mL of the internal standard solution and dissolve. Then add the mobile phase to make 50 mL, and use this solution as the standard solution. Perform the test with 10 μL each of the sample solution and standard solution as directed under Liquid Chromatography <2.01>

according to the following conditions, and calculate the ratios, Q_T and Q_S , of the peak area of ampicillin to that of the internal standard.

$$\begin{aligned} \text{Amount [mg (potency)] of ampicillin (C}_{16}\text{H}_{19}\text{N}_3\text{O}_4\text{S)} \\ = M_S \times Q_T / Q_S \end{aligned}$$

M_S : Amount [mg (potency)] of Ampicillin RS taken

Internal standard solution—A solution of guaifenesin in the mobile phase (1 in 200).

Operating conditions—

Detector: An ultraviolet absorption photometer (wavelength: 230 nm).

Column: A stainless steel column 4.6 mm in inside diameter and 15 cm in length, packed with octadecylsilanized silica gel for liquid chromatography (5 μm in particle diameter).

Column temperature: A constant temperature of about 25°C.

Mobile phase: Dissolve 5.94 mg of diammonium hydrogen phosphate in 850 mL of water, add 100 mL of acetonitrile, add phosphoric acid to adjust the pH to 5.0, then add water to make exactly 1000 mL.

Flow rate: Adjust so that the retention time of ampicillin is about 6 minutes.

System suitability—

System performance: When the procedure is run with 10 μL of the standard solution under the above operating conditions, ampicillin and the internal standard are eluted in this order with the resolution between these peaks being not less than 26.

System repeatability: When the test is repeated 6 times with 10 μL of the standard solution under the above operating conditions, the relative standard deviation of the ratio of the peak area of ampicillin to that of the internal standard is not more than 1.0%.

Containers and storage Containers—Hermetic containers.

Ampicillin Sodium and Sulbactam Sodium for Injection

注射用アンピシリンナトリウム・スルバクタムナトリウム

Ampicillin Sodium and Sulbactam Sodium for Injection is a preparation for injection which is dissolved before use.

It contains not less than 95.0% and not more than 112.0% of the labeled potency of ampicillin ($\text{C}_{16}\text{H}_{19}\text{N}_3\text{O}_4\text{S}$; 349.40) and sulbactam ($\text{C}_8\text{H}_{11}\text{NO}_5\text{S}$; 233.24).

Method of preparation Prepare as directed under Injections, with Ampicillin Sodium and Sulbactam Sodium.

Description Ampicillin Sodium and Sulbactam Sodium for Injection occurs as a white to yellowish white powder.

Identification (1) The retention times of ampicillin obtained from the sample solution and the standard solution observed in the Assay are the same, and the peak area of ampicillin observed in the Assay obtained from the sample solution is 2.8 to 3.6 times the peak area of ampicillin observed in the test performed with 10 μL of the sample solution obtained in the Assay as directed under Liquid Chromatography <2.01> according to the following conditions.

Operating conditions—

Column, column temperature, mobile phase, and flow

rate: Proceed as directed in the operating conditions in the Assay.

Detector: An ultraviolet absorption photometer (wavelength: 230 nm).

System suitability—

System performance: Proceed as directed in the system suitability in the Assay.

(2) The retention times of sulbactam obtained from the sample solution and the standard solution observed in the Assay are the same, and the peak area of sulbactam observed in the Assay obtained from the sample solution is 2.0 to 2.6 times the peak area of sulbactam observed in the test performed with 10 μ L of the sample solution obtained in the Assay as directed under Liquid Chromatography <2.01> according to the following conditions.

Operating conditions—

Column, column temperature, mobile phase, and flow rate: Proceed as directed in the operating conditions in the Assay.

Detector: An ultraviolet absorption photometer (wavelength: 230 nm).

System suitability—

System performance: Proceed as directed in the system suitability in the Assay.

pH <2.54> The pH of a solution prepared by dissolving an amount of Ampicillin Sodium and Sulbactam Sodium for Injection, equivalent to 1.0 g (potency) of ampicillin ($C_{16}H_{19}N_3O_4S$), in 10 mL of water is between 8.0 and 10.0.

Purity (1) Clarity and color of solution—Dissolve an amount of Ampicillin Sodium and Sulbactam Sodium for Injection, equivalent to 1.0 g (potency) of ampicillin ($C_{16}H_{19}N_3O_4S$), in 10 mL of water: the solution is clear. Determine the absorption of this solution as directed under Ultraviolet-visible Spectrophotometry <2.24>: the absorbance at 425 nm is not more than 0.10.

(2) Total penicilloic acid—Weigh accurately about 25 mg of Ampicillin Sodium and Sulbactam Sodium for Injection, place in a glass-stoppered flask, dissolve in 25 mL of 0.02 mol/L phosphate buffer solution (pH 3.0), add exactly 5 mL of 0.005 mol/L iodine VS, stopper the flask, allow to stand for 5 minutes, and titrate <2.50> with 0.005 mol/L sodium thiosulfate VS (indicator: 1.0 mL of starch TS). Perform a blank determination in the same manner, and make any necessary correction: the amount of total penicilloic acid (as $C_{16}H_{21}N_3O_5S$: 367.42) is not more than 3.0%.

$$\begin{aligned} \text{Each mL of 0.005 mol/L sodium thiosulfate VS} \\ = 0.2064 \text{ mg of } C_{16}H_{21}N_3O_5S \end{aligned}$$

Water <2.48> Not more than 2.0% (0.5 g, volumetric titration, direct titration).

Bacterial endotoxins <4.01> Less than 0.10 EU/mg (potency).

Uniformity of dosage units <6.02> Perform the test according to the following method: it meets the requirement of the Content uniformity test (T : 105.0%).

Dissolve 1 Ampicillin Sodium and Sulbactam Sodium for Injection in the mobile phase to make exactly V mL so that each mL contains 5 mg (potency) of ampicillin ($C_{16}H_{19}N_3O_4S$). Pipet 5 mL of this solution, add exactly 5 mL of the internal standard solution, then add the mobile phase to make 50 mL, and use this solution as the sample solution. Then, proceed as directed in the Assay.

$$\begin{aligned} \text{Amount [mg (potency)] of ampicillin } (C_{16}H_{19}N_3O_4S) \\ = M_{S1} \times Q_{Ta}/Q_{Sa} \times V/10 \end{aligned}$$

$$\begin{aligned} \text{Amount [mg (potency)] of sulbactam } (C_8H_{11}NO_5S) \\ = M_{S2} \times Q_{Tb}/Q_{Sb} \times V/10 \end{aligned}$$

M_{S1} : Amount [mg (potency)] of Ampicillin RS taken
 M_{S2} : Amount [mg (potency)] of Sulbactam RS taken

Internal standard solution—A solution of parahydroxybenzoic acid in the mobile phase (1 in 1000).

Foreign insoluble matter <6.06> Perform the test according to Method 2: it meets the requirement.

Insoluble particulate matter <6.07> It meets the requirement.

Sterility <4.06> Perform the test according to the Membrane filtration method: it meets the requirement.

Assay Weigh accurately the mass of the contents of not less than 10 containers of Ampicillin Sodium and Sulbactam Sodium for Injection. Weigh accurately an amount of a portion of the contents, equivalent to about 0.25 g (potency) of ampicillin ($C_{16}H_{19}N_3O_4S$), and dissolve in the mobile phase to make exactly 50 mL. Pipet 5 mL of this solution, add exactly 5 mL of the internal standard solution, add the mobile phase to make 50 mL, and use this solution as the sample solution. Separately, weigh accurately an amount of Ampicillin RS, equivalent to about 50 mg (potency), and an amount of Sulbactam RS, equivalent to about 25 mg (potency), dissolve in the mobile phase, add exactly 10 mL of the internal standard solution, add the mobile phase to make 100 mL, and use this solution as the standard solution. Perform the test with 10 μ L each of the sample solution and standard solution as directed under Liquid Chromatography <2.01> according to the following conditions, and calculate the ratios, Q_{Ta} and Q_{Tb} , of the peak areas of ampicillin and sulbactam to that of the internal standard obtained from the sample solution, and the ratios, Q_{Sa} and Q_{Sb} , of the peak areas of ampicillin and sulbactam to that of the internal standard from the standard solution.

$$\begin{aligned} \text{Amount [mg (potency)] of ampicillin } (C_{16}H_{19}N_3O_4S) \\ = M_{S1} \times Q_{Ta}/Q_{Sa} \times 5 \end{aligned}$$

$$\begin{aligned} \text{Amount [mg (potency)] of sulbactam } (C_8H_{11}NO_5S) \\ = M_{S2} \times Q_{Tb}/Q_{Sb} \times 5 \end{aligned}$$

M_{S1} : Amount [mg (potency)] of Ampicillin RS taken
 M_{S2} : Amount [mg (potency)] of Sulbactam RS taken

Internal standard solution—A solution of parahydroxybenzoic acid in the mobile phase (1 in 1000).

Operating conditions—

Detector: An ultraviolet absorption photometer (wavelength: 215 nm).

Column: A stainless steel column 4.6 mm in inside diameter and 15 cm in length, packed with octadecylsilanized silica gel for liquid chromatography (10 μ m in particle diameter).

Column temperature: A constant temperature of about 35°C.

Mobile phase: A mixture of 0.02 mol/L phosphate buffer (pH 3.0) and acetonitrile for liquid chromatography (23:2).

Flow rate: Adjust so that the retention time of the internal standard is about 9 minutes.

System suitability—

System performance: When the procedure is run with 10 μ L of the standard solution under the above operating conditions, sulbactam, the internal standard and ampicillin are eluted in this order, and either resolution between these peaks is not less than 2.0.

System repeatability: When the test is repeated 6 times with 10 μ L of the standard solution under the above operat-

ing conditions, the relative standard deviation of the peak area of sulbactam is not more than 1.0%.

Containers and storage—Hermetic containers. Plastic containers for aqueous injections may be used.

Ampiroxicam

アンピロキシカム

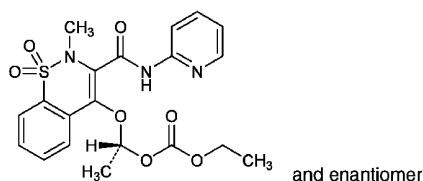

$C_{20}H_{21}N_3O_7S$: 447.46

Ethyl (1*RS*)-1-[(2-methyl-1,1-dioxido-3-[(pyridin-2-ylamino)carbonyl]-2*H*-1,2-benzothiazin-4-yl)oxy]ethyl carbonate [99464-64-9]

Ampiroxicam, when dried, contains not less than 99.0% and not more than 101.0% of ampiroxicam ($C_{20}H_{21}N_3O_7S$).

Description Ampiroxicam occurs as a white to yellowish white crystalline powder.

It is freely soluble in acetic acid (100), soluble in acetonitrile, very slightly soluble in ethanol (99.5), and practically insoluble in water.

A solution of Ampiroxicam in acetonitrile (1 in 20) shows no optical rotation.

It shows crystal polymorphism.

Identification (1) Determine the absorption spectrum of a solution of Ampiroxicam in 0.01 mol/L hydrochloric acid-methanol TS (1 in 100,000) as directed under Ultraviolet-visible Spectrophotometry <2.24>, and compare the spectrum with the Reference Spectrum: both spectra exhibit similar intensities of absorption at the same wavelengths.

(2) Determine the infrared absorption spectrum of Ampiroxicam as directed in the potassium bromide disk method under Infrared Spectrophotometry <2.25>, and compare the spectrum with the Reference Spectrum: both spectra exhibit similar intensities of absorption at the same wave numbers.

Purity (1) Heavy metals <1.07>—Proceed with 1.0 g of Ampiroxicam according to Method 2, and perform the test. Prepare the control solution with 2.0 mL of Standard Lead solution (not more than 20 ppm).

(2) Related substances—Dissolve 20 mg of Ampiroxicam in 50 mL of acetonitrile, and use this solution as the sample solution. Pipet 1 mL of the sample solution, add acetonitrile to make exactly 200 mL, and use this solution as the standard solution. Perform the test with exactly 10 μ L each of the sample solution and standard solution as directed under Liquid Chromatography <2.01> according to the following conditions, and determine each peak area by the automatic integration method: the area of the peak, having a relative retention time of about 0.17 to ampiroxicam, obtained from the sample solution is not larger than 1/2 times the peak area of ampiroxicam from the standard solution, the area of the peak other than ampiroxicam and the peak mentioned above from the sample solution is not larger than 2/5 times the peak area of ampiroxicam from the standard solution, and the total area of the peaks other than ampiroxicam from the sample solution is not larger than the peak area of ampiro-

xicam from the standard solution. For the area of the peaks, having the relative retention time of about 0.17 and about 0.46 to ampiroxicam, multiply the correction factor, 0.37 and 0.60, respectively.

Operating conditions—

Detector: An ultraviolet absorption photometer (wavelength: 254 nm).

Column: A stainless steel column 3.9 mm in inside diameter and 15 cm in length, packed with octadecylsilanized silica gel for liquid chromatography (4 μ m in particle diameter).

Column temperature: A constant temperature of about 25°C.

Mobile phase: A mixture of diluted acetic acid (100) (3 in 500), methanol and acetonitrile (5:3:2).

Flow rate: Adjust so that the retention time of ampiroxicam is about 9 minutes.

Time span of measurement: About 2 times as long as the retention time of ampiroxicam, beginning after the solvent peak.

System suitability—

Test for required detectability: Pipet 5 mL of the standard solution, add acetonitrile to make exactly 50 mL. Confirm that the peak area of ampiroxicam obtained with 10 μ L of this solution is equivalent to 7 to 13% of that with 10 μ L of the standard solution.

System performance: When the procedure is run with 10 μ L of the standard solution under the above operating conditions, the number of theoretical plates and the symmetry factor of the peak of ampiroxicam are not less than 3000 and not more than 2.0, respectively.

System repeatability: When the test is repeated 6 times with 10 μ L of the standard solution under the above operating conditions, the relative standard deviation of the peak area of ampiroxicam is not more than 5%.

Loss on drying <2.41> Not more than 0.5% (1 g, 105°C, 3 hours).

Residue on ignition <2.44> Not more than 0.2% (1 g).

Assay Weigh accurately about 0.22 g of Ampiroxicam, previously dried, dissolve in 50 mL of acetic acid (100), and titrate <2.50> with 0.1 mol/L perchloric acid VS (potentiometric titration). Perform a blank determination in the same manner, and make any necessary correction.

Each mL of 0.1 mol/L perchloric acid VS
= 44.75 mg of $C_{20}H_{21}N_3O_7S$

Containers and storage Containers—Tight containers.

Storage—Light-resistant.

Ampiroxicam Capsules

アンピロキシカムカプセル

Ampiroxicam Capsules contain not less than 95.0% and not more than 105.0% of the labeled amount of ampiroxicam ($C_{20}H_{21}N_3O_7S$: 447.46).

Method of Preparation Prepare as directed under Capsules, with Ampiroxicam.

Identification Take out the contents of Ampiroxicam Capsules, to a quantity of the contents, equivalent to 10 mg of Ampiroxicam, add 100 mL of 0.01 mol/L hydrochloric acid-methanol TS, shake well, and centrifuge. To 5 mL of the supernatant liquid add 0.01 mol/L hydrochloric acid-methanol TS to make 50 mL. Determine the absorption spectrum of

this solution as directed under Ultraviolet-visible Spectrophotometry <2.24>: it exhibits a maximum between 318 nm and 322 nm.

Uniformity of dosage units <6.02> Perform the test according to the following method: it meets the requirement of the Content uniformity test.

Take out the contents of 1 capsule of Ampiroxicam Capsules, add acetonitrile to make exactly V mL so that each mL contains about 0.27 mg of ampiroxicam ($C_{20}H_{21}N_3O_7S$). Stir for 30 minutes, then centrifuge, and use the supernatant liquid as the sample solution. Then, proceed as directed in the Assay.

$$\begin{aligned} \text{Amount (mg) of ampiroxicam (C}_{20}\text{H}_{21}\text{N}_3\text{O}_7\text{S)} \\ = M_S \times A_T/A_S \times V/100 \end{aligned}$$

M_S : Amount (mg) of ampiroxicam for assay taken

Dissolution <6.10> When the test is performed at 50 revolutions per minute according to the Paddle method using the sinker, using 900 mL of 1st fluid for dissolution test as the dissolution medium, the dissolution rate in 30 minutes of Ampiroxicam Capsules is not less than 70%.

Start the test with 1 capsule of Ampiroxicam Capsules, withdraw not less than 20 mL of the medium at the specified minute after starting the test, and filter through a membrane filter with a pore size not exceeding 0.45 μm . Discard not less than 10 mL of the first filtrate, pipet V mL of the subsequent filtrate, add the dissolution medium to make exactly V' mL so that each mL contains about 15 μg of ampiroxicam ($C_{20}H_{21}N_3O_7S$), and use this solution as the sample solution. Separately, weigh accurately about 30 mg of ampiroxicam for assay, previously dried at 105°C for 3 hours, dissolve in 5 mL of acetonitrile, and add the dissolution medium to make exactly 100 mL. Pipet 5 mL of this solution, add the dissolution medium to make exactly 100 mL, and use this solution as the standard solution. Determine the absorbances, A_T and A_S , at 320 nm of the sample solution and standard solution as directed under Ultraviolet-visible Spectrophotometry <2.24>, using the dissolution medium as the blank.

Dissolution rate (%) with respect to the labeled amount of ampiroxicam ($C_{20}H_{21}N_3O_7S$)

$$= M_S \times A_T/A_S \times V'/V \times 1/C \times 45$$

M_S : Amount (mg) of ampiroxicam for assay taken

C : Labeled amount (mg) of ampiroxicam ($C_{20}H_{21}N_3O_7S$) in 1 capsule

Assay Take out the contents of not less than 20 Ampiroxicam Capsules, weigh accurately the mass of the contents, and powder if necessary. Weigh accurately a portion of the powder, equivalent to about 13.5 mg of ampiroxicam ($C_{20}H_{21}N_3O_7S$), and add acetonitrile to make exactly 50 mL. Stir for 30 minutes, centrifuge, and use the supernatant liquid as the sample solution. Separately, weigh accurately about 27 mg of ampiroxicam for assay, previously dried at 105°C for 3 hours, dissolve in acetonitrile to make exactly 100 mL, and use this solution as the standard solution. Perform the test with exactly 10 μL each of the sample solution and standard solution as directed under Liquid Chromatography <2.01> according to the following condition, and determine the peak areas, A_T and A_S , of ampiroxicam in each solution.

$$\begin{aligned} \text{Amount (mg) of ampiroxicam (C}_{20}\text{H}_{21}\text{N}_3\text{O}_7\text{S)} \\ = M_S \times A_T/A_S \times 1/2 \end{aligned}$$

M_S : Amount (mg) of ampiroxicam for assay taken

Operating conditions—

Detector: An ultraviolet absorption photometer (wavelength: 254 nm).

Column: A stainless steel column 3.9 mm in inside diameter and 15 cm in length, packed with octadecylsilanized silica gel for liquid chromatography (4 μm in particle diameter).

Column temperature: A constant temperature of about 25°C.

Mobile phase: A mixture of diluted acetic acid (100) (3 in 500), methanol, and acetonitrile (5:3:2).

Flow rate: Adjust so that the retention time of ampiroxicam is about 9 minutes.

System suitability—

System performance: When the procedure is run with 10 μL of the standard solution under the above operating conditions, the number of theoretical plates and the symmetry factor of the peak of ampiroxicam are not less than 4000 and not more than 2.0, respectively.

System repeatability: When the test is repeated 6 times with 10 μL of the standard solution under the above operating conditions, the relative standard deviation of the peak area of ampiroxicam is not more than 1.0%.

Containers and storage Containers—Well-closed containers.

Amyl Nitrite

亜硝酸アミル

$C_5H_{11}NO_2$: 117.15

Amyl Nitrite is the nitrous acid ester of 3-methylbutanol-1 and contains a small quantity of 2-methylbutanol-1 and the nitrous acid esters of other homologues.

It contains not less than 90.0% of amyl nitrite ($C_5H_{11}NO_2$).

Description Amyl Nitrite is a clear, light yellow-liquid, and has a characteristic, fruity odor.

It is miscible with ethanol (95), and with diethyl ether.

It is practically insoluble in water.

It is affected by light and by heat.

It is volatile at ordinary temperature and flammable even at a low temperature.

Boiling point: about 97°C

Identification Determine the infrared spectrum of Amyl Nitrite as directed in the liquid film method under Infrared Spectrophotometry <2.25>, and compare the spectrum with the Reference Spectrum: both spectra exhibit similar intensities of absorption at the same wave numbers.

Specific gravity <2.56> d_{20}^{20} : 0.871 – 0.880

Purity (1) Acidity—To 5 mL of Amyl Nitrite add a mixture of 1.0 mL of 1 mol/L sodium hydroxide VS, 10 mL of water and 1 drop of phenolphthalein TS, shake, and allow to stand for 1 minute: the light red color of the water layer does not disappear.

(2) Water—Allow 2.0 mL of Amyl Nitrite to stand in ice water: no turbidity is produced.

(3) Aldehyde—To 3 mL of a mixture of equal volumes of silver nitrate TS and aldehyde free-ethanol add ammonia TS dropwise until the precipitate first formed is redissolved. Add 1.0 mL of Amyl Nitrite, and warm between 60°C and 70°C for 1 minute: a brown to black color is not produced.

(4) Residue on evaporation—Evaporate 10.0 mL of

Amyl Nitrite on a water bath in a draft chamber, carefully protecting from flame, and dry the residue at 105°C for 1 hour: the mass of the residue is not more than 1.0 mg.

Assay Weigh accurately a volumetric flask containing 10 mL of ethanol (95), add about 0.5 g of Amyl Nitrite, and weigh accurately again. Add exactly 25 mL of 0.1 mol/L silver nitrate VS, then add 15 mL of potassium chlorate solution (1 in 20) and 10 mL of dilute nitric acid, stopper the flask immediately, and shake it vigorously for 5 minutes. Dilute with water to make exactly 100 mL, shake, and filter through dry filter paper. Discard the first 20 mL of the filtrate, measure exactly 50 mL of the subsequent filtrate, and titrate <2.50> the excess silver nitrate with 0.1 mol/L ammonium thiocyanate VS (indicator: 2 mL of ammonium iron (III) sulfate TS). Perform a blank determination in the same manner.

Each mL of 0.1 mol/L silver nitrate VS
= 35.15 mg of C₅H₁₁NO₂

Containers and storage Containers—Hermetic containers not exceeding 10-ml capacity.

Storage—Light-resistant, in a cold place, and remote from fire.

Dental Antiformin

Dental Sodium Hypochlorite Solution

歯科用アンチホルミン

Dental Antiformin contains not less than 3.0 w/v% and not more than 6.0 w/v% of sodium hypochlorite (NaClO: 74.44).

Description Dental Antiformin is a slightly light yellow-green, clear liquid. It has a slight odor of chlorine.

It gradually changes by light.

Identification (1) Dental Antiformin changes red litmus paper to blue, and then decolorizes it.

(2) To Dental Antiformin add dilute hydrochloric acid: it evolves the odor of chlorine, and the gas changes potassium iodide starch paper moistened with water to blue.

(3) Dental Antiformin responds to Qualitative Tests <1.09> (1) for sodium salt.

Assay Measure exactly 3 mL of Dental Antiformin in a glass-stoppered flask, add 50 mL of water, 2 g of potassium iodide and 10 mL of acetic acid (31), and titrate <2.50> the liberated iodine with 0.1 mol/L sodium thiosulfate VS (indicator: 3 mL of starch TS).

Each mL of 0.1 mol/L sodium thiosulfate VS
= 3.722 mg of NaClO

Containers and storage Containers—Tight containers.

Storage—Light-resistant, and not exceeding 10°C.

Antipyrine

Phenazone

アンチピリン

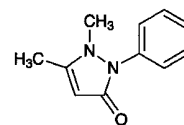

C₁₁H₁₂N₂O: 188.23

1,5-Dimethyl-2-phenyl-1,2-dihydro-3H-pyrazol-3-one
[60-80-0]

Antipyrine, when dried, contains not less than 99.0% of antipyrine (C₁₁H₁₂N₂O).

Description Antipyrine occurs as colorless or white crystals, or a white, crystalline powder. It is odorless, and has a slightly bitter taste.

It is very soluble in water, freely soluble in ethanol (95), and sparingly soluble in diethyl ether.

A solution of Antipyrine (1 in 10) is neutral.

Identification (1) To 5 mL of a solution of Antipyrine (1 in 100) add 2 drops of sodium nitrite TS and 1 mL of dilute sulfuric acid: a deep green color develops.

(2) To 2 mL of a solution of Antipyrine (1 in 100) add 4 drops of dilute iron (III) chloride TS: a yellow-red color develops. Then add 10 drops of dilute sulfuric acid: the color changes to light yellow.

(3) To 5 mL of a solution of Antipyrine (1 in 100) add 2 to 3 drops of tannic acid TS: a white precipitate is produced.

(4) To 0.1 g of Antipyrine add 0.1 g of vanillin, 5 mL of water and 2 mL of sulfuric acid, boil the mixture, and cool: a yellow-red precipitate is produced.

Melting point <2.60> 111 – 113°C

Purity (1) Chloride <1.03>—Perform the test with 1.0 g of Antipyrine. Prepare the control solution with 0.40 mL of 0.01 mol/L hydrochloric acid VS (not more than 0.014%).

(2) Heavy metals <1.07>—Proceed with 1.0 g of Antipyrine according to Method 1, and perform the test. Prepare the control solution with 2.0 mL of Standard Lead Solution (not more than 20 ppm).

(3) Readily carbonizable substances <1.15>—Perform the test with 0.5 g of Antipyrine: the solution remains colorless.

Loss on drying <2.41> Not more than 0.5% (1 g, silica gel, 4 hours).

Residue on ignition <2.44> Not more than 0.1% (1 g).

Assay Dissolve about 0.2 g of Antipyrine, previously dried and accurately weighed, in 20 mL of sodium acetate TS, add exactly 30 mL of 0.05 mol/L iodine VS, and allow to stand for 20 minutes with occasional shaking. Dissolve the precipitate in 10 mL of chloroform, and titrate <2.50> the excess iodine with 0.1 mol/L sodium thiosulfate VS (indicator: 3 mL of starch TS). Perform a blank determination in the same manner.

Each mL of 0.05 mol/L iodine VS
= 9.412 mg of C₁₁H₁₂N₂O

Containers and storage Containers—Well-closed containers.

Aprindine Hydrochloride

アプリンジン塩酸塩

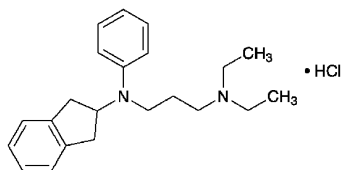

$C_{22}H_{30}N_2 \cdot HCl$: 358.95

N-(2,3-Dihydro-1*H*-inden-2-yl)-*N*',*N*'-diethyl-*N*-phenylpropane-1,3-diamine monohydrochloride
[33237-74-0]

Aprindine Hydrochloride, when dried, contains not less than 98.5% and not more than 101.0% of aprindine hydrochloride ($C_{22}H_{30}N_2 \cdot HCl$).

Description Aprindine Hydrochloride occurs as a white to pale yellow-white crystalline powder. It has a bitter taste, numbing the tongue.

It is very soluble in water, in methanol and in acetic acid (100), and freely soluble in ethanol (99.5).

It gradually turns brown on exposure to light.

Identification (1) Dissolve 10 mg of Aprindine Hydrochloride in a solution of hydrochloric acid in diluted ethanol (1 in 2) (1 in 125) to make 50 mL. Determine the absorption spectrum of this solution as directed under Ultraviolet-visible Spectrophotometry <2.24>, and compare the spectrum with the Reference Spectrum: both spectra exhibit similar intensities of absorption at the same wavelengths.

(2) Determine the infrared absorption spectrum of Aprindine Hydrochloride as directed in the potassium chloride disk method under Infrared Spectrophotometry <2.25>, and compare the spectrum with the Reference Spectrum: both spectra exhibit similar intensities of absorption at the same wave numbers.

(3) To 5 mL of a solution of Aprindine Hydrochloride (1 in 50) add 1 mL of dilute nitric acid: this solution responds to Qualitative Tests <1.09> for chloride.

pH <2.54> Dissolve 1.0 g of Aprindine Hydrochloride in 50 mL of water: the pH of the solution is between 6.4 and 7.0.

Melting point <2.60> 127 – 131°C

Purity (1) Clarity and color of solution—Dissolve 1.0 g of Aprindine Hydrochloride in 10 mL of methanol: the solution is clear, and its absorbance at 420 nm determined as directed under Ultraviolet-visible Spectrophotometry <2.24> is not more than 0.10.

(2) Heavy metals <1.07>—Proceed with 1.0 g of Aprindine Hydrochloride according to Method 2, and perform the test. Prepare the control solution with 1.0 mL of Standard Lead Solution (not more than 10 ppm).

(3) Related substances—Dissolve 25 mg of Aprindine Hydrochloride in 10 mL of the mobile phase, and use this solution as the sample solution. Pipet 1 mL of the sample solution, add the mobile phase to make exactly 100 mL, and use this solution as the standard solution. Perform the test with exactly 10 μ L each of the sample solution and standard solution as directed under Liquid Chromatography <2.01> according to the following conditions. Determine each peak area of both solutions by the automatic integration method: the area of the peak other than aprindine obtained from the sample solution is not larger than 1/10 times the peak area

of aprindine from the standard solution.

Operating conditions—

Detector: An ultraviolet absorption photometer (wavelength: 254 nm).

Column: A stainless steel column 4.6 mm in inside diameter and 15 cm in length, packed with octadecylsilanized silica gel for liquid chromatography (5 μ m in particle diameter).

Column temperature: A constant temperature of about 40°C.

Mobile phase: Dissolve 3.40 g of potassium dihydrogen phosphate in 500 mL of water, and adjust the pH to 3.0 with hydrochloric acid. To 500 mL of this solution add 500 mL of acetonitrile.

Flow rate: Adjust so that the retention time of aprindine is about 6 minutes.

Time span of measurement: About 4 times as long as the retention time of aprindine.

System suitability—

Test for required detectability: Pipet 1 mL of the standard solution, and add the mobile phase to make exactly 10 mL. Confirm that the peak area of aprindine obtained with 10 μ L of this solution is equivalent to 7 to 13% of that with 10 μ L of the standard solution.

System performance: When the procedure is run with 10 μ L of the standard solution under the above operating conditions, the number of theoretical plates and the symmetry factor of the peak of aprindine are not less than 3000 and not more than 2.0, respectively.

System repeatability: When the test is repeated 6 times with 10 μ L of the standard solution under the above operating conditions, the relative standard deviation of the peak area of aprindine is not more than 1.5%.

Loss on drying <2.41> Not more than 0.5% (1 g, in vacuum, 60°C, 4 hours).

Residue on ignition <2.44> Not more than 0.1% (1 g).

Assay Weigh accurately about 0.5 g of Aprindine Hydrochloride, previously dried, dissolve in 80 mL of acetic acid (100), and titrate <2.50> with 0.1 mol/L perchloric acid VS (potentiometric titration). Perform a blank determination in the same manner, and make any necessary correction.

Each mL of 0.1 mol/L perchloric acid VS
= 35.90 mg of $C_{22}H_{30}N_2 \cdot HCl$

Containers and storage Containers—Well-closed containers.

Storage—Light-resistant.

Aprindine Hydrochloride Capsules

アプリンジン塩酸塩カプセル

Aprindine Hydrochloride Capsules contain not less than 95.0% and not more than 105.0% of the labeled amount of aprindine hydrochloride ($C_{22}H_{30}N_2 \cdot HCl$: 358.95).

Method of preparation Prepare as directed under Capsules, with Aprindine Hydrochloride.

Identification Determine the absorption spectrum of the sample solution obtained in the Assay as directed under Ultraviolet-visible Spectrophotometry <2.24>, it exhibits maxima between 264 nm and 268 nm, and between 271 nm and 275 nm.

Uniformity of dosage units <6.02> Perform the test according to the following method: it meets the requirement of the Content uniformity test.

Take out the contents of 1 capsule of Aprindine Hydrochloride Capsules, add 30 mL of a solution of hydrochloric acid in diluted ethanol (1 in 2) (1 in 125), shake vigorously for 20 minutes, add a solution of hydrochloric acid in diluted ethanol (1 in 2) (1 in 125) to make exactly V mL so that each mL contains about 0.2 mg of aprindine hydrochloride ($C_{22}H_{30}N_2 \cdot HCl$), and filter. Discard the first 5 mL of the filtrate, and use the subsequent filtrate as the sample solution. Proceed as directed in the Assay.

$$\text{Amount (mg) of aprindine hydrochloride (C}_{22}\text{H}_{30}\text{N}_2\text{.HCl)} \\ = M_S \times A_T/A_S \times V/250$$

M_S : Amount (mg) of aprindine hydrochloride for assay taken

Dissolution <6.10> When the test is performed at 50 revolutions per minute according to the Paddle method using the sinker, using 900 mL of water as the dissolution medium, the dissolution rate in 15 minutes of Aprindine Hydrochloride Capsules is not less than 80%.

Start the test with 1 capsule of Aprindine Hydrochloride Capsules, withdraw not less than 20 mL of the medium at the specified minute after starting the test, and filter through a membrane filter with a pore size not exceeding 0.45 μm . Discard not less than 10 mL of the first filtrate, pipet V mL of the subsequent filtrate, add water to make exactly V' mL so that each mL contains about 11 μg of aprindine hydrochloride ($C_{22}H_{30}N_2 \cdot HCl$), and use this solution as the sample solution. Separately, weigh accurately about 28 mg of aprindine hydrochloride for assay, previously dried in vacuum at 60°C for 4 hours, and dissolve in water to make exactly 100 mL. Pipet 2 mL of this solution, add water to make exactly 50 mL, and use this solution as the standard solution. Perform the test with exactly 20 μL each of the sample solution and standard solution as directed under Liquid Chromatography <2.01> according to the following conditions, and determine the peak areas, A_T and A_S , of aprindine in each solution.

$$\text{Dissolution rate (\%)} \text{ with respect to the labeled amount} \\ \text{of aprindine hydrochloride (C}_{22}\text{H}_{30}\text{N}_2\text{.HCl)} \\ = M_S \times A_T/A_S \times V'/V \times 1/C \times 36$$

M_S : Amount (mg) of aprindine hydrochloride for assay taken

C : Labeled amount (mg) of aprindine hydrochloride ($C_{22}H_{30}N_2 \cdot HCl$) in 1 capsule

Operating conditions—

Detector: An ultraviolet absorption photometer (wavelength: 254 nm).

Column: A stainless steel column 4.6 mm in inside diameter and 15 cm in length, packed with octadecylsilanized silica gel for liquid chromatography (5 μm in particle diameter).

Column temperature: A constant temperature of about 40°C.

Mobile phase: Dissolve 3.40 g of potassium dihydrogen phosphate in 500 mL of water, and adjust the pH to 3.0 with hydrochloric acid. To 500 mL of this solution add 500 mL of acetonitrile.

Flow rate: Adjust so that the retention time of aprindine is about 6 minutes.

System suitability—

System performance: When the procedure is run with 20 μL of the standard solution under the above operating conditions, the number of theoretical plates and the symmetry

factor of the peak of aprindine are not less than 3000 and not more than 2.0, respectively.

System repeatability: When the test is repeated 6 times with 20 μL of the standard solution under the above operating conditions, the relative standard deviation of the peak area of aprindine is not more than 1.5%.

Assay Take out the contents of not less than 20 Aprindine Hydrochloride Capsules, weigh accurately the mass of the contents, and powder. Weigh accurately a portion of the powder, equivalent to about 0.1 g of aprindine hydrochloride ($C_{22}H_{30}N_2 \cdot HCl$), add 60 mL of a solution of hydrochloric acid in diluted ethanol (1 in 2) (1 in 125), shake vigorously for 20 minutes, and add a solution of hydrochloric acid in diluted ethanol (1 in 2) (1 in 125) to make exactly 100 mL. Pipet 10 mL of this solution, add a solution of hydrochloric acid in diluted ethanol (1 in 2) (1 in 125) to make exactly 50 mL, and filter, Discard the first 5 mL of the filtrate, and use the subsequent filtrate as the sample solution. Separately, weigh accurately about 50 mg of aprindine hydrochloride for assay, previously dried in vacuum at 60°C for 4 hours, and dissolve in a solution of hydrochloric acid in diluted ethanol (1 in 2) (1 in 125) to make exactly 50 mL. Pipet 10 mL of this solution, add a solution of hydrochloric acid in diluted ethanol (1 in 2) (1 in 125) to make exactly 50 mL, and use this solution as the standard solution. Determine the absorbances, A_T and A_S , of the sample solution and standard solution at 265 nm as directed under Ultraviolet-visible Spectrophotometry <2.24>.

$$\text{Amount (mg) of aprindine hydrochloride (C}_{22}\text{H}_{30}\text{N}_2\text{.HCl)} \\ = M_S \times A_T/A_S \times 2$$

M_S : Amount (mg) of aprindine hydrochloride for assay taken

Containers and storage Containers—Tight containers.

Storage—Light-resistant.

Arbekacin Sulfate

アルベカシン硫酸塩

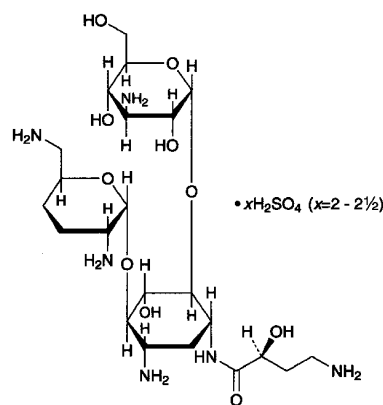

$C_{22}H_{44}N_6O_{10} \cdot xH_2SO_4$ ($x = 2 - 2\frac{1}{2}$)
3-Amino-3-deoxy- α -D-glucopyranosyl-(1 \rightarrow 6)-
[2,6-diamino-2,3,4,6-tetrahydroxy- α -D-erythro-
hexopyranosyl-(1 \rightarrow 4)]-1-N-[(2S)-4-amino-2-
hydroxybutanoyl]-2-deoxy-D-streptamine sulfate
[51025-85-5, Arbekacin]

Arbekacin Sulfate is the sulfate of a derivative of dibekacin.

It contains not less than 670 μg (potency) and not more than 750 μg (potency) per mg, calculated on the

dried basis. The potency of Arbekacin Sulfate is expressed as mass (potency) of arbekacin ($C_{22}H_{44}N_6O_{10}$: 552.62).

Description Arbekacin Sulfate occurs as a white powder.

It is very soluble in water, and practically insoluble in ethanol (99.5).

Identification (1) Dissolve 10 mg each of Arbekacin Sulfate and Arbekacin Sulfate RS in 1 mL of water, and use these solutions as the sample solution and standard solution. Perform the test with these solutions as directed under Thin-layer Chromatography <2.03>. Spot 2 μ L each of the sample solution and standard solution on a plate of silica gel for thin-layer chromatography. Develop the plate with a mixture of ammonia solution (28), methanol, chloroform and ethanol (95) (7:6:4:1) to a distance of about 10 cm, and air-dry the plate. Spray evenly 0.2% ninhydrin-water saturated 1-butanol TS on the plate, and heat the plate at 100°C for 10 minutes: the principal spot obtained from the sample solution and the spot from the standard solution are purple-brown in color and their R_f values are the same.

(2) A solution of Arbekacin Sulfate (1 in 50) responds to Qualitative Tests <1.09> (1) for sulfate.

Optical rotation <2.49> $[\alpha]_D^{20}$: +69 – +79° (0.25 g after drying, water, 25 mL, 100 mm).

pH <2.54> The pH of a solution obtained by dissolving 0.75 g of Arbekacin Sulfate in 10 mL of water is between 6.0 and 8.0.

Purity (1) Clarity and color of solution—A solution obtained by dissolving 1.0 g of Arbekacin Sulfate in 5 mL of water is clear and colorless.

(2) Heavy metals <1.07>—Proceed with 2.0 g of Arbekacin Sulfate according to Method 1, and perform the test. Prepare the control solution with 2.0 mL of Standard Lead Solution (not more than 10 ppm).

(3) Dibekacin—Weigh accurately about 20 mg of Arbekacin Sulfate, add exactly 10 mL of the internal standard solution to dissolve, add water to make 20 mL, and use this solution as the sample solution. Separately, weigh accurately an amount of Dibekacin Sulfate RS, equivalent to about 10 mg (potency), and dissolve in water to make exactly 50 mL. Pipet 5 mL of this solution, add exactly 10 mL of the internal standard solution and water to make 20 mL, and use this solution as the standard solution. Perform the test with 5 μ L each of the sample solution and standard solution as directed under Liquid Chromatography <2.01> according to the following conditions, and calculate the ratios, Q_T and Q_S , of the peak area of dibekacin to that of the internal standard. Calculate the amount of dibekacin by the following equation: not more than 2.0%.

$$\begin{aligned} &\text{Amount (\%)} \text{ of dibekacin} \\ &= M_S/M_T \times Q_T/Q_S \times 1/10 \times 100 \end{aligned}$$

M_S : Amount [mg (potency)] of Dibekacin Sulfate RS taken

M_T : Amount (mg) of Arbekacin Sulfate taken

Internal standard solution—A solution of bekanamycin sulfate (1 in 2000).

Operating conditions—

Detector: Fluorometric detector (excitation wavelength: 340 nm, detection wavelength: 460 nm).

Column: A stainless steel column 4.6 mm in inside diameter and 15 cm in length, packed with octadecylsilanized silica gel for liquid chromatography (5 μ m in particle diameter).

Column temperature: A constant temperature of about

40°C.

Reaction coil: A column about 0.3 mm in inside diameter and about 3 m in length.

Reaction coil temperature: A constant temperature of about 50°C.

Mobile phase: Dissolve 8.70 g of sodium 1-pentane sulfonate and 8.52 g of anhydrous sodium sulfate in 980 mL of water, adjust the pH to 4.0 with acetic acid (100), and add water to make 1000 mL. To 230 mL of this solution add 20 mL of methanol.

Reagent: Dissolve 12.36 g of boric acid in 960 mL of water, add 10 mL of a solution of *o*-phthalaldehyde in ethanol (99.5) (1 in 25), adjust the pH to 10.5 with 8 mol/L potassium hydroxide TS, and add water to make 1000 mL. To this solution add 1 mL of 2-mercaptoethanol.

Reaction temperature: A constant temperature of about 50°C.

Flow rate of mobile phase: 0.5 mL per minute.

Flow rate of reagent: 1 mL per minute.

System suitability—

System performance: Dissolve 20 mg each of Arbekacin Sulfate, bekanamycin sulfate and dibekacin sulfate in 200 mL of water. When the procedure is run with 5 μ L of this solution under the above operating conditions, bekanamycin, arbekacin and dibekacin are eluted in this order, and the resolution between the peaks, bekanamycin and arbekacin is not less than 5 and arbekacin and dibekacin is not less than 1.5, respectively.

System repeatability: When the test is repeated 6 times with 5 μ L of the standard solution under the above operating conditions, the relative standard deviation of the ratio of the peak area of dibekacin to that of the internal standard is not more than 2.0%.

(4) Related substances—Dissolve 20 mg of Arbekacin Sulfate in 20 mL of water, and use this solution as the sample solution. Pipet 3 mL of the sample solution, add water to make exactly 250 mL, and use this solution as the standard solution. Perform the test with exactly 5 μ L each of the sample solution and standard solution as directed under Liquid Chromatography <2.01> according to the following conditions, and determine the area of each peak by the automatic integration method: the total area of the peaks other than arbekacin and dibekacin obtained from the sample solution is not larger than the peak area of arbekacin from the standard solution.

Operating conditions—

Detector, column, column temperature, reaction coil, reaction coil temperature, mobile phase, reagent, reaction temperature, flow rate of mobile phase, and flow rate of reagent: Proceed as directed in the operating conditions in the Purity (3).

Time span of measurement: About 1.5 times as long as the retention time of arbekacin.

System suitability—

System performance: Dissolve 10 mg each of Arbekacin Sulfate and dibekacin sulfate in 200 mL of water. When the procedure is run with 5 μ L of this solution under the above operating conditions, arbekacin and dibekacin are eluted in this order with the resolution between these peaks being not less than 1.5.

System repeatability: When the test is repeated 6 times with 5 μ L of the standard solution under the above operating conditions, the relative standard deviation of the peak area of arbekacin is not more than 5.0%.

Loss on drying <2.41> Not more than 5.0% (0.5 g, reduced pressure not exceeding 0.67 kPa, 60°C, 3 hours).

Assay Perform the test according to the Cylinder-plate method as directed under Microbial Assay for Antibiotics <4.02> according to the following conditions.

(i) Test organism—*Bacillus subtilis* ATCC 6633

(ii) Culture medium—Use the medium i in 1) under (1) Agar media for seed and base layer, having pH 7.8 – 8.0 after sterilization.

(iii) Standard solutions—Weigh accurately an amount of Arbekacin Sulfate RS, previously dried, equivalent to about 20 mg (potency), dissolve in diluted phosphate buffer solution (pH 6.0) (1 in 2) to make exactly 50 mL, and use this solution as the standard stock solution. Keep the standard stock solution at 5 to 15°C and use within 30 days. Take exactly a suitable amount of the standard stock solution before use, add 0.1 mol/L phosphate buffer solution (pH 8.0) to make solutions so that each mL contains 20 µg (potency) and 5 µg (potency), and use these solutions as the high concentration standard solution and low concentration standard solution, respectively.

(iv) Sample solutions—Weigh accurately an amount of Arbekacin Sulfate, equivalent to about 20 mg (potency), and dissolve in water to make exactly 50 mL. Take exactly a suitable amount of this solution, add 0.1 mol/L phosphate buffer solution (pH 8.0) to make solutions so that each mL contains 20 µg (potency) and 5 µg (potency), and use these solutions as the high concentration sample solution and low concentration sample solution, respectively.

Containers and storage Containers—Tight containers.

Arbekacin Sulfate Injection

アルベカシン硫酸塩注射液

Arbekacin Sulfate Injection is an aqueous injection.

It contains not less than 90.0% and not more than 110.0% of the labeled potency of arbekacin sulfate ($C_{22}H_{44}N_6O_{10}$: 552.62).

Method of preparation Prepare as directed under Injections, with Arbekacin Sulfate.

Description Arbekacin Sulfate Injection occurs as a clear and colorless liquid.

Identification To 0.2 mL of Arbekacin Sulfate Injection add 1 mL of water, and use this solution as the sample solution. Separately, dissolve 10 mg of Arbekacin Sulfate RS in 1 mL of water, and use this solution as the standard solution. Perform the test with these solutions as directed under Thin-layer Chromatography <2.03>. Spot 2 µL each of the sample solution and standard solution on a plate of silica gel for thin-layer chromatography. Develop with a mixture of ammonia solution (28), methanol, chloroform and ethanol (95) (7:6:4:1) to a distance of about 12 cm, and air-dry the plate. Spray evenly 0.2% ninhydrin-water saturated 1-butanol TS on the plate, and heat the plate at 80°C for 10 minutes: the principal spot obtained from the sample solution and the spot from the standard solution show a purple-brown color and the same *R_f* value.

Osmotic pressure ratio <2.47> 0.8 – 1.2 (for the preparation intended for intramuscular use).

pH <2.54> 6.0 – 8.0

Bacterial endotoxins <4.01> Less than 0.50 EU/mg (potency).

Extractable volume <6.05> It meets the requirement.

Foreign insoluble matter <6.06> Perform the test according to Method 1: it meets the requirement.

Insoluble particulate matter <6.07> It meets the requirement.

Sterility <4.06> Perform the test according to the Membrane filtration method: it meets the requirement.

Assay Perform the test according to the Cylinder-plate method as directed under Microbial Assay for Antibiotics <4.02> according to the following conditions.

(i) Test organism, Culture medium and Standard solutions: Proceed as directed in the Assay under Arbekacin Sulfate.

(ii) Sample solutions—Take exactly a volume of Arbekacin Sulfate Injection, equivalent to about 20 mg (potency), and add water to make exactly 50 mL. Take exactly a suitable amount of this solution, add 0.1 mol/L phosphate buffer solution (pH 8.0) to make solutions so that each mL contains 20 µg (potency) and 5 µg (potency), and use these solutions as the high concentration sample solution and low concentration sample solution, respectively.

Containers and storage Containers—Hermetic containers.

Argatroban Hydrate

アルガトロバン水和物

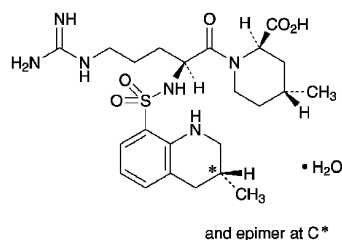

$C_{23}H_{36}N_6O_5S \cdot H_2O$: 526.65

(2*R*,4*R*)-4-Methyl-1-((2*S*)-2-[[[(3*R*)-3-methyl-1,2,3,4-tetrahydroquinolin-8-yl]sulfonyl]amino-5-guanidinopentanoyl)piperidine-2-carboxylic acid monohydrate
[141396-28-3]

Argatroban Hydrate contains not less than 98.5% and not more than 101.0% of argatroban ($C_{23}H_{36}N_6O_5S$: 508.63), calculated on the anhydrous basis.

Description Argatroban Hydrate occurs as white, crystals or crystalline powder. It has a bitter taste.

It is freely soluble in acetic acid (100), sparingly soluble in methanol, slightly soluble in ethanol (99.5), and very slightly soluble in water.

It is gradually decomposed on exposure to light.

Identification (1) Determine the absorption spectrum of a solution of Argatroban Hydrate in ethanol (99.5) (1 in 20,000) as directed under Ultraviolet-visible Spectrophotometry <2.24>, and compare the spectrum with the Reference Spectrum: both spectra exhibit similar intensities of absorption at the same wavelengths.

(2) Determine the infrared absorption spectrum of Argatroban Hydrate as directed in the potassium bromide disk method under Infrared Spectrophotometry <2.25>, and compare the spectrum with the Reference Spectrum: both spectra

exhibit similar intensities of absorption at the same wave numbers.

Optical rotation <2.49> $[\alpha]_D^{20}$: +175 – +185° (0.2 g calculated on the anhydrous basis, methanol, 25 mL, 100 mm).

Purity (1) Heavy metals <1.07>—Proceed with 2.0 g of Argatroban Hydrate according to Method 2, and perform the test. Prepare the control solution with 2.0 mL of Standard Lead Solution (not more than 10 ppm).

(2) Arsenic <1.11>—Incinerate 2.0 g of Argatroban Hydrate according to Method 4. After cooling, add 10 mL of dilute hydrochloric acid to the residue, dissolve by warming on a water bath, and perform the test using this solution as the test solution. Add 10 mL of a solution of magnesium nitrate hexahydrate in ethanol (95) (1 in 10), then add 1.5 mL of hydrogen peroxide (30), and fire to burn (not more than 1 ppm).

(3) Related substance 1—Dissolve 50 mg of Argatroban Hydrate in 40 mL of methanol, add water to make 100 mL, and use this solution as the sample solution. Perform the test with 10 μ L of the sample solution as directed under Liquid Chromatography <2.01> according to the following conditions. Determine each peak area from the sample solution by the automatic integration method, and calculate the amount of them by the area percentage method: the amount of each peak other than argatroban is not more than 0.1%.

Operating conditions—

Detector: An ultraviolet absorption photometer (wavelength: 254 nm).

Column: A stainless steel column 4.6 mm in inside diameter and 25 cm in length, packed with octadecylsilanized silica gel for liquid chromatography (5 μ m in particle diameter).

Column temperature: A constant temperature of about 45°C.

Mobile phase A: To 2.5 mL of acetic acid (100) add water to make 1000 mL, and adjust the pH to 5.0 with ammonia TS. To 500 mL of this solution add 500 mL of methanol.

Mobile phase B: To 2.5 mL of acetic acid (100) add water to make 1000 mL, and adjust the pH to 5.0 with ammonia TS. To 200 mL of this solution add 800 mL of methanol.

Flowing of mobile phase: Control the gradient by mixing the mobile phases A and B as directed in the following table.

Time after injection of sample (min)	Mobile phase A (vol%)	Mobile phase B (vol%)
0 – 5	100	0
5 – 35	100 → 5	0 → 95

Flow rate: About 1.0 mL per minute.

Time span of measurement: About 1.5 times as long as the retention time of argatroban, beginning after the solvent peak.

System suitability—

Test for required detectability: To 1 mL of the sample solution add the mobile phase A to make 100 mL, and use this solution as the solution for system suitability test. Pipet 1 mL of the solution for system suitability test, and add the mobile phase A to make exactly 10 mL. Confirm that the peak area of argatroban obtained with 10 μ L of this solution is equivalent to 7 to 13% of that with 10 μ L of the solution for system suitability test.

System performance: Dissolve 5 mg of Argatroban Hydrate and 5 μ L of methyl benzoate in 40 mL of methanol, and add water to make 100 mL. To 5 mL of this solution add 40 mL of methanol and water to make 100 mL. When

the procedure is run with 10 μ L of this solution under the above operating conditions, methyl benzoate and argatroban are eluted in this order with the resolution between these peaks being not less than 3.

System repeatability: When the test is repeated 6 times with 10 μ L of the solution for system suitability test under the above operating conditions, the relative standard deviation of the peak area of argatroban is not more than 2.0%.

(4) Related substance 2—Dissolve 0.10 g of Argatroban Hydrate in 10 mL of methanol, and use this solution as the sample solution. Pipet 3 mL of the sample solution, and add methanol to make exactly 100 mL. Pipet 5 mL of this solution, add methanol to make exactly 50 mL, and use this solution as the standard solution. Perform the test with these solutions as directed under Thin-layer Chromatography <2.03>. Spot 10 μ L each of the sample solution and standard solution on a plate of silica gel with fluorescent indicator for thin-layer chromatography. Develop the plate with a mixture of methanol, ethyl acetate and water (10:10:1) to a distance of about 10 cm, and air-dry the plate. Examine under ultraviolet light (main wavelength: 254 nm): the number of spots other than the principal spot obtained from the sample solution is not more than 2, and they are not more intense than the spot from the standard solution.

Water <2.48> 2.5 – 4.5% (0.2 g, volumetric titration, direct titration).

Residue on ignition <2.44> Not more than 0.1% (1 g).

Isomer ratio Dissolve 50 mg of Argatroban Hydrate in 50 mL of methanol, add water to make 100 mL, and use this solution as the sample solution. Perform the test with 10 μ L of the sample solution as directed under Liquid Chromatography <2.01> according to the following conditions. Determine the areas of two adjacent peaks, A_a and A_b , having the retention times of about 40 minutes, where A_a is the peak area of shorter retention time and A_b is the peak area of longer retention time: $A_b/(A_a + A_b)$ is between 0.30 and 0.40.

Operating conditions—

Detector: An ultraviolet absorption photometer (wavelength: 254 nm).

Column: A stainless steel column 6.0 mm in inside diameter and 15 cm in length, packed with octadecylsilanized silica gel for liquid chromatography (5 μ m in particle diameter).

Column temperature: A constant temperature of about 40°C.

Mobile phase: To 500 mL of water add 500 mL of methanol, 13 mL of diluted 40% tetrabutylammonium hydroxide TS (1 in 4) and 0.68 mL of phosphoric acid, and adjust the pH to 6.8 with ammonia TS and diluted ammonia solution (28) (1 in 20).

Flow rate: Adjust so that the retention time of the peak having the shorter retention time of the two peaks of argatroban is about 40 minutes.

System suitability—

System performance: When the procedure is run with 10 μ L of the sample solution under the above operating conditions, the resolution between the two peaks is not less than 1.2.

System repeatability: When the test is repeated 6 times with 10 μ L of the sample solution under the above operating conditions, the relative standard deviation of the total area of the two separate peaks of argatroban is not more than 2.0%.

Assay Weigh accurately about 0.5 g of Argatroban Hydrate, dissolve in 20 mL of acetic acid for nonaqueous titration, add 40 mL of acetone for nonaqueous titration, and

titrate <2.50> with 0.1 mol/L perchloric acid VS (potentiometric titration). Perform a blank determination in the same manner, and make any necessary correction.

Each mL of 0.1 mol/L perchloric acid VS
= 50.86 mg of C₂₃H₃₆N₆O₅S

Containers and storage Containers—Tight containers.
Storage—Light-resistant.

L-Arginine

L-アルギニン

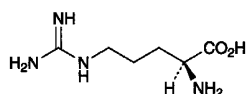

C₆H₁₄N₄O₂: 174.20

(2S)-2-Amino-5-guanidinopentanoic acid
[74-79-3]

L-Arginine, when dried, contains not less than 98.5% and not more than 101.0% of L-arginine (C₆H₁₄N₄O₂).

Description L-Arginine occurs as white, crystals or crystalline powder. It has a characteristic odor.

It is freely soluble in water and in formic acid, and practically insoluble in ethanol (99.5).

It dissolves in dilute hydrochloric acid.

It is hygroscopic.

Identification Determine the infrared absorption spectrum of previously dried L-Arginine as directed in the potassium bromide disk method under Infrared Spectrophotometry <2.25>, and compare the spectrum with the Reference Spectrum: both spectra exhibit similar intensities of absorption at the same wave numbers.

Optical rotation <2.49> [α]_D²⁰: +26.9 – +27.9° (after drying, 2 g, 6 mol/L hydrochloric acid TS, 25 mL, 100 mm).

pH <2.54> The pH of a solution prepared by dissolving 1.0 g of L-Arginine in 10 mL of water is between 10.5 and 12.0.

Purity (1) Clarity and color of solution—A solution obtained by dissolving 1.0 g of L-Arginine in 10 mL of water is clear and colorless.

(2) Chloride <1.03>—Perform the test with 0.5 g of L-Arginine. Prepare the control solution with 0.30 mL of 0.01 mol/L hydrochloric acid VS (not more than 0.021%).

(3) Sulfate <1.14>—Perform the test with 0.6 g of L-Arginine. Prepare the control solution with 0.35 mL of 0.005 mol/L sulfuric acid VS (not more than 0.028%).

(4) Ammonium <1.02>—Perform the test with 0.25 g of L-Arginine, using the distillation under reduced pressure. Prepare the control solution with 5.0 mL of Standard Ammonium Solution (not more than 0.02%).

(5) Heavy metals <1.07>—Dissolve 2.0 g of L-Arginine in 30 mL of water, add 1 drop of phenolphthalein TS, neutralize with dilute hydrochloric acid, add 2 mL of dilute acetic acid and water to make 50 mL, and perform the test. Prepare the control solution with 2.0 mL of Standard Lead Solution (not more than 10 ppm).

(6) Iron <1.10>—Prepare the test solution with 1.0 g of L-Arginine according to Method 1, and perform the test according to Method A. Prepare the control solution with 1.0 mL of Standard Iron Solution (not more than 10 ppm).

(7) Related substances—Dissolve 0.10 g of L-Arginine in 10 mL of water, and use this solution as the sample solution. Pipet 1 mL of the sample solution, and add water to make exactly 50 mL. Pipet 2 mL of this solution, add water to make exactly 20 mL, and use this solution as the standard solution. Perform the test with these solutions as directed under Thin-layer Chromatography <2.03>. Spot 5 μ L each of the sample solution and standard solution on a plate of silica gel for thin-layer chromatography. Develop the plate with a mixture of 2-propanol and ammonia solution (28) (7:3) to a distance of about 10 cm, and dry the plate at 80°C for 30 minutes. Spray evenly ninhydrin-butanol TS on the plate, and heat the plate at 80°C for 10 minutes: the spot other than the principal spot obtained from the sample solution is not more intense than the spot from the standard solution.

Loss on drying <2.41> Not more than 0.30% (1 g, 105°C, 3 hours).

Residue on ignition <2.44> Not more than 0.1% (1 g).

Assay Weigh accurately about 80 mg of L-Arginine, previously dried, dissolve in 3 mL of formic acid, add 50 mL of acetic acid (100), and titrate <2.50> with 0.1 mol/L perchloric acid VS (potentiometric titration). Perform a blank determination in the same manner, and make any necessary correction.

Each mL of 0.1 mol/L perchloric acid VS
= 8.710 mg of C₆H₁₄N₄O₂

Containers and storage Containers—Tight containers.

L-Arginine Hydrochloride

L-アルギニン塩酸塩

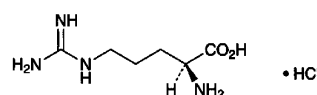

C₆H₁₄N₄O₂.HCl: 210.66

(2S)-2-Amino-5-guanidinopentanoic acid
monohydrochloride
[1119-34-2]

L-Arginine Hydrochloride, when dried, contains not less than 98.5% of L-arginine hydrochloride (C₆H₁₄N₄O₂.HCl).

Description L-Arginine Hydrochloride occurs as white, crystals or crystalline powder. It is odorless, and has a slight, characteristic taste.

It is freely soluble in water and in formic acid, and very slightly soluble in ethanol (95).

Identification (1) Determine the infrared absorption spectrum of L-Arginine Hydrochloride, previously dried, as directed in the potassium bromide disk method under Infrared Spectrophotometry <2.25>, and compare the spectrum with the Reference Spectrum: both spectra exhibit similar intensities of absorption at the same wave numbers.

(2) A solution of L-Arginine Hydrochloride (1 in 50) responds to the Qualitative Tests <1.09> for chloride.

Optical rotation <2.49> [α]_D²⁰: +21.5 – +23.5° (after drying, 2 g, 6 mol/L hydrochloric acid TS, 25 mL, 100 mm).

pH <2.54> Dissolve 1.0 g of L-Arginine Hydrochloride in 10 mL of water: the pH of this solution is between 4.7 and 6.2.

Purity (1) Clarity and color of solution—Dissolve 1.0 g of L-Arginine Hydrochloride in 10 mL of water: the solution is clear and colorless.

(2) Sulfate <1.14>—Perform the test with 0.6 g of L-Arginine Hydrochloride. Prepare the control solution with 0.35 mL of 0.005 mol/L sulfuric acid VS (not more than 0.028%).

(3) Ammonium <1.02>—Perform the test with 0.25 g of L-Arginine Hydrochloride, using the distillation under reduced pressure. Prepare the control solution with 5.0 mL of Standard Ammonium Solution (not more than 0.02%).

(4) Heavy metals <1.07>—Proceed with 1.0 g of L-Arginine Hydrochloride according to Method 1, and perform the test. Prepare the control solution with 2.0 mL of Standard Lead Solution (not more than 20 ppm).

(5) Arsenic <1.11>—Prepare the test solution with 1.0 g of L-Arginine Hydrochloride according to Method 1, and perform the test (not more than 2 ppm).

(6) Related substances—Dissolve 0.20 g of L-Arginine Hydrochloride in 10 mL of water, and use this solution as the sample solution. Pipet 1 mL of the sample solution, and add water to make exactly 10 mL. Pipet 1 mL of this solution, add water to make exactly 25 mL, and use this solution as the standard solution. Perform the test with these solutions as directed under Thin-layer Chromatography <2.03>. Spot 5 μ L each of the sample solution and standard solution on a plate of silica gel for thin-layer chromatography. Develop the plate with a mixture of ethanol (99.5), water, 1-butanol and ammonia water (28) (2:1:1:1) to a distance of about 10 cm, and dry the plate at 100°C for 30 minutes. Spray evenly a solution of ninhydrin in acetone (1 in 50) on the plate, and heat the plate at 80°C for 5 minutes: the spots other than the principal spot obtained from the sample solution are not more intense than the spot from the standard solution.

Loss on drying <2.41> Not more than 0.20% (1 g, 105°C, 3 hours).

Residue on ignition <2.44> Not more than 0.1% (1 g).

Assay Weigh accurately about 0.1 g of L-Arginine Hydrochloride, previously dried, dissolve in 2 mL of formic acid, add exactly 15 mL of 0.1 mol/L perchloric acid VS, and heat on a water bath for 30 minutes. After cooling, add 45 mL of acetic acid (100), and titrate <2.50> the excess perchloric acid with 0.1 mol/L sodium acetate VS (potentiometric titration). Perform a blank determination in the same manner.

Each mL of 0.1 mol/L perchloric acid VS
= 10.53 mg of $C_6H_{14}N_4O_2 \cdot HCl$

Containers and storage Containers—Tight containers.

L-Arginine Hydrochloride Injection

L-アルギニン塩酸塩注射液

L-Arginine Hydrochloride Injection is an aqueous injection.

It contains not less than 9.5 w/v% and not more than 10.5 w/v% of L-arginine hydrochloride ($C_6H_{14}N_4O_2 \cdot HCl$: 210.66).

Method of preparation

L-Arginine Hydrochloride	100 g
Water for Injection or Sterile Water for Injection in Containers	a sufficient quantity
To make 1000 mL	

Prepare as directed under Injections, with the above ingredients.

No preservative is added.

Description L-Arginine Hydrochloride Injection is a clear, colorless liquid.

Identification (1) To 5 mL of a solution of L-Arginine Hydrochloride Injection (1 in 100) add 1 mL of ninhydrin TS, and heat for 3 minutes: a blue-purple color develops.

(2) To 5 mL of a solution of L-Arginine Hydrochloride Injection (1 in 10) add 2 mL of sodium hydroxide TS and 1 to 2 drops of a solution of 1-naphthol in ethanol (95) (1 in 1000), allow to stand for 5 minutes, and add 1 to 2 drops of sodium hypochlorite TS: a red-orange color develops.

pH <2.54> 5.0 – 6.0

Bacterial endotoxins <4.01> Less than 0.50 EU/mL.

Extractable volume <6.05> It meets the requirement.

Foreign insoluble matter <6.06> Perform the test according to Method 1: it meets the requirement.

Insoluble particulate matter <6.07> It meets the requirement.

Sterility <4.06> Perform the test according to the Membrane filtration method: it meets the requirement.

Assay Pipet 20 mL of L-Arginine Hydrochloride Injection, add 7.5 mol/L hydrochloric acid TS to make exactly 100 mL, and determine the optical rotation α_D as directed under Optical Rotation Determination <2.49> at $20 \pm 1^\circ C$ in a 100-mm cell.

Amount (mg) of L-arginine hydrochloride ($C_6H_{14}N_4O_2 \cdot HCl$)
= $\alpha_D \times 4444$

Containers and storage Containers—Hermetic containers.

Arotinolol Hydrochloride

アロチノロール塩酸塩

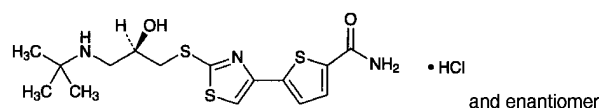

$C_{15}H_{21}N_3O_2S_3 \cdot HCl$: 408.00
5-[2-[(2*RS*)-3-(1,1-Dimethylethyl)amino]-
2-hydroxypropylsulfanyl]-1,3-thiazol-4-yl]thiophene-
2-carboxamide monohydrochloride
[68377-91-3]

Arotinolol Hydrochloride, when dried, contains not less than 99.0% of arotinolol hydrochloride ($C_{15}H_{21}N_3O_2S_3 \cdot HCl$).

Description Arotinolol Hydrochloride occurs as a white to light yellow crystalline powder.

It is freely soluble in dimethylsulfoxide, slightly soluble in methanol and in water, very slightly soluble in ethanol (99.5), and practically insoluble in diethyl ether.

A solution of Arotinolol Hydrochloride in methanol (1 in 125) does not show optical rotation.

Identification (1) Determine the absorption spectrum of a solution of Arotinolol Hydrochloride in methanol (1 in 75,000) as directed under Ultraviolet-visible Spectrophotometry <2.24>, and compare the spectrum with the Reference Spectrum: both spectra exhibit similar intensities of absorption at the same wavelengths.

(2) Determine the infrared absorption spectrum of Arotinolol Hydrochloride, previously dried, as directed in the potassium bromide disk method under Infrared Spectrophotometry <2.25>, and compare the spectrum with the Reference Spectrum: both spectra exhibit similar intensities of absorption at the same wave numbers.

(3) A solution of Arotinolol Hydrochloride (1 in 200) responds to Qualitative Tests <1.09> (2) for chloride.

Purity (1) Heavy metals <1.07>—Proceed with 1.0 g of Arotinolol Hydrochloride according to Method 2, and perform the test. Prepare the control solution with 1.0 mL of Standard Lead Solution (not more than 10 ppm).

(2) Related substances—Dissolve 0.05 g of Arotinolol Hydrochloride in 10 mL of methanol, and use this solution as the sample solution. Pipet 1 mL of the sample solution, add methanol to make exactly 100 mL. Pipet 1 mL of this solution, add methanol to make exactly 10 mL, and use this solution as the standard solution. Perform the test with these solutions as directed under Thin-layer Chromatography <2.03>. Spot 40 μ L each of the sample solution and standard solution on a plate of silica gel with fluorescent indicator for thin-layer chromatography. Develop the plate with a mixture of chloroform, methanol, acetone and ammonia solution (28) (30:10:10:1) to a distance of about 12 cm, and air-dry the plate. Examine under ultraviolet light (main wavelength: 254 nm): the spots other than the principal spot obtained from the sample solution are not more intense than the spot from the standard solution.

Loss on drying <2.41> Not more than 0.20% (1 g, in vacuum, 105°C, 4 hours).

Residue on ignition <2.44> Not more than 0.1% (1 g).

Assay Weigh accurately about 1.5 g of Arotinolol Hydrochloride, previously dried, dissolve in dimethylsulfoxide to make exactly 25 mL. Pipet 5 mL of this solution, add 100 mL of water and 5 mL of sodium hydroxide TS, and extract with three 50-mL portions of dichloromethane. Filter each dichloromethane extract through a pledget of absorbent cotton with anhydrous sodium sulfate on it. Evaporate combined filtrate to dryness in vacuum. Dissolve the residue in 70 mL of acetic acid (100), and titrate <2.50> with 0.05 mol/L perchloric acid VS (potentiometric titration). Perform a blank determination in the same manner, and make any necessary correction.

Each mL of 0.05 mol/L perchloric acid VS
= 20.40 mg of $C_{15}H_{21}N_3O_2S_3 \cdot HCl$

Containers and storage Containers—Tight containers.

Storage—Light-resistant.

Arsenical Paste

亜ヒ酸パスタ

Arsenical Paste contains not less than 36.0% and not more than 44.0% of arsenic trioxide (As_2O_3 : 197.84).

Method of preparation

Arsenic Trioxide, finely powdered	40 g
Procaine Hydrochloride, finely powdered	10 g
Hydrophilic Cream	30 g
Clove Oil	a suitable quantity
Medicinal Carbon	a suitable quantity

To make 100 g

Mix Arsenic Trioxide and Procaine Hydrochloride with Hydrophilic Cream, and add Clove Oil to make a suitably viscous liquid, followed by Medicinal Carbon for coloring.

Description Arsenical Paste is grayish black and has the odor of clove oil.

Identification (1) Place 0.1 g of Arsenical Paste in a small flask, add 5 mL of fuming nitric acid and 5 mL of sulfuric acid, and heat over a flame until the reacting liquid becomes colorless and white fumes begin to evolve. After cooling, add the reacting liquid to 20 mL of water cautiously, and add 10 mL of hydrogen sulfide TS while warming: a yellow precipitate is produced (arsenic trioxide).

(2) Shake thoroughly 0.5 g of Arsenical Paste with 25 mL of diethyl ether, 5 mL of dilute hydrochloric acid and 20 mL of water, separate the water layer, and filter: 5 mL of the filtrate responds to Qualitative Tests <1.09> for primary aromatic amines (procaine hydrochloride).

(3) Shake thoroughly 0.5 g of Arsenical Paste with 25 mL of diethyl ether and 25 mL of water, separate the water layer, filter, and use the filtrate as the sample solution. Dissolve 0.01 g of procaine hydrochloride in 5 mL of water, and use this solution as the standard solution. Perform the test with these solutions as directed under Thin-layer Chromatography <2.03>. Spot 5 μ L each of the sample solution and standard solution on a plate of silica gel with fluorescent indicator for thin-layer chromatography. Develop the plate with a mixture of ethyl acetate, ethanol (99.5) and ammonia solution (28) (50:5:1) to a distance of about 10 cm, and air-dry the plate. Examine under ultraviolet light (main wavelength: 254 nm): the spots obtained from the sample solution and standard solution exhibit the same R_f value.

Assay Weigh accurately about 0.3 g of Arsenical Paste into a 150-mL Kjeldahl flask, add 5 mL of fuming nitric acid and 10 mL of sulfuric acid, and shake thoroughly. Heat cautiously the mixture, gently at first, and then continue strong heating, until red fumes of nitrogen oxide are sparingly evolved. After cooling, add 5 mL of fuming nitric acid, heat again until red fumes of nitrogen oxide are no longer evolved and the reacting liquid becomes clear, and cool. Add 30 mL of a saturated solution of ammonium oxalate monohydrate, heat again until white fumes of sulfuric acid are evolved, and continue the heating for 10 minutes. Decompose completely oxalic acid, cool, transfer cautiously the colorless reacting liquid to a glass-stoppered flask, containing 40 mL of water. Wash thoroughly the Kjeldahl flask with 60 mL of water, add the washings to the content of the glass-stoppered flask, and cool. Dissolve 3 g of potassium iodide in this solution,

allow to stand in a dark place at room temperature for 45 minutes, and titrate <2.50> the liberated iodine with 0.1 mol/L sodium thiosulfate VS (indicator: 5 mL of starch TS). Perform a blank determination in the same manner, and make any necessary correction.

Each mL of 0.1 mol/L sodium thiosulfate VS
= 4.946 mg of As₂O₃

Containers and storage Containers—Tight containers.

Arsenic Trioxide

三酸化二ヒ素

As₂O₃: 197.84

Arsenic Trioxide, when dried, contains not less than 99.5% of arsenic trioxide (As₂O₃).

Description Arsenic Trioxide occurs as a white powder.

It is odorless. It is practically insoluble in water, in ethanol (95) and in diethyl ether.

It dissolves in sodium hydroxide TS.

Identification Dissolve 0.2 g of Arsenic Trioxide in 40 mL of water by heating on a water bath: the solution responds to Qualitative Tests <1.09> for arsenite.

Purity Clarity of solution—To 1.0 g of Arsenic Trioxide add 10 mL of ammonia TS, and heat gently: the solution is clear.

Loss on drying <2.41> Not more than 0.5% (1 g, 105°C, 3 hours).

Assay Weigh accurately about 0.15 g of Arsenic Trioxide, previously dried, dissolve in 20 mL of a solution of sodium hydroxide (1 in 25), by warming, if necessary. Add 40 mL of water and 2 drops of methyl orange TS, then add dilute hydrochloric acid until the color of the solution becomes light red. Add 2 g of sodium hydrogen carbonate and 50 mL of water to this solution, and titrate <2.50> with 0.05 mol/L iodine VS (indicator: 3 mL of starch TS).

Each mL of 0.05 mol/L iodine VS = 4.946 mg of As₂O₃

Containers and storage Containers—Tight containers.

Ascorbic Acid

Vitamin C

アスコルビン酸

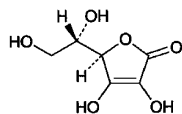

C₆H₈O₆: 176.12

L-threo-Hex-2-enono-1,4-lactone

[50-81-7]

Ascorbic Acid, when dried, contains not less than 99.0% of L-ascorbic acid (C₆H₈O₆).

Description Ascorbic Acid occurs as white crystals or a white crystalline powder. It is odorless, and has an acid taste.

It is freely soluble in water, sparingly soluble in ethanol (95), and practically insoluble in diethyl ether.

Melting point: about 190°C (with decomposition).

Identification (1) To 5 mL each of a solution of Ascorbic Acid (1 in 50) add 1 drop of potassium permanganate TS or 1 to 2 drops of 2,6-dichloroindophenol sodium TS: the color of the solution is discharged immediately in each case.

(2) Dissolve 0.1 g of Ascorbic Acid in 100 mL of a solution of metaphosphoric acid (1 in 50). To 5 mL of the solution add iodine TS until the color of the solution becomes light yellow. Then add 1 drop of a solution of copper (II) sulfate pentahydrate (1 in 1000) and 1 drop of pyrrole, and warm the mixture at 50°C for 5 minutes: a blue color develops.

Optical rotation <2.49> [α]_D²⁰: +20.5 – +21.5° (2.5 g, water, 25 mL, 100 mm).

pH <2.54> Dissolve 1.0 g of Ascorbic Acid in 20 mL of water: the pH of this solution is between 2.2 and 2.5.

Purity (1) Clarity and color of solution—Dissolve 1.0 g of Ascorbic Acid in 20 mL of water: the solution is clear and colorless.

(2) Heavy metals <1.07>—Perform the test with 1.0 g of Ascorbic Acid according to Method 1. Prepare the control solution with 2.0 mL of Standard Lead Solution (not more than 20 ppm).

Loss on drying <2.41> Not more than 0.20% (1 g, silica gel, 24 hours).

Residue on ignition <2.44> Not more than 0.1% (1 g).

Assay Weigh accurately about 0.2 g of Ascorbic Acid, previously dried, dissolve in 50 mL of a solution of metaphosphoric acid (1 in 50), and titrate <2.50> with 0.05 mol/L iodine VS (indicator: 1 mL of starch TS).

Each mL of 0.05 mol/L iodine VS
= 8.806 mg of C₆H₈O₆

Containers and storage Containers—Tight containers.

Storage—Light-resistant.

Ascorbic Acid Injection

Vitamin C Injection

アスコルビン酸注射液

Ascorbic Acid Injection is an aqueous injection.

It contains not less than 95.0% and not more than 115.0% of the labeled amount of L-ascorbic acid (C₆H₈O₆: 176.12).

Method of preparation Prepare as directed under Injections, with the sodium salt of Ascorbic Acid.

Description Ascorbic Acid Injection occurs as a clear, colorless liquid.

Identification (1) Measure a volume of Ascorbic Acid Injection, equivalent to 0.5 g of Ascorbic Acid, and add water to make 25 mL. Proceed with 5 mL each of the solution as directed in the Identification (1) under Ascorbic Acid.

(2) Measure a volume of Ascorbic Acid Injection, equivalent to 5 mg of Ascorbic Acid. Add a solution of metaphosphoric acid (1 in 50) to make 5 mL, and proceed

with this solution as directed in the Identification (2) under Ascorbic Acid.

(3) Ascorbic Acid Injection responds to Qualitative Tests (1) for sodium salt.

pH <2.54> 5.6 – 7.4

Bacterial endotoxins <4.01> Less than 0.15 EU/mg.

Extractable volume <6.05> It meets requirement.

Foreign insoluble matter <6.06> Perform the test according to Method 1: it meets the requirement.

Insoluble particulate matter <6.07> It meets the requirement.

Sterility <4.06> Perform the test according to the Membrane filtration method: it meets the requirement.

Assay Measure exactly a volume of Ascorbic Acid Injection, equivalent to about 0.1 g of L-ascorbic acid ($C_6H_8O_6$), previously diluted with metaphosphoric acid-acetic acid TS, if necessary, and add metaphosphoric acid-acetic acid TS to make exactly 200 mL. Measure exactly 2 mL of the solution, and shake with 8 mL of metaphosphoric acid-acetic acid TS and 2 mL of hydrogen peroxide TS. Titrate <2.50> with 2,6-dichloroindophenol sodium TS for titration until a light red color persists for 5 seconds. Perform a blank determination in the same manner, and make any necessary correction.

Each mL of 2, 6-dichlorophenol-indophenol sodium TS for titration
= A mg of $C_6H_8O_6$

A is decided by the following standardization of 2,6-dichloroindophenol sodium TS for titration.

2,6-Dichlorophenol-indophenol sodium TS for titration:

Preparation—Dissolve 42 mg of sodium hydrogen carbonate in 50 mL of water, add 0.5 g of 2,6-dichloroindophenol sodium dihydrate and water to make 200 mL, and filter. Prepare before use.

Standardization—Weigh accurately about 50 mg of Ascorbic Acid RS, previously dried in a desiccator (silica gel) for 24 hours, and dissolve in metaphosphoric acid-acetic acid TS to make exactly 100 mL. Pipet 2 mL of this solution, shake with 8 mL of metaphosphoric acid-acetic acid TS and 2 mL of hydrogen peroxide TS, and titrate <2.50> with 2,6-dichloroindophenol sodium TS for titration until a light red color persists for 5 seconds. Perform a blank determination in the same manner, and make any necessary correction. Calculate the quantity (A mg) of L-ascorbic acid ($C_6H_8O_6$) equivalent to 1 mL of this test solution.

Containers and storage Containers—Hermetic containers.

Storage—Under nitrogen atmosphere.

Ascorbic Acid Powder

Vitamin C Powder

アスコルビン酸散

Ascorbic Acid Powder contains not less than 95.0% and not more than 120.0% of the labeled amount of L-ascorbic acid ($C_6H_8O_6$; 176.12).

Method of preparation Prepare as directed under Granules or Powders, with Ascorbic Acid.

Identification (1) Weigh a portion of Ascorbic Acid Pow-

der, equivalent to 0.5 g of Ascorbic Acid, add 30 mL of water, shake for 1 minute, and filter. Proceed with 5 mL each of the filtrate as directed in the Identification (1) under Ascorbic Acid.

(2) Weigh a portion of Ascorbic Acid Powder, equivalent to about 0.01 g of Ascorbic Acid, add 10 mL of a solution of metaphosphoric acid (1 in 50), shake for 1 minute, and filter. Proceed with 5 mL of the filtrate as directed in the Identification (2) under Ascorbic Acid.

Purity Rancidity—Ascorbic Acid Powder is free from any unpleasant or rancid odor and taste.

Assay Weigh accurately a portion of Ascorbic Acid Powder, equivalent to about 0.1 g of L-ascorbic acid ($C_6H_8O_6$), extract with several successive portions of metaphosphoric acid-acetic acid TS, combine the extracts, and filter. Wash the residue with metaphosphoric acid-acetic acid TS. Combine the filtrates and washings, and add metaphosphoric acid-acetic acid to make exactly 200 mL. Pipet 2 mL of the solution, and shake with 8 mL of metaphosphoric acid-acetic acid TS and 2 mL of hydrogen peroxide TS. Titrate <2.50> with 2,6-dichloroindophenol sodium TS for titration until a light red color persists for 5 seconds. Perform a blank determination in the same manner, and make any necessary correction.

Each mL of 2,6-dichlorophenol-indophenol sodium TS for titration
= A mg of $C_6H_8O_6$

A is decided by the following standardization of 2,6-dichloroindophenol sodium TS for titration.

2,6-Dichlorophenol-indophenol sodium TS for titration:

Preparation—Dissolve 42 mg of sodium hydrogen carbonate in 50 mL of water, add 0.05 g of 2,6-dichloroindophenol sodium dihydrate and water to make 200 mL, and filter. Prepare before use.

Standardization—Weigh accurately about 50 mg of Ascorbic Acid RS, previously dried in a desiccator (silica gel) for 24 hours, and dissolve in metaphosphoric acid-acetic acid TS to make exactly 100 mL. Pipet 2 mL of this solution, shake with 8 mL of metaphosphoric acid-acetic acid TS and 2 mL of hydrogen peroxide TS, and titrate <2.50> with 2,6-dichloroindophenol sodium TS for titration until a light red color persists for 5 seconds. Perform a blank determination in the same manner, and make any necessary correction. Calculate the quantity (A mg) of L-ascorbic acid ($C_6H_8O_6$) equivalent to 1 mL of this test solution.

Containers and storage Containers—Tight containers.

Ascorbic Acid and Calcium Pantothenate Tablets

アスコルビン酸・パントテン酸カルシウム錠

Ascorbic Acid and Calcium Pantothenate Tablets contain not less than 95.0% and not more than 105.0% of the labeled amount of L-ascorbic acid ($C_6H_8O_6$; 176.12) and not less than 93.0% and not more than 107.0% of the labeled amount of calcium pantothenate ($C_{18}H_{32}CaN_2O_{10}$; 476.53).

Method of preparation Prepare as directed under Tablets, with Ascorbic Acid and Calcium Pantothenate.

Identification (1) To a quantity of powdered Ascorbic

Acid and Calcium Pantothenate Tablets, equivalent to 0.5 g of Ascorbic Acid, add 30 mL of water, shake for 1 minute, and filter. Proceed as directed in the Identification (1) under Ascorbic Acid using 5 mL each of the filtrate.

(2) To a quantity of powdered Ascorbic Acid and Calcium Pantothenate Tablets, equivalent to 3 mg of Calcium Pantothenate, add 20 mL of ethanol (95), shake vigorously for 10 minutes, centrifuge, and use the supernatant liquid as the sample solution. Separately, dissolve 3 mg of calcium pantothenate in 20 mL of ethanol (95), and use this solution as the standard solution. Perform the test with these solutions as directed under Thin-layer Chromatography <2.03>. Spot 10 μ L each of the sample solution and standard solution on a plate of silica gel for thin-layer chromatography. Develop the plate with a mixture of ethyl acetate, methanol and dilute acetic acid (5:3:2) to a distance of about 10 cm, and air-dry the plate. Spray evenly a solution of ninhydrin in ethanol (95) (1 in 200) on the plate, and heat the plate at 120°C for 20 minutes: one of the spots obtained from the sample solution and the spot from the standard solution are purple in color and their *R_f* value are the same.

Uniformity of dosage units <6.02> (1) L-Ascorbic acid—Perform the Mass variation test, or the Content uniformity test according to the following method: it meets the requirement.

To 1 tablet of Ascorbic Acid and Calcium Pantothenate Tablets add 100 mL of a solution of metaphosphoric acid (1 in 50), stir thoroughly, and titrate <2.50> with 0.05 mol/L iodine VS (indicator: 1 mL of starch TS).

Each mL of 0.05 mol/L iodine VS = 8.806 mg of $C_6H_8O_6$

(2) Calcium pantothenate—Perform the test according to the following method: it meets the requirement of the Content uniformity test.

To 1 tablet of Ascorbic Acid and Calcium Pantothenate Tablets add exactly *V* mL of the internal standard solution so that each mL contains about 0.15 mg of calcium pantothenate ($C_{18}H_{32}CaN_2O_{10}$), shake vigorously for 15 minutes, filter through a membrane filter with a pore size not exceeding 0.45 μ m, and use the filtrate as the sample solution. Then, proceed as directed in the Assay (2).

Amount (mg) of calcium pantothenate ($C_{18}H_{32}CaN_2O_{10}$)
 $= M_S \times Q_T/Q_S \times V/200$

M_S: Amount (mg) of Calcium Pantothenate RS taken, calculated on the dried basis

Internal Standard Solution—A solution of acetaminophen (1 in 50,000).

Dissolution <6.10> (1) L-Ascorbic acid—When the test is performed at 50 revolutions per minute according to the Paddle method, using 900 mL of water as the dissolution medium, the dissolution rate in 60 minutes of Ascorbic Acid and Calcium Pantothenate Tablets is not less than 85%.

Start the test with 1 tablet of Ascorbic Acid and Calcium Pantothenate Tablets, withdraw 20 mL of the medium at the specified minute after starting the test, and filter through a membrane filter with a pore size not exceeding 0.45 μ m. Discard not less than 10 mL of the first filtrate, pipet *V* mL of the subsequent filtrate, add 1st fluid for dissolution test to make exactly *V'* mL so that each mL contains about 11 μ g of L-ascorbic acid ($C_6H_8O_6$), and use this solution as the sample solution. Separately, weigh accurately about 22 mg of Ascorbic Acid RS, previously dried in a desiccator (silica gel) for 24 hours, dissolve in water to make exactly 100 mL, and warm at 37°C for 1 hour. Pipet 5 mL of this solution, add

1st fluid for dissolution test to make exactly 100 mL, and use this solution as the standard solution. Determine the absorbances, *A_T* and *A_S*, at 243 nm of the sample solution and standard solution as directed under Ultraviolet-visible Spectrophotometry <2.24> within 1 hour after withdrawing the medium, using 1st fluid for dissolution test as the blank.

Dissolution rate (%) with respect to the labeled amount of L-ascorbic acid ($C_6H_8O_6$)

$$= M_S \times A_T/A_S \times V'/V \times 1/C \times 45$$

M_S: Amount (mg) of Ascorbic Acid RS taken

C: Labeled amount (mg) of L-ascorbic acid ($C_6H_8O_6$) in 1 tablet

(2) Calcium pantothenate—When the test is performed at 50 revolutions per minute according to the Paddle method, using 900 mL of water as the dissolution medium, the dissolution rate in 90 minutes of Ascorbic Acid and Calcium Pantothenate Tablets is not less than 75%.

Start the test with 1 tablet of Ascorbic Acid and Calcium Pantothenate Tablets, withdraw 20 mL of the medium at the specified minute after starting the test, and filter through a membrane filter with a pore size not exceeding 0.45 μ m. Discard not less than 10 mL of the first filtrate, pipet *V* mL of the subsequent filtrate, add 1st fluid for dissolution test to make exactly *V'* mL so that each mL contains about 3.3 μ g of calcium pantothenate ($C_{18}H_{32}CaN_2O_{10}$), and use this solution as the sample solution. Separately, weigh accurately about 16.5 mg of Calcium Pantothenate RS (separately determine the loss on drying <2.41> under the same conditions as Calcium Pantothenate), and dissolve in water to make exactly 100 mL. Pipet 2 mL of this solution, add water to make exactly 100 mL, and use this solution as the standard solution. Perform the test with exactly 100 μ L each of the sample solution and standard solution as directed under Liquid Chromatography <2.01> according to the following conditions, and determine the peak areas, *A_T* and *A_S*, of pantothenic acid in each solution.

Dissolution rate (%) with respect to the labeled amount of calcium pantothenate ($C_{18}H_{32}CaN_2O_{10}$)

$$= M_S \times A_T/A_S \times V'/V \times 1/C \times 18$$

M_S: Amount (mg) of Calcium Pantothenate RS taken, calculated on the dried basis

C: Labeled amount (mg) of calcium pantothenate ($C_{18}H_{32}CaN_2O_{10}$) in 1 tablet

Operating conditions—

Detector: An ultraviolet absorption photometer (wavelength: 210 nm).

Column: A stainless steel column 4.6 mm in inside diameter and 15 cm in length, packed with octadecylsilanized silicone polymer coated silica gel for liquid chromatography (5 μ m in particle diameter).

Column temperature: A constant temperature of about 35°C.

Mobile phase: Dissolve 7.80 g of sodium dihydrogen phosphate dihydrate in 900 mL of water, adjust to pH 2.6 with phosphoric acid, and add water to make 1000 mL. To 970 mL of this solution add 30 mL of acetonitrile for liquid chromatography.

Flow rate: Adjust so that the retention time of pantothenic acid is about 10 minutes.

System suitability—

System performance: When the procedure is run with 100 μ L of the standard solution under the above operating conditions, the number of theoretical plates and the symmetry factor of the peak of pantothenic acid are not less than 5000

and not more than 2.0, respectively.

System repeatability: When the test is repeated 6 times with 100 μL of the standard solution under the above operating conditions, the relative standard deviation of the peak area of pantothenic acid is not more than 2.0%.

Assay (1) L-Ascorbic acid—Weigh accurately the mass of not less than 20 tablets of Ascorbic Acid and Calcium Pantothenate Tablets, and powder. Weigh accurately a portion of the powder, equivalent to about 0.1 g of L-ascorbic acid ($\text{C}_6\text{H}_8\text{O}_6$), add 50 mL of a solution of metaphosphoric acid (1 in 50), stir thoroughly, and titrate <2.50> with 0.05 mol/L iodine VS (indicator: 1 mL of starch TS).

Each mL of 0.05 mol/L iodine VS = 8.806 mg of $\text{C}_6\text{H}_8\text{O}_6$

(2) Calcium pantothenate—Weigh accurately the mass of not less than 20 tablets of Ascorbic Acid and Calcium Pantothenate Tablets, and powder. Weigh accurately a portion of the powder, equivalent to about 3 mg of calcium pantothenate ($\text{C}_{18}\text{H}_{32}\text{CaN}_2\text{O}_{10}$), add exactly 20 mL of the internal standard solution, shake for 15 minutes, filter through a membrane filter with a pore size not exceeding 0.45 μm , and use the filtrate as the sample solution. Separately, weigh accurately about 30 mg of Calcium Pantothenate RS (separately determine the loss on drying <2.41> under the same conditions as Calcium Pantothenate), and dissolve in water to make exactly 50 mL. Pipet 5 mL of this solution, add exactly 20 mL of the internal standard solution, and use this solution as the standard solution. Perform the test with 5 μL each of the sample solution and standard solution as directed under Liquid Chromatography <2.01> according to the following conditions, and calculate the ratios, Q_T and Q_S , of the peak area of pantothenic acid to that of the internal standard.

$$\begin{aligned} \text{Amount (mg) of calcium pantothenate } (\text{C}_{18}\text{H}_{32}\text{CaN}_2\text{O}_{10}) \\ = M_S \times Q_T / Q_S \times 1/10 \end{aligned}$$

M_S : Amount (mg) of Calcium Pantothenate RS taken, calculated on the dried basis

Internal standard solution—A solution of acetaminophen (1 in 50,000).

Operating conditions—

Detector: An ultraviolet absorption photometer (wavelength: 200 nm).

Column: A stainless steel column 4.6 mm in inside diameter and 5 cm in length, packed with octadecylsilanized silica gel for liquid chromatography (3 μm in particle diameter).

Column temperature: A constant temperature of about 25°C.

Mobile phase: A mixture of 0.05 mol/L sodium dihydrogen phosphate TS and acetonitrile for liquid chromatography (97:3).

Flow rate: Adjust so that the retention time of pantothenic acid is about 3 minutes.

System suitability—

System performance: When the procedure is run with 5 μL of the standard solution under the above operating conditions, pantothenic acid and the internal standard are eluted in this order with the resolution between these peaks being not less than 4.

System repeatability: When the test is repeated 6 times with 5 μL of the standard solution under the above operating conditions, the relative standard deviation of the ratio of the peak area of pantothenic acid to that of the internal standard is not more than 1.0%.

Containers and storage Containers—Tight containers.

L-Aspartic Acid

L-アスパラギン酸

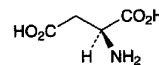

$\text{C}_4\text{H}_7\text{NO}_4$: 133.10

(2S)-2-Aminobutanedioic acid

[56-84-8]

L-Aspartic Acid, when dried, contains not less than 98.5% and not more than 101.0% of L-aspartic acid ($\text{C}_4\text{H}_7\text{NO}_4$).

Description L-Aspartic Acid occurs as white, crystals or crystalline powder.

It is sparingly soluble in water, and practically insoluble in ethanol (99.5).

It dissolves in dilute hydrochloric acid and in 0.2 mol/L sodium hydroxide TS.

Identification Determine the infrared absorption spectrum of L-Aspartic Acid as directed in the potassium bromide disk method under Infrared Spectrophotometry <2.25>, and compare the spectrum with the Reference Spectrum: both spectra exhibit similar intensities of absorption at the same wave numbers.

Optical rotation <2.49> $[\alpha]_D^{20}$: +24.0 – +26.0° (2 g, after drying, 6 mol/L hydrochloric acid TS, 25 mL, 100 mm).

pH <2.54> Dissolve 0.4 g of L-Aspartic Acid in 100 mL of water by warming, and allow to cool: between 2.5 and 3.5.

Purity (1) Clarity and color of solution—Dissolve 1.0 g of L-Aspartic Acid in 20 mL of 1 mol/L hydrochloric acid TS: the solution is clear and colorless.

(2) Chloride <1.03>—Dissolve 0.5 g of L-Aspartic Acid in 6 mL of dilute nitric acid and 20 mL of water, add water to make 50 mL, and perform the test with this solution as the test solution. Prepare the control solution with 0.30 mL of 0.01 mol/L hydrochloric acid VS (not more than 0.021%).

(3) Sulfate <1.14>—Dissolve 0.6 g of L-Aspartic Acid in 5 mL of dilute hydrochloric acid and 30 mL of water, add water to make 45 mL, and add 5 mL of barium chloride TS. Perform the test with this solution as the test solution. Prepare the control solution with 0.35 mL of 0.005 mol/L sulfuric acid VS, add 5 mL of dilute hydrochloric acid and water to make 45 mL, and add 5 mL of barium chloride (not more than 0.028%).

(4) Ammonium <1.02>—Perform the test with 0.25 g of L-Aspartic Acid. Prepare the control solution with 5.0 mL of Standard Ammonium Solution (not more than 0.02%).

(5) Heavy metals <1.07>—Proceed with 1.0 g of L-Aspartic Acid according to Method 4, and perform the test. Prepare the control solution with 1.0 mL of Standard Lead Solution (not more than 10 ppm).

(6) Iron <1.10>—Prepare the test solution with 1.0 g of L-Aspartic Acid according to Method 1, and perform the test according to Method A. Prepare the control solution with 1.0 mL of Standard Iron Solution (not more than 10 ppm).

(7) Related substances—Dissolve 0.20 g of L-Aspartic Acid in 10 mL of 0.2 mol/L sodium hydroxide TS, and use this solution as the sample solution. Pipet 1 mL of the sample solution, add water to make exactly 10 mL. Pipet 1 mL of this solution, add water to make exactly 50 mL, and use this solution as the standard solution. Perform the test with

these solutions as directed under Thin-layer Chromatography <2.03>. Spot 5 μL each of the sample solution and standard solution on a plate of silica gel for thin-layer chromatography, develop with a mixture of 1-butanol, water and acetic acid (100) (3:1:1) to a distance of about 10 cm, and dry the plate at 80°C for 30 minutes. Spray evenly a solution of ninhydrin in a mixture of methanol and acetic acid (100) (97:3) (1 in 100), and heat the plate at 80°C for 10 minutes: the spot other than the principal spot obtained from the sample solution is not more intense than the spot from the standard solution.

Loss on drying <2.41> Not more than 0.30% (1 g, 105°C, 3 hours).

Residue on ignition <2.44> Not more than 0.1% (1 g).

Assay Weigh accurately about 0.15 g of L-Aspartic Acid, previously dried, dissolve in 50 mL of water by warming. After cooling, titrate <2.50> with 0.1 mol/L sodium hydroxide VS (potentiometric titration). Perform a blank determination in the same manner, and make any necessary correction.

Each mL of 0.1 mol/L sodium hydroxide VS
= 13.31 mg of $\text{C}_4\text{H}_7\text{NO}_4$

Containers and storage Containers—Tight containers.

Aspirin

Acetylsalicylic Acid

アスピリン

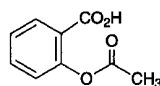

$\text{C}_9\text{H}_8\text{O}_4$: 180.16
2-Acetoxybenzoic acid
[50-78-2]

Aspirin, when dried, contains not less than 99.5% of aspirin ($\text{C}_9\text{H}_8\text{O}_4$).

Description Aspirin occurs as white, crystals, granules or powder. It is odorless, and has a slight acid taste.

It is freely soluble in ethanol (95) and in acetone, soluble in diethyl ether, and slightly soluble in water.

It dissolves in sodium hydroxide TS and in sodium carbonate TS.

In moist air, it gradually hydrolyzes to salicylic acid and acetic acid.

Melting point: about 136°C (bath fluid is heated at 130°C previously).

Identification (1) Boil 0.1 g of Aspirin in 5 mL of water for 5 to 6 minutes, cool, and add 1 to 2 drops of iron (III) chloride TS: a red-purple color is produced.

(2) Boil 0.5 g of Aspirin in 10 mL of sodium carbonate TS for 5 minutes, and add 10 mL of dilute sulfuric acid: the odor of acetic acid is perceptible, and a white precipitate is produced. Filter the precipitate, add 3 mL of ethanol (95) and 3 mL of sulfuric acid to the filtrate, and heat: the odor of ethyl acetate is perceptible.

Purity (1) Clarity of solution—Dissolve 0.5 g of Aspirin in 10 mL of warm sodium carbonate TS: the solution is clear.

(2) Salicylic acid—Dissolve 2.5 g of Aspirin in 25 mL of ethanol (95), and add 1.0 mL of this solution to a solution which is prepared by transferring 1 mL of a freshly prepared dilute ammonium iron (III) sulfate TS to a Nessler tube and diluting with water to 50 mL. Allow to stand for 30 seconds: the solution has no more color than the following control solution.

Control solution: Dissolve 0.100 g of salicylic acid in water, and add 1 mL of acetic acid (100) and water to make 1000 mL. Add 1.0 mL of this solution to a solution which is prepared by transferring 1 mL of freshly prepared dilute ammonium iron (III) sulfate TS and 1 mL of ethanol (95) to a Nessler tube and diluting with water to 50 mL. Allow to stand for 30 seconds.

(3) Chloride <1.03>—Boil 1.8 g of Aspirin in 75 mL of water for 5 minutes, cool, add water to make 75 mL, and filter. To 25 mL of the filtrate add 6 mL of dilute nitric acid and water to make 50 mL, and perform the test using this solution as the test solution. Prepare the control solution with 0.25 mL of 0.01 mol/L hydrochloric acid VS (not more than 0.015%).

(4) Sulfate <1.14>—To 25 mL of the filtrate obtained in (3) add 1 mL of dilute hydrochloric acid and water to make 50 mL. Perform the test using this solution as the test solution. Prepare the control solution with 0.50 mL of 0.005 mol/L sulfuric acid VS (not more than 0.040%).

(5) Heavy metals <1.07>—Dissolve 2.5 g of Aspirin in 30 mL of acetone, add 2 mL of dilute acetic acid and water to make 50 mL, and perform the test using this solution as the test solution. Prepare the control solution with 2.5 mL of Standard Lead Solution, 30 mL of acetone, 2 mL of dilute acetic acid and water to make 50 mL (not more than 10 ppm).

(6) Readily carbonizable substances <1.15>—Weigh 0.5 g of Aspirin, and perform the test. The solution has no more color than Matching Fluid Q.

Loss on drying <2.41> Not more than 0.5% (3 g, silica gel, 5 hours).

Residue on ignition <2.44> Not more than 0.1% (1 g).

Assay Weigh accurately about 1.5 g of Aspirin, previously dried, add exactly 50 mL of 0.5 mol/L sodium hydroxide VS, and boil gently for 10 minutes under a reflux condenser with a carbon dioxide-absorbing tube (soda lime). Cool, and titrate <2.50> immediately the excess sodium hydroxide with 0.25 mol/L sulfuric acid VS (indicator: 3 drops of phenolphthalein TS). Perform a blank determination in the same manner.

Each mL of 0.5 mol/L sodium hydroxide VS
= 45.04 mg of $\text{C}_9\text{H}_8\text{O}_4$

Containers and storage Containers—Well-closed containers.

Aspirin Tablets

Acetylsalicylic Acid Tablets

アスピリン錠

Aspirin Tablets contain not less than 95.0% and not more than 105.0% of the labeled amount of aspirin ($\text{C}_9\text{H}_8\text{O}_4$: 180.16).

Method of preparation Prepare as directed under Tablets,

with Aspirin.

Identification (1) Weigh a quantity of powdered Aspirin Tablets, equivalent to 0.1 g of Aspirin, add 10 mL of water, and boil for 5 to 6 minutes. After cooling, filter, and add 1 to 2 drops of iron (III) chloride TS to the filtrate: a red-violet color develops.

(2) Weigh a portion of powdered Aspirin Tablets, equivalent to 0.5 g of Aspirin, extract with two 10-mL portions of warm ethanol (95), and filter the combined extracts. Evaporate the filtrate to dryness, and boil the residue with 10 mL of sodium carbonate TS for 5 minutes. Proceed as directed in the Identification (2) under Aspirin.

Purity Salicylic acid—Take a portion of the powdered Aspirin Tablets, equivalent to 1.0 g of Aspirin, shake with 15 mL of ethanol (95) for 5 minutes, filter, discard the first 5 mL of the filtrate, and add 1.0 mL of the subsequent filtrate to a solution which is prepared by transferring 1 mL of freshly prepared dilute ammonium iron (III) sulfate TS to a Nessler tube and diluting with water to make 50 mL. Proceed as directed in the Purity (2) under Aspirin.

Assay Weigh accurately and powder not less than 20 Aspirin Tablets. Weigh accurately a portion of the powder, equivalent to about 1.5 g of aspirin ($C_9H_8O_4$), add exactly 50 mL of 0.5 mol/L sodium hydroxide VS, and proceed as directed in the Assay under Aspirin.

$$\begin{aligned} \text{Each mL of 0.5 mol/L sodium hydroxide VS} \\ = 45.04 \text{ mg of } C_9H_8O_4 \end{aligned}$$

Containers and storage Containers—Well-closed containers.

Aspirin Aluminum

Aluminum Acetylsalicylate

アスピリンアルミニウム

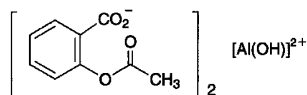

$C_{18}H_{15}AlO_9$; 402.29

Bis(2-acetoxybenzoato)hydroxoaluminium
[23413-80-1]

Aspirin Aluminum contains not less than 83.0% and not more than 90.0% of aspirin ($C_9H_8O_4$: 180.16), and not less than 6.0% and not more than 7.0% of aluminum (Al: 26.98), calculated on the anhydrous basis.

Description Aspirin Aluminum occurs as a white crystalline powder. It is odorless or has a slight, acetic odor.

It is practically insoluble in water, in methanol, in ethanol (95) and in diethyl ether.

It dissolves, with decomposition, in sodium hydroxide TS and in sodium carbonate TS.

Identification (1) Dissolve 0.1 g of Aspirin Aluminum in 10 mL of sodium hydroxide TS by heating, if necessary. Neutralize 2 mL of the solution with hydrochloric acid, and add 1 to 2 drops of iron (III) chloride TS: a red-purple color develops.

(2) Determine the absorption spectrum of the sample solution obtained in the Assay (1) as directed under Ultraviolet-visible Spectrophotometry <2.24>: it exhibits a maximum

between 277 nm and 279 nm.

(3) Place 2 g of Aspirin Aluminum in a platinum crucible, and ignite until charred. To the residue add 1 g of anhydrous sodium carbonate, and ignite for 20 minutes. After cooling, to the residue add 15 mL of dilute hydrochloric acid, shake, and filter: the filtrate responds to Qualitative Tests <1.09> for aluminum salt.

Purity (1) Salicylate—Using A_{T2} and A_{S2} obtained in the Assay (1), calculate the amount of salicylate [as salicylic acid ($C_7H_6O_3$: 138.12)] by the following equation: salicylate content is not more than 7.5%, calculated on the anhydrous basis.

$$\begin{aligned} \text{Amount (mg) of salicylic acid } (C_7H_6O_3) \\ = M_S \times A_{T2}/A_{S2} \times 1/4 \end{aligned}$$

M_S : Amount (mg) of salicylic acid for assay taken

(2) Heavy metals <1.07>—Place 2.0 g of Aspirin Aluminum in a porcelain crucible, cover the crucible loosely, and ignite at a low temperature until charred. After cooling, add 2 mL of nitric acid and 1 mL of sulfuric acid to the content of the crucible, heat gently the crucible until white fumes are evolved, and continue the heating until white fumes are no longer evolved, then ignite between 500°C and 600°C until the carbon is incinerated. When the incineration is not completed, add 2 mL of nitric acid and 1 mL of sulfuric acid, and heat gently in the same manner, then ignite between 500°C and 600°C to incinerate completely. After cooling, add 2 mL of hydrochloric acid, and proceed as directed in Method 2, and perform the test. Prepare the control solution by using the same quantities of the same reagents as directed for the preparation of the test solution, and add 2.0 mL of Standard Lead Solution and water to make 50 mL (not more than 10 ppm).

(3) Arsenic <1.11>—Dissolve 1.0 g of Aspirin Aluminum in 15 mL of sodium hydroxide TS. To this solution add 1 drop of phenolphthalein TS, and with stirring, add dropwise hydrochloric acid until the red color of the solution disappears. Then add 2 mL of hydrochloric acid, cool with occasional shaking for 10 minutes, and filter with a glass filter (G3). Wash the residue with two 5 mL portions of 1 mol/L hydrochloric acid TS, and combine the filtrate and the washings. Use this solution as the test solution, and perform the test (not more than 2 ppm).

Water <2.48> Not more than 4.0% (0.15 g, direct titration).

Assay (1) Aspirin—Weigh accurately about 0.1 g of Aspirin Aluminum, add 40 mL of sodium fluoride TS, and shake for 5 minutes. Allow the solution to stand for 10 minutes with frequent shaking. Extract the solution with six 20-mL portions of chloroform. Combine all chloroform extracts, and add chloroform to make exactly 200 mL. Measure exactly 10 mL of this solution, add chloroform to make exactly 100 mL, and use this solution as the sample solution. Separately, weigh accurately about 90 mg of salicylic acid for assay, previously dried in a desiccator (silica gel) for 3 hours, and dissolve in chloroform to make exactly 200 mL. Measure exactly 5 mL of this solution, add chloroform to make exactly 200 mL, and use this solution as the standard solution (1). Then weigh accurately about 90 mg of Aspirin RS, previously dried in a desiccator (silica gel) for 5 hours, and dissolve in chloroform to make exactly 200 mL. Measure exactly 10 mL of this solution, add chloroform to make exactly 100 mL, and use this solution as the standard solution (2). Perform the test with these solutions as directed under Ultraviolet-visible Spectrophotometry <2.24>. Determine the absorbances, A_{T1} and A_{S1} , of the sample solution and standard

solution (1) at 278 nm, and absorbances, A_{T2} and A_{S2} , of these solution, at 308 nm, respectively. Then determine the absorbance A_{S3} of the standard solution (2) at 278 nm.

$$\text{Amount (mg) of aspirin (C}_9\text{H}_8\text{O}_4) \\ = M_S \times \left(\frac{A_{T1} - \frac{A_{T2} \times A_{S1}}{A_{S2}}}{A_{S3}} \right)$$

M_S : Amount (mg) of Aspirin RS taken

(2) Aluminum—Weigh accurately about 0.4 g of Aspirin Aluminum, and dissolve in 10 mL of sodium hydroxide TS. Add dropwise 1 mol/L hydrochloric acid TS to adjust the solution to a pH of about 1, add 20 mL of acetic acid-ammonium acetate buffer solution (pH 3.0) and 0.5 mL of Cu-PAN TS, and heat. While boiling, titrate <2.50> with 0.05 mol/L disodium dihydrogen ethylenediamine tetraacetate VS until the color of the solution changes from red to yellow and persists for 1 minute. Perform a blank determination in the same manner, and make any necessary correction.

Each mL of 0.05 mol/L disodium dihydrogen ethylenediamine tetraacetate VS
= 1.349 mg of Al

Containers and storage Containers—Well-closed containers.

Aspoxicillin Hydrate

アスポキシシリン水和物

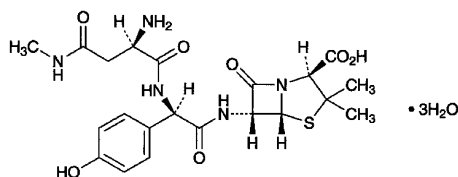

$C_{21}H_{27}N_5O_7S \cdot 3H_2O$: 547.58
(2*S*,5*R*,6*R*)-6-[(2*R*)-2-[(2*R*)-2-Amino-3-methylcarbamoylpropanoylamino]-2-(4-hydroxyphenyl)acetamino]-3,3-dimethyl-7-oxo-4-thia-1-azabicyclo[3.2.0]heptane-2-carboxylic acid trihydrate
[63358-49-6, anhydride]

Aspoxicillin Hydrate contains not less than 950 μ g (potency) and not more than 1020 μ g (potency) per mg, calculated on the anhydrous basis. The potency of Aspoxicillin Hydrate is expressed as mass (potency) of aspoxicillin ($C_{21}H_{27}N_5O_7S$): 493.53).

Description Aspoxicillin Hydrate occurs as a white, crystals or crystalline powder.

It is freely soluble in *N,N*-dimethylformamide, sparingly soluble in water, and practically insoluble in acetonitrile, in methanol and in ethanol (95).

Identification (1) Determine the absorption spectrum of a solution of Aspoxicillin Hydrate (1 in 4000) as directed under Ultraviolet-visible Spectrophotometry <2.24>, and compare the spectrum with the Reference Spectrum or the spectrum of a solution of Aspoxicillin RS prepared in the same manner as the sample solution: both spectra exhibit similar intensities of absorption at the same wavelengths.

(2) Determine the infrared absorption spectrum of Aspoxicillin Hydrate as directed in the potassium bromide disk method under Infrared Spectrophotometry <2.25>, and compare the spectrum with the Reference Spectrum or spectrum of Aspoxicillin RS: both spectra exhibit similar intensities of absorption at the same wave numbers.

Optical rotation <2.49> $[\alpha]_D^{20}$: +170 – +185° (0.2 g calculated on the anhydrous bases, water, 20 mL, 100 mm).

pH <2.54> Dissolve 1.0 g of Aspoxicillin Hydrate in 50 mL of water: the pH of the solution is between 4.2 and 5.2.

Purity (1) Clarity and color of solution—Dissolve 1.0 g of Aspoxicillin Hydrate in 50 mL of water: the solution is clear and colorless.

(2) Heavy metals <1.07>—Proceed with 2.0 g of Aspoxicillin Hydrate according to Method 2, and perform the test. Prepare the control solution with 2.0 mL of Standard Lead Solution (not more than 10 ppm).

(3) Arsenic <1.11>—Prepare the test solution with 2.0 g of Aspoxicillin Hydrate according to Method 5, and perform the test (not more than 1 ppm).

(4) Related substances—Dissolve 0.05 g of Aspoxicillin Hydrate in 10 mL of the mobile phase, and use this solution as the sample solution. Pipet 1 mL of the sample solution, add the mobile phase to make exactly 100 mL, and use this solution as the standard solution. Perform the test with exactly 10 μ L each of these solutions as directed under Liquid Chromatography <2.01> according to the following conditions, and determine the areas of each peak by the automatic integration method: the area of each peak other than aspoxicillin obtained from the sample solution is not larger than 3/10 times the peak area of aspoxicillin from the standard solution, and the total of peak areas other than aspoxicillin from the sample solution is not larger than the peak area of aspoxicillin from the standard solution.

Operating conditions—

Detector, column, column temperature, mobile phase, and flow rate: Proceed as directed in the operating conditions in the Assay.

Time span of measurement: About 6 times as long as the retention time of aspoxicillin.

System suitability—

System performance: Proceed as directed in the system suitability in the Assay.

Test for required detectability: Pipet 2 mL of the standard solution, add the mobile phase to make exactly 10 mL. Confirm that the peak area of aspoxicillin obtained with 10 μ L of this solution is equivalent to 15 to 25% of that with 10 μ L of the standard solution.

System repeatability: When the test is repeated 6 times with 10 μ L of the standard solution under the above operating conditions, the relative standard deviation of the peak areas of aspoxicillin is not more than 5%.

Water <2.48> Not less than 9.5% and not more than 13.0% (0.2 g, volumetric titration, direct titration).

Assay Weigh accurately an amount of Aspoxicillin Hydrate and Aspoxicillin RS, equivalent to about 0.1 g (potency), dissolve each in a suitable amount of water, add exactly 10 mL of the internal standard solution, 6.5 mL of acetonitrile and water to make 50 mL, and use these solutions as the sample solution and the standard solution, respectively. Perform the test with 10 μ L each of these solutions as directed under Liquid Chromatography <2.01> according to the following conditions, and calculate the ratios, Q_T and Q_S , of the peak area of aspoxicillin to that of the in-

ternal standard.

$$\text{Amount } [\mu\text{g (potency)}] \text{ of aspoxicillin (C}_{21}\text{H}_{27}\text{N}_5\text{O}_7\text{S)} \\ = M_S \times Q_T / Q_S \times 1000$$

M_S : Amount [mg (potency)] of Aspoxicillin RS taken

Internal standard solution—A solution of *N*-(3-hydroxyphenyl)acetamide (1 in 1000).

Operating conditions—

Detector: An ultraviolet absorption photometer (wavelength: 280 nm).

Column: A stainless steel column 4.6 mm in inside diameter and 15 cm in length, packed with octadecylsilanized silica gel for liquid chromatography (5 μm in particle diameter).

Column temperature: A constant temperature of about 40°C.

Mobile phase: To 130 mL of acetonitrile add potassium dihydrogenphosphate TS (pH 3.0) to make 1000 mL.

Flow rate: Adjust so that the retention time of aspoxicillin is about 3 minutes.

System suitability—

System performance: When the procedure is run with 10 μL of the standard solution under the above operating conditions, aspoxicillin and the internal standard are eluted in this order with the resolution between these peaks being not less than 8.

System repeatability: When the test is repeated 6 times with 10 μL of the standard solution under the above operating conditions, the relative standard deviation of the ratios of the peak area of aspoxicillin to that of the internal standard is not more than 0.8%.

Containers and storage Containers—Tight containers.

Atenolol

アテノロール

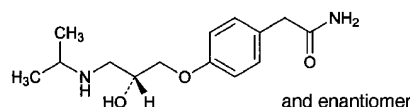

$\text{C}_{14}\text{H}_{22}\text{N}_2\text{O}_3$; 266.34

2-(4-[(2*RS*)-2-Hydroxy-3-[(1-methylethyl)amino]propyloxy]phenyl)acetamide [29122-68-7]

Atenolol, when dried, contains not less than 99.0% and not more than 101.0% of atenolol ($\text{C}_{14}\text{H}_{22}\text{N}_2\text{O}_3$).

Description Atenolol occurs as a white to pale yellow crystalline powder.

It is freely soluble in methanol and in acetic acid (100), soluble in ethanol (99.5), and slightly soluble in water.

A solution of Atenolol in methanol (1 in 25) shows no optical rotation.

Identification (1) Determine the absorption spectrum of a solution of Atenolol in methanol (1 in 50,000) as directed under Ultraviolet-visible Spectrophotometry <2.24>, and compare the spectrum with the Reference Spectrum: both spectra exhibit similar intensities of absorption at the same wavelengths.

(2) Determine the infrared absorption spectrum of Atenolol as directed in the potassium bromide disk method under Infrared Spectrophotometry <2.25>, and compare the spectrum with the Reference Spectrum: both spectra exhibit similar intensities of absorption at the same wave numbers.

Melting Point <2.60> 152 – 156°C

Purity (1) Heavy metals <1.07>—Proceed with 1.0 g of Atenolol according to Method 2, and perform the test. Prepare the control solution with 2.0 mL of Standard Lead Solution (not more than 20 ppm).

(2) Related substances—Dissolve 50 mg of Atenolol in 25 mL of the mobile phase, and use this solution as the sample solution. Pipet 1 mL of the sample solution, add the mobile phase to make exactly 200 mL, and use this solution as the standard solution. Perform the test with exactly 10 μL each of the sample solution and standard solution as directed under Liquid Chromatography <2.01> according to the following conditions, and determine each peak area by the automatic integration method: the area of the peak other than atenolol obtained from the sample solution is not larger than 1/2 times the peak area of atenolol from the standard solution, and the total area of the peaks other than atenolol from the sample solution is not larger than the peak area of atenolol from the standard solution.

Operating conditions—

Detector: An ultraviolet absorption photometer (wavelength: 226 nm).

Column: A stainless steel column 4.6 mm in inside diameter and 15 cm in length, packed with octadecylsilanized silica gel for liquid chromatography (5 μm in particle diameter).

Column temperature: A constant temperature of about 25°C.

Mobile phase: Dissolve 3.4 g of potassium dihydrogen phosphate in 1000 mL of water, and adjust to pH 3.0 with phosphoric acid. To 40 volume of this solution add 9 volume of methanol and 1 volume of tetrahydrofuran. Dissolve 1 g of sodium 1-octanesulfonate and 0.4 g of tetrabutylammonium hydrogensulfate in 1000 mL of this solution.

Flow rate: Adjust so that the retention time of atenolol is about 8 minutes.

Time span of measurement: About 4 times as long as the retention time of atenolol.

System suitability—

Test for required detectability: To exactly 10 mL of the standard solution add the mobile phase to make exactly 50 mL. Confirm that the peak area of atenolol obtained with 10 μL of this solution is equivalent to 14 to 26% of that with 10 μL of the standard solution.

System performance: When the procedure is run with 10 μL of the standard solution under the above operating conditions, the number of theoretical plates and the symmetry factor of the peak of atenolol are not less than 5000 and not more than 1.5, respectively.

System repeatability: When the test is repeated 6 times with 10 μL of the standard solution under the above operating conditions, the relative standard deviation of the peak area of atenolol is not more than 1.0%.

Loss on drying <2.41> Not more than 0.5% (1 g, 105°C, 3 hours).

Residue on ignition <2.44> Not more than 0.2% (1 g).

Assay Weigh accurately about 0.3 g of Atenolol, previously dried, dissolve in 100 mL of acetic acid (100), and titrate <2.50> with 0.1 mol/L perchloric acid VS (potentiometric titration). Perform a blank determination in the same manner, and make any necessary correction.

$$\text{Each mL of 0.1 mol/L perchloric acid VS} \\ = 26.63 \text{ mg of } \text{C}_{14}\text{H}_{22}\text{N}_2\text{O}_3$$

Containers and storage Containers—Tight containers.

Atorvastatin Calcium Hydrate

アトルバスタチンカルシウム水和物

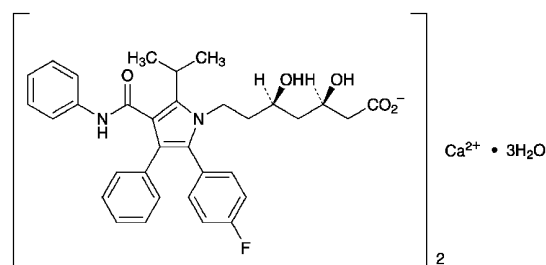

$C_{66}H_{68}CaF_2N_4O_{10} \cdot 3H_2O$: 1209.39
 Monocalcium bis[(3*R*,5*R*)-7-[2-(4-fluorophenyl)-5-(1-methylethyl)-3-phenyl-4-(phenylcarbamoyl)-1*H*-pyrrol-1-yl]-3,5-dihydroxyheptanoate] trihydrate
 [344423-98-9]

Atorvastatin Calcium Hydrate contains not less than 98.0% and not more than 102.0% of atorvastatin calcium ($C_{66}H_{68}CaF_2N_4O_{10}$: 1155.34), calculated on the anhydrous basis.

Description Atorvastatin Calcium Hydrate occurs as a white to pale yellow-white crystalline powder.

It is very soluble in methanol, freely soluble in dimethylsulfoxide, and very slightly soluble in water and in ethanol (99.5).

It gradually turns yellowish white on exposure to light.

It shows crystal polymorphism.

Identification (1) Determine the absorption spectrum of a solution of Atorvastatin Calcium Hydrate in methanol (1 in 62,500) as directed under Ultraviolet-visible Spectrophotometry <2.24>, and compare the spectrum with the Reference Spectrum or the spectrum of a solution of Atorvastatin Calcium RS prepared in the same manner as the sample solution: both spectra exhibit similar intensities of absorption at the same wavelengths.

(2) Determine the infrared absorption spectrum of Atorvastatin Calcium Hydrate as directed in the potassium bromide disk method under Infrared Spectrophotometry <2.25>, and compare the spectrum with the Reference Spectrum or the spectrum of Atorvastatin Calcium RS: both spectra exhibit similar intensities of absorption at the same wave numbers. If any difference appears between the spectra, recrystallize the sample and the reference standard according to the method otherwise specified, filter and dry the crystals, and perform the test with the crystals.

(3) A gruel-like liquid of Atorvastatin Calcium Hydrate prepared by adding a small amount of dilute hydrochloric acid responds to the Qualitative Tests <1.09> (1) for calcium salt. A solution of Atorvastatin Calcium Hydrate in a mixture of methanol and water (7:3) (1 in 250) is also responds to Qualitative Tests <1.09> (3) for calcium salt.

Optical rotation <2.49> $[\alpha]_D^{25}$: $-7 - -10^\circ$ (0.2 g, calculated on the anhydrous basis, dimethylsulfoxide, 20 mL, 100 mm).

Purity (1) Heavy metals <1.07>—Proceed with 1.0 g of Atorvastatin Calcium Hydrate according to Method 4, and perform the test. Prepare the control solution with 1.0 mL of Standard Lead Solution (not more than 10 ppm).

(2) Related substances—Dissolve 20 mg of Atorvastatin Calcium Hydrate in 20 mL of a mixture of water and acetonitrile (1:1), and use this solution as the sample solution.

Pipet 1 mL of the sample solution, add a mixture of water and acetonitrile (1:1) to make exactly 100 mL, and use this solution as the standard solution. Perform the test with exactly 20 μ L each of the sample solution and standard solution as directed under Liquid Chromatography <2.01> according to the following conditions, and determine each peak area by the automatic integration method: the area of the peak, having the relative retention time of about 0.8 to atorvastatin, obtained from the sample solution is not larger than 3/10 times the peak area of atorvastatin from the standard solution, the area of the peak other than atorvastatin and the peak mentioned above from the sample solution is not larger than 1/10 times the peak area of atorvastatin from the standard solution, and the total area of the peaks other than atorvastatin from the sample solution is not larger than the peak area of atorvastatin from the standard solution.

Operating conditions—

Detector: An ultraviolet absorption photometer (wavelength: 254 nm).

Column: A stainless steel column 4.6 mm in inside diameter and 25 cm in length, packed with octadecylsilanized silica gel for liquid chromatography (5 μ m in particle diameter).

Column temperature: A constant temperature of about 40°C.

Mobile phase A: Dissolve 10.5 g of citric acid monohydrate in 900 mL of water, adjust to pH 5.0 with ammonia solution (28), and add water to make 1000 mL. To 400 mL of this solution add 100 mL of acetonitrile and 100 mL of tetrahydrofuran.

Mobile phase B: A mixture of acetonitrile and tetrahydrofuran (1:1).

Flowing of mobile phase: Control the gradient by mixing the mobile phases A and B as directed in the following table.

Time after injection of sample (min)	Mobile phase A (vol%)	Mobile phase B (vol%)
0 – 40	93	7
40 – 80	93 → 60	7 → 40

Flow rate: Adjust so that the retention time of atorvastatin is about 16 minutes.

Time span of measurement: About 5 times as long as the retention time of atorvastatin, beginning after the solvent peak.

System suitability—

Test for required detectability: Pipet 5 mL of the standard solution, and add a mixture of water and acetonitrile (1:1) to make exactly 100 mL. Confirm that the peak area of atorvastatin obtained with 20 μ L of this solution is equivalent to 3.5 to 6.5% of that with 20 μ L of the standard solution.

System performance: When the procedure is run with 20 μ L of the standard solution under the above operating conditions, the number of theoretical plates and the symmetry factor of the peak of atorvastatin are not less than 8000 and not more than 1.5, respectively.

System repeatability: When the test is repeated 6 times with 20 μ L of the standard solution under the above operating conditions, the relative standard deviation of the peak area of atorvastatin is not more than 2.0%.

Water <2.48> 3.5 – 5.5% (50 mg, coulometric titration).

Assay Weigh accurately about 20 mg each of Atorvastatin Calcium Hydrate and Atorvastatin Calcium RS (separately determine the water <2.48> in the same manner as Atorvastatin Calcium Hydrate), dissolve each in an adequate amount

of a mixture of water and acetonitrile (1:1), add exactly 10 mL of the internal standard solution, then add a mixture of water and acetonitrile (1:1) to make 50 mL, and use these solutions as the sample solution and the standard solution, respectively. Perform the test with 10 μ L each of the sample solution and standard solution as directed under Liquid Chromatography <2.01> according to the following conditions, and calculate the ratios, Q_T and Q_S , of the peak area of atorvastatin to that of the internal standard.

$$\begin{aligned} &\text{Amount (mg) of atorvastatin calcium (C}_{66}\text{H}_{68}\text{CaF}_2\text{N}_4\text{O}_{10}) \\ &= M_S \times Q_T/Q_S \end{aligned}$$

M_S : Amount (mg) of Atorvastatin Calcium RS taken, calculated on the anhydrous basis

Internal standard solution—A solution of butyl parahydroxybenzoate in a mixture of water and acetonitrile (1:1) (1 in 1500).

Operating conditions—

Detector: An ultraviolet absorption photometer (wavelength: 254 nm).

Column: A stainless steel column 4.6 mm in inside diameter and 25 cm in length, packed with octadecylsilanized silica gel for liquid chromatography (5 μ m in particle diameter).

Column temperature: A constant temperature of about 40°C.

Mobile phase: Dissolve 10.5 g of citric acid monohydrate in 900 mL of water, adjust to pH 4.0 with ammonia solution (28), and add water to make 1000 mL. To 530 mL of this solution add 270 mL of acetonitrile and 200 mL of tetrahydrofuran.

Flow rate: Adjust so that the retention time of atorvastatin is about 10 minutes.

System suitability—

System performance: When the procedure is run with 10 μ L of the standard solution under the above operating conditions, the internal standard and atorvastatin are eluted in this order with the resolution between these peaks being not less than 5.

System repeatability: When the test is repeated 6 times with 10 μ L of the standard solution under the above operating conditions, the relative standard deviation of the ratio of the peak area of atorvastatin to that of the internal standard is not more than 1.0%.

Containers and storage Containers—Well-closed containers.

Storage—Light-resistant.

Atorvastatin Calcium Tablets

アトルバスタチンカルシウム錠

Atorvastatin Calcium Tablets contain not less than 95.0% and not more than 105.0% of the labeled amount of atorvastatin calcium hydrate (C₆₆H₆₈CaF₂N₄O₁₀·3H₂O: 1209.39).

Method of preparation Prepare as directed under Tablets, with Atorvastatin Calcium Hydrate.

Identification To a quantity of powdered Atorvastatin Calcium Tablets, equivalent to 10 mg of Atorvastatin Calcium Hydrate, add 50 mL of methanol, shake thoroughly, and centrifuge. To 2.5 mL of the supernatant liquid add methanol to make 50 mL, and determine the absorption spectrum of this solution as directed under Ultraviolet-visible Spectro-

photometry <2.24>: it exhibits a maximum between 244 nm and 248 nm.

Uniformity of dosage units <6.02> Perform the test according to the following method: it meets the requirement of the Content uniformity test.

To 1 tablet of Atorvastatin Calcium Tablets add 3V/5 mL of a mixture of water and methanol (1:1), and disintegrate the tablet by shaking. Add exactly V/10 mL of the internal standard solution, and add a mixture of water and methanol (1:1) to make V mL so that each mL contains about 0.1 mg of atorvastatin calcium hydrate (C₆₆H₆₈CaF₂N₄O₁₀·3H₂O). Centrifuge this solution, and use the supernatant liquid as the sample solution. Separately, weigh accurately about 22 mg of Atorvastatin Calcium RS (separately determine the water <2.48> in the same manner as Atorvastatin Calcium Hydrate), and dissolve in a mixture of water and methanol (1:1) to make exactly 20 mL. Pipet 5 mL of this solution, add exactly 5 mL of the internal standard solution, then add a mixture of water and methanol (1:1) to make 50 mL, and use this solution as the standard solution. Perform the test with 10 μ L each of the sample solution and standard solution as directed under Liquid Chromatography <2.01> according to the following conditions, and calculate the ratios, Q_T and Q_S , of the peak area of atorvastatin to that of the internal standard.

$$\begin{aligned} &\text{Amount (mg) of atorvastatin calcium hydrate} \\ &(\text{C}_{66}\text{H}_{68}\text{CaF}_2\text{N}_4\text{O}_{10}\cdot 3\text{H}_2\text{O}) \\ &= M_S \times Q_T/Q_S \times V/200 \times 1.047 \end{aligned}$$

M_S : Amount (mg) of Atorvastatin Calcium RS taken, calculated on the anhydrous basis

Internal standard solution—A solution of 1,3-dinitrobenzene in methanol (1 in 2500).

Operating conditions—

Proceed as directed in the operating conditions in the Assay.

System suitability—

System performance: When the procedure is run with 10 μ L of the standard solution under the above operating conditions, the internal standard and atorvastatin are eluted in this order with the resolution between these peaks being not less than 10.

System repeatability: When the test is repeated 6 times with 10 μ L of the standard solution under the above operating conditions, the relative standard deviation of the ratio of the peak area of atorvastatin to that of the internal standard is not more than 1.0%.

Dissolution <6.10> When the test is performed at 75 revolutions per minute according to the Paddle method, using 900 mL of water as the dissolution medium, the dissolution rate in 15 minutes of Atorvastatin Calcium Tablets is not less than 80%.

Start the test with 1 tablet of Atorvastatin Calcium Tablets, withdraw not less than 20 mL of the medium at the specified minute after starting the test, and filter through a membrane filter with a pore size not exceeding 0.45 μ m. Discard not less than 10 mL of the first filtrate, pipet V mL of the subsequent filtrate, add water to make exactly V' mL so that each mL contains about 6 μ g of atorvastatin calcium hydrate (C₆₆H₆₈CaF₂N₄O₁₀·3H₂O), and use this solution as the sample solution. Separately, weigh accurately about 60 mg of Atorvastatin Calcium RS (separately determine the water <2.48> in the same manner as Atorvastatin Calcium Hydrate), and dissolve in a mixture of water and methanol (1:1) to make exactly 100 mL. Pipet 5 mL of this solution, add

water to make exactly 50 mL. Pipet 5 mL of this solution, add water to make exactly 50 mL, and use this solution as the standard solution. Perform the test with exactly 50 μ L each of the sample solution and standard solution as directed under Liquid Chromatography <2.01>, and determine the peak areas, A_T and A_S , of atorvastatin in each solution.

Dissolution rate (%) with respect to the labeled amount of atorvastatin calcium hydrate ($C_{66}H_{68}CaF_2N_4O_{10} \cdot 3H_2O$)

$$= M_S \times A_T / A_S \times V' / V \times 1 / C \times 9 \times 1.047$$

M_S : Amount (mg) of Atorvastatin Calcium RS taken, calculated on the anhydrous basis

C : Labeled amount (mg) of atorvastatin calcium hydrate ($C_{66}H_{68}CaF_2N_4O_{10} \cdot 3H_2O$) in 1 tablet

Operating conditions—

Proceed as directed in the operating conditions in the Assay.

System suitability—

System performance: When the procedure is run with 50 μ L of the standard solution under the above operating conditions, the number of theoretical plates and the symmetry factor of the peak of atorvastatin are not less than 6000 and not more than 2.0, respectively.

System repeatability: When the test is repeated 6 times with 50 μ L of the standard solution under the above operating conditions, the relative standard deviation of the peak area of atorvastatin is not more than 2.0%.

Assay To 20 Atorvastatin Calcium Tablets add 3V/5 mL of a mixture of water and methanol (1:1), and disintegrate the tablet by shaking. Add exactly V/10 mL of the internal standard solution, add a mixture of water and methanol (1:1) to make V mL so that each mL contains about 2 mg of atorvastatin calcium hydrate ($C_{66}H_{68}CaF_2N_4O_{10} \cdot 3H_2O$), and centrifuge. To 2.5 mL of the supernatant liquid add a mixture of water and methanol (1:1) to make 50 mL, and use this solution as the sample solution. Separately, weigh accurately about 44 mg of Atorvastatin Calcium RS (separately determine the water <2.48> in the same manner as Atorvastatin Calcium Hydrate), add exactly 2 mL of the internal standard solution, and add a mixture of water and methanol (1:1) to make 20 mL. Pipet 2.5 mL of this solution, add a mixture of water and methanol (1:1) to make 50 mL, and use this solution as the standard solution. Perform the test with 10 μ L each of the sample solution and standard solution as directed under Liquid Chromatography <2.01> according to the following conditions, and calculate the ratios, Q_T and Q_S , of the peak area of atorvastatin to that of the internal standard.

Amount (mg) of atorvastatin calcium hydrate ($C_{66}H_{68}CaF_2N_4O_{10} \cdot 3H_2O$) in 1 tablet of Atorvastatin Calcium Tablets

$$= M_S \times Q_T / Q_S \times V / 400 \times 1.047$$

M_S : Amount (mg) of Atorvastatin Calcium RS taken, calculated on the anhydrous basis

Internal standard solution—A solution of 1,3-dinitrobenzene in methanol (1 in 125).

Operating conditions—

Detector: An ultraviolet absorption photometer (wavelength: 244 nm).

Column: A stainless steel column 4.6 mm in inside diameter and 25 cm in length, packed with octadecylsilanized silica gel for liquid chromatography (5 μ m in particle diameter).

Column temperature: A constant temperature of about 30°C.

Mobile phase: Dissolve 10.5 g of citric acid monohydrate in 900 mL of water, adjust to pH 4.0 with ammonia solution (28), and add water to make 1000 mL. To 530 mL of this solution add 270 mL of acetonitrile and 200 mL of tetrahydrofuran.

Flow rate: Adjust so that the retention time of atorvastatin is about 9 minutes.

System suitability—

System performance: When the procedure is run with 10 μ L of the standard solution under the above operating conditions, the internal standard and atorvastatin are eluted in this order with the resolution between these peaks being not less than 10.

System repeatability: When the test is repeated 6 times with 10 μ L of the standard solution under the above operating conditions, the relative standard deviation of the ratio of the peak area of atorvastatin to that of the internal standard is not more than 1.0%.

Containers and storage Containers—Tight containers.

Atropine Sulfate Hydrate

アトロピン硫酸塩水和物

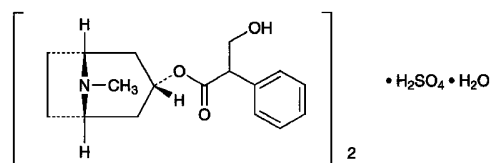

($C_{17}H_{23}NO_3$)₂·H₂SO₄·H₂O: 694.83

(1*R*,3*r*,5*S*)-8-Methyl-8-azabicyclo[3.2.1]oct-3-yl [(2*RS*)-3-hydroxy-2-phenyl]propanoate hemisulfate hemihydrate [5908-99-6]

Atropine Sulfate Hydrate, when dried, contains not less than 98.0% of atropine sulfate [($C_{17}H_{23}NO_3$)₂·H₂SO₄: 676.82].

Description Atropine Sulfate Hydrate occurs as colorless crystals or a white crystalline powder. It is odorless.

It is very soluble in water and in acetic acid (100), freely soluble in ethanol (95), and practically insoluble in diethyl ether.

Melting point: 188 – 194°C (with decomposition). Introduce a capillary tube charged with dried sample into a bath previously heated to 180°C, and continue to heat at a rate of rise of about 3°C per minute.

It is affected by light.

Identification (1) To 1 mg of Atropine Sulfate Hydrate add 3 drops of fuming nitric acid, and evaporate the mixture on a water bath to dryness. Dissolve the residue in 1 mL of *N,N*-dimethylformamide, and add 5 to 6 drops of tetraethylammonium hydroxide TS: a red-purple color develops.

(2) To 2 mL of a solution of Atropine Sulfate Hydrate (1 in 50) add 4 to 5 drops of hydrogen tetrachloroaurate (III) TS: a lusterless, yellow-white precipitate is formed.

(3) To 5 mL of a solution of Atropine Sulfate Hydrate (1 in 25) add 2 mL of ammonia TS, and allow to stand for 2 to 3 minutes. Collect the precipitate, wash with water, and dry in a desiccator (in vacuum, silica gel) for 4 hours: it melts <2.60> between 115°C and 118°C.

(4) A solution of Atropine Sulfate Hydrate (1 in 20) responds to Qualitative Tests <1.09> for sulfate.

Purity (1) Clarity and color of solution —Dissolve 0.5 g

of Atropine Sulfate Hydrate in 10 mL of water: the solution is clear and colorless.

(2) Acidity—Dissolve 1.0 g of Atropine Sulfate Hydrate in 20 mL of water, and add 0.30 mL of 0.02 mol/L sodium hydroxide VS and 1 drop of methyl red-methylene blue TS: a green color develops.

(3) Related substances—Dissolve 0.25 g of Atropine Sulfate Hydrate in 1 mL of diluted hydrochloric acid (1 in 10), add water to make 15 mL, and use this solution as the sample solution.

(i) To 5 mL of the sample solution add 2 to 3 drops of hydrogen hexachloroplatinate (IV) TS: no precipitate is formed.

(ii) To 5 mL of the sample solution add 2 mL of ammonia TS, and shake vigorously: the turbidity of the solution is not greater than that of the following control solution.

Control solution: To 0.30 mL of 0.01 mol/L hydrochloric acid VS add 6 mL of dilute nitric acid and water to make 50 mL. To this solution add 1 mL of silver nitrate TS, and allow 7 mL of the mixture to stand for 5 minutes.

(4) Hyoscyamine—Weigh accurately about 1 g of Atropine Sulfate Hydrate, previously dried, and dissolve in water to make exactly 10 mL: the specific optical rotation $[\alpha]_D^{20}$ <2.49> of this solution in a 100-mm cell is between -0.60° and $+0.10^\circ$.

(5) Readily carbonizable substances <1.15>—Take 0.20 g of Atropine Sulfate Hydrate, and perform the test: the solution has no more color than Matching Fluid A.

Loss on drying <2.41> Not more than 4.0% (0.5 g, in vacuum, phosphorus (V) oxide, 110°C , 4 hours).

Residue on ignition <2.44> Not more than 0.1% (0.5 g).

Assay Dissolve about 0.25 g of Atropine Sulfate Hydrate, previously dried and accurately weighed, in 30 mL of acetic acid (100). If necessary, dissolve it by warming, and cool. Titrate <2.50> with 0.05 mol/L perchloric acid VS until the color of the solution changes from purple through blue to blue-green (indicator: 3 drops of crystal violet TS). Perform a blank determination in the same manner, and make any necessary correction.

$$\begin{aligned} \text{Each mL of 0.05 mol/L perchloric acid VS} \\ = 33.84 \text{ mg of } (\text{C}_{17}\text{H}_{23}\text{NO}_3)_2 \cdot \text{H}_2\text{SO}_4 \end{aligned}$$

Containers and storage Containers—Tight containers. Storage—Light-resistant.

Atropine Sulfate Injection

アトロピン硫酸塩注射液

Atropine Sulfate Injection is an aqueous injection.

It contains not less than 93.0% and not more than 107.0% of the labeled amount of atropine sulfate hydrate $[(\text{C}_{17}\text{H}_{23}\text{NO}_3)_2 \cdot \text{H}_2\text{SO}_4 \cdot \text{H}_2\text{O}: 694.83]$.

Method of preparation Prepare as directed under Injections, with Atropine Sulfate Hydrate.

Description Atropine Sulfate Injection is a clear, colorless liquid.

pH: 4.0 – 6.0

Identification (1) Evaporate a volume of Atropine Sulfate Injection, equivalent to 1 mg of Atropine Sulfate Hydrate, on a water bath to dryness. Proceed with the residue as directed in the Identification (1) under Atropine Sulfate

Hydrate.

(2) Evaporate an exactly measured volume of Atropine Sulfate Injection, equivalent to 5 mg of Atropine Sulfate Hydrate, on a water bath to dryness. After cooling, dissolve the residue in 1 mL of ethanol (95), and use this solution as the sample solution. If insoluble substance remains, crush it, allow to stand, and use the supernatant liquid as the sample solution. Separately, dissolve 10 mg of Atropine Sulfate RS in 2 mL of ethanol (95), and use this solution as the standard solution. Perform the test with these solutions as directed under Thin-layer Chromatography <2.03>. Spot $5 \mu\text{L}$ each of the sample solution and standard solution on a plate of silica gel for thin-layer chromatography. Develop the plate with a mixture of acetone, water and ammonia water (28) (90:7:3) to a distance of about 10 cm, and dry the plate at 80°C for 10 minutes. After cooling, spray evenly Dragendorff's TS for spraying on the plate: the spots obtained from the sample solution and the standard solution show an orange color and the same Rf value.

(3) Atropine Sulfate Injection responds to Qualitative Tests <1.09> for sulfate.

Bacterial endotoxins <4.01> Less than 75 EU/mg.

Extractable volume <6.05> It meets the requirements.

Foreign insoluble matter <6.06> Perform the test according to Method 1: it meets the requirement.

Insoluble particulate matter <6.07> It meets the requirement.

Sterility <4.06> Perform the test: it meets the requirement.

Assay To an exactly measured volume of Atropine Sulfate Injection, equivalent to about 5 mg of atropine sulfate hydrate $[(\text{C}_{17}\text{H}_{23}\text{NO}_3)_2 \cdot \text{H}_2\text{SO}_4 \cdot \text{H}_2\text{O}]$, add exactly 3 mL of the internal standard solution and water to make 50 mL, and use this solution as the sample solution. Separately, weigh accurately about 25 mg of Atropine Sulfate RS (separately determine the loss on drying <2.41> under the same conditions as Atropine Sulfate Hydrate), and dissolve in water to make exactly 50 mL. Pipet 10 mL of this solution, add exactly 3 mL of the internal standard solution and water to make 50 mL, and use this solution as the standard solution. Perform the test with $20 \mu\text{L}$ each of the sample solution and standard solution as directed under Liquid Chromatography <2.01> according to the following conditions, and calculate the ratios, Q_T and Q_S , of the peak area of atropine to that of the internal standard.

$$\begin{aligned} \text{Amount (mg) of atropine sulfate hydrate} \\ [(\text{C}_{17}\text{H}_{23}\text{NO}_3)_2 \cdot \text{H}_2\text{SO}_4 \cdot \text{H}_2\text{O}] \\ = M_S \times Q_T / Q_S \times 1/5 \times 1.027 \end{aligned}$$

M_S : Amount (mg) of Atropine Sulfate RS taken, calculated based on the dried basis

Internal standard solution—A solution of etilefrine hydrochloride (1 in 1000).

Operating conditions—

Detector: An ultraviolet absorption photometer (wavelength: 210 nm).

Column: A stainless steel column 4.6 mm in inside diameter and 15 cm in length, packed with octadecylsilanized silica gel for liquid chromatography ($5 \mu\text{m}$ in particle diameter).

Column temperature: A constant temperature of about 40°C .

Mobile phase: To 0.4 g of sodium lauryl sulfate add 500 mL of diluted phosphoric acid (1 in 1000) to dissolve, and adjust the pH to 3.0 with sodium hydroxide TS. To 240 mL

of this solution add 70 mL of tetrahydrofuran, and mix.

Flow rate: Adjust so that the retention time of atropine is about 16 minutes.

System suitability—

System performance: When the procedure is run with 20 μL of the standard solution under the above operating conditions, the internal standard and atropine are eluted in this order with the resolution between these peaks being not less than 3.

System repeatability: When the test is repeated 6 times with 20 μL of the standard solution under the above operating conditions, the relative standard deviation of the ratio of the peak area of atropine to that of the internal standard is not more than 1.5%.

Containers and storage Containers—Hermetic containers.

Storage—Light-resistant.

Auranofin

オーラノフィン

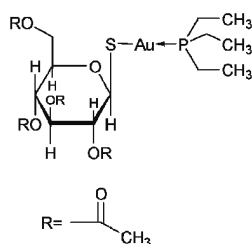

$\text{C}_{20}\text{H}_{34}\text{AuO}_9\text{PS}$: 678.48

(2,3,4,6-Tetra-*O*-acetyl-1-thio- β -D-glucopyranosato)(triethylphosphine)gold
[34031-32-8]

Auranofin, when dried, contains not less than 98.0% and not more than 102.0% of auranofin ($\text{C}_{20}\text{H}_{34}\text{AuO}_9\text{PS}$).

Description Auranofin occurs as a white crystalline powder.

It is very soluble in chloroform, freely soluble in methanol, sparingly soluble in ethanol (99.5), and practically insoluble in water.

It shows crystal polymorphism.

Identification (1) To 50 mg of Auranofin add 3 mL of water, 3 mL of nitric acid and 3 mL of sulfuric acid, shake, and allow to stand: golden colored suspended matters are produced.

(2) Determine the infrared absorption spectrum of Auranofin as directed in the paste method under Infrared Spectrophotometry <2.25>, and compare the spectrum with the Reference Spectrum or the spectrum of Auranofin RS: both spectra exhibit similar intensities of absorption at the same wave numbers.

(3) Prepare the test solution with 1 mg of Auranofin as directed under Oxygen Flask Combustion Method <1.06>, using 10 mL of water as the absorbing liquid. Wash out the test solution into a Nessler tube with water to make 30 mL. Add 10 mL of dilute sulfuric acid, 3 mL of hexaammonium heptamolybdate-sulfuric acid TS and 0.1 mL of tin (II) chloride TS, shake, and allow to stand for 10 to 15 minutes: a blue color is developed.

Optical rotation <2.49> $[\alpha]_D^{20}$: $-54.0 - -62.0^\circ$ (after drying, 0.2 g, methanol, 20 mL, 100 mm).

Melting point <2.60> 113 – 116°C

Purity (1) Chloride <1.03>—Put 0.5 g of Auranofin in a porcelain crucible, add 0.25 g of anhydrous sodium carbonate, mix well, and ignite until the carbonized substance is disappeared. After cooling, add 20 mL of water, heat, and filter after cooling. Wash the residue with 20 mL of water, combine the filtrate and the washings, neutralize with dilute nitric acid, then add 6 mL of dilute nitric acid and water to make 50 mL. Perform the test using this solution as the test solution. Prepare the control solution as follows: Dissolve 0.25 g of anhydrous sodium carbonate in 20 mL of water, neutralize with dilute nitric acid, add 0.50 mL of 0.01 mol/L hydrochloric acid, 6 mL of dilute nitric acid, and water to make 50 mL (not more than 0.036%).

(2) Heavy metals <1.07>—Proceed with 1.0 g of Auranofin according to Method 2, and perform the test. Prepare the control solution with 2.0 mL of Standard Lead Solution (not more than 20 ppm).

(3) Arsenic <1.11>—Put 0.5 g of Auranofin in a Kjeldahl flask, add cautiously 2 mL of sulfuric acid and 5 mL of nitric acid, and heat until the solution becomes almost colorless. After cooling, add 15 mL of a saturated solution of ammonium oxalate monohydrate, heat until white fumes are evolved, and concentrate to 1 to 2 mL. Then, add 3 mL of water and 1 drop of methyl orange TS, neutralize with ammonia solution (28), filter, and perform the test using the filtrate as the test solution: the color is not darker than that of the following control solution.

Control solution: Heat a mixture of 2 mL of sulfuric acid and 5 mL of nitric acid until white fumes are no longer evolved. After cooling, add 15 mL of a saturated solution of ammonium oxalate monohydrate, heat until white fumes are evolved, and concentrate to 1 to 2 mL. Add 3 mL of water and 1 drop of methyl orange TS, neutralize with ammonia solution (28), and filter. To the filtrate add 2.0 mL of Standard Arsenic Solution, then proceed in the same manner as for the test solution (not more than 4 ppm).

(4) Related substances—Dissolve 50 mg of Auranofin in 5 mL of chloroform, and use this solution as the sample solution. Pipet 1 mL of the sample solution, and add chloroform to make exactly 100 mL. To exactly 3 mL of this solution add chloroform to make exactly 10 mL, and use this solution as the standard solution. Perform the test with these solutions as directed under Thin-layer Chromatography <2.03>. Spot 10 μL each of the sample solution and standard solution on a plate of silica gel for thin-layer chromatography. Develop the plate with a mixture of chloroform and acetone (4:1) to a distance of about 10 cm, and air-dry the plate. Dry the plate, furthermore, at 80°C for 30 minutes. After cooling, allow the plate to stand in a iodine vapor for 30 minutes: the spots other than the principal spot obtained from the sample solution are not more intense than the spot from the standard solution.

Loss on drying <2.41> Not more than 0.5% (1 g, 105°C, 3 hours).

Assay Weigh accurately about 20 mg each of Auranofin and Auranofin RS, both previously dried, dissolve each in 10 mL of a mixture of water and acetonitrile (1:1), and add exactly 5 mL each of the internal standard solution. Then add a mixture of water and acetonitrile (1:1) to make 100 mL, and use these solutions as the sample solution and the standard solution, respectively. Perform the test with 10 μL each of the sample solution and standard solution as directed under Liquid Chromatography <2.01> according to the following conditions, and calculate the ratios, Q_T and Q_S , of

the peak area of auranofin to that of the internal standard.

$$\begin{aligned} \text{Amount (mg) of auranofin (C}_{20}\text{H}_{34}\text{AuO}_9\text{PS)} \\ = M_S \times Q_T/Q_S \end{aligned}$$

M_S : Amount (mg) of Auranofin RS taken

Internal standard solution—A solution of butyl parahydroxybenzoate in a mixture of water and acetonitrile (1:1) (3 in 1250).

Operating conditions—

Detector: An ultraviolet absorption photometer (wavelength: 230 nm).

Column: A stainless steel column 4 mm in inside diameter and 15 cm in length, packed with octadecylsilanized silica gel for liquid chromatography (5 μm in particle diameter).

Column temperature: A constant temperature of about 25°C.

Mobile phase: A mixture of sodium dihydrogen phosphate dihydrate solution (1 in 100), tetrahydrofuran and acetonitrile (12:5:3).

Flow rate: Adjust so that the retention time of auranofin is about 6 minutes.

System suitability—

System performance: When the procedure is run with 10 μL of the standard solution under the above operating conditions, auranofin and the internal standard are eluted in this order with the resolution between these peaks being not less than 9.

System repeatability: When the test is repeated 6 times with 10 μL of the standard solution under the above operating conditions, the relative standard deviation of the ratio of the peak area of auranofin to that of the internal standard is not more than 1.0%.

Containers and storage Containers—Tight containers.

Auranofin Tablets

オーラノフィン錠

Auranofin Tablets contain not less than 93.0% and not more than 107.0% of the labeled amount of auranofin (C₂₀H₃₄AuO₉PS: 678.48).

Method of preparation Prepare as directed under Tablets, with Auranofin.

Identification Put an amount of powdered Auranofin Tablets, equivalent to 11 mg of Auranofin, in a porcelain crucible, and heat weakly to carbonize. After cooling, add 2 mL of nitric acid and 5 drops of sulfuric acid, heat cautiously at first then incinerate by ignition. After cooling, add 4 mL of aqua regia to the residue, dissolve by warming, and add 16 mL of water. To 5 mL of this solution add 0.5 mL of tin (II) chloride TS: a purple to red-brown color is developed.

Uniformity of dosage units <6.02> Perform the test according to the following method: it meets the requirement of the Content uniformity test.

To 1 tablet of Auranofin Tablets add 2 mL of water, disintegrate the tablet by sonicating, add exactly 2 mL of the internal standard solution for every 3 mg of auranofin (C₂₀H₃₄AuO₉PS), and add 2 mL of a mixture of water and acetonitrile (1:1). Shake for 15 minutes, then add a mixture of water and acetonitrile (1:1) to make V mL so that each mL contains 0.3 mg of auranofin (C₂₀H₃₄AuO₉PS), centrifuge, and use the supernatant liquid as the sample solution.

Then, proceed as directed in the Assay.

$$\begin{aligned} \text{Amount (mg) of auranofin (C}_{20}\text{H}_{34}\text{AuO}_9\text{PS)} \\ = M_S \times Q_T/Q_S \times V/100 \end{aligned}$$

M_S : Amount (mg) of Auranofin RS taken

Internal standard solution—A solution of butyl parahydroxybenzoate in acetonitrile (9 in 10,000).

Dissolution <6.10> When the test is performed at 50 revolutions per minute according to the Paddle method, using 900 mL of water as the dissolution medium, the dissolution rate in 15 minutes of Auranofin Tablets is not less than 85%.

Start the test with 1 tablet of Auranofin Tablets, withdraw not less than 20 mL of the medium at the specified minute after starting the test, and filter through a membrane filter with a pore size not exceeding 0.45 μm . Discard not less than 10 mL of the first filtrate, pipet V mL of the subsequent filtrate, add water to make exactly V' mL so that each mL contains about 3.3 μg of auranofin (C₂₀H₃₄AuO₉PS), and use this solution as the sample solution. Separately, weigh accurately about 30 mg of Auranofin RS, previously dried at 105°C for 3 hours, and dissolve in acetonitrile to make exactly 50 mL. Pipet 5 mL of this solution, and add water to make exactly 100 mL. Pipet 10 mL of this solution, add water to make exactly 100 mL, and use this solution as the standard solution. Perform the test with exactly 50 μL each of the sample solution and standard solution as directed under Liquid Chromatography <2.01> under the following conditions, and determine the peak areas, A_T and A_S , of auranofin in each solution.

Dissolution rate (%) with respect to the labeled amount of auranofin (C₂₀H₃₄AuO₉PS)

$$= M_S \times A_T/A_S \times V'/V \times 1/C \times 9$$

M_S : Amount (mg) of Auranofin RS taken

C : Labeled amount (mg) of auranofin (C₂₀H₃₄AuO₉PS) in 1 tablet

Operating conditions—

Proceed as directed in the operating conditions in the Assay under Auranofin.

System suitability—

System performance: When the procedure is run with 50 μL of the standard solution under the above operating conditions, the number of theoretical plates and the symmetry factor of the peak of auranofin are not less than 5000 and not more than 2.0, respectively.

System repeatability: When the test is repeated 6 times with 50 μL of the standard solution under the above operating conditions, the relative standard deviation of the peak area of auranofin is not more than 1.0%.

Assay Accurately weigh the mass of not less than 20 Auranofin Tablets, and powder them. Weigh accurately a portion of the powder, equivalent to about 60 mg of auranofin (C₂₀H₃₄AuO₉PS), add 40 mL of water, disperse the particles with the aid of ultrasonic waves, then add exactly 40 mL of the internal standard solution, add 40 mL of a mixture of water and acetonitrile (1:1), and shake for 15 minutes. To this solution add a mixture of water and acetonitrile (1:1) to make 200 mL, centrifuge, and use the supernatant liquid as the sample solution. Separately, weigh accurately about 30 mg of Auranofin RS, previously dried at 105°C for 3 hours, dissolve in 60 mL of a mixture of water and acetonitrile (1:1), add exactly 20 mL of the internal standard solution, then add water to make 100 mL, and use this solution as the standard solution. Perform the test with 10 μL each of the sample solution and standard solution as

directed under Liquid Chromatography <2.01> according to the following conditions, and calculate the ratios, Q_T and Q_S , of the peak area of auranofin to that of the internal standard.

$$\begin{aligned} \text{Amount (mg) of auranofin (C}_{20}\text{H}_{34}\text{AuO}_9\text{PS)} \\ = M_S \times Q_T / Q_S \times 2 \end{aligned}$$

M_S : Amount (mg) of Auranofin RS taken

Internal standard solution—A solution of butyl parahydroxybenzoate in acetonitrile (9 in 10,000).

Operating conditions—

Proceed as directed in the operating conditions in the Assay under Auranofin.

System suitability—

System performance: When the procedure is run with 10 μL of the standard solution under the above operating conditions, auranofin and the internal standard are eluted in this order with the resolution between these peaks being not less than 9.

System repeatability: When the test is repeated 6 times with 10 μL of the standard solution under the above operating conditions, the relative standard deviation of the ratio of the peak area of auranofin to that of the internal standard is not more than 1.0%.

Containers and storage Containers—Tight containers.

Azathioprine

アザチオプリン

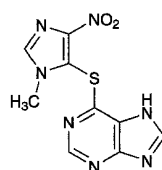

$\text{C}_9\text{H}_7\text{N}_7\text{O}_2\text{S}$: 277.26

6-(1-Methyl-4-nitro-1H-imidazol-5-ylthio)purine
[446-86-6]

Azathioprine, when dried, contains not less than 98.5% of azathioprine ($\text{C}_9\text{H}_7\text{N}_7\text{O}_2\text{S}$).

Description Azathioprine is light yellow, crystals or crystalline powder. It is odorless.

It is sparingly soluble in *N,N*-dimethylformamide and in pyridine, very slightly soluble in water and in ethanol (99.5), and practically insoluble in chloroform and in diethyl ether.

It dissolves in sodium hydroxide TS and in ammonia TS.

It is gradually colored by light.

Melting point: about 240°C (with decomposition).

Identification (1) Dissolve 0.01 g of Azathioprine in 50 mL of water by warming. To 5 mL of this solution add 1 mL of dilute hydrochloric acid and 0.01 g of zinc powder, and allow to stand for 5 minutes: a yellow color is produced. Filter this solution: the filtrate responds to Qualitative Tests <1.09> for primary aromatic amines, and a red color is produced.

(2) Dissolve 0.01 g of Azathioprine in 50 mL of water by warming. To 1 mL of this solution add 0.5 mL of phosphotungstic acid TS and 0.5 mL of dilute hydrochloric acid: a white precipitate is formed.

(3) Prepare the test solution by proceeding with 0.03 g of Azathioprine according to Oxygen Flask Combustion

Method <1.06>, using 20 mL of water as the absorbing liquid: the test solution responds to Qualitative Tests <1.09> (1) for sulfate.

(4) Dissolve 0.01 g of Azathioprine in 2 mol/L hydrochloric acid TS to make 100 mL. Dilute 5 mL of the solution with water to make 50 mL. Determine the absorption spectrum of the solution as directed under Ultraviolet-visible Spectrophotometry <2.24>, and compare the spectrum with the Reference Spectrum of a solution of Azathioprine RS prepared in the same manner as the sample solution: both spectra exhibit similar intensities of absorption at the same wavelengths.

Purity (1) Clarity and color of solution—Dissolve 0.5 g of Azathioprine in 50 mL of *N,N*-dimethylformamide: the solution is clear and shows a light yellow color.

(2) Acidity or alkalinity—Add 100 mL of water to 2.0 g of Azathioprine, shake well for 15 minutes, centrifuge for 5 minutes at 10,000 revolutions per minute, and filter. Discard the first 20 mL of the filtrate, add 2 drops of methyl red TS to 40 mL of the subsequent filtrate, and use this solution as the sample solution.

(i) Add 0.10 mL of 0.02 mol/L hydrochloric acid VS to 20 mL of the sample solution: a red color develops.

(ii) Add 0.10 mL of 0.02 mol/L sodium hydroxide VS to 20 mL of the sample solution: a yellow color develops.

(3) Sulfate <1.14>—To 25 mL of the filtrate obtained in (2) add 1 mL of dilute hydrochloric acid and water to make 50 mL, and perform the test using this solution as the test solution. Prepare the control solution with 0.40 mL of 0.005 mol/L sulfuric acid VS (not more than 0.038%).

(4) Heavy metals <1.07>—Proceed with 2.0 g of Azathioprine according to Method 2, and perform the test. Prepare the control solution with 2.0 mL of Standard Lead Solution (not more than 10 ppm).

(5) Arsenic <1.11>—Prepare the test solution with 1.0 g of Azathioprine, according to Method 3, and perform the test (not more than 2 ppm).

(6) Related substances—Dissolve 10 mg of Azathioprine in 80 mL of the mobile phase by warming, cool, add the mobile phase to make 100 mL, and use this solution as the sample solution. Pipet 1 mL of the sample solution, add water to make exactly 100 mL, and use this solution as the standard solution. Perform the test with exactly 20 μL each of the sample solution and standard solution as directed under Liquid Chromatography <2.01> according to the following conditions. Determine each peak area by the automatic integration method: the total area of the peaks other than azathioprine obtained from the sample solution is not larger than 1/2 times the peak area of azathioprine from the standard solution.

Operating conditions—

Detector: An ultraviolet absorption photometer (wavelength: 296 nm).

Column: A stainless steel column 4.6 mm in inside diameter and 15 cm in length, packed with octadecylsilanized silica gel for liquid chromatography (5 μm in particle diameter).

Column temperature: A constant temperature of about 40°C.

Mobile phase: Adjust to pH 2.5 of a solution of 0.05 mol/L potassium dihydrogenphosphate TS (1 in 2) with diluted phosphoric acid (3 in 2000). To 800 mL of this solution add 200 mL of methanol.

Flow rate: Adjust so that the retention time of azathioprine is about 8 minutes.

Time span of measurement: About three times as long as the retention time of azathioprine, beginning after the sol-

vent peak.

System suitability—

Test for required detectability: To exactly 5 mL of the standard solution add water to make exactly 50 mL. Confirm that the peak area of azathioprine obtained with 20 μ L of this solution is equivalent to 8 to 12% of that with 20 μ L of the standard solution.

System performance: Dissolve 10 mg of Azathioprine in 80 mL of water by warming, cool, and add water to make 100 mL. To 2 mL of this solution add 2 mL of a solution, separately prepared by dissolving 0.06 g of benzoic acid in 3 mL of methanol and diluting with water to make 10 mL, and add the mobile phase to make 25 mL. When the procedure is run with 20 μ L of this solution under the above operating conditions, azathioprine and benzoic acid are eluted in this order with the resolution between these peaks being not less than 9.

System repeatability: When the test is repeated 6 times with 20 μ L of the standard solution under the above operating conditions, the relative standard deviation of the peak areas of azathioprine is not more than 2.0%.

Loss on drying <2.41> Not more than 0.5% (1 g, 105°C, 5 hours).

Residue on ignition <2.44> Not more than 0.1% (1 g).

Assay Weigh accurately about 0.5 g of Azathioprine, previously dried, add 80 mL of *N,N*-dimethylformamide, and warm to dissolve. After cooling, titrate <2.50> with 0.1 mol/L tetramethylammonium hydroxide VS until the color of the solution changes from yellow through yellow-green to blue-green (indicator: 1 mL of thymol blue-dimethylformamide TS). Perform a blank determination in the same manner, and make any necessary correction.

Each mL of 0.1 mol/L tetramethylammonium hydroxide VS = 27.73 mg of $C_9H_7N_7O_2S$

Containers and storage Containers—Well-closed containers.

Storage—Light-resistant.

Azathioprine Tablets

アザチオプリン錠

Azathioprine Tablets contain not less than 95.0% and not more than 105.0% of the labeled amount of azathioprine ($C_9H_7N_7O_2S$; 277.26).

Method of preparation Prepare as directed under Tablets, with Azathioprine.

Identification (1) Weigh a quantity of powdered Azathioprine Tablets, equivalent to 0.01 g of Azathioprine. Add 50 mL of water, shake well while warming, and filter. Proceed with 5 mL of the filtrate as directed in the Identification (1) under Azathioprine.

(2) Proceed with 1 mL of the filtrate obtained in (1) as directed in the Identification (2) under Azathioprine.

(3) Determine the absorption spectrum of the sample solution in the Assay as directed under Ultraviolet-visible Spectrophotometry <2.24>: it exhibits a maximum between 278 nm and 282 nm.

(4) Weigh a quantity of powdered Azathioprine Tablets, equivalent to 0.1 g of Azathioprine to the labeled amount. Add 10 mL of a solution of ammonia solution (28) in ethanol (95) (1 in 10), shake well, filter, and use the filtrate

as the sample solution. Separately, dissolve 0.1 g of Azathioprine RS in 10 mL of a solution of ammonia solution (28) in ethanol (95) (1 in 10), and use this solution as the standard solution. Perform the test with these solutions as directed under Thin-layer Chromatography <2.03>. Spot 5 μ L each of the sample solution and standard solution on a plate of silica gel with fluorescent indicator for thin-layer chromatography. Develop the plate with a mixture of ethanol (95), ethyl acetate, and ammonia solution (28) (5:5:1) to a distance of about 7 cm, and air-dry the plate. Examine under ultraviolet light (main wavelength: 254 nm): the spots obtained from the sample solution and the standard solution show the same *R_f* value.

Uniformity of dosage units <6.02> Perform the Mass variation test, or the Content uniformity test according to the following method: it meets the requirement.

To 1 tablet of Azathioprine Tablets add 1 mL of dimethylsulfoxide for ultraviolet-visible spectrophotometry per 5 mg of azathioprine ($C_9H_7N_7O_2S$), shake well, add 0.1 mol/L hydrochloric acid TS to make exactly *V* mL so that each mL contains about 0.2 mg of azathioprine ($C_9H_7N_7O_2S$), and filter. Discard the first 20 mL of the filtrate, pipet 3 mL of the subsequent filtrate, add 0.1 mol/L hydrochloric acid TS to make exactly 100 mL, and use this solution as the sample solution. Then, proceed as directed in the Assay.

$$\begin{aligned} &\text{Amount (mg) of azathioprine (C}_9\text{H}_7\text{N}_7\text{O}_2\text{S)} \\ &= M_S \times A_T/A_S \times V/500 \end{aligned}$$

M_S: Amount (mg) of Azathioprine RS taken

Dissolution <6.10> When the test is performed at 50 revolutions per minute according to the Paddle method, using 900 mL of water as the dissolution medium, the dissolution rate in 45 minutes of Azathioprine Tablets is not less than 80%.

Start the test with 1 tablet of Azathioprine Tablets, withdraw not less than 20 mL of the medium at the specified minute after starting the test, and filter through a membrane filter with a pore size not exceeding 0.8 μ m. Discard not less than 10 mL of the first filtrate, pipet *V* mL of the subsequent filtrate, add water to make exactly *V'* mL so that each mL contains about 11 μ g of azathioprine ($C_9H_7N_7O_2S$), and use this solution as the sample solution. Separately, weigh accurately about 10 mg of Azathioprine RS, previously dried at 105°C for 5 hours, and dissolve in water to make exactly 100 mL. Pipet 6 mL of this solution, add water to make exactly 50 mL, and use this solution as the standard solution. Determine the absorbances, *A_T* and *A_S*, at 280 nm of the sample solution and standard solution as directed under Ultraviolet-visible Spectrophotometry <2.24>.

$$\begin{aligned} &\text{Dissolution rate (\%)} \text{ with respect to the labeled amount} \\ &\text{of azathioprine (C}_9\text{H}_7\text{N}_7\text{O}_2\text{S)} \\ &= M_S \times A_T/A_S \times V'/V \times 1/C \times 108 \end{aligned}$$

M_S: Amount (mg) of Azathioprine RS taken

C: Labeled amount (mg) of azathioprine ($C_9H_7N_7O_2S$) in 1 tablet

Assay Weigh accurately and powder not less than 20 Azathioprine Tablets. Weigh accurately a portion of the powder, equivalent to about 0.1 g of azathioprine ($C_9H_7N_7O_2S$), add 20 mL of dimethylsulfoxide for ultraviolet-visible spectrophotometry, shake well, add 0.1 mol/L hydrochloric acid TS to make exactly 500 mL, and filter. Discard the first 20 mL of the filtrate, measure exactly 3 mL of the subsequent filtrate, add 0.1 mol/L hydrochloric acid TS to make exactly 100 mL, and use this solution as the sample solution. Separately, weigh accurately about 0.1 g of

Azathioprine RS, previously dried at 105°C for 5 hours, dissolve in 20 mL of dimethylsulfoxide for ultraviolet-visible spectrophotometry, and add 0.1 mol/L hydrochloric acid TS to make exactly 500 mL. Measure exactly 3 mL of this solution, add 0.1 mol/L hydrochloric acid TS to make exactly 100 mL, and use this solution as the standard solution. Determine the absorbances, A_T and A_S , of the sample solution and standard solution at 280 nm as directed under Ultraviolet-visible Spectrophotometry <2.24>.

$$\begin{aligned} \text{Amount (mg) of azathioprine (C}_9\text{H}_7\text{N}_7\text{O}_2\text{S)} \\ = M_S \times A_T/A_S \end{aligned}$$

M_S : Amount (mg) of Azathioprine RS taken

Containers and storage Containers—Tight containers.
Storage—Light-resistant.

Azelastine Hydrochloride

アゼラスチン塩酸塩

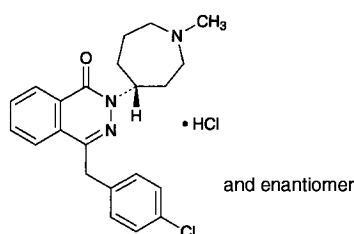

$C_{22}H_{24}ClN_3O \cdot HCl$: 418.36
4-[(4-Chlorophenyl)methyl]-2-[(*1RS*)-
(1-methylazepan-4-yl)]phthalazin-1(*2H*)-one
monohydrochloride
[79307-93-0]

Azelastine Hydrochloride, when dried, contains not less than 99.0% and not more than 101.0% of azelastine hydrochloride ($C_{22}H_{24}ClN_3O \cdot HCl$).

Description Azelastine Hydrochloride occurs as a white crystalline powder.

It is freely soluble in formic acid, and slightly soluble in water and in ethanol (99.5).

Melting point: about 225°C (with decomposition).

A solution of Azelastine Hydrochloride (1 in 200) shows no optical rotation.

Identification (1) Determine the absorption spectrum of a solution of Azelastine Hydrochloride (3 in 100,000) as directed under Ultraviolet-visible Spectrophotometry <2.24>, and compare the spectrum with the Reference Spectrum: both spectra exhibit similar intensities of absorption at the same wavelengths.

(2) Determine the infrared absorption spectrum of Azelastine Hydrochloride as directed in the potassium chloride disk method under Infrared Spectrophotometry <2.25>: both spectra exhibit similar intensities of absorption at the same wave numbers.

(3) To 10 mL of a saturated solution of Azelastine Hydrochloride add 1 mL of dilute nitric acid, and filter to separate formed crystals: the filtrate responds to Qualitative Tests <1.09> (2) for chloride.

Purity (1) Heavy metals <1.07>—Proceed with 1.0 g of Azelastine Hydrochloride according to Method 2, and perform the test. Prepare the control solution with 2.0 mL of Standard Lead Solution (not more than 20 ppm).

(2) Arsenic <1.11>—Prepare the test solution with 1.0 g of Azelastine Hydrochloride according to Method 3, and perform the test (not more than 2 ppm).

(3) Related substances—Dissolve 50 mg of Azelastine Hydrochloride in 100 mL of the mobile phase, and use this solution as the sample solution. Pipet 1 mL of the sample solution, add the mobile phase to make exactly 100 mL, and use this solution as the standard solution. Perform the test with exactly 20 μ L each of the sample solution and standard solution as directed under Liquid Chromatography <2.01> according to the following conditions. Determine each peak area of these solutions by the automatic integration method: each peak area other than azelastine obtained from the sample solution is not larger than 1/10 times the peak area of azelastine from the standard solution, and the total area of the peaks other than the peak of azelastine from the sample solution is not larger than 1/2 times the peak area of azelastine from the standard solution.

Operating conditions—

Detector: An ultraviolet absorption photometer (wavelength: 240 nm).

Column: A stainless steel column 4.6 mm in inside diameter and 15 cm in length, packed with octadecylsilanized silica gel for liquid chromatography (5 μ m in particle diameter).

Column temperature: A constant temperature of about 35°C.

Mobile phase: A mixture of water, acetonitrile and perchloric acid (660:340:1).

Flow rate: Adjust so that the retention time of azelastine is about 10 minutes.

Time span of measurement: About 2 times as long as the retention time of azelastine, beginning after the solvent peak.

System suitability—

Test for required detectability: Pipet 5 mL of the standard solution, and add the mobile phase to make exactly 50 mL. Confirm that the peak area of azelastine obtained with 20 μ L of this solution is equivalent to 7 to 13% of that with 20 μ L of the standard solution.

System performance: When the procedure is run with 20 μ L of the standard solution under the above operating conditions, the number of theoretical plates and the symmetry factor of the peak of azelastine is not less than 5000 and not more than 1.5, respectively.

System repeatability: When the test is repeated 6 times with 20 μ L of the standard solution under the above operating conditions, the relative standard deviation of the peak area of azelastine is not more than 1.0%.

Loss on drying <2.41> Not more than 1.0% (1 g, 105°C, 2 hours).

Residue on ignition <2.44> Not more than 0.1% (1 g).

Assay Weigh accurately about 0.6 g of previously dried Azelastine Hydrochloride, dissolve in 5 mL of formic acid, add 70 mL of acetic anhydride, and titrate <2.50> with 0.1 mol/L perchloric acid VS (potentiometric titration). Perform a blank determination in the same manner, and make any necessary correction.

$$\begin{aligned} \text{Each mL of 0.1 mol/L perchloric acid VS} \\ = 41.84 \text{ mg of } C_{22}H_{24}ClN_3O \cdot HCl \end{aligned}$$

Containers and storage Containers—Tight containers.
Storage—Light-resistant.

Azelastine Hydrochloride Granules

アゼラスチン塩酸塩顆粒

Azelastine Hydrochloride Granules contain not less than 93.0% and not more than 107.0% of the labeled amount of azelastine hydrochloride ($C_{22}H_{24}ClN_3O.HCl$; 418.36).

Method of preparation Prepare as directed under Granules, with Azelastine Hydrochloride.

Identification To a quantity of Azelastine Hydrochloride Granules, equivalent to 2 mg of Azelastine Hydrochloride, add 30 mL of 0.1 mol/L hydrochloric acid TS, and sonicate for 30 minutes. After cooling, add 0.1 mol/L hydrochloric acid TS to make 50 mL, and centrifuge. Determine the absorption spectrum of the supernatant liquid as directed under Ultraviolet-visible Spectrophotometry <2.24>: it exhibits a maximum between 283 nm and 287 nm.

Dissolution <6.10> When the test is performed at 50 revolutions per minute according to the Paddle method, using 900 mL of 0.05 mol/L acetic acid-sodium acetate buffer solution (pH 4.0) as the dissolution medium, the dissolution rate in 45 minutes of Azelastine Hydrochloride Granules is not less than 80%.

Start the test with accurately weighed amount of Azelastine Hydrochloride Granules, equivalent to about 1 mg of azelastine hydrochloride ($C_{22}H_{24}ClN_3O.HCl$), withdraw not less than 20 mL of the medium at the specified minute after starting the test, and filter through a membrane filter with a pore size not exceeding 0.5 μm . Discard not less than 10 mL of the first filtrate, and use the subsequent filtrate as the sample solution. Separately, weigh accurately about 50 mg of azelastine hydrochloride for assay, previously dried at 105°C for 2 hours, and dissolve in the dissolution medium to make exactly 250 mL. Pipet 1 mL of this solution, add the dissolution medium to make exactly 200 mL, and use this solution as the standard solution. Perform the test with exactly 50 μL each of the sample solution and standard solution as directed under Liquid Chromatography <2.01> according to the following conditions, and determine the peak areas, A_T and A_S , of azelastine in each solution.

Dissolution rate (%) with respect to the labeled amount of azelastine hydrochloride ($C_{22}H_{24}ClN_3O.HCl$)

$$= M_S/M_T \times A_T/A_S \times 1/C \times 9/5$$

M_S : Amount (mg) of azelastine hydrochloride for assay taken

M_T : Amount (g) of Azelastine Hydrochloride Granules taken

C : Labeled amount (mg) of azelastine hydrochloride ($C_{22}H_{24}ClN_3O.HCl$) in 1 g

Operating conditions—

Proceed as directed in the operating conditions in the Assay.

System suitability—

System performance: When the procedure is run with 50 μL of the standard solution under the above operating conditions, the number of theoretical plates and the symmetry factor of the peak of azelastine are not less than 2000 and not more than 1.5, respectively.

System repeatability: When the test is repeated 6 times with 50 μL of the standard solution under the above operating conditions, the relative standard deviation of the peak

area of azelastine is not more than 2.0%.

Assay Weigh accurately an amount of Azelastine Hydrochloride Granules, equivalent to about 2 mg of azelastine hydrochloride ($C_{22}H_{24}ClN_3O.HCl$), add 50 mL of 0.1 mol/L hydrochloric acid TS, sonicate for 20 minutes, add 40 mL of ethanol (99.5), add exactly 5 mL of the internal standard solution, and add ethanol (99.5) to make 100 mL. Centrifuge this solution, and use the supernatant liquid as the sample solution. Separately, weigh accurately about 50 mg of azelastine hydrochloride for assay, previously dried at 105°C for 2 hours, and dissolve in water to make exactly 50 mL. Pipet 10 mL of this solution, and add 0.1 mol/L hydrochloric acid TS to make exactly 50 mL. Pipet 10 mL of this solution, add 40 mL of 0.1 mol/L hydrochloric acid TS and 40 mL of ethanol (99.5), add exactly 5 mL of the internal standard solution, add ethanol (99.5) to make 100 mL, and use this solution as the standard solution. Perform the test with 20 μL each of the sample solution and standard solution as directed under Liquid Chromatography <2.01> according to the following conditions, and calculate the ratios, Q_T and Q_S , of the peak area of azelastine to that of the internal standard.

$$\begin{aligned} &\text{Amount (mg) of azelastine hydrochloride} \\ &(\text{C}_{22}\text{H}_{24}\text{ClN}_3\text{O.HCl}) \\ &= M_S \times Q_T/Q_S \times 1/25 \end{aligned}$$

M_S : Amount (mg) of azelastine hydrochloride for assay taken

Internal standard solution—Dissolve 0.2 g of 2-ethylhexyl parahydroxybenzoate in ethanol (99.5) to make 100 mL.

Operating conditions—

Detector: An ultraviolet absorption photometer (wavelength: 285 nm).

Column: A stainless steel column 4.6 mm in inside diameter and 15 cm in length, packed with octadecylsilanized silica gel for liquid chromatography (5 μm in particle diameter).

Column temperature: A constant temperature of about 40°C.

Mobile phase: A mixture of acetonitrile and a solution of sodium lauryl sulfate in diluted acetic acid (100) (1 in 250) (1 in 500) (11:9).

Flow rate: Adjust so that the retention time of azelastine is about 6 minutes.

System suitability—

System performance: When the procedure is run with 20 μL of the standard solution under the above operating conditions, azelastine and the internal standard are eluted in this order with the resolution between these peaks being not less than 2.0.

System repeatability: When the test is repeated 6 times with 20 μL of the standard solution under the above operating conditions, the relative standard deviation of the ratio of the peak area of azelastine to that of the internal standard is not more than 1.0%.

Containers and storage Containers—Tight containers.

Azelnidipine

アゼルニジピン

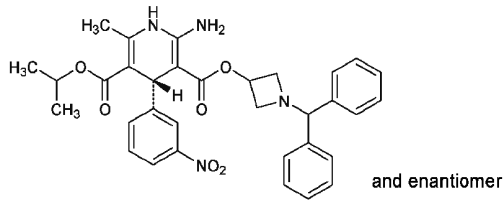

$C_{33}H_{34}N_4O_6$; 582.65

3-[1-(Diphenylmethyl)azetidino-3-yl] 5-(1-methylethyl)
(4*R*)-2-amino-6-methyl-4-(3-nitrophenyl)-1,4-dihydropyridine-
3,5-dicarboxylate
[123524-52-7]

Azelnidipine contains not less than 99.0% and not more than 101.0% of azelnidipine ($C_{33}H_{34}N_4O_6$), calculated on the dried basis.

Description Azelnidipine occurs as a light yellow to yellow, crystalline powder or powder containing masses.

It is freely soluble in ethanol (99.5) and in acetic acid (100), and practically insoluble in water.

A solution of Azelnidipine in ethanol (99.5) (1 in 100) shows no optical rotation.

Azelnidipine shows crystal polymorphism.

Identification (1) Determine the absorption spectrum of a solution of Azelnidipine in ethanol (99.5) (1 in 50,000) as directed under Ultraviolet-visible Spectrophotometry <2.24>, and compare the spectrum with the Reference Spectrum: both spectra exhibit similar intensities of absorption at the same wavelengths.

(2) Determine the infrared absorption spectrum of Azelnidipine as directed in the paste method under Infrared Spectrophotometry <2.25>, and compare the spectrum with the Reference Spectrum: both spectra exhibit similar intensities of absorption at the same wave numbers.

Purity (1) Heavy metals <1.07>—Proceed with 1.0 g of Azelnidipine according to Method 2, and perform the test. Prepare the control solution with 1.0 mL of Standard Lead Solution (not more than 10 ppm).

(2) Related substances—Dissolve 0.10 g of Azelnidipine in a mixture of acetonitrile and water (4:1) to make 100 mL, and use this solution as the sample solution. Pipet 2 mL of the sample solution, add a mixture of acetonitrile and water (4:1) to make exactly 200 mL, and use this solution as the standard solution. Perform the test with exactly 10 μ L each of the sample solution and standard solution as directed under Liquid Chromatography <2.01> according to the following conditions. Determine each peak area by the automatic integration method: the areas of the peak, having the relative retention time of about 0.50 and about 1.42 to azelnidipine, obtained from the sample solution are not larger than 1/5 times and 3/10 times the peak area of azelnidipine from the standard solution, respectively, the area of the peak other than azelnidipine and the peaks mentioned above from the sample solution is not larger than 1/10 times the peak area of azelnidipine from the standard solution, and the total area of the peaks other than azelnidipine from the sample solution is not larger than 7/10 times the peak area of azelnidipine from the standard solution.

Operating conditions—

Detector: An ultraviolet absorption photometer (wave-

length: 220 nm).

Column: A stainless steel column 4.6 mm in inside diameter and 25 cm in length, packed with octadecylsilanized silica gel for liquid chromatography (5 μ m in particle diameter).

Column temperature: A constant temperature of about 40°C.

Mobile phase: Dissolve 1.05 g of potassium dihydrogen phosphate in 350 mL of water, add 650 mL of a mixture of acetonitrile and methanol (7:3), and adjust to pH 5.5 with diluted phosphoric acid (1 in 10).

Flow rate: Adjust so that the retention time of azelnidipine is about 36 minutes.

Time span of measurement: About 2 times as long as the retention time of azelnidipine, beginning after the solvent peak.

System suitability—

Test for required detectability: To exactly 1 mL of the standard solution add a mixture of acetonitrile and water (4:1) to make exactly 20 mL. Confirm that the peak area of azelnidipine obtained with 10 μ L of this solution is equivalent to 3.5 to 6.5% of that with 10 μ L of the standard solution.

System performance: When the procedure is run with 10 μ L of the standard solution under the above operating conditions, the number of theoretical plates and the symmetry factor of the peak of azelnidipine are not less than 15,000 and 0.8 to 1.5, respectively.

System repeatability: When the test is repeated 6 times with 10 μ L of the standard solution under the above operating conditions, the relative standard deviation of the peak area of azelnidipine is not more than 1.0%.

Loss on drying <2.41> Not more than 0.5% (1 g, in vacuum, 70°C, 5 hours).

Residue on ignition <2.44> Not more than 0.1% (1 g).

Assay Weigh accurately about 0.4 g of Azelnidipine, dissolve in 50 mL of acetic acid (100), and titrate <2.50> with 0.1 mol/L perchloric acid VS (potentiometric titration). Perform a blank determination in the same manner, and make any necessary correction.

Each mL of 0.1 mol/L perchloric acid VS
= 29.13 mg of $C_{33}H_{34}N_4O_6$

Containers and storage Containers—Tight containers.

Azelnidipine Tablets

アゼルニジピン錠

Azelnidipine Tablets contain not less than 95.0% and not more than 105.0% of the labeled amount of azelnidipine ($C_{33}H_{34}N_4O_6$; 582.65).

Method of preparation Prepare as directed under Tablets, with Azelnidipine.

Identification Powder Azelnidipine Tablets. Weigh a portion of the powder, equivalent to 4 mg of Azelnidipine, add 150 mL of ethanol (99.5), sonicate for 15 minutes, then add ethanol (99.5) to make 200 mL. Centrifuge this solution, filter the supernatant liquid through a glass wool filter with a pore size not exceeding 0.7 μ m. Discard the first 10 mL of the filtrate, and use the subsequent filtrate as the sample solution. Determine the absorption spectrum of the sample solution as directed under Ultraviolet-visible Spectrophotometry <2.24>: it exhibits maxima between 253 nm and 257

nm and between 339 nm and 346 nm.

Purity Related substances—Conduct this procedure using light-resistant vessels. Powder Azelnidipine Tablets. Weigh a portion of the powder, equivalent to 10 mg of Azelnidipine, add 10 mL of a mixture of acetonitrile and water (4:1), agitate gently, then disperse to fine particles by sonicating for 15 minutes. Centrifuge this solution, and use the supernatant liquid as the sample solution. Pipet 2 mL of the sample solution, add a mixture of acetonitrile and water (4:1) to make exactly 100 mL, and use this solution as the standard solution. Perform the test with exactly 10 μ L each of the sample solution and standard solution as directed under Liquid Chromatography <2.01> according to the following conditions, and determine each peak area by the automatic integration method: the areas of the peaks, having the relative retention times of about 0.10, about 0.13, about 0.50, and about 1.42 to azelnidipine, obtained from the sample solution, are not larger than 9/20 times, 1/5 times, 2/5 times, and 2/5 times the peak area of azelnidipine obtained from the standard solution, respectively, the area of the peak, other than azelnidipine and the peaks mentioned above, is not larger than 1/10 times the peak area of azelnidipine from the standard solution. Furthermore, the total area of these peaks other than azelnidipine is not larger than 1.75 times the peak area of azelnidipine from the standard solution.

Operating conditions—

Detector, column, column temperature, mobile phase, and flow rate: Proceed as directed in the operating conditions in the Purity (2) under Azelnidipine.

Time span of measurement: About 2 times as long as the retention time of azelnidipine.

System suitability—

Test for required detectability: To exactly 1 mL of the standard solution add a mixture of acetonitrile and water (4:1) to make exactly 20 mL. Confirm that the peak area of azelnidipine obtained with 10 μ L of this solution is equivalent to 3.5 to 6.5% of that with 10 μ L of the standard solution.

System performance: When the procedure is run with 10 μ L of the standard solution under the above operating conditions, the number of theoretical plates and the symmetry factor of the peak of azelnidipine are not less than 15,000 and not more than 1.5, respectively.

System repeatability: When the test is repeated 6 times with 10 μ L of the standard solution under the above operating conditions, the relative standard deviation of the peak area of azelnidipine is not more than 1.0%.

Uniformity of dosage units <6.02> Perform the test according to the following method: it meets the requirement of the Content uniformity test.

To 1 tablet of Azelnidipine Tablets add exactly 1 mL of the internal standard solution per 2 mg of azelnidipine ($C_{33}H_{34}N_4O_6$), and add a mixture of acetonitrile and water (4:1) to make 32 mL. Disintegrate the tablet with occasional shaking, and sonicate for 10 minutes. Centrifuge this solution, pipet V mL of the supernatant liquid, equivalent to 2.5 mg of azelnidipine ($C_{33}H_{34}N_4O_6$), add a mixture of acetonitrile and water (4:1) to make 50 mL, and use this solution as the sample solution. Then, proceed as directed in the Assay.

$$\begin{aligned} &\text{Amount (mg) of azelnidipine (C}_{33}\text{H}_{34}\text{N}_4\text{O}_6) \\ &= M_S \times Q_T/Q_S \times 8/5V \end{aligned}$$

M_S : Amount (mg) of azelnidipine for assay taken

Internal standard solution—A solution of 2,2'-dinaphthyl-

ether in a mixture of acetonitrile and water (4:1) (1 in 1000).

Dissolution <6.10> When the test is performed at 50 revolutions per minute according to the Paddle method, using 900 mL of 1st fluid for dissolution test as the dissolution medium, the dissolution rate in 45 minutes of Azelnidipine Tablets is not less than 75%.

Start the test with 1 tablet of Azelnidipine Tablets, withdraw not less than 20 mL of the medium at the specified minute after starting the test, and filter through a membrane filter with a pore size not exceeding 0.45 μ m. Discard not less than 10 mL of the first filtrate, pipet V mL of the subsequent filtrate, add the dissolution medium to make exactly V' mL so that each mL contains about 8.9 μ g of azelnidipine ($C_{33}H_{34}N_4O_6$), and use this solution as the sample solution. Separately, weigh accurately about 45 mg of azelnidipine for assay, previously dried in vacuum at 70°C for 5 hours, dissolve in ethanol (99.5) to make exactly 25 mL. Pipet 1 mL of this solution, add the dissolution medium to make exactly 200 mL, and use this solution as the standard solution. Determine the absorbances, A_T and A_S , at 270 nm of the sample solution and standard solution as directed under Ultraviolet-visible Spectrophotometry <2.24>, using the dissolution medium as the blank.

Dissolution rate (%) with respect to the labeled amount of azelnidipine ($C_{33}H_{34}N_4O_6$)

$$= M_S \times A_T/A_S \times V'/V \times 1/C \times 18$$

M_S : Amount (mg) of azelnidipine for assay taken

C : Labeled amount (mg) of azelnidipine ($C_{33}H_{34}N_4O_6$) in 1 tablet

Assay Weigh accurately the mass of not less than 20 Azelnidipine Tablets, and powder. Weigh accurately a portion of the powder, equivalent to about 50 mg of azelnidipine ($C_{33}H_{34}N_4O_6$), add exactly 25 mL of the internal standard solution, add 50 mL of a mixture of acetonitrile and water (4:1). After sonicating for 10 minutes, add a mixture of acetonitrile and water (4:1) to make 100 mL. Centrifuge this solution, to 5 mL of the supernatant liquid add a mixture of acetonitrile and water (4:1) to make 50 mL, and use this solution as the sample solution. Separately, weigh accurately about 50 mg of azelnidipine for assay, previously dried in vacuum at 70°C for 5 hours, dissolve in exactly 25 mL of the internal standard solution, and add a mixture of acetonitrile and water (4:1) to make 100 mL. To 5 mL of this solution add a mixture of acetonitrile and water (4:1) to make 50 mL, and use this solution as the standard solution. Perform the test with 10 μ L each of the sample solution and standard solution as directed under Liquid Chromatography <2.01> according to the following conditions, and calculate the ratios, Q_T and Q_S , of the peak area of azelnidipine to that of the internal standard.

$$\text{Amount (mg) of azelnidipine (C}_{33}\text{H}_{34}\text{N}_4\text{O}_6) = M_S \times Q_T/Q_S$$

M_S : Amount (mg) of azelnidipine for assay taken

Internal standard solution—2,2'-dinaphthylether in a mixture of acetonitrile and water (4:1) (1 in 1000).

Operating conditions—

Detector: An ultraviolet absorption photometer (wavelength: 254 nm).

Column: A stainless steel column 4.6 mm in inside diameter and 25 cm in length, packed with octadecylsilanized silica gel for liquid chromatography (5 μ m in particle diameter).

Column temperature: A constant temperature of about 40°C.

Mobile phase: Dissolve 0.9 g of potassium dihydrogen

phosphate in 300 mL of water, add 700 mL of acetonitrile, then adjust to pH 6.0 with dilute sodium hydroxide TS.

Flow rate: Adjust so that the retention time of azelnidipine is about 13 minutes.

System suitability—

System performance: When the procedure is run with 10 μ L of the standard solution under the above operating conditions, azelnidipine and the internal standard are eluted in this order with the resolution between these peaks being not less than 12.

System repeatability: When the test is repeated 6 times with 10 μ L of the standard solution under the above operating conditions, the relative standard deviation of the ratio of the peak area of azelnidipine to that of the internal standard is not more than 1.0%.

Containers and storage Containers—Tight containers.

Storage—Light-resistant.

Azithromycin Hydrate

アジスロマイシン水和物

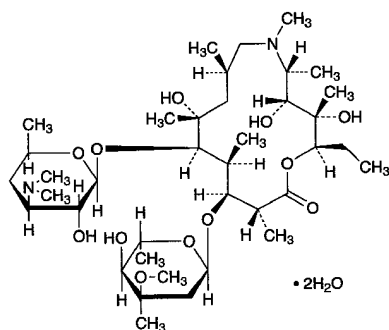

$C_{38}H_{72}N_2O_{12} \cdot 2H_2O$: 785.02
 (2*R*,3*S*,4*S*,5*R*,6*R*,8*R*,11*R*,12*R*,13*S*,14*R*)-5-(3,4,6-Trideoxy-3-dimethylamino- β -D-xylohexopyranosyloxy)-3-(2,6-dideoxy-3-C-methyl-3-O-methyl- α -L-ribo-hexopyranosyloxy)-10-aza-6,12,13-trihydroxy-2,4,6,8,10,11,13-heptamethylhexadecan-14-olide dihydrate
 [117772-70-0]

Azithromycin Hydrate is the derivative of erythromycin.

It contains not less than 945 μ g (potency) and not more than 1030 μ g (potency) per mg, calculated on the anhydrous basis. The potency of Azithromycin Hydrate is expressed as mass (potency) of azithromycin ($C_{38}H_{72}N_2O_{12}$: 748.98).

Description Azithromycin Hydrate occurs as a white crystalline powder.

It is freely soluble in methanol and in ethanol (99.5), and practically insoluble in water.

Identification Determine the infrared absorption spectrum of Azithromycin Hydrate as directed in the potassium bromide disk method under the Infrared Spectrophotometry <2.25>, and compare the spectrum with the Reference Spectrum or the spectrum of Azithromycin RS: both spectra exhibit similar intensities of absorption at the same wave numbers.

Optical rotation <2.49> $[\alpha]_D^{20}$: $-45 - -49^\circ$ (0.4 g calculated on the anhydrous basis, ethanol (99.5), 20 mL, 100 mm).

Purity (1) Heavy metals <1.07>—Proceed with 1.0 g of Azithromycin Hydrate according to Method 2, and perform the test. Prepare the control solution with 1.0 mL of Standard Lead Solution (not more than 10 ppm).

(2) Related substances—Being specified separately when the drug is granted approval based on the Law.

Water <2.48> Not less than 4.0% and not more than 5.0% (0.4 g, volumetric titration, direct titration).

Residue on ignition <2.44> Not more than 0.1% (1 g).

Assay Weigh accurately an amount of Azithromycin Hydrate and Azithromycin RS, equivalent to about 50 mg (potency), dissolve each in an adequate amount of a mixture of acetonitrile and water (3:2), add exactly 2 mL of the internal standard solution and the mixture of acetonitrile and water (3:2) to make 50 mL, and use these solutions as the sample solution and standard solution. Perform the test with 5 μ L each of the sample solution and standard solution as directed under Liquid Chromatography <2.01> according to the following conditions, and calculate the ratios, Q_T and Q_S , of the peak area of azithromycin to that of the internal standard.

$$\text{Amount } [\mu\text{g (potency)}] \text{ of azithromycin } (C_{38}H_{72}N_2O_{12}) \\ = M_S \times Q_T / Q_S \times 1000$$

M_S : Amount [mg (potency)] of Azithromycin RS taken

Internal standard solution—A solution of 4,4'-bis(diethylamino)benzophenone in acetonitrile (3 in 4000).

Operating conditions—

Detector: An ultraviolet absorption photometer (wavelength: 215 nm).

Column: A stainless steel column 4.6 mm in inside diameter and 25 cm in length, packed with octadecylsilanized polyvinyl alcohol gel polymer for liquid chromatography (5 μ m in particle diameter).

Column temperature: A constant temperature of about 40°C.

Mobile phase: Dissolve 6.97 g of dipotassium hydrogen phosphate in about 750 mL of water, adjust the pH to 11.0 with potassium hydroxide TS, and add water to make 1000 mL. To 400 mL of this solution add 600 mL of acetonitrile for liquid chromatography.

Flow rate: Adjust so that the retention time of azithromycin is about 10 minutes.

System suitability—

System performance: When the procedure is run with 5 μ L of the standard solution under the above operating conditions, azithromycin and the internal standard are eluted in this order with the resolution between these peaks being not less than 2.0.

System repeatability: When the test is repeated 6 times with 5 μ L of the standard solution under the above operating conditions, the relative standard deviation of the ratios of the peak area of azithromycin to that of the internal standard is not more than 1.0%.

Containers and storage Containers—Tight containers.

Azosemide

アゾセミド

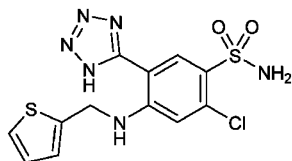
 $C_{12}H_{11}ClN_6O_2S_2$; 370.84

2-Chloro-5-(1*H*-tetrazol-5-yl)-4-[(thien-2-ylmethyl)amino]benzenesulfonamide
[27589-33-9]

Azosemide, when dried, contains not less than 99.0% and not more than 101.0% of azosemide ($C_{12}H_{11}ClN_6O_2S_2$).

Description Azosemide occurs as a white to yellow-white crystalline powder.

It is freely soluble in *N,N*-dimethylformamide, slightly soluble in methanol and in ethanol (99.5), and practically insoluble in water.

It dissolves in dilute sodium hydroxide TS.

It is gradually colored to yellow by light.

Melting point: about 226°C (with decomposition).

Identification (1) Determine the absorption spectrum of a solution of Azosemide in dilute sodium hydroxide TS (3 in 500,000) as directed under Ultraviolet-visible Spectrophotometry <2.24>, and compare the spectrum with the Reference Spectrum: both spectra exhibit similar intensities of absorption at the same wavelengths.

(2) Determine the infrared absorption spectrum of Azosemide, previously dried, as directed in the potassium bromide disk method under Infrared Spectrophotometry <2.25>, and compare the spectrum with the Reference Spectrum: both spectra exhibit similar intensities of absorption at the same wave numbers.

Purity (1) Chloride <1.03>—To 1.0 g of Azosemide add 60 mL of dilute sodium hydroxide TS, dissolve by warming. After cooling, add 0.5 mL of nitric acid and filter. To 30 mL of the filtrate add 6 mL of dilute nitric acid and water to make 50 mL. Perform the test using this solution as the test solution. Prepare the control solution with 0.45 mL of 0.01 mol/L hydrochloric acid VS (not more than 0.032%).

(2) Heavy metal <1.07>—Proceed with 1.0 g of Azosemide according to Method 2, and perform the test. Prepare the control solution with 2.0 mL of Standard Lead Solution (not more than 20 ppm).

(3) Primary aromatic amines—Dissolve 20 mg of Azosemide in 5 mL of *N,N*-dimethylformamide, add 12 mL of water, 1.0 mL of a solution of sodium nitrite (1 in 200) and 2.0 mL of diluted hydrochloric acid (1 in 10) under ice-cooling, shake, and allow to stand for 3 minutes. Add 1.0 mL of ammonium amidosulfate TS, shake thoroughly, allow to stand for 3 minutes, and add 1.0 mL of a solution of *N*-1-naphthylethylenediamine dihydrochloride (1 in 200). Shake this solution, and add *N,N*-dimethylformamide to make exactly 50 mL. Determine the absorbance of this solution at 540 nm as directed under Ultraviolet-visible Spectrophotometry <2.24>, using a solution prepared in the same manner with 5 mL of *N,N*-dimethylformamide as the blank: the absorbance is not more than 0.15.

Loss on drying <2.41> Not more than 0.5% (1 g, 105°C, 3 hours).

Residue on ignition <2.44> Not more than 0.1% (1 g).

Assay Weigh accurately about 0.6 g of Azosemide, previously dried, dissolve in 50 mL of *N,N*-dimethylformamide, and titrate <2.50> with 0.1 mol/L potassium hydroxide-ethanol VS until the color of the solution changes from yellow to yellow-green (indicator: 10 drops of thymol blue-*N,N*-dimethylformamide TS). Perform a blank determination in the same manner with a solution prepared by adding 15 mL of ethanol (95) to 50 mL of *N,N*-dimethylformamide, and make any necessary correction.

Each mL of 0.1 mol/L potassium hydroxide-ethanol VS = 37.08 mg of $C_{12}H_{11}ClN_6O_2S_2$

Containers and storage Containers—Tight containers.

Storage—Light-resistant.

Azosemide Tablets

アゾセミド錠

Azosemide Tablets contain not less than 95.0% and not more than 105.0% of the labeled amount of azosemide ($C_{12}H_{11}ClN_6O_2S_2$; 370.84).

Method of preparation Prepare as directed under Tablets, with Azosemide.

Identification To a quantity of powdered Azosemide Tablets, equivalent to 60 mg of Azosemide, add dilute sodium hydroxide TS to make 100 mL, shake, and filter. To 1 mL of the filtrate add dilute sodium hydroxide TS to make 100 mL. Determine the absorption spectrum of this solution as directed under Ultraviolet-visible Spectrophotometry <2.24>: it exhibits maxima between 234 nm and 238 nm, between 272 nm and 276 nm and between 324 nm and 330 nm.

Purity Primary aromatic amines—To a quantity of powdered Azosemide Tablets, equivalent to 20 mg of Azosemide, add 5 mL of *N,N*-dimethylformamide, and allow to stand with occasional shaking. Add 12 mL of water, 1.0 mL of a solution of sodium nitrite (1 in 200) and 2.0 mL of diluted hydrochloric acid (1 in 10) under ice-cooling, shake, and allow to stand for 3 minutes. Add 1.0 mL of ammonium amidosulfate TS, shake thoroughly, and allow to stand for 3 minutes. Add 1.0 mL of a solution of *N*-1-naphthylethylenediamine dihydrochloride (1 in 200), and shake. Add *N,N*-dimethylformamide to make exactly 50 mL, centrifuge, and use the supernatant liquid as the sample solution. Determine the absorbance of the sample solution at 540 nm as directed under Ultraviolet-visible Spectrophotometry <2.24>, using a solution prepared in the same manner with 5 mL of *N,N*-dimethylformamide as the blank: the absorbance is not more than 0.15.

Uniformity of dosage unit <6.02> Perform the Mass variation test, or the Content uniformity test according to the following method: it meets the requirement.

To 1 tablet of Azosemide Tablets add dilute sodium hydroxide TS to make exactly *V* mL so that each mL contains about 0.6 mg of azosemide ($C_{12}H_{11}ClN_6O_2S_2$), shake thoroughly, and centrifuge. Pipet 10 mL of the supernatant liquid, and add dilute sodium hydroxide TS to make exactly 100 mL. Pipet 10 mL of this solution, add dilute sodium hydroxide TS to make exactly 50 mL, and use this solution as

the sample solution. Separately, weigh accurately about 60 mg of azosemide for assay, previously dried at 105°C for 3 hours, and dissolve in dilute sodium hydroxide TS to make exactly 100 mL. Pipet 10 mL of this solution, and add dilute sodium hydroxide TS to make exactly 100 mL. Pipet 10 mL of this solution, add dilute sodium hydroxide TS to make exactly 50 mL, and use this solution as the standard solution. Determine the absorbances, A_T and A_S , of the sample solution and standard solution at 274 nm as directed under Ultraviolet-visible Spectrophotometry <2.24>.

$$\begin{aligned} &\text{Amount (mg) of azosemide (C}_{12}\text{H}_{11}\text{ClN}_6\text{O}_2\text{S}_2) \\ &= M_S \times A_T/A_S \times V/100 \end{aligned}$$

M_S : Amount (mg) of azosemide for assay taken

Dissolution <6.10> When the test is performed at 50 revolutions per minute according to the Paddle method, using 900 mL of 2nd fluid for dissolution test as the dissolution medium, the dissolution rate in 60 minutes of a 30-mg tablet and in 90 minutes of a 60-mg tablet are not less than 70%, respectively.

Start the test with 1 tablet of Azosemide Tablets, withdraw not less than 20 mL of the medium at the specified minute after starting the test, and filter through a membrane filter with a pore size not exceeding 0.5 μm . Discard not less than 10 mL of the first filtrate, pipet V mL of the subsequent filtrate, and add the dissolution medium to make exactly V' mL so that each mL contains about 33 μg of azosemide ($\text{C}_{12}\text{H}_{11}\text{ClN}_6\text{O}_2\text{S}_2$). Pipet 8 mL of this solution, add 0.2 mol/L sodium hydroxide TS to make exactly 20 mL, and use this solution as the sample solution. Separately, weigh accurately about 22 mg of azosemide for assay, previously dried at 105°C for 3 hours, and dissolve in 0.2 mol/L sodium hydroxide TS to make exactly 100 mL. Pipet 5 mL of this solution, and add 0.2 mol/L sodium hydroxide TS to make exactly 50 mL. Pipet 15 mL of this solution, add the dissolution medium to make exactly 25 mL, and use this solution as the standard solution. Determine the absorbances, A_T and A_S , of the sample solution and standard solution at 274 nm as directed under Ultraviolet-visible Spectrophotometry <2.24>, using a solution prepared by adding 0.2 mol/L sodium hydroxide TS to 8 mL of the dissolution medium to make 20 mL as the blank.

Dissolution rate (%) with respect to the labeled amount of azosemide ($\text{C}_{12}\text{H}_{11}\text{ClN}_6\text{O}_2\text{S}_2$)

$$= M_S \times A_T/A_S \times V'/V \times 1/C \times 135$$

M_S : Amount (mg) of azosemide for assay taken

C : Labeled amount (mg) of azosemide ($\text{C}_{12}\text{H}_{11}\text{ClN}_6\text{O}_2\text{S}_2$) in 1 tablet

Assay Weigh accurately the mass of not less than 20 tablets of Azosemide Tablets, and powder. Weigh accurately a portion of the powder, equivalent to about 60 mg of azosemide ($\text{C}_{12}\text{H}_{11}\text{ClN}_6\text{O}_2\text{S}_2$), add dilute sodium hydroxide TS to make exactly 100 mL, shake thoroughly, and filter. Discard the first 5 mL of the filtrate, pipet 5 mL of the subsequent filtrate, add exactly 10 mL of the internal standard solution, add the mobile phase to make 100 mL, and use this solution as the sample solution. Separately, weigh accurately about 60 mg of azosemide for assay, previously dried at 105°C for 3 hours, and dissolve in dilute sodium hydroxide TS to make exactly 100 mL. Pipet 5 mL of this solution, add exactly 10 mL of the internal standard solution, add the mobile phase to make 100 mL, and use this solution as the standard solution. Perform the test with 10 μL each of the sample solution and standard solution as directed under Liquid Chromatography <2.01> according to the following conditions, and cal-

culate the ratios, Q_T and Q_S , of the peak area of azosemide to that of the internal standard.

$$\begin{aligned} &\text{Amount (mg) of azosemide (C}_{12}\text{H}_{11}\text{ClN}_6\text{O}_2\text{S}_2) \\ &= M_S \times Q_T/Q_S \end{aligned}$$

M_S : Amount (mg) of azosemide for assay taken

Internal standard solution—A solution of propyl parahydroxybenzoate in the mobile phase (3 in 5000).

Operating conditions—

Detector: An ultraviolet absorption photometer (wavelength: 280 nm).

Column: A stainless steel column 4.6 mm in inside diameter and 15 cm in length, packed with octadecylsilanized silica gel for liquid chromatography (5 μm in particle diameter).

Column temperature: A constant temperature of about 25°C.

Mobile phase: A mixture of 0.03 mol/L potassium dihydrogen phosphate solution, acetonitrile and methanol (55:27:18).

Flow rate: Adjust so that the retention time of azosemide is about 5 minutes.

System suitability—

System performance: When the procedure is run with 10 μL of the standard solution under the above operating conditions, azosemide and the internal standard are eluted in this order with the resolution between these peaks being not less than 8.

System repeatability: When the test is repeated 6 times with 10 μL of the standard solution under the above operating conditions, the relative standard deviation of the ratio of the peak area of azosemide to that of the internal standard is not more than 1.0%.

Containers and storage Containers—Tight containers.

Aztreonam

アズトレオナム

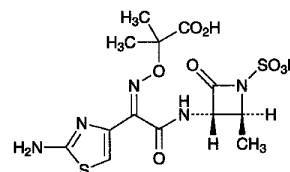

$\text{C}_{13}\text{H}_{17}\text{N}_5\text{O}_8\text{S}_2$: 435.43

2-[(Z)-(2-Aminothiazol-4-yl)-[(2S,3S)-2-methyl-4-oxo-1-sulfoazetidin-3-ylcarbamoyl]methylamino]oxy}-2-methyl-1-propanoic acid
[78110-38-0]

Aztreonam contains not less than 920 μg (potency) and not more than 1030 μg (potency) per mg, calculated on the anhydrous basis. The potency of Aztreonam is expressed as mass (potency) of aztreonam ($\text{C}_{13}\text{H}_{17}\text{N}_5\text{O}_8\text{S}_2$).

Description Aztreonam occurs as a white to yellowish white crystalline powder.

It is freely soluble in dimethylsulfoxide, slightly soluble in water and in methanol, and very slightly soluble in ethanol (95).

Identification (1) Determine the absorption spectrum of a solution of Aztreonam (3 in 100,000) as directed under Ultraviolet-visible Spectrophotometry <2.24>, and compare the

spectrum with the Reference Spectrum or the spectrum of a solution of Aztreonam RS prepared in the same manner as the sample solution: both spectra exhibit similar intensities of absorption at the same wavelengths.

(2) Determine the spectrum of a solution of Aztreonam in deuterated dimethylsulfoxide for nuclear magnetic resonance spectroscopy (1 in 10), using a light hydrogen substance existing in deuterated dimethylsulfoxide for nuclear magnetic resonance spectroscopy as an internal reference compound and 2.50 ppm for its chemical shift, as directed under Nuclear Magnetic Resonance Spectroscopy <2.21> (¹H): it exhibits a multiple signal at around δ 1.5 ppm, and a single signal at around δ 7.0 ppm. The ratio of integrated intensity of each signal is 9:1.

Optical rotation <2.49> $[\alpha]_D^{20}$: $-26 - -32^\circ$ (0.25 g calculated on the anhydrous bases, water, 50 mL, 100 mm).

pH <2.54> Dissolve 0.05 g of Aztreonam in 10 mL of water: the pH of this solution is between 2.2 and 2.8.

Purity (1) Clarity and color of solution—Dissolve 1.0 g of Aztreonam in 20 mL of dimethylsulfoxide: the solution is clear, and its absorbance at 420 nm, determined as directed under Ultraviolet-visible Spectrophotometry <2.24>, is not more than 0.06.

(2) Heavy metals <1.07>—Proceed with 2.0 g of Aztreonam according to Method 2, and perform the test. Prepare the control solution with 2.0 mL of Standard Lead Solution (not more than 10 ppm).

(3) Related substances—Dissolve 40 mg of Aztreonam in 100 mL of water, and use this solution as the sample solution. Pipet 2 mL of the sample solution, add water to make exactly 100 mL, and use this solution as the standard solution. Perform the test with exactly 25 μ L each of the sample solution and standard solution as directed under Liquid Chromatography <2.01> according to the following conditions, and determine each peak area of both solutions by the automatic integration method: the area of the peak other than aztreonam obtained from the sample solution is not larger than the peak area of aztreonam from the standard solution, and the total area of peaks other than aztreonam from the sample solution is not larger than 2.5 times the peak area of aztreonam from the standard solution.

Operating conditions—

Column, column temperature, mobile phase, and flow rate: Proceed as directed in the operating conditions in the Assay.

Detector: An ultraviolet absorption photometer (wavelength: 254 nm).

Time span of measurement: About 4 times as long as the retention time of aztreonam, beginning after the solvent peak.

System suitability—

Test for required detectability: To 5 mL of the standard solution add water to make 10 mL, and use this solution as the solution for system suitability test. Pipet 1 mL of the solution for system suitability test, and add water to make exactly 10 mL. Confirm that the peak area of aztreonam obtained with 25 μ L of this solution is equivalent to 7 to 13% of that with 25 μ L of the solution for system suitability test.

System performance: When the procedure is run under the above operating conditions with 25 μ L of the standard solution obtained in the Assay, the internal standard and aztreonam are eluted in this order with the resolution between these peaks being not less than 4.

System repeatability: When the test is repeated 6 times with 25 μ L of the standard solution under the above operat-

ing conditions, the relative standard deviation of the peak areas of aztreonam is not more than 2.0%.

Water <2.48> Not more than 2.0% (0.5 g, volumetric titration, direct titration).

Residue on ignition <2.44> Not more than 0.1% (1 g).

Assay Weigh accurately an amount of Aztreonam and Aztreonam RS, equivalent to about 20 mg (potency), dissolve each in 70 mL of water, add exactly 10 mL of the internal standard solution and water to make 100 mL, and use these solutions as the sample solution and standard solution, respectively. Perform the test with 25 μ L each of these solutions as directed under Liquid Chromatography <2.01> according to the following conditions, and calculate the ratios, Q_T and Q_S , of the peak area of aztreonam to that of the internal standard.

$$\text{Amount } [\mu\text{g (potency)}] \text{ of aztreonam (C}_{13}\text{H}_{17}\text{N}_5\text{O}_8\text{S}_2) \\ = M_S \times Q_T / Q_S \times 1000$$

M_S : Amount [mg (potency)] of Aztreonam RS taken

Internal standard solution—A solution of 4-aminobenzoic acid (1 in 6250).

Operating conditions—

Detector: An ultraviolet absorption photometer (wavelength: 280 nm).

Column: A stainless steel column 4.6 mm in inside diameter and 25 cm in length, packed with octadecylsilanized silica gel for liquid chromatography (10 μ m in particle diameter).

Column temperature: A constant temperature of about 40°C.

Mobile phase: Dissolve 1.7 g of tetrabutylammonium hydrogensulfate in 300 mL of water, adjust to pH 3.0 with 0.5 mol/L disodium hydrogenphosphate TS, and add water to make 1000 mL. To 650 mL of this solution add 350 mL of methanol.

Flow rate: Adjust so that the retention time of aztreonam is about 8 minutes.

System suitability—

System performance: When the procedure is run with 25 μ L of the standard solution under the above operating conditions, the internal standard and aztreonam are eluted in this order with the resolution between these peaks being not less than 4.

System repeatability: When the test is repeated 6 times with 25 μ L of the standard solution under the above operating conditions, the relative standard deviation of the ratios of the peak area of aztreonam to that of the internal standard is not more than 1.5%.

Containers and storage Containers—Tight containers.

Storage—Light-resistant.

Aztreonam for Injection

注射用アズトレオナム

Aztreonam for Injection is a preparation for injection which is dissolved before use.

It contains not less than 93.0% and not more than 107.0% of the labeled potency of aztreonam (C₁₃H₁₇N₅O₈S₂; 435.43).

Method of preparation Prepare as directed under Injections, with Aztreonam.

Description Aztreonam for Injection is white to yellow-

white masses or powder.

Identification (1) Dissolve an amount of Aztreonam for Injection, equivalent to 6 mg (potency) of Aztreonam, in 1 mL of hydroxylammonium chloride-ethanol TS, allow to stand for 3 minutes, add 1 mL of acidic ammonium iron (III) sulfate TS, and mix: a red-brown color develops.

(2) Dissolve an amount of Aztreonam for Injection, equivalent to 3 mg (potency) of Aztreonam, in 100 mL of water, and determine the absorption spectrum of the solution as directed under Ultraviolet-visible Spectrophotometry <2.24>: it exhibits a maximum between 289 nm and 293 nm.

pH <2.54> The pH of a solution prepared by dissolving an amount of Aztreonam for Injection, equivalent to 1.0 g (potency) of Aztreonam, in 10 mL of water is 4.5 to 7.0.

Purity Clarity and color of solution—Dissolve an amount of Aztreonam for Injection, equivalent to 1.0 g (potency) of Aztreonam, in 10 mL of water: the solution is clear, and its absorbance <2.24> at 450 nm is not more than 0.06.

Water <2.48> Not more than 2.0% (0.5 g, volumetric titration, direct titration).

Bacterial endotoxins <4.01> Less than 0.10 EU/mg (potency).

Uniformity of dosage units <6.02> It meets the requirement of the Mass variation test.

Foreign insoluble matter <6.06> Perform the test according to Method 2: it meets the requirement.

Insoluble particulate matter <6.07> It meets the requirement.

Sterility <4.06> Perform the test according to the Membrane filtration method: it meets the requirement.

Assay Take an amount of Aztreonam for Injection, equivalent to about 5 g (potency) of Aztreonam, dissolve the contents with a suitable amount of water, and transfer to a 100-mL volumetric flask. Wash each container with water, combine the washings and the solution, and add water to make exactly 100 mL. Pipet 10 mL of this solution, and add water to make exactly 50 mL. Pipet 2 mL of this solution, add exactly 10 mL of the internal standard solution and water to make 100 mL, and use this solution as the sample solution. Separately, weigh accurately an amount of Aztreonam RS, equivalent to about 20 mg (potency), dissolve in a suitable amount of water, add exactly 10 mL of the internal standard solution and water to make 100 mL, and use this solution as the standard solution. Then, proceed as directed in the Assay under Aztreonam.

$$\begin{aligned} &\text{Amount [mg (potency)] of aztreonam (C}_{13}\text{H}_{17}\text{N}_5\text{O}_8\text{S}_2) \\ &= M_S \times Q_T / Q_S \times 250 \end{aligned}$$

M_S : Amount [mg (potency)] of Aztreonam RS taken

Internal standard solution—A solution of 4-aminobenzoic acid (1 in 6250).

Containers and storage Containers—Hermetic containers.
Storage—Light-resistant.

Bacampicillin Hydrochloride

バカンピシリン塩酸塩

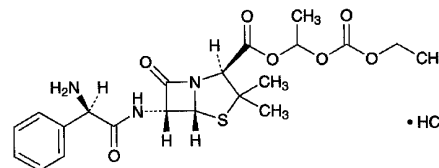

$\text{C}_{21}\text{H}_{27}\text{N}_3\text{O}_7\text{S} \cdot \text{HCl}$: 501.98

1-Ethoxycarbonyloxyethyl (2*S*,5*R*,6*R*)-6-[(2*R*)-2-amino-2-phenylacetyl-amino]-3,3-dimethyl-7-oxo-4-thia-1-azabicyclo[3.2.0]heptane-2-carboxylate monohydrochloride [37661-08-8]

Bacampicillin Hydrochloride is a hydrochloride of ampicillin ethoxycarbonyloxyethyl ester.

It contains not less than 626 μg (potency) and not more than 710 μg (potency) per mg, calculated on the anhydrous basis. The potency of Bacampicillin Hydrochloride is expressed as mass (potency) of ampicillin ($\text{C}_{16}\text{H}_{19}\text{N}_3\text{O}_4\text{S}$: 349.40).

Description Bacampicillin Hydrochloride occurs as a white to pale yellow crystalline powder.

It is freely soluble in methanol and in ethanol (95), and soluble in water.

Identification (1) Determine the absorption spectrum of a solution of Bacampicillin Hydrochloride in methanol (1 in 1000) as directed under Ultraviolet-visible Spectrophotometry <2.24>, and compare the spectrum with the Reference Spectrum or the spectrum of a solution of Bacampicillin Hydrochloride RS prepared in the same manner as the sample solution: both spectra exhibit similar intensities of absorption at the same wavelengths.

(2) Determine the infrared absorption spectrum of Bacampicillin Hydrochloride as directed in the potassium chloride disk method under Infrared Spectrophotometry <2.25>, and compare the spectrum with the Reference Spectrum or the spectrum of Bacampicillin Hydrochloride RS: both spectra exhibit similar intensities of absorption at the same wave numbers.

(3) A solution of Bacampicillin Hydrochloride (1 in 50) responds to Qualitative Tests <1.09> for chloride.

Optical rotation <2.49> $[\alpha]_D^{20}$: +140 – +170° (0.1 g calculated on the anhydrous basis, ethanol (95), 25 mL, 100 mm).

Purity (1) Heavy metals <1.07>—Proceed with 1.0 g of Bacampicillin Hydrochloride according to Method 2, and perform the test. Prepare the control solution with 2.0 mL of Standard Lead Solution (not more than 20 ppm).

(2) Arsenic <1.11>—Prepare the test solution with 1.0 g of Bacampicillin Hydrochloride according to Method 3, and perform the test (not more than 2 ppm).

(3) Free ampicillin—Carry out the determination immediately after preparing the sample solution. Weigh accurately about 0.1 g of Bacampicillin Hydrochloride, dissolve in exactly 10 mL of the internal standard solution, add the mobile phase to make 20 mL, and use this solution as the sample solution. Separately, weigh accurately an amount of Ampicillin RS, equivalent to about 25 mg (potency), and dissolve in water to make exactly 100 mL. Pipet 4 mL of this solution, add exactly 10 mL of the internal standard solution, add the mobile phase to make 20 mL, and use this solution as the standard solution. Perform the test with 10 μL each of the

sample solution and standard solution as directed under Liquid Chromatography <2.01> according to the following conditions, and calculate the ratios, Q_T and Q_S , of the peak area of ampicillin to that of the internal standard in each solution. The amount of ampicillin, calculated by the following equation, is not more than 1.0%.

$$\begin{aligned} \text{Amount (\%)} \text{ of ampicillin (C}_{16}\text{H}_{19}\text{N}_3\text{O}_4\text{S)} \\ = M_S/M_T \times Q_T/Q_S \times 4 \end{aligned}$$

M_S : Amount [mg (potency)] of Ampicillin RS taken

M_T : Amount (mg) of Bacampicillin Hydrochloride taken

Internal standard solution—A solution of anhydrous caffeine in the mobile phase (1 in 25,000).

Operating conditions—

Detector: An ultraviolet absorption photometer (wavelength: 230 nm).

Column: A stainless steel column 4.6 mm in inside diameter and 15 cm in length, packed with octadecylsilanized silica gel for liquid chromatography (5 μm in particle diameter).

Column temperature: A constant temperature of about 25°C.

Mobile phase: Dissolve 1.22 g of potassium dihydrogen phosphate in water to make 900 mL, and add 100 mL of acetonitrile.

Flow rate: Adjust so that the retention time of ampicillin is about 7 minutes.

System suitability—

System performance: When the procedure is run with 10 μL of the standard solution under the above operating conditions, ampicillin and the internal standard are eluted in this order with the resolution between these peaks being not less than 5.

System repeatability: When the test is repeated 6 times with 10 μL of the standard solution under the above operating conditions, the relative standard deviation of the ratio of the peak area of ampicillin to that of the internal standard is not more than 2.0%.

Water <2.48> Not more than 1.0% (0.5 g, volumetric titration, direct titration).

Residue on ignition <2.44> Not more than 1.5% (1 g).

Assay Weigh accurately an amount of Bacampicillin Hydrochloride and Bacampicillin Hydrochloride RS, equivalent to about 40 mg (potency), dissolve each in water to make exactly 100 mL, and use these solutions as the sample solution and standard solution. Perform the test with exactly 20 μL each of the sample solution and standard solution as directed under Liquid Chromatography <2.01> according to the following conditions, and determine the peak areas, A_T and A_S , of bacampicillin in each solution.

$$\begin{aligned} \text{Amount } [\mu\text{g (potency)}] \text{ of ampicillin (C}_{16}\text{H}_{19}\text{N}_3\text{O}_4\text{S)} \\ = M_S \times A_T/A_S \times 1000 \end{aligned}$$

M_S : Amount [mg (potency)] of Bacampicillin Hydrochloride RS taken

Operating conditions—

Detector: An ultraviolet absorption photometer (wavelength: 254 nm).

Column: A stainless steel column 4.6 mm in inside diameter and 15 cm in length, packed with octadecylsilanized silica gel for liquid chromatography (5 μm in particle diameter).

Column temperature: A constant temperature of about 25°C.

Mobile phase: To 500 mL of diluted 2 mol/L sodium dihydrogen phosphate TS (1 in 100), add diluted 0.05 mol/L dis-

odium hydrogen phosphate TS (2 in 5) to adjust the pH to 6.8. To 500 mL of this solution add 500 mL of acetonitrile.

Flow rate: Adjust so that the retention time of bacampicillin is about 6.5 minutes.

System suitability—

System performance: When the procedure is run with 20 μL of the standard solution under the above operating conditions, the number of theoretical plates and the symmetry factor of the peak of bacampicillin are not less than 10,000 and not more than 2, respectively.

System repeatability: When the test is repeated 6 times with 20 μL of the standard solution under the above operating conditions, the relative standard deviation of peak areas of bacampicillin is not more than 2.0%.

Containers and storage Containers—Tight containers.

Bacitracin

バシトラシン

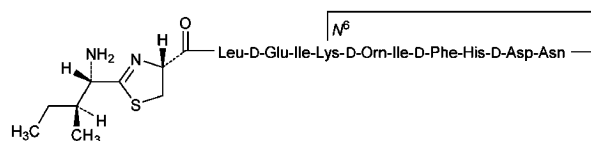

Bacitracin A

$\text{C}_{66}\text{H}_{103}\text{N}_{17}\text{O}_{16}\text{S}$: 1422.69

[22601-59-8]

[1405-87-4, Bacitracin]

Bacitracin is a mixture of peptide substances having antibacterial activity including bacitracin A as the main component produced by the growth of *Bacillus subtilis* or *Bacillus licheniformis*.

It contains not less than 60 Units per mg, calculated on the dried basis. The potency of Bacitracin is expressed as unit calculated from the amount of bacitracin A ($\text{C}_{66}\text{H}_{103}\text{N}_{17}\text{O}_{16}\text{S}$: 1422.69). One unit of Bacitracin is equivalent to 23.8 μg of bacitracin A ($\text{C}_{66}\text{H}_{103}\text{N}_{17}\text{O}_{16}\text{S}$).

Description Bacitracin occurs as a white to light brown powder.

It is freely soluble in water, and slightly soluble in ethanol (99.5).

Identification (1) To 3 mL of a solution of Bacitracin (1 in 100) add 3 mL of 4-dimethylaminobenzaldehyde TS, shake until red-rosy to red-purple color appears, then add several drops of a solution of sodium nitrite (1 in 100), and shake: a green to dark green color is produced.

(2) Dissolve 60 mg each of Bacitracin and Bacitracin RS in 10 mL of water, and use these solutions as the sample solution and standard solution. Perform the test with these solutions as directed under Thin-layer Chromatography <2.03>. Spot 1 μL each of the sample solution and standard solution on a plate of silica gel for thin-layer chromatography. Develop the plate with a mixture of 1-butanol, acetic acid (100), water, pyridine and ethanol (99.5) (30:15:10:6:5) to a distance of about 10 cm, and air-dry the plate. Spray evenly ninhydrin TS on the plate, and heat the plate at 110°C for 5 minutes: the spots obtained from the sample solution and standard solution show the same R_f value.

Purity (1) Heavy metals <1.07>—Proceed with 1.0 g of Bacitracin according to Method 2, and perform the test.

Prepare the control solution with 2.0 mL of Standard Lead Solution (not more than 20 ppm).

(2) Related substances—Dissolve 0.15 g of Bacitracin in 0.05 mol/L sulfuric acid TS to make 100 mL. To 2 mL of this solution add 0.05 mol/L sulfuric acid TS to make 10 mL, and determine the absorbances of this solution, A_1 and A_2 , at 252 nm and 290 nm as directed under Ultraviolet-visible Spectrophotometry <2.24>: A_2/A_1 is not more than 0.20.

Loss on drying <2.41> Not more than 5.0% (1 g, in vacuum, 60°C, 3 hours).

Residue on ignition <2.44> Not more than 1.0% (1 g).

Assay Perform the test according to the Cylinder-plate method as directed under Microbial Assay for Antibiotics <4.02> according to the following conditions.

(i) Test organism—*Micrococcus luteus* ATCC 10240.

(ii) Culture medium—Use the medium iii in 3) under (1) Agar media for seed and base layer.

(iii) Standard solutions—Weigh accurately an amount of Bacitracin RS, equivalent to about 400 units, dissolve in phosphate buffer solution (pH 6.0) to make exactly 20 mL, and use this solution as the standard stock solution. Keep the standard stock solution at not exceeding 10°C and use within 2 days. Take exactly a suitable amount of the standard stock solution before use, add phosphate buffer solution (pH 6.0) to make solutions so that each mL contains 2 units and 0.5 units, and use these solutions as the high concentration standard solution and low concentration standard solution, respectively.

(iv) Sample solutions—Weigh accurately an amount of Bacitracin, equivalent about 400 units, dissolve in phosphate buffer solution (pH 6.0) to make exactly 20 mL. Take exactly a suitable amount of this solution, add phosphate buffer solution (pH 6.0) to make solutions so that each mL contains 2 units and 0.5 units, and use these solutions as the high concentration sample solution and low concentration sample solution, respectively.

Containers and storage Containers—Tight containers.

Storage—In a cold place.

Baclofen

バクロフェン

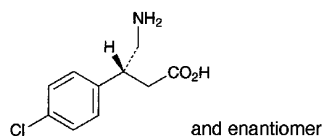

$C_{10}H_{12}ClNO_2$: 213.66
(3*RS*)-4-Amino-3-(4-chlorophenyl)butanoic acid
[1134-47-0]

Baclofen contains not less than 98.5% of baclofen ($C_{10}H_{12}ClNO_2$), calculated on the anhydrous basis.

Description Baclofen occurs as a white to pale yellow-white crystalline powder.

It is freely soluble in acetic acid (100), slightly soluble in water, very slightly soluble in methanol and in ethanol (95), and practically insoluble in diethyl ether.

It dissolves in dilute hydrochloric acid.

Identification (1) To 5 mL of a solution of Baclofen (1 in 1000) add 1 mL of ninhydrin TS, and heat on a water bath

for 3 minutes: a blue-purple color develops.

(2) Determine the absorption spectrum of a solution of Baclofen in 0.1 mol/L hydrochloric acid TS (1 in 2000) as directed under Ultraviolet-visible Spectrophotometry <2.24>, and compare the spectrum with the Reference Spectrum or the spectrum of a solution of Baclofen RS prepared in the same manner as the sample solution: both spectra exhibit similar intensities of absorption at the same wavelengths.

(3) Perform the test with Baclofen as directed under Flame Coloration Test <1.04> (2): a green color appears.

Purity (1) Chloride <1.03>—Dissolve 0.5 g of Baclofen in 50 mL of acetic acid (100), and add water to make 100 mL. To 10 mL of this solution add 6 mL of dilute nitric acid and water to make 50 mL. Perform the test using this solution as the test solution. Prepare the control solution as follows: to 0.30 mL of 0.01 mol/L hydrochloric acid VS add 5 mL of acetic acid (100), 6 mL of dilute nitric acid and water to make 50 mL (not more than 0.21%).

(2) Heavy metals <1.07>—Proceed with 2.0 g of Baclofen according to Method 2, and perform the test. Prepare the control solution with 2.0 mL of Standard Lead Solution (not more than 10 ppm).

(3) Arsenic <1.11>—Prepare the test solution with 1.0 g of Baclofen according to Method 3, and perform the test (not more than 2 ppm).

(4) Related substances—Dissolve 50 mg of Baclofen in 50 mL of the mobile phase, and use this solution as the sample solution. Pipet 1.0 mL and 1.5 mL of the sample solution, to each add the mobile phase to make exactly 100 mL, and use these solutions as the standard solutions (1) and (2), respectively. Perform the test with exactly 25 μ L each of the sample solution and standard solutions (1) and (2) as directed under Liquid Chromatography <2.01> according to the following conditions. Determine each peak height of these solutions: each height of the peaks other than the peak of baclofen obtained from the sample solution is not larger than the peak height of baclofen from the standard solution (1), and the total height of these peaks is not larger than the peak height of baclofen from the standard solution (2).

Operating conditions—

Detector: An ultraviolet absorption photometer (wavelength: 268 nm).

Column: A stainless steel column 4 mm in inside diameter and 25 cm in length, packed with octadecylsilanized silica gel for liquid chromatography (10 μ m in particle diameter).

Column temperature: A constant temperature of about 25°C.

Mobile phase: A mixture of methanol and diluted acetic acid (100) (1 in 900) (3:2).

Flow rate: Adjust so that the retention time of baclofen is about 4 minutes.

Time span of measurement: About 3 times as long as the retention time of baclofen, beginning after the solvent peak.

System suitability—

Test for required detectability: Adjust the sensitivity so that the peak height of baclofen obtained with 25 μ L of the standard solution (1) is between 5 and 10 mm.

System performance: Dissolve 0.40 g of Baclofen and 5 mg of methyl parahydroxybenzoate in 200 mL of the mobile phase. To 10 mL of this solution add the mobile phase to make 100 mL. When the procedure is run with 25 μ L of this solution under the above operating conditions, baclofen and methyl parahydroxybenzoate are eluted in this order with the resolution between these peaks being not less than 5.

System repeatability: When the test is repeated 6 times with 25 μ L of the standard solution (1) under the above

operating conditions, the relative standard deviation of the peak heights of baclofen is not more than 3.0%.

Water <2.48> Not more than 1.0% (1 g, direct titration).

Residue on ignition <2.44> Not more than 0.3% (1 g).

Assay Weigh accurately about 0.5 g of Baclofen, dissolve in 80 mL of acetic acid (100), and titrate <2.50> with 0.1 mol/L perchloric acid VS until the color of the solution changes from purple through blue to greenish blue (indicator: 2 drops of crystal violet TS). Perform a blank determination in the same manner, and make any necessary correction.

Each mL of 0.1 mol/L perchloric acid VS
= 21.37 mg of $C_{10}H_{12}ClNO_2$

Containers and storage Containers—Well-closed containers.

Baclofen Tablets

バクロフェン錠

Baclofen Tablets contain not less than 93.0% and not more than 107.0% of the labeled amount of baclofen ($C_{10}H_{12}ClNO_2$: 213.66).

Method of preparation Prepare as directed under Tablets, with Baclofen.

Identification (1) To a portion of powdered Baclofen Tablets, equivalent to 0.01 g of Baclofen, add 10 mL of water, shake well, and filter. To 5 mL of the filtrate add 1 mL of ninhydrin TS, and proceed as directed in the Identification (1) under Baclofen.

(2) To a portion of powdered Baclofen Tablets, equivalent to 25 mg of Baclofen, add 50 mL of 0.1 mol/L hydrochloric acid TS, shake for 15 minutes, and filter. Determine the absorption spectrum of the filtrate as directed under Ultraviolet-visible Spectrophotometry <2.24>: it exhibits maxima between 257 nm and 261 nm, between 264 nm and 268 nm, and between 272 nm and 276 nm.

(3) To a portion of powdered Baclofen Tablets, equivalent to 0.01 g of Baclofen, add 2 mL of a mixture of methanol and acetic acid (100) (4:1), shake well, centrifuge, and use the supernatant liquid as the sample solution. Separately, dissolve 0.01 g of Baclofen RS in 2 mL of a mixture of methanol and acetic acid (100) (4:1), and use this solution as the standard solution. Perform the test with these solutions as directed under Thin-layer Chromatography <2.03>. Spot 20 μ L each of the sample solution and standard solution on a plate of silica gel with fluorescent indicator for thin-layer chromatography. Develop the plate with a mixture of 1-butanol, water and acetic acid (100) (4:1:1) to a distance of about 10 cm, and air-dry the plate. Examine under ultraviolet light (main wavelength: 254 nm): the spot from the sample solution and that from the standard solution show the same *R_f* value.

Uniformity of dosage units <6.02> Perform the test according to the following method: it meets the requirement of the Content uniformity test.

To 1 tablet of Baclofen Tablets add 5 mL of 0.1 mol/L hydrochloric acid TS, disperse the tablet into small particles by sonicating, then shake for 10 minutes, and add 0.1 mol/L hydrochloric acid TS to make exactly *V* mL so that each mL contains about 0.5 mg of baclofen ($C_{10}H_{12}ClNO_2$). Centri-

fuge, pipet 5 mL of the supernatant liquid, add 2 drops of phenolphthalein TS, neutralize with dilute sodium hydroxide TS, then add water to make exactly 50 mL, and use this solution as the sample solution. Separately, weigh accurately about 25 mg of Baclofen RS (separately determine the water <2.48> in the same manner as Baclofen), and dissolve in 0.1 mol/L hydrochloric acid TS to make exactly 50 mL. Pipet 5 mL of this solution, add 2 drops of phenolphthalein TS, neutralize with dilute sodium hydroxide TS, then add water to make exactly 50 mL, and use this solution as the standard solution. To exactly 2 mL each of the sample solution and standard solution add 4 mL of ninhydrin-tin (II) chloride TS, mix, heat on a water bath for 20 minutes, then immediately shake vigorously for 2 minutes. After cooling, add a mixture of water and 1-propanol (1:1) to make them exactly 25 mL, and determine the absorbances, *A_T* and *A_S*, of them at 570 nm as directed under Ultraviolet-visible Spectrophotometry <2.24>, using a solution obtained with 2 mL of water by the same procedure as above as the blank.

Amount (mg) of baclofen ($C_{10}H_{12}ClNO_2$)
= $M_S \times A_T/A_S \times V/50$

M_S: Amount (mg) of Baclofen RS taken, calculated on the anhydrous basis

Dissolution <6.10> When the test is performed at 50 revolutions per minute according to the Paddle method, using 500 mL of water as the dissolution medium, the dissolution rate in 45 minutes of Baclofen Tablets is not less than 70%.

Start the test with 1 tablet of Baclofen Tablets, withdraw not less than 20 mL of the medium at the specified minute after starting the test, and filter through a membrane filter with a pore size not exceeding 0.8 μ m. Discard not less than 10 mL of the first filtrate, pipet *V* mL of the subsequent, add water to make exactly *V'* mL so that each mL contains about 10 μ g of baclofen ($C_{10}H_{12}ClNO_2$), and use this solution as the sample solution. Separately, weigh accurately about 10 mg of Baclofen RS (separately determine the water <2.48> in the same manner as Baclofen), dissolve in water to make exactly 100 mL, then pipet 10 mL of this solution, add water to make exactly 100 mL, and use this solution as the standard solution. Determine the absorbances, *A_T* and *A_S*, of the sample solution and the standard solution at 220 nm as directed under Ultraviolet-visible Spectrophotometry <2.24>.

Dissolution rate (%) with respect to the labeled amount of baclofen ($C_{10}H_{12}ClNO_2$)
= $M_S \times A_T/A_S \times V'/V \times 1/C \times 50$

M_S: Amount (mg) of Baclofen RS taken, calculated on the anhydrous basis

C: Labeled amount (mg) of baclofen ($C_{10}H_{12}ClNO_2$) in 1 tablet

Assay Weigh accurately and powder not less than 20 Baclofen Tablets. Weigh accurately a portion of the powder, equivalent to about 50 mg of baclofen ($C_{10}H_{12}ClNO_2$), add 130 mL of 0.1 mol/L hydrochloric acid TS, shake for 10 minutes, add 0.1 mol/L hydrochloric acid TS to make exactly 200 mL, and centrifuge. Pipet 10 mL of the supernatant liquid, add 2 drops of phenolphthalein TS, neutralize with dilute sodium hydroxide TS, add water to make exactly 50 mL, and use this solution as the sample solution. Separately, weigh accurately about 0.25 g of Baclofen RS (separately determine the water content <2.48> in the same manner as Baclofen), and dissolve in 0.1 mol/L hydrochloric acid TS to make exactly 100 mL. Pipet 10 mL of this solution, and add 0.1 mol/L hydrochloric acid TS to make exactly 100 mL. Pipet 10 mL of this solution, add 2 drops of

phenolphthalein TS, neutralize with dilute sodium hydroxide TS, add water to make exactly 50 mL, and use this solution as the standard solution. Pipet 2 mL each of the sample solution and the standard solution, to each add 4 mL of ninhydrin-stannous chloride TS, shake, heat on a water bath for 20 minutes, and shake at once vigorously for 2 minutes. After cooling, to each solution add a mixture of water and 1-propanol (1:1) to make exactly 25 mL. Determine the absorbances, A_T and A_S , of these solutions at 570 nm as directed under Ultraviolet-visible Spectrophotometry <2.24>, using a blank prepared with 2 mL of water in the same manner.

$$\begin{aligned} \text{Amount (mg) of baclofen (C}_{10}\text{H}_{12}\text{ClNO}_2) \\ = M_S \times A_T / A_S \times 1/5 \end{aligned}$$

M_S : Amount (mg) of Baclofen RS taken, calculated on the anhydrous basis

Containers and storage Containers—Well-closed containers.

Bamethan Sulfate

バメタン硫酸塩

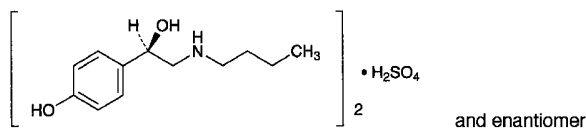

$(\text{C}_{12}\text{H}_{19}\text{NO}_2)_2 \cdot \text{H}_2\text{SO}_4$: 516.65
(1*RS*)-2-Butylamino-1-(4-hydroxyphenyl)ethanol hemisulfate
[5716-20-1]

Bamethan Sulfate, when dried, contains not less than 99.0% of bamethan sulfate [$(\text{C}_{12}\text{H}_{19}\text{NO}_2)_2 \cdot \text{H}_2\text{SO}_4$].

Description Bamethan Sulfate occurs as white, crystals or crystalline powder. It is odorless, and has a bitter taste.

It is freely soluble in water and in acetic acid (100), soluble in methanol, slightly soluble in ethanol (95), and practically insoluble in diethyl ether.

Melting point: about 169°C (with decomposition).

Identification (1) To 1 mL of a solution of Bamethan Sulfate (1 in 1000) add 5 mL of a solution of 4-nitrobenzenediazonium fluoroborate (1 in 2000) and 10 mL of boric acid-potassium chloride-sodium hydroxide buffer solution (pH 9.2): an orange-red color develops.

(2) Determine the absorption spectrum of a solution of Bamethan Sulfate in 0.01 mol/L hydrochloric acid TS (1 in 10,000) as directed under Ultraviolet-visible Spectrophotometry <2.24>, and compare the spectrum with the Reference Spectrum: both spectra exhibit similar intensities of absorption at the same wavelengths.

(3) Determine the infrared absorption spectrum of Bamethan Sulfate, previously dried, as directed in the potassium bromide disk method under Infrared Spectrophotometry <2.25>: it exhibits absorption at the wave numbers of about 1618, 1597, 1518, 1118 and 833 cm^{-1} .

(4) A solution of Bamethan Sulfate (1 in 100) responds to Qualitative Tests <1.09> for sulfate.

pH <2.54> Dissolve 1.0 g of Bamethan Sulfate in 10 mL of water: the pH of this solution is between 4.0 and 5.5.

Purity (1) Clarity and color of solution—Dissolve 1.0 g

of Bamethan Sulfate in 20 mL of water: the solution is clear, and has no more color than the following control solution.

Control solution: To 1.5 mL of Matching Fluid O add diluted hydrochloric acid (1 in 40) to make 200 mL.

(2) Chloride <1.03>—Perform the test with 3.5 g of Bamethan Sulfate. Prepare the control solution with 0.25 mL of 0.01 mol/L hydrochloric acid VS (not more than 0.002%).

(3) Heavy metals <1.07>—Proceed with 2.0 g of Bamethan Sulfate according to Method 1, and perform the test. Prepare the control solution with 2.0 mL of Standard Lead Solution (not more than 10 ppm).

(4) Arsenic <1.11>—Prepare the test solution with 1.0 g of Bamethan Sulfate according to Method 3, and perform the test (not more than 2 ppm).

(5) Related substances—Dissolve 0.10 g of Bamethan Sulfate in 2 mL of methanol, and use this solution as the sample solution. Pipet 1 mL of the sample solution, add methanol to make exactly 100 mL, and use this solution as the standard solution. Perform the test with these solutions as directed under Thin-layer Chromatography <2.03>. Spot 2 μL each of the sample solution and standard solution on a plate of silica gel for thin-layer chromatography. Develop the plate with a mixture of chloroform and methanol (7:2) in a developing vessel saturated with ammonia vapor to a distance of about 12 cm, and air-dry the plate. Spray evenly Dragendorff's TS for spraying on the plate, air-dry for 15 minutes, spray Dragendorff's TS for spraying again, then, after 1 minute, spray evenly a solution of sodium nitrite (1 in 20), and immediately put a glass plate on the plate. Examine the plate after 30 minutes: the spots other than the principal spot obtained from the sample solution are not more intense than the spot from the standard solution.

Loss on drying <2.41> Not more than 0.5% (1 g, 105°C, 4 hours).

Residue on ignition <2.44> Not more than 0.1% (1 g).

Assay Weigh accurately about 0.75 g of Bamethan Sulfate, previously dried, dissolve in 80 mL of acetic acid (100), and titrate with 0.1 mol/L perchloric acid VS (potentiometric titration). Perform a blank determination in the same manner, and make any necessary correction.

$$\begin{aligned} \text{Each mL of 0.1 mol/L perchloric acid VS} \\ = 51.67 \text{ mg of } (\text{C}_{12}\text{H}_{19}\text{NO}_2)_2 \cdot \text{H}_2\text{SO}_4 \end{aligned}$$

Containers and storage Containers—Tight containers.

Barbital

バルビタール

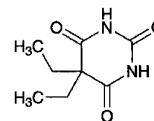

$\text{C}_8\text{H}_{12}\text{N}_2\text{O}_3$: 184.19
5,5-Diethylpyrimidine-2,4,6(1*H*,3*H*,5*H*)-trione
[57-44-3]

Barbital, when dried, contains not less than 99.0% of barbital ($\text{C}_8\text{H}_{12}\text{N}_2\text{O}_3$).

Description Barbital occurs as colorless or white crystals or a white crystalline powder. It is odorless, and has a slightly bitter taste.

It is freely soluble in acetone and in pyridine, soluble in ethanol (95), sparingly soluble in diethyl ether, and slightly soluble in water and in chloroform.

It dissolves in sodium hydroxide TS and in ammonia TS. The pH of its saturated solution is between 5.0 and 6.0.

Identification (1) Boil 0.2 g of Barbitol with 10 mL of sodium hydroxide TS: the gas evolved changes moistened red litmus paper to blue.

(2) Dissolve 0.05 g of Barbitol in 5 mL of diluted pyridine (1 in 10), add 0.3 mL of copper (II) sulfate TS, shake, and allow to stand for 5 minutes: a red-purple precipitate is formed. Shake the mixture with 5 mL of chloroform: a red-purple color develops in the chloroform layer. Separately, dissolve 0.05 g of Barbitol in 2 to 3 drops of ammonia-ammonium chloride buffer solution (pH 10.7) and 5 mL of diluted pyridine (1 in 10). Add 5 mL of chloroform and 0.3 mL of copper (II) sulfate TS to the solution: a red-purple precipitate is produced in the aqueous layer. The red-purple precipitate is not dissolved in the chloroform by shaking.

(3) To 0.4 g of Barbitol add 0.1 g of anhydrous sodium carbonate and 4 mL of water, shake, and add a solution of 0.3 g of 4-nitrobenzyl chloride in 7 mL of ethanol (95). Heat the mixture on a water bath under a reflux condenser for 30 minutes, and allow to stand for 1 hour. Collect the separated crystals, wash with 7 mL of sodium hydroxide TS and a small amount of water, recrystallize from a mixture of ethanol (95) and chloroform (1:1), and dry at 105°C for 30 minutes: the crystals melt <2.60> between 192°C and 196°C.

Melting point <2.60> 189 – 192°C

Purity (1) Clarity and color of solution—Dissolve 0.5 g of Barbitol in 5 mL of sodium hydroxide TS: the solution is clear and colorless.

(2) Chloride <1.03>—Dissolve 0.30 g of Barbitol in 20 mL of acetone, and add 6 mL of dilute nitric acid and water to make 50 mL. Perform the test using this solution as the test solution. Prepare the control solution as follows: take 0.30 mL of 0.01 mol/L hydrochloric acid VS, 20 mL of acetone and 6 mL of dilute nitric acid, and add water to make 50 mL (not more than 0.035%).

(3) Sulfate <1.14>—Dissolve 0.40 g of Barbitol in 20 mL of acetone, and add 1 mL of dilute hydrochloric acid and water to make 50 mL. Perform the test using this solution as the test solution. Prepare the control solution as follows: take 0.40 mL of 0.005 mol/L sulfuric acid VS, 20 mL of acetone, and 1 mL of dilute hydrochloric acid, and add water to make 50 mL (not more than 0.048%).

(4) Heavy metals <1.07>—Proceed with 1.0 g of Barbitol according to Method 2, and perform the test. Prepare the control solution with 2.0 mL of Standard Lead solution (not more than 20 ppm).

(5) Readily carbonizable substances <1.15>—Perform the test with 0.5 g of Barbitol. The solution is not more colored than Matching Fluid A.

Loss on drying <2.41> Not more than 1.0% (1 g, 105°C, 2 hours).

Residue on ignition <2.44> Not more than 0.1% (1 g).

Assay Weigh accurately about 0.4 g of Barbitol, previously dried, and dissolve in 5 mL of ethanol (95) and 50 mL of chloroform. Titrate <2.50> with 0.1 mol/L potassium hydroxide-ethanol VS until the color of the solution changes from yellow through light blue to purple (indicator: 1 mL of alizarin yellow GG-thymolphthalein TS). Perform a blank determination in the same manner, and make any necessary correction.

Each mL of 0.1 mol/L potassium hydroxide-ethanol VS = 18.42 mg of C₈H₁₂N₂O₃

Containers and storage Containers—Well-closed containers.

Barium Sulfate

硫酸バリウム

BaSO₄: 233.39

Description Barium Sulfate occurs as a white powder. It is odorless and tasteless.

It is practically insoluble in water, in ethanol (95) and in diethyl ether.

It does not dissolve in hydrochloric acid, in nitric acid and in sodium hydroxide TS.

Identification (1) Mix 0.5 g of Barium Sulfate with 2 g each of anhydrous sodium carbonate and potassium carbonate in a crucible, heat the mixture until fusion is complete, treat the cooled mass with hot water, and filter. The filtrate, acidified with hydrochloric acid, responds to Qualitative Tests <1.09> for sulfate.

(2) Wash the hot water-insoluble residue obtained in (1) with water, dissolve in 2 mL of acetic acid (31), and filter, if necessary: the solution responds to Qualitative Tests <1.09> for barium salt.

Purity (1) Acidity or alkalinity—Agitate 1.0 g of Barium Sulfate with 20 mL of water for 5 minutes: the solution is neutral.

(2) Phosphate—Boil 1.0 g of Barium Sulfate with 3 mL of nitric acid and 5 mL of water for 5 minutes, cool, and add water to restore the original volume. Filter through a filter paper, previously washed with dilute nitric acid, to the filtrate add an equal volume of hexaammonium heptamolybdate TS, and allow to stand between 50°C and 60°C for 1 hour: no yellow precipitate is produced.

(3) Sulfide—Place 10 g of Barium Sulfate in a 250-mL conical flask, add 10 mL of dilute hydrochloric acid and water to make 100 mL, and boil for 10 minutes: the gas evolved does not darken moistened lead (II) acetate paper.

(4) Heavy metals <1.07>—Boil 5.0 g of Barium Sulfate with 2.5 mL of acetic acid (100) and 50 mL of water for 10 minutes, cool, add 0.5 mL of ammonia TS and water to make 100 mL, and filter. Perform the test with a 50-mL portion of this filtrate. Prepare the control solution with 2.5 mL of Standard Lead Solution, 1.25 mL of acetic acid (100), 0.25 mL of ammonia TS and water to make 50 mL (not more than 10 ppm).

(5) Arsenic <1.11>—Prepare the test solution with 2.0 g of Barium Sulfate according to Method 1, and perform the test (not more than 1 ppm).

(6) Hydrochloric acid-soluble substances and soluble barium salts—Cool the solution obtained in (3), add water to make 100 mL, and filter. Evaporate 50 mL of the filtrate on a water bath to dryness, add 2 drops of hydrochloric acid and 10 mL of warm water, filter through a filter paper for quantitative analysis, and wash with 10 mL of warm water. Evaporate the combined filtrate and washings on a water bath to dryness, and dry the residue at 105°C for 1 hour: the residue weighs not more than 15 mg. Shake the residue, if any, with 10 mL of water, and filter. To the filtrate add 0.5 mL of dilute sulfuric acid, and allow to stand for 30 minutes: no turbidity is produced.

Containers and storage Containers—Well-closed containers.

Freeze-dried BCG Vaccine (for Percutaneous Use)

乾燥 BCG ワクチン

Freeze-dried BCG Vaccine (for Percutaneous Use) is a preparation for injection which is dissolved before use.

It contains live bacteria derived from a culture of the bacillus of Calmette and Guérin.

It conforms to the requirements of Freeze-dried BCG Vaccine (for Percutaneous Use) in the Minimum Requirements for Biological Products.

Description Freeze-dried BCG Vaccine (for Percutaneous Use) becomes a white to light yellow, turbid liquid on addition of solvent.

Beclometasone Dipropionate

ベクロメタゾンプロピオン酸エステル

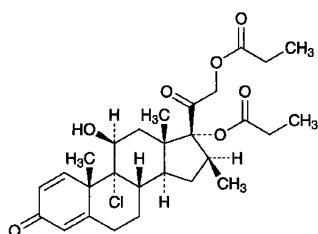

$C_{28}H_{37}ClO_7$: 521.04

9-Chloro-11 β ,17,21-trihydroxy-16 β -methylpregna-1,4-diene-3,20-dione 17,21-dipropionate
[5534-09-8]

Beclometasone Dipropionate, when dried, contains not less than 97.0% and not more than 103.0% of beclometasone dipropionate ($C_{28}H_{37}ClO_7$).

Description Beclometasone Dipropionate occurs as a white to pale yellow powder.

It is soluble in methanol, sparingly soluble in ethanol (99.5), and practically insoluble in water.

Melting point: about 208°C (with decomposition).

It shows crystal polymorphism.

Identification (1) Dissolve 2 mg of Beclometasone Dipropionate in 2 mL of sulfuric acid: initially a yellowish color develops, and gradually changes through orange to dark red-brown. To this solution add carefully 10 mL of water: the color changes to bluish green, and a flocculent precipitate is formed.

(2) Dissolve 0.01 g of Beclometasone Dipropionate in 1 mL of methanol, add 1 mL of Fehling's TS, and heat: a red to red-brown precipitate is formed.

(3) Perform the test with 0.02 g of Beclometasone Dipropionate as directed under Oxygen Flask Combustion Method <1.06>, using a mixture of 1 mL of sodium hydroxide TS and 20 mL of water as an absorbing liquid: the test solution responds to Qualitative Tests <1.09> for chloride.

(4) Determine the infrared absorption spectrum of Beclometasone Dipropionate, previously dried, as directed in

the potassium bromide disk method under Infrared Spectrophotometry <2.25>, and compare the spectrum with the Reference Spectrum or the spectrum of previously dried Beclometasone Dipropionate RS: both spectra exhibit similar intensities of absorption at the same wave numbers. If any difference appears between the spectra, dissolve Beclometasone Dipropionate and Beclometasone Dipropionate RS in ethanol (95), respectively, then evaporate the ethanol to dryness, and repeat the test on the residues.

Optical rotation <2.49> $[\alpha]_D^{25}$: +106 – +114° (after drying, 0.1 g, ethanol (99.5), 10 mL, 100 mm).

Purity (1) Heavy metals <1.07>—Proceed with 0.5 g of Beclometasone Dipropionate according to Method 2, and perform the test. Prepare the control solution with 1.5 mL of Standard Lead Solution (not more than 30 ppm).

(2) Related substances—Dissolve 20 mg of Beclometasone Dipropionate in 5 mL of a mixture of chloroform and methanol (9:1), and use this solution as the sample solution. Pipet 1 mL of the sample solution, add a mixture of chloroform and methanol (9:1) to make exactly 50 mL, and use this solution as the standard solution. Perform the test with these solutions as directed under Thin-layer Chromatography <2.03>. Spot 5 μ L each of the sample solution and standard solution on a plate of silica gel for thin-layer chromatography. Develop the plate with a mixture of 1,2-dichloroethane, methanol and water (475:25:1) to a distance of about 15 cm, and air-dry the plate. Spray evenly alkaline blue tetrazolium TS on the plate: the spots other than the principal spot obtained from the sample solution are not more intense than the spot from the standard solution.

Loss on drying <2.41> Not more than 0.5% (0.5 g, 105°C, 3 hours).

Residue on ignition <2.44> Not more than 0.1% (0.5 g).

Assay Weigh accurately about 20 mg each of Beclometasone Dipropionate and Beclometasone Dipropionate RS, previously dried, and dissolve each in methanol to make exactly 50 mL. Pipet 10 mL each of these solutions, add exactly 10 mL of the internal standard solution and methanol to make 50 mL, and use these solutions as the sample solution and the standard solution, respectively. Perform the test with 20 μ L each of the sample solution and standard solution as directed under Liquid Chromatography <2.01> according to the following conditions, and calculate the ratios, Q_T and Q_S , of the peak area of beclometasone dipropionate to that of the internal standard, respectively.

$$\text{Amount (mg) of beclometasone dipropionate (C}_{28}\text{H}_{37}\text{ClO}_7) = M_S \times Q_T / Q_S$$

M_S : Amount (mg) of Beclometasone Dipropionate RS taken

Internal standard solution—A solution of testosterone propionate in methanol (1 in 4000).

Operating conditions—

Detector: An ultraviolet absorption photometer (wavelength: 254 nm).

Column: A stainless steel column 4.6 mm in inside diameter and 20 cm in length, packed with octadecylsilanized silica gel for liquid chromatography (5 μ m in particle diameter).

Column temperature: A constant temperature of about 25°C.

Mobile phase: A mixture of acetonitrile and water (3:2).

Flow rate: Adjust so that the retention time of beclometasone dipropionate is about 6 minutes.

System suitability—

System performance: When the procedure is run with 20 μL of the standard solution under the above operating conditions, beclometasone dipropionate and the internal standard are eluted in this order with the resolution between these peaks being not less than 8.

System repeatability: When the test is repeated 6 times with 20 μL of the standard solution under the above operating conditions, the relative standard deviation of the ratios of the peak area of beclometasone dipropionate to that of the internal standard is not more than 1.0%.

Containers and storage Containers—Tight containers.

Bekanamycin Sulfate

ベカナマイシン硫酸塩

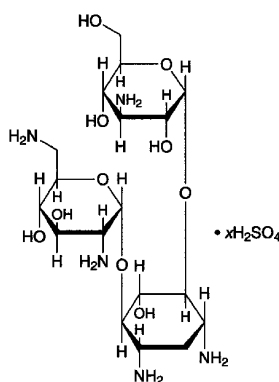

$$\text{C}_{18}\text{H}_{37}\text{N}_5\text{O}_{10} \cdot x\text{H}_2\text{SO}_4$$

3-Amino-3-deoxy- α -D-glucopyranosyl-(1 \rightarrow 6)-[2,6-diamino-2,6-dideoxy- α -D-glucopyranosyl-(1 \rightarrow 4)]-2-deoxy-D-streptomycin sulfate
[70550-99-1]

Bekanamycin Sulfate is the sulfate of an aminoglycoside substance having antibacterial activity produced by the growth of the mutant of *Streptomyces kanamyceticus*.

It contains not less than 680 μg (potency) and not more than 770 μg (potency) per mg, calculated on the dried basis. The potency of Bekanamycin Sulfate is expressed as mass (potency) of bekanamycin ($\text{C}_{18}\text{H}_{37}\text{N}_5\text{O}_{10}$; 483.51).

Description Bekanamycin Sulfate occurs as a white powder.

It is freely soluble in water, and practically insoluble in ethanol (99.5).

Identification (1) Dissolve 20 mg of Bekanamycin Sulfate in 2 mL of 1/15 mol/L phosphate buffer solution (pH 5.6), add 1 mL of ninhydrin TS, and boil: a blue-purple color develops.

(2) Dissolve 30 mg each of Bekanamycin Sulfate and Bekanamycin Sulfate RS in 5 mL of water, and use these solutions as the sample solution and standard solution. Perform the test with these solutions as directed under Thin-layer Chromatography <2.03>. Spot 5 μL each of the sample solution and standard solution on a plate of silica gel for thin-layer chromatography. Develop the plate with a solution of potassium dihydrogen phosphate (3 in 40) to a distance of about 10 cm, and air-dry the plate. Spray evenly 0.2% ninhydrin-water saturated 1-butanol TS on the plate, and heat the plate at 100°C for 10 minutes: the principal

spots obtained from the sample solution and the standard solution show a purple-brown color and the same R_f value.

(3) To a solution of Bekanamycin Sulfate (1 in 5) add 1 drop of barium chloride TS: a white turbidity is produced.

Optical rotation <2.49> $[\alpha]_D^{20}$: +102 – +116° (after drying, 0.25 g, water, 25 mL, 100 mm).

pH <2.54> The pH of a solution obtained by dissolving 0.50 g of Bekanamycin Sulfate in 10 mL of water is between 6.0 and 8.5.

Purity (1) Clarity and color of solution—Dissolve 0.5 g of Bekanamycin Sulfate in 5 mL of water: the solution is clear and colorless.

(2) Heavy metals <1.07>—Proceed with 1.0 g of Bekanamycin Sulfate according to Method 4, and perform the test. Prepare the control solution with 3.0 mL of Standard Lead Solution (not more than 30 ppm).

(3) Arsenic <1.11>—Prepare the test solution with 2.0 g of Bekanamycin Sulfate according to Method 1, and perform the test (not more than 1 ppm).

(4) Related substances—Dissolve 60 mg of Bekanamycin Sulfate in 10 mL of water, and use this solution as the sample solution. Pipet 3 mL of the sample solution, add water to make exactly 100 mL, and use this solution as the standard solution. Perform the test with these solutions as directed under Thin-layer Chromatography <2.03>. Spot 5 μL each of the sample solution and standard solution on a plate of silica gel for thin-layer chromatography. Develop the plate with a solution of potassium dihydrogen phosphate (3 in 40) to a distance of about 10 cm, and air-dry the plate. Spray evenly 0.2% ninhydrin-water saturated 1-butanol TS on the plate, and heat the plate at 100°C for 10 minutes: the spot other than the principal spot obtained from the sample solution is not more intense than the spot from the standard solution.

Loss on drying <2.41> Not more than 5.0% (0.5 g, reduced pressure not exceeding 0.67 kPa, 60°C, 3 hours).

Residue on ignition <2.44> Not more than 0.5% (1 g).

Assay Perform the test according to the Cylinder-plate method as directed under Microbial Assay for Antibiotics <4.02> according to the following conditions.

(i) Test organism—*Bacillus subtilis* ATCC 6632

(ii) Culture medium—Use the medium i in 1) under (1) Agar media for seed and base layer having pH <2.54> 7.8 to 8.0 after sterilization.

(iii) Standard solutions—Weigh accurately an amount of Bekanamycin Sulfate RS, previously dried, equivalent to about 20 mg (potency), dissolve in diluted phosphate buffer solution (pH 6.0) (1 in 2) to make exactly 50 mL, and use this solution as the standard stock solution. Keep the standard stock solution at 5 to 15°C and use within 30 days. Take exactly a suitable amount of the standard stock solution before use, add 0.1 mol/L phosphate buffer solution (pH 8.0) to make solutions so that each mL contains 10 μg (potency) and 2.5 μg (potency), and use these solutions as the high concentration standard solution and low concentration standard solution, respectively.

(iv) Sample solutions—Weigh accurately an amount of Bekanamycin Sulfate, equivalent to about 20 mg (potency), and dissolve in water to make exactly 50 mL. Take exactly a suitable amount of this solution, add 0.1 mol/L phosphate buffer solution (pH 8.0) to make solutions so that each mL contains 10 μg (potency) and 2.5 μg (potency), and use these solutions as the high concentration sample solution and low concentration sample solution, respectively.

Containers and storage Containers—Tight containers.

Benidipine Hydrochloride

ベニジピン塩酸塩

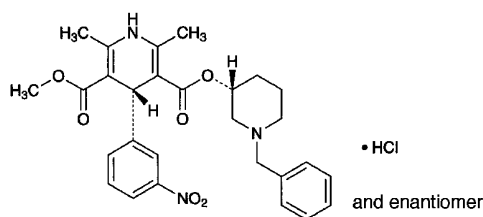

$C_{28}H_{31}N_3O_6 \cdot HCl$: 542.02

3-[(3*RS*)-1-Benzylpiperidin-3-yl] 5-methyl (4*RS*)-2,6-dimethyl-4-(3-nitrophenyl)-1,4-dihydropyridine-3,5-dicarboxylate monohydrochloride
[91599-74-5]

Benidipine Hydrochloride, when dried, contains not less than 99.0% and not more than 101.0% of benidipine hydrochloride ($C_{28}H_{31}N_3O_6 \cdot HCl$).

Description Benidipine Hydrochloride occurs as a yellow crystalline powder.

It is very soluble in formic acid, soluble in methanol, sparingly soluble in ethanol (99.5), and practically insoluble in water.

A solution of Benidipine Hydrochloride in methanol (1 in 100) shows no optical rotation.

Melting point: about 200°C (with decomposition).

Identification (1) Determine the absorption spectrum of a solution of Benidipine Hydrochloride in methanol (1 in 100,000) as directed under Ultraviolet-visible Spectrophotometry <2.24>, and compare the spectrum with the Reference Spectrum: both spectra exhibit similar intensities of absorption at the same wavelengths.

(2) Determine the infrared absorption spectrum of Benidipine Hydrochloride, previously dried, as directed in the potassium chloride disk method under Infrared Spectrophotometry <2.25>, and compare the spectrum with the Reference Spectrum: both spectra exhibit similar intensities of absorption at the same wave numbers.

(3) To 5 mL of a solution of Benidipine Hydrochloride (1 in 10) add 5 mL of ammonia TS, heat on a water bath for 5 minutes, cool, and filter. The filtrate, which is acidified with dilute nitric acid, responds to Qualitative Tests <1.09> (2) for chloride.

Purity (1) Heavy metals <1.07>—Proceed with 1.0 g of Benidipine Hydrochloride according to Method 2, and perform the test. Prepare the control solution with 2.0 mL of Standard Lead Solution (not more than 20 ppm).

(2) Related substances—Dissolve 20 mg of Benidipine Hydrochloride in 100 mL of a mixture of water and methanol (1:1), and use this solution as the sample solution. Pipet 1 mL of the sample solution, add the mixture of water and methanol (1:1) to make exactly 500 mL, and use this solution as the standard solution. Perform the test with exactly 10 μ L each of the sample solution and standard solution as directed under Liquid Chromatography <2.01> according to the following conditions, and determine each peak area by the automatic integration method: the peak areas of bisbenzylpiperidyl ester having the relative retention time of about 0.35 to benidipine, dehydro derivative having the relative

retention time of about 0.75 and other related substances obtained from the sample solution are not larger than 1/2 times the peak area of benidipine from the standard solution, and the total area of the peaks other than benidipine from the sample solution is not larger than the peak area of benidipine from the standard solution. For the areas of the peaks of bisbenzylpiperidyl ester and dehydro derivative, multiply their correction factor 1.6, respectively.

Operating conditions—

Detector: An ultraviolet absorption photometer (wavelength: 237 nm).

Column: A stainless steel column 4.6 mm in inside diameter and 10 cm in length, packed with octadecylsilanized silica gel for liquid chromatography (3 μ m in particle diameter).

Column temperature: A constant temperature of about 25°C.

Mobile phase: A mixture of 0.05 mol/L potassium dihydrogen phosphate TS (pH 3.0), methanol and tetrahydrofuran (65:27:8).

Flow rate: Adjust so that the retention time of benidipine is about 20 minutes.

Time span of measurement: About 2 times as long as the retention time of benidipine, beginning after the solvent peak.

System suitability—

Test for required detectability: Measure exactly 5 mL of the standard solution, and add the mixture of water and methanol (1:1) to make exactly 20 mL. Confirm that the peak area of benidipine obtained with 10 μ L of this solution is equivalent to 18 to 32% of that obtained with 10 μ L of the standard solution.

System performance: Dissolve 6 mg of Benidipine Hydrochloride and 5 mg of benzoin in 200 mL of the mixture of water and methanol (1:1). When the procedure is run with 10 μ L of this solution under the above operating conditions, benzoin and benidipine are eluted in this order with the resolution between these peaks being not less than 8.

System repeatability: When the test is repeated 6 times with 10 μ L of the standard solution under the above operating conditions, the relative standard deviation of the peak area of benidipine is not more than 3.5%.

Loss on drying <2.41> Not more than 0.5% (0.5 g, 105°C, 2 hours).

Residue on ignition <2.44> Not more than 0.1% (1 g).

Assay Weigh accurately about 0.7 g of Benidipine Hydrochloride, previously dried, dissolve in 10 mL of formic acid, add 70 mL of acetic anhydride, and titrate <2.50> with 0.1 mol/L perchloric acid VS (potentiometric titration). Perform a blank determination in the same manner, and make any necessary correction.

Each mL of 0.1 mol/L perchloric acid VS
= 54.20 mg of $C_{28}H_{31}N_3O_6 \cdot HCl$

Containers and storage Containers—Tight containers.

Benidipine Hydrochloride Tablets

ベニジピン塩酸塩錠

Benidipine Hydrochloride Tablets contain not less than 95.0% and not more than 105.0% of the labeled amount of benidipine hydrochloride ($C_{28}H_{31}N_3O_6 \cdot HCl$: 542.02).

Method of preparation Prepare as directed under Tablets, with Benidipine Hydrochloride.

Identification Shake well a quantity of powdered Benidipine Hydrochloride Tablets, equivalent to 10 mg of Benidipine Hydrochloride, with 100 mL of methanol, and centrifuge. To 10 mL of the supernatant liquid add methanol to make 100 mL, and use this solution as the sample solution. Determine the absorption spectrum of the sample solution as directed under Ultraviolet-visible Spectrophotometry <2.24>: it exhibits maxima between 235 nm and 239 nm, and between 350 nm and 360 nm.

Purity Dehydro derivative—Powder Benidipine Hydrochloride Tablets in an agate mortar. To an amount of the powder, equivalent to 20 mg of Benidipine Hydrochloride, add about 80 mL of a mixture of diluted phosphoric acid (1 in 500) and methanol (1:1), shake well, and add the mixture of diluted phosphoric acid (1 in 500) and methanol (1:1) to make exactly 100 mL. Filter through a membrane filter with pore size of 0.45 μm , and use the filtrate as the sample solution. Separately, dissolve 20 mg of benidipine hydrochloride for assay in the mixture of diluted phosphoric acid (1 in 500) and methanol (1:1) to make exactly 100 mL. Pipet 1 mL of this solution, add the mixture of diluted phosphoric acid (1 in 500) and methanol (1:1) to make exactly 100 mL, and use this solution as the standard solution. Perform the test with exactly 10 μL each of the sample solution and standard solution as directed under Liquid Chromatography <2.01> according to the following conditions, and determine each peak area by the automatic integration method: the peak area of dehydro derivative having the relative retention time of about 0.75 to benidipine obtained from the sample solution is not larger than 1/2 times the peak area of benidipine from the standard solution. For the area of the peak of dehydro derivative, multiply the correction factor 1.6.

Operating conditions—

Perform as directed in the operating conditions in the Assay.

System suitability—

Test for required detectability: Measure exactly 2 mL of the standard solution, and add the mixture of diluted phosphoric acid (1 in 500) and methanol (1:1) to make exactly 20 mL. Confirm that the peak area of benidipine obtained with 10 μL of this solution is equivalent to 7 to 13% of that with 10 μL of the standard solution.

System performance: Dissolve 6 mg of benidipine hydrochloride and 5 mg of benzoin in 200 mL of a mixture of water and methanol (1:1). When the procedure is run with 10 μL of this solution under the above operating conditions, benzoin and benidipine are eluted in this order with the resolution between these peaks being not less than 8.

System repeatability: When the test is repeated 6 times with 10 μL of the standard solution under the above operating conditions, the relative standard deviation of the peak area of benidipine is not more than 2.0%.

Uniformity of dosage units <6.02> Perform the test according to the following method: it meets the requirement of the Content uniformity test.

To 1 tablet of Benidipine Hydrochloride Tablets add 40 mL of a mixture of diluted phosphoric acid (1 in 500) and methanol (1:1), shake to disintegrate, and add a suitable amount of the mixture of diluted phosphoric acid (1 in 500) and methanol (1:1) to make exactly V mL of a solution, containing 40 μg of benidipine hydrochloride ($\text{C}_{28}\text{H}_{31}\text{N}_3\text{O}_6\cdot\text{HCl}$) per mL. Centrifuge the solution, pipet 20 mL of the supernatant liquid, add exactly 10 mL of the internal standard solu-

tion and the mixture of diluted phosphoric acid (1 in 500) and methanol (1:1) to make 50 mL, and use this solution as the sample solution. Then, proceed as directed in the Assay.

$$\begin{aligned} & \text{Amount (mg) of benidipine hydrochloride} \\ & (\text{C}_{28}\text{H}_{31}\text{N}_3\text{O}_6\cdot\text{HCl}) \\ & = M_S \times Q_T/Q_S \times V/1000 \end{aligned}$$

M_S : Amount (mg) of benidipine hydrochloride for assay taken

Internal standard solution—A solution of benzoin in a mixture of water and methanol (1:1) (13 in 200,000).

Dissolution <6.10> When the test is performed at 50 revolutions per minute according to the Paddle method using the sinker, using 900 mL of 1st fluid for dissolution test as the dissolution medium, the dissolution rate of a 2-mg tablet and a 4-mg tablet in 30 minutes is not less than 80%, and that of a 8-mg tablet in 45 minutes is not less than 85%.

Start the test with 1 tablet of Benidipine Hydrochloride Tablets, withdraw not less than 20 mL of the medium at the specified minute after starting the test, and filter through a membrane filter with a pore size not exceeding 0.45 μm . Discard not less than 10 mL of the first filtrate, pipet the subsequent V mL, and add the dissolution medium to make exactly V' mL so that each mL contains about 2.2 μg of benidipine hydrochloride ($\text{C}_{28}\text{H}_{31}\text{N}_3\text{O}_6\cdot\text{HCl}$). Pipet 5 mL of this solution, add exactly 5 mL of the mobile phase, and use this solution as the sample solution. Separately, weigh accurately about 22 mg of benidipine hydrochloride for assay, previously dried at 105°C for 2 hours, and dissolve in the mobile phase to make exactly 100 mL. Pipet 2 mL of this solution, and add the mobile phase to make exactly 50 mL. Pipet 5 mL of this solution, and add the mobile phase to make exactly 20 mL. Pipet 5 mL of this solution, add exactly 5 mL of the dissolution medium, and use this solution as the standard solution. Perform the test with exactly 50 μL each of the sample solution and standard solution as directed under Liquid Chromatography <2.01> according to the following conditions, and determine the peak areas, A_T and A_S , of benidipine in each solution.

$$\begin{aligned} & \text{Dissolution rate (\%)} \text{ of benidipine hydrochloride} \\ & (\text{C}_{28}\text{H}_{31}\text{N}_3\text{O}_6\cdot\text{HCl}) \text{ with respect to the labeled amount} \\ & = M_S \times A_T/A_S \times V'/V \times 1/C \times 9 \end{aligned}$$

M_S : Amount (mg) of benidipine hydrochloride for assay taken

C : Labeled amount (mg) of benidipine hydrochloride ($\text{C}_{28}\text{H}_{31}\text{N}_3\text{O}_6\cdot\text{HCl}$) in 1 tablet.

Operating conditions—

Detector: An ultraviolet absorption photometer (wavelength: 237 nm).

Column: A stainless steel column 4.6 mm in inside diameter and 15 cm in length, packed with octadecylsilanized silica gel for liquid chromatography (5 μm in particle diameter).

Column temperature: A constant temperature of about 25°C.

Mobile phase: A mixture of 0.05 mol/L potassium dihydrogen phosphate TS (pH 3.0) and acetonitrile (11:9).

Flow rate: Adjust so that the retention time of benidipine is about 5 minutes.

System suitability—

System performance: When the procedure is run with 50 μL of the standard solution under the above operating conditions, the number of theoretical plates and the symmetry factor of the peak of benidipine are not less than 3000 and not more than 2.0, respectively.

System repeatability: When the test is repeated 6 times with 50 μL of the standard solution under the above operating conditions, the relative standard deviation of the peak area of benidipine is not more than 1.5%.

Assay Weigh accurately the mass of not less than 20 Benidipine Hydrochloride Tablets, and powder using an agate mortar. Weigh accurately a part of the powder, equivalent to about 8 mg of benidipine hydrochloride ($\text{C}_{28}\text{H}_{31}\text{N}_3\text{O}_6 \cdot \text{HCl}$), add about 150 mL of a mixture of diluted phosphoric acid (1 in 500) and methanol (1:1), shake, then add the mixture of diluted phosphoric acid (1 in 500) and methanol (1:1) to make exactly 200 mL, and centrifuge. Pipet 20 mL of the supernatant liquid, add exactly 10 mL of the internal standard solution and the mixture of diluted phosphoric acid (1 in 500) and methanol (1:1) to make 50 mL, and use this solution as the sample solution. Separately, weigh accurately about 40 mg of benidipine hydrochloride for assay, previously dried at 105°C for 2 hours, and dissolve in the mixture of diluted phosphoric acid (1 in 500) and methanol (1:1) to make exactly 100 mL. Pipet 2 mL of this solution, add exactly 10 mL of the internal standard solution and the mixture of diluted phosphoric acid (1 in 500) and methanol (1:1) to make 50 mL, and use this solution as the standard solution. Perform the test with 10 μL each of the sample solution and standard solution as directed under Liquid Chromatography <2.01> according to the following conditions, and calculate the ratios, Q_T and Q_S , of the peak area of benidipine to that of the internal standard.

$$\begin{aligned} & \text{Amount (mg) of benidipine hydrochloride} \\ & (\text{C}_{28}\text{H}_{31}\text{N}_3\text{O}_6 \cdot \text{HCl}) \\ & = M_S \times Q_T/Q_S \times 1/5 \end{aligned}$$

M_S : Amount (mg) of benidipine hydrochloride for assay taken

Internal standard solution—A solution of benzoin in a mixture of water and methanol (1:1) (13 in 200,000).

Operating conditions—

Detector: An ultraviolet absorption photometer (wavelength: 237 nm).

Column: A stainless steel column 4.6 mm in inside diameter and 10 cm in length, packed with octadecylsilanized silica gel for liquid chromatography (3 μm in particle diameter).

Column temperature: A constant temperature of about 25°C.

Mobile phase: A mixture of 0.05 mol/L potassium dihydrogen phosphate TS (pH 3.0), methanol and tetrahydrofuran (65:27:8).

Flow rate: Adjust so that the retention time of benidipine is about 20 minutes.

System suitability—

System performance: When the procedure is run with 10 μL of the standard solution under the above operating conditions, the internal standard and benidipine are eluted in this order with the resolution between these peaks being not less than 8.

System repeatability: When the test is repeated 6 times with 10 μL of the standard solution under the above operating conditions, the relative standard deviation of the ratio of the peak area of benidipine to that of the internal standard is not more than 1.0%.

Containers and storage Containers—Well-closed containers.

Benserazide Hydrochloride

ベンセラジド塩酸塩

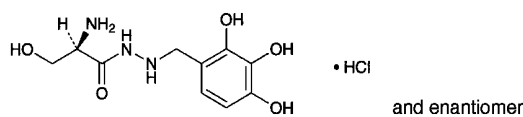

$\text{C}_{10}\text{H}_{15}\text{N}_3\text{O}_5 \cdot \text{HCl}$: 293.70
(2*RS*)-2-Amino-3-hydroxy-*N'*-(2,3,4-trihydroxybenzyl)propanoylhydrazone monohydrochloride
[14919-77-8]

Benserazide Hydrochloride contains not less than 98.0% and not more than 101.0% of benserazide hydrochloride ($\text{C}_{10}\text{H}_{15}\text{N}_3\text{O}_5 \cdot \text{HCl}$), calculated on the anhydrous basis.

Description Benserazide Hydrochloride occurs as a white to grayish white crystalline powder.

It is freely soluble in water and in formic acid, soluble in methanol, very slightly soluble in ethanol (95).

It dissolves in 0.1 mol/L hydrochloric acid TS.

The pH of a solution of 1.0 g of Benserazide Hydrochloride in 100 mL of water is between 4.0 and 5.0.

It is hygroscopic.

It is gradually colored by light.

A solution of Benserazide Hydrochloride (1 in 100) shows no optical rotation.

Identification (1) Determine the absorption spectrum of a solution of Benserazide Hydrochloride in 0.1 mol/L hydrochloric acid TS (1 in 10,000) as directed under Ultraviolet-visible Spectrophotometry <2.24>, and compare the spectrum with the Reference Spectrum: both spectra exhibit similar intensities of absorption at the same wavelengths.

(2) Determine the infrared absorption spectrum of Benserazide Hydrochloride as directed in the potassium chloride disk method under Infrared Spectrophotometry <2.25>, and compare the spectrum with the Reference Spectrum: both spectra exhibit similar intensities of absorption at the same wave numbers.

(3) To 10 mL of a solution of Benserazide Hydrochloride (1 in 30) add silver nitrate TS: a white precipitate is formed. To a portion of this precipitate add dilute nitric acid: the precipitation does not dissolve.

Purity (1) Clarity and color of solution—Dissolve 0.5 g of Benserazide Hydrochloride in 10 mL of water, and perform the test with this solution as directed under Ultraviolet-visible Spectrophotometry <2.24>: the absorbance of this solution at 430 nm is not more than 0.10.

(2) Heavy metals <1.07>—Proceed with 1.0 g of Benserazide Hydrochloride according to Method 2, and perform the test. Prepare the control solution with 2.0 mL of Standard Lead Solution (not more than 20 ppm).

(3) Related substances—Conduct this procedure without exposure to light, using light-resistant vessels. Dissolve 0.25 g of Benserazide Hydrochloride in 10 mL of methanol, and use this solution as the sample solution. Pipet 1 mL and 3 mL of the sample solution, add methanol to make exactly 200 mL, and use these solutions as the standard solution (1) and (2), respectively. Perform the test with these solutions as directed under Thin-layer Chromatography <2.03>. Spot 2 μL each of the sample solution and standard solutions (1) and (2) on a plate of cellulose for thin-layer chromatogra-

phy. Develop the plate with a solution of formic acid in sodium chloride TS (1 in 1000) to a distance of about 10 cm, and air-dry the plate. Spray evenly sodium carbonate TS, air-dry, and then spray evenly Folin's TS on the plate: the spots other than the principal spot obtained from the sample solution are not more intense than the spot from the standard solution (2), and the number of the spots which intense more than the spot from the standard solution (1) are not more than 2.

Water <2.48> Not more than 2.5% (0.5 g, volumetric titration, direct titration). Use a solution of salicylic acid in methanol for water determination (3 in 20) instead of methanol for water determination.

Residue on ignition <2.44> Not more than 0.1% (1 g).

Assay Weigh accurately about 0.3 g of Benserazide Hydrochloride, dissolve in 5 mL of formic acid, add 50 mL of acetic acid (100), and titrate <2.50> immediately with 0.1 mol/L perchloric acid VS (potentiometric titration). Perform a blank determination in the same manner, and make any necessary correction.

Each mL of 0.1 mol/L perchloric acid VS
= 29.37 mg of $C_{10}H_{15}N_3O_5 \cdot HCl$

Containers and storage Containers—Tight containers.
Storage—Light-resistant.

Bentonite

ベントナイト

Bentonite is a natural, colloidal, hydrated aluminum silicate.

Description Bentonite occurs as a very fine, white to light yellow-brown powder. It is odorless. It has a slightly earthy taste.

It is practically insoluble in water, in ethanol (95) and in diethyl ether.

It swells in water.

Identification (1) Add 0.5 g of Bentonite to 3 mL of diluted sulfuric acid (1 in 3), and heat until white fumes are evolved. Cool, add 20 mL of water, and filter. To 5 mL of the filtrate add 3 mL of ammonia TS: a white, gelatinous precipitate is produced, which turns red on the addition of 5 drops of alizarin red S TS.

(2) Wash the residue obtained in (1) with water, add 2 mL of a solution of methylene blue trihydrate (1 in 10,000), and wash again with water: the residue is blue in color.

pH <2.54> To 1.0 g of Bentonite add 50 mL of water, and shake: the pH of the suspension is between 9.0 and 10.5.

Purity (1) Heavy metals <1.07>—To 1.5 g of Bentonite add 80 mL of water and 5 mL of hydrochloric acid, and boil gently for 20 minutes with thorough stirring. Cool, centrifuge, collect the supernatant liquid, wash the residue with two 10-mL portions of water, and centrifuge each. Combine the supernatant liquid and the washings, and add dropwise ammonia solution (28). When a precipitate is produced, add dropwise dilute hydrochloric acid with vigorous stirring, and dissolve. To the solution add 0.45 g of hydroxylammonium chloride, and heat. Cool, and add 0.45 g of sodium acetate trihydrate, 6 mL of dilute acetic acid and water to make 150 mL. Pipet 50 mL of the solution, and perform the test using this solution as the test solution. Prepare the control solution

as follows: mix 2.5 mL of Standard Lead Solution, 0.15 g of hydroxylammonium chloride, 0.15 g of sodium acetate trihydrate, and 2 mL of dilute acetic acid, and add water to make 50 mL (not more than 50 ppm).

(2) Arsenic <1.11>—To 1.0 g of Bentonite add 5 mL of dilute hydrochloric acid, and gently heat to boil while stirring well. Cool immediately, and centrifuge. To the residue add 5 mL of dilute hydrochloric acid, shake well, and centrifuge. To the residue add 10 mL of water, and perform the same operations. Combine all the extracts, and heat on a water bath to concentrate to 5 mL. Perform the test with this solution as the test solution (not more than 2 ppm).

(3) Foreign matter—Place 2.0 g of Bentonite in a mortar, add 20 mL of water to swell, disperse evenly with a pestle, and dilute with water to 100 mL. Pour the suspension through a No. 200 (74 μ m) sieve, and wash the sieve thoroughly with water. No grit is felt when the fingers are rubbed over the wire mesh of the sieve.

Loss on drying <2.41> 5.0 – 10.0% (2 g, 105°C, 2 hours).

Gel formation Mix 6.0 g of Bentonite with 0.30 g of magnesium oxide. Add the mixture, in several portions, to 200 mL of water contained in a glass-stoppered 500-mL cylinder. Agitate for 1 hour, transfer 100 mL of the suspension to a 100-mL graduated cylinder, and allow to stand for 24 hours: not more than 2 mL of supernatant appears on the surface.

Swelling power To 100 mL of water in a glass-stoppered 100-mL cylinder add 2.0 g of Bentonite in ten portions, allowing each portion to settle before adding the next, and allow to stand for 24 hours: the apparent volume of the sediment at the bottom is not less than 20 mL.

Containers and storage Containers—Well-closed containers.

Benzalkonium Chloride

ベンザルコニウム塩化物

Benzalkonium Chloride is represented by the formula $[C_6H_5CH_2N(CH_3)_2R]Cl$, in which R extends from C_8H_{17} to $C_{18}H_{37}$, with $C_{12}H_{25}$ and $C_{14}H_{29}$ comprising the major portion.

It contains not less than 95.0% and not more than 105.0% of benzalkonium chloride (as $C_{22}H_{40}ClN$: 354.01), calculated on the anhydrous basis.

Description Benzalkonium Chloride occurs as a white to yellow-white powder, colorless to light yellow, gelatinous pieces, or jelly-like fluid or mass. It has a characteristic odor.

It is very soluble in water and in ethanol (95), and practically insoluble in diethyl ether.

A solution of Benzalkonium Chloride foams strongly when shaken.

Identification (1) Dissolve 0.2 g of Benzalkonium Chloride in 1 mL of sulfuric acid, add 0.1 g of sodium nitrate, and heat for 5 minutes on a water bath. After cooling, add 10 mL of water and 0.5 g of zinc powder, heat for 5 minutes, cool, and filter: the filtrate responds to Qualitative Tests <1.09> for primary aromatic amines. The color of the solution is red.

(2) To 2 mL of a solution of Benzalkonium Chloride (1 in 1000) add a mixture of 0.2 mL of a solution of bromophenol blue (1 in 2000) and 0.5 mL of sodium hydroxide TS: a

blue color develops. Add 4 mL of chloroform to this solution, and shake vigorously: the blue color shifts to the chloroform layer. Collect the chloroform layer, and add dropwise, with stirring, a solution of sodium lauryl sulfate (1 in 1000): the chloroform layer turns colorless.

(3) Determine the absorption spectrum of a solution of Benzalkonium Chloride in 0.1 mol/L hydrochloric acid TS (1 in 2000) as directed under Ultraviolet-visible Spectrophotometry <2.24>, and compare the spectrum with the Reference Spectrum: both spectra exhibit similar intensities of absorption at the same wavelengths.

(4) To 1 mL of a solution of Benzalkonium Chloride (1 in 100) add 2 mL of ethanol (95), 0.5 mL of dilute nitric acid and 1 mL of silver nitrate TS: a white precipitate is produced. This precipitate does not dissolve on the addition of dilute nitric acid, but dissolves on the addition of ammonia TS.

Purity (1) Clarity and color of solution—Dissolve 1.0 g of Benzalkonium Chloride in 10 mL of water: the solution is clear and colorless to light yellow.

(2) Petroleum ether-soluble substances—To 3.0 g of Benzalkonium Chloride add water to make 50 mL, then add 50 mL of ethanol (99.5) and 5 mL of 0.5 mol/L sodium hydroxide TS, and extract with three 50-mL portions of petroleum ether. Combine the petroleum ether extracts, and wash with three 50-mL portions of dilute ethanol. After shaking well with 10 g of anhydrous sodium sulfate, filter through a dry filter paper, and wash the filter paper with two 10-mL portions of petroleum ether. Evaporate the petroleum ether on a water bath by heating, and dry the residue at 105°C for 1 hour: the residue is not more than 1.0%.

Water <2.48> Not more than 15.0% (volumetric titration, direct titration).

Residue on ignition <2.44> Not more than 0.2% (1 g).

Assay Weigh accurately about 0.15 g of Benzalkonium Chloride, and dissolve in 75 mL of water. Adjust the pH between 2.6 and 3.4 by adding dropwise diluted dilute hydrochloric acid (1 in 2), add 1 drop of methyl orange TS, and titrate <2.50> with 0.02 mol/L sodium tetraphenylboron VS until the color of the solution becomes red.

Each mL of 0.02 mol/L sodium tetraphenylboron VS
= 7.080 mg of C₂₂H₄₀CIN

Containers and storage Containers—Tight containers.

Benzalkonium Chloride Solution

ベンザルコニウム塩化物液

Benzalkonium Chloride Solution is an aqueous solution containing not more than 50.0 w/v% of benzalkonium chloride.

It contains not less than 93.0% and not more than 107.0% of the labeled amount of benzalkonium chloride (C₂₂H₄₀CIN: 354.01).

Method of preparation Dissolve Benzalkonium Chloride in Water, Purified Water or Purified Water in Containers. It is also prepared by diluting Concentrated Benzalkonium Chloride Solution 50 with Water, Purified Water or Purified Water in Containers.

Description Benzalkonium Chloride Solution is a clear, colorless to light yellow liquid, having a characteristic odor.

It foams strongly on shaking.

Identification (1) Evaporate a volume of Benzalkonium Chloride Solution, equivalent to 0.2 g of Benzalkonium Chloride, on a water bath to dryness, and proceed with the residue as directed in the Identification (1) under Benzalkonium Chloride.

(2) To a volume of Benzalkonium Chloride Solution, equivalent to 0.01 g of Benzalkonium Chloride, add water to make 10 mL. Proceed with 2 mL of this solution as directed in the Identification (2) under Benzalkonium Chloride.

(3) To a volume of Benzalkonium Chloride Solution, equivalent to 1 g of Benzalkonium Chloride, add water or concentrate on a water bath, if necessary, to make 10 mL. To 1 mL of this solution add 0.1 mol/L hydrochloric acid VS to make 200 mL, and proceed as directed in the Identification (3) under Benzalkonium Chloride.

(4) To a volume of Benzalkonium Chloride Solution, equivalent to 0.1 g of Benzalkonium Chloride, add water or concentrate on a water bath, if necessary, to make 10 mL. Proceed with 1 mL of this solution as directed in the Identification (4) under Benzalkonium Chloride.

Assay Pipet a volume of Benzalkonium Chloride Solution, equivalent to about 0.15 g of benzalkonium chloride (C₂₂H₄₀CIN), dilute with water to make 75 mL, if necessary, and proceed as directed in the Assay under Benzalkonium Chloride.

Each mL of 0.02 mol/L sodium tetraphenylboron VS
= 7.080 mg of C₂₂H₄₀CIN

Containers and storage Containers—Tight containers.

Benzalkonium Chloride Concentrated Solution 50

濃ベンザルコニウム塩化物液 50

Benzalkonium Chloride Concentrated Solution 50 is an aqueous solution, presented as [C₆H₅CH₂N(CH₃)₂R]Cl, where R ranges from C₈H₁₇ to C₁₈H₃₇, and mainly consisting of C₁₂H₂₅ and C₁₄H₂₉.

It contains more than 50.0% and not more than 55.0% of benzalkonium chloride (C₂₂H₄₀CIN: 354.01).

Description Benzalkonium Chloride Concentrated Solution 50 is a colorless to light yellow liquid or jelly-like fluid, and has a characteristic odor.

It is very soluble in water and in ethanol (95), and practically insoluble in diethyl ether.

A solution prepared by adding water to it vigorously foams when shaken.

Identification (1) Dissolve 0.4 g of Benzalkonium Chloride Concentrated Solution 50 in 1 mL of sulfuric acid, add 0.1 g of sodium nitrate, and heat for 5 minutes on a water bath. After cooling, add 10 mL of water and 0.5 g of zinc powder, heat for 5 minutes, cool, and filter: the filtrate responds to Qualitative Tests <1.09> for primary aromatic amines. The color of the solution is red.

(2) To 2 mL of a solution of Benzalkonium Chloride Concentrated Solution 50 (1 in 500) add a mixture of 0.2 mL of a solution of bromophenol blue (1 in 2000) and 0.5 mL of sodium hydroxide TS: a blue color develops. Add 4 mL of chloroform to this solution, and shake vigorously: the blue color shifts to the chloroform layer. Collect the chloroform layer, and add dropwise, with stirring, a solution of sodium

lauryl sulfate (1 in 1000): the chloroform layer turns colorless.

(3) Determine the absorption spectrum of a solution of Benzalkonium Chloride Concentrated Solution 50 in 0.1 mol/L hydrochloric acid TS (1 in 1000) as directed under Ultraviolet-visible Spectrophotometry <2.24>, and compare the spectrum with the Reference Spectrum of Benzalkonium Chloride: both spectra exhibit similar intensities of absorption at the same wavelengths.

(4) To 1 mL of a solution of Benzalkonium Chloride Concentrated Solution 50 (1 in 50) add 2 mL of ethanol (95), 0.5 mL of dilute nitric acid and 1 mL of silver nitrate TS: a white precipitate is produced. This precipitate does not dissolve on the addition of dilute nitric acid, but dissolves on the addition of ammonia TS.

Purity (1) Clarity and color of solution—Dissolve 2.0 g of Benzalkonium Chloride Concentrated Solution 50 in 10 mL of water: the solution is clear and colorless to light yellow.

(2) Petroleum ether-soluble substances—To 6.0 g of Benzalkonium Chloride Concentrated Solution 50 add water to make 50 mL, then add 50 mL of ethanol (99.5) and 5 mL of 0.5 mol/L sodium hydroxide TS, and extract with three 50-mL portions of petroleum ether. Combine the petroleum ether extracts, and wash with three 50-mL portions of dilute ethanol. After shaking well with 10 g of anhydrous sodium sulfate, filter through a dry filter paper, and wash the filter paper with two 10-mL portions of petroleum ether. Evaporate the petroleum ether on a water bath by heating, and dry the residue at 105°C for 1 hour: the residue is not more than 1.0%.

Residue on ignition <2.44> Not more than 0.2% (1 g).

Assay Weigh accurately about 0.3 g of Benzalkonium Chloride Concentrated Solution 50, and dissolve in 75 mL of water. Adjust the pH to between 2.6 and 3.4 by adding dropwise diluted dilute hydrochloric acid (1 in 2), add 1 drop of methyl orange TS, and titrate <2.50> with 0.02 mol/L sodium tetraphenylboron VS until the color of the solution becomes red.

Each mL of 0.02 mol/L sodium tetraphenylborate VS
= 7.080 mg of C₂₂H₄₀ClN

Containers and storage Containers—Tight containers.

Benzbromarone

ベンズブロマロン

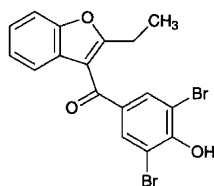

C₁₇H₁₂Br₂O₃: 424.08

3,5-Dibromo-4-hydroxyphenyl 2-ethylbenzo[*b*]furan-3-yl ketone

[3562-84-3]

Benzbromarone, when dried, contains not less than 98.5% and not more than 101.0% of benzbromarone (C₁₇H₁₂Br₂O₃).

Description Benzbromarone occurs as a white to light yellow

low crystalline powder.

It is very soluble in *N,N*-dimethylformamide, freely soluble in acetone, sparingly soluble in ethanol (99.5), and practically insoluble in water.

It dissolves in dilute sodium hydroxide TS.

Identification (1) Determine the absorption spectrum of a solution of Benzbromarone in 0.01 mol/L sodium hydroxide TS (1 in 100,000) as directed under Ultraviolet-visible Spectrophotometry <2.24>, and compare the spectrum with the Reference Spectrum: both spectra exhibit similar intensities of absorption at the same wavelengths.

(2) Determine the infrared absorption spectrum of Benzbromarone, previously dried, as directed in the potassium bromide disk method under Infrared Spectrophotometry <2.25>, and compare the spectrum with the Reference Spectrum: both spectra exhibit similar intensities of absorption at the same wave numbers.

Melting point <2.60> 149 – 153°C

Purity (1) Sulfate <1.14>—Dissolve 1.0 g of Benzbromarone in 40 mL of acetone, and add 1 mL of dilute hydrochloric acid and water to make 50 mL. Perform the test using this solution as the test solution. Prepare the control solution as follows: to 0.40 mL of 0.005 mol/L sulfuric acid VS add 40 mL of acetone, 1 mL of dilute hydrochloric acid and water to make 50 mL (not more than 0.019%).

(2) Soluble halides—Dissolve 0.5 g of Benzbromarone in 40 mL of acetone, and add 6 mL of dilute nitric acid and water to make 50 mL. Proceed with this solution as directed under Chloride Limit Test <1.03>. Prepare the control solution as follows: to 0.25 mL of 0.01 mol/L hydrochloric acid VS add 40 mL of acetone, 6 mL of dilute nitric acid and water to make 50 mL.

(3) Heavy metals <1.07>—Proceed with 2.0 g of Benzbromarone according to Method 2, and perform the test. Prepare the control solution with 2.0 mL of Standard Lead Solution (not more than 10 ppm).

(4) Iron <1.10>—Prepare the test solution with 1.0 g of Benzbromarone according to Method 3, and perform the test according to Method A. Prepare the control solution with 2.0 mL of Standard Iron Solution (not more than 20 ppm).

(5) Related substances—Dissolve 0.10 g of Benzbromarone in 10 mL of acetone, and use this solution as the sample solution. Pipet 1 mL of the sample solution, add acetone to make exactly 100 mL, and use this solution as the standard solution. Perform the test with these solutions as directed under Thin-layer Chromatography <2.03>. Spot 10 μL each of the sample solution and standard solution on a plate of silica gel with fluorescent indicator for thin-layer chromatography. Develop the plate with a mixture of cyclohexane, 4-methyl-2-pentanone, ethanol (99.5) and acetic acid (100) (100:20:2:1) to a distance of about 15 cm, and air-dry the plate. Examine under ultraviolet light (main wavelength: 254 nm): the spots other than the principal spot obtained from the sample solution are not more intense than the spot from the standard solution.

Loss on drying <2.41> Not more than 0.5% (1 g, in vacuum at a pressure not exceeding 0.67 kPa, phosphorus (V) oxide, 50°C, 4 hours).

Residue on ignition <2.44> Not more than 0.1% (1 g).

Assay Weigh accurately about 0.6 g of Benzbromarone, previously dried, dissolve in 30 mL of *N,N*-dimethylformamide, and titrate <2.50> with 0.1 mol/L tetramethylammonium hydroxide VS (indicator: 5 drops of thymol blue dimethylformamide TS). Perform a blank determination in

the same manner, and make any necessary correction.

Each mL of 0.1 mol/L tetramethylammonium hydroxide VS
= 42.41 mg of $C_{17}H_{12}Br_2O_3$

Containers and storage Containers—Tight containers.
Storage—Light-resistant.

Benzethonium Chloride

ベンゼトニウム塩化物

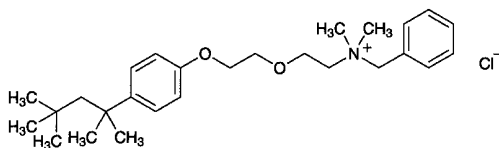

$C_{27}H_{42}ClNO_2$: 448.08

N-Benzyl-*N,N*-dimethyl-2-{2-[4-(1,1,3,3-tetramethylbutyl)phenoxy]ethoxy}ethylammonium chloride
[121-54-0]

Benzethonium Chloride, when dried, contains not less than 97.0% of benzethonium chloride ($C_{27}H_{42}ClNO_2$).

Description Benzethonium Chloride occurs as colorless or white crystals. It is odorless.

It is very soluble in ethanol (95), freely soluble in water, and practically insoluble in diethyl ether.

A solution of Benzethonium Chloride foams strongly when shaken.

Identification (1) Dissolve 0.2 g of Benzethonium Chloride in 1 mL of sulfuric acid, add 0.1 g of sodium nitrate, and heat for 5 minutes on a water bath. After cooling, add 10 mL of water and 0.5 g of zinc powder, heat for 5 minutes, cool, and filter: the filtrate responds to Qualitative Tests <1.09> for primary aromatic amines, developing a red color.

(2) To 2 mL of a solution of Benzethonium Chloride (1 in 1000) add a mixture of 0.2 mL of a solution of bromophenol blue (1 in 2000) and 0.5 mL of sodium hydroxide TS: a blue color develops. Add 4 mL of chloroform to this solution, and shake vigorously: the blue color shifts to the chloroform layer. Collect the chloroform layer, and add dropwise a solution of sodium lauryl sulfate (1 in 1000) with stirring: the chloroform layer turns colorless.

(3) Determine the absorption spectrum of a solution of Benzethonium Chloride in 0.1 mol/L hydrochloric acid TS (1 in 5000) as directed under Ultraviolet-visible Spectrophotometry <2.24>, and compare the spectrum with the Reference Spectrum: both spectra exhibit similar intensities of absorption at the same wavelengths.

(4) To 1 mL of a solution of Benzethonium Chloride (1 in 100) add 2 mL of ethanol (95), 0.5 mL of dilute nitric acid and 1 mL of silver nitrate TS: a white precipitate is produced. This precipitate does not dissolve on addition of dilute nitric acid, but dissolves on addition of ammonia TS.

Melting point <2.60> 158 – 164°C (after drying).

Purity Ammonium—Dissolve 0.10 g of Benzethonium Chloride in 5 mL of water, and boil with 3 mL of sodium hydroxide TS: the evolving gas does not change moistened red litmus paper to blue.

Loss on drying <2.41> Not more than 5.0% (1 g, 105°C,

4 hours).

Residue on ignition <2.44> Not more than 0.1% (1 g).

Assay Weigh accurately about 0.2 g of Benzethonium Chloride, previously dried, dissolve in 75 mL of water, add diluted dilute hydrochloric acid (1 in 2) dropwise to adjust the pH to 2.6–3.4, then add 1 drop of methyl orange TS, and titrate <2.50> with 0.02 mol/L tetraphenylboron VS until the solution develops a red.

Each mL of 0.02 mol/L sodium tetraphenylboron VS
= 8.962 mg of $C_{27}H_{42}ClNO_2$

Containers and storage Containers—Tight containers.
Storage—Light-resistant.

Benzethonium Chloride Solution

ベンゼトニウム塩化物液

Benzethonium Chloride Solution contains not less than 93.0% and not more than 107.0% of the labeled amount of benzethonium chloride ($C_{27}H_{42}ClNO_2$: 448.08).

Method of preparation Dissolve Benzethonium Chloride in Water, Purified Water or Purified Water in Containers.

Description Benzethonium Chloride Solution is a clear, colorless liquid. It is odorless.

It foams strongly when shaken.

Identification (1) Evaporate a volume of Benzethonium Chloride Solution, equivalent to 0.2 g of Benzethonium Chloride, on a water bath to dryness, and proceed with the residue as directed in the Identification (1) under Benzethonium Chloride.

(2) To a volume of Benzethonium Chloride Solution, equivalent to 0.01 g of Benzethonium Chloride, add water to make 10 mL, proceed with 2 mL of this solution as directed in the Identification (2) under Benzethonium Chloride.

(3) To a volume of Benzethonium Chloride Solution, equivalent to 1 g of Benzethonium Chloride, and add water or concentrate on a water bath to make 10 mL. To 1 mL of this solution add 0.1 mol/L hydrochloric acid TS to make 500 mL, and determine the absorption spectrum as directed under Ultraviolet-visible Spectrophotometry <2.24>: it exhibits its maxima between 262 nm and 264 nm, between 268 nm and 270 nm, and between 274 nm and 276 nm.

(4) To a volume of Benzethonium Chloride Solution, equivalent to 0.1 g of Benzethonium Chloride, add water, or concentrate on a water bath, if necessary, to make 10 mL, and proceed with 1 mL of this solution as directed in the Identification (4) under Benzethonium Chloride.

Purity (1) Nitrite—Add 1.0 mL of Benzethonium Chloride Solution to a mixture of 1 mL of a solution of glycine (1 in 10) and 0.5 mL of acetic acid (31): no gas is evolved.

(2) Oxidizing substances—To 5 mL of Benzethonium Chloride Solution add 0.5 mL of potassium iodide TS and 2 to 3 drops of dilute hydrochloric acid: no yellow color is produced.

Assay Pipet a volume of Benzethonium Chloride Solution, equivalent to about 0.2 g of benzethonium chloride ($C_{27}H_{42}ClNO_2$), dilute with water to make 75 mL, if necessary, and proceed as directed in the Assay under Benzethonium Chloride.

Each mL of 0.02 mol/L sodium tetraphenylboron VS
= 8.962 mg of $C_{27}H_{42}ClNO_2$

Containers and storage Containers—Tight containers.
Storage—Light-resistant.

Benzoic Acid

安息香酸

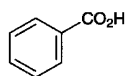

$C_7H_6O_2$: 122.12
Benzoic acid
[65-85-0]

Benzoic Acid, when dried, contains not less than 99.5% of benzoic acid ($C_7H_6O_2$).

Description Benzoic Acid occurs as white, crystals or crystalline powder. It is odorless, or has a faint, benzaldehyde-like odor.

It is freely soluble in ethanol (95), in acetone and in diethyl ether, soluble in hot water, and slightly soluble in water.

Identification Dissolve 1 g of Benzoic Acid in 8 mL of sodium hydroxide TS, and add water to make 100 mL. This solution responds to Qualitative Tests <1.09> (2) for benzoate.

Melting point <2.60> 121 – 124°C

Purity (1) Heavy metals <1.07>—Dissolve 1.0 g of Benzoic Acid in 25 mL of acetone, add 2 mL of dilute acetic acid and water to make 50 mL, and perform the test using this solution as the test solution. Prepare the control solution as follows: to 2.0 mL of Standard Lead Solution add 2 mL of dilute acetic acid, 25 mL of acetone and water to make 50 mL (not more than 20 ppm).

(2) Chlorinated compounds—Take 0.5 g of Benzoic Acid and 0.7 g of calcium carbonate in a crucible, mix with a small amount of water, and dry. Ignite it at about 600°C, dissolve in 20 mL of dilute nitric acid, and filter. Wash the residue with 15 mL of water, combine the filtrate and the washing, add water to make 50 mL, and add 0.5 mL of silver nitrate TS: this solution has not more turbid than the following control solution.

Control solution: Dissolve 0.7 g of calcium carbonate in 20 mL of dilute nitric acid, and filter. Wash the residue with 15 mL of water, combine the filtrate and the washings, add 1.2 mL of 0.01 mol/L hydrochloric acid VS and water to make 50 mL, and add 0.5 mL of silver nitrate TS.

(3) Potassium permanganate-reducing substances—Add 0.02 mol/L potassium permanganate VS dropwise to a boiling mixture of 100 mL of water and 1.5 mL of sulfuric acid, until a red color persists for 30 seconds. Dissolve 1.0 g of Benzoic Acid in this boiling solution, and add 0.50 mL of 0.02 mol/L potassium permanganate VS: a red color persists for at least 15 seconds.

(4) Phthalic acid—To 0.10 g of Benzoic Acid add 1 mL of water and 1 mL of resorcinol-sulfuric acid TS, and heat the mixture in an oil bath heated at a temperature between 120°C and 125°C. After evaporating the water, heat the residue for 90 minutes, cool, and dissolve in 5 mL of water. To 1 mL of the solution add 10 mL of a solution of sodium hydroxide (43 in 500), shake, then examine under light at a wavelength between 470 nm and 490 nm: the green fluores-

cence of the solution is not more intense than that of the following control solution.

Control solution: Dissolve 61 mg of potassium hydrogen phthalate in water to make exactly 1000 mL. Measure exactly 1 mL of the solution, add 1 mL of resorcinol-sulfuric acid TS, and proceed as directed above.

(5) Readily carbonizable substances <1.15>—Perform the test with 0.5 g of Benzoic Acid. The solution is not more colored than Matching Fluid Q.

Loss on drying <2.41> Not more than 0.5% (1 g, silica gel, 3 hours).

Residue on ignition <2.44> Not more than 0.05% (1 g).

Assay Weigh accurately about 0.5 g of Benzoic Acid, previously dried, dissolve in 25 mL of neutralized ethanol and 25 mL of water, and titrate <2.50> with 0.1 mol/L sodium hydroxide VS (indicator: 3 drops of phenolphthalein TS).

Each mL of 0.1 mol/L sodium hydroxide VS
= 12.21 mg of $C_7H_6O_2$

Containers and storage Containers—Well-closed containers.

Benzyl Alcohol

ベンジルアルコール

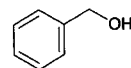

C_7H_8O : 108.14
Benzyl alcohol
[100-51-6]

This monograph is harmonized with the European Pharmacopoeia and the U.S. Pharmacopoeia.

The parts of the text that are not harmonized are marked with symbols (◆ ◆).

Information on the harmonization with the European Pharmacopoeia and the U.S. Pharmacopoeia is available on the website of the Pharmaceuticals and Medical Devices Agency.

Benzyl Alcohol contains not less than 98.0% and not more than 100.5% of benzyl alcohol (C_7H_8O).

◆The label states, where applicable, that it is suitable for use in the manufacture of injection forms.◆

◆**Description** Benzyl Alcohol is a clear, colorless oily liquid.

It is miscible with ethanol (95), with fatty oils and with essential oils.

It is soluble in water.

Specific gravity d_{20}^{20} : 1.043 – 1.049◆

◆**Identification** Determine the infrared absorption spectrum of Benzyl Alcohol as directed in the liquid film method under Infrared Spectrophotometry <2.25>, and compare the spectrum with the Reference Spectrum: both spectra exhibit similar intensities of absorption at the same wave numbers.◆

Refractive index <2.45> n_D^{20} : 1.538 – 1.541

Purity ◆(1) Clarity and color of solution—Dissolve 2.0 mL of Benzyl Alcohol in 60 mL of water: the solution is clear and colorless.◆

(2) Acidity—To 10 mL of Benzyl Alcohol add 10 mL of ethanol (95) and 2 drops of phenolphthalein TS, and add

dropwise 0.1 mol/L sodium hydroxide VS until the solution acquires a light red color: the amount of 0.1 mol/L sodium hydroxide VS used is not more than 1.0 mL.

(3) Benzaldehyde and other related substances—Use Benzyl Alcohol as the sample solution. Separately, dissolve exactly 0.100 g of ethylbenzene in Benzyl Alcohol to make exactly 10 mL. Pipet 2 mL of this solution, add Benzyl Alcohol to make exactly 20 mL, and use this solution as the ethylbenzene stock solution. Separately, dissolve exactly 2.000 g of dicyclohexyl in Benzyl Alcohol to make exactly 10 mL. Pipet 2 mL of this solution, add Benzyl Alcohol to make exactly 20 mL, and use this solution as the dicyclohexyl stock solution. Separately, weigh exactly 0.750 g of benzaldehyde and 0.500 g of cyclohexylmethanol, and add Benzyl Alcohol to make exactly 25 mL. Pipet 1 mL of this solution, add exactly 2 mL of ethylbenzene stock solution and exactly 3 mL of dicyclohexyl stock solution, then add Benzyl Alcohol to make exactly 20 mL, and use this solution as the standard solution (1). Perform the test with exactly 0.1 μ L each of the sample solution and standard solution (1) as directed under Gas Chromatography <2.02> according to the following conditions, and when the peak having the retention time corresponding to ethylbenzene and dicyclohexyl appears on the chromatogram obtained from the sample solution, correct the peak areas of ethylbenzene and dicyclohexyl from the standard solution (1) by deducting the relevant peak area from the sample solution, the peak area of benzaldehyde from the sample solution is not more than the difference between the peak areas of benzaldehyde of the sample solution and the standard solution (1) (0.15%), and the peak area of cyclohexylmethanol from the sample solution is not more than the difference between the peak areas of cyclohexylmethanol of the sample solution and the standard solution (1) (0.10%). The total area of the peaks having smaller retention time than benzyl alcohol and other than benzaldehyde and cyclohexylmethanol from the sample solution is not more than 4 times the peak area or the corrected peak area of ethylbenzene from the standard solution (1) (0.04%). The total area of the peaks having larger retention time than benzyl alcohol from the sample solution is not more than the peak area or the corrected peak area of dicyclohexyl from the standard solution (1) (0.3%). For these calculations the peak areas less than 1/100 times the peak area or the corrected peak area of ethylbenzene with the standard solution (1) are excluded.

Benzyl Alcohol labeled that it is suitable for use in the manufacture of injection forms meets the following requirements.

Use Benzyl Alcohol as the sample solution. Separately, weigh exactly 0.250 g of benzaldehyde and 0.500 g of cyclohexylmethanol, and add Benzyl Alcohol to make exactly 25 mL. Pipet 1 mL of this solution, add exactly 2 mL of the ethylbenzene stock solution and exactly 2 mL of the dicyclohexyl stock solution, then add Benzyl Alcohol to make exactly 20 mL, and use this solution as the standard solution (2). Perform the test with exactly 0.1 μ L each of the sample solution and standard solution (2) as directed under Gas Chromatography <2.02> according to the following conditions, and when the peak having the retention time corresponding to ethylbenzene and dicyclohexyl appears on the chromatogram obtained from the sample solution, correct the peak areas of ethylbenzene and dicyclohexyl from the standard solution (2) by deducting the relevant peak area from the sample solution, the peak area of benzaldehyde from the sample solution is not more than the difference between the peak areas of benzaldehyde of the sample solution and the standard solution (2) (0.05%), and the peak area of

cyclohexylmethanol from the sample solution is not more than the difference between the peak areas of cyclohexylmethanol of the sample solution and the standard solution (2) (0.10%). The total area of the peaks having smaller retention time than benzyl alcohol and other than benzaldehyde and cyclohexylmethanol from the sample solution is not more than 2 times the peak area or the corrected peak area of ethylbenzene from the standard solution (2) (0.02%). The total area of the peaks having larger retention time than benzyl alcohol from the sample solution is not more than the peak area of or the corrected peak area dicyclohexyl from the standard solution (2) (0.2%). For these calculation the peak areas less than 1/100 times the peak area or the corrected peak area of ethylbenzene from the standard solution (2) are excluded.

Operating conditions—

Detector: A hydrogen flame-ionization detector.

Column: A fused silica column 0.32 mm in inside diameter and 30 m in length, coated inside with polyethylene glycol 20 M for gas chromatography in 0.5 μ m thickness.

Column temperature: Inject at a constant temperature of about 50°C, raise the temperature at a rate of 5°C per minute to 220°C, and maintain at 220°C for 35 minutes.

Temperature of injection port: A constant temperature of about 200°C.

Temperature of detector: A constant temperature of about 310°C.

Carrier gas: Helium.

Flow rate: 25 cm/second.

Splitless.

Detection sensitivity: When 0.1 μ L of the standard solution (1) is injected, adjust the sensitivity of the detector so that the height of the peak of ethylbenzene is not less than 30% of the full scale of the recorder. For Benzyl Alcohol labeled to use for injection, use the standard solution (2) instead of the standard solution (1).

System suitability—

System performance: When the procedure is run with the standard solution (1) under the above operating conditions, the retention time of benzyl alcohol is about 26 minutes, the relative retention times of ethylbenzene, dicyclohexyl, benzaldehyde and cyclohexylmethanol to benzyl alcohol are about 0.28, about 0.59, about 0.68 and about 0.71, respectively, and the resolution between the peaks of benzaldehyde and cyclohexylmethanol is not less than 3.0. In the case of Benzyl Alcohol labeled to use for injection, proceed with the standard solution (2) instead of the standard solution (1).

(4) Peroxide value—Weigh accurately about 5 g of Benzyl Alcohol, and dissolve in 30 mL of a mixture of acetic acid (100) and chloroform (3:2) in a 250-mL glass-stoppered conical flask. Add 0.5 mL of saturated potassium iodide solution, shake for exactly 1 minute, add 30 mL of water, and titrate <2.50> with 0.01 mol/L sodium thiosulfate VS, adding the titrant slowly with continuous vigorous shaking, until the blue color of the solution disappears after addition of 5 mL of starch TS near the end point where the solution is a pale yellow color. Perform a blank determination in the same manner. Calculate the amount of peroxide by the following formula: not more than 5. In the blank determination, the required amount of 0.01 mol/L sodium thiosulfate VS must not exceed 0.1 mL.

$$\text{Amount (mEq/kg) of peroxide} = 10 \times (V_1 - V_0)/M$$

V_1 : Volume (mL) of 0.01 mol/L sodium thiosulfate VS consumed in the test

V_0 : Volume (mL) of 0.01 mol/L sodium thiosulfate VS consumed in the blank determination

M: Amount (g) of Benzyl Alcohol taken

(5) Residue on evaporation—Perform the test after conformation that the sample meets the requirement of the peroxide value. Transfer 10.0 g of Benzyl Alcohol to a porcelain or quartz crucible or platinum dish, previously weighed accurately, and heat on a hot-plate at not exceeding 200°C, taking care to avoid boiling, to evaporate to dryness. Dry the residue on the hot-plate for 1 hour, and allow to cool in a desiccator: not more than 5 mg.

Assay Weigh accurately about 0.9 g of Benzyl Alcohol, add exactly 15 mL of a freshly prepared mixture of dehydrated pyridine and acetic anhydride (7:1), and heat on a water bath under a reflux condenser for 30 minutes. Cool, add 25 mL of water, and titrate <2.50> the excess acetic acid with 1 mol/L sodium hydroxide VS (indicator: 2 drops of phenolphthalein TS). Perform a blank determination in the same manner.

Each mL of 1 mol/L sodium hydroxide VS
= 108.1 mg of C₇H₈O

◆**Containers and storage** Containers—Tight containers.
Storage—Light-resistant.◆

Benzyl Benzoate

安息香酸ベンジル

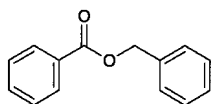

C₁₄H₁₂O₂: 212.24
Benzyl benzoate
[120-51-4]

Benzyl Benzoate contains not less than 99.0% of benzyl benzoate (C₁₄H₁₂O₂).

Description Benzyl Benzoate is a colorless, clear, viscous liquid. It has a faint, aromatic odor and a pungent, burning taste.

It is miscible with ethanol (95) and with diethyl ether.

It is practically insoluble in water.

Congealing point: about 17°C

Specific gravity *d*₂₀²⁰: about 1.123

Boiling point: about 323°C

Identification (1) Heat gently 1 mL of Benzyl Benzoate with 5 mL of sodium carbonate TS and 2 mL of potassium permanganate TS: the odor of benzaldehyde is perceptible.

(2) Warm the titrated mixture obtained in the Assay on a water bath to remove ethanol, and add 0.5 mL of iron (III) chloride TS: a light yellow-red precipitate is produced, which turns white on the addition of dilute hydrochloric acid.

Refractive index <2.45> *n*_D²⁰: 1.568 – 1.570

Purity Acidity—Dissolve 5.0 mL of Benzyl Benzoate in 25 mL of neutralized ethanol, and add 0.50 mL of 0.1 mol/L sodium hydroxide VS: a red color develops.

Residue on ignition <2.44> Not more than 0.05% (2 g).

Assay Weigh accurately about 2 g of Benzyl Benzoate, add exactly 50 mL of 0.5 mol/L potassium hydroxide-ethanol VS, and boil gently for 1 hour under a reflux condenser with a carbon dioxide-absorbing tube (soda lime). Cool, and titrate <2.50> the excess potassium hydroxide with 0.5 mol/L

hydrochloric acid VS (indicator: 2 drops of phenolphthalein TS). Perform a blank determination in the same manner.

Each mL of 0.5 mol/L potassium hydroxide-ethanol VS
= 106.1 mg of C₁₄H₁₂O₂

Containers and storage Containers—Tight containers.
Storage—Light-resistant.

Benzylpenicillin Benzathine Hydrate

ベンジルペニシリンベンザチン水和物

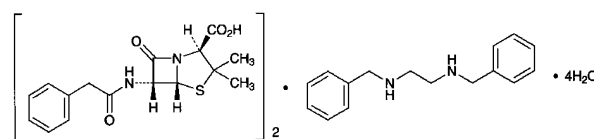

(C₁₆H₁₈N₂O₄S)₂·C₁₆H₂₀N₂·4H₂O: 981.18
(2*S*,5*R*,6*R*)-3,3-Dimethyl-7-oxo-6-[(phenylacetyl)amino]-4-thia-1-azabicyclo[3.2.0]heptane-2-carboxylic acid hemi(*N,N'*-dibenzylethane-1,2-diamine)dihydrate [41372-02-5]

Benzylpenicillin Benzathine Hydrate is the *N,N'*-dibenzylethylenediamine salt of a penicillin compound having antibacterial activity produced by the growth of *Penicillium* species.

It contains not less than 1213 Units and not more than 1333 Units per mg, calculated on the anhydrous basis. The potency of Benzylpenicillin Benzathine Hydrate is expressed as unit calculated from the amount of benzylpenicillin sodium (C₁₆H₁₇N₂NaO₄S: 356.37). 1 Unit of Benzylpenicillin Benzathine Hydrate is equivalent to 0.6 μg of benzylpenicillin sodium (C₁₆H₁₇N₂NaO₄S). It contains not less than 24.0% and not more than 27.0% of *N,N'*-dibenzylethylenediamine (C₁₆H₂₀N₂: 240.34), calculated on the anhydrous basis.

Description Benzylpenicillin Benzathine Hydrate occurs as a white crystalline powder.

It is slightly soluble in methanol and in ethanol (99.5), and practically insoluble in water.

Identification (1) Determine the absorption spectrum of a solution of Benzylpenicillin Benzathine Hydrate in methanol (1 in 2000) as directed under Ultraviolet-visible Spectrophotometry <2.24>, and compare the spectrum with the Reference Spectrum: both spectra exhibit similar intensities of absorption at the same wavelengths.

(2) Determine the infrared absorption spectrum of Benzylpenicillin Benzathine Hydrate as directed in the potassium bromide disk method under Infrared Spectrophotometry <2.25>, and compare the spectrum with the Reference Spectrum: both spectra exhibit similar intensities of absorption at the same wave numbers.

Optical rotation <2.49> [*α*]_D²⁰: +217 – +233° (0.1 g calculated on the anhydrous basis, methanol, 20 mL, 100 mm).

Purity (1) Heavy metals <1.07>—Proceed with 1.0 g of Benzylpenicillin Benzathine Hydrate according to Method 2, and perform the test. Prepare the control solution with 2.0 mL of Standard Lead Solution (not more than 20 ppm).

(2) Arsenic <1.11>—Prepare the test solution with 1.0 g of Benzylpenicillin Benzathine Hydrate according to Method 3, and perform the test (not more than 2 ppm).

(3) Related substances—Dissolve 70 mg of Benzylpenicillin Benzathine Hydrate in 25 mL of methanol, add a solution prepared by dissolving 1.02 g of disodium hydrogen phosphate and 6.80 g of potassium dihydrogen phosphate in water to make 1000 mL to make 50 mL, and use this solution as the sample solution. Pipet 1 mL of the sample solution, add the mobile phase A to make exactly 100 mL, and use this solution as the standard solution. Perform the test with exactly 20 μ L each of the sample solution and standard solution as directed under Liquid Chromatography <2.01> according to the following conditions, and determine each peak area by the automatic integration method: the area of the peak having the relative retention time of about 2.4 to benzylpenicillin obtained from the sample solution is not larger than 2 times the total area of the peaks of benzylpenicillin and *N,N'*-dibenzylethylenediamine from the standard solution, and the area of the peak other than benzylpenicillin, *N,N'*-dibenzylethylenediamine and the peak having the relative retention time of about 2.4 to benzylpenicillin from the sample solution is not larger than the total area of the peaks of benzylpenicillin and *N,N'*-dibenzylethylenediamine from the standard solution.

Operating conditions—

Detector: An ultraviolet absorption photometer (wavelength: 220 nm).

Column: A stainless steel column 4.0 mm in inside diameter and 25 cm in length, packed with octadecylsilanized silica gel for liquid chromatography (5 μ m in particle diameter).

Column temperature: A constant temperature of about 40°C.

Mobile phase A: A mixture of water, methanol and 0.25 mol/L potassium dihydrogen phosphate TS (pH 3.5) (6:3:1).

Mobile phase B: A mixture of methanol, water and 0.25 mol/L potassium dihydrogen phosphate TS (pH 3.5) (6:3:1).

Flowing of mobile phase: Control the gradient by mixing the mobile phases A and B as directed in the following table.

Time after injection of sample (min)	Mobile phase A (vol%)	Mobile phase B (vol%)
0 - 10	75	25
10 - 20	75 \rightarrow 0	25 \rightarrow 100
20 - 55	0	100

Flow rate: 1.0 mL per minute.

Time span of measurement: About 3 times as long as the retention time of benzylpenicillin, beginning after the solvent peak.

System suitability—

Test for required detectability: To exactly 1 mL of the standard solution add the mobile phase A to make exactly 20 mL. Confirm that the peak area of benzylpenicillin obtained with 20 μ L of this solution is equivalent to 3.5 to 6.5% of that with 20 μ L of the standard solution.

System performance: When the procedure is run with 20 μ L of the standard solution under the above operating conditions, *N,N'*-dibenzylethylenediamine and benzylpenicillin are eluted in this order with the resolution between these peaks being not less than 25.

System repeatability: When the test is repeated 3 times with 20 μ L of the standard solution under the above operating conditions, the relative standard deviation of the peak areas of benzylpenicillin is not more than 2.0%.

Water <2.48> 5.0 - 8.0% (1 g, volumetric titration, direct titration).

Assay (1) Benzylpenicillin—Weigh accurately an amount of Benzylpenicillin Benzathine Hydrate, equivalent to about 85,000 Units, dissolve in 25 mL of methanol, and add a solution containing 1.02 g of disodium hydrogen phosphate and 6.80 g of potassium dihydrogen phosphate in 1000 mL of water to make exactly 50 mL. Pipet 5 mL of this solution, add a mixture of the solution containing 1.02 g of disodium hydrogen phosphate and 6.80 g of potassium dihydrogen phosphate in 1000 mL of water and methanol (1:1) to make exactly 20 mL, and use this solution as the sample solution. Separately, weigh accurately an amount of Benzylpenicillin Potassium RS, equivalent to about 85,000 Units, and about 25 mg of *N,N'*-dibenzylethylenediamine diacetate, dissolve in 25 mL of methanol, and add the solution containing 1.02 g of disodium hydrogen phosphate and 6.80 g of potassium dihydrogen phosphate in 1000 mL of water to make exactly 50 mL. Pipet 5 mL of this solution, add a mixture of the solution containing 1.02 g of disodium hydrogen phosphate and 6.80 g of potassium dihydrogen phosphate in 1000 mL of water and methanol (1:1) to make exactly 20 mL, and use this solution as the standard solution. Perform the test with exactly 20 μ L each of the sample solution and standard solution as directed under Liquid Chromatography <2.01> according to the following conditions, and determine the peak areas, A_T and A_S , of benzylpenicillin in each solution.

Amount (unit) of benzylpenicillin sodium ($C_{16}H_{17}N_2NaO_4S$)
 $= M_S \times A_T / A_S$

M_S : Amount (unit) of Benzylpenicillin Potassium RS taken

Operating conditions—

Detector: An ultraviolet absorption photometer (wavelength: 220 nm).

Column: A stainless steel column 4.6 mm in inside diameter and 25 cm in length, packed with octadecylsilanized silica gel for liquid chromatography (5 μ m in particle diameter).

Column temperature: A constant temperature of about 40°C.

Mobile phase: A mixture of water, methanol and 0.25 mol/L potassium dihydrogen phosphate TS (pH 3.5) (11:7:2).

Flow rate: Adjust so that the retention time of benzylpenicillin is about 18 minutes.

System suitability—

System performance: When the procedure is run with 20 μ L of the standard solution under the above operating conditions, *N,N'*-dibenzylethylenediamine and benzylpenicillin are eluted in this order with the resolution between these peaks being not less than 20.

System repeatability: When the test is repeated 6 times with 20 μ L of the standard solution under the above operating conditions, the relative standard deviations of the peak areas of *N,N'*-dibenzylethylenediamine and benzylpenicillin are not more than 2.0%, respectively.

(2) *N,N'*-Dibenzylethylenediamine—Determine the areas, A_T and A_S , of the peak corresponding to *N,N'*-dibenzylethylenediamine on the chromatograms obtained in (1) with the sample solution and standard solution.

Amount (%) of *N,N'*-dibenzylethylenediamine ($C_{16}H_{20}N_2$)
 $= M_S / M_T \times A_T / A_S \times 100 \times 0.667$

M_S : Amount (mg) of *N,N'*-dibenzylethylenediamine diacetate taken

M_T : Amount (mg) of Benzylpenicillin Benzathine Hydrate taken

0.667: Conversion factor for the molecular mass of *N,N'*-dibenzylethylenediamine diacetate ($C_{16}H_{20}N_2 \cdot 2CH_3COOH$) to that of *N,N'*-dibenzylethylenediamine (benzathine, $C_{16}H_{20}N_2$)

Containers and storage Containers—Tight containers.
Storage—Light-resistant.

Benzylpenicillin Potassium

Penicillin G Potassium

ベンジルペニシリンカリウム

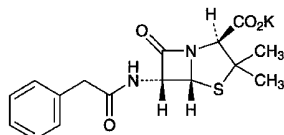

$C_{16}H_{17}KN_2O_4S$: 372.48
Monopotassium (2*S*,5*R*,6*R*)-3,3-dimethyl-7-oxo-6-[(phenylacetyl)amino]-4-thia-1-azabicyclo[3.2.0]heptane-2-carboxylate
[113-98-4]

Benzylpenicillin Potassium is the potassium salt of a penicillin substance having antibacterial activity produced by the growth of *Penicillium* species.

It contains not less than 1430 units and not more than 1630 units per mg, calculated on the dried basis. The potency of Benzylpenicillin Potassium is expressed as mass unit of benzylpenicillin potassium ($C_{16}H_{17}KN_2O_4S$). One unit of Benzylpenicillin Potassium is equivalent to 0.63 μ g of benzylpenicillin potassium.

Description Benzylpenicillin Potassium occurs as white, crystals or crystalline powder.

It is very soluble in water, and slightly soluble in ethanol (99.5).

Identification (1) Determine the absorption spectrum of a solution of Benzylpenicillin Potassium (1 in 1000) as directed under Ultraviolet-visible Spectrophotometry <2.24>, and compare the spectrum with the Reference Spectrum or the spectrum of a solution of Benzylpenicillin Potassium RS prepared in the same manner as the sample solution: both spectra exhibit similar intensities of absorption at the same wavelengths.

(2) Determine the infrared absorption spectrum of Benzylpenicillin Potassium as directed in the potassium bromide disk method under Infrared Spectrophotometry <2.25>, and compare the spectrum with the Reference Spectrum or the spectrum of Benzylpenicillin Potassium RS: both spectra exhibit similar intensities of absorption at the same wave numbers.

(3) Benzylpenicillin Potassium responds to Qualitative Tests <1.09> (1) for potassium salt.

Optical rotation <2.49> $[\alpha]_D^{20}$: +270 – +300° (1.0 g calculated on the dried basis, water, 50 mL, 100 mm).

pH <2.54> The pH of a solution obtained by dissolving 1.0 g of Benzylpenicillin Potassium in 100 mL of water is between 5.0 and 7.5.

Purity (1) Clarity and color of solution—A solution obtained by dissolving 1.0 g of Benzylpenicillin Potassium in

10 mL of water is clear, and its absorbance at 400 nm determined as directed under Ultraviolet-visible Spectrophotometry <2.24> is not more than 0.10.

(2) Heavy metals <1.07>—Proceed with 2.0 g of Benzylpenicillin Potassium according to Method 4, and perform the test. Prepare the control solution with 2.0 mL of Standard Lead Solution (not more than 10 ppm).

(3) Arsenic <1.11>—Prepare the test solution by incinerating 1.0 g of Benzylpenicillin Potassium according to Method 4, and perform the test. In the incineration, use a crucible of porcelain, and after addition of 10 mL of a solution of magnesium nitrate hexahydrate in ethanol (95) (1 in 10) add 1 mL of hydrogen peroxide (30), then burn the ethanol (not more than 2 ppm).

(4) Related substances—Dissolve 40 mg of Benzylpenicillin Potassium in 20 mL of water, and use this solution as the sample solution. Pipet 1 mL of the sample solution, add water to make exactly 100 mL, and use this solution as the standard solution. Perform the test with exactly 20 μ L each of the sample solution and standard solution as directed under Liquid Chromatography <2.01> according to the following conditions, and determine each peak area by the automatic integration method: the area of the peak other than benzylpenicillin obtained from the sample solution is not larger than the peak area of benzylpenicillin from the standard solution, and the total area of the peaks other than benzylpenicillin from the sample solution is not larger than 3 times the peak area of benzylpenicillin from the standard solution.

Operating conditions—

Detector, column, column temperature, mobile phase, and flow rate: Proceed as directed in the operating conditions in the Assay.

Time span of measurement: About 5 times as long as the retention time of benzylpenicillin, beginning after the solvent peak.

System suitability—

Test for required detectability: Pipet 10 mL of the standard solution, and add water to make exactly 100 mL. Confirm that the peak area of benzylpenicillin obtained with 20 μ L of this solution is equivalent to 7 to 13% of that with 20 μ L of the standard solution.

System performance: When the procedure is run with 20 μ L of the standard solution under the above operating conditions, the number of theoretical plates and the symmetry factor of the peak of benzylpenicillin are not less than 4000 and 0.7 to 1.2, respectively.

System repeatability: When the test is repeated 6 times with 20 μ L of the standard solution under the above operating conditions, the relative standard deviation of the peak area of benzylpenicillin is not more than 1.0%.

Loss on drying <2.41> Not more than 1.0% (3 g, reduced pressure not exceeding 0.67 kPa, 60°C, 3 hours).

Assay Weigh accurately amounts of Benzylpenicillin Potassium and Benzylpenicillin Potassium RS, equivalent to about 6×10^4 Units, dissolve each in water to make exactly 20 mL, and use these solutions as the sample solution and the standard solution, respectively. Perform the test with exactly 20 μ L each of the sample solution and standard solution as directed under Liquid Chromatography <2.01> according to the following conditions, and determine the peak areas, A_T and A_S , of benzylpenicillin in each solution.

$$\begin{aligned} &\text{Amount (unit) of benzylpenicillin potassium} \\ & (C_{16}H_{17}KN_2O_4S) \\ & = M_S \times A_T / A_S \end{aligned}$$

M_S : Amount (unit) of benzylpenicillin potassium RS taken

Operating conditions—

Detector: An ultraviolet absorption photometer (wavelength: 254 nm).

Column: A stainless steel column 4.6 mm in inside diameter and 25 cm in length, packed with octadecylsilanized silica gel for liquid chromatography (7 μ m in particle diameter).

Column temperature: A constant temperature of about 25°C.

Mobile phase: A mixture of diammonium hydrogen phosphate solution (33 in 5000) and acetonitrile (19:6), adjusted to pH 8.0 with phosphoric acid.

Flow rate: Adjust so that the retention time of benzylpenicillin is about 7.5 minutes.

System suitability—

System performance: When the procedure is run with 20 μ L of the standard solution under the above operating conditions, the number of theoretical plates and the symmetry factor of the peak of benzylpenicillin are not less than 2000 and not more than 3.0, respectively.

System repeatability: When the test is repeated 6 times with 20 μ L of the standard solution under the above operating conditions, the relative standard deviation of the peak area of benzylpenicillin is not more than 1.0%.

Containers and storage Containers—Tight containers.

Benzylpenicillin Potassium for Injection

Penicillin G Potassium for Injection

注射用ベンジルペニシリンカリウム

Benzylpenicillin Potassium for Injection is a preparation for injection which is dissolved before use.

It contains not less than 93.0% and not more than 107.0% of the labeled potency of benzylpenicillin potassium ($C_{16}H_{17}KN_2O_4S$: 372.48).

Method of preparation Prepare as directed under Injections, with Benzylpenicillin Potassium.

Description Benzylpenicillin Potassium for Injection occurs as white, crystals or crystalline powder.

Identification Proceed as directed in the Identification (2) under Benzylpenicillin Potassium.

Osmotic pressure ratio Being specified separately when the drug is granted approval based on the Law.

pH <2.54> The pH of a solution prepared by dissolving an amount of Benzylpenicillin Potassium for Injection, equivalent to 1.0×10^5 Units of Benzylpenicillin Potassium, in 10 mL of water is 5.0 to 7.5.

Purity Clarity and color of solution—A solution prepared by dissolving an amount of Benzylpenicillin Potassium for Injection, equivalent to 1.0×10^6 Units of Benzylpenicillin Potassium, in 10 mL of water is clear. Perform the test with this solution as directed under Ultraviolet-visible Spectrophotometry <2.24>: the absorbance at 400 nm is not more than 0.10.

Loss on drying <2.41> Not more than 1.2% (3 g, in vacuum, below 0.67 kPa, 60°C, 3 hours).

Bacterial endotoxins <4.01> Less than 1.25×10^{-4} EU/

Unit.

Uniformity of dosage units <6.02> It meets the requirement of the Mass variation test.

Foreign insoluble matter <6.06> Perform the test according to Method 2: it meets the requirement.

Insoluble particulate matter <6.07> It meets the requirement.

Sterility <4.06> Perform the test according to the Membrane filtration method: it meets the requirement.

Assay Weigh accurately the mass of the contents of not less than 10 containers of Benzylpenicillin Potassium for Injection. Weigh accurately an amount of a portion of the contents, equivalent to about 6×10^4 Units of Benzylpenicillin Potassium, dissolve in water to make exactly 20 mL, and use this solution as the sample solution. Separately, weigh accurately an amount of Benzylpenicillin Potassium RS, equivalent to about 6×10^4 Units, dissolve in water to make exactly 20 mL, and use this solution as the standard solution. Perform the test with exactly 5 μ L each of the sample solution and standard solution as directed under Liquid Chromatography <2.01> according to the following conditions. Determine the peak areas, A_T and A_S , of benzylpenicillin in each solution.

$$\begin{aligned} &\text{Amount (unit) of Benzylpenicillin Potassium} \\ & (C_{16}H_{17}KN_2O_4S) \\ & = M_S \times A_T / A_S \end{aligned}$$

M_S : Amount (unit) of Benzylpenicillin Potassium RS taken

Operating conditions—

Detector: An ultraviolet absorption photometer (wavelength: 254 nm).

Column: A stainless steel column 4.6 mm in inside diameter and 25 cm in length, packed with octadecylsilanized silica gel for liquid chromatography (7 μ m in particle diameter).

Column temperature: A constant temperature of about 25°C.

Mobile phase: To a mixture of diammonium hydrogen phosphate solution (33 in 5000) and acetonitril (19:6), add phosphoric acid to adjust the pH of this solution to 8.0.

Flow rate: Adjust so that the retention time of benzylpenicillin is about 7.5 minutes.

System suitability—

System performance: When the procedure is run with 5 μ L of the standard solution under the above operating conditions, the number of theoretical plates and the symmetry factor of the peak of benzylpenicillin are not less than 6000 and not more than 2.0, respectively.

System repeatability: When the test is repeated 6 times with 5 μ L of the standard solution under the above operating conditions, the relative standard deviation of the peak area of benzylpenicillin is not more than 1.0%.

Containers and storage Containers—Hermetic containers.

Bepotastine Besilate

ベポタスチンベシル酸塩

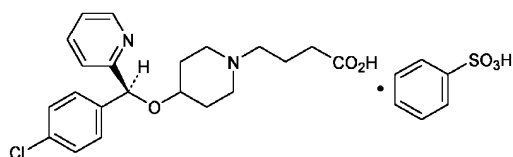

$C_{21}H_{25}ClN_2O_3 \cdot C_6H_6O_3S$: 547.06

(S)-4-[4-[(4-Chlorophenyl)(pyridin-2-yl)methoxy]piperidin-1-yl]butanoic acid monobenzenesulfonate

[190786-44-8]

Bepotastine Besilate contains not less than 99.0% and not more than 101.0% of bepotastine besilate ($C_{21}H_{25}ClN_2O_3 \cdot C_6H_6O_3S$), calculated on the anhydrous and residual solvent-free basis.

Description Bepotastine Besilate occurs as white to pale yellow-white, crystals or crystalline powder.

It is very soluble in acetic acid (100), and sparingly soluble in water and in ethanol (99.5).

The pH of a solution of 1 g of Bepotastine Besilate in 100 mL of water is about 3.8.

Identification (1) Determine the absorption spectrum of a solution of Bepotastine Besilate (1 in 20,000) as directed under Ultraviolet-visible Spectrophotometry <2.24>, and compare the spectrum with the Reference Spectrum: both spectra exhibit similar intensities of absorption at the same wavelengths.

(2) Determine the infrared absorption spectrum of Bepotastine Besilate as directed in the potassium bromide disk method under Infrared Spectrophotometry <2.25>, and compare the spectrum with the Reference Spectrum: both spectra exhibit similar intensities of absorption at the same wave numbers.

(3) Perform the test with Bepotastine Besilate as directed under Flame Coloration Test <1.04> (2): a green color appears.

(4) Mix well 30 mg of Bepotastine Besilate with 0.1 g of sodium nitrate and 0.1 g of anhydrous sodium carbonate, and gradually ignite. After cooling, dissolve the residue in 2 mL of dilute hydrochloric acid and 10 mL of water, filter if necessary, and add barium chloride TS: a white precipitate is produced.

Melting point <2.60> 159–163°C

Purity (1) Heavy metals <1.07>—Proceed with 2.0 g of Bepotastine Besilate according to Method 4, and perform the test. Prepare the control solution with 2.0 mL of Standard Lead Solution (not more than 10 ppm).

(2) Related substances—Dissolve 10 mg of Bepotastine Besilate in 25 mL of the mobile phase, and use this solution as the sample solution. Pipet 1 mL of the sample solution, add the mobile phase to make exactly 100 mL, and use this solution as the standard solution. Perform the test with exactly 20 μ L each of the sample solution and standard solution as directed under Liquid Chromatography <2.01> according to the following conditions, and determine each peak area by the automatic integration method: the area of the peak, having a relative retention time of about 2.5 to bepotastine, obtained from the sample solution is not larger than the peak area of bepotastine from the standard solution, and the area of the peak other than bepotastine and the

peak mentioned above from the sample solution is not larger than 1/10 times the peak area of bepotastine from the standard solution. Furthermore, the total area of the peaks other than bepotastine from the sample solution is not larger than the peak area of bepotastine from the standard solution.

Operating conditions—

Detector: An ultraviolet absorption photometer (wavelength: 220 nm).

Column: A stainless steel column 4.6 mm in inside diameter and 15 cm in length, packed with octylsilylated silica gel for liquid chromatography (5 μ m in particle diameter).

Column temperature: A constant temperature of about 40°C.

Mobile phase: Dissolve 1.0 g of sodium 1-pentane sulfonate in a mixture of 0.05 mol/L potassium dihydrogen phosphate TS (pH 3.0) and acetonitrile (7:3) to make 1000 mL.

Flow rate: Adjust so that the retention time of bepotastine is about 6 minutes.

Time span of measurement: About 5 times as long as the retention time of bepotastine, beginning after the peak of benzenesulfonic acid.

System suitability—

Test for required detectability: Pipet 2.5 mL of the standard solution, and add the mobile phase to make exactly 50 mL. Confirm that the peak area of bepotastine obtained with 20 μ L of this solution is equivalent to 3.5 to 6.5% of that with 20 μ L of the standard solution.

System performance: When the procedure is run with 20 μ L of the standard solution under the above operating conditions, the number of theoretical plates and the symmetry factor of the peak of bepotastine are not less than 3000 and 0.8 to 1.5, respectively.

System repeatability: When the test is repeated 6 times with 20 μ L of the standard solution under the above operating conditions, the relative standard deviation of the peak area of bepotastine is not more than 2.0%.

(3) **Enantiomer—**Dissolve 5.0 mg of Bepotastine Besilate in 25 mL of the mobile phase, and use this solution as the sample solution. Pipet 1 mL of the sample solution, add the mobile phase to make exactly 200 mL, and use this solution as the standard solution. Perform the test with exactly 10 μ L each of the sample solution and standard solution as directed under Liquid Chromatography <2.01> according to the following conditions, and determine the area of each peak by the automatic integration method: the peak area of the enantiomer having the relative retention time of about 0.9 to bepotastine obtained from the sample solution is not larger than the peak area of bepotastine from the standard solution.

Operating conditions—

Detector: An ultraviolet absorption photometer (wavelength: 225 nm).

Column: A stainless steel column 6.0 mm in inside diameter and 15 cm in length, packed with β -cyclodextrin binding silica gel for liquid chromatography (5 μ m in particle diameter).

Column temperature: A constant temperature of about 40°C.

Mobile phase: A mixture of 0.02 mol/L potassium dihydrogen phosphate TS and acetonitrile (3:1).

Flow rate: Adjust so that the retention time of bepotastine is about 17 minutes.

System suitability—

System performance: When the procedure is run with 10 μ L of the standard solution under the above operating con-

ditions, the number of theoretical plates and the symmetry factor of the peak of bepotastine are not less than 3000 and 0.8 to 1.5, respectively.

System repeatability: When the test is repeated 6 times with 10 μL of the standard solution under the above operating conditions, the relative standard deviation of the peak area of bepotastine is not more than 5.0%.

Water <2.48> Not more than 0.1% (0.3 g, coulometric titration).

Residue on ignition <2.44> Not more than 0.1% (1 g).

Assay Weigh accurately about 0.8 g of Bepotastine Besilate, dissolve in 60 mL of acetic acid (100), and titrate <2.50> with 0.1 mol/L perchloric acid VS (potentiometric titration). Perform a blank determination in the same manner, and make any necessary correction.

Each mL of 0.1 mol/L perchloric acid VS
= 54.71 mg of $\text{C}_{21}\text{H}_{25}\text{ClN}_2\text{O}_3 \cdot \text{C}_6\text{H}_6\text{O}_3\text{S}$

Containers and storage Containers—Tight containers.

Bepotastine Besilate Tablets

ベポタスチンベシル酸塩錠

Bepotastine Besilate Tablets contain not less than 95.0% and not more than 105.0% of the labeled amount of bepotastine besilate ($\text{C}_{21}\text{H}_{25}\text{ClN}_2\text{O}_3 \cdot \text{C}_6\text{H}_6\text{O}_3\text{S}$; 547.06).

Method of preparation Prepare as directed under Tablets, with Bepotastine Besilate.

Identification To an amount of powdered Bepotastine Besilate Tablets, equivalent to 2 mg of Bepotastine Besilate, add 40 mL of water, shake thoroughly, and filter. Determine the absorption spectrum of the filtrate as directed under Ultraviolet-visible Spectrophotometry <2.24>: it exhibits a maximum between 260 nm and 264 nm.

Uniformity of dosage units <6.02> Perform the test according to the following method: it meets the requirement of the Content uniformity test.

To 1 tablet of Bepotastine Besilate Tablets add exactly $V/5$ mL of the internal standard solution, then add the mobile phase to make V mL so that each mL contains about 0.4 mg of bepotastine besilate ($\text{C}_{21}\text{H}_{25}\text{ClN}_2\text{O}_3 \cdot \text{C}_6\text{H}_6\text{O}_3\text{S}$), shake vigorously for 10 minutes, and filter through a membrane filter with a pore size not exceeding 0.45 μm . Discard the first 5 mL of the filtrate, to 2 mL of the subsequent filtrate add the mobile phase to make 10 mL, and use this solution as the sample solution. Then, proceed as directed in the Assay.

Amount (mg) of bepotastine besilate
($\text{C}_{21}\text{H}_{25}\text{ClN}_2\text{O}_3 \cdot \text{C}_6\text{H}_6\text{O}_3\text{S}$)
= $M_S \times Q_T/Q_S \times V/50$

M_S : Amount (mg) of bepotastine besilate for assay taken, calculated on the anhydrous and residual solvent-free basis

Internal standard solution—A solution of ethyl parahydroxybenzoate in acetonitrile (1 in 4500).

Dissolution <6.10> When the test is performed at 50 revolutions per minute according to the Paddle method, using 900 mL of water as the dissolution medium, the dissolution rate

in 30 minutes of Bepotastine Besilate Tablets is not less than 85%.

Start the test with 1 tablet of Bepotastine Besilate Tablets, withdraw not less than 20 mL of the medium at the specified minute after starting the test, and filter through a membrane filter with a pore size not exceeding 0.45 μm . Discard not less than 10 mL of the first filtrate, pipet V mL of the subsequent filtrate, add the mobile phase to make exactly V' mL so that each mL contains about 2.2 μg of bepotastine besilate ($\text{C}_{21}\text{H}_{25}\text{ClN}_2\text{O}_3 \cdot \text{C}_6\text{H}_6\text{O}_3\text{S}$), and use this solution as the sample solution. Separately, weigh accurately about 0.11 g of bepotastine besilate for assay (separately determine the water <2.48> and the residual solvent in the same manner as Bepotastine Besilate), and dissolve in water to make exactly 100 mL. Pipet 1 mL of this solution, add water to make exactly 100 mL. Pipet 2 mL of this solution, add the mobile phase to make exactly 10 mL, and use this solution as the standard solution. Perform the test with exactly 50 μL each of the sample solution and standard solution as directed under Liquid Chromatography <2.01> according to the following conditions, and determine the peak areas, A_T and A_S , of bepotastine in each solution.

Dissolution rate (%) with respect to the labeled amount of bepotastine besilate ($\text{C}_{21}\text{H}_{25}\text{ClN}_2\text{O}_3 \cdot \text{C}_6\text{H}_6\text{O}_3\text{S}$)
= $M_S \times A_T/A_S \times V'/V \times 1/C \times 9/5$

M_S : Amount (mg) of bepotastine besilate for assay taken, calculated on the anhydrous and residual solvent-free basis

C : Labeled amount (mg) of bepotastine besilate ($\text{C}_{21}\text{H}_{25}\text{ClN}_2\text{O}_3 \cdot \text{C}_6\text{H}_6\text{O}_3\text{S}$) in 1 tablet

Operating conditions—

Proceed as directed in the operating conditions in the Assay.

System suitability—

System performance: When the procedure is run with 50 μL of the standard solution under the above operating conditions, the number of theoretical plates and the symmetry factor of the peak of bepotastine are not less than 5000 and not more than 1.5, respectively.

System repeatability: When the test is repeated 6 times with 50 μL of the standard solution under the above operating conditions, the relative standard deviation of the peak area of bepotastine is not more than 1.5%.

Assay Weigh accurately the mass of not less than 20 tablets of Bepotastine Besilate Tablets, and powder. Weigh accurately a portion of the powder, equivalent to about 10 mg of bepotastine besilate ($\text{C}_{21}\text{H}_{25}\text{ClN}_2\text{O}_3 \cdot \text{C}_6\text{H}_6\text{O}_3\text{S}$), add exactly 5 mL of the internal standard solution, then add 20 mL of the mobile phase, shake thoroughly for 10 minutes, and filter through a membrane filter with a pore size not exceeding 0.45 μm . Discard the first 5 mL of the filtrate, to 2 mL of the subsequent filtrate add the mobile phase to make 10 mL, and use this solution as the sample solution. Separately, weigh accurately about 20 mg of bepotastine besilate for assay (separately determine the water <2.48> and the residual solvent in the same manner as Bepotastine Besilate), add exactly 10 mL of the internal standard solution, and dissolve in the mobile phase to make 50 mL. To 2 mL of this solution add the mobile phase to make 10 mL, and use this solution as the standard solution. Perform the test with 20 μL each of the sample solution and standard solution as directed under Liquid Chromatography <2.01> according to the following conditions, and calculate the ratios, Q_T and Q_S , of the peak area of bepotastine to that of the internal standard.

$$\begin{aligned} & \text{Amount (mg) of bepotastine besilate} \\ & (\text{C}_{21}\text{H}_{25}\text{ClN}_2\text{O}_3 \cdot \text{C}_6\text{H}_6\text{O}_3\text{S}) \\ & = M_S \times Q_T/Q_S \times 1/2 \end{aligned}$$

M_S : Amount (mg) of bepotastine besilate for assay taken, calculated on the anhydrous and residual solvent-free basis

Internal standard solution—A solution of ethyl parahydroxybenzoate in acetonitrile (1 in 4500).

Operating conditions—

Detector: An ultraviolet absorption photometer (wavelength: 260 nm).

Column: A stainless steel column 4.6 mm in inside diameter and 15 cm in length, packed with octylsilylated silica gel for liquid chromatography (5 μm in particle diameter).

Column temperature: A constant temperature of about 40°C.

Mobile phase: A solution of sodium 1-pentanesulfonate in a mixture of 0.05 mol/L potassium dihydrogen phosphate TS (pH 3.0) and acetonitrile (7:3) (1 in 1000).

Flow rate: Adjust so that the retention time of bepotastine is about 6 minutes.

System suitability—

System performance: When the procedure is run with 20 μL of the standard solution under the above operating conditions, bepotastine and the internal standard are eluted in this order with the resolution between these peaks being not less than 5.

System repeatability: When the test is repeated 6 times with 20 μL of the standard solution under the above operating conditions, the relative standard deviation of the ratio of the peak area of bepotastine to that of the internal standard is not more than 1.0%.

Containers and storage Containers—Tight containers.

Beraprost Sodium

ベラプロストナトリウム

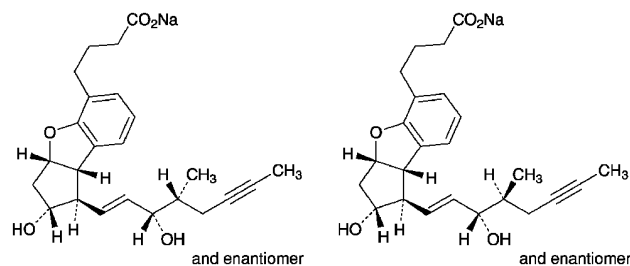

$\text{C}_{24}\text{H}_{29}\text{NaO}_5$: 420.47

Monosodium (1*R*,2*R*,3*aSR*,8*bSR*)-2,3,3*a*,8*b*-tetrahydro-2-hydroxy-1-[(1*E*,3*SR*,4*RS*)-3-hydroxy-4-methyloct-1-en-6-yn-1-yl]-1*H*-cyclopenta[*b*]benzofuran-5-butanoate

Monosodium (1*S*,2*S*,3*aSR*,8*bSR*)-2,3,3*a*,8*b*-tetrahydro-2-hydroxy-1-[(1*E*,3*SR*,4*RS*)-3-hydroxy-4-methyloct-1-en-6-yn-1-yl]-1*H*-cyclopenta[*b*]benzofuran-5-butanoate

[88475-69-8]

Beraprost Sodium, when dried, contains not less than 98.5% and not more than 101.0% of beraprost sodium ($\text{C}_{24}\text{H}_{29}\text{NaO}_5$).

Description Beraprost Sodium occurs as a white powder.

It is very soluble in methanol, and freely soluble in water and in ethanol (99.5).

It is hygroscopic.

A solution of Beraprost Sodium (1 in 200) shows no optical rotation.

Identification (1) Determine the absorption spectrum of a solution of Beraprost Sodium in methanol (3 in 50,000) as directed under Ultraviolet-visible Spectrophotometry <2.24>, and compare the spectrum with the Reference Spectrum: both spectra exhibit similar intensities of absorption at the same wavelengths.

(2) Determine the infrared absorption spectrum of previously dried Beraprost Sodium as directed in the potassium bromide disk method under Infrared Spectrophotometry <2.25>, and compare the spectrum with the Reference Spectrum: both spectra exhibit similar intensities of absorption at the same wave numbers.

(3) A solution of Beraprost Sodium in methanol (1 in 1000) responds to Qualitative Tests <1.09> (1) for sodium salt.

Purity Related substances—Dissolve 20 mg of Beraprost Sodium in 2 mL of methanol, and use this solution as the sample solution. Perform the test with 15 μL of the sample solution as directed under Liquid Chromatography <2.01> according to the following conditions. Determine each peak area by the automatic integration method, and calculate their amounts by the area percentage method: the amount of the peak having the relative retention time of about 0.5 to the second eluting principal peak of beraprost and the two adjacent peaks at the relative retention time of about 1.7 and another two adjacent peaks at the relative retention time of about 2.0 are not more than 0.2%, respectively, the amount of the peak at the relative retention time of about 1.2 is not more than 0.3%, the amount of the peak, other than the two peaks of beraprost and the peaks mentioned above, is less than 0.1%, and the total amount of the peaks, other than the two peaks of beraprost, is not more than 1.5%.

Operating conditions—

Detector: An ultraviolet absorption photometer (wavelength: 285 nm).

Column: A stainless steel column 4 mm in inside diameter and 25 cm in length, packed with octadecylsilylated silica gel for liquid chromatography (4 μm in particle diameter).

Column temperature: A constant temperature of about 35°C.

Mobile phase A: A mixture of water, acetonitrile, methanol and acetic acid (100) (640:330:30:1).

Mobile phase B: A mixture of acetonitrile, water and acetic acid (100) (900:100:1).

Flowing of mobile phase: Control the gradient by mixing the mobile phases A and B as directed in the following table.

Time after injection of sample (min)	Mobile phase A (vol%)	Mobile phase B (vol%)
0 – 30	100	0
30 – 45	100 → 56	0 → 44
45 – 60	56	44
60 – 70	56 → 0	44 → 100
70 – 80	0	100

Flow rate: Adjust so that the retention time of the second peak of beraprost is about 23 minutes.

Time span of measurement: For 80 minutes after injection, beginning after the solvent peak.

System suitability—

Test for required detectability: To 1 mL of the sample solution add methanol to make 20 mL. To 1 mL of this solu-

tion add methanol to make 20 mL, and use this solution as the solution for system suitability test. Pipet 2 mL of the solution for system suitability test, and add methanol to make exactly 10 mL. Confirm that the total area of the two peaks of beraprost obtained with 15 μ L of this solution is equivalent to 14 to 26% of that with 15 μ L of the solution for system suitability test.

System performance: When the procedure is run with 15 μ L of the solution for system suitability test under the above operating conditions, the resolution between the two peaks of beraprost is not less than 1.5.

System repeatability: When the test is repeated 6 times with 15 μ L of the solution for system suitability test under the above operating conditions, the relative standard deviation of the total area of the two peaks of beraprost is not more than 2.0%.

Loss on drying <2.41> Not more than 3.0% (0.5 g, reduced pressure not exceeding 0.67 kPa, silica gel, 60°C, 5 hours).

Isomer ratio Dissolve 10 mg of Beraprost Sodium in 5 mL of methanol, and use this solution as the sample solution. Perform the test with 15 μ L of the sample solution as directed under Liquid Chromatography <2.01> according to the following conditions, and determine the areas, A_a of the peak which appears at the retention time about 25 minutes, and A_b of the peak which appears at about 27 minutes: A_b/A_a is between 0.90 and 1.10.

Operating conditions—

Detector: An ultraviolet absorption photometer (wavelength: 285 nm).

Column: A stainless steel column 6 mm in inside diameter and 15 cm in length, packed with octadecylsilanized silica gel for liquid chromatography (5 μ m in particle diameter).

Column temperature: A constant temperature of about 40°C.

Mobile phase: A mixture of methanol, water and acetic acid (100) (600:400:1).

Flow rate: Adjust so that the retention time of the second eluting peak of beraprost is about 27 minutes.

System suitability—

System performance: When the procedure is run with 15 μ L of the sample solution under the above operating conditions, the resolution between the two peaks of beraprost is not less than 1.2.

System repeatability: When the test is repeated 6 times with 15 μ L of the sample solution under the above operating conditions, the relative standard deviation of the total area of the two peak of beraprost is not more than 2.0%.

Assay Weigh accurately about 0.1 g of Beraprost Sodium, previously dried, dissolve in 30 mL of diluted ethanol with freshly boiled and cooled water (7 in 10), add exactly 2 mL of 0.2 mol/L hydrochloric acid TS, and titrate <2.50> with 0.025 mol/L sodium hydroxide-ethanol VS from the first equivalence point to the second equivalence point (potentiometric titration).

Each mL of 0.025 mol/L sodium hydroxide-ethanol VS = 10.51 mg of $C_{24}H_{29}NaO_5$

Containers and storage Containers—Tight containers.

Storage—Light-resistant.

Beraprost Sodium Tablets

ベラプロストナトリウム錠

Beraprost Sodium Tablets contain not less than 95.0% and not more than 105.0% of the labeled amount of beraprost sodium ($C_{24}H_{29}NaO_5$; 420.47).

Method of preparation Prepare as directed under Tablets, with Beraprost Sodium.

Identification Powder Beraprost Sodium Tablets. To a portion of the powder, equivalent to 0.2 mg of Beraprost Sodium, add 10 mL of water, shake, and filter through a membrane filter with a pore size not exceeding 0.45 μ m. To the filtrate add 1 mL of 0.1 mol/L hydrochloric acid TS, extract with two 50-mL portions of ethyl acetate, combine the extracts, and evaporate in reduced pressure at 40°C. Dissolve the residue in 1 mL of methanol, use this solution as the sample solution. Separately, dissolve 1 mg of beraprost sodium in 5 mL of methanol, and use this solution as the standard solution. Perform the test with these solutions as directed under Thin-layer Chromatography <2.03>. Spot 10 μ L each of the sample solution and standard solution on a plate of silica gel for thin-layer chromatography, develop the plate with the upper layer of a mixture of 11 volumes of ethyl acetate, 10 volumes of water, 4 volumes of isooctane and 2 volumes of acetic acid (100) to a distance of about 10 cm, air-dry the plate, and heat at 120°C for 30 minutes. After cooling, spray evenly a mixture of ethanol (99.5), water, sulfuric acid and 4-methoxybenzaldehyde (17:2:1:1) on the plate, and heat the plate at 120°C for 3 minutes: the principal spot obtained from the sample solution and the spot from the standard solution show the same R_f value.

Uniformity of dosage units <6.02> Perform the test according to the following method: it meets the requirement of the Content uniformity test.

To 1 tablet of Beraprost Sodium Tablets add exactly V mL of the internal standard solution so that each mL contains about 2 μ g of beraprost sodium ($C_{24}H_{29}NaO_5$), shake at 30°C for 30 minutes, filter through a membrane filter with a pore size not exceeding 0.45 μ m, and use the filtrate as the sample solution. Then, proceed as directed in the Assay.

$$\begin{aligned} \text{Amount (mg) of beraprost sodium (C}_{24}\text{H}_{29}\text{NaO}_5) \\ = M_S \times Q_T/Q_S \times V/10,000 \end{aligned}$$

M_S : Amount (mg) of beraprost sodium for assay taken

Internal standard solution—A mixture of water and a solution of 4-isopropylphenol in methanol (1 in 250,000) (1:1).

Dissolution <6.10> When the test is performed at 50 revolutions per minute according to the Paddle method, using 900 mL of water as the dissolution medium, the dissolution rate in 30 minutes of Beraprost Sodium Tablets is not less than 85%.

Start the test with 1 tablet of Beraprost Sodium Tablets, withdraw not less than 20 mL of the medium at the specified minute after starting the test, and filter through a membrane filter with a pore size not exceeding 0.45 μ m. Discard not less than 10 mL of the first filtrate, pipet V' mL of the subsequent filtrate, add water to make exactly V' mL so that each mL contains about 22 ng of beraprost sodium ($C_{24}H_{29}NaO_5$), and use this solution as the sample solution. Separately, weigh accurately about 20 mg of beraprost sodium for assay, previously dried in reduced pressure not exceeding 0.67 kPa at 60°C for 5 hours using silica gel as a desiccant, and dis-

solve in methanol to make exactly 100 mL. Pipet 2 mL of this solution, and add water to make exactly 200 mL. Pipet 2 mL of this solution, add water to make exactly 200 mL, and use this solution as the standard solution. Perform the test with exactly 200 μ L each of the sample solution and standard solution as directed under Liquid Chromatography <2.01> according to the following conditions, and determine the total areas, A_T and A_S , of the two peaks of beraprost in each solution.

Dissolution rate (%) with respect to the labeled amount of beraprost sodium ($C_{24}H_{29}NaO_5$)
 $= M_S \times A_T/A_S \times V'/V \times 1/C \times 9/100$

M_S : Amount (mg) of beraprost sodium for assay taken
 C: Labeled amount (mg) of beraprost sodium ($C_{24}H_{29}NaO_5$) in 1 tablet

Operating conditions—

Detector, column temperature, and mobile phase: Proceed as directed in the operating conditions in the Assay.

Column: A stainless steel column 4.6 mm in inside diameter and 15 cm in length, packed with octadecylsilanized silica gel for liquid chromatography (5 μ m in particle diameter).

Flow rate: Adjust so that the retention time of the first eluting peak of beraprost is about 10 minutes.

System suitability—

System performance: When the procedure is run with 200 μ L of the standard solution under the above operating conditions, the resolution between the two peaks of beraprost is not less than 1.2.

System repeatability: When the test is repeated 6 times with 200 μ L of the standard solution under the above operating conditions, the relative standard deviation of the total area of the two peaks of beraprost is not more than 2.0%.

Assay Weigh accurately the mass of not less than 20 Beraprost Sodium Tablets, and powder. Weigh accurately a portion of the powder, equivalent to about 40 μ g of beraprost sodium ($C_{24}H_{29}NaO_5$), add exactly 20 mL of the internal standard solution, shake at 30°C for 30 minutes, filter through a membrane filter with a pore size not exceeding 0.45 μ m, and use the filtrate as the sample solution. Separately, weigh accurately about 20 mg of beraprost sodium for assay, previously dried in reduced pressure not exceeding 0.67 kPa at 60°C for 5 hours using silica gel as a desiccant, and dissolve in methanol to make exactly 100 mL. Pipet 10 mL of this solution, and add methanol to make exactly 200 mL. Pipet 4 mL of this solution, and evaporate under reduced pressure at 40°C. To the residue add exactly 20 mL of the internal standard solution, and use this solution as the standard solution. Perform the test with 20 μ L each of the sample solution and standard solution as directed under Liquid Chromatography <2.01> according to the following conditions, and calculate the ratios, Q_T and Q_S , of the total area of the two peaks of beraprost to the peak area of the internal standard.

Amount (mg) of beraprost sodium ($C_{24}H_{29}NaO_5$)
 $= M_S \times Q_T/Q_S \times 1/500$

M_S : Amount (mg) of beraprost sodium for assay taken

Internal standard solution—A mixture of water and a solution of 4-isopropylphenol in methanol (1 in 250,000) (1:1).

Operating conditions—

Detector: A fluorophotometer (excitation wavelength: 285 nm, fluorescence wavelength: 614 nm).

Column: A stainless steel column 6 mm in inside diameter and 15 cm in length, packed with octadecylsilanized silica gel

for liquid chromatography (5 μ m in particle diameter).

Column temperature: A constant temperature of about 40°C.

Mobile phase: A mixture of methanol, water and acetic acid (100) (650:350:1).

Flow rate: Adjust so that the retention time of the first eluting peak of beraprost is about 15 minutes.

System suitability—

System performance: When the procedure is run with 20 μ L of the standard solution under the above operating conditions, the internal standard and beraprost are eluted in this order and the resolution between the internal standard peak and the first eluting peak of beraprost is not less than 11, and the resolution between the two peaks of beraprost is not less than 1.5.

System repeatability: When the test is repeated 6 times with 20 μ L of the standard solution under the above operating conditions, the relative standard deviation of the ratio of the total area of the two peaks of beraprost to the peak area of the internal standard is not more than 2.0%.

Containers and storage Containers—Well-closed containers.

Berberine Chloride Hydrate

ベルベリン塩化物水和物

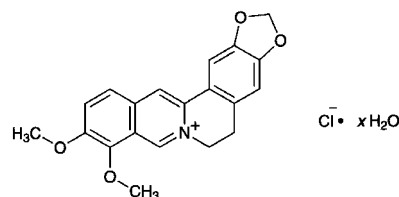

$C_{20}H_{18}ClNO_4 \cdot xH_2O$
 9,10-Dimethoxy-5,6-dihydro[1,3]dioxolo[4,5-g]isoquino[3,2-a]isoquinolin-7-ium chloride hydrate
 [633-65-8, anhydride]

Berberine Chloride Hydrate contains not less than 95.0% and not more than 102.0% of berberine chloride ($C_{20}H_{18}ClNO_4$: 371.81), calculated on the anhydrous basis.

Description Berberine Chloride Hydrate occurs as yellow, crystals or crystalline powder. It is odorless or has a faint, characteristic odor. It has a very bitter taste.

It is sparingly soluble in methanol, slightly soluble in ethanol (95), and very slightly soluble in water.

Identification (1) Determine the absorption spectrum of a solution of Berberine Chloride Hydrate (1 in 100,000) as directed under Ultraviolet-visible Spectrophotometry <2.24>, and compare the spectrum with the Reference Spectrum or the spectrum of a solution of Berberine Chloride RS prepared in the same manner as the sample solution: both spectra exhibit similar intensities of absorption at the same wavelengths.

(2) Determine the infrared absorption spectrum of Berberine Chloride Hydrate as directed in the potassium bromide disk method under Infrared Spectrophotometry <2.25>, and compare the spectrum with the Reference Spectrum or the spectrum of Berberine Chloride RS: both spectra exhibit similar intensities of absorption at the same wave numbers.

(3) Dissolve 0.1 g of Berberine Chloride Hydrate in 20

mL of water by warming, add 0.5 mL of nitric acid, cool, and filter after allowing to stand for 10 minutes. To 3 mL of the filtrate add 1 mL of silver nitrate TS, and collect the produced precipitate: the precipitate does not dissolve in dilute nitric acid, but it dissolves in an excess amount of ammonia TS.

Purity (1) Acidity—Shake thoroughly 0.10 g of Berberine Chloride Hydrate with 30 mL of water, and filter. To the filtrate add 2 drops of phenolphthalein TS and 0.10 mL of 0.1 mol/L sodium hydroxide VS: the yellow color changes to an orange to red color.

(2) Sulfate <1.14>—Shake 1.0 g of Berberine Chloride Hydrate with 48 mL of water and 2 mL of dilute hydrochloric acid for 1 minute, and filter. Discard the first 5 mL of the filtrate, take the subsequent 25 mL of the filtrate, add water to make 50 mL, and perform the test using this solution as the test solution. Prepare the control solution with 0.50 mL of 0.005 mol/L sulfuric acid VS, 1 mL of dilute hydrochloric acid, 5 to 10 drops of bromophenol blue TS and water to make 50 mL (not more than 0.048%).

(3) Heavy metals <1.07>—Proceed with 1.0 g of Berberine Chloride Hydrate according to Method 2, and perform the test. Prepare the control solution with 3.0 mL of Standard Lead Solution (not more than 30 ppm).

(4) Related substances—Dissolve 10 mg of Berberine Chloride Hydrate in 100 mL of the mobile phase, and use this solution as the sample solution. Pipet 4 mL of the sample solution, add the mobile phase to make exactly 100 mL, and use this solution as the standard solution. Perform the test with exactly 10 μ L each of the sample solution and standard solution as directed under Liquid Chromatography <2.01> according to the following conditions. Determine each peak area of both solutions by the automatic integration method: the total area of the peaks other than berberine obtained from the sample solution is not larger than the peak area of berberine from the standard solution.

Operating conditions—

Detector, column, column temperature, mobile phase, flow rate, and selection of column: Proceed as directed in the operating conditions in the Assay.

Time span of measurement: About 2 times as long as the retention time of berberine, beginning after the solvent peak.

Detection sensitivity: Adjust so that the peak height of berberine obtained from 10 μ L of the standard solution is about 10% of the full scale.

Water <2.48> 8 – 12% (0.1 g, volumetric titration, direct titration).

Residue on ignition <2.44> Not more than 0.1% (1 g).

Assay Weigh accurately about 10 mg of Berberine Chloride Hydrate, dissolve in the mobile phase to make exactly 100 mL, and use this solution as the sample solution. Separately, weigh accurately about 10 mg of Berberine Chloride RS (separately, determine the water content <2.48> in the same manner as Berberine Chloride Hydrate), and dissolve in the mobile phase to make exactly 100 mL, and use this solution as the standard solution. Perform the test with exactly 10 μ L each of the sample solution and standard solution as directed under Liquid Chromatography <2.01> according to the following conditions. Determine the peak areas, A_T and A_S of berberine in each solution.

$$\begin{aligned} &\text{Amount (mg) of berberine chloride (C}_{20}\text{H}_{18}\text{ClNO}_4) \\ &= M_S \times A_T / A_S \end{aligned}$$

M_S : Amount (mg) of Berberine Chloride RS taken, calculated on the anhydrous basis

Operating conditions—

Detector: An ultraviolet absorption photometer (wavelength: 345 nm).

Column: A stainless steel column about 4 mm in inside diameter and about 25 cm in length, packed with octadecylsilylated silica gel for liquid chromatography (5 μ m in particle diameter).

Column temperature: A constant temperature of about 40°C.

Mobile phase: Dissolve 3.4 g of monobasic potassium phosphate and 1.7 g of sodium lauryl sulfate in 1000 mL of a mixture of water and acetonitrile (1:1).

Flow rate: Adjust so that the retention time of berberine is about 10 minutes.

Selection of column: Dissolve each 1 mg of berberine chloride and palmatin chloride in the mobile phase to make 10 mL. Proceed with 10 μ L of this solution under the above operating conditions, and calculate the resolution. Use a column giving elution of palmatin and berberine in this order with the resolution between these peaks being not less than 1.5.

System repeatability: When the test is repeated 5 times with the standard solution under the above operating conditions, the relative standard deviation of the peak areas of berberine is not more than 1.5%.

Containers and storage Containers—Tight containers.

Storage—Light-resistant.

Berberine Tannate

タンニン酸ベルベリン

Berberine Tannate is a compound of berberine and tannic acid.

It contains not less than 27.0% and not more than 33.0% of berberine (C₂₀H₁₉NO₅: 353.37), calculated on the anhydrous basis.

Description Berberine Tannate occurs as a yellow to light yellow-brown powder. It is odorless or has a faint, characteristic odor, and is tasteless.

It is practically insoluble in water, in acetonitrile, in methanol and in ethanol (95).

Identification (1) To 0.1 g of Berberine Tannate add 10 mL of ethanol (95), and heat in a water bath for 3 minutes with shaking. Cool, filter, and to 5 mL of the filtrate add 1 drop of iron (III) chloride TS: a blue-green color is produced, and on allowing to stand, a bluish black precipitate is formed.

(2) Dissolve 0.01 g of Berberine Tannate in 10 mL of methanol and 0.4 mL of 1 mol/L hydrochloric acid TS, and add water to make 200 mL. To 8 mL of the solution add water to make 25 mL. Determine the absorption spectrum of the solution as directed under Ultraviolet-visible Spectrophotometry <2.24>, and compare the spectrum with the Reference Spectrum: both spectra exhibit similar intensities of absorption at the same wavelengths.

(3) Determine the infrared absorption spectrum of Berberine Tannate as directed in the potassium bromide disk method under Infrared Spectrophotometry <2.25>, and compare the spectrum with the Reference Spectrum: both spectra exhibit similar intensities of absorption at the same wave numbers.

Purity (1) Acidity—To 0.10 g of Berberine Tannate add

30 mL of water, and filter after shaking well. To the filtrate add 2 drops of phenolphthalein TS and 0.10 mL of 0.1 mol/L sodium hydroxide VS: the color of the solution changes from yellow to orange to red.

(2) Chloride <1.03>—Shake 1.0 g of Berberine Tannate with 38 mL of water and 12 mL of dilute nitric acid for 5 minutes, and filter. Discard the first 5 mL of the filtrate, to 25 mL of the subsequent filtrate add water to make 50 mL, and perform the test using this solution as the test solution. Prepare the control solution with 0.50 mL of 0.01 mol/L hydrochloric acid VS by adding 6 mL of dilute nitric acid, 10 to 15 drops of bromophenol blue TS and water to make 50 mL (not more than 0.035%).

(3) Sulfate <1.14>—Shake 1.0 g of Berberine Tannate with 48 mL of water and 2 mL of dilute hydrochloric acid for 1 minute, and filter. Discard the first 5 mL of the filtrate, take the subsequent 25 mL of the filtrate, add water to make 50 mL, and perform the test using this solution as the test solution. Prepare the control solution with 0.50 mL of 0.005 mol/L sulfuric acid VS, 1 mL of dilute hydrochloric acid, 5 to 10 drops of bromophenol blue TS and water to make 50 mL (not more than 0.048%).

(4) Heavy metals <1.07>—Proceed with 1.0 g of Berberine Tannate according to Method 2, and perform the test. Prepare the control solution with 3.0 mL of Standard Lead Solution (not more than 30 ppm).

(5) Related substances—Dissolve 10 mg of Berberine Tannate in 100 mL of the mobile phase, and use this solution as the sample solution. Pipet 4 mL of the sample solution, add the mobile phase to make exactly 100 mL, and use this solution as the standard solution. Perform the test with exactly 10 μ L each of the sample solution and standard solution as directed under Liquid Chromatography <2.01> according to the following conditions. Determine each peak area of both solutions by the automatic integration method: the total area of the peaks other than berberine obtained from the sample solution is not larger than the peak area of berberine from the standard solution.

Operating conditions—

Detector, column, column temperature, mobile phase, and flow rate: Proceed as directed in the operating conditions in the Assay.

Time span of measurement: About 2 times as long as the retention time of berberine, beginning after the solvent peak.

System suitability—

System performance: Proceed as directed in the system suitability in the Assay.

Test for required detectability: To exactly 2 mL of the standard solution add the mobile phase to make exactly 20 mL. Confirm that the peak area of berberine obtained with 10 μ L of this solution is equivalent to 7 to 13% of that with 10 μ L of the standard solution.

System repeatability: When the test is repeated 6 times with 10 μ L of the standard solution under the above operating conditions, the relative standard deviation of the peak area of berberine is not more than 3.0%.

Water <2.48> Not more than 6.0% (0.7 g, volumetric titration, direct titration).

Residue on ignition <2.44> Not more than 1.0% (1 g).

Assay Weigh accurately about 30 mg of Berberine Tannate, dissolve in the mobile phase to make exactly 100 mL, and use this solution as the sample solution. Separately, weigh accurately about 10 mg of Berberine Chloride RS (separately, determine the water <2.48> in the same manner as Berberine Chloride Hydrate), dissolve in the mobile phase

to make exactly 100 mL, and use this solution as the standard solution. Perform the test with exactly 10 μ L each of the sample solution and standard solution as directed under Liquid Chromatography <2.01> according to the following conditions. Determine the peak areas, A_T and A_S , of berberine in each solution.

$$\begin{aligned} &\text{Amount (mg) of berberine (C}_{20}\text{H}_{19}\text{NO}_3) \\ &= M_S \times A_T / A_S \times 0.950 \end{aligned}$$

M_S : Amount (mg) of Berberine Chloride RS taken, calculated on the anhydrous basis

Operating conditions—

Detector: An ultraviolet absorption photometer (wavelength: 345 nm).

Column: A stainless steel column 4.6 mm in inside diameter and 25 cm in length, packed with octadecylsilanized silica gel for liquid chromatography (5 μ m in particle diameter).

Column temperature: A constant temperature of about 40°C.

Mobile phase: Dissolve 3.4 g of potassium dihydrogen phosphate and 1.7 g of sodium lauryl sulfate in 1000 mL of a mixture of water and acetonitrile (1:1).

Flow rate: Adjust so that the retention time of berberine is about 10 minutes.

System suitability—

System performance: Dissolve 1 mg each of berberine chloride and palmatin chloride in the mobile phase to make 10 mL. When the procedure is run with 10 μ L of this solution under the above operating conditions, palmatin and berberine are eluted in this order with the resolution between these peaks being not less than 1.5.

System repeatability: When the test is repeated 6 times with 10 μ L of the standard solution under the above operating conditions, the relative standard deviation of the peak area of berberine is not more than 1.5%.

Containers and storage Containers—Tight containers.

Storage—Light-resistant.

Betahistine Mesilate

ベタヒスチンメシル酸塩

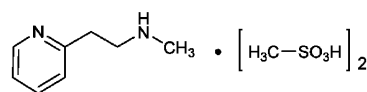

$\text{C}_8\text{H}_{12}\text{N}_2 \cdot 2\text{CH}_4\text{O}_3\text{S}$: 328.41
N-Methyl-2-pyridin-2-ylethylamine
dimethanesulfonate
[5638-76-6, Betahistine]

Betahistine Mesilate, when dried, contains not less than 98.0% and not more than 101.0% of betahistine mesilate ($\text{C}_8\text{H}_{12}\text{N}_2 \cdot 2\text{CH}_4\text{O}_3\text{S}$).

Description Betahistine Mesilate occurs as white, crystals or crystalline powder.

It is very soluble in water, freely soluble in acetic acid (100), and sparingly soluble in ethanol (99.5).

It dissolves in dilute hydrochloric acid.

It is hygroscopic.

Identification (1) Determine the absorption spectrum of a solution of Betahistine Mesilate in 0.1 mol/L hydrochloric acid (1 in 50,000) as directed under Ultraviolet-visible Spectrophotometry <2.24>, and compare the spectrum with the

Reference Spectrum: both spectra exhibit similar intensities of absorption at the same wavelengths.

(2) Determine the infrared absorption spectrum of Betahistine Mesilate, previously dried, as directed in the potassium bromide disk method under Infrared Spectrophotometry <2.25>, and compare the spectrum with the Reference Spectrum: both spectra exhibit similar intensities of absorption at the same wave numbers.

(3) A 30 mg portion of Betahistine Mesilate responds to Qualitative Tests <1.09> (2) for mesilate.

Melting point <2.60> 110 – 114°C (after drying).

Purity (1) Heavy metals <1.07>—Proceed with 1.0 g of Betahistine Mesilate according to Method 4, and perform the test. Prepare the control solution with 2.0 mL of Standard Lead Solution (not more than 20 ppm).

(2) Related substances—Dissolve 50 mg of Betahistine Mesilate in 10 mL of a mixture of water and acetonitrile (63:37), and use this solution as the sample solution. Pipet 1 mL of the sample solution, add the mixture of water and acetonitrile (63:37) to make exactly 100 mL, and use this solution as the standard solution. Perform the test with exactly 20 μ L each of the sample solution and standard solution as directed under Liquid Chromatography <2.01> according to the following conditions, and determine each peak area by the automatic integration method: the area of the peak other than betahistine obtained from the sample solution is not larger than 1/10 times the peak area of betahistine from the standard solution, and the total area of the peaks other than the peak of betahistine from the sample solution is not larger than 1/2 times the peak area of betahistine from the standard solution.

Operating conditions—

Detector: An ultraviolet absorption photometer (wavelength: 261 nm).

Column: A stainless steel column 4.6 mm in inside diameter and 15 cm in length, packed with octadecylsilanized silica gel for liquid chromatography (5 μ m in particle diameter).

Column temperature: A constant temperature of about 35°C.

Mobile phase: To 5 mL of diethylamine and 20 mL of acetic acid (100) add water to make 1000 mL. Dissolve 2.3 g of sodium lauryl sulfate in 630 mL of this solution, and add 370 mL of acetonitrile.

Flow rate: Adjust so that the retention time of betahistine is about 5 minutes.

Time span of measurement: About 3 times as long as the retention time of betahistine, beginning after the solvent peak.

System suitability—

Test for required detectability: To exactly 5 mL of the standard solution add the mixture of water and acetonitrile (63:37) to make exactly 50 mL. Confirm that the peak area of betahistine obtained with 20 μ L of this solution is equivalent to 7 to 13% of that with 20 μ L of the standard solution.

System performance: Dissolve 10 mg of betahistine mesilate and 10 mg of 2-vinylpyridine in 50 mL of the mixture of water and acetonitrile (63:37). To 2 mL of this solution add the mixture of water and acetonitrile (63:37) to make 50 mL. When the procedure is run with 20 μ L of this solution under the above operating conditions, 2-vinylpyridine and betahistine are eluted in this order with the resolution between these peaks being not less than 5.

System repeatability: When the test is repeated 6 times with 20 μ L of the standard solution under the above operating conditions, the relative standard deviation of the peak area of betahistine is not more than 1.0%

Loss on drying <2.41> Not more than 1.0% (1 g, in vacuum, phosphorus (V) oxide, 70°C, 24 hours).

Residue on ignition <2.44> Not more than 0.1% (1 g).

Assay Weigh accurately about 0.2 g of Betahistine Mesilate, previously dried, dissolve in 1 mL of acetic acid (100), add 50 mL of acetic anhydride, and titrate <2.50> with 0.1 mol/L perchloric acid VS (potentiometric titration). Perform a blank determination in the same manner, and make any necessary correction.

Each mL of 0.1 mol/L perchloric acid VS
= 16.42 mg of $C_8H_{12}N_2 \cdot 2CH_4O_3S$

Containers and storage Containers—Tight containers.

Betahistine Mesilate Tablets

ベタヒスチンメシル酸塩錠

Betahistine Mesilate Tablets contain not less than 93.0% and not more than 107.0% of the labeled amount of betahistine mesilate ($C_8H_{12}N_2 \cdot 2CH_4O_3S$: 328.41).

Method of preparation Prepare as directed under Tablets, with Betahistine Mesilate.

Identification To 5 mL of the sample solution obtained in the Assay add 0.1 mol/L hydrochloric acid TS to make 100 mL, and determine the absorption spectrum of this solution as directed under Ultraviolet-visible Spectrophotometry <2.24>: it exhibits a maximum between 259 nm and 263 nm.

Purity Related substances—Powder not less than 20 Betahistine Mesilate Tablets. To a portion of the powder, equivalent to about 50 mg of Betahistine Mesilate, add 10 mL of a mixture of water and acetonitrile (63:37), agitate for 10 minutes by sonicating, centrifuge, and use the supernatant liquid as the sample solution. Pipet 1 mL of the sample solution, add the mixture of water and acetonitrile (63:37) to make exactly 100 mL, and use this solution as the standard solution. Perform the test with exactly 20 μ L each of the sample solution and standard solution as directed under Liquid Chromatography <2.01> according to the following conditions, and determine each peak area by the automatic integration method: the area of the peak, having the relative retention time of about 1.9 to betahistine obtained from the sample solution, is not larger than 3/5 times the peak area of betahistine from the standard solution, and the total area of the peaks other than betahistine from the sample solution is not larger than the peak area of betahistine from the standard solution.

Operating conditions—

Detector, column, column temperature, mobile phase, and flow rate: Proceed as directed in the operating conditions in the Assay.

Time span of measurement: About 8 times as long as the retention time of betahistine, beginning after the solvent peak.

System suitability—

Test for required detectability: To exactly 5 mL of the standard solution add the mixture of water and acetonitrile (63:37) to make exactly 50 mL. Confirm that the peak area of betahistine obtained with 20 μ L of this solution is equivalent to 7 to 13% of that with 20 μ L of the standard solution.

System performance: Dissolve 10 mg of betahistine mesilate and 10 mg of 2-vinylpyridine in 50 mL of the mixture of

water and acetonitrile (63:37). To 2 mL of this solution add the mixture of water and acetonitrile (63:37) to make 50 mL. When the procedure is run with 20 μ L of this solution under the above operating conditions, 2-vinylpyridine and betahistine are eluted in this order with the resolution between these peaks being not less than 5.

System repeatability: When the test is repeated 6 times with 20 μ L of the standard solution under the above operating conditions, the relative standard deviation of the peak area of betahistine is not more than 1.0%.

Uniformity of dosage units <6.02> Perform the test according to the following method: it meets the requirement of the Content uniformity test.

To 1 tablet of Betahistine Mesilate Tablets add exactly V mL of 0.1 mol/L hydrochloric acid TS so that each mL contains about 0.4 mg of betahistine mesilate ($C_8H_{12}N_2 \cdot 2CH_4O_3S$), agitate for about 10 minutes by sonicating to disintegrate the tablet, then centrifuge, and use the supernatant liquid as the sample solution. Proceed as directed in the Assay.

$$\begin{aligned} \text{Amount (mg) of betahistine mesilate } (C_8H_{12}N_2 \cdot 2CH_4O_3S) \\ = M_S \times A_T/A_S \times V/250 \end{aligned}$$

M_S : Amount (mg) of betahistine mesilate for assay taken

Dissolution <6.10> When the test is performed at 50 revolutions per minute according to the Paddle method, using 900 mL of water as the dissolution medium, the dissolution rate in 15 minutes of Betahistine Mesilate Tablets is not less than 85%.

Start the test with 1 tablet of Betahistine Mesilate Tablets, withdraw not less than 20 mL of the medium at the specified minute after starting the test, and filter through a membrane filter with a pore size not exceeding 0.45 μ m. Discard not less than 10 mL of the first filtrate, pipet V mL of the subsequent filtrate, add water to make exactly V' mL so that each mL contains about 6.7 μ g of betahistine mesilate ($C_8H_{12}N_2 \cdot 2CH_4O_3S$), and use this solution as the sample solution. Separately, weigh accurately about 17 mg of betahistine mesilate for assay, previously dried under reduced pressure with phosphorous (V) oxide at 70°C for 24 hours, and dissolve in water to make exactly 100 mL. Pipet 4 mL of this solution, add water to make exactly 100 mL, and use this solution as the standard solution. Perform the test with exactly 20 μ L each of the sample solution and standard solution as directed under Liquid Chromatography <2.01> according to the following conditions, and determine the peak areas, A_T and A_S , of betahistine in each solution.

$$\begin{aligned} \text{Dissolution rate (\%)} \text{ with respect to the labeled amount} \\ \text{of betahistine mesilate } (C_8H_{12}N_2 \cdot 2CH_4O_3S) \\ = M_S \times A_T/A_S \times V'/V \times 1/C \times 36 \end{aligned}$$

M_S : Amount (mg) of betahistine mesilate for assay taken
C: Labeled amount (mg) of betahistine mesilate ($C_8H_{12}N_2 \cdot 2CH_4O_3S$) in 1 tablet

Operating conditions—

Proceed as directed in the operating conditions in the Assay.

System suitability—

System performance: When the procedure is run with 20 μ L of the standard solution under the above operating conditions, the number of theoretical plates and the symmetry factor of the peak of betahistine are not less than 2000 and not more than 1.5, respectively.

System repeatability: When the test is repeated 6 times with 20 μ L of the standard solution under the above operat-

ing conditions, the relative standard deviation of the peak area of betahistine is not more than 2.0%.

Assay Weigh accurately the mass of not less than 20 Betahistine Mesilate Tablets, and powder. Weigh accurately a portion of the powder, equivalent to about 20 mg of betahistine mesilate ($C_8H_{12}N_2 \cdot 2CH_4O_3S$), add 40 mL of 0.1 mol/L hydrochloric acid TS, agitate for 10 minutes by sonicating, and add 0.1 mol/L hydrochloric acid TS to make exactly 50 mL. Centrifuge, and use the supernatant liquid as the sample solution. Separately, weigh accurately about 0.1 g of betahistine mesilate for assay, previously dried under reduced pressure with phosphorous (V) oxide at 70°C for 24 hours, and dissolve in 0.1 mol/L hydrochloric acid TS to make exactly 50 mL. Pipet 10 mL of this solution, add 0.1 mol/L hydrochloric acid TS to make exactly 50 mL, and use this solution as the standard solution. Perform the test with exactly 5 μ L each of the sample solution and standard solution as directed under Liquid Chromatography <2.01>, according to the following conditions, and determine the peak areas, A_T and A_S , of betahistine in each solution.

$$\begin{aligned} \text{Amount (mg) of betahistine mesilate } (C_8H_{12}N_2 \cdot 2CH_4O_3S) \\ = M_S \times A_T/A_S \times 1/5 \end{aligned}$$

M_S : Amount (mg) of betahistine mesilate for assay taken

Operating conditions—

Detector: An ultraviolet absorption photometer (wavelength: 261 nm).

Column: A stainless steel column 4.6 mm in inside diameter and 15 cm in length, packed with octadecylsilanized silica gel for liquid chromatography (5 μ m in particle diameter).

Column temperature: A constant temperature of about 35°C.

Mobile phase: To 5 mL of diethylamine and 20 mL of acetic acid (100) add water to make 1000 mL. In 630 mL of this solution dissolve 2.3 g of sodium lauryl sulfate, and add 370 mL of acetonitrile.

Flow rate: Adjust so that the retention time of betahistine is about 5 minutes.

System suitability—

System performance: When the procedure is run with 5 μ L of the standard solution under the above operating conditions, the number of theoretical plates and the symmetry factor of the peak of betahistine are not less than 2000 and not more than 1.5, respectively.

System repeatability: When the test is repeated 6 times with 5 μ L of the standard solution under the above operating conditions, the relative standard deviation of the peak area of betahistine is not more than 1.0%.

Containers and storage Containers—Tight containers.

Betamethasone

ベタメタゾン

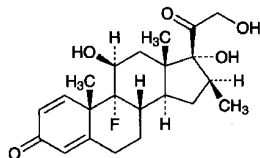

$C_{22}H_{29}FO_5$: 392.46
9-Fluoro-11 β ,17,21-trihydroxy-16 β -methylpregna-
1,4-diene-3,20-dione
[378-44-9]

Betamethasone, when dried, contains not less than 96.0% and not more than 103.0% of betamethasone ($C_{22}H_{29}FO_5$).

Description Betamethasone occurs as a white to pale yellow-white crystalline powder.

It is sparingly soluble in methanol, in ethanol (95) and in acetone, and practically insoluble in water.

Melting point: about 240°C (with decomposition).

It shows crystal polymorphism.

Identification (1) Proceed with 10 mg of Betamethasone as directed under Oxygen Flask Combustion Method <1.06>, using a mixture of 0.5 mL of 0.01 mol/L sodium hydroxide TS and 20 mL of water as the absorbing liquid: the test solution so obtained responds to Qualitative Tests <1.09> for fluoride.

(2) Dissolve 1.0 mg of Betamethasone in 10 mL of ethanol (95). Mix 2.0 mL of the solution with 10 mL of phenylhydrazinium hydrochloride TS, heat in a water bath at 60°C for 20 minutes, and cool the solution. Determine the absorption spectrum of the solution as directed under Ultraviolet-visible Spectrophotometry <2.24>, using as the blank the solution prepared with 2.0 mL of ethanol (95) in the same manner as the former solution, and compare the spectrum with the Reference Spectrum or the spectrum of a solution of Betamethasone RS prepared in the same manner as the sample solution: both spectra exhibit similar intensities of absorption at the same wavelengths.

(3) Determine the infrared absorption spectrum of Betamethasone, previously dried, as directed in the potassium bromide disk method under Infrared Spectrophotometry <2.25>, and compare the spectrum with the Reference Spectrum or the spectrum of previously dried Betamethasone RS: both spectra exhibit similar intensities of absorption at the same wave numbers. If any difference appears between the spectra, dissolve Betamethasone and Betamethasone RS in acetone, respectively, then evaporate the acetone to dryness, and repeat the test on the residues.

Optical rotation <2.49> $[\alpha]_D^{20}$: +118 – +126° (after drying, 0.1 g, methanol, 20 mL, 100 mm).

Purity (1) Heavy metals <1.07>—Proceed with 0.5 g of Betamethasone according to Method 2, and perform the test. Prepare the control solution with 1.5 mL of Standard Lead Solution (not more than 30 ppm).

(2) Related substances—Dissolve 10 mg of Betamethasone in 5 mL of a mixture of chloroform and methanol (9:1), and use this solution as the sample solution. Pipet 1 mL of the sample solution, add a mixture of chloroform and methanol (9:1) to make exactly 100 mL, and use this solution as the standard solution. Perform the test with these solutions

as directed under Thin-layer Chromatography <2.03>. Spot 5 μ L each of the sample solution and standard solution on a plate of silica gel with fluorescent indicator for thin-layer chromatography. Develop the plate with a mixture of dichloromethane, diethyl ether, methanol and water (385:75:40:6) to a distance of about 12 cm, and air-dry the plate. Examine under ultraviolet light (main wavelength: 254 nm): the spots other than the principal spot obtained from the sample solution are not more intense than the spot from the standard solution.

Loss on drying <2.41> Not more than 0.5% (0.5 g, in vacuum, phosphorus (V) oxide, 4 hours).

Residue on ignition <2.44> Not more than 0.5% (0.1 g, platinum crucible).

Assay Dissolve about 20 mg each of Betamethasone and Betamethasone RS, previously dried and accurately weighed, in methanol to make exactly 50 mL. Pipet 5 mL each of these solutions, add exactly 5 mL each of the internal standard solution, then add methanol to make 50 mL, and use these solutions as the sample solution and standard solution, respectively. Perform the test with 10 μ L each of these solutions as directed under Liquid Chromatography <2.01> according to the following conditions, and calculate the ratios, Q_T and Q_S , of the peak area of betamethasone to that of the internal standard.

$$\begin{aligned} \text{Amount (mg) of betamethasone (C}_{22}\text{H}_{29}\text{FO}_5) \\ = M_S \times Q_T / Q_S \end{aligned}$$

M_S : Amount (mg) of Betamethasone RS taken

Internal standard solution—A solution of butyl parahydroxybenzoate in methanol (1 in 1750).

Operating conditions—

Detector: An ultraviolet absorption photometer (wavelength: 240 nm).

Column: A stainless steel column about 4.0 mm in inside diameter and 15 cm in length, packed with octadecylsilanized silica gel for liquid chromatography (5 μ m in particle diameter).

Column temperature: A constant temperature of about 25°C.

Mobile phase: A mixture of water and acetonitrile (3:2).

Flow rate: Adjust so that the retention time of betamethasone is about 4 minutes.

System suitability—

System performance: When proceed the test with 10 μ L of the standard solution under the above operating conditions, betamethasone and the internal standard are eluted in this order with the resolution between these peaks being not less than 10.

System repeatability: When the test is repeated 6 times with 10 μ L of the standard solution under the above operating conditions, the relative standard deviation of the ratio of the peak area of betamethasone to that of the internal standard is not more than 1.0%.

Containers and storage Containers—Tight containers.

Storage—Light-resistant.

Betamethasone Tablets

ベタメタゾン錠

Betamethasone Tablets contain not less than 90.0% and not more than 107.0% of the labeled amount of betamethasone ($C_{22}H_{29}FO_5$; 392.46).

Method of preparation Prepare as directed under Tablets, with Betamethasone.

Identification Pulverize Betamethasone Tablets. To a portion of the powder, equivalent to 2 mg of Betamethasone, add 20 mL of methanol, shake for 5 minutes, and filter. Evaporate the filtrate on a water bath to dryness, dissolve the residue after cooling in 2 mL of methanol, filter if necessary, and use this as the sample solution. Separately, dissolve 2 mg of Betamethasone RS in 2 mL of methanol, and use this solution as the standard solution. Perform the test with these solutions as directed under Thin-layer Chromatography <2.03>. Spot 5 μ L each of the sample solution and standard solution on a plate of silica gel with fluorescent indicator for thin-layer chromatography, develop with a mixture of 1-butanol, water and acetic anhydride (3:1:1) to a distance of about 10 cm, and air-dry the plate. Examine under ultraviolet light (main wavelength: 254 nm): the principal spot obtained from the sample solution and the spot from the standard solution show the same R_f value.

Uniformity of dosage units <6.02> Perform the test according to the following method: it meets the requirement of the Content uniformity test.

To 1 tablet of Betamethasone Tablets add V mL of water so that each mL contains about 50 μ g of betamethasone ($C_{22}H_{29}FO_5$). Add exactly $2V$ mL of the internal standard solution, shake vigorously for 10 minutes, centrifuge, and use the supernatant liquid as the sample solution. Separately, weigh accurately about 20 mg of Betamethasone RS, previously dried for 4 hours in a desiccator (in vacuum, phosphorus (V) oxide), dissolve in acetonitrile to make exactly 200 mL. Pipet 5 mL of this solution, add exactly 20 mL of the internal standard solution, add 5 mL of water, and use this solution as the standard solution. Perform the test with 20 μ L each of the sample solution and standard solution as directed under Liquid Chromatography <2.01> according to the following conditions, and calculate the ratios, Q_T and Q_S , of the peak area of betamethasone to that of the internal standard.

$$\begin{aligned} & \text{Amount (mg) of betamethasone (C}_{22}\text{H}_{29}\text{FO}_5\text{)} \\ & = M_S \times Q_T/Q_S \times V/400 \end{aligned}$$

M_S : Amount (mg) of Betamethasone RS taken

Internal standard solution—A solution of butyl parahydroxybenzoate in acetonitrile (1 in 40,000).

Operating conditions—

Proceed as directed in the operating conditions in the Assay.

System suitability—

System performance: When the procedure is run with 20 μ L of the standard solution under the above operating conditions, betamethasone and the internal standard are eluted in this order with the resolution between these peaks being not less than 10.

System repeatability: When the test is repeated 6 times with 20 μ L of the standard solution under the above operating conditions, the relative standard deviation of the ratio of

the peak area of betamethasone to that of the internal standard is not more than 1.0%.

Dissolution <6.10> When the test is performed at 50 revolutions per minute according to the Paddle method, using 900 mL of water as the dissolution medium, the dissolution rate in 30 minutes of Betamethasone Tablets is not less than 85%.

Start the test with 1 tablet of Betamethasone Tablets, withdraw not less than 20 mL of the medium at the specified minute after starting the test, and filter through a membrane filter with a pore size not exceeding 0.45 μ m. Discard not less than 10 mL of the first filtrate, pipet the subsequent V mL of the filtrate, add water to make exactly V' mL so that each mL contains about 0.56 μ g of betamethasone ($C_{22}H_{29}FO_5$), and use this solution as the sample solution. Separately, weigh accurately about 28 mg of Betamethasone RS, previously dried in a desiccator (in vacuum, phosphorus (V) oxide) for 4 hours, dissolve in methanol to make exactly 100 mL. Pipet 5 mL of this solution, and add water to make exactly 100 mL. Pipet 4 mL of this solution, add water to make exactly 100 mL, and use this solution as the standard solution. Perform the test with exactly 100 μ L each of the sample solution and standard solution as directed under Liquid Chromatography <2.01> according to the following conditions, and determine the peak areas, A_T and A_S , of betamethasone in each solution.

Dissolution rate (%) with respect to the labeled amount of betamethasone ($C_{22}H_{29}FO_5$)

$$= M_S \times A_T/A_S \times V'/V \times 1/C \times 9/5$$

M_S : Amount (mg) of Betamethasone RS taken

C : Labeled amount (mg) of betamethasone ($C_{22}H_{29}FO_5$) in 1 tablet

Operating conditions—

Detector: An ultraviolet absorption photometer (wavelength: 241 nm).

Column: A stainless steel column 4.6 mm in inside diameter and 15 cm in length, packed with octadecylsilanized silica gel for liquid chromatography (5 μ m in particle diameter).

Column temperature: A constant temperature of about 25°C.

Mobile phase: A mixture of methanol and water (3:2).

Flow rate: Adjust so that the retention time of betamethasone is about 7 minutes.

System suitability—

System performance: When the procedure is run with 100 μ L of the standard solution under the above operating conditions, the number of theoretical plates and the symmetry factor of the peak of betamethasone are not less than 3000 and not more than 2.0, respectively.

System repeatability: When the test is repeated 6 times with 100 μ L of the standard solution under the above operating conditions, the relative standard deviation of the peak area of betamethasone is not more than 2.0%.

Assay Weigh accurately the mass of not less than 20 Betamethasone Tablets, and powder. Weigh accurately a portion of the powder, equivalent to about 5 mg of betamethasone ($C_{22}H_{29}FO_5$), add 25 mL of water, then add exactly 50 mL of the internal standard solution, and shake vigorously for 10 minutes. Filter through a membrane filter with pore size not exceeding 0.5 μ m, discard the first 5 mL of the filtrate, and use the subsequent filtrate as the sample solution. Separately, weigh accurately about 20 mg of Betamethasone RS, previously dried in a desiccator (in vacuum, phosphorus (V) oxide) for 4 hours, and dissolve in acetonitrile to make ex-

actly 50 mL. Pipet 5 mL of this solution, add exactly 20 mL of the internal standard solution and 5 mL of water, and use this solution as the standard solution. Perform the test with 20 μ L each of the sample solution and standard solution as directed under Liquid Chromatography <2.01> according to the following conditions, and calculate the ratios, Q_T and Q_S , of the peak area of betamethasone to that of the internal standard.

$$\begin{aligned} \text{Amount (mg) of betamethasone (C}_{22}\text{H}_{29}\text{FO}_5) \\ = M_S \times Q_T / Q_S \times 1/4 \end{aligned}$$

M_S : Amount (mg) of Betamethasone RS taken

Internal standard solution—A solution of butyl parahydroxybenzoate in acetonitrile (1 in 10,000).

Operating conditions—

Detector: An ultraviolet absorption photometer (wavelength: 240 nm).

Column: A stainless steel column 4 mm in inside diameter and 15 cm in length, packed with octadecylsilanized silica gel for liquid chromatography (5 μ m in particle diameter).

Column temperature: A constant temperature of about 25°C.

Mobile phase: A mixture of water and acetonitrile (3:2).

Flow rate: Adjust so that the retention time of betamethasone is about 4 minutes.

System suitability—

System performance: When the procedure is run with 20 μ L of the standard solution under the above operating conditions, betamethasone and the internal standard are eluted in this order with the resolution between these peaks being not less than 10.

System repeatability: When the test is repeated 6 times with 20 μ L of the standard solution under the above operating conditions, the relative standard deviation of the ratio of the peak area of betamethasone to that of the internal standard is not more than 1.0%.

Containers and storage Containers—Tight containers.

Storage—Light-resistant.

Betamethasone Dipropionate

ベタメタゾンジプロピオン酸エステル

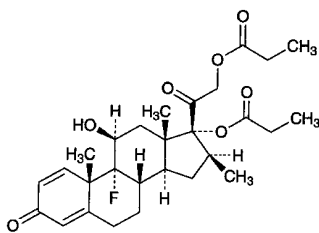

$C_{28}H_{37}FO_7$: 504.59

9-Fluoro-11 β ,17,21-trihydroxy-16 β -methylpregna-1,4-diene-3,20-dione 17,21-dipropanoate
[5593-20-4]

Betamethasone Dipropionate, when dried, contains not less than 97.0% and not more than 103.0% of betamethasone dipropionate ($C_{28}H_{37}FO_7$), and not less than 3.4% and not more than 4.1% of fluorine (F:19.00).

Description Betamethasone Dipropionate occurs as a white to pale yellow-white crystalline powder. It is odorless.

It is freely soluble in acetone and in chloroform, soluble in

methanol and in ethanol (99.5), and practically insoluble in water.

It is gradually affected by light.

Identification (1) To 1 mL of a solution of Betamethasone Dipropionate in methanol (1 in 10,000) add 4 mL of isoniazid TS, and heat on a water bath for 2 minutes: a yellow color develops.

(2) Proceed with 0.01 g of Betamethasone Dipropionate as directed under Oxygen Flask Combustion Method <1.06>, using a mixture of 0.5 mL of 0.01 mol/L sodium hydroxide TS and 20 mL of water as the absorbing liquid: the test solution so obtained responds to the Qualitative Tests <1.09> for fluoride.

(3) Determine the absorption spectrum of a solution of Betamethasone Dipropionate in methanol (3 in 200,000) as directed under Ultraviolet-visible Spectrophotometry <2.24>, and compare the spectrum with the Reference Spectrum: both spectra exhibit similar intensities of absorption at the same wavelengths.

(4) Determine the infrared absorption spectrum of Betamethasone Dipropionate, previously dried, as directed in the potassium bromide disk method under Infrared Spectrophotometry <2.25>, and compare the spectrum with the Reference Spectrum: both spectra exhibit similar intensities of absorption at the same wave numbers.

Optical rotation <2.49> $[\alpha]_D^{25}$: +84 – +89° (after drying, 50 mg, ethanol (99.5), 10 mL, 100 mm).

Melting point <2.60> 176 – 180°C

Purity (1) Fluoride—To 0.10 g of Betamethasone Dipropionate add 10.0 mL of diluted 0.01 mol/L sodium hydroxide TS (1 in 20), shake for 10 minutes, and filter through a membrane filter (0.4- μ m pore size). Place 5.0 mL of the filtrate in a 20-mL volumetric flask, and add 10 mL of a mixture of alizarin complexone TS, acetic acid-potassium acetate buffer solution (pH 4.3) and cerium (III) nitrate TS (1:1:1), add water to make 20 mL, allow to stand for 1 hour, and use this solution as the sample solution. Separately, place 1.0 mL of Standard Fluorine Solution in a 20-mL volumetric flask, add 5.0 mL of diluted 0.01 mol/L sodium hydroxide TS (1 in 20), then 10 mL of a mixture of alizarin complexone TS, acetic acid-potassium acetate buffer solution (pH 4.3) and cerium (III) nitrate TS (1:1:1), proceed in the same manner as the preparation of the sample solution, and use this solution as the standard solution. Place 5.0 mL of diluted 0.01 mol/L sodium hydroxide TS (1 in 20) in a 20-mL volumetric flask, and proceed in the same manner as the preparation of the sample solution. Using this solution as the blank, determine the absorbances of the sample solution and standard solution at 600 nm as directed under Ultraviolet-visible Spectrophotometry <2.24>: the absorbance of the sample solution is not more than that of the standard solution (not more than 0.012%).

(2) Heavy metals <1.07>—Proceed with 1.0 g of Betamethasone Dipropionate according to Method 2, and perform the test. Prepare the control solution with 2.0 mL of Standard Lead Solution (not more than 20 ppm).

(3) Related substances—Conduct this procedure without exposure to light, using light-resistant vessels. Dissolve 10 mg of Betamethasone Dipropionate in 10 mL of chloroform, and use this solution as the sample solution. Pipet 3 mL of the sample solution, add chloroform to make exactly 100 mL, and use this solution as the standard solution. Perform the test as directed under Thin-layer Chromatography <2.03> with these solutions. Spot 20 μ L each of the sample solution and standard solution on a plate of silica gel with fluorescent

indicator for thin-layer chromatography. Develop the plate with a mixture of chloroform and acetone (7:1) to a distance of about 10 cm, and air-dry the plate. Examine under ultraviolet light (main wavelength: 254 nm): the spots other than the principal spot obtained from the sample solution are not more intense than the spot from the standard solution.

Loss on drying <2.41> Not more than 1.0% (0.5 g, 105°C, 3 hours).

Residue on ignition <2.44> Not more than 0.2% (0.5 g, platinum crucible).

Assay (1) Betamethasone dipropionate—Weigh accurately about 15 mg of Betamethasone Dipropionate, previously dried, and dissolve in methanol to make exactly 100 mL. Pipet 5 mL of this solution, and dilute with methanol to exactly 50 mL. Determine the absorbance A of this solution at the wavelength of maximum absorption at about 239 nm as directed under Ultraviolet-visible Spectrophotometry <2.24>.

Amount (mg) of betamethasone dipropionate ($C_{28}H_{37}FO_7$)
 $= A/312 \times 10,000$

(2) Fluorine—Weigh accurately about 10 mg of Betamethasone Dipropionate, previously dried, and proceed as directed in the procedure of determination for fluorine under Oxygen Flask Combustion Method <1.06>, using a mixture of 0.5 mL of 0.01 mol/L sodium hydroxide TS and 20 mL of water as the absorbing liquid.

Containers and storage Containers—Tight containers.
 Storage—Light-resistant.

Betamethasone Sodium Phosphate

ベタメタゾンリン酸エステルナトリウム

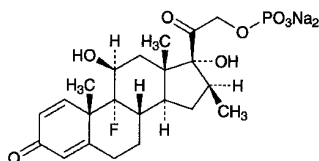

$C_{22}H_{28}FNa_2O_8P$: 516.40
 9-Fluoro-11 β ,17,21-trihydroxy-16 β -methylpregna-
 1,4-diene-3,20-dione 21-(disodium phosphate)
 [151-73-5]

Betamethasone Sodium Phosphate contains not less than 97.0% and not more than 103.0% of betamethasone sodium phosphate ($C_{22}H_{28}FNa_2O_8P$), calculated on the anhydrous basis.

Description Betamethasone Sodium Phosphate occurs as white to pale yellow-white, crystalline powder or masses. It is odorless.

It is freely soluble in water, sparingly soluble in methanol, slightly soluble in ethanol (95), and practically insoluble in diethyl ether.

It is hygroscopic.

Melting point: about 213°C (with decomposition).

Identification (1) Dissolve 2 mg of Betamethasone Sodium Phosphate in 2 mL of sulfuric acid: a brown color develops, and gradually changes to blackish brown.

(2) Prepare the test solution with 0.01 g of Betamethasone Sodium Phosphate as directed under Oxygen Flask Combustion Method <1.06>, using a mixture of 0.5 mL of

0.01 mol/L sodium hydroxide TS and 20 mL of water as an absorbing liquid: the test solution responds to Qualitative Tests <1.09> (2) for fluoride.

(3) Take 40 mg of Betamethasone Sodium Phosphate in a platinum crucible, and carbonize by heating. After cooling, add 5 drops of nitric acid, and incinerate by heating. To the residue add 10 mL of diluted nitric acid (1 in 50), and boil for several minutes. After cooling, filter if necessary, and use this solution as the sample solution. The sample solution responds to Qualitative Tests <1.09> (2) for phosphate. The sample solution neutralized with ammonia TS responds to Qualitative Tests <1.09> for sodium salt, and to Qualitative Tests <1.09> (1) and (3) for phosphate.

(4) Determine the infrared absorption spectrum of Betamethasone Sodium Phosphate, as directed in the potassium bromide disk method under Infrared Spectrophotometry <2.25>, and compare the spectrum with the Reference Spectrum or the spectrum of Betamethasone Sodium Phosphate RS: both spectra exhibit similar intensities of absorption at the same wave numbers.

Optical rotation <2.49> $[\alpha]_D^{20}$: +99 – +105° (0.1 g calculated on the anhydrous basis, water, 10 mL, 100 mm).

pH <2.54> Dissolve 0.10 g of Betamethasone Sodium Phosphate in 20 mL of water: the pH of this solution is between 7.5 and 9.0.

Purity (1) Clarity and color of solution—Dissolve 0.25 g of Betamethasone Sodium Phosphate in 10 mL of water: the solution is clear and colorless.

(2) Free phosphoric acid—Weigh accurately about 20 mg of Betamethasone Sodium Phosphate, dissolve in 20 mL of water, and use this solution as the sample solution. Separately, pipet 4 mL of Standard Phosphoric Acid Solution, add 20 mL of water, and use this solution as the standard solution. To each of the sample solution and the standard solution add exactly 7 mL of dilute sulfuric acid, exactly 2 mL of hexaammonium heptamolybdate-sulfuric acid TS and exactly 2 mL of *p*-methylaminophenol sulfate TS, shake well, and allow to stand at 20 ± 1°C for 15 minutes. To each add water to make exactly 50 mL, and allow to stand at 20 ± 1°C for 15 minutes. Perform the test with these solutions as directed under Ultraviolet-visible Spectrophotometry <2.24>, using a solution prepared with 20 mL of water in the same manner as the blank. Determine the absorbances, A_T and A_S , of each solution from the sample solution and standard solution at 730 nm: the amount of free phosphoric acid is not more than 0.5%.

Amount (%) of free phosphoric acid (H_3PO_4)
 $= A_T/A_S \times 1/M \times 10.32$

M : Amount (mg) of Betamethasone Sodium Phosphate taken, calculated on the anhydrous basis

(3) Betamethasone—Dissolve 20 mg of Betamethasone Sodium Phosphate in exactly 2 mL of methanol, and use this solution as the sample solution. Separately, dissolve 20 mg of Betamethasone RS in exactly 10 mL of methanol. Pipet 1 mL of this solution, add methanol to make exactly 20 mL, and use this solution as the standard solution. Perform the test with these solutions as directed under Thin-layer Chromatography <2.03>. Spot 5 μ L each of the sample solution and standard solution on a plate of silica gel with fluorescent indicator for thin-layer chromatography. Develop the plate with a freshly prepared mixture of 1-butanol, water and acetic anhydride (3:1:1) to a distance of about 10 cm, and air-dry the plate. Examine under ultraviolet light (main wavelength: 254 nm): the spot from the sample solution

corresponding to the spot obtained from the standard solution is not more intense than the spot from the standard solution.

Water <2.48> Not more than 10.0% (0.2 g, volumetric titration, back titration).

Assay Weigh accurately about 20 mg each of Betamethasone Sodium Phosphate and Betamethasone Sodium Phosphate RS (separately, determine the water <2.48> in the same manner as Betamethasone Sodium Phosphate), and dissolve each in methanol to make exactly 20 mL. Pipet 5 mL each of these solutions, and exactly 5 mL of the internal standard solution, then add methanol to make 50 mL, and use these solutions as the sample solution and standard solution, respectively. Perform the test with 10 μ L each of the sample solution and standard solution as directed under Liquid Chromatography <2.01> according to the following conditions, and calculate the ratios, Q_T and Q_S , of the peak area of betamethasone phosphate to that of the internal standard.

Amount (mg) of betamethasone sodium phosphate
($C_{22}H_{28}FN_2O_8P$) = $M_S \times Q_T/Q_S$

M_S : Amount (mg) of Betamethasone Sodium Phosphate RS taken, calculated on the anhydrous basis

Internal standard solution—A solution of butyl parahydroxybenzoate in methanol (1 in 5000).

Operating conditions—

Detector: An ultraviolet absorption photometer (wavelength: 254 nm).

Column: A stainless steel column 4.0 mm in inside diameter and 25 cm in length, packed with octadecylsilanized silica gel for liquid chromatography (7 μ m in particle diameter).

Column temperature: A constant temperature of about 25°C.

Mobile phase: Dissolve 1.6 g of tetra-*n*-butylammonium bromide, 3.2 g of disodium hydrogen phosphate dodecahydrate and 6.9 g of potassium dihydrogen phosphate in 1000 mL of water, and add 1500 mL of methanol.

Flow rate: Adjust so that the retention time of betamethasone phosphate is about 5 minutes.

System suitability—

System performance: When the procedure is run with 10 μ L of the standard solution under the above operating conditions, betamethasone phosphate and the internal standard are eluted in this order with the resolution between these peaks being not less than 10.

System repeatability: When the test is repeated 6 times with 10 μ L of the standard solution under the above operating conditions, the relative standard deviation of the ratios of the peak area of betamethasone phosphate to that of the internal standard is not more than 1.0%.

Containers and storage Containers—Tight containers.

Betamethasone Valerate

ベタメタゾン吉草酸エステル

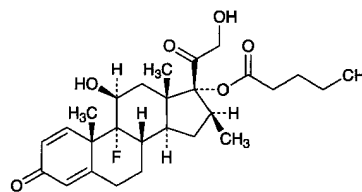

$C_{27}H_{37}FO_6$: 476.58

9-Fluoro-11 β ,17,21-trihydroxy-16 β -methylpregna-1,4-diene-3,20-dione 17-pentanoate
[2152-44-5]

Betamethasone Valerate, when dried, contains not less than 97.0% and not more than 103.0% of betamethasone valerate ($C_{27}H_{37}FO_6$).

Description Betamethasone Valerate occurs as a white crystalline powder. It is odorless.

It is freely soluble in chloroform, soluble in ethanol (95), sparingly soluble in methanol, slightly soluble in diethyl ether, and practically insoluble in water.

Melting point: about 190°C (with decomposition).

Identification (1) Proceed with 0.01 g of Betamethasone Valerate as directed under Oxygen Flask Combustion Method <1.06>, using a mixture of 0.5 mL of 0.01 mol/L sodium hydroxide TS and 20 mL of water as the absorbing liquid: the test solution so obtained responds to Qualitative Tests <1.09> for fluoride.

(2) Determine the infrared absorption spectrum of Betamethasone Valerate, previously dried, as directed in the potassium bromide disk method under Infrared Spectrophotometry <2.25>, and compare the spectrum with the Reference Spectrum or the spectrum of dried Betamethasone Valerate RS: both spectra exhibit similar intensities of absorption at the same wave numbers.

Optical rotation <2.49> $[\alpha]_D^{20}$: +77 – +83° (after drying, 0.1 g, methanol, 20 mL, 100 mm).

Purity Related substances—Conduct this procedure without exposure to daylight. Dissolve 0.02 g of Betamethasone Valerate in 5 mL of a mixture of chloroform and methanol (9:1), and use this solution as the sample solution. Pipet 1 mL of the sample solution, add a mixture of chloroform and methanol (9:1) to make exactly 50 mL, and use this solution as the standard solution. Perform the test with these solutions as directed under Thin-layer Chromatography <2.03>. Spot 5 μ L each of the sample solution and standard solution on a plate of silica gel for thin-layer chromatography. Develop the plate with a mixture of chloroform and methanol (9:1) to a distance of about 12 cm, and air-dry the plate. Spray evenly alkaline blue tetrazolium TS on the plate: the spots other than the principal spot obtained from the sample solution are not more intense than the spot from the standard solution.

Loss on drying <2.41> Not more than 0.5% (1 g, 105°C, 3 hours).

Residue on ignition <2.44> Not more than 0.2% (0.5 g, platinum crucible).

Assay Dissolve about 10 mg each of Betamethasone Valerate and Betamethasone Valerate RS, previously dried and

accurately weighed, in methanol to make exactly 100 mL. Pipet 10 mL each of these solutions, add 10 mL each of the internal standard solution, and use these solutions as the sample solution and the standard solution, respectively. Perform the test with 10 μ L each of the sample solution and standard solution as directed under Liquid Chromatography <2.01> according to the following conditions, and calculate the ratios, Q_T and Q_S , of the peak area of betamethasone valerate to that of the internal standard.

$$\begin{aligned} &\text{Amount (mg) of betamethasone valerate (C}_{27}\text{H}_{37}\text{FO}_6) \\ &= M_S \times Q_T / Q_S \end{aligned}$$

M_S : Amount (mg) of Betamethasone Valerate RS taken

Internal standard solution—A solution of isoamyl benzoate in methanol (1 in 1000).

Operating conditions—

Detector: An ultraviolet absorption photometer (wavelength: 254 nm).

Column: A stainless steel column 4.0 mm in inside diameter and 20 cm in length, packed with octadecylsilanized silica gel for liquid chromatography (7 μ m in particle diameter).

Column temperature: A constant temperature of about 25°C.

Mobile phase: A mixture of methanol and water (7:3).

Flow rate: Adjust so that the retention time of betamethasone valerate is about 10 minutes.

System suitability—

System performance: When the procedure is run with 10 μ L of the standard solution under the above operating conditions, betamethasone valerate and the internal standard are eluted in this order with the resolution between these peaks being not less than 5.

System repeatability: When the test is repeated 6 times with 10 μ L of the standard solution under the above operating conditions, the relative standard deviation of the ratio of the peak area of betamethasone valerate to that of the internal standard is not more than 1.0%.

Containers and storage Containers—Tight containers.

Betamethasone Valerate and Gentamicin Sulfate Cream

ベタメタゾン吉草酸エステル・ゲンタマイシン硫酸塩クリーム

Betamethasone Valerate and Gentamicin Sulfate Cream contains not less than 90.0% and not more than 110.0% of the labeled amount of betamethasone valerate (C₂₇H₃₇FO₆: 476.58) and not less than 90.0% and not more than 115.0% of the labeled amount of gentamicin C₁(C₂₁H₄₃N₅O₇: 477.60).

Method of preparation Prepare as directed under Creams, with Betamethasone Valerate and Gentamicin Sulfate.

Identification (1) To a quantity of Betamethasone Valerate and Gentamicin Sulfate Cream, equivalent to about 1.2 mg of Betamethasone Valerate, add 20 mL of methanol and 20 mL of hexane, shake vigorously for 10 minutes, and allow to stand. Take 15 mL of the lower layer, evaporate the layer to dryness on a water bath under a current of nitrogen. To the residue add 1 mL of ethyl acetate, mix, and use as the sample solution. Separately, dissolve about 18 mg of Betamethasone Valerate RS in 20 mL of ethyl acetate, and use this solution as the standard solution. Perform the test with

these solutions as directed under Thin-layer Chromatography <2.03>. Spot 5 μ L each of the sample solution and standard solution on a plate of silica gel for thin-layer chromatography, develop the plate with ethyl acetate to a distance of about 10 cm, and air-dry the plate. Spray evenly alkaline blue tetrazolium TS on the plate, and heat the plate at 100°C: the principal spot obtained from the sample solution and the spot from the standard solution are purple in color, and their R_f values are the same.

(2) To a quantity of Betamethasone Valerate and Gentamicin Sulfate Cream, equivalent to about 2 mg (potency) of Gentamicin Sulfate, add 20 mL of ethyl acetate and 10 mL of water, shake vigorously for 10 minutes, and centrifuge. To 3 mL of the lower layer add 1 mL of dilute sodium hydroxide TS and 2 mL of ninhydrin TS, and heat in a water bath at 90–95°C for 10 minutes: a purple to dark purple color develops.

pH <2.54> To a quantity of Betamethasone Valerate and Gentamicin Sulfate Cream, equivalent to 6 mg of Betamethasone Valerate, add 15 mL of water, and mix while warming on a water bath to make a milky liquid: the pH of the cooled liquid is between 4.0 and 6.0.

Purity Related substances—Weigh accurately an amount of Betamethasone Valerate and Gentamicin Sulfate Cream, equivalent to about 1 mg of Betamethasone Valerate, and add 10 mL of a mixture of methanol and water (7:3). Warm in a water bath at 60°C for 5 minutes, and shake vigorously for 20 minutes. Repeat this procedure 2 times. After cooling for 15 minutes with ice, centrifuge for 5 minutes, take away the bubbles from the upper surface, and filter the remaining liquid. Discard first 2 mL of the filtrate, and use the subsequent filtrate as the sample solution. Perform the test with 150 μ L of the sample solution as directed under Liquid Chromatography <2.01> according to the following conditions, determine each peak area by the automatic integration method, and calculate these amounts by the area percentage method: the amount of the substance other than betamethasone valerate is not more than 3.5%, and the total amount of them is not more than 7.0%.

Operating conditions—

Detector: An ultraviolet absorption photometer (wavelength: 240 nm).

Column: A stainless steel column 4.6 mm in inside diameter and 15 cm in length, packed with octadecylsilanized silica gel for liquid chromatography (5 μ m in particle diameter).

Column temperature: A constant temperature of about 45°C.

Mobile phase: A mixture of water, acetonitrile and methanol (12:7:1).

Flow rate: Adjust so that the retention time of betamethasone valerate is about 16 minutes.

Time span of measurement: About 2.5 times as long as the retention time of betamethasone valerate beginning after the solvent peak. The peaks of the compounding ingredients are not determined.

System suitability—

Test for required detectability: Dissolve 20 mg of Betamethasone Valerate in 100 mL of a mixture of methanol and water (7:3). To exactly 1 mL of this solution add the mixture of methanol and water (7:3) to make exactly 100 mL, and use this solution as the solution for system suitability test. To exactly 2.5 mL of the solution for system suitability test add the mixture of methanol and water (7:3) to make exactly 50 mL. Confirm that the peak area of betamethasone valerate obtained with 150 μ L of this solution is equivalent to 3.5 to 6.5% of that with 150 μ L of the solution for system suitability.

bility test.

System performance: When the procedure is run with 150 μL of the solution for system suitability test under the above operating conditions, the number of theoretical plates and the symmetry factor of the peak of betamethasone valerate are not less than 4000 and 0.8 to 1.3, respectively.

System repeatability: When the test is repeated 6 times with 150 μL of the solution for system suitability test under the above operating conditions, the relative standard deviation of the peak area of betamethasone valerate is not more than 2.0%.

Assay (1) Betamethasone valerate—Weigh accurately an amount of Betamethasone Valerate and Gentamicin Sulfate Cream, equivalent to about 1 mg of betamethasone valerate ($\text{C}_{27}\text{H}_{37}\text{FO}_6$), add 10 mL of a mixture of methanol and water (7:3), and add exactly 10 mL of the internal standard solution. After warming in a water bath at 60°C for 5 minutes, shake vigorously for 20 minutes. Repeat this procedure twice, cool with ice for 15 minutes, centrifuge for 5 minutes, then filter the supernatant liquid, discard the first 5 mL of filtrate, and use the subsequent filtrate as the sample solution. Separately, weigh accurately about 25 mg of Betamethasone Valerate RS, previously dried at 105°C for 3 hours, and dissolve in methanol to make exactly 25 mL. Pipet 5 mL of this solution, and add the mixture of methanol and water (7:3) to make exactly 50 mL. Pipet 10 mL of this solution, add exactly 10 mL of the internal standard solution, mix, and use this solution as the standard solution. Perform the test with 3 μL each of the sample solution and standard solution as directed under Liquid Chromatography <2.01> according to the following conditions, and calculate the ratios, Q_T and Q_S , of the peak area of betamethasone valerate to that of the internal standard.

$$\begin{aligned} &\text{Amount (mg) of betamethasone valerate (C}_{27}\text{H}_{37}\text{FO}_6) \\ &= M_S \times Q_T / Q_S \times 1/25 \end{aligned}$$

M_S : Amount (mg) of Betamethasone Valerate RS taken

Internal standard solution—Dissolve 20 mg of beclomethasone dipropionate in 10 mL of methanol, and add the mixture of methanol and water (7:3) to make 200 mL.

Operating conditions—

Detector: An ultraviolet absorption photometer (wavelength: 254 nm).

Column: A stainless steel column 2.1 mm in inside diameter and 10 cm in length, packed with octadecylsilanized silica gel for liquid chromatography (3.5 μm in particle diameter).

Column temperature: A constant temperature of about 25°C.

Mobile phase: A mixture of methanol and water (13:7).

Flow rate: Adjust so that the retention time of betamethasone valerate is about 16 minutes.

System suitability—

System performance: When the procedure is run with 3 μL of the standard solution under the above operating conditions, betamethasone valerate and the internal standard are eluted in this order with the resolution between these peaks being not less than 4.

System repeatability: When the test is repeated 6 times with 3 μL of the standard solution under the above operating conditions, the relative standard deviation of the ratio of the peak area of betamethasone valerate to that of the internal standard is not more than 1.0%.

(2) Gentamicin sulfate—Perform the test according to the Cylinder-plate method as directed under Microbial Assay for Antibiotics <4.02> according to the following conditions.

(i) Test organism, agar media for base layer and seed

layer, agar medium for transferring test organisms, and standard solutions—Proceed as directed in the Assay under Gentamicin Sulfate.

(ii) **Sample solutions**—Weigh accurately an amount of Betamethasone Valerate and Gentamicin Sulfate Cream, equivalent to about 1 mg (potency) of Gentamicin Sulfate, add 100 mL of 0.1 mol/L phosphate buffer solution (pH 8.0) previously warmed to about 85°C, and shake well to dissolve. After cooling, add 0.1 mol/L phosphate buffer solution (pH 8.0) to make exactly 250 mL to make the high concentration sample solution, which contains 4 μg (potency) per mL. Pipet a suitable amount of the high concentration sample solution, add 0.1 mol/L phosphate buffer solution (pH 8.0) so that each mL contains 1 μg (potency), and use this solution as the low concentration sample solution.

Containers and storage Containers—Tight containers.

Storage—Light-resistant.

Betamethasone Valerate and Gentamicin Sulfate Ointment

ベタメタゾン吉草酸エステル・ゲンタマイシン硫酸塩軟膏

Betamethasone Valerate and Gentamicin Sulfate Ointment contains not less than 95.0% and not more than 110.0% of the labeled amount of betamethasone valerate ($\text{C}_{27}\text{H}_{37}\text{FO}_6$; 476.58) and not less than 90.0% and not more than 115.0% of the labeled potency of gentamicin C_1 ($\text{C}_{21}\text{H}_{43}\text{N}_5\text{O}_7$; 477.60).

Method of preparation Prepare as directed under Ointment, with Betamethasone Valerate and Gentamicin Sulfate.

Identification (1) To a quantity of Betamethasone Valerate and Gentamicin Sulfate Ointment, equivalent to 1.2 mg of Betamethasone Valerate, add 20 mL of methanol and 20 mL of hexane, and disperse the ointment by sonicating. Shake vigorously for 5 minutes, centrifuge for 5 minutes, cool for 15 minutes with ice, and take 15 mL of the lower layer. Evaporate the layer to dryness on a water bath under a current of nitrogen. To the residue add 1 mL of ethyl acetate, sonicate, filter, if necessary, and use the filtrate as the sample solution. Separately, dissolve 18 mg of Betamethasone Valerate RS in 20 mL of ethyl acetate, and use this solution as the standard solution. Perform the test with these solutions as directed under Thin-layer Chromatography <2.03>. Spot 5 μL each of the sample solution and standard solution on a plate of silica gel for thin-layer chromatography, develop the plate with ethyl acetate to a distance of about 10 cm, and air-dry the plate. Spray evenly alkaline blue tetrazolium TS on the plate, and heat the plate at 100°C: the principal spot obtained from the sample solution and the spot from the standard solution are purple in color, and their R_f values are the same.

(2) To a quantity of Betamethasone Valerate and Gentamicin Sulfate Ointment, equivalent to 2 mg (potency) of Gentamicin Sulfate, add 20 mL of hexane and 10 mL of water, shake vigorously for 10 minutes, and centrifuge. To 3 mL of the lower layer add 1 mL of dilute sodium hydroxide TS and 2 mL of ninhydrin TS, and heat in a water bath at 90–95°C for 10 minutes: a red-brown color develops.

pH <2.54> To a quantity of Betamethasone Valerate and Gentamicin Sulfate Ointment, equivalent to 6 mg of Betamethasone Valerate, add 15 mL of water, and warm on a

water bath to dissolve. After cooling, separate the water layer: the pH of the layer is between 4.0 and 7.0.

Assay (1) Betamethasone valerate—Weigh accurately an amount of Betamethasone Valerate and Gentamicin Sulfate Ointment, equivalent to about 1 mg of betamethasone valerate ($C_{27}H_{37}FO_6$), add 10 mL of a mixture of methanol and water (7:3), and add exactly 10 mL of the internal standard solution. After warming in a water bath at 75°C for 5 minutes, shake vigorously for 10 minutes. Repeat this procedure once more, cool with ice for 15 minutes, filter, discard the first 5 mL of filtrate, and use the subsequent filtrate as the sample solution. Separately, weigh accurately about 25 mg of Betamethasone Valerate RS, previously dried at 105°C for 3 hours, and dissolve in methanol to make exactly 25 mL. Pipet 5 mL of this solution, and add the mixture of methanol and water (7:3) to make exactly 50 mL. Pipet 10 mL of this solution, add exactly 10 mL of the internal standard solution, mix, and use this solution as the standard solution. Perform the test with 3 μ L each of the sample solution and standard solution as directed under Liquid Chromatography <2.01> according to the following conditions, and calculate the ratios, Q_T and Q_S , of the peak area of betamethasone valerate to that of the internal standard.

$$\begin{aligned} \text{Amount (mg) of betamethasone valerate (C}_{27}\text{H}_{37}\text{FO}_6) \\ = M_S \times Q_T / Q_S \times 1/25 \end{aligned}$$

M_S : Amount (mg) of Betamethasone Valerate RS taken

Internal standard solution—Dissolve 20 mg of beclomethasone dipropionate in 10 mL of methanol, and add the mixture of methanol and water (7:3) to make 200 mL.

Operating conditions—

Detector: An ultraviolet absorption photometer (wavelength: 254 nm).

Column: A stainless steel column 2.1 mm in inside diameter and 10 cm in length, packed with octadecylsilanized silica gel for liquid chromatography (3.5 μ m in particle diameter).

Column temperature: A constant temperature of about 25°C.

Mobile phase: A mixture of methanol and water (13:7).

Flow rate: Adjust so that the retention time of betamethasone valerate is about 16 minutes.

System suitability—

System performance: When the procedure is run with 3 μ L of the standard solution under the above operating conditions, betamethasone valerate and the internal standard are eluted in this order with the resolution between these peaks being not less than 4.

System repeatability: When the test is repeated 6 times with 3 μ L of the standard solution under the above operating conditions, the relative standard deviation of the ratio of the peak area of betamethasone valerate to that of the internal standard is not more than 1.0%.

(2) Gentamicin sulfate—Perform the test according to the Cylinder-plate method as directed under Microbial Assay for Antibiotics <4.02> according to the following conditions.

(i) Test organism, agar media for base layer and seed layer, agar medium for transferring test organisms, and standard solutions—Proceed as directed in the Assay under Gentamicin Sulfate.

(ii) Sample solutions—Weigh accurately an amount of Betamethasone Valerate and Gentamicin Sulfate Ointment, equivalent to about 1 mg (potency) of Gentamicin Sulfate, transfer to a separator, add 50 mL of petroleum ether and exactly 100 mL of 0.1 mol/L phosphate buffer solution (pH 8.0), shake for 10 minutes, and allow to stand. Pipet a suitable amount of the water layer, add 0.1 mol/L phosphate

buffer solution (pH 8.0) to make solutions so that each mL contains 4 μ g (potency) and 1 μ g (potency), and use these solutions as the high concentration sample solution and low concentration sample solution, respectively.

Containers and storage Containers—Tight containers.

Storage—Light-resistant.

Betamipron

ベタミプロン

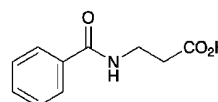

$C_{10}H_{11}NO_3$: 193.20

3-Benzoylaminopropanoic acid

[3440-28-6]

Betamipron contains not less than 99.0% and not more than 101.0% of betamipron ($C_{10}H_{11}NO_3$), calculated on the anhydrous basis.

Description Betamipron occurs as white, crystals or crystalline powder.

It is freely soluble in methanol, soluble in ethanol (99.5), and slightly soluble in water.

It dissolves in sodium hydroxide TS.

Identification (1) Determine the absorption spectrum of a solution of Betamipron in ethanol (99.5) (1 in 100,000) as directed under Ultraviolet-visible Spectrophotometry <2.24>, and compare the spectrum with the Reference Spectrum: both spectra exhibit similar intensities of absorption at the same wavelengths.

(2) Determine the infrared absorption spectrum of Betamipron as directed in the potassium bromide disk method under Infrared Spectrophotometry <2.25>, and compare the spectrum with the Reference Spectrum: both spectra exhibit similar intensities of absorption at the same wave numbers.

pH <2.54> Dissolve 0.25 g of Betamipron in 100 mL of water by warming, and cool: the pH of this solution is between 3.0 and 3.4.

Melting point <2.60> 132 – 135°C

Purity (1) Clarity and color of solution—Dissolve 1.0 g of Betamipron in 10 mL of sodium hydroxide TS: the solution is clear and colorless.

(2) Heavy metals <1.07>—Proceed with 1.0 g of Betamipron according to Method 4, and perform the test. Prepare the control solution with 1.0 mL of Standard Lead Solution (not more than 10 ppm).

(3) β -Alanine—Dissolve 0.25 g of Betamipron in 10 mL of methanol, and use this solution as the sample solution. Separately, dissolve 50 mg of β -alanine in methanol to make exactly 100 mL. Pipet 1 mL of this solution, add methanol to make exactly 10 mL, and use this solution as the standard solution. Perform the test with these solutions as directed under Thin-layer Chromatography <2.03>. Spot 5 μ L each of the sample solution and standard solution on a plate of silica gel for thin-layer chromatography, develop the plate with a mixture of methanol, ethyl acetate, ammonia solution (28) and water (200:200:63:37) to a distance of about 10 cm, and air-dry the plate. Spray evenly ninhydrin-butanol TS on the plate, and heat the plate at 105°C for 5 minutes: the spot obtained from the sample solution corresponding to the spot

from the standard solution is not more intense than the spot from the standard solution.

(4) Related substances—Dissolve 20 mg of Betamipron in 100 mL of the mobile phase, and use this solution as the sample solution. Pipet 1 mL of the sample solution, add the mobile phase to make exactly 200 mL, and use this solution as the standard solution. Perform the test with exactly 10 μ L each of the sample solution and standard solution as directed under Liquid Chromatography <2.07> according to the following conditions, and determine each peak area by the automatic integration method: the area of the peak other than betamipron from the sample solution is not larger than 2/5 times the peak area of betamipron from the standard solution, and the total area of the peaks other than betamipron from the sample solution is not larger than the peak area of betamipron from the standard solution.

Operating conditions—

Detector: An ultraviolet absorption photometer (wavelength: 225 nm).

Column: A stainless steel column 6 mm in inside diameter and 15 cm in length, packed with octadecylsilanized silica gel for liquid chromatography (5 μ m in particle diameter).

Column temperature: A constant temperature of about 40°C.

Mobile phase: Dissolve 3.12 g of sodium dihydrogen phosphate dihydrate in 800 mL of water, adjust to pH 7.0 with dilute sodium hydroxide TS, and add water to make 1000 mL. To 900 mL of this solution add 100 mL of acetonitrile.

Flow rate: Adjust so that the retention time of betamipron is about 6 minutes.

Time span of measurement: About 2 times as long as the retention time of betamipron, beginning after the solvent peak.

System suitability—

Test for required detectability: To exactly 1 mL of the standard solution add the mobile phase to make exactly 10 mL. Confirm that the peak area of betamipron obtained with 10 μ L of this solution is equivalent to 7 to 13% of that with 10 μ L of the standard solution.

System performance: Dissolve 5 mg of Betamipron and 5 mg of benzoic acid in 200 mL of the mobile phase. When the procedure is run with 10 μ L of this solution under the above operating conditions, benzoic acid and betamipron are eluted in this order with the resolution between these peaks being not less than 5.

System repeatability: When the test is repeated 6 times with 10 μ L of the standard solution under the above operating conditions, the relative standard deviation of the peak area of betamipron is not more than 2.0%.

Water <2.48> Not more than 0.5% (1 g, volumetric titration, direct titration).

Residue on ignition <2.44> Not more than 0.1% (1 g).

Assay Weigh accurately about 0.25 g of Betamipron, dissolve in 25 mL of ethanol (99.5), add 25 mL of water, and titrate <2.50> with 0.1 mol/L sodium hydroxide VS (potentiometric titration). Perform the blank determination in the same manner, and make any necessary correction.

$$\begin{aligned} \text{Each mL of 0.1 mol/L sodium hydroxide VS} \\ = 19.32 \text{ mg of } C_{10}H_{11}NO_3 \end{aligned}$$

Containers and storage Containers—Tight containers.

Betaxolol Hydrochloride

ベタキソロール塩酸塩

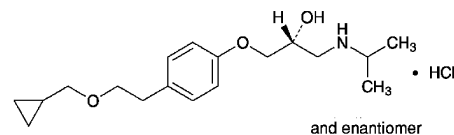

$C_{18}H_{29}NO_3 \cdot HCl$: 343.89

(2*S*)-1-[4-[2-(Cyclopropylmethoxy)ethyl]phenoxy]-3-[(1-methylethyl)amino]propan-2-ol monohydrochloride [63659-19-8]

Betaxolol Hydrochloride, when dried, contains not less than 99.0% and not more than 101.0% of betaxolol hydrochloride ($C_{18}H_{29}NO_3 \cdot HCl$).

Description Betaxolol Hydrochloride occurs as white, crystals or crystalline powder.

It is very soluble in water, and freely soluble in methanol, in ethanol (99.5) and in acetic acid (100).

Dissolve 1.0 g of Betaxolol Hydrochloride in 50 mL of water: the pH of the solution is between 4.5 and 6.5.

A solution of Betaxolol Hydrochloride (1 in 100) shows no optical rotation.

Identification (1) Determine the absorption spectrum of a solution of Betaxolol Hydrochloride in ethanol (99.5) (1 in 10,000) as directed under Ultraviolet-visible Spectrophotometry <2.24>, and compare the spectrum with the Reference Spectrum: both spectra exhibit similar intensities of absorption at the same wavelengths.

(2) Determine the infrared absorption spectrum of Betaxolol Hydrochloride as directed in the potassium chloride disk method under Infrared Spectrophotometry <2.25>, and compare the spectrum with the Reference Spectrum: both spectra exhibit similar intensities of absorption at the same wave numbers.

(3) A solution of Betaxolol Hydrochloride (1 in 10) responds to Qualitative Tests <1.09> (2) for chloride.

Melting point <2.60> 114 – 117°C

Purity (1) Clarity and color of solution—Dissolve 1.0 g of Betaxolol Hydrochloride in 10 mL of water: the solution is clear and colorless.

(2) Heavy metals <1.07>—Proceed with 2.0 g of Betaxolol Hydrochloride according to Method 4, and perform the test. Prepare the control solution with 2.0 mL of Standard Lead Solution (not more than 10 ppm).

(3) Arsenic <1.11>—Prepare the test solution with 2.0 g of Betaxolol Hydrochloride according to Method 3, and perform the test (not more than 1 ppm).

(4) Related substance I—Dissolve 0.10 g of Betaxolol Hydrochloride in 10 mL of methanol, and use this solution as the sample solution. Pipet 3 mL of the sample solution, and add methanol to make exactly 50 mL. Pipet 1 mL of this solution, add methanol to make exactly 20 mL, and use this solution as the standard solution. Perform the test with these solutions as directed under Thin-layer Chromatography <2.03>. Spot 10 μ L each of the sample solution and standard solution on a plate of silica gel for thin-layer chromatography. Develop the plate with a mixture of ethyl acetate, water and acetic acid (100) (10:3:3) to a distance of about 10 cm, and air-dry the plate. Allow the plate to stand in iodine vapor for 1 hour: the number of the spots other than the principal spot obtained from the sample solution is not more

than 3, and they are not more intense than the spot from the standard solution.

(5) Related substance II—Dissolve 0.10 g of Betaxolol Hydrochloride in 50 mL of the mobile phase, and use this solution as the sample solution. Pipet 1 mL of the sample solution, add the mobile phase to make exactly 200 mL, and use this solution as the standard solution. Perform the test with exactly 10 μ L each of the sample solution and standard solution as directed under Liquid Chromatography <2.01> according to the following conditions. Determine each peak area of both solutions by the automatic integration method: the area of the peak other than betaxolol obtained from the sample solution is not larger than the peak area of betaxolol from the standard solution, and the total area of the peaks other than the peak of betaxolol from the sample solution is not larger than 2 times the peak area of betaxolol from the standard solution.

Operating conditions—

Detector: An ultraviolet absorption photometer (wavelength: 273 nm).

Column: A stainless steel column 4.6 mm in inside diameter and 15 cm in length, packed with octylsilanized silica gel for liquid chromatography (5 μ m in particle diameter).

Column temperature: A constant temperature of about 25°C.

Mobile phase: A mixture of diluted 0.05 mol/L potassium dihydrogen phosphate TS (1 in 2) with the pH adjusted to 3.0 with 1 mol/L hydrochloric acid TS, acetonitrile and methanol (26:7:7).

Flow rate: Adjust so that the retention time of betaxolol is about 9 minutes.

Time span of measurement: About 2 times as long as the retention time of betaxolol, beginning after the solvent peak.

System suitability—

Test for required detectability: Pipet 4 mL of the standard solution, and add the mobile phase to make exactly 20 mL. Confirm that the peak area of betaxolol obtained with 10 μ L of this solution is equivalent to 14 to 26% of that with 10 μ L of the standard solution.

System performance: Dissolve 50 mg of Betaxolol Hydrochloride and 5 mg of 2-naphthol in 200 mL of the mobile phase. When the procedure is run with 10 μ L of this solution under the above operating conditions, betaxolol and 2-naphthol are eluted in this order with the resolution between these peaks being not less than 10.

System repeatability: When the test is repeated 6 times with 10 μ L of the standard solution under the above operating conditions, the relative standard deviation of the peak area of betaxolol is not more than 2.0%.

Loss on drying <2.41> Not more than 0.5% (1 g, 105°C, 4 hours).

Residue on ignition <2.44> Not more than 0.1% (1 g).

Assay Weigh accurately about 0.3 g of Betaxolol Hydrochloride, previously dried, dissolve in 30 mL of acetic acid (100), add 30 mL of acetic anhydride, and titrate <2.50> with 0.1 mol/L perchloric acid VS (potentiometric titration). Perform a blank determination in the same manner, and make any necessary correction.

Each mL of 0.1 mol/L perchloric acid VS
= 34.39 mg of C₁₈H₂₉NO₃·HCl

Containers and storage Containers—Tight containers.

Bethanechol Chloride

ベタネコール塩化物

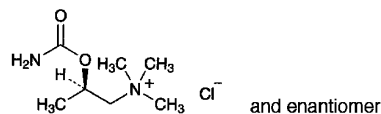

C₇H₁₇ClN₂O₂: 196.68

(2*RS*)-2-Carbamoyloxy-*N,N,N*-trimethylpropylaminium chloride
[590-63-6]

Bethanechol Chloride, when dried, contains not less than 98.0% and not more than 101.0% of bethanechol chloride (C₇H₁₇ClN₂O₂).

Description Bethanechol Chloride occurs as colorless or white crystals or a white, crystalline powder.

It is very soluble in water, freely soluble in acetic acid (100), and sparingly soluble in ethanol (99.5).

It is hygroscopic.

A solution of Bethanechol Chloride (1 in 10) shows no optical rotation.

Identification (1) To 2 mL of a solution of Bethanechol Chloride (1 in 40) add 0.1 mL of a solution of cobalt (II) chloride hexahydrate (1 in 100), then add 0.1 mL of potassium hexacyanoferrate (II) TS: A green color is produced, and almost entirely fades within 10 minutes.

(2) To 1 mL of a solution of Bethanechol Chloride (1 in 100) add 0.1 mL of iodine TS: a brown precipitate is produced, and the solution shows a greenish brown color.

(3) Determine the infrared absorption spectrum of Bethanechol Chloride as directed in the paste method under Infrared Spectrophotometry <2.25>, and compare the spectrum with the Reference Spectrum: both spectra exhibit similar intensities of absorption at the same wave numbers.

(4) A solution of Bethanechol Chloride (1 in 100) responds to Qualitative Tests <1.09> for chloride.

Melting point <2.60> 217 – 221°C (after drying).

Purity (1) Heavy metals <1.07>—Proceed with 1.0 g of Bethanechol Chloride according to Method 1, and perform the test. Prepare the control solution with 2.0 mL of Standard Lead Solution (not more than 20 ppm).

(2) Related substances—Dissolve 1.0 g of Bethanechol Chloride in 2.5 mL of water, and use this solution as the sample solution. Pipet 1 mL of the sample solution, add water to make exactly 100 mL, and use this solution as the standard solution. Perform the test with these solutions as directed under Thin-layer Chromatography <2.03>. Spot 1 μ L each of the sample solution and standard solution on a plate of cellulose for thin-layer chromatography. Develop the plate with a mixture of a solution of ammonium acetate (1 in 100), acetone, 1-butanol and formic acid (20:20:20:1) to a distance of about 10 cm, and dry the plate at 105°C for 15 minutes. Spray evenly hydrogen hexachloroplatinate (IV)-potassium iodide TS on the plate, and allow to stand for 30 minutes: the spot other than the principal spot obtained from the sample solution is not more intense than the spot from the standard solution.

Loss on drying <2.41> Not more than 1.0% (1 g, 105°C, 2 hours).

Residue on ignition <2.44> Not more than 0.1% (1 g).

Assay Weigh accurately about 0.4 g of Bethanechol Chloride, previously dried, dissolve in 2 mL of acetic acid (100), add 40 mL of acetic anhydride, and titrate <2.50> with 0.1 mol/L perchloric acid VS (potentiometric titration). Perform a blank determination in the same manner, and make any necessary correction.

Each mL of 0.1 mol/L perchloric acid VS
= 19.67 mg of $C_7H_{17}ClN_2O_2$

Containers and storage Containers—Tight containers.

Bezafibrate

ベザフィブラート

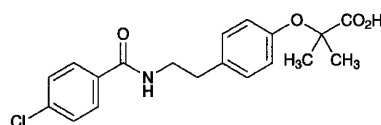

$C_{19}H_{20}ClNO_4$: 361.82

2-(4-{2-[(4-Chlorobenzoyl)amino]ethyl}phenoxy)-2-methylpropanoic acid
[41859-67-0]

Bezafibrate, when dried, contains not less than 98.5% and not more than 101.0% of bezafibrate ($C_{19}H_{20}ClNO_4$).

Description Bezafibrate occurs as a white crystalline powder.

It is freely soluble in *N,N*-dimethylformamide, soluble in methanol, slightly soluble in ethanol (99.5), and practically insoluble in water.

Identification (1) Determine the absorption spectrum of a solution of Bezafibrate in methanol (1 in 100,000) as directed under Ultraviolet-visible Spectrophotometry <2.24>, and compare the spectrum with the Reference Spectrum: both spectra exhibit similar intensities of absorption at the same wavelengths.

(2) Determine the infrared absorption spectrum of Bezafibrate, previously dried, as directed in the potassium bromide disk method under Infrared Spectrophotometry <2.25>, and compare the spectrum with the Reference Spectrum: both spectra exhibit similar intensities of absorption at the same wave numbers.

(3) Perform the test with Bezafibrate as directed under Flame Coloration Test <1.04> (2): a green color appears.

Melting point <2.60> 181 – 186°C

Purity (1) Chloride <1.03>—Dissolve 3.0 g of Bezafibrate in 15 mL of *N,N*-dimethylformamide, add water to make 60 mL, shake well, allow to stand for more than 12 hours, and filter. To 40 mL of the filtrate add 6 mL of dilute nitric acid and water to make 50 mL, and perform the test using this solution as the test solution. Prepare the control solution as follows: To 0.70 mL of 0.01 mol/L hydrochloric acid VS add 10 mL of *N,N*-dimethylformamide, 6 mL of dilute nitric acid and water to make 50 mL (not more than 0.012%).

(2) Heavy metals <1.07>—Proceed with 2.0 g of Bezafibrate according to Method 4, and perform the test. Prepare the control solution with 2.0 mL of Standard Lead Solution (not more than 10 ppm).

(3) Related substances—Dissolve 0.10 g of Bezafibrate in 35 mL of methanol, add diluted 0.5 mol/L ammonium acetate TS (1 in 50) to make 50 mL, and use this solution as the

sample solution. Pipet 1 mL of the sample solution, add 70 mL of methanol and diluted 0.5 mol/L ammonium acetate TS (1 in 50) to make exactly 100 mL, and use this solution as the standard solution. Perform the test with exactly 5 μ L each of the sample solution and standard solution as directed under Liquid Chromatography <2.01> according to the following conditions, and determine each peak area by the automatic integration method: the areas of the peaks having the relative retention times of about 0.65 and 1.86 to bezafibrate obtained from the sample solution are not larger than 1/2 times the peak area of bezafibrate from the standard solution, the area of the peaks other than bezafibrate and the peaks mentioned above from the sample solution is not larger than 1/5 times the peak area of bezafibrate from the standard solution, and the total area of the peaks other than the peak of bezafibrate from the sample solution is not larger than 3/4 times the peak area of bezafibrate from the standard solution.

Operating conditions—

Detector: An ultraviolet absorption photometer (wavelength: 230 nm).

Column: A stainless steel column 4.6 mm in inside diameter and 15 cm in length, packed with octadecylsilanized silica gel for liquid chromatography (5 μ m in particle diameter).

Column temperature: A constant temperature of about 25°C.

Mobile phase: A mixture of methanol and diluted acetic acid (100) (1 in 100) (9:4).

Flow rate: Adjust so that the retention time of bezafibrate is about 6 minutes.

Time span of measurement: About 2.5 times as long as the retention time of bezafibrate, beginning after the solvent peak.

System suitability—

Test for required detectability: Measure exactly 5 mL of the standard solution, and add a mixture of methanol and diluted 0.5 mol/L ammonium acetate TS (1 in 50) (7:3) to make exactly 50 mL. Confirm that the peak area of bezafibrate obtained with 5 μ L of this solution is equivalent to 7 to 13% of that with 5 μ L of the standard solution.

System performance: Dissolve 20 mg of Bezafibrate and 10 mg of 4-chlorobenzoate in 70 mL of methanol, and add diluted 0.5 mol/L ammonium acetate TS (1 in 50) to make 100 mL. When the procedure is run with 5 μ L of this solution under the above operating conditions, 4-chlorobenzoate and bezafibrate are eluted in this order with the resolution between these peaks being not less than 3.

System repeatability: When the test is repeated 6 times with 5 μ L of the standard solution under the above operating conditions, the relative standard deviation of the peak area of bezafibrate is not more than 2.0%.

Loss on drying <2.41> Not more than 0.5% (1 g, 105°C, 3 hours).

Residue on ignition <2.44> Not more than 0.1% (1 g).

Assay Weigh accurately about 0.7 g of Bezafibrate, previously dried, dissolve in 50 mL of ethanol (99.5), and titrate <2.50> with 0.1 mol/L sodium hydroxide VS (indicator: 3 drops of phenolphthalein TS). Perform a blank determination in the same manner, and make any necessary correction.

Each mL of 0.1 mol/L sodium hydroxide VS
= 36.18 mg of $C_{19}H_{20}ClNO_4$

Containers and storage Containers—Tight containers.

Bezafibrate Extended-release Tablets

ベザフィブラート徐放錠

Bezafibrate Extended-release Tablets contain not less than 95.0% and not more than 105.0% of the labeled amount of bezafibrate (C₁₉H₂₀ClNO₄; 361.82).

Method of preparation Prepare as directed under Tablets, with Bezafibrate.

Identification Mix well an amount of powdered Bezafibrate Extended-release Tablets, equivalent to 0.1 g of Bezafibrate, with 100 mL of methanol, and filter. To 1 mL of the filtrate add methanol to make 100 mL. Determine the absorption spectrum of this solution as directed under Ultraviolet-visible Spectrophotometry <2.24>: it exhibits a maximum between 227 nm and 231 nm.

Uniformity of dosage units <6.02> It meets the requirement of the Mass variation test.

Dissolution <6.10> When the test is performed at 50 revolutions per minute according to the Paddle method, using 900 mL of disodium hydrogen phosphate-citric acid buffer solution (pH 7.2) as the dissolution medium, the dissolution rates of a 100-mg tablet in 1.5 hours, in 2.5 hours and in 8 hours are 15 – 45%, 35 – 65% and not less than 80%, respectively, and those of a 200-mg tablet in 1.5 hours, in 2.5 hours and in 8 hours are 15 – 45%, 30 – 60% and not less than 75%, respectively.

Start the test with 1 tablet of Bezafibrate Extended-release Tablets, withdraw exactly 20 mL of the medium at the specified minutes after starting the test, and immediately fill up the dissolution medium each time with exactly 20 mL of fresh dissolution medium, previously warmed to 37 ± 0.5°C. Filter these media through a membrane filter with a pore size not exceeding 0.45 μm. Discard not less than 10 mL of the first filtrate, pipet the subsequent V mL, add the dissolution medium to make exactly V' mL so that each mL contains about 13 μg of bezafibrate (C₁₉H₂₀ClNO₄), and use these solutions as the sample solutions. Separately, weigh accurately about 66 mg of bezafibrate for assay, previously dried at 105°C for 3 hours, and dissolve in methanol to make exactly 50 mL. Pipet 2 mL of this solution, add the dissolution medium to make exactly 200 mL, and use this solution as the standard solution. Determine the absorbances, A_{T(n)} (n = 1,2,3) and A_S, of the sample solutions and standard solution at 228 nm as directed under Ultraviolet-visible Spectrophotometry <2.24>, using the dissolution medium as the blank.

Dissolution rate (%) in each case of n with respect to the labeled amount of bezafibrate (C₁₉H₂₀ClNO₄)

$$= M_S \times \left\{ \frac{A_{T(n)}}{A_S} + \sum_{i=1}^{n-1} \left(\frac{A_{T(i)}}{A_S} \times \frac{1}{45} \right) \right\} \times \frac{V'}{V} \times \frac{1}{C} \times 18$$

M_S: Amount (mg) of bezafibrate for assay taken

C: Labeled amount (mg) of bezafibrate (C₁₉H₂₀ClNO₄) in 1 tablet

Assay Weigh accurately, and powder not less than 20 Bezafibrate Extended-release Tablets. Weigh accurately a portion of the powder, equivalent to about 20 mg of bezafibrate (C₁₉H₂₀ClNO₄), add 60 mL of methanol and exactly 10 mL of the internal standard solution, and shake

for 20 minutes. Add diluted 0.5 mol/L ammonium acetate TS (1 in 50) to make 100 mL, filter, and use the filtrate as the sample solution. Separately, weigh accurately about 20 mg of bezafibrate for assay, previously dried at 105°C for 3 hours, dissolve in 60 mL of methanol, add exactly 10 mL of the internal standard solution and diluted 0.5 mol/L ammonium acetate TS (1 in 50) to make 100 mL, and use this solution as the standard solution. Perform the test with 2 μL each of the sample solution and standard solution as directed under Liquid Chromatography <2.01> according to the following conditions, and calculate the ratios, Q_T and Q_S, of the peak area of bezafibrate to that of the internal standard.

Amount (mg) of bezafibrate (C₁₉H₂₀ClNO₄) = M_S × Q_T/Q_S

M_S: Amount (mg) of bezafibrate for assay taken

Internal standard solution—A solution of 4-nitrophenol in methanol (1 in 500).

Operating conditions—

Detector: An ultraviolet absorption photometer (wavelength: 230 nm).

Column: A stainless steel column 4.6 mm in inside diameter and 15 cm in length, packed with octadecylsilanized silica gel for liquid chromatography (5 μm in particle diameter).

Column temperature: A constant temperature of about 25°C.

Mobile phase: A mixture of methanol and diluted acetic acid (100) (1 in 100) (9:4).

Flow rate: Adjust so that the retention time of bezafibrate is about 6 minutes.

System suitability—

System performance: When the procedure is run with 2 μL of the standard solution under the above operating conditions, the internal standard and bezafibrate are eluted in this order with the resolution between these peaks being not less than 4.

System repeatability: When the test is repeated 6 times with 2 μL of the standard solution under the above operating conditions, the relative standard deviation of the ratio of the peak area of bezafibrate to that of the internal standard is not more than 1.0%.

Containers and storage Containers—Tight containers.

Bicalutamide

ビカルタミド

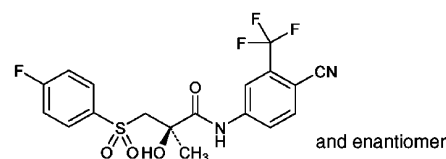

C₁₈H₁₄F₄N₂O₄S: 430.37

(2*RS*)-*N*-[4-Cyano-3-(trifluoromethyl)phenyl]-3-[(4-fluorophenyl)sulfonyl]-2-hydroxy-2-methylpropanamide [90357-06-5]

Bicalutamide contains not less than 98.0% and not more than 102.0% of bicalutamide (C₁₈H₁₄F₄N₂O₄S), calculated on the dried basis.

Description Bicalutamide occurs as a white, powder or crystalline powder.

It is freely soluble in acetone, sparingly soluble in methanol, slightly soluble in ethanol (99.5), and practically insoluble

ble in water.

A solution of Bicalutamide in acetone (1 in 100) shows no optical rotation.

Melting point <2.60> 192 – 197°C

Bicalutamide shows crystal polymorphism.

Identification (1) Determine the absorption spectrum of a solution of Bicalutamide in methanol (1 in 100,000) as directed under Ultraviolet-visible Spectrophotometry <2.24>, and compare the spectrum with the Reference Spectrum or the spectrum of a solution of Bicalutamide RS prepared in the same manner as the sample solution: both spectra exhibit similar intensities of absorption at the same wavelengths.

(2) Determine the infrared absorption spectrum of Bicalutamide as directed in the potassium bromide disk method under Infrared Spectrophotometry <2.25>, and compare the spectrum with the Reference Spectrum or the spectrum of Bicalutamide RS: both spectra exhibit similar intensities of absorption at the same wave numbers. Alternatively, perform the test by the ATR method, and compare the spectrum with the spectrum of Bicalutamide RS: both spectra exhibit similar intensities of absorption at the same wave numbers. If any difference appears between the spectra, recrystallize Bicalutamide and Bicalutamide RS with acetone, respectively, filter and dry the crystals, and perform the test by the potassium bromide disk method or the ATR method in the same manner.

Purity (1) Heavy metals <1.07>—Proceed with 2.0 g of Bicalutamide according to Method 2, and perform the test. Prepare the control solution with 2.0 mL of Standard Lead Solution (not more than 10 ppm).

(2) Related substances—Dissolve 25 mg of Bicalutamide in 25 mL of a mixture of water, acetonitrile and phosphoric acid (1000:1000:1), and use this solution as the sample solution. Pipet 1 mL of the sample solution, and add a mixture of water, acetonitrile and phosphoric acid (1000:1000:1) to make exactly 100 mL. Pipet 10 mL of this solution, add a mixture of water, acetonitrile and phosphoric acid (1000:1000:1) to make exactly 100 mL, and use this solution as the standard solution. Perform the test with exactly 10 μ L each of the sample solution and standard solution as directed under Liquid Chromatography <2.01> according to the following conditions. Determine each peak area by the automatic integration method: the peak areas of related substance M, having the relative retention time of about 0.26 to bicalutamide, related substance N, having the relative retention time of about 0.34, related substance L, having the relative retention time of about 1.03 and related substance K, having the relative retention time of about 1.13, obtained from the sample solution, are not larger than the peak area of bicalutamide from the standard solution, and the area of the peak other than bicalutamide and the peaks mentioned above from the sample solution is not larger than the peak area of bicalutamide from the standard solution. Furthermore, the total area of the peaks other than bicalutamide from the sample solution is not larger than 5 times the peak area of bicalutamide from the standard solution. For the areas of the peaks, related substance G, having the relative retention times of about 0.21 and about 0.25, related substance I, having the relative retention time of about 0.23, related substance M, related substance N, related substance O, having the relative retention time of about 0.55, related substance A, having the relative retention time of about 0.95, and related substance L, and related substance P, having the relative retention time of about 1.09 from the sample solution, multiply their correction factors, 0.5, 0.5, 0.5, 0.4, 0.7, 0.5, 1.1, 0.9 and 0.7, respectively.

Operating conditions—

Detector, column, column temperature, mobile phase and flow rate: Proceed as directed in the operating conditions in the Assay.

Time span of measurement: For 47 minutes after injection, beginning after the solvent peak.

System suitability—

Test for required detectability: Pipet 5 mL of the standard solution, and add a mixture of water, acetonitrile and phosphoric acid (1000:1000:1) to make exactly 10 mL. When the procedure is run with 10 μ L of this solution under the above operating conditions, the SN ratio of the peak of bicalutamide is not less than 10.

System performance: When the procedure is run with 10 μ L of the standard solution under the above operating conditions, the number of theoretical plates and the symmetry factor of the peak of bicalutamide are not less than 10,000 and not more than 1.5, respectively.

System repeatability: When the test is repeated 6 times with 10 μ L of the standard solution under the above operating conditions, the relative standard deviation of the peak area of bicalutamide is not more than 5.0%.

Loss on drying <2.41> Not more than 0.5% (1 g, 105°C, 4 hours).

Residue on ignition <2.44> Not more than 0.1% (1 g, platinum crucible).

Assay Weigh accurately about 25 mg each of Bicalutamide and Bicalutamide RS (separately determine the loss on drying <2.41> in the same conditions as Bicalutamide), and dissolve each in a mixture of water, acetonitrile and phosphoric acid (1000:1000:1) to make exactly 25 mL. Pipet 5 mL each of these solutions, add a mixture of water, acetonitrile and phosphoric acid (1000:1000:1) to make exactly 25 mL, and use these solutions as the sample solution and the standard solution, respectively. Perform the test with exactly 10 μ L each of the sample solution and standard solution as directed under Liquid Chromatography <2.01> according to the following conditions, and determine the peak areas, A_T and A_S , of bicalutamide in each solution.

$$\begin{aligned} &\text{Amount (mg) of bicalutamide (C}_{18}\text{H}_{14}\text{F}_4\text{N}_2\text{O}_4\text{S)} \\ &= M_S \times A_T/A_S \end{aligned}$$

M_S : Amount (mg) of Bicalutamide RS taken, calculated on the dried basis

Operating conditions—

Detector: An ultraviolet absorption photometer (wavelength: 210 nm).

Column: A stainless steel column 4 mm in inside diameter and 25 cm in length, packed with octadecylsilanized silica gel for liquid chromatography (5 μ m in particle diameter).

Column temperature: A constant temperature of about 50°C.

Mobile phase A: A mixture of diluted phosphoric acid (1 in 1000) and acetonitrile for liquid chromatography (19:1).

Mobile phase B: A mixture of acetonitrile for liquid chromatography and diluted phosphoric acid (1 in 1000) (19:1).

Flowing of mobile phase: Control the gradient by mixing the mobile phases A and B as directed in the following table.

Time after injection of sample (min)	Mobile phase A (vol%)	Mobile phase B (vol%)
0 – 20	92 → 67	8 → 33
20 – 40	67 → 50	33 → 50
40 – 47	50	50

Flow rate: 1.0 mL per minute.

System suitability—

System performance: When the procedure is run with 10 μ L of the standard solution under the above operating conditions, the number of theoretical plates and the symmetry factor of the peak of bicalutamide are not less than 10,000 and not more than 1.5, respectively.

System repeatability: When the test is repeated 6 times with 10 μ L of the standard solution under the above operating conditions, the relative standard deviation of the peak area of bicalutamide is not more than 1.0%.

Containers and storage Containers—Well-closed containers.

Others

Related substance G:

(2*RS*)-3-[(*RS*)-(4-Fluorophenyl)sulfinyl]-2-hydroxy-2-methylpropanoic acid

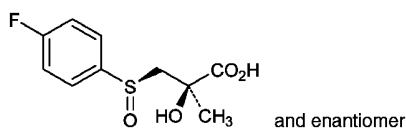

(2*RS*)-3-[(*SR*)-(4-Fluorophenyl)sulfinyl]-2-hydroxy-2-methylpropanoic acid

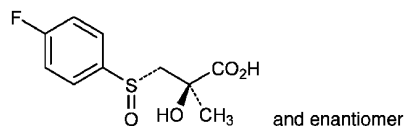

Related substance I:

(2*RS*)-3-[(2-Fluorophenyl)sulfonyl]-2-hydroxy-2-methylpropanoic acid

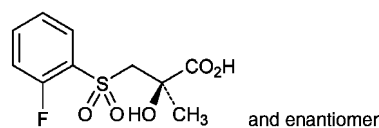

Related substance M:

(2*RS*)-3-[(4-Fluorophenyl)sulfonyl]-2-hydroxy-2-methylpropanoic acid

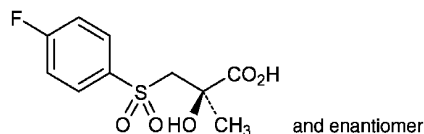

Related substance N:

1-Fluoro-4-(methylsulfonyl)benzene

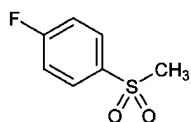

Related substance O:

(2*RS*)-3-[(4-Fluorophenyl)sulfanyl]-2-hydroxy-2-methylpropanoic acid

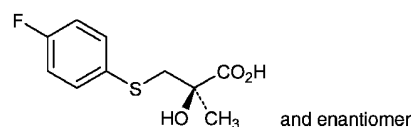

Related substance A:

(2*RS*)-*N*-[4-Cyano-3-(trifluoromethyl)phenyl]-2-hydroxy-2-methyl-3-(phenylsulfonyl)propanamide

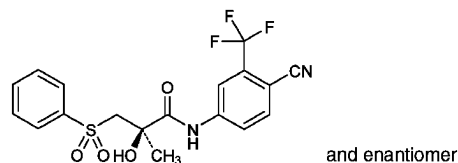

Related substance L:

(2*RS*,2'*RS*)-3,3'-Sulfonylbis{*N*-[4-cyano-3-(trifluoromethyl)phenyl]-2-hydroxy-2-methylpropanamide}

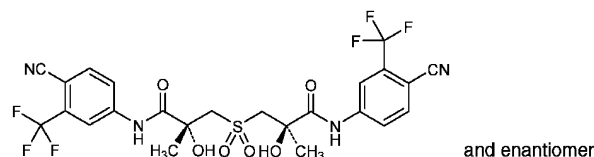

Related substance P:

(2*RS*)-3-[(4-Fluorophenyl)sulfonyl]-2-hydroxy-2-methyl-*N*-[4-nitro-3-(trifluoromethyl)phenyl]propanamide

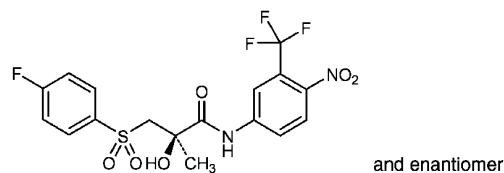

Related substance K:

(2*R*,2'*S*)-3,3'-Sulfonylbis{*N*-[4-cyano-3-(trifluoromethyl)phenyl]-2-hydroxy-2-methylpropanamide}

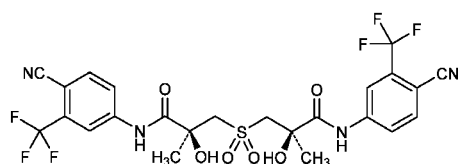

Bifonazole

ビホナゾール

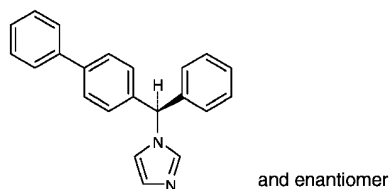

$C_{22}H_{18}N_2$: 310.39

1-[(*RS*)-(Biphenyl-4-yl)(phenyl)methyl]-1*H*-imidazole
[60628-96-8]

Bifonazole, when dried, contains not less than 98.5% of bifonazole ($C_{22}H_{18}N_2$).

Description Bifonazole occurs as a white to pale yellow powder. It is odorless and tasteless.

It is freely soluble in dichloromethane, soluble in methanol, sparingly soluble in ethanol (95), slightly soluble in diethyl ether, and practically insoluble in water.

A solution of Bifonazole in methanol (1 in 100) does not show optical rotation.

Identification (1) Determine the absorption spectrum of a solution of Bifonazole in methanol (1 in 100,000) as directed under Ultraviolet-visible Spectrophotometry <2.24>, and compare the spectrum with the Reference Spectrum: both spectra exhibit similar intensities of absorption at the same wavelengths.

(2) Determine the infrared absorption spectrum of Bifonazole, previously dried, as directed in the potassium bromide disk method under Infrared Spectrophotometry <2.25>, and compare the spectrum with the Reference Spectrum: both spectra exhibit similar intensities of absorption at the same wave numbers.

Melting point <2.60> 147 – 151°C

Purity (1) Chloride <1.03>—To 2.0 g of Bifonazole add 40 mL of water, warm for 5 minutes, and after cooling, filter. To 10 mL of the filtrate add 6 mL of dilute nitric acid and water to make 50 mL. Perform the test using this solution as the test solution. Prepare the control solution with 0.30 mL of 0.01 mol/L hydrochloric acid VS (not more than 0.021%).

(2) Sulfate <1.14>—To 10 mL of the filtrate obtained in (1) add 1 mL of dilute hydrochloric acid and water to make 50 mL. Perform the test using this solution as the test solution. Prepare the control solution with 0.50 mL of 0.005 mol/L sulfuric acid VS (0.048%).

(3) Heavy metals <1.07>—Proceed with 2.0 g of Bifonazole according to Method 2, and perform the test. Prepare the control solution with 2.0 mL of Standard Lead Solution (not more than 10 ppm).

(4) Related substances—Conduct this procedure without exposure to light, using light-resistant vessels. Dissolve 0.10 g of Bifonazole in 10 mL of methanol, and use this solution as the sample solution. Pipet 3 mL of the sample solution, and add methanol to make exactly 100 mL. Pipet 25 mL and 5 mL of this solution, add methanol to make exactly 50 mL each, and use these solutions as the standard solutions (1) and (2), respectively. Perform the test with these solutions as directed under Thin-layer Chromatography <2.03>. Spot 10 μ L each of the sample solution and standard solutions (1) and (2) on a plate of silica gel with fluorescent indicator for

thin-layer chromatography. Develop the plate with a mixture of ethyl acetate and ammonia solution (28) (49:1) to a distance of about 10 cm, and air-dry the plate. Examine under ultraviolet light (main wavelength: 254 nm): the spot with *R_f* value of about 0.20 obtained from the sample solution is not more intense than the spot from the standard solution (1). And the spots other than the spot mentioned above and the principal spot from the sample solution are not more intense than the spot from the standard solution (2).

Loss on drying <2.41> Not more than 0.5% (0.5 g, in vacuum, phosphorus (V) oxide, 2 hours).

Residue on ignition <2.44> Not more than 0.1% (1 g).

Assay Weigh accurately about 0.15 g of Bifonazole, previously dried, and dissolve in dichloromethane to make exactly 50 mL. Pipet 5 mL of this solution in a glass-stoppered conical flask, add 10 mL of water, 5 mL of dilute sulfuric acid and 25 mL of dichloromethane, and add 2 to 3 drops of a solution of methyl yellow in dichloromethane (1 in 500) as indicator, and titrate <2.50>, while shaking vigorously, with 0.01 mol/L sodium lauryl sulfate VS by a buret with 0.02-mL minimum graduation. The end point is reached when the color of the dichloromethane layer changes from yellow to orange-red after dropwise addition of 0.01 mol/L sodium lauryl sulfate VS, strong shaking, and standing for a while.

Each mL of 0.01 mol/L sodium lauryl sulfate VS
= 3.104 mg of $C_{22}H_{18}N_2$

Containers and storage Containers—Tight containers.
Storage—Light-resistant.

Biotin

ビオチン

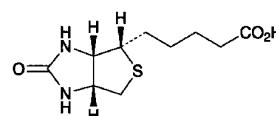

$C_{10}H_{16}N_2O_3S$: 244.31

5-[(3*aS*,4*S*,6*aR*)-2-Oxohexahydro-1*H*-thieno[3,4-*d*]imidazol-4-yl]pentanoic acid
[58-85-5]

Biotin, when dried, contains not less than 98.5% and not more than 101.0% of biotin ($C_{10}H_{16}N_2O_3S$).

Description Biotin occurs as white crystals or a white crystalline powder.

It is very slightly soluble in water and in ethanol (99.5).

It dissolves in dilute sodium hydroxide TS.

Melting point: about 231°C (with decomposition).

Identification Determine the infrared absorption spectrum of Biotin as directed in the potassium bromide disc method under Infrared Spectrophotometry <2.25>, and compare the spectrum with the Reference Spectrum: both spectra exhibit similar intensities of absorption at the same wave numbers.

Optical rotation <2.49> $[\alpha]_D^{20}$: +89 – +93° (after drying, 0.4 g, dilute sodium hydroxide TS, 20 mL, 100 mm).

Purity (1) Clarity and color of solution—Dissolve 1.0 g of Biotin in 10 mL of 0.5 mol/L sodium hydroxide TS: the solution is clear and colorless.

(2) Heavy metals <1.07>—Proceed with 2.0 g of Biotin

according to Method 2, and perform the test. Prepare the control solution with 2.0 mL of Standard Lead Solution (not more than 10 ppm).

(3) Arsenic <1.11>—Place 0.7 g of Biotin in a Kjeldahl flask, add 5 mL of nitric acid and 2 mL of sulfuric acid, place a small funnel on the mouth of the flask, and carefully heat until white fumes are evolved. After cooling, add 2 mL of nitric acid twice, heat, add 2 mL of hydrogen peroxide (30) several times, and heat until the color of the solution becomes colorless or pale yellow. After cooling, add 2 mL of saturated ammonium oxalate solution, and heat to concentrate until white fumes are evolved again. After cooling, add water to make 5 mL, and perform the test using this solution as the test solution (not more than 2.8 ppm).

(4) Related substances—Dissolve 0.10 g of Biotin in 10 mL of diluted ammonia solution (28) (7 in 100), and use this solution as the sample solution. Pipet 1 mL of the sample solution, and add diluted ammonia solution (28) (7 in 100) to make exactly 100 mL. Pipet 10 mL of this solution, add diluted ammonia solution (28) (7 in 100) to make exactly 50 mL, and use this solution as the standard solution. Perform the test with these solutions as directed under Thin-layer Chromatography <2.03>. Spot 5 μ L each of the sample solution and standard solution on a plate of silica gel for thin-layer chromatography. Develop the plate with a mixture of 1-butanol, water, and acetic acid (100) (5:2:1) to a distance of about 10 cm, air-dry the plate, and then dry for 30 minutes at 105°C. Spray the plate evenly with a mixture of a solution of 4-dimethylaminocinnamaldehyde in ethanol (99.5) (1 in 500) and a solution of sulfuric acid in ethanol (99.5) (1 in 50) (1:1): the spots other than the principal spot obtained from the sample solution are not more intense than the spot from the standard solution.

Loss on drying <2.41> Not more than 0.5% (0.5 g, 105°C, 4 hours).

Residue on ignition <2.44> Not more than 0.1% (1 g).

Assay Weigh accurately about 0.25 g of Biotin, previously dried, dissolve by adding exactly 20 mL of 0.1 mol/L sodium hydroxide VS, and titrate <2.50> the excess sodium hydroxide with 0.1 mol/L hydrochloric acid VS (indicator: 2 drops of phenolphthalein TS). Perform a blank determination in the same manner.

Each mL of 0.1 mol/L sodium hydroxide VS
= 24.43 mg of $C_{21}H_{29}NO_3S$

Containers and storage Containers—Tight containers.

Biperiden Hydrochloride

ビペリデン塩酸塩

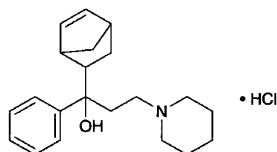

$C_{21}H_{29}NO \cdot HCl$: 347.92
1-(Bicyclo[2.2.1]hept-5-en-2-yl)-1-phenyl-3-(piperidin-1-yl)propan-1-ol monohydrochloride
[1235-82-1]

Biperiden Hydrochloride, when dried, contains not less than 99.0% of biperiden hydrochloride

($C_{21}H_{29}NO \cdot HCl$).

Description Biperiden Hydrochloride occurs as a white to brownish yellow-white crystalline powder.

It is freely soluble in formic acid, slightly soluble in water, in methanol and in ethanol (95), and practically insoluble in diethyl ether.

Melting point: about 270°C (with decomposition).

Identification (1) Dissolve 0.02 g of Biperiden Hydrochloride in 5 mL of phosphoric acid: a green color develops.

(2) Dissolve 0.01 g of Biperiden Hydrochloride in 5 mL of water by heating, cool, and add 5 to 6 drops of bromine TS: a yellow precipitate is formed.

(3) Determine the absorption spectrum of a solution of Biperiden Hydrochloride (1 in 2000) as directed under Ultraviolet-visible Spectrophotometry <2.24>, and compare the spectrum with the Reference Spectrum: both spectra exhibit similar intensities of absorption at the same wavelengths.

(4) Determine the infrared absorption spectrum of Biperiden Hydrochloride, previously dried, as directed in the potassium chloride disk method under Infrared Spectrophotometry <2.25>, and compare the spectrum with the Reference Spectrum: both spectra exhibit similar intensities of absorption at the same wave numbers.

(5) Dissolve 0.02 g of Biperiden Hydrochloride in 10 mL of water by heating, and cool: the solution responds to Qualitative Tests <1.09> for chloride.

Purity (1) Acidity or alkalinity—To 1.0 g of Biperiden Hydrochloride add 50 mL of water, shake vigorously, filter, and to 20 mL of the filtrate add 1 drop of methyl red TS: no red to yellow color develops.

(2) Heavy metals <1.07>—Proceed with 1.0 g of Biperiden Hydrochloride according to Method 2, and perform the test. Prepare the control solution with 2.0 mL of Standard Lead Solution (not more than 20 ppm).

(3) Arsenic <1.11>—Prepare the test solution with 1.0 g of Biperiden Hydrochloride according to Method 3, and perform the test (not more than 2 ppm).

(4) Related substances—Dissolve 0.10 g of Biperiden Hydrochloride in 20 mL of methanol, and use this solution as the sample solution. Pipet 1 mL of the sample solution, add methanol to make exactly 200 mL, and use this solution as the standard solution. Perform the test with these solutions as directed under Thin-layer Chromatography <2.03>. Spot 50 μ L each of the sample solution and standard solution on a plate of silica gel for thin-layer chromatography. Develop the plate with a mixture of chloroform, methanol and ammonia solution (28) (80:15:2) to a distance of about 15 cm, and air-dry the plate. Spray evenly Dragendorff's TS for spraying on the plate: the spots other than the principal spot obtained from the sample solution are not more intense than the spot from the standard solution.

Loss on drying <2.41> Not more than 0.5% (1 g, 105°C, 3 hours).

Residue on ignition <2.44> Not more than 0.1% (1 g).

Assay Weigh accurately about 0.4 g of Biperiden Hydrochloride, previously dried, dissolve in 5 mL of formic acid, add 60 mL of acetic anhydride, and titrate <2.50> with 0.1 mol/L perchloric acid VS (potentiometric titration). Perform a blank determination in the same manner, and make any necessary correction.

Each mL of 0.1 mol/L perchloric acid VS
= 34.79 mg of $C_{21}H_{29}NO \cdot HCl$

Containers and storage Containers—Well-closed contain-

ers.

Storage—Light-resistant.

Bisacodyl

ビスコジル

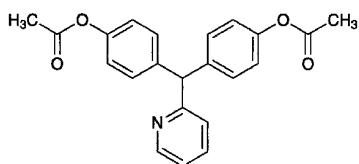

$C_{22}H_{19}NO_4$: 361.39

4,4'-(Pyridin-2-ylmethylene)bis(phenyl acetate)

[603-50-9]

Bisacodyl, when dried, contains not less than 98.5% of bisacodyl ($C_{22}H_{19}NO_4$).

Description Bisacodyl occurs as a white crystalline powder.

It is freely soluble in acetic acid (100), soluble in acetone, slightly soluble in ethanol (95) and in diethyl ether, and practically insoluble in water.

It dissolves in dilute hydrochloric acid.

Identification (1) Determine the absorption spectrum of a solution of Bisacodyl in ethanol (95) (3 in 100,000) as directed under Ultraviolet-visible Spectrophotometry <2.24>, and compare the spectrum with the Reference Spectrum or the spectrum of a solution of Bisacodyl RS prepared in the same manner as the sample solution: both spectra exhibit similar intensities of absorption at the same wavelengths.

(2) Determine the infrared absorption spectrum of Bisacodyl, previously dried, as directed in the potassium bromide disk method under Infrared Spectrophotometry <2.25>, and compare the spectrum with the Reference Spectrum or the spectrum of dried Bisacodyl RS: both spectra exhibit similar intensities of absorption at the same wave numbers.

Melting point <2.60> 132 – 136°C

Purity (1) Chloride <1.03>—Dissolve 1.0 g of Bisacodyl in 30 mL of acetone, and add 6 mL of dilute nitric acid and water to make 50 mL. Perform the test using this solution as the test solution. Prepare the control solution as follows: to 0.35 mL of 0.01 mol/L hydrochloric acid VS add 30 mL of acetone, 6 mL of dilute nitric acid and water to make 50 mL (not more than 0.012%).

(2) Sulfate <1.14>—Dissolve 1.0 g of Bisacodyl in 2 mL of dilute hydrochloric acid, and add water to make 50 mL. Perform the test using this solution as the test solution. Prepare the control solution as follows: to 0.35 mL of 0.005 mol/L sulfuric acid VS add 2 mL of dilute hydrochloric acid and water to make 50 mL (not more than 0.017%).

(3) Heavy metals <1.07>—Proceed with 2.0 g of Bisacodyl according to Method 4, and perform the test. Prepare the control solution with 2.0 mL of Standard Lead Solution (not more than 10 ppm).

(4) Related substances—Dissolve 0.20 g of Bisacodyl in 10 mL of acetone, and use this solution as the sample solution. Pipet 1 mL of the sample solution, add acetone to make exactly 200 mL, and use this solution as the standard solution. Perform the test with these solutions as directed under Thin-layer Chromatography <2.03>. Spot 10 μ L each of the sample solution and standard solution on a plate of silica gel with fluorescent indicator for thin-layer chromatography. Develop the plate with a mixture of 2-butanone, chlo-

roform and xylene (1:1:1) to a distance of about 10 cm, and air-dry the plate. Examine under ultraviolet light (main wavelength: 254 nm): the spots other than the principal spot obtained from the sample solution are not more intense than the spot from the standard solution.

Loss on drying <2.41> Not more than 0.5% (1 g, 105°C, 2 hours).

Residue on ignition <2.44> Not more than 0.1% (1 g).

Assay Weigh accurately about 0.5 g of Bisacodyl, previously dried, dissolve in 50 mL of acetic acid (100), and titrate <2.50> with 0.1 mol/L perchloric acid VS until the color of the solution changes from orange-yellow to green (indicator: 0.5 mL of *p*-naphtholbenzein TS). Perform a blank determination in the same manner, and make any necessary correction.

Each mL of 0.1 mol/L perchloric acid VS
= 36.14 mg of $C_{22}H_{19}NO_4$

Containers and storage Containers—Well-closed containers.

Bisacodyl Suppositories

ビスコジル坐剤

Bisacodyl Suppositories contain not less than 90.0% and not more than 110.0% of the labeled amount of bisacodyl ($C_{22}H_{19}NO_4$: 361.39).

Method of preparation Prepare as directed under Suppositories, with Bisacodyl.

Identification (1) To a quantity of Bisacodyl Suppositories, equivalent to 6 mg of Bisacodyl, add 20 mL of ethanol (95), warm on a water bath for 10 minutes, shake vigorously for 10 minutes, and allow to stand in ice water for 1 hour. Centrifuge the solution, filter the supernatant liquid, and to 2 mL of the filtrate add ethanol (95) to make 20 mL. Determine the absorption spectrum of the solution as directed under Ultraviolet-visible Spectrophotometry <2.24>: it exhibits a maximum between 261 nm and 265 nm.

(2) Use the filtrate obtained in (1) as the sample solution. Separately, dissolve 6 mg of Bisacodyl RS in 20 mL of ethanol (95), and use this solution as the standard solution. Perform the test with these solutions as directed under Thin-layer Chromatography <2.03>. Spot 20 μ L each of the sample solution and standard solution on a plate of silica gel with fluorescent indicator for thin-layer chromatography. Develop the plate with a mixture of 2-butanone, chloroform and xylene (1:1:1) to a distance of about 10 cm, and air-dry the plate. Examine under ultraviolet light (main wavelength: 254 nm): the spot obtained from the sample solution and that from the standard solution show the same *R_f* value.

Uniformity of dosage units <6.02> Perform the test according to the following method: it meets the requirement of the Content uniformity test.

To 1 suppository of Bisacodyl Suppositories add a suitable amount of tetrahydrofuran, warm to 40°C, and shake to dissolve. After cooling, add tetrahydrofuran to make exactly *V* mL so that each mL contains about 0.2 mg of bisacodyl ($C_{22}H_{19}NO_4$). Pipet 5 mL of this solution, and proceed as directed in the Assay.

Amount (mg) of bisacodyl ($C_{22}H_{19}NO_4$)
= $M_S \times Q_T / Q_S \times V / 50$

M_S : Amount (mg) of Bisacodyl RS taken

Internal standard solution—A solution of ethyl parahydroxybenzoate in acetonitrile (3 in 100,000).

Assay Weigh accurately not less than 20 Bisacodyl Suppositories, make them fine fragments carefully, and mix uniformly. Weigh accurately a portion of the fragments, equivalent to about 10 mg of bisacodyl ($C_{22}H_{19}NO_4$), add 40 mL of tetrahydrofuran, warm to 40°C, dissolve by shaking, cool, and add tetrahydrofuran to make exactly 50 mL. Pipet 5 mL of this solution, add exactly 5 mL of the internal standard solution, and add the mobile phase to make 100 mL. Cool this solution in ice for 30 minutes, centrifuge, filter the supernatant liquid through a membrane filter with pore size of 0.5 μ m, discard the first 10 mL of the filtrate, and use the subsequent filtrate as the sample solution. Separately, weigh accurately about 10 mg of Bisacodyl RS, previously dried at 105°C for 2 hours, and dissolve in tetrahydrofuran to make exactly 50 mL. Pipet 5 mL of this solution, proceed in the same manner as the sample solution, and use this solution as the standard solution. Perform the test with 20 μ L each of the sample solution and standard solution as directed under Liquid Chromatography <2.01> according to the following conditions, and calculate the ratios, Q_T and Q_S , of the peak area of bisacodyl to that of the internal standard.

Amount (mg) of bisacodyl ($C_{22}H_{19}NO_4$) = $M_S \times Q_T/Q_S$

M_S : Amount (mg) of Bisacodyl RS taken

Internal standard solution—A solution of ethyl parahydroxybenzoate in acetonitrile (3 in 100,000).

Operating conditions—

Detector: An ultraviolet absorption photometer (wavelength: 254 nm).

Column: A stainless steel column 4 mm in inside diameter and 30 cm in length, packed with octadecylsilanized silica gel for liquid chromatography (10 μ m in particle diameter).

Column temperature: A constant temperature of about 25°C.

Mobile phase: A mixture of 0.01 mol/L citric acid TS, acetonitrile and methanol (2:1:1).

Flow rate: Adjust so that the retention time of bisacodyl is about 8 minutes.

System suitability—

System performance: When the procedure is run with 20 μ L of the standard solution under the above operating conditions, the internal standard and bisacodyl are eluted in this order with the resolution between these peaks being not less than 2.0.

System repeatability: When the test is repeated 6 times with 20 μ L of the standard solution under the above operating conditions, the relative standard deviation of the ratios of the peak area of bisacodyl to that of the internal standard is not more than 1.0%.

Containers and storage Containers—Tight containers.

Bismuth Subgallate

次没食子酸ビスマス

Bismuth Subgallate, when dried, contains not less than 47.0% and not more than 51.0% of bismuth (Bi: 208.98).

Description Bismuth Subgallate occurs as a yellow powder. It is odorless and tasteless.

It is practically insoluble in water, in ethanol (95) and in diethyl ether.

It dissolves in dilute hydrochloric acid, in dilute nitric acid and in dilute sulfuric acid on warming. It dissolves in sodium hydroxide TS, forming a clear, yellow solution, which turns red immediately.

It is affected by light.

Identification (1) Ignite 0.5 g of Bismuth Subgallate: it chars at first, and leaves finally a yellow residue. The residue responds to Qualitative Tests <1.09> for bismuth salt.

(2) To 0.5 g of Bismuth Subgallate add 25 mL of water and 20 mL of hydrogen sulfide TS, and shake well. Filter off the blackish brown precipitate, and add 1 drop of iron (III) chloride TS to the filtrate: a blue-black color is produced.

Purity (1) Clarity of solution—Dissolve 1.0 g of Bismuth Subgallate in 40 mL of diluted sodium hydroxide TS (1 in 8): the solution is clear.

(2) Sulfate—Ignite 3.0 g of Bismuth Subgallate in a porcelain crucible, and cautiously dissolve the residue in 2.5 mL of nitric acid by warming. Pour the solution into 100 mL of water, shake, and filter. Evaporate 50 mL of the filtrate on a water bath to 15 mL. Add water to make 20 mL, filter again, and use the filtrate as the sample solution. To 5 mL of the sample solution add 2 to 3 drops of barium nitrate TS: no turbidity is produced.

(3) Nitrate—To 0.5 g of Bismuth Subgallate add 5 mL of dilute sulfuric acid and 25 mL of iron (II) sulfate TS, shake well, and filter. Superimpose carefully 5 mL of the filtrate on sulfuric acid: no red-brown color develops at the zone of contact.

(4) Ammonium—Dissolve 1.0 g of Bismuth Subgallate in 5 mL of sodium hydroxide TS, and heat: the gas evolved does not change moistened red litmus paper to blue.

(5) Copper—To 5 mL of the sample solution obtained in (2) add 1 mL of ammonia TS, and filter: no blue color develops in the filtrate.

(6) Lead—Ignite 1.0 g of Bismuth Subgallate at about 500°C in a porcelain crucible, dissolve the residue in a smallest possible amount of nitric acid added dropwise, evaporate over a low flame to dryness, and cool. Add 5 mL of a solution of potassium hydroxide (1 in 6) to the residue, boil carefully for 2 minutes, cool, and centrifuge. Take the supernatant liquid in a test tube, add 10 drops of potassium chromate TS, and acidify the solution by adding acetic acid (100) dropwise: neither turbidity nor a yellow precipitate is produced.

(7) Silver—To 5 mL of the sample solution obtained in (2) add 0.5 mL of nitric acid and 2 to 3 drops of dilute hydrochloric acid: no turbidity is produced.

(8) Alkaline earth metals and alkali metals—Boil 1.0 g of Bismuth Subgallate with 40 mL of diluted acetic acid (31) (1 in 2) for 2 minutes, cool, add water to make 40 mL, and filter. To 20 mL of the filtrate add 2 mL of dilute hydrochloric acid, boil, immediately pass hydrogen sulfide thoroughly through the solution, filter the precipitate produced, and wash with water. Combine the filtrate and the washings, add 5 drops of sulfuric acid, and evaporate to dryness. Ignite as directed under Residue on Ignition <2.44>: the mass of the residue is not more than 5.0 mg.

(9) Arsenic <1.11>—Mix well 0.20 g of Bismuth Subgallate with 0.20 g of calcium hydroxide, and ignite the mixture. Dissolve the residue in 5 mL of dilute hydrochloric acid, use this solution as the test solution, and perform the test (not more than 10 ppm).

(10) Gallic acid—To 1.0 g of Bismuth Subgallate add 20 mL of ethanol (95), shake for 1 minute, and filter.

Evaporate the filtrate on a water bath to dryness: the mass of the residue is not more than 5.0 mg.

Loss on drying <2.41> Not more than 6.0% (1 g, 105°C, 3 hours).

Assay Weigh accurately about 0.5 g of Bismuth Subgallate, previously dried, ignite at about 500°C for 30 minutes, and cool. Dissolve the residue in 5 mL of diluted nitric acid (2 in 5) by warming, and add water to make exactly 100 mL. Measure exactly 30 mL of this solution, add 200 mL of water, and titrate <2.50> with 0.02 mol/L disodium dihydrogen ethylenediamine tetraacetate VS until the color of the solution changes from red-purple to yellow (indicator: 2 to 3 drops of xylenol orange TS).

Each mL of 0.02 mol/L disodium dihydrogen ethylenediamine tetraacetate VS
= 4.180 mg of Bi

Containers and storage Containers—Well-closed containers.

Storage—Light-resistant.

Bismuth Subnitrate

次硝酸ビスマス

Bismuth Subnitrate, when dried, contains not less than 71.5% and not more than 74.5% of bismuth (Bi: 208.98).

Description Bismuth Subnitrate occurs as a white powder.

It is practically insoluble in water, in ethanol (95) and in diethyl ether.

It readily dissolves in hydrochloric acid and in nitric acid without effervescence.

It is slightly hygroscopic, and changes moistened blue litmus paper to red.

Identification Bismuth Subnitrate responds to Qualitative Tests <1.09> for bismuth salt and nitrate.

Purity (1) Chloride <1.03>—Dissolve 0.7 g of Bismuth Subnitrate in 2 mL of water and 2 mL of nitric acid, and add 6 mL of dilute nitric acid and water to make 50 mL. Perform the test using this solution as the test solution. Prepare the control solution as follows: evaporate 2 mL of nitric acid on a water bath to dryness, add 0.70 mL of 0.01 mol/L hydrochloric acid VS, 6 mL of dilute nitric acid and water to make 50 mL (not more than 0.035%).

(2) Sulfate—Dissolve 3.0 g of Bismuth Subnitrate in 3.0 mL of warmed nitric acid, pour this solution into 100 mL of water, shake, and filter. Concentrate the filtrate on a water bath to 30 mL, filter, and use this filtrate as the sample solution. To 5 mL of the sample solution add 2 to 3 drops of barium nitrate TS: no turbidity is produced.

(3) Ammonium—Boil 0.10 g of bismuth Subnitrate with 5 mL of sodium hydroxide TS: the gas evolved does not change moistened red litmus paper to blue.

(4) Copper—To 5 mL of the sample solution obtained in (2) add 2 mL of ammonia TS, and filter: no blue color develops.

(5) Lead—To 1.0 g of Bismuth Subnitrate add 5 mL of a solution of sodium hydroxide (1 in 6), boil carefully for 2 minutes, cool and centrifuge. Transfer the supernatant liquid to a test tube, add 10 drops of potassium chromate TS, and add dropwise acetic acid (31) to render the solution acid: no turbidity or yellow precipitate is produced.

(6) Silver—To 5 mL of the sample solution obtained in (2) add 0.5 mL of nitric acid and 2 to 3 drops of dilute hydrochloric acid: no turbidity is produced.

(7) Alkaline earth metals and alkali metals—Boil 2.0 g of Bismuth Subnitrate with 40 mL of diluted acetic acid (31) (1 in 2) for 2 minutes, cool, add water to make 40 mL, and filter. To 20 mL of the filtrate add 2 mL of dilute hydrochloric acid, boil, immediately pass hydrogen sulfide thoroughly through the solution, filter, and wash the residue with water. Combine the filtrate and the washings, add 5 drops of sulfuric acid, evaporate to dryness, and ignite as directed under Residue on Ignition <2.44>: the residue is not exceed 5.0 mg

(8) Arsenic <1.11>—To 0.20 g of Bismuth Subnitrate add 2 mL of sulfuric acid, heat until white fumes evolve, dilute cautiously with water to 5 mL, use this solution as the test solution, and perform the test (not more than 10 ppm).

Loss on drying <2.41> Not more than 3.0% (2 g, 105°C, 2 hours).

Assay Weigh accurately about 0.4 g of Bismuth Subnitrate, previously dried, dissolve in 5 mL of diluted nitric acid (2 in 5) by warming, and add water to make exactly 100 mL. Pipet 25 mL of the solution, add 200 mL of water and titrate <2.50> with 0.02 mol/L disodium dihydrogen ethylenediamine tetraacetate VS until the color of the solution changes from red-purple to yellow (indicator: 5 drops of xylenol orange TS)

Each mL of 0.02 mol/L disodium dihydrogen ethylenediamine tetraacetate VS
= 4.180 mg of Bi

Containers and storage Containers—Well-closed containers.

Bisoprolol Fumarate

ビソプロロール fumarate

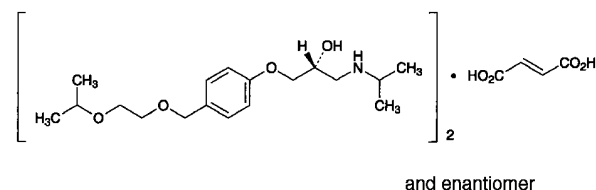

$(C_{18}H_{31}NO_4)_2 \cdot C_4H_4O_4$: 766.96

(2*RS*)-1-(4-[(2-(1-Methylethoxy)ethoxy)methyl]phenoxy)-3-[(1-methylethyl)amino]propan-2-ol hemifumarate [104344-23-2]

Bisoprolol Fumarate, when dried, contains not less than 98.5% and not more than 101.0% of bisoprolol fumarate [$(C_{18}H_{31}NO_4)_2 \cdot C_4H_4O_4$].

Description Bisoprolol Fumarate occurs as white crystals or a white crystalline powder.

It is very soluble in water and in methanol, and freely soluble in ethanol (99.5) and in acetic acid (100).

A solution of Bisoprolol Fumarate (1 in 10) shows no optical rotation.

Identification (1) Determine the absorption spectrum of a solution of Bisoprolol Fumarate in methanol (1 in 10,000) as directed under Ultraviolet-visible Spectrophotometry <2.24>, and compare the spectrum with the Reference Spectrum: both spectra exhibit similar intensities of absorption at the

same wavelengths.

(2) Determine the infrared absorption spectrum of Bisoprolol Fumarate as directed in the potassium bromide disc method under Infrared Spectrophotometry <2.25>, and compare the spectrum with the Reference Spectrum: both spectra exhibit similar intensities of absorption at the same wave numbers.

Melting point <2.60> 101 – 105°C

Purity (1) Heavy metals <1.07>—Proceed with 2.0 g of Bisoprolol Fumarate according to Method 2, and perform the test. Prepare the control solution with 2.0 mL of Standard Lead Solution (not more than 10 ppm).

(2) Related substances—Dissolve 50 mg of Bisoprolol Fumarate in 100 mL of a mixture of water and acetonitrile (4:1), and use this solution as the sample solution. Pipet 1 mL of the sample solution, add the mixture of water and acetonitrile (4:1) to make exactly 100 mL, and use this solution as the standard solution. Perform the test with exactly 20 μ L each of the sample solution and standard solution as directed under Liquid Chromatography <2.01> according to the following conditions. Determine each peak area of both solutions by the automatic integration method: the area of the peaks other than bisoprolol obtained from the sample solution is not larger than 1/2 times the peak area of bisoprolol from the standard solution. Furthermore, the total of the areas of peaks other than bisoprolol from the sample solution is not larger than the peak area of bisoprolol from the standard solution.

Operating conditions—

Detector: An ultraviolet absorption photometer (wavelength: 225 nm).

Column: A stainless steel column 4.6 mm in inside diameter and 15 cm in length, packed with octylsilylated silica gel for liquid chromatography (5 μ m in particle diameter).

Column temperature: A constant temperature of about 40°C.

Mobile phase: Dissolve 4.08 g of potassium dihydrogen phosphate in 1000 mL of water, and adjust to pH 2.5 with phosphoric acid. To 800 mL of this solution add 200 mL of acetonitrile.

Flow rate: Adjust so that the retention time of bisoprolol is about 8 minutes.

Time span of measurement: About 2 times as long as the retention time of bisoprolol, beginning after the fumaric acid peak.

System suitability—

Test for required detectability: Pipet 2 mL of the standard solution, and add a mixture of water and acetonitrile (4:1) to make exactly 20 mL. Confirm that the peak area of bisoprolol obtained with 20 μ L of this solution is equivalent to 7 to 13% of that with 20 μ L of the standard solution.

System performance: When the procedure is run with 20 μ L of the standard solution under the above operating conditions, the number of theoretical plates and the symmetry factor of the peak of bisoprolol are not less than 5000 and not more than 1.5, respectively.

System repeatability: When the test is repeated 6 times with 20 μ L of the standard solution under the above operating conditions, the relative standard deviation of the peak area of bisoprolol is not more than 1.5%.

Loss on drying <2.41> Not more than 0.5% (1 g, in vacuum, phosphorus (V) oxide, 80°C, 5 hours).

Residue on ignition <2.44> Not more than 0.1% (1 g).

Assay Weigh accurately about 0.6 g of Bisoprolol

Fumarate, previously dried, dissolve in 70 mL of acetic acid (100), and titrate <2.50> with 0.1 mol/L perchloric acid VS (indicator: 2 drops of crystal violet TS). The endpoint of titration is when the purple color of the solution turns blue and then blue-green. Perform a blank determination in the same manner, and make any necessary correction.

Each mL of 0.1 mol/L perchloric acid VS
= 38.35 mg of $(C_{18}H_{31}NO_4)_2 \cdot C_4H_4O_4$

Containers and storage Containers—Tight containers.

Bisoprolol Fumarate Tablets

ビソプロロール fumarate 塩錠

Bisoprolol Fumarate Tablets contain not less than 95.0% and not more than 105.0% of the labeled amount of bisoprolol fumarate [$(C_{18}H_{31}NO_4)_2 \cdot C_4H_4O_4$; 766.96].

Method of preparation Prepare as directed under Tablets, with Bisoprolol Fumarate.

Identification To a quantity of powdered Bisoprolol Fumarate Tablets, equivalent to 10 mg of Bisoprolol Fumarate, add 60 mL of methanol, shake vigorously for 10 minutes, add methanol to make 100 mL, and filter through a membrane filter with a pore size not exceeding 0.45 μ m. Determine the absorption spectrum of the filtrate as directed under Ultraviolet-visible Spectrophotometry <2.24>: it exhibits a maximum between 271 nm and 275 nm.

Purity Related substances—This is applied to 0.625-mg tablets. Shake vigorously for 10 minutes a portion of powdered Bisoprolol Fumarate Tablets, equivalent to 5 mg of Bisoprolol Fumarate, with exactly 20 mL of a mixture of water and acetonitrile (3:1), filter through a membrane filter with a pore size not exceeding 0.45 μ m. Discard the first 3 mL of the filtrate, and use the subsequent filtrate as the sample solution. Perform the test with 20 μ L of the sample solution as directed under Liquid Chromatography <2.01> according to the following conditions. Determine each peak area by the automatic integration method, and calculate the amount of the peak other than bisoprolol and the peak having the relative retention time of about 0.8 to bisoprolol by the area percentage method: the amount of the two peaks, having relative retention time of about 1.2 and about 3.8 to bisoprolol, are not more than 1.0%, respectively, the amount of the peak other than the peaks mentioned above is not more than 0.2%, and the total amount of the peaks other than bisoprolol is not more than 2.5%. For the area of the peak, having the relative retention time of about 1.2 to bisoprolol, multiply the correction factor 5.

Operating conditions—

Detector, column, column temperature, and flow rate: Proceed as directed in the operating conditions in the Assay.

Mobile phase: Dissolve 4.08 g of potassium dihydrogen phosphate in water to make 1000 mL, and adjust to pH 2.5 with phosphoric acid. To 750 mL of this solution add 250 mL of acetonitrile.

Time span of measurement: About 5 times as long as the retention time of bisoprolol, beginning after the peak of fumaric acid.

System suitability—

Test for required detectability: To 1 mL of the sample solution add a mixture of water and acetonitrile (3:1) to make 100 mL, and use this solution as the solution for system

suitability test. Pipet 2 mL of the solution for system suitability test, and add a mixture of water and acetonitrile (3:1) to make exactly 20 mL. Confirm that the peak area of bisoprolol obtained with 20 μ L of this solution is equivalent to 7 to 13% of that with 20 μ L of the solution for system suitability test.

System performance: When the procedure is run with 20 μ L of the solution for system suitability test under the above operating conditions, the number of theoretical plates and the symmetry factor of the peak of bisoprolol are not less than 5000 and not more than 2.0, respectively.

System repeatability: When the test is repeated 6 times with 20 μ L of the solution for system suitability test under the above operating conditions, the relative standard deviation of the peak area of bisoprolol is not more than 1.5%.

Uniformity of dosage units <6.02> Perform the test according to the following method: it meets the requirement of the Content uniformity test.

Take 1 tablet of Bisoprolol Fumarate Tablets, disintegrate by adding 8 mL of water, and add water to make exactly 10 mL, and then filter through a membrane filter with a pore size not exceeding 0.45 μ m. Discard the first 3 mL of the filtrate, pipet V mL of the subsequent filtrate, add water to make exactly V' mL so that each mL contains about 62.5 μ g of bisoprolol fumarate [(C₁₈H₃₁NO₄)₂·C₄H₄O₄], and use this solution as the sample solution. Separately, weigh accurately about 20 mg of bisoprolol fumarate for assay, previously dried under reduced pressure at 80°C for 5 hours, using phosphorus (V) oxide as a desiccant, and dissolve in water to make exactly 200 mL. Pipet 15 mL of this solution, add water to make exactly 25 mL, and use this solution as the standard solution. Determine the absorbances, A_T and A_S , at 271.5 nm of the sample solution and standard solution as directed under Ultraviolet-visible Spectrophotometry <2.24>.

$$\begin{aligned} &\text{Amount (mg) of bisoprolol fumarate} \\ &[(C_{18}H_{31}NO_4)_2 \cdot C_4H_4O_4] \\ &= M_S \times A_T/A_S \times V'/V \times 3/100 \end{aligned}$$

M_S : Amount (mg) of bisoprolol fumarate for assay taken

Dissolution <6.10> When the test is performed at 50 revolutions per minute according to the Paddle method, using 900 mL of 2nd fluid for dissolution test as the dissolution medium, the dissolution rate in 30 minutes of Bisoprolol Fumarate Tablets is not less than 85%.

Start the test with 1 tablet of Bisoprolol Fumarate Tablets, withdraw not less than 20 mL of the medium at the specified minute after starting the test, and filter through a membrane filter with a pore size not exceeding 0.45 μ m. Discard not less than 10 mL of the first filtrate, pipet V mL of the subsequent filtrate, add the dissolution medium to make exactly V' mL so that each mL contains about 0.7 μ g of bisoprolol fumarate [(C₁₈H₃₁NO₄)₂·C₄H₄O₄], and use this solution as the sample solution. Separately, weigh accurately about 14 mg of bisoprolol fumarate for assay, previously dried in vacuum at 80°C for 5 hours, using phosphorus (V) oxide as a desiccant, and dissolve in the dissolution medium to make exactly 100 mL. Pipet 1 mL of this solution, add the dissolution medium to make exactly 200 mL, and use this solution as the standard solution. Perform the test with exactly 50 μ L each of the sample solution and standard solution as directed under Liquid Chromatography <2.01>, and determine the peak areas, A_T and A_S , of bisoprolol in each solution.

$$\begin{aligned} &\text{Dissolution rate (\%)} \text{ with respect to the labeled amount} \\ &\text{of bisoprolol fumarate [(C}_{18}\text{H}_{31}\text{NO}_4)_2 \cdot \text{C}_4\text{H}_4\text{O}_4] \\ &= M_S \times A_T/A_S \times V'/V \times 1/C \times 9/2 \end{aligned}$$

M_S : Amount (mg) of bisoprolol fumarate for assay taken
C: Labeled amount (mg) of bisoprolol fumarate [(C₁₈H₃₁NO₄)₂·C₄H₄O₄] in 1 tablet

Operating conditions—

Detector, column, column temperature, and flow rate: Proceed as directed in the operating conditions in the Assay.

Mobile phase: Dissolve 4.08 g of potassium dihydrogen phosphate in 1000 mL of water, and adjust to pH 2.5 with phosphoric acid. To 750 mL of this solution add 250 mL of acetonitrile.

System suitability—

System performance: When the procedure is run with 50 μ L of the standard solution under the above operating conditions, the number of theoretical plates and the symmetry factor of the peak of bisoprolol are not less than 3000 and not more than 2.0, respectively.

System repeatability: When the test is repeated 6 times with 50 μ L of the standard solution under the above operating conditions, the relative standard deviation of the peak area of bisoprolol is not more than 2.0%.

Assay Weigh accurately not less than 20 Bisoprolol Fumarate Tablets and powder. Weigh accurately a portion of the powder, equivalent to about 20 mg of bisoprolol fumarate [(C₁₈H₃₁NO₄)₂·C₄H₄O₄], add 70 mL of a mixture of water and acetonitrile (3:1) and exactly 10 mL of the internal standard solution, shake vigorously for 10 minutes, and add the mixture of water and acetonitrile (3:1) to make 100 mL. Filter this solution through a membrane filter with a pore size not exceeding 0.45 μ m, discard the first 3 mL of the filtrate, and use the subsequent filtrate as the sample solution. Separately, weigh accurately about 20 mg of bisoprolol fumarate for assay, previously dried in vacuum at 80°C for 5 hours using phosphorus (V) oxide as the desiccant, add exactly 10 mL of the internal standard solution, dissolve in the mixture of water and acetonitrile (3:1) to make 100 mL, and use this solution as the standard solution. Perform the test with 20 μ L each of the sample solution and standard solution as directed under Liquid Chromatography <2.01> according to the following conditions, and calculate the ratios, Q_T and Q_S , of the peak area of bisoprolol to that of the internal standard.

$$\begin{aligned} &\text{Amount (mg) of bisoprolol fumarate [(C}_{18}\text{H}_{31}\text{NO}_4)_2 \cdot \text{C}_4\text{H}_4\text{O}_4] \\ &= M_S \times Q_T/Q_S \end{aligned}$$

M_S : Amount (mg) of bisoprolol fumarate for assay taken

Internal standard solution—A solution of isopropyl parahydroxybenzoate in the mixture of water and acetonitrile (3:1) (1 in 250).

Operating conditions—

Detector: An ultraviolet absorption photometer (wavelength: 225 nm).

Column: A stainless steel column 4.6 mm in inside diameter and 15 cm in length, packed with octylsilylated silica gel for liquid chromatography (5 μ m in particle diameter).

Column temperature: A constant temperature of about 40°C.

Mobile phase: Dissolve 4.08 g of potassium dihydrogen phosphate in 1000 mL of water, and adjust to pH 2.5 with phosphoric acid. To 800 mL of this solution add 200 mL of acetonitrile.

Flow rate: Adjust so that the retention time of bisoprolol is about 8 minutes.

System suitability—

System performance: When the procedure is run with 20 μ L of the standard solution under the above operating con-

ditions, fumaric acid, bisoprolol and the internal standard are eluted in this order with the resolution between the peaks of bisoprolol and the internal standard being not less than 12.

System repeatability: When the test is repeated 6 times with 20 μ L of the standard solution under the above operating conditions, the relative standard deviation of the ratio of the peak area of bisoprolol to that of the internal standard is not more than 1.0%.

Containers and storage Containers—Tight containers.

Bleomycin Hydrochloride

ブレオマイシン塩酸塩

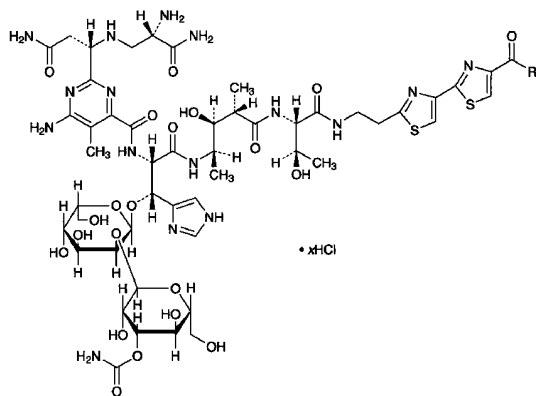

Bleomycinoic Acid hydrochloride	: R = OH
Bleomycin A ₁ hydrochloride	: R =
Bleomycin Demethyl-A ₂ hydrochloride	: R =
Bleomycin A ₂ hydrochloride	: R = + X ⁻
Bleomycin A _{2'-a} hydrochloride	: R =
Bleomycin A _{2'-b} hydrochloride	: R =
Bleomycin A ₅ hydrochloride	: R =
Bleomycin B ₁ hydrochloride	: R = NH ₂
Bleomycin B ₂ hydrochloride	: R =
Bleomycin B ₄ hydrochloride	: R =

Bleomycinoic Acid hydrochloride
1-Bleomycinoic acid hydrochloride

Bleomycin A₁ hydrochloride
N¹-[3-(Methylsulfinyl)propyl]bleomycinamide hydrochloride

Bleomycin Demethyl-A₂ hydrochloride
N¹-[3-(Methylsulfonyl)propyl]bleomycinamide hydrochloride

Bleomycin A₂ hydrochloride
N¹-[3-(Dimethylsulfonio)propyl]bleomycinamide hydrochloride

Bleomycin A_{2'-a} hydrochloride
N¹-(4-Aminobutyl)bleomycinamide hydrochloride

Bleomycin A_{2'-b} hydrochloride
N¹-(3-Aminopropyl)bleomycinamide hydrochloride

Bleomycin A₅ hydrochloride
N¹-[3-[(4-Aminobutyl)amino]propyl]bleomycinamide hydrochloride

Bleomycin B₁ hydrochloride
Bleomycinamide hydrochloride

Bleomycin B₂ hydrochloride
N¹-(4-Guanidinobutyl)bleomycinamide hydrochloride

Bleomycin B₄ hydrochloride
N¹-[4-[3-(4-Guanidinobutyl)guanidino]butyl]-bleomycinamide hydrochloride
[11056-06-7, Bleomycin]

Bleomycin Hydrochloride is the hydrochloride of a mixture of substances having antitumor activity produced by the growth of *Streptomyces verticillus*.

It contains not less than 1400 μ g (potency) and not more than 2000 μ g (potency) per mg, calculated on the dried basis. The potency of Bleomycin Hydrochloride is expressed as mass (potency) of bleomycin A₂ (C₅₅H₈₄ClN₁₇O₂₁S₃; 1451.00).

Description Bleomycin Hydrochloride occurs as a white to yellow-white powder.

It is freely soluble in water, and slightly soluble in ethanol (95).

It is hygroscopic.

Identification (1) To 4 mg of Bleomycin Hydrochloride add 5 μ L of copper (II) sulfate TS, and dissolve in water to make 100 mL. Determine the absorption spectrum of this solution as directed under Ultraviolet-visible Spectrophotometry <2.24>, and compare the spectrum with the Reference Spectrum: both spectra exhibit similar intensities of absorption at the same wavelengths.

(2) Determine the infrared absorption spectrum of Bleomycin Hydrochloride as directed in the potassium bromide disk method under Infrared Spectrophotometry <2.25>, and compare the spectrum with the Reference Spectrum: both spectra exhibit similar intensities of absorption at the same wave numbers.

(3) A solution of Bleomycin Hydrochloride (1 in 100) responds to Qualitative Tests <1.09> (2) for chloride.

pH <2.54> The pH of a solution obtained by dissolving 0.10 g of Bleomycin Hydrochloride in 20 mL of water is between 4.5 and 6.0.

Content ratio of the active principle Dissolve 10 mg of Bleomycin Hydrochloride in 20 mL of water, and use this solution as the sample solution. Perform the test with 20 μ L of the sample solution as directed under Liquid Chromatography <2.01> according to the following conditions, and determine each peak area by the automatic integration method, and calculate their amounts by the area percentage method: the amount of the peak of bleomycin A₂ (the first principal peak) is between 55% and 70%, that of bleomycin B₂ (the second principal peak) is between 25% and 32%, the total amount of the peak of bleomycin A₂ and bleomycin B₂ is not less than 85%, the amount of the peak of demethylbleomycin A₂ (a peak having the relative retention time of 1.5 – 2.5 to bleomycin A₂) is not more than 5.5%, and the total amount of the rest peaks is not more than 9.5%.

Operating conditions—

Detector: An ultraviolet absorption photometer (wavelength: 254 nm).

Column: A stainless steel column 4.6 mm in inside diameter and 25 cm in length, packed with octadecylsilanized silica gel for liquid chromatography (7 μ m in particle diameter).

Column temperature: A constant temperature of about 40°C.

Mobile phase stock solution: Dissolve 0.96 g of sodium 1-pentanesulfonate and 1.86 g of disodium dihydrogen ethylenediamine tetraacetate dihydrate in 1000 mL of water and 5 mL of acetic acid (100), and adjust the pH to 4.3 with ammonia TS.

Mobile phase A: A mixture of the mobile phase stock solution and methanol (9:1).

Mobile phase B: A mixture of the mobile phase stock solution and methanol (3:2).

Flowing of mobile phase: Control the gradient by mixing the mobile phases A and B as directed in the following table.

Time after injection of sample (min)	Mobile phase A (vol%)	Mobile phase B (vol%)
0 – 60	100 → 0	0 → 100
60 – 75	0	100

Flow rate: About 1.2 mL per minute.

Time span of measurement: 20 minutes after elution of the peak of demethylbleomycin A₂, beginning after the solvent peak.

System suitability—

System performance: When the procedure is run with 20 μL of the sample solution under the above operating conditions, bleomycin A₂ and bleomycin B₂ are eluted in this order with the resolution between these peaks being not less than 5.

System repeatability: When the test is repeated 6 times with 20 μL of the sample solution under the above operating conditions, the relative standard deviation of the peak area of bleomycin A₂ is not more than 2.0%.

Purity (1) Clarity and color of solution—A solution obtained by dissolving 80 mg of Bleomycin Hydrochloride in 4 mL of water is clear and colorless.

(2) Copper—Dissolve exactly 75 mg of Bleomycin Hydrochloride in exactly 10 mL of diluted nitric acid (1 in 100), and use this solution as the sample solution. Separately, to exactly 15 mL of Standard Copper Solution add diluted nitric acid (1 in 100) to make exactly 100 mL, and use this solution as the standard solution. Perform the test with the sample solution and standard solution as directed under Atomic Absorption Spectrophotometry <2.23> according to the following conditions: the absorbance of the sample solution is not more than that of the standard solution (not more than 200 ppm).

Gas: Combustible gas—Acetylene.

Supporting gas—Air.

Lamp: Copper hollow-cathode lamp.

Wavelength: 324.8 nm.

Loss on drying <2.41> Not more than 5.0% (60 mg, in vacuum, phosphorus (V) oxide, 60°C, 3 hours. Take the sample to be tested while avoiding moisture absorption).

Assay Perform the test according to the Cylinder-plate method as directed under Microbial Assay for Antibiotics <4.02> according to the following conditions.

(i) Test organism—*Mycobacterium smegmatis* ATCC 607

(ii) Agar medium for seed, base layer and transferring the test organism

Glycerin	10.0 g
Peptone	10.0 g
Meat extract	10.0 g
Sodium chloride	3.0 g
Agar	15.0 g
Water	1000 mL

Mix all the components, and sterilize. Adjust the pH after sterilization to 6.9 – 7.1 with sodium hydroxide TS.

(iii) Liquid media for suspending the test organism

Glycerin	10.0 g
Peptone	10.0 g
Meat extract	10.0 g
Sodium chloride	3.0 g
Water	1000 mL

Mix all the components, and sterilize. Adjust the pH after sterilization to 6.9 – 7.1 with sodium hydroxide TS.

(iv) Preparation of seeded agar layer—Cultivate the test organism on the slant of the agar medium for transferring the test organism at 27°C for 40 to 48 hours, then inoculate the test organism thus obtained in 100 mL of the liquid media for suspending the test organism, cultivate with shaking at between 25°C and 27°C for 5 days, and use this as the suspension of test organism. Store the suspension of test organism at a temperature not exceeding 5°C, and use within 14 days. Add 0.5 mL of the suspension of test organism in 100 mL of the agar medium for seed previously kept at 48°C, mix thoroughly, and use as the seeded agar layer.

(v) Preparation of cylinder-agar plate—Proceed as directed in 1.7. Preparation of cylinder-agar plates under the Microbial Assay for Antibiotics, dispensing 5.0 mL of agar medium for base layer and 8.0 mL of the agar medium for seed into the Petri dish.

(vi) Standard solutions—Weigh accurately an amount of Bleomycin A₂ Hydrochloride RS, previously dried under reduced pressure not exceeding 0.67 kPa at an ordinary temperature for 3 hours, equivalent to about 15 mg (potency), dissolve in 0.1 mol/L phosphate buffer solution (pH 6.8) to make exactly 100 mL, and use this solution as the standard stock solution. Keep the standard stock solution at 5°C or below, and use within 30 days. Take exactly a suitable amount of the standard stock solution before use, add 0.1 mol/L phosphate buffer solution (pH 6.8) to make solutions so that each mL contains 30 μg (potency) and 15 μg (potency), and use these solutions as the high concentration standard solution and low concentration standard solution, respectively.

(vii) Sample solutions—Weigh accurately an amount of Bleomycin Hydrochloride, equivalent to about 15 mg (potency), and dissolve in 0.1 mol/L phosphate buffer solution (pH 6.8) to make exactly 100 mL. Take exactly a suitable amount of this solution, add 0.1 mol/L phosphate buffer solution (pH 6.8) to make solutions so that each mL contains 30 μg (potency) and 15 μg (potency), and use these solutions as the high concentration sample solution and low concentration sample solution, respectively.

Containers and storage Containers—Tight containers.

Bleomycin Sulfate

ブレオマイシン硫酸塩

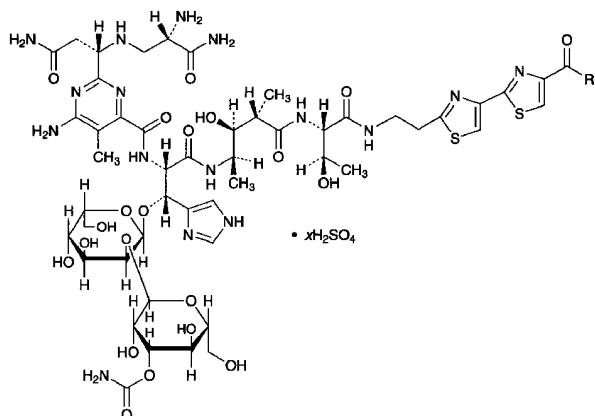

Bleomycinoic Acid sulfate	: R = OH
Bleomycin A ₁ sulfate	: R =
Bleomycin Demethyl-A ₂ sulfate	: R =
Bleomycin A ₂ sulfate	: R =
Bleomycin A _{2'-a} sulfate	: R =
Bleomycin A _{2'-b} sulfate	: R =
Bleomycin A ₅ sulfate	: R =
Bleomycin B ₁ ' sulfate	: R = NH ₂
Bleomycin B ₂ sulfate	: R =
Bleomycin B ₄ sulfate	: R =

Bleomycinoic Acid sulfate
1-Bleomycinoic acid sulfate

Bleomycin A₁ sulfate
N¹-[3-(Methylsulfanyl)propyl]bleomycinamide sulfate

Bleomycin Demethyl-A₂ sulfate
N¹-[3-(Methylsulfanyl)propyl]bleomycinamide sulfate

Bleomycin A₂ sulfate
N¹-[3-(Dimethylsulfonium)propyl]bleomycinamide sulfate

Bleomycin A_{2'-a} sulfate
N¹-(4-Aminobutyl)bleomycinamide sulfate

Bleomycin A_{2'-b} sulfate
N¹-(3-Aminopropyl)bleomycinamide sulfate

Bleomycin A₅ sulfate
N¹-{3-[(4-Aminobutyl)amino]propyl}bleomycinamide sulfate

Bleomycin B₁' sulfate
Bleomycinamide sulfate

Bleomycin B₂ sulfate
N¹-(4-Guanidinobutyl)bleomycinamide sulfate

Bleomycin B₄ sulfate
N¹-{4-[3-(4-Guanidinobutyl)guanidino]butyl}-bleomycinamide sulfate
[9041-93-4, Bleomycin Sulfate]

Bleomycin Sulfate is the sulfate of a mixture of substances having antitumor activity produced by the

growth of *Streptomyces verticillus*.

It contains not less than 1400 μg (potency) and not more than 2000 μg (potency) per mg, calculated on the dried basis. The potency of Bleomycin Sulfate is expressed as mass (potency) of bleomycin A₂ (C₅₅H₈₄ClN₁₇O₂₁S₃: 1451.00).

Description Bleomycin Sulfate occurs as a white to yellow-white powder.

It is freely soluble in water, and slightly soluble in ethanol (95).

It is hygroscopic.

Identification (1) To 4 mg of Bleomycin Sulfate add 5 μL of copper (II) sulfate TS, and dissolve in water to make 100 mL. Determine the absorption spectrum of this solution as directed under Ultraviolet-visible Spectrophotometry <2.24>, and compare the spectrum with the Reference Spectrum: both spectra exhibit similar intensities of absorption at the same wavelengths.

(2) Determine the infrared absorption spectrum of Bleomycin Sulfate as directed in the potassium bromide disk method under Infrared Spectrophotometry <2.25>, and compare the spectrum with the Reference Spectrum: both spectra exhibit similar intensities of absorption at the same wave numbers.

(3) A solution of Bleomycin Sulfate (1 in 200) responds to Qualitative Tests <1.09> (1) and (2) for sulfate.

pH <2.54> The pH of a solution obtained by dissolving 10 mg of Bleomycin Sulfate in 20 mL of water is between 4.5 and 6.0.

Content ratio of the active principle Dissolve 10 mg of Bleomycin Sulfate in 20 mL of water, and use this solution as the sample solution. Perform the test with 20 μL of the sample solution as directed under Liquid Chromatography <2.01> according to the following conditions, and determine each peak area by the automatic integration method, and calculate their amounts by the area percentage method: the amount of the peak of bleomycin A₂ (the first principal peak) is between 55% and 70%, that of bleomycin B₂ (the second principal peak) is between 25% and 32%, the total amount of the peak of bleomycin A₂ and bleomycin B₂ is not less than 85%, the amount of the peak of demethylbleomycin A₂ (a peak having the relative retention time of 1.5 – 2.5 to bleomycin A₂) is not more than 5.5%, and the total amount of the rest peaks is not more than 9.5%.

Operating conditions—

Detector: An ultraviolet absorption photometer (wavelength: 254 nm).

Column: A stainless steel column 4.6 mm in inside diameter and 25 cm in length, packed with octadecylsilanized silica gel for liquid chromatography (7 μm in particle diameter).

Column temperature: A constant temperature of about 40°C.

Mobile phase stock solution: Dissolve 0.96 g of sodium 1-pentanesulfonate and 1.86 g of disodium dihydrogen ethylenediamine tetraacetate dihydrate in 1000 mL of water and 5 mL of acetic acid (100), and adjust the pH to 4.3 with ammonia TS.

Mobile phase A: A mixture of the mobile phase stock solution and methanol (9:1).

Mobile phase B: A mixture of the mobile phase stock solution and methanol (3:2).

Flowing of mobile phase: Control the gradient by mixing the mobile phases A and B as directed in the following table.

Time after injection of sample (min)	Mobile phase A (vol%)	Mobile phase B (vol%)
0 - 60	100 → 0	0 → 100
60 - 75	0	100

Flow rate: About 1.2 mL per minute.

Time span of measurement: Twenty minutes after elution of the peak of demethylbleomycin A₂, beginning after the solvent peak.

System suitability—

System performance: When the procedure is run with 20 μ L of the sample solution under the above operating conditions, bleomycin A₂ and bleomycin B₂ are eluted in this order with the resolution between these peaks being not less than 5.

System repeatability: When the test is repeated 6 times with 20 μ L of the sample solution under the above operating conditions, the relative standard deviation of the peak area of bleomycin A₂ is not more than 2.0%.

Purity (1) Clarity and color of solution—A solution obtained by dissolving 80 mg of Bleomycin Sulfate in 4 mL of water is clear and colorless.

(2) Copper—Dissolve exactly 75 mg of Bleomycin Sulfate in 10 mL of diluted nitric acid (1 in 100), and use this solution as the sample solution. Separately, to exactly 15 mL of Standard Copper Solution add diluted nitric acid (1 in 100) to make exactly 100 mL, and use this solution as the standard solution. Perform the test with the sample solution and standard solution as directed under Atomic Absorption Spectrophotometry <2.23> according to the following conditions: the absorbance of the sample solution is not more than that of the standard solution (not more than 200 ppm).

Gas: Combustible gas—Acetylene.

Supporting gas—Air.

Lamp: Copper hollow-cathode lamp.

Wavelength: 324.8 nm.

Loss on drying <2.41> Not more than 3.0% (60 mg, in vacuum, phosphorus (V) oxide, 60°C, 3 hours. Take the sample to be tested while avoiding moisture absorption).

Assay Perform the test according to the Cylinder-plate method as directed under Microbial Assay for Antibiotics <4.02> according to the following conditions.

(i) Test organism—*Mycrobacterium smegmatis* ATCC 607

(ii) Agar medium for seed, base layer and transferring the test organism

Glycerin	10.0 g
Peptone	10.0 g
Meat extract	10.0 g
Sodium chloride	3.0 g
Agar	15.0 g
Water	1000 mL

Mix all the components and sterilize. Adjust the pH after sterilization to 6.9 - 7.1 with sodium hydroxide TS.

(iii) Liquid media for suspending the test organism

Glycerin	10.0 g
Peptone	10.0 g
Meat extract	10.0 g
Sodium chloride	3.0 g
Water	1000 mL

Mix all the components and sterilize. Adjust the pH after sterilization to 6.9 - 7.1 with sodium hydroxide TS.

(iv) Preparation of seeded agar layer—Cultivate the test organism on the slant of the agar medium for transferring

the test organism at 27°C for 40 to 48 hours, then inoculate the test organism thus obtained in 100 mL of the liquid media for suspending the test organism, cultivate with shaking at between 25°C and 27°C for 5 days, and use this as the suspension of test organism. Store the suspension of test organism at a temperature not exceeding 5°C, and use within 14 days. Add 0.5 mL of the suspension of test organism in 100 mL of the agar medium for seed previously kept at 48°C, mix thoroughly, and use as the seeded agar layer.

(v) Preparation of cylinder-agar plate—Proceed as directed in 1.7. Preparation of cylinder-agar plates under the Microbial Assay for Antibiotics, dispensing 5.0 mL of agar medium for base layer and 8.0 mL of the agar medium for seed into the Petri dish.

(vi) Standard solutions—Weigh accurately an amount of Bleomycin A₂ Hydrochloride RS, previously dried under reduced pressure not exceeding 0.67 kPa at an ordinary temperature for 3 hours, equivalent to about 15 mg (potency), dissolve in 0.1 mol/L phosphate buffer solution (pH 6.8) to make exactly 100 mL, and use this solution as the standard stock solution. Keep the standard stock solution at 5°C or below, and use within 30 days. Take exactly a suitable amount of the standard stock solution before use, add 0.1 mol/L phosphate buffer solution (pH 6.8) to make solutions so that each mL contains 30 μ g (potency) and 15 μ g (potency), and use these solutions as the high concentration standard solution and low concentration standard solution, respectively.

(vii) Sample solutions—Weigh accurately an amount of Bleomycin Sulfate, equivalent to about 15 mg (potency), dissolve in 0.1 mol/L phosphate buffer solution (pH 6.8) to make exactly 100 mL. Take exactly a suitable amount of this solution, add 0.1 mol/L phosphate buffer solution (pH 6.8) to make solutions so that each mL contains 30 μ g (potency) and 15 μ g (potency), and use these solutions as the high concentration sample solution and low concentration sample solution, respectively.

Containers and storage Containers—Tight containers.

Boric Acid

ホウ酸

H₃BO₃: 61.83

Boric Acid, when dried, contains not less than 99.5% of boric acid (H₃BO₃).

Description Boric Acid occurs as colorless or white, crystals or crystalline powder. It is odorless, and has a slight, characteristic taste.

It is freely soluble in warm water, in hot ethanol (95) and in glycerin, soluble in water and in ethanol (95), and practically insoluble in diethyl ether.

The pH of a solution of 1.0 g of Boric Acid in 20 mL of water is between 3.5 and 4.1.

Identification A solution of Boric Acid (1 in 20) responds to Qualitative Tests <1.09> for borate.

Purity (1) Clarity and color of solution—Dissolve 1.0 g of Boric Acid in 25 mL of water or in 10 mL of hot ethanol (95): the solution is clear and colorless.

(2) Heavy metals <1.07>—Proceed with 2.0 g of Boric Acid according to Method 1, and perform the test. Prepare the control solution with 2.0 mL of Standard Lead Solution

(not more than 10 ppm).

(3) Arsenic <1.11>—Prepare the test solution with 0.40 g of Boric Acid according to Method 1, and perform the test (not more than 5 ppm).

Loss on drying <2.41> Not more than 0.5% (2 g, silica gel, 5 hours).

Assay Weigh accurately about 1.5 g of Boric Acid, previously dried, add 15 g of D-sorbitol and 50 mL of water, and dissolve by warming. After cooling, titrate <2.50> with 1 mol/L sodium hydroxide VS (indicator: 2 drops of phenolphthalein TS).

Each mL of 1 mol/L sodium hydroxide VS
= 61.83 mg of H₃BO₃

Containers and storage Containers—Well-closed containers.

Freeze-dried Botulism Antitoxin, Equine

乾燥ボツリヌスウマ抗毒素

Freeze-dried Botulism Antitoxin, Equine, is a preparation for injection which is dissolved before use.

It contains botulism antitoxin type A, botulism antitoxin type B, botulism antitoxin type E and botulism antitoxin type F in immunoglobulin of horse origin. It may contain one, two or three of these four antitoxins.

It conforms to the requirements of Freeze-dried Botulism Antitoxin, Equine, in the Minimum Requirements for Biological Products.

Description Freeze-dried Botulism Antitoxin, Equine, becomes a colorless or yellow-brown, clear liquid or a slightly white-turbid liquid on the addition of solvent.

Bromazepam

ブロマゼパム

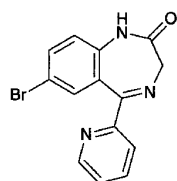

C₁₄H₁₀BrN₃O: 316.15

7-Bromo-5-(pyridin-2-yl)-1,3-dihydro-2H-1,4-benzodiazepin-2-one
[1812-30-2]

Bromazepam, when dried, contains not less than 99.0% and not more than 101.0% of bromazepam (C₁₄H₁₀BrN₃O).

Description Bromazepam occurs as white to light yellow-white, crystals or crystalline powder.

It is freely soluble in acetic acid (100), slightly soluble in methanol, in ethanol (99.5) and in acetone, and practically insoluble in water.

Melting point: about 245°C (with decomposition).

Identification (1) Determine the absorption spectrum of a solution of Bromazepam in ethanol (99.5) (1 in 200,000) as

directed under Ultraviolet-visible Spectrophotometry <2.24>, and compare the spectrum with the Reference Spectrum: both spectra exhibit similar intensities of absorption at the same wavelengths.

(2) Determine the infrared absorption spectrum of Bromazepam, previously dried, as directed in the potassium bromide disk method under Infrared Spectrophotometry <2.25>, and compare the spectrum with the Reference Spectrum: both spectra exhibit similar intensities of absorption at the same wave numbers.

Purity (1) Heavy metals <1.07>—Proceed with 1.0 g of Bromazepam in a platinum crucible according to Method 4, and perform the test. Prepare the control solution with 2.0 mL of Standard Lead Solution (not more than 20 ppm).

(2) Related substances—Dissolve 50 mg of Bromazepam in 5 mL of a mixture of acetone and methanol (3:2), and use this solution as the sample solution. Pipet 1 mL of the sample solution, and add the mixture of acetone and methanol (3:2) to make exactly 50 mL. Pipet 5 mL of this solution, add the mixture of acetone and methanol (3:2) to make exactly 50 mL, and use this solution as the standard solution. Perform the test with these solutions as directed under Thin-layer Chromatography <2.03>. Spot 20 μL each of the sample solution and standard solution on a plate of silica gel with fluorescent indicator for thin-layer chromatography. Develop the plate with a mixture of ethyl acetate, ammonia solution (28) and ethanol (99.5) (38:1:1) to a distance of about 12 cm, and air-dry the plate. Examine under ultraviolet light (main wavelength: 254 nm): the spots other than the principal spot obtained from the sample solution and the spot of the starting point are not more than 2, and not more intense than the spot from the standard solution.

Loss on drying <2.41> Not more than 0.20% (1 g, 105°C, 4 hours).

Residue on ignition <2.44> Not more than 0.1% (1 g).

Assay Weigh accurately about 0.4 g of Bromazepam, previously dried, dissolve in 80 mL of acetic acid (100), and titrate <2.50> with 0.1 mol/L perchloric acid VS (potentiometric titration). Perform a blank determination in the same manner, and make any necessary correction.

Each mL of 0.1 mol/L perchloric acid VS
= 31.62 mg of C₁₄H₁₀BrN₃O

Containers and storage Containers—Well-closed containers.

Bromfenac Sodium Hydrate

ブロムフェナクナトリウム水和物

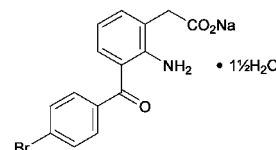

C₁₅H₁₁BrNNaO₃·1½H₂O: 383.17

Sodium 2-[2-amino-3-(4-bromobenzoyl)phenyl]acetate sesquihydrate
[120638-55-3]

Bromfenac Sodium Hydrate contains not less than 97.5% and not more than 101.5% of bromfenac sodium (C₁₅H₁₁BrNNaO₃; 356.15), calculated on the anhydrous basis.

Description Bromfenac Sodium Hydrate occurs as a yellow to orange crystalline powder.

It is freely soluble in water, soluble in methanol, and slightly soluble in ethanol (99.5).

It dissolves in a solution of sodium hydrogen carbonate (21 in 2500).

Identification (1) Dissolve 10 mg of Bromfenac Sodium Hydrate in 500 mL of a solution of sodium hydrogen carbonate (21 in 2500). Determine the absorption spectrum of this solution as directed under Ultraviolet-visible Spectrophotometry <2.24>, and compare the spectrum with the Reference Spectrum or the spectrum of a solution of Bromfenac Sodium RS prepared in the same manner as the sample solution: both spectra exhibit similar intensities of absorption at the same wavelengths.

(2) Determine the infrared absorption spectrum of Bromfenac Sodium Hydrate as directed in the potassium bromide disk method under Infrared Spectrophotometry <2.25>, and compare the spectrum with the Reference Spectrum or the spectrum of Bromfenac Sodium RS: both spectra exhibit similar intensities of absorption at the same wave numbers.

(3) A solution of Bromfenac Sodium Hydrate (1 in 20) responds to Qualitative Tests <1.09> (1) for sodium salt.

pH <2.54> Dissolve 1.0 g of Bromfenac Sodium Hydrate in 20 mL of water: the pH of the solution is between 8.4 and 10.2.

Purity (1) Heavy metals <1.07>—Proceed with 1.0 g of Bromfenac Sodium Hydrate according to Method 2, and perform the test. Prepare the control solution with 2.0 mL of Standard Lead Solution (not more than 20 ppm).

(2) Related substances—Dissolve 50 mg of Bromfenac Sodium Hydrate in 100 mL of methanol, and use this solution as the sample solution. Pipet 1 mL of the sample solution, add methanol to make exactly 100 mL, and use this solution as the standard solution. Perform the test with exactly 20 μ L each of the sample solution and standard solution as directed under Liquid Chromatography <2.01> according to the following conditions, and determine each peak area by the automatic integration method: the area of the peak other than bromfenac obtained from the sample solution is not larger than 1/10 times the peak area of bromfenac from the standard solution, and the total area of the peaks other than bromfenac from the sample solution is not larger than the peak area of bromfenac from the standard solution.

Operating conditions—

Detector, column and column temperature: Proceed as directed in the operating conditions in the Assay.

Mobile phase: Dissolve 3.85 g of ammonium acetate in 1000 mL of water, and adjust to pH 4.0 with acetic acid (100). To 570 mL of this solution add 430 mL of acetonitrile.

Flow rate: Adjust so that the retention time of bromfenac is about 8 minutes.

Time span of measurement: About 3 times as long as the retention time of bromfenac, beginning after the solvent peak.

System suitability—

Test for required detectability: Pipet 2 mL of the standard solution, and add methanol to make exactly 20 mL. Confirm that the peak area of bromfenac obtained with 20 μ L of this solution is equivalent to 7 to 13% of that with 20 μ L of the standard solution.

System performance: When the procedure is run with 20 μ L of the standard solution under the above operating con-

ditions, the number of theoretical plates and the symmetry factor of the peak of bromfenac are not less than 5000 and not more than 1.5, respectively.

System repeatability: When the test is repeated 6 times with 20 μ L of the standard solution under the above operating conditions, the relative standard deviation of the peak area of bromfenac is not more than 2.0%.

Water <2.48> 6.9–8.5% (0.15 g, volumetric titration, direct titration. Use a solution of imidazole for water determination in methanol for water determination (1 in 80) instead of methanol for water determination).

Assay Weigh accurately about 30 mg each of Bromfenac Sodium Hydrate and Bromfenac Sodium RS (separately determine the water <2.48> in the same manner as Bromfenac Sodium Hydrate), dissolve each in methanol to make exactly 50 mL. Pipet 5 mL each of these solutions, add the mobile phase to make them exactly 100 mL, and use these solutions as the sample solution and the standard solution, respectively. Perform the test with exactly 20 μ L each of the sample solution and standard solution as directed under Liquid Chromatography <2.01> according to the following conditions, and determine the peak areas, A_T and A_S , of bromfenac in each solution.

$$\begin{aligned} \text{Amount (mg) of bromfenac sodium (C}_{15}\text{H}_{11}\text{BrNNaO}_3) \\ = M_S \times A_T/A_S \end{aligned}$$

M_S : Amount (mg) of Bromfenac Sodium RS taken, calculated on the anhydrous basis

Operating conditions—

Detector: An ultraviolet absorption photometer (wavelength: 266 nm).

Column: A stainless steel column 4.6 mm in inside diameter and 15 cm in length, packed with octadecylsilanized silica gel for liquid chromatography (5 μ m in particle diameter).

Column temperature: A constant temperature of about 35°C.

Mobile phase: Dissolve 3.85 g of ammonium acetate in 1000 mL of water. To 600 mL of this solution add 250 mL of methanol and 150 mL of tetrahydrofuran.

Flow rate: Adjust so that the retention time of bromfenac is about 9 minutes.

System suitability—

System performance: When the procedure is run with 20 μ L of the standard solution under the above operating conditions, the number of theoretical plates and the symmetry factor of the peak of bromfenac are not less than 5000 and not more than 1.5, respectively.

System repeatability: When the test is repeated 6 times with 20 μ L of the standard solution under the above operating conditions, the relative standard deviation of the peak area of bromfenac is not more than 1.0%.

Containers and storage Containers—Tight containers.

Storage—Light-resistant.

Bromfenac Sodium Ophthalmic Solution

ブロムフェナクナトリウム点眼液

Bromfenac Sodium Ophthalmic Solution is an aqueous ophthalmic preparation.

It contains not less than 90.0% and not more than 110.0% of the labeled amount of Bromfenac Sodium Hydrate ($C_{15}H_{11}BrNNaO_3 \cdot 1\frac{1}{2}H_2O$: 383.17).

Method of preparation Prepare as directed under Ophthalmic Liquids and Solutions, with Bromfenac Sodium Hydrate.

Description Bromfenac Sodium Ophthalmic Solution occurs as a clear and yellow liquid.

Identification To a volume of Bromfenac Sodium Ophthalmic Solution, equivalent to 1 mg of Bromfenac Sodium Hydrate, add a solution of sodium hydrogen carbonate (21 in 2500) to make 50 mL, and determine the absorption spectrum of this solution as directed under Ultraviolet-visible Spectrophotometry <2.24>: it exhibits maxima between 266 nm and 270 nm, and between 377 nm and 381 nm.

pH Being specified separately when the drug is granted approval based on the Law.

Purity Related substances—Being specified separately when the drug is granted approval based on the Law.

Foreign insoluble matter <6.11> It meets the requirement.

Insoluble particulate matter <6.08> It meets the requirement.

Sterility <4.06> Perform the test according to the Membrane filtration method: it meets the requirement.

Assay Pipet a volume of Bromfenac Sodium Ophthalmic Solution, equivalent to about 2 mg of bromfenac sodium hydrate ($C_{15}H_{11}BrNNaO_3 \cdot 1\frac{1}{2}H_2O$), add the mobile phase to make exactly 20 mL, and use this solution as the sample solution. Separately, weigh accurately about 20 mg of Bromfenac Sodium RS (separately determine the water <2.48> in the same manner as Bromfenac Sodium Hydrate), and dissolve in the mobile phase to make exactly 20 mL. Pipet 2 mL of this solution, add the mobile phase to make exactly 20 mL, and use this solution as the standard solution. Perform the test with exactly 10 μ L each of the sample solution and standard solution as directed under Liquid Chromatography <2.01> according to the following conditions, and determine the peak areas, A_T and A_S , of bromfenac in each solution.

$$\begin{aligned} & \text{Amount (mg) of bromfenac sodium hydrate} \\ & (C_{15}H_{11}BrNNaO_3 \cdot 1\frac{1}{2}H_2O) \\ & = M_S \times A_T / A_S \times 1/10 \times 1.076 \end{aligned}$$

M_S : Amount (mg) of Bromfenac Sodium RS taken, calculated on the anhydrous basis

Operating conditions—

Detector: An ultraviolet absorption photometer (wavelength: 266 nm).

Column: A stainless steel column 4.6 mm in inside diameter and 25 cm in length, packed with octadecylsilanized silica gel for liquid chromatography (5 μ m in particle diameter).

Column temperature: A constant temperature of about 40°C.

Mobile phase: Dissolve 1.98 g of diammonium hydrogen

phosphate in 750 mL of water, adjust to pH 7.3 with phosphoric acid, and add 250 mL of acetonitrile.

Flow rate: Adjust so that the retention time of bromfenac is about 18 minutes.

System suitability—

System performance: When the procedure is run with 10 μ L of the standard solution under the above operating conditions, the number of theoretical plates and the symmetry factor of the peak of bromfenac are not less than 13,000 and not more than 2.0, respectively.

System repeatability: When the test is repeated 6 times with 10 μ L of the standard solution under the above operating conditions, the relative standard deviation of the peak area of bromfenac is not more than 1.0%.

Containers and storage Containers—Tight containers.

Bromhexine Hydrochloride

ブロムヘキシン塩酸塩

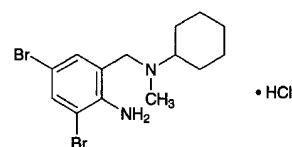

$C_{14}H_{20}Br_2N_2 \cdot HCl$: 412.59

2-Amino-3,5-dibromo-*N*-cyclohexyl-*N*-methylbenzylamine monohydrochloride [611-75-6]

Bromhexine Hydrochloride, when dried, contains not less than 98.5% of bromhexine hydrochloride ($C_{14}H_{20}Br_2N_2 \cdot HCl$).

Description Bromhexine Hydrochloride occurs as white, crystals or crystalline powder.

It is freely soluble in formic acid, sparingly soluble in methanol, and slightly soluble in water and in ethanol (95).

The pH of its saturated solution is between 3.0 and 5.0.

Melting point: about 239°C (with decomposition).

Identification (1) Dissolve 3 mg of Bromhexine Hydrochloride in 0.01 mol/L hydrochloric acid TS to make 100 mL. Determine the absorption spectrum of the solution as directed under Ultraviolet-visible Spectrophotometry <2.24>, and compare the spectrum with the Reference Spectrum: both spectra exhibit similar intensities of absorption at the same wavelengths.

(2) Determine the infrared absorption spectrum of Bromhexine Hydrochloride, previously dried, as directed in the potassium bromide disk method under Spectrophotometry <2.25>, and compare the spectrum with the Reference Spectrum: both spectra exhibit similar intensities of absorption at the same wave numbers.

(3) Add 20 mL of water to 1 g of Bromhexine Hydrochloride. After thorough shaking, add 3 mL of sodium hydroxide TS, and extract with four 20-mL portions of diethyl ether. Neutralize the water layer with dilute nitric acid: the solution responds to Qualitative Tests <1.09> (2) for chloride.

Purity (1) Heavy metals <1.07>—Proceed with 2.0 g of Bromhexine Hydrochloride according to Method 2, and perform the test. Prepare the control solution with 2.0 mL of Standard Lead Solution (not more than 10 ppm).

(2) Related substances—Conduct this procedure without exposure to light, using light-resistant vessels. Dissolve 50

mg of Bromhexine Hydrochloride in 10 mL of methanol, and use this solution as the sample solution. Pipet 1 mL of the sample solution, and add the mobile phase to make exactly 20 mL. Pipet 1 mL of this solution, add the mobile phase to make exactly 25 mL, and use this solution as the standard solution. Perform the test with exactly 5 μ L each of the sample solution and standard solution as directed under Liquid Chromatography <2.01> according to the following conditions, and determine each peak area by the automatic integration method: each peak area other than bromhexine obtained from the sample solution is not larger than the peak area of bromhexine from the standard solution.

Operating conditions—

Detector: An ultraviolet absorption photometer (wavelength: 245 nm).

Column: A stainless steel column about 5 mm in inside diameter and about 15 cm in length, packed with octadecylsilanized silica gel for liquid chromatography (5 μ m in particle diameter).

Column temperature: A constant temperature of about 40°C.

Mobile phase: Dissolve 1.0 g of potassium dihydrogen phosphate in 900 mL of water, adjust the pH to 7.0 with 0.5 mol/L sodium hydroxide TS, and add water to make 1000 mL. To 200 mL of this solution add 800 mL of acetonitrile.

Flow rate: Adjust so that the retention time of bromhexine is about 6 minutes.

Selection of column: To 0.05 g of bamethan sulfate add 0.5 mL of the sample solution, and add the mobile phase to make 10 mL. Proceed with 5 μ L of this solution under the above operating conditions, and calculate the resolution. Use a column giving elution of bamethan and bromhexine in this order with the resolution between these peaks being not less than 7.

Detection sensitivity: Adjust the detection sensitivity so that the peak height of bromhexine from 5 μ L of the standard solution is between 5 mm and 15 mm.

Time span of measurement: About 2 times as long as the retention time of bromhexine, beginning after the solvent peak.

Loss on drying <2.41> Not more than 0.5% (1 g, 105°C, 4 hours).

Residue on ignition <2.44> Not more than 0.1% (1 g).

Assay Weigh accurately about 0.5 g of Bromhexine Hydrochloride, previously dried, dissolve in 2 mL of formic acid, add 60 mL of acetic anhydride, and warm in a water bath at 50°C for 15 minutes. After cooling, titrate <2.50> with 0.1 mol/L perchloric acid VS until the color of the solution changes from purple through blue-green to yellow-green (indicator: 2 drops of crystal violet TS). Perform a blank determination in the same manner, and make any necessary correction.

Each mL of 0.1 mol/L perchloric acid VS
= 41.26 mg of C₁₄H₂₀BrN₂.HCl

Containers and storage Containers—Well-closed containers.

Storage—Light-resistant.

Bromocriptine Mesilate

ブロモクリプチンメシル酸塩

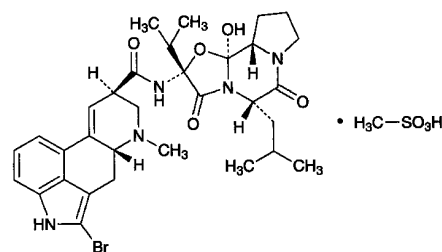

C₃₂H₄₀BrN₅O₅·CH₄O₃S: 750.70
(5'S)-2-Bromo-12'-hydroxy-2'-(1-methylethyl)-5'-(2-methylpropyl)ergotaman-3',6',18-trione monomethanesulfonate
[22260-51-1]

Bromocriptine Mesilate contains not less than 98.0% of bromocriptine mesilate (C₃₂H₄₀BrN₅O₅·CH₄O₃S), calculated on the dried basis.

Description Bromocriptine Mesilate occurs as a white to pale yellowish white or pale brownish white crystalline powder. It is odorless, or has a faint characteristic odor.

It is very soluble in acetic acid (100), freely soluble in methanol, sparingly soluble in ethanol (95), very slightly soluble in acetic anhydride, in dichloromethane and in chloroform, and practically insoluble in water and in diethyl ether.

It is gradually colored by light.

Identification (1) Dissolve 2 mg of Bromocriptine Mesilate in 1 mL of methanol, add 2 mL of 4-dimethylaminobenzaldehyde-ferric chloride TS, and shake: a purplish blue color develops.

(2) Determine the absorption spectrum of a solution of Bromocriptine Mesilate in methanol (3 in 100,000) as directed under Ultraviolet-visible Spectrophotometry <2.24>, and compare the spectrum with the Reference Spectrum: both spectra exhibit similar intensities of absorption at the same wavelengths.

(3) Determine the infrared absorption spectrum of Bromocriptine Mesilate as directed in the paste method under Infrared Spectrophotometry <2.25>, and compare the spectrum with the Reference Spectrum: both spectra exhibit similar intensities of absorption at the same wave numbers.

(4) Perform the test with Bromocriptine Mesilate as directed under Flame Coloration Test <1.04> (2): a green color appears.

Optical rotation <2.49> [α]_D²⁰: +95 – +105° [0.1 g, calculated on the dried basis, a mixture of methanol and dichloromethane (1:1), 10 mL, 100 mm].

Purity (1) Clarity and color of solution—Dissolve 0.10 g of Bromocriptine Mesilate in 10 mL of methanol: the solution is clear, and has no more color than the following control solution.

Control solution: To 2.5 mL of Cobalt (II) Chloride CS, 6.0 mL of Iron (III) Chloride CS and 1.0 mL of Copper (II) Sulfate CS add diluted hydrochloric acid (1 in 40) to make exactly 100 mL.

(2) Heavy metals <1.07>—Proceed with 1.0 g of Bromocriptine Mesilate according to Method 2, and perform the test. Prepare the control solution with 2.0 mL of Standard Lead Solution (not more than 20 ppm).

(3) Related substances—Conduct this procedure without exposure to light, using light-resistant vessels. Dissolve 0.10 g of Bromocriptine Mesilate in 10 mL of a mixture of methanol and chloroform (1:1), and use this solution as the sample solution. Pipet 1 mL of the sample solution, add a mixture of methanol and chloroform (1:1) to make exactly 200 mL, and use this solution as the standard solution (1). Pipet 10 mL of the standard solution (1), add a mixture of methanol and chloroform (1:1) to make exactly 20 mL, and use this solution as the standard solution (2). Perform the test with these solutions as directed under Thin-layer Chromatography <2.03>. Spot 10 μ L each of the sample solution and standard solutions (1) and (2), as a band with 1 cm in width, on a plate of silica gel for thin-layer chromatography. Develop the plate immediately with a mixture of dichloromethane, 1,4-dioxane, ethanol (95) and ammonia solution (28) (1800:150:50:1) to a distance of about 10 cm, and dry the plate under reduced pressure for 30 minutes. Spray evenly Dragendorff's TS for spraying on the plate, then spray evenly hydrogen peroxide TS, cover the plate with a glass plate, and examine: the spots other than the principal spot obtained from the sample solution are not more intense than the spot from the standard solution (1), and the spot other than the principal spot, which is more intense than the spot from the standard solution (2), is not more than one.

Loss on drying <2.41> Not more than 3.0% (1 g, in vacuum at a pressure not exceeding 0.67 kPa, 80°C, 5 hours).

Residue on ignition <2.44> Not more than 0.1% (1 g).

Assay Weigh accurately about 0.6 g of Bromocriptine Mesilate, dissolve in 80 mL of a mixture of acetic anhydride and acetic acid (100) (7:1), and titrate <2.50> with 0.1 mol/L perchloric acid VS (potentiometric titration). Perform a blank determination in the same manner, and make any necessary correction.

Each mL of 0.1 mol/L perchloric acid VS
= 75.07 mg of $C_{32}H_{40}BrN_5O_5 \cdot CH_4O_3S$

Containers and storage Containers—Tight containers.

Storage—Light-resistant, and not exceeding -18°C .

Bromovalerylurea

ブロモバレリル尿素

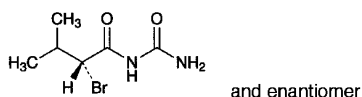

$C_6H_{11}BrN_2O_2$: 223.07

(2*R*,3*S*)-(2-Bromo-3-methylbutanoyl)urea

[496-67-3]

Bromovalerylurea, when dried, contains not less than 98.0% of bromovalerylurea ($C_6H_{11}BrN_2O_2$).

Description Bromovalerylurea occurs as colorless or white, crystals or crystalline powder. It is odorless, and has a slightly bitter taste.

It is soluble in ethanol (95), sparingly soluble in diethyl ether, and very slightly soluble in water.

It dissolves in sulfuric acid, in nitric acid and in hydrochloric acid, and precipitates are produced on the addition of water.

It dissolves in sodium hydroxide TS.

Identification (1) Boil 0.2 g of Bromovalerylurea with 5 mL of a solution of sodium hydroxide (1 in 10); the gas evolved changes moistened red litmus paper to blue. Boil this solution with an excess of dilute sulfuric acid: the odor of valeric acid is perceptible.

(2) To 0.1 g of Bromovalerylurea add 0.5 g of anhydrous sodium carbonate, and decompose thoroughly by gentle heating. Dissolve the residue in 5 mL of hot water, cool, acidify with acetic acid (31), and filter: the filtrate responds to Qualitative Tests <1.09> (2) for bromide.

Melting point <2.60> 151 – 155°C

Purity (1) Acidity or alkalinity—To 1.5 g of Bromovalerylurea add 30 mL of water, shake for 5 minutes, and filter: the filtrate is neutral.

(2) Chloride <1.03>—Perform the test with a 10-mL portion of the filtrate obtained in (1). Prepare the control solution with 0.40 mL of 0.01 mol/L hydrochloric acid VS (not more than 0.028%).

(3) Sulfate <1.14>—Perform the test with 10 mL of the filtrate obtained in (1). Prepare the control solution with 0.40 mL of 0.005 mol/L sulfuric acid VS (not more than 0.038%).

(4) Heavy metals <1.07>—Proceed with 2.0 g of Bromovalerylurea according to Method 2, and perform the test. Prepare the control solution with 2.0 mL of Standard Lead Solution (not more than 10 ppm).

(5) Arsenic <1.11>—Dissolve 0.5 g of Bromovalerylurea in 5 mL of sodium hydroxide TS, use this solution as the test solution, and perform the test (not more than 4 ppm).

(6) Readily carbonizable substances <1.15>—Perform the test with 0.5 g of Bromovalerylurea: the solution is not more colored than Matching Fluid A.

Loss on drying <2.41> Not more than 0.5% (1 g, 80°C, 2 hours).

Residue on ignition <2.44> Not more than 0.1% (1 g).

Assay Weigh accurately about 0.4 g of Bromovalerylurea, previously dried, in a 300-mL conical flask, add 40 mL of sodium hydroxide TS, and boil gently for 20 minutes under a reflux condenser. Cool, wash the lower part of the reflux condenser and the mouth of the flask with 30 mL of water, and combine the washings with the solution in the conical flask. Add 5 mL of nitric acid and exactly 30 mL of 0.1 mol/L silver nitrate VS, and titrate <2.50> the excess silver nitrate with 0.1 mol/L ammonium thiocyanate VS (indicator: 2 mL of ammonium iron (III) sulfate TS). Perform a blank determination in the same manner.

Each mL of 0.1 mol/L silver nitrate VS
= 22.31 mg of $C_6H_{11}BrN_2O_2$

Containers and storage Containers—Well-closed containers.

Brotizolam

プロチゾラム

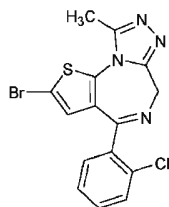

$C_{15}H_{10}BrClN_4S$: 393.69

2-Bromo-4-(2-chlorophenyl)-9-methyl-6*H*-thieno[3,2-*f*][1,2,4]triazolo[4,3-*a*][1,4]diazepine [57801-81-7]

Brotizolam, when dried, contains not less than 98.5% and not more than 101.0% of brotizolam ($C_{15}H_{10}BrClN_4S$).

Description Brotizolam occurs as a white or pale yellow crystalline powder.

It is sparingly soluble in methanol, slightly soluble in acetonitrile and in ethanol (99.5), and practically insoluble in water.

Identification (1) Determine the absorption spectrum of a solution of Brotizolam in methanol (1 in 100,000) as directed under Ultraviolet-visible Spectrophotometry <2.24>, and compare the spectrum with the Reference Spectrum: both spectra exhibit similar intensities of absorption at the same wavelengths.

(2) Determine the infrared absorption spectrum of Brotizolam as directed in the potassium bromide disk method under Infrared Spectrophotometry <2.25>, and compare the spectrum with the Reference Spectrum: both spectra exhibit similar intensities of absorption at the same wave numbers.

Melting point <2.60> 208 – 212°C

Purity (1) Heavy metals <1.07>—Proceed with 2.0 g of Brotizolam according to Method 2, and perform the test. Prepare the control solution with 2.0 mL of Standard Lead Solution (not more than 10 ppm).

(2) Related substances—Dissolve 50 mg of Brotizolam in 50 mL of acetonitrile, and use this solution as the sample solution. Pipet 2 mL of the sample solution, and add acetonitrile to make exactly 100 mL. Pipet 1 mL of this solution, add acetonitrile to make exactly 10 mL, and use this solution as the standard solution. Perform the test with exactly 5 μ L each of the sample solution and standard solution as directed under Liquid Chromatography <2.01> according to the following conditions. Determine each peak area by the automatic integration method: each peak area other than brotizolam obtained from the sample solution is not larger than 1/2 times the peak area of brotizolam from the standard solution, and the total area of the peaks other than brotizolam from the sample solution is not larger than the peak area of brotizolam from the standard solution.

Operating conditions—

Detector: An ultraviolet absorption photometer (wavelength: 242 nm).

Column: A stainless steel column 3.9 mm in inside diameter and 15 cm in length, packed with octylsilanized silica gel for liquid chromatography (5 μ m in particle diameter).

Column temperature: A constant temperature of about 40°C.

Mobile phase A: Dissolve 1.84 g of sodium 1-heptanesulfonate in 1000 mL of water.

Mobile phase B: Dissolve 0.46 g of sodium 1-heptanesulfonate in 250 mL of water and 750 mL of acetonitrile.

Flowing of mobile phase: Control the gradient by mixing the mobile phases A and B as directed in the following table.

Time after injection of sample (min)	Mobile phase A (vol%)	Mobile phase B (vol%)
0 – 4	63	37
4 – 15	63 → 12	37 → 88

Flow rate: About 2 mL per minute.

Time span of measurement: About 2 times as long as the retention time of brotizolam, beginning after the solvent peak.

System suitability—

Test for required detectability: Pipet 5 mL of the standard solution, and add acetonitrile to make exactly 20 mL. Confirm that the peak area of brotizolam obtained with 5 μ L of this solution is equivalent to 18 to 32% of that with 5 μ L of the standard solution.

System performance: When the procedure is run with 5 μ L of the standard solution under the above operating conditions, the number of theoretical plates and the symmetry factor of the peak of brotizolam are not less than 5000 and not more than 2.0, respectively.

System repeatability: When the test is repeated 6 times with 5 μ L of the standard solution under the above operating conditions, the relative standard deviation of the peak area of brotizolam is not more than 2.0%.

Loss on drying <2.41> Not more than 0.5% (1 g, 105°C, 3 hours).

Residue on ignition <2.44> Not more than 0.1% (1 g).

Assay Weigh accurately about 0.15 g of Brotizolam, previously dried, dissolve in 75 mL of a mixture of acetic anhydride and acetic acid (100) (2:1), and titrate <2.50> with 0.1 mol/L perchloric acid VS (potentiometric titration). Perform a blank determination in the same manner, and make any necessary correction.

Each mL of 0.1 mol/L perchloric acid VS
= 19.68 mg of $C_{15}H_{10}BrClN_4S$

Containers and storage Containers—Tight containers.

Storage—Light-resistant.

Brotizolam Tablets

プロチゾラム錠

Brotizolam Tablets contain not less than 95.0% and not more than 105.0% of the labeled amount of brotizolam ($C_{15}H_{10}BrClN_4S$: 393.69).

Method of preparation Prepare as directed under Tablets, with Brotizolam.

Identification Shake a quantity of powdered Brotizolam Tablets, equivalent to 0.1 mg of Brotizolam, with 10 mL of methanol, and centrifuge. Determine the absorption spectrum of the supernatant liquid as directed under Ultraviolet-visible Spectrophotometry <2.24>: it exhibits a maximum between 239 nm and 243 nm.

Purity Related substances—Use the sample solution obtained in the Assay as the sample solution. Pipet 1 mL of the sample solution, add the mobile phase to make exactly 100 mL, and use this solution as the standard solution. Perform the test with exactly 40 μ L each of the sample solution and standard solution as directed under Liquid Chromatography <2.01> according to the following conditions, and determine each peak area by the automatic integration method: the total area of the peaks other than brotizolam obtained from the sample solution is not larger than 1.5 times the peak area of brotizolam from the standard solution.

Operating conditions—

Detector, column, column temperature, mobile phase, and flow rate: Proceed as directed in the operating conditions in the Assay.

Time span of measurement: About 3 times as long as the retention time of brotizolam, beginning after the solvent peak.

System suitability—

Test for required detectability: To exactly 10 mL of the standard solution add the mobile phase to make exactly 100 mL. Confirm that the peak area of brotizolam obtained with 40 μ L of this solution is equivalent to 7 to 13% of that obtained with 40 μ L of the standard solution.

System performance: When the procedure is run with 40 μ L of the standard solution under the above operating conditions, the number of theoretical plates and the symmetry factor of the peak of brotizolam are not less than 3000 and not more than 2.0, respectively.

System repeatability: When the test is repeated 6 times with 40 μ L of the standard solution under the above operating conditions, the relative standard deviation of the peak area of brotizolam is not more than 2.0%.

Uniformity of dosage units <6.02> Perform the test according to the following method: it meets the requirement of the Content uniformity test.

To 1 tablet of Brotizolam Tablets add exactly V mL of the mobile phase so that each mL contains about 25 μ g of brotizolam ($C_{15}H_{10}BrClN_4S$), shake for 15 minutes, centrifuge, and use the supernatant liquid as the sample solution. Then, proceed as directed in the Assay.

$$\begin{aligned} &\text{Amount (mg) of brotizolam (C}_{15}\text{H}_{10}\text{BrClN}_4\text{S)} \\ &= M_S \times A_T/A_S \times V/1000 \end{aligned}$$

M_S : Amount (mg) of brotizolam for assay taken

Dissolution <6.10> When the test is performed at 50 revolutions per minute according to the Paddle method, using 900 mL of water as the dissolution medium, the dissolution rate in 15 minutes of Brotizolam Tablets is not less than 85%.

Start the test with 1 tablet of Brotizolam Tablets, withdraw not less than 20 mL of the medium at the specified minute after starting the test, and filter through a membrane filter with a pore size not exceeding 0.5 μ m. Discard not less than 10 mL of the first filtrate, pipet V mL of the subsequent filtrate, add water to make exactly V' mL so that each mL contains about 0.14 μ g of brotizolam ($C_{15}H_{10}BrClN_4S$), and use this solution as the sample solution. Separately, weigh accurately about 28 mg of brotizolam for assay, previously dried at 105°C for 3 hours, dissolve in 10 mL of methanol, and add water to make exactly 100 mL. Pipet 5 mL of this solution, add water to make exactly 200 mL. Pipet 2 mL of this solution, add water to make exactly 100 mL, and use this solution as the standard solution. Perform the test with exactly 200 μ L each of the sample solution and standard solution as directed under Liquid Chromatography <2.01> according to the following conditions, and determine the peak

areas, A_T and A_S , of brotizolam in each solution.

Dissolution rate (%) with respect to the labeled amount of brotizolam ($C_{15}H_{10}BrClN_4S$)

$$= M_S \times A_T/A_S \times V'/V \times 1/C \times 9/20$$

M_S : Amount (mg) of brotizolam for assay taken

C : Labeled amount (mg) of brotizolam ($C_{15}H_{10}BrClN_4S$) in 1 tablet

Operating conditions—

Detector, column, and column temperature: Proceed as directed in the operating conditions in the Assay.

Mobile phase: A mixture of water and acetonitrile (63:37).

Flow rate: Adjust so that the retention time of brotizolam is about 7 minutes.

System suitability—

System performance: When the procedure is run with 200 μ L of the standard solution under the above operating conditions, the number of theoretical plates and the symmetry factor of the peak of brotizolam are not less than 2000 and not more than 2.0, respectively.

System repeatability: When the test is repeated 6 times with 200 μ L of the standard solution under the above operating conditions, the relative standard deviation of the peak area of brotizolam is not more than 2.0%.

Assay Weigh accurately the mass of not less than 20 Brotizolam Tablets, and powder. Weigh accurately a portion of the powder, equivalent to about 0.25 mg of brotizolam ($C_{15}H_{10}BrClN_4S$), add exactly 10 mL of the mobile phase, and shake for 15 minutes. Centrifuge this solution, and use the supernatant liquid as the sample solution. Separately, weigh accurately about 25 mg of brotizolam for assay, previously dried at 105°C for 3 hours, and dissolve in the mobile phase to make exactly 50 mL. Pipet 5 mL of this solution, add the mobile phase to make exactly 100 mL, and use this solution as the standard solution. Perform the test with exactly 40 μ L each of the sample solution and standard solution as directed under Liquid Chromatography <2.01> according to the following conditions, and determine the peak areas, A_T and A_S , of brotizolam in each solution.

$$\begin{aligned} &\text{Amount (mg) of brotizolam (C}_{15}\text{H}_{10}\text{BrClN}_4\text{S)} \\ &= M_S \times A_T/A_S \times 1/100 \end{aligned}$$

M_S : Amount (mg) of brotizolam for assay taken

Operating conditions—

Detector: An ultraviolet absorption photometer (wavelength: 240 nm).

Column: A stainless steel column 4.6 mm in inside diameter and 15 cm in length, packed with octadecylsilanized silica gel for liquid chromatography (5 μ m in particle diameter).

Column temperature: A constant temperature of about 30°C.

Mobile phase: Dissolve 1.1 g of ammonium carbonate in 1000 mL of water. To 600 mL of this solution add 500 mL of acetonitrile.

Flow rate: Adjust so that the retention time of brotizolam is about 3 minutes.

System suitability—

System performance: When the procedure is run with 40 μ L of the standard solution under the above operating conditions, the number of theoretical plates and the symmetry factor of the peak of brotizolam are not less than 3000 and not more than 2.0, respectively.

System repeatability: When the test is repeated 6 times with 40 μ L of the standard solution under the above operating conditions, the relative standard deviation of the peak

area of brotizolam is not more than 1.0%.

Containers and storage Containers—Tight containers.
Storage—Light-resistant.

Bucillamine

ブシラミン

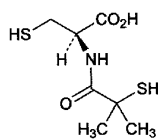

$C_7H_{13}NO_3S_2$: 223.31
(2*R*)-2-(2-Methyl-2-sulfanylpropanoylamino)-3-sulfanylpropanoic acid
[65002-17-7]

Bucillamine, when dried, contains not less than 98.5% and not more than 101.0% of bucillamine ($C_7H_{13}NO_3S_2$).

Description Bucillamine occurs as white, crystals or crystalline powder.

It is freely soluble in methanol and in ethanol (95), and slightly soluble in water.

Identification (1) To 5 mL of a solution of Bucillamine (1 in 250) add 2 mL of sodium hydroxide TS and 2 drops of sodium pentacyanonitrosylferrate (III) TS: the solution reveals a red-purple color.

(2) Determine the infrared absorption spectrum of Bucillamine as directed in the potassium bromide disk method under Infrared Spectrophotometry <2.25>, and compare the spectrum with the Reference Spectrum: both spectra exhibit similar intensities of absorption at the same wave numbers.

Optical rotation <2.49> $[\alpha]_D^{20}$: +33.0 – +36.5° (after drying, 2 g, ethanol (95), 50 mL, 100 mm).

Melting point <2.60> 136 – 140°C

Purity (1) Heavy metals <1.07>—Proceed with 1.0 g of Bucillamine according to Method 2, and perform the test. Prepare the control solution with 2.0 mL of Standard Lead Solution (not more than 20 ppm).

(2) Arsenic <1.11>—Prepare the test solution with 1.0 g of Bucillamine according to Method 3, and perform the test (not more than 2 ppm).

(3) Related substances—Dissolve 60 mg of Bucillamine in 20 mL of a mixture of water and methanol (1:1), and use this solution as the sample solution. Pipet 3 mL of the sample solution, add the mixture of water and methanol (1:1) to make exactly 200 mL, and use this solution as the standard solution. Immediately perform the test with exactly 20 μ L each of the sample solution and standard solution as directed under Liquid Chromatography <2.01> according to the following conditions, and determine each peak area by the automatic integration method: the peak areas of related substances, having the relative retention time of about 2.3 and about 3.1 to bucillamine, obtained from the sample solution are not larger than 8/15 times and 2/5 times the peak area of bucillamine from the standard solution, respectively, and the area of the peak other than the bucillamine and the peaks mentioned above from the sample solution is not larger than 1/5 times the peak area of bucillamine from the standard solution. The total area of the peaks other than bucillamine from the sample solution is not larger than the peak area of

bucillamine from the standard solution.

Operating conditions—

Detector: An ultraviolet absorption photometer (wavelength: 254 nm).

Column: A stainless steel column 6.0 mm in inside diameter and 15 cm in length, packed with octadecylsilanized silica gel for liquid chromatography (5 μ m in particle diameter).

Column temperature: A constant temperature of about 40°C.

Mobile phase: A mixture of 0.01 mol/L citric acid TS and methanol (1:1).

Flow rate: Adjust so that the retention time of bucillamine is about 5 minutes.

Time span of measurement: About 7 times as long as the retention time of bucillamine, beginning after the solvent peak.

System suitability—

Test for required detectability: To exactly 1 mL of the standard solution add the mixture of water and methanol (1:1) to make exactly 10 mL. Confirm that the peak area of bucillamine obtained with 20 μ L of this solution is equivalent to 7 to 13% of that with 20 μ L of the standard solution.

System performance: Dissolve 0.10 g of bucillamine and 10 mg of 4-fluorobenzoic acid in 100 mL of methanol. To 10 mL of this solution add water to make exactly 50 mL. When the procedure is run with 20 μ L of this solution under the above operating conditions, bucillamine and 4-fluorobenzoic acid are eluted in this order with the resolution between these peaks being not less than 3.

System repeatability: When the test is repeated 6 times with 20 μ L of the standard solution under the above operating conditions, the relative standard deviation of the peak area of bucillamine is not more than 2.0%.

Loss on drying <2.41> Not more than 0.5% (1 g, in vacuum, phosphorus (V) oxide, 60°C, 6 hours).

Residue on ignition <2.44> Not more than 0.1% (1 g).

Assay Weigh accurately about 0.25 g of Bucillamine, dissolve in 35 mL of methanol, add 15 mL of water, and titrate <2.50> with 0.05 mol/L iodine VS (potentiometric titration). Perform a blank determination in the same manner, and make any necessary correction.

Each mL of 0.05 mol/L iodine VS
= 11.17 mg of $C_7H_{13}NO_3S_2$

Containers and storage Containers—Tight containers.

Bucillamine Tablets

ブシラミン錠

Bucillamine Tablets contain not less than 95.0% and not more than 105.0% of the labeled amount of bucillamine ($C_7H_{13}NO_3S_2$: 223.31).

Method of preparation Prepare as directed under Tablets, with Bucillamine.

Identification (1) To a quantity of powdered Bucillamine Tablets, equivalent to 0.1 g of Bucillamine, add 0.1 g of sodium hydrogen carbonate and 10 mL of water, shake well, filter, and add 1 or 2 drops of ninhydrin TS to the filtrate: it exhibits a red-brown color.

(2) To a quantity of powdered Bucillamine Tablets, equivalent to 0.1 g of Bucillamine, add 25 mL of water, shake well, and filter. To 5 mL of the filtrate, add 2 mL of

dilute sodium hydroxide TS and 1 or 2 drops of sodium pentacyanonitrosylferrate (III) TS: it exhibits a red-purple color.

Uniformity of dosage units <6.02>—Perform the Mass variation test, or the Content uniformity test according to the following method: it meets the requirement.

Store the sample solution and standard solution in a cold place until performing the measurements. Take 1 tablet of Bucillamine Tablets, add exactly 1 mL of the internal standard solution per 0.1 g of bucillamine ($C_7H_{13}NO_3S_2$), then add 3 mL of water and 6 mL of methanol per 0.1 g of bucillamine ($C_7H_{13}NO_3S_2$), and stir well until the tablet completely disintegrated. To 1 mL of this solution add the mobile phase to make 25 mL, filter through a membrane filter with a pore size not exceeding $0.45\ \mu\text{m}$, and use the filtrate as the sample solution. Then, proceed as directed in the Assay.

$$\begin{aligned} &\text{Amount (mg) of bucillamine } (C_7H_{13}NO_3S_2) \\ &= M_S \times Q_T/Q_S \times C \times 1/200 \end{aligned}$$

M_S : Amount (mg) of bucillamine for assay taken

C: Labeled amount (mg) of bucillamine ($C_7H_{13}NO_3S_2$) in 1 tablet

Internal standard solution—A solution of 4-fluorobenzoic acid in methanol (1 in 100).

Dissolution <6.10>—When the test is performed at 50 revolutions per minute according to the Paddle method, using 900 mL of water as the dissolution medium, the dissolution rate in 30 minutes of Bucillamine Tablets is not less than 80%.

Store the sample solution and standard solution in a cold place until performing the measurements. Start the test with 1 tablet of Bucillamine Tablets, withdraw not less than 20 mL of the medium at the specified minute after starting the test, and filter through a membrane filter with a pore size not exceeding $0.45\ \mu\text{m}$. Discard not less than 10 mL of the first filtrate, and use the subsequent filtrate as the sample solution. Separately, weigh accurately an amount of bucillamine for assay equivalent to the labeled amount of the tablet, previously dried in vacuum at 60°C for 6 hours using phosphorus (V) oxide as a desiccant, and dissolve in methanol to make exactly 10 mL. Pipet 1 mL of this solution, add water to make exactly 100 mL, and use this solution as the standard solution. Perform the test with exactly $20\ \mu\text{L}$ each of the sample solution and standard solution as directed under Liquid Chromatography <2.01> according to the following conditions, and determine the peak areas, A_T and A_S , of bucillamine in each solution.

$$\begin{aligned} &\text{Dissolution rate (\%)} \text{ with respect to the labeled amount} \\ &\text{of bucillamine } (C_7H_{13}NO_3S_2) \\ &= M_S \times A_T/A_S \times 1/C \times 90 \end{aligned}$$

M_S : Amount (mg) of bucillamine for assay taken

C: Labeled amount (mg) of bucillamine ($C_7H_{13}NO_3S_2$) in 1 tablet

Operating conditions—

Detector, column, and column temperature: Proceed as directed in the operating conditions in the Assay.

Mobile phase: A mixture of diluted phosphoric acid (1 in 1000) and methanol (11:9).

Flow rate: Adjust so that the retention time of bucillamine is about 4 minutes.

System suitability—

System performance: When the procedure is run with 20 μL of the standard solution under the above operating conditions, the number of theoretical plates and the symmetry factor of the peak of bucillamine are not less than 3000 and

not more than 1.5, respectively.

System repeatability: When the test is repeated 6 times with $20\ \mu\text{L}$ of the standard solution under the above operating conditions, the relative standard deviation of the peak area of bucillamine is not more than 2.0%.

Assay Store the sample solution and standard solution in a cold place until performing the measurements. Take 10 tablets of Bucillamine Tablets, add exactly 1 mL of the internal standard solution per 0.1 g of bucillamine ($C_7H_{13}NO_3S_2$), add 3 mL of water and 6 mL of methanol, and stir well until the tablets completely disintegrated. To 1 mL of this solution add the mobile phase to make 25 mL, filter through a membrane filter with a pore size not exceeding $0.45\ \mu\text{m}$, and use this solution as the sample solution. Separately, weigh accurately about 0.2 g of bucillamine for assay, previously dried in vacuum at 60°C for 6 hours using phosphorus (V) oxide as a desiccant, add exactly 2 mL of the internal standard solution, and add 6 mL of water and 12 mL of methanol. To 1 mL of this solution add the mobile phase to make 25 mL, filter through a membrane filter with a pore size not exceeding $0.45\ \mu\text{m}$, and use this solution as the standard solution. Perform the test with $10\ \mu\text{L}$ each of the sample solution and standard solution as directed under Liquid Chromatography <2.01> according to the following conditions, and calculate the ratios, Q_T and Q_S , of the peak area of bucillamine to that of the internal standard.

$$\begin{aligned} &\text{Amount (mg) of bucillamine } (C_7H_{13}NO_3S_2) \\ &= M_S \times Q_T/Q_S \times C \times 1/200 \end{aligned}$$

M_S : Amount (mg) of bucillamine for assay taken

C: Labeled amount (mg) of bucillamine ($C_7H_{13}NO_3S_2$) in 1 tablet

Internal standard solution—A solution of 4-fluorobenzoic acid in methanol (1 in 100).

Operating conditions—

Detector: An ultraviolet absorption photometer (wavelength: 254 nm).

Column: A stainless steel column 4.6 mm in inside diameter and 15 cm in length, packed with octadecylsilanized silica gel for liquid chromatography ($5\ \mu\text{m}$ in particle diameter).

Column temperature: A constant temperature of about 40°C .

Mobile phase: A mixture of diluted phosphoric acid (1 in 1000) and methanol (3:2).

Flow rate: Adjust so that the retention time of bucillamine is about 5 minutes.

System suitability—

System performance: When the procedure is run with $10\ \mu\text{L}$ of the standard solution under the above operating conditions, bucillamine and the internal standard are eluted in this order with the resolution between these peaks being not less than 3.

System repeatability: When the test is repeated 6 times with $10\ \mu\text{L}$ of the standard solution under the above operating conditions, the relative standard deviation of the ratio of the peak area of bucillamine to that of the internal standard is not more than 1.0%.

Containers and storage Containers—Tight containers.

Bucumolol Hydrochloride

ブクモロール塩酸塩

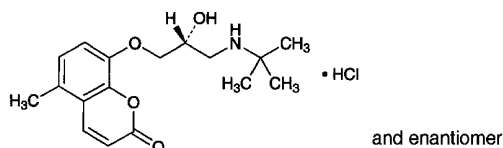

$C_{17}H_{23}NO_4 \cdot HCl$: 341.83

8-[(2*RS*)-3-[(1,1-Dimethylethyl)amino]-2-hydroxypropoxy]-5-methylchromen-2-one monohydrochloride
[36556-75-9]

Bucumolol Hydrochloride, when dried, contains not less than 99.0% of bucumolol hydrochloride ($C_{17}H_{23}NO_4 \cdot HCl$).

Description Bucumolol Hydrochloride occurs as white, crystals or crystalline powder.

It is freely soluble in water, sparingly soluble in methanol and in ethanol (95), slightly soluble in acetic acid (100), and practically insoluble in diethyl ether.

Melting point: about 228°C (with decomposition).

Identification (1) Dissolve 0.01 g of Bucumolol Hydrochloride in 10 mL of diluted ethanol (95) (1 in 2), and observe under ultraviolet light (main wavelength: 365 nm): the solution shows a yellow-green fluorescence. Render this solution alkaline by adding sodium hydroxide TS: the fluorescence disappears. Acidify the solution by adding dilute hydrochloric acid: the fluorescence reappears.

(2) Dissolve 0.1 g of Bucumolol Hydrochloride in 5 mL of water, and add 5 drops of Reinecke salt TS: a light red precipitate is formed.

(3) Determine the absorption spectrum of a solution of Bucumolol Hydrochloride (1 in 60,000) as directed under Ultraviolet-visible Spectrophotometry <2.24>, and compare the spectrum with the Reference Spectrum: both spectra exhibit similar intensities of absorption at the same wavelengths.

(4) Determine the infrared absorption spectrum of Bucumolol Hydrochloride, previously dried, as directed in the potassium chloride disk method under Infrared Spectrophotometry <2.25>, and compare the spectrum with the Reference Spectrum: both spectra exhibit similar intensities of absorption at the same wave numbers.

(5) A solution of Bucumolol Hydrochloride (1 in 50) responds to Qualitative Tests <1.09> for chloride.

Absorbance <2.24> $E_{1\text{cm}}^{1\%}$ (296 nm): 330 – 360 (after drying, 40 mg, water, 2500 mL).

Purity (1) Clarity and color of solution—Dissolve 1.0 g of Bucumolol Hydrochloride in 20 mL of water: the solution is clear and colorless to pale yellow.

(2) Heavy metals <1.07>—Proceed with 1.0 g of Bucumolol Hydrochloride according to Method 2, and perform the test. Prepare the control solution with 2.0 mL of Standard Lead Solution (not more than 20 ppm).

(3) Arsenic <1.11>—Prepare the test solution with 1.0 g of Bucumolol Hydrochloride according to Method 3, and perform the test (not more than 2 ppm).

(4) Related substances—Dissolve 0.10 g of Bucumolol Hydrochloride in 10 mL of methanol, and use this solution as the sample solution. Pipet 1 mL of the sample solution, and add methanol to make exactly 50 mL. Pipet 5 mL of this

solution, add methanol to make exactly 25 mL, and use this solution as the standard solution. Perform the test with these solutions as directed under Thin-layer Chromatography <2.03>. Spot 5 μL each of the sample solution and standard solution on a plate of silica gel with fluorescent indicator for thin-layer chromatography. Develop the plate with a mixture of methanol and ammonia-ammonium chloride buffer solution (pH 10.7) (30:1) to a distance of about 12 cm, and air-dry the plate. Examine under ultraviolet light (main wavelength: 254 nm): the spots other than the principal spot obtained from the sample solution are not more intense than the spot from the standard solution.

Loss on drying <2.41> Not more than 0.5% (1 g, 105°C, 5 hours).

Residue on ignition <2.44> Not more than 0.1% (1 g).

Assay Weigh accurately about 0.4 g of Bucumolol Hydrochloride, previously dried, add 45 mL of acetic acid (100), dissolve by warming at 60°C, and cool. Add 105 mL of acetic anhydride, and titrate <2.50> with 0.1 mol/L perchloric acid VS (potentiometric titration). Perform a blank determination in the same manner, and make any necessary correction.

Each mL of 0.1 mol/L perchloric acid VS
= 34.18 mg of $C_{17}H_{23}NO_4 \cdot HCl$

Containers and storage Containers—Well-closed containers.

Bufetolol Hydrochloride

ブフェトロール塩酸塩

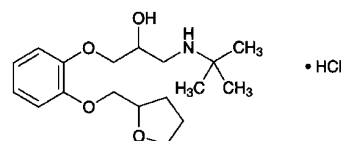

$C_{18}H_{29}NO_4 \cdot HCl$: 359.89

1-(1,1-Dimethylethyl)amino-3-[2-(tetrahydrofuran-2-ylmethoxy)phenoxy]propan-2-ol monohydrochloride
[35108-88-4]

Bufetolol Hydrochloride, when dried, contains not less than 98.5% of bufetolol hydrochloride ($C_{18}H_{29}NO_4 \cdot HCl$).

Description Bufetolol Hydrochloride occurs as white, crystals or crystalline powder.

It is freely soluble in water and in methanol, soluble in ethanol (95) and in acetic acid (100), and practically insoluble in diethyl ether.

A solution of Bufetolol Hydrochloride (1 in 10) shows no optical rotation.

Identification (1) To 5 mL of a solution of Bufetolol Hydrochloride (1 in 100) add 5 drops of Reinecke salt TS: a light red precipitate is formed.

(2) Determine the absorption spectrum of a solution of Bufetolol Hydrochloride (1 in 20,000) as directed under Ultraviolet-visible Spectrophotometry <2.24>, and compare the spectrum with the Reference Spectrum: both spectra exhibit similar intensities of absorption at the same wavelengths.

(3) Determine the infrared absorption spectrum of Bufetolol Hydrochloride, previously dried, as directed in the potassium chloride disk method under Infrared Spectropho-

tometry <2.25>, and compare the spectrum with the Reference Spectrum: both spectra exhibit similar intensities of absorption at the same wave numbers.

(4) A solution of Bufetolol Hydrochloride (1 in 50) responds to Qualitative Tests <1.09> for chloride.

Melting point <2.60> 153 – 157°C

Purity (1) Clarity and color of solution—Dissolve 1.0 g of Bufetolol Hydrochloride in 10 mL of water: the solution is clear and colorless.

(2) Sulfate <1.14>—Perform the test with 0.5 g of Bufetolol Hydrochloride. Prepare the control solution with 0.40 mL of 0.005 mol/L sulfuric acid VS (not more than 0.038%).

(3) Heavy metals <1.07>—Proceed with 2.0 g of Bufetolol Hydrochloride according to Method 2, and perform the test. Prepare the control solution with 2.0 mL of Standard Lead Solution (not more than 10 ppm).

(4) Related substances—Dissolve 0.20 g of Bufetolol Hydrochloride in 5 mL of methanol, and use this solution as the sample solution. Pipet 1 mL of the sample solution, add methanol to make exactly 200 mL, and use this solution as the standard solution. Perform the test with these solutions as directed under Thin-layer Chromatography <2.03>. Spot 10 µL each of the sample solution and standard solution on a plate of silica gel with fluorescent indicator for thin-layer chromatography. Develop the plate with a mixture of chloroform, acetone, ethanol (95) and ammonia solution (28) (40:20:5:1) to a distance of about 10 cm, and air-dry the plate. Examine under ultraviolet light (main wavelength: 254 nm): the spots other than the principal spot obtained from the sample solution are not more intense than the spot from the standard solution.

Loss on drying <2.41> Not more than 0.5% (1 g, 105°C, 4 hours).

Residue on ignition <2.44> Not more than 0.1% (1 g).

Assay Weigh accurately about 0.4 g of Bufetolol Hydrochloride, previously dried, dissolve in 10 mL of acetic acid (100), add 50 mL of acetic anhydride, and titrate <2.50> with 0.1 mol/L perchloric acid VS (potentiometric titration). Perform a blank determination in the same manner, and make any necessary correction.

Each mL of 0.1 mol/L perchloric acid VS
= 35.99 mg of C₁₈H₂₉NO₄.HCl

Containers and storage Containers—Tight containers.

Buformin Hydrochloride

ブホルミン塩酸塩

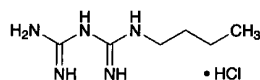

C₆H₁₅N₅.HCl: 193.68

1-Butylbiguanide hydrochloride
[1190-53-0]

Buformin Hydrochloride, when dried, contains not less than 98.5% and not more than 101.0% of buformin hydrochloride (C₆H₁₅N₅.HCl).

Description Buformin Hydrochloride occurs as a white crystalline powder.

It is freely soluble in water and in ethanol (99.5).

Identification (1) To 5 mL of a solution of Buformin Hydrochloride (1 in 2000) add 1 mL of dilute sodium pentacyanonitrosylferrate (III)-potassium hexacyanoferrate (III) TS: a red-brown color develops.

(2) Determine the absorption spectrum of a solution of Buformin Hydrochloride (1 in 125,000) as directed under Ultraviolet-visible Spectrophotometry <2.24>, and compare the spectrum with the Reference Spectrum: both spectra exhibit similar intensities of absorption at the same wavelengths.

(3) Determine the infrared absorption spectrum of Buformin Hydrochloride as directed in the potassium chloride disk method under Infrared Spectrophotometry <2.25>, and compare the spectrum with the Reference Spectrum: both spectra exhibit similar intensities of absorption at the same wave numbers.

(4) A solution of Buformin Hydrochloride (1 in 20) responds to the Qualitative Tests <1.09> for chlorides.

Melting point <2.60> 175 – 180°C

Purity (1) Heavy metals <1.07>—Proceed with 1.0 g of Buformin Hydrochloride according to Method 1, and perform the test. Prepare the control solution with 2.0 mL of Standard Lead Solution (not more than 20 ppm).

(2) Arsenic <1.11>—Prepare the test solution with 1.0 g of Buformin Hydrochloride according to Method 1, and perform the test (not more than 2 ppm).

(3) Related substances—Dissolve 0.10 g of Buformin Hydrochloride in 200 mL of the mobile phase, and use this solution as the sample solution. Pipet 1 mL of the sample solution, add the mobile phase to make exactly 100 mL, and use this solution as the standard solution. Perform the test with exactly 10 µL each of the sample solution and standard solution as directed under Liquid Chromatography <2.01> according to the following conditions, and determine each peak area of both solutions by the automatic integration method: the area of the peak other than buformin obtained from the sample solution is not larger than 1/5 times the peak area of buformin from the standard solution. Furthermore, the total areas of all peaks other than the buformin peak from the sample solution is not larger than 1/2 times the peak area of buformin from the standard solution.

Operating conditions—

Detector: An ultraviolet absorption photometer (wavelength: 230 nm).

Column: A stainless steel column 4.6 mm in inside diameter and 15 cm in length, packed with octadecylsilanized silica gel for liquid chromatography (5 µm in particle diameter).

Column temperature: A constant temperature of about 35°C.

Mobile phase: A mixture of a solution of sodium perchlorate monohydrate in diluted phosphoric acid (1 in 1000) (7 in 250) and acetonitrile (7:1).

Flow rate: Adjust so that the retention time of buformin is about 6 minutes.

Time span of measurement: About 2 times as long as the retention time of buformin, beginning after the solvent peak.

System suitability—

Test for required detectability: Pipet 1 mL of the standard solution, and add the mobile phase to make exactly 10 mL. Confirm that the peak area of buformin obtained with 10 µL of this solution is equivalent to 7 to 13% of that with 10 µL of the standard solution.

System performance: When the procedure is run with 10 µL of the standard solution under the above operating conditions, the number of theoretical plates and the symmetry factor of the peak of buformin are not less than 5000 and

not more than 2.0, respectively.

System repeatability: When the test is repeated 6 times with 10 μL of the standard solution under the above operating conditions, the relative standard deviation of the peak area of buformin is not more than 1.0%.

Loss on drying <2.41> Not more than 0.5% (1 g, 105°C, 3 hours).

Residue on ignition <2.44> Not more than 0.1% (1 g).

Assay Weigh accurately about 0.15 g of Buformin Hydrochloride, previously dried, dissolve in 50 mL of a mixture of acetic anhydride and acetic acid (100) (7:3), and immediately titrate <2.50> with 0.1 mol/L perchloric acid VS (potentiometric titration). Perform a blank determination in the same manner, and make any necessary correction.

$$\begin{aligned} \text{Each mL of 0.1 mol/L perchloric acid VS} \\ = 9.684 \text{ mg of } \text{C}_6\text{H}_{15}\text{N}_5\cdot\text{HCl} \end{aligned}$$

Containers and storage Containers—Tight containers.

Buformin Hydrochloride Delayed-release Tablets

ブホルミン塩酸塩腸溶錠

Buformin Hydrochloride Delayed-release Tablets contain not less than 93.0% and not more than 107.0% of the labeled amount of buformin hydrochloride ($\text{C}_6\text{H}_{15}\text{N}_5\cdot\text{HCl}$: 193.68).

Method of preparation Prepare as directed under Tablets, with Buformin Hydrochloride.

Identification To a quantity of powdered Buformin Hydrochloride Delayed-release Tablets, equivalent to 0.1 g of Buformin Hydrochloride, add 10 mL of water, shake well, and then filter. To 4 mL of the filtrate add 1 mL of a mixture of hydrogen peroxide TS, sodium pentacyanonitrosylferrate (III) TS and a solution of sodium hydroxide (1 in 10) (2:1:1): the solution exhibits a red to red-purple color.

Uniformity of dosage units <6.02> Perform the test according to the following method: it meets the requirement of the Content uniformity test.

To 1 tablet of Buformin Hydrochloride Delayed-release Tablets add 5 mL of a mixture of ethanol (99.5) and acetone (1:1), disperse the pellicle to smaller using ultrasonic waves, add exactly 10 mL of the internal standard solution per 50 mg of buformin hydrochloride ($\text{C}_6\text{H}_{15}\text{N}_5\cdot\text{HCl}$), and then add diluted acetonitrile (1 in 2) to make 13V/20 mL. Disintegrate the tablet using ultrasonic waves, then shake for 20 minutes, and add diluted acetonitrile (1 in 2) to make V mL so that each mL contains about 0.5 mg of buformin hydrochloride ($\text{C}_6\text{H}_{15}\text{N}_5\cdot\text{HCl}$) per mL. Centrifuge this solution, to 1 mL of the supernatant liquid, add the mobile phase to make 50 mL. If necessary, filter this solution through a membrane filter with a pore size not exceeding 0.5 μm , and use the filtrate as the sample solution. Then, proceed as directed in the Assay.

$$\begin{aligned} \text{Amount (mg) of buformin hydrochloride (C}_6\text{H}_{15}\text{N}_5\cdot\text{HCl)} \\ = M_S \times Q_T/Q_S \times V/50 \end{aligned}$$

M_S : Amount (mg) of buformin hydrochloride for assay taken

Internal standard solution—A solution of *p*-acetanisidide in diluted acetonitrile (1 in 2) (1 in 150).

Dissolution <6.10> When the tests are performed at 50 revolutions per minute according to the Paddle method, using 900 mL each of 1st fluid for dissolution test and 2nd fluid for dissolution test as the dissolution medium, the dissolution rate in 120 minutes of Buformin Hydrochloride Delayed-release Tablets using 1st fluid is not more than 5%, and that in 90 minutes of Buformin Hydrochloride Delayed-release Tablets using 2nd fluid is not less than 80%.

Start the test with 1 tablet of Buformin Hydrochloride Delayed-release Tablets, withdraw not less than 20 mL of the medium at the specified minute after starting the test, and filter through a membrane filter with a pore size not exceeding 0.5 μm . Discard not less than 10 mL of the first filtrate, pipet V mL of the subsequent filtrate, add the relevant dissolution medium to make exactly V' mL so that each mL contains about 56 μg of buformin hydrochloride ($\text{C}_6\text{H}_{15}\text{N}_5\cdot\text{HCl}$), and use this solution as the sample solution. Separately, weigh accurately about 28 mg of buformin hydrochloride for assay, previously dried at 105°C for 3 hours, and dissolve in the relevant dissolution medium to make exactly 100 mL. Pipet 4 mL of this solution, add the relevant dissolution medium to make exactly 20 mL, and use this solution as the standard solution. Perform the test with exactly 20 μL each of the sample solution and standard solution as directed under Liquid Chromatography <2.01> according to the following conditions, and determine the peak areas, A_T and A_S , of buformin in each solution.

$$\begin{aligned} \text{Dissolution rate (\%)} \text{ with respect to the labeled amount} \\ \text{of buformin hydrochloride (C}_6\text{H}_{15}\text{N}_5\cdot\text{HCl)} \\ = M_S \times A_T/A_S \times V'/V \times 1/C \times 180 \end{aligned}$$

M_S : Amount (mg) of buformin hydrochloride for assay taken

C: Labeled amount (mg) of buformin hydrochloride ($\text{C}_6\text{H}_{15}\text{N}_5\cdot\text{HCl}$) in 1 tablet

Operating conditions—

Detector: An ultraviolet absorption photometer (wavelength: 230 nm).

Column: A stainless steel column 4.6 mm in inside diameter and 15 cm in length, packed with octadecylsilanized silica gel for liquid chromatography (5 μm in particle diameter).

Column temperature: A constant temperature of about 35°C.

Mobile phase: A mixture of a solution of sodium perchlorate in diluted phosphoric acid (1 in 1000) (7 in 500) and acetonitrile (7:1).

Flow rate: Adjust so that the retention time of buformin is about 6 minutes.

System suitability—

System performance: When the procedure is run with 20 μL of the standard solution under the above operating conditions, the number of theoretical plates and the symmetry factor of the peak of buformin are not less than 3000 and not more than 2.0, respectively.

System repeatability: When the test is repeated 6 times with 20 μL of the standard solution under the above operating conditions, the relative standard deviation of the peak area of buformin is not more than 2.0%.

Assay Add 20 mL of a mixture of ethanol (99.5) and acetone (1:1) to an amount of Buformin Hydrochloride Delayed-release Tablets equivalent to 0.5 g of buformin hydrochloride ($\text{C}_6\text{H}_{15}\text{N}_5\cdot\text{HCl}$), disperse the pellicles to smaller using ultrasonic waves, and then add 100 mL of diluted acetonitrile (1 in 2). Disintegrate the tablets with the aid of ultrasonic waves, shake for 20 minutes, and then add diluted acetonitrile (1 in 2) to make exactly 200 mL. Centrifuge this

solution, pipet 10 mL of the supernatant liquid, add exactly 5 mL of the internal standard solution, and then add diluted acetonitrile (1 in 2) to make 50 mL. Pipet 1 mL of this solution, and add the mobile phase to make 50 mL. If necessary, filter this solution through a membrane filter with a pore size not exceeding 0.5 μm , and use the filtrate as the sample solution. Separately, weigh accurately about 25 mg of buformin hydrochloride for assay, previously dried at 105°C for 3 hours, dissolve in an adequate amount of diluted acetonitrile (1 in 2), add exactly 5 mL of the internal standard solution, and then add diluted acetonitrile (1 in 2) to make 50 mL. To 1 mL of this solution add the mobile phase to make 50 mL, and use this solution as the standard solution. Perform the test with 10 μL each of the sample solution and standard solution as directed under Liquid Chromatography <2.01> according to the following conditions, and calculate the ratios, Q_T and Q_S , of the peak area of buformin to that of the internal standard.

$$\begin{aligned} &\text{Amount (mg) of buformin hydrochloride (C}_6\text{H}_{15}\text{N}_5\text{.HCl)} \\ &= M_S \times Q_T/Q_S \times 20 \end{aligned}$$

M_S : Amount (mg) of buformin hydrochloride for assay taken

Internal standard solution—A solution of *p*-acetanisidide in diluted acetonitrile (1 in 2) (1 in 150).

Operating conditions—

Detector: An ultraviolet absorption photometer (wavelength: 233 nm).

Column: A stainless steel column 4.6 mm in inside diameter and 15 cm in length, packed with octadecylsilanized silica gel for liquid chromatography (5 μm in particle diameter).

Column temperature: A constant temperature of about 35°C.

Mobile phase: A mixture of a solution of sodium perchlorate (7 in 250) and acetonitrile (7:1).

Flow rate: Adjust so that the retention time of buformin is about 7 minutes.

System suitability—

System performance: When the procedure is run with 10 μL of the standard solution under the above operating conditions, buformin and the internal standard are eluted in this order with the resolution between these peaks being not less than 5.

System repeatability: When the test is repeated 6 times with 10 μL of the standard solution under the above operating conditions, the relative standard deviation of the ratio of the peak area of buformin to that of the internal standard is not more than 1.0%.

Containers and storage Containers—Well-closed containers.

Buformin Hydrochloride Tablets

ブホルミン塩酸塩錠

Buformin Hydrochloride Tablets contain not less than 95.0% and not more than 105.0% of the labeled amount of buformin hydrochloride (C₆H₁₅N₅.HCl: 193.68).

Method of preparation Prepare as directed under Tablets, with Buformin Hydrochloride.

Identification To a quantity of powdered Buformin Hydrochloride Tablets, equivalent to 1 g of Buformin Hydro-

chloride, add 100 mL of water, shake well, and then filter. To 4 mL of the filtrate add 1 mL of dilute sodium pentacyanonitrosylferrate (III)-potassium hexacyanoferrate (III) TS: the solution exhibits a red-brown color.

Uniformity of dosage units <6.02> Perform the Mass variation test, or the Content uniformity test according to the following method: it meets the requirement.

Take 1 tablet of Buformin Hydrochloride Tablets, add water to make exactly 200 mL, and then treat with ultrasonic waves for 5 minutes. Take 40 mL of this solution and centrifuge. Pipet V mL of the supernatant liquid equivalent to about 0.5 mg of buformin hydrochloride (C₆H₁₅N₅.HCl), add water to make exactly 100 mL, and use this solution as the sample solution. Separately, weigh accurately about 50 mg of buformin hydrochloride for assay, previously dried at 105°C for 3 hours, and dissolve in water to make exactly 200 mL. Pipet 2 mL of this solution, add water to make exactly 100 mL, and use this solution as the standard solution. Determine the absorbances, A_T and A_S , of the sample solution and standard solution at 233 nm as directed under Ultraviolet-visible Spectrophotometry <2.24>.

$$\begin{aligned} &\text{Amount (mg) of buformin hydrochloride (C}_6\text{H}_{15}\text{N}_5\text{.HCl)} \\ &= M_S \times A_T/A_S \times 2/V \end{aligned}$$

M_S : Amount (mg) of buformin hydrochloride for assay taken

Dissolution <6.10> When the test is performed at 50 revolutions per minute according to the Paddle method, using 900 mL of water as the dissolution medium, the dissolution rate in 15 minutes of Buformin Hydrochloride Tablets is not less than 80%.

Start the test with 1 tablet of Buformin Hydrochloride Tablets, withdraw not less than 20 mL of the medium at the specified minute after starting the test, and filter through a membrane filter with a pore size not exceeding 0.5 μm . Discard not less than 10 mL of the first filtrate, pipet V' mL of the subsequent filtrate, and add water to make exactly V' mL so that each mL contains about 5.6 μg of buformin hydrochloride (C₆H₁₅N₅.HCl), and use this solution as the sample solution. Separately, weigh accurately about 28 mg of buformin hydrochloride for assay, previously dried at 105°C for 3 hours, and dissolve in water to make exactly 100 mL. Pipet 2 mL of this solution, add water to make exactly 100 mL, and use this solution as the standard solution. Perform the test with the sample solution and standard solution as directed under Ultraviolet-visible Spectrophotometry <2.24>, and determine the absorbances, A_T and A_S , at 233 nm.

$$\begin{aligned} &\text{Dissolution rate (\%)} \text{ with respect to the labeled amount} \\ &\text{of buformin hydrochloride (C}_6\text{H}_{15}\text{N}_5\text{.HCl)} \\ &= M_S \times A_T/A_S \times V'/V \times 1/C \times 18 \end{aligned}$$

M_S : Amount (mg) of buformin hydrochloride for assay taken

C : Labeled amount (mg) of buformin hydrochloride (C₆H₁₅N₅.HCl) in 1 tablet

Assay Weigh accurately not less than 20 Buformin Hydrochloride Tablets, and powder. Weigh accurately a portion of the powder, equivalent to about 60 mg of buformin hydrochloride (C₆H₁₅N₅.HCl), add water to make exactly 200 mL, and treat with ultrasonic waves for 5 minutes. Take 40 mL of this solution, centrifuge, pipet 2 mL of the supernatant liquid, add water to make exactly 100 mL, and use this solution as the sample solution. Separately, weigh accurately about 60 mg of buformin hydrochloride for assay, previously dried at 105°C for 3 hours, and dissolve in water to

make exactly 200 mL. Pipet 2 mL of this solution, add water to make exactly 100 mL, and use this solution as the standard solution. Perform the test with the sample solution and standard solution as directed under Ultraviolet-visible Spectrophotometry <2.24>, and determine the absorbances, A_T and A_S , at 233 nm.

$$\text{Amount (mg) of bumetanide hydrochloride (C}_6\text{H}_5\text{N}_5\text{.HCl)} \\ = M_S \times A_T / A_S$$

M_S : Amount (mg) of bumetanide hydrochloride for assay taken

Containers and storage Containers—Well-closed containers.

Bumetanide

ブメタニド

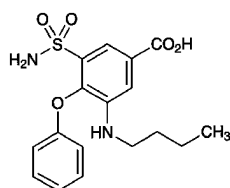

$\text{C}_{17}\text{H}_{20}\text{N}_2\text{O}_5\text{S}$: 364.42
3-Butylamino-4-phenoxy-5-sulfamoylbenzoic acid
[28395-03-1]

Bumetanide, when dried, contains not less than 98.5% of bumetanide ($\text{C}_{17}\text{H}_{20}\text{N}_2\text{O}_5\text{S}$).

Description Bumetanide occurs as white, crystals or crystalline powder.

It is freely soluble in pyridine, soluble in methanol and in ethanol (95), slightly soluble in diethyl ether, and practically insoluble in water.

It dissolves in potassium hydroxide TS.

It is gradually colored by light.

Identification (1) Dissolve 0.01 g of Bumetanide in 1 mL of pyridine, add 2 drops of copper (II) sulfate TS, shake, add 3 mL of water and 5 mL of chloroform, shake, and allow to stand: a light blue color develops in the chloroform layer.

(2) Dissolve 0.04 g of Bumetanide in 100 mL of phosphate buffer solution (pH 7.0) and dilute 10 mL of the solution with water to make 100 mL. Determine the absorption spectrum of the solution as directed under Ultraviolet-visible Spectrophotometry <2.24>, and compare the spectrum with the Reference Spectrum: both spectra exhibit similar intensities of absorption at the same wavelengths.

(3) Determine the infrared absorption spectrum of Bumetanide, previously dried, as directed in the potassium bromide disk method under Infrared Spectrophotometry <2.25>, and compare the spectrum with the Reference Spectrum: both spectra exhibit similar intensities of absorption at the same wave numbers.

Melting point <2.60> 232 – 237°C

Purity (1) Clarity and color of solution—Dissolve 50 mg of Bumetanide in 2 mL of a solution of potassium hydroxide (1 in 30) and 8 mL of water: the solution is clear, and is not more colored than the following control solution.

Control solution: Pipet 0.5 mL each of Cobalt (II) Chloride CS, Iron (III) Chloride CS and Copper (II) Sulfate CS,

mix them, and add diluted hydrochloric acid (1 in 40) to make exactly 100 mL.

(2) Chloride <1.03>—Mix well 0.5 g of Bumetanide with 0.7 g of potassium nitrate and 1.2 g of anhydrous sodium carbonate, transfer, in small portions, to a red-hot platinum crucible, and heat to red-hot until the reaction is complete. After cooling, to the residue add 14 mL of dilute sulfuric acid and 6 mL of water, boil for 5 minutes, filter, wash the residue with 10 mL of water, combine the filtrate and the washing, and add 6 mL of dilute nitric acid and water to make 50 mL. Perform the test using this solution as the test solution. Prepare the control solution with 0.30 mL of 0.01 mol/L hydrochloric acid VS (not more than 0.021%).

(3) Heavy metals <1.07>—Proceed with 2.0 g of Bumetanide according to Method 2, and perform the test. Prepare the control solution with 2.0 mL of Standard Lead Solution (not more than 10 ppm).

(4) Arsenic <1.11>—Prepare the test solution with 1.0 g of Bumetanide according to Method 3, and perform the test (not more than 2 ppm).

(5) Related substances—Conduct this procedure without exposure to light, using light-resistant vessels. Dissolve 0.10 g of Bumetanide in 10 mL of methanol, and use this solution as the sample solution. Pipet 1 mL of the sample solution, and add methanol to make exactly 100 mL. Pipet 2 mL of this solution, add methanol to make exactly 10 mL, and use this solution as the standard solution. Perform the test with these solutions as directed under Thin-layer Chromatography <2.03>. Spot 10 μL each of the sample solution and standard solution on a plate of silica gel with fluorescent indicator for thin-layer chromatography. Develop the plate with a mixture of chloroform, acetic acid (100), cyclohexane and methanol (32:4:4:1) to a distance of about 12 cm, and air-dry the plate. Examine under ultraviolet light (main wavelength: 254 nm): the spots other than the principal spot obtained from the sample solution are not more intense than the spot from the standard solution.

Loss on drying <2.41> Not more than 0.5% (1 g, 105°C, 2 hours).

Residue on ignition <2.44> Not more than 0.1% (1 g).

Assay Weigh accurately about 0.5 g of Bumetanide, previously dried, dissolve in 50 mL of ethanol (95), and titrate <2.50> with 0.1 mol/L sodium hydroxide VS (potentiometric titration). Perform a blank determination in the same manner, and make any necessary correction.

$$\text{Each mL of 0.1 mol/L sodium hydroxide VS} \\ = 36.44 \text{ mg of } \text{C}_{17}\text{H}_{20}\text{N}_2\text{O}_5\text{S}$$

Containers and storage Containers—Tight containers.

Storage—Light-resistant.

Bunazosin Hydrochloride

ブナゾシン塩酸塩

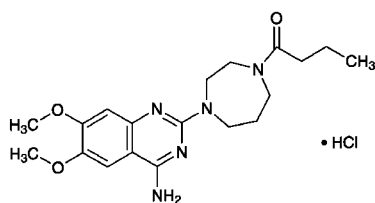

$C_{19}H_{27}N_5O_3 \cdot HCl$: 409.91

4-Amino-2-(4-butanoyl-1,4-diazepan-1-yl)-6,7-dimethoxyquinazoline monohydrochloride
[52712-76-2]

Bunazosin Hydrochloride, when dried, contains not less than 98.0% of bunazosin hydrochloride ($C_{19}H_{27}N_5O_3 \cdot HCl$).

Description Bunazosin Hydrochloride occurs as a white crystalline powder.

It is very soluble in formic acid, slightly soluble in water and in methanol, very slightly soluble in ethanol (99.5), and practically insoluble in diethyl ether.

Melting point: about 273°C (with decomposition).

Identification (1) Dissolve 0.1 g of Bunazosin Hydrochloride in 10 mL of 0.2 mol/L hydrochloric acid TS, and boil for 3 minutes over a flame: butyric acid like odor is perceptible.

(2) Determine the infrared absorption spectrum of Bunazosin Hydrochloride, previously dried, as directed in the potassium bromide disk method under Infrared Spectrophotometry <2.25>, and compare the spectrum with the Reference Spectrum: both spectra exhibit similar intensities of absorption at the same wave numbers.

(3) A solution of Bunazosin Hydrochloride (1 in 100) responds to Qualitative Tests <1.09> for chloride.

Purity (1) Heavy metals <1.07>—Proceed with 1.0 g of Bunazosin Hydrochloride according to Method 4, and perform the test. Prepare the control solution with 2.0 mL of Standard Lead Solution (not more than 20 ppm).

(2) Related substances—Dissolve 0.05 g of Bunazosin Hydrochloride in 50 mL of the mobile phase, and use this solution as the sample solution. To exactly 1 mL of the sample solution add the mobile phase to make exactly 200 mL, and use this solution as the standard solution. Perform the test with exactly 10 μL each of the sample solution and standard solution as directed under Liquid Chromatography <2.01> according to the following conditions. Determine each peak area of both solutions by the automatic integration method: the total area of the peaks other than bunazosin obtained from the sample solution is not larger than the peak area of bunazosin from the standard solution.

Operating conditions—

Detector: An ultraviolet absorption photometer (wavelength: 254 nm).

Column: A stainless steel column about 4 mm in inside diameter and about 15 cm in length, packed with octadecylsilylaned silica gel for liquid chromatography (5 μm in particle diameter).

Column temperature: A constant temperature of about 30°C.

Mobile phase: Dissolve 1.44 g of sodium lauryl sulfate in a suitable amount of water, add 10 mL of acetic acid (100),

500 mL of acetonitrile and water to make 1000 mL.

Flow rate: Adjust so that the retention time of bunazosin is about 5 minutes.

Selection of column: Proceed with 20 μL of a mixture of the standard solution and a solution of procaine hydrochloride in the mobile phase (1 in 20,000) (1:1) under the above operating conditions, and calculate the resolution. Use a column giving elution of procaine and bunazosin in this order with the resolution between these peaks being not less than 3.0.

Detection sensitivity: Adjust the detection sensitivity so that the peak height of bunazosin obtained from 20 μL of the standard solution is 20 to 60% of the full-scale.

Time span of measurement: About 6 times of the retention time of bunazosin.

Loss on drying <2.41> Not more than 0.5% (1 g, 105°C, 2 hours).

Residue on ignition <2.44> Not more than 0.1% (1 g).

Assay Weigh accurately about 0.3 g of Bunazosin Hydrochloride, previously dried, dissolve in 6 mL of formic acid, add exactly 15 mL of 0.1 mol/L perchloric acid, and heat for 20 minutes on a water bath. After cooling, add 20 mL of acetic acid (100), and titrate <2.50> the excess perchloric acid with 0.1 mol/L sodium acetate VS (potentiometric titration). Perform a blank determination in the same manner.

Each mL of 0.1 mol/L perchloric acid VS
= 40.99 mg of $C_{19}H_{27}N_5O_3 \cdot HCl$

Containers and storage Containers—Well-closed containers.

Storage—Light-resistant.

Bupivacaine Hydrochloride Hydrate

ブピバカイン塩酸塩水和物

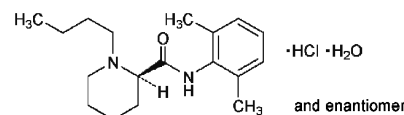

$C_{18}H_{28}N_2O \cdot HCl \cdot H_2O$: 342.90

(2*RS*)-1-Butyl-*N*-(2,6-dimethylphenyl)piperidine-2-carboxamide monohydrochloride monohydrate
[14252-80-3]

Bupivacaine Hydrochloride Hydrate contains not less than 98.5% and not more than 101.0% of bupivacaine hydrochloride ($C_{18}H_{28}N_2O \cdot HCl$: 324.89), calculated on the anhydrous basis.

Description Bupivacaine Hydrochloride Hydrate occurs as a white crystalline powder.

It is freely soluble in acetic acid (100), and soluble in water, in methanol and in ethanol (99.5).

It dissolves in 0.01 mol/L hydrochloric acid TS.

A solution of 0.5 g of Bupivacaine Hydrochloride Hydrate in 50 mL of a mixture of ethanol (99.5), water and 5 mol/L sodium hydroxide TS (34:15:1) shows no optical rotation.

Melting point: about 252°C (with decomposition).

Identification (1) Determine the absorption spectrum of a solution of Bupivacaine Hydrochloride Hydrate in 0.01 mol/L hydrochloric acid TS (1 in 2000) as directed under Ul-

traviolet-visible Spectrophotometry <2.24>, and compare the spectrum with the Reference Spectrum: both spectra exhibit similar intensities of absorption at the same wavelengths.

(2) Determine the infrared absorption spectrum of Bupivacaine Hydrochloride Hydrate as directed in the potassium chloride disk method under Infrared Spectrophotometry <2.25>, and compare the spectrum with the Reference Spectrum: both spectra exhibit similar intensities of absorption at the same wave numbers.

(3) A solution of Bupivacaine Hydrochloride Hydrate (1 in 50) responds to Qualitative Tests <1.09> for chloride.

pH <2.54> The pH of a solution obtained by dissolving 1.0 g of Bupivacaine Hydrochloride Hydrate in 100 mL of freshly boiled and cooled water is between 4.5 to 6.0.

Purity (1) Clarity and color of solution—Dissolve 1.0 g of Bupivacaine Hydrochloride Hydrate in 50 mL of water: the solution is clear and colorless.

(2) Heavy metals <1.07>—Proceed with 1.0 g of Bupivacaine Hydrochloride Hydrate according to Method 1, and perform the test. Prepare the control solution with 2.0 mL of Standard Lead Solution (not more than 20 ppm).

(3) 2,6-Dimethylaniline—Dissolve exactly 0.50 g of Bupivacaine Hydrochloride Hydrate in 10 mL of methanol. To 2 mL of this solution add 1 mL of a freshly prepared solution of 4-dimethylaminobenzaldehyde in methanol (1 in 100) and 2 mL of acetic acid (100), and allow to stand for 10 minutes: the color of the solution is not more colored than the following control solution.

Control solution: Prepare by proceeding in the same manner as above, using 2 mL of a solution of 2,6-dimethylaniline in methanol (1 in 200,000).

(4) Related substances—Dissolve 50 mg of Bupivacaine Hydrochloride Hydrate in 2.5 mL of water, add 2.5 mL of 2 mol/L sodium hydroxide TS and 5 mL of the internal standard solution, shake, collect the lower layer, filter, and use the filtrate as the sample solution. Pipet 1 mL of the sample solution, and add the internal standard solution to make exactly 100 mL. Pipet 1 mL of this solution, add the internal standard solution to make exactly 10 mL, and use this solution as the standard solution. Perform the test with 1 μ L each of the sample solution and standard solution as directed under Gas Chromatography <2.02> according to the following conditions, and determine each peak area by the automatic integration method: the ratio of the area of the peak other than bupivacaine to the peak area of the internal standard obtained from the sample solution is not larger than the ratio of the peak area of bupivacaine to that of the internal standard from the standard solution.

Internal standard solution—A solution of methyl behenate in dichloromethane (1 in 20,000).

Operating conditions—

Detector: A hydrogen flame-ionization detector.

Column: A quartz tube 0.32 mm in inside diameter and 30 m in length, coated the inside surface with 5% diphenyl-95% dimethylpolysiloxane for gas chromatography 0.25 μ m in thickness.

Column temperature: Rise the temperature from 180°C to 230°C at the rate of 5°C per minute, and maintain at 230°C for 5 minutes.

Injection port temperature: A constant temperature of about 250°C.

Detector temperature: A constant temperature of about 250°C.

Carrier gas: Helium.

Flow rate: Adjust so that the retention time of bupivacaine is about 10 minutes.

Split ratio: 1:12.

Time span of measurement: About 1.5 times as long as the retention time of bupivacaine.

System suitability—

System performance: To 1 mL of the sample solution add the internal standard solution to make 100 mL, and use this solution as the solution for system suitability test. When the procedure is run with 1 μ L of the solution for system suitability test under the above operating conditions, bupivacaine and the internal standard are eluted in this order with the resolution between these peaks being not less than 20.

System repeatability: When the test is repeated 6 times with 1 μ L of the solution for system suitability test under the above operating conditions, the relative standard deviation of the ratio of the peak area of bupivacaine to that of the internal standard is not more than 2.0%.

Water <2.48> 4.0–6.0% (0.25 g, volumetric titration, direct titration).

Residue on ignition <2.44> Not more than 0.1% (1 g).

Assay Weigh accurately about 0.5 g of Bupivacaine Hydrochloride Hydrate, dissolve in 20 mL of acetic acid (100), add 50 mL of acetic anhydride, and titrate <2.50> with 0.1 mol/L perchloric acid VS (potentiometric titration). Perform a blank determination in the same manner, and make any necessary correction.

Each mL of 0.1 mol/L perchloric acid VS
= 32.49 mg of C₁₈H₂₈N₂O.HCl

Containers and storage Containers—Tight containers.

Bupranolol Hydrochloride

ブプラノロール塩酸塩

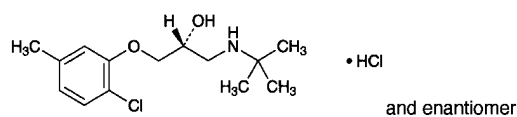

C₁₄H₂₂ClNO₂.HCl: 308.24

(2*RS*)-3-(2-Chloro-5-methylphenoxy)-1-(1,1-dimethylethyl)aminopropan-2-ol monohydrochloride
[15148-80-8]

Bupranolol Hydrochloride, when dried, contains not less than 98.0% of bupranolol hydrochloride (C₁₄H₂₂ClNO₂.HCl).

Description Bupranolol Hydrochloride occurs as a white crystalline powder.

It is sparingly soluble in methanol, slightly soluble in water, in ethanol (95) and in acetic acid (100), very slightly soluble in acetic anhydride, and practically insoluble in diethyl ether.

The pH of a solution of 1.0 g of Bupranolol Hydrochloride in 1000 mL of water is between 5.2 and 6.2.

Identification (1) Take 0.01 g of Bupranolol Hydrochloride in a test tube, mix with 25 mg of potassium iodide and 25 mg of oxalic acid dihydrate, cover the mouth of the test tube with filter paper moistened with a solution of 2,6-dibromo-*N*-chloro-1,4-benzoquinone monoimine in ethanol (95) (1 in 100), and heat gently for several minutes. Expose the filter paper to ammonia gas: the filter paper acquires a blue color.

(2) Determine the absorption spectrum of a solution of

Bupranolol Hydrochloride in 0.1 mol/L hydrochloric acid TS (1 in 10,000) as directed under Ultraviolet-visible Spectrophotometry <2.24>, and compare the spectrum with the Reference Spectrum: both spectra exhibit similar intensities of absorption at the same wavelengths.

(3) Determine the infrared absorption spectrum of Bupranolol Hydrochloride, previously dried, as directed in the potassium chloride disk method under Infrared Spectrophotometry <2.25>, and compare the spectrum with the Reference Spectrum: both spectra exhibit similar intensities of absorption at the same wave numbers.

(4) A solution of Bupranolol Hydrochloride (1 in 200) responds to Qualitative Tests <1.09> for chloride.

Absorbance <2.24> $E_{1\text{cm}}^{1\%}$ (275 nm): 57 – 60 (after drying, 50 mg, 0.1 mol/L hydrochloric acid TS, 500 mL).

Melting point <2.60> 223 – 226°C

Purity (1) Clarity and color of solution—Dissolve 0.10 g of Bupranolol Hydrochloride in 15 mL of water: the solution is clear and colorless.

(2) Acidity—Dissolve 0.10 g of Bupranolol Hydrochloride in 15 mL of freshly boiled and cooled water, and add 1 drop of methyl red TS: a light red color develops. To this solution add 0.05 mL of 0.01 mol/L sodium hydroxide VS: the color changes to yellow.

(3) Sulfate <1.14>—Perform the test with 0.10 g of Bupranolol Hydrochloride. Prepare the control solution with 0.35 mL of 0.005 mol/L sulfuric acid VS (not more than 0.168%).

(4) Heavy metals <1.07>—Proceed with 1.0 g of Bupranolol Hydrochloride according to Method 4, and perform the test. Prepare the control solution with 2.0 mL of Standard Lead Solution (not more than 20 ppm).

(5) Arsenic <1.11>—Prepare the test solution with 1.0 g of Bupranolol Hydrochloride according to Method 3, and perform the test (not more than 2 ppm).

(6) Related substances—Dissolve 0.30 g of Bupranolol Hydrochloride in 10 mL of methanol, and use this solution as the sample solution. Pipet 1 mL of the sample solution, add methanol to make exactly 100 mL, and use this solution as the standard solution. Perform the test with these solutions as directed under Thin-layer Chromatography <2.03>. Spot 10 μL each of the sample solution and standard solution on a plate of polyamide with fluorescent indicator for thin-layer chromatography. Develop the plate with a mixture of methanol, ammonia solution (28) and water (16:4:1) to a distance of about 10 cm, and air-dry the plate. Examine under ultraviolet light (main wavelength: 254 nm): the spots other than the principal spot obtained from the sample solution are not more intense than the spot from the standard solution.

Loss on drying <2.41> Not more than 0.5% (0.5 g, 105°C, 4 hours).

Residue on ignition <2.44> Not more than 0.1% (1 g).

Assay Weigh accurately about 0.18 g of Bupranolol Hydrochloride, previously dried, dissolve in 60 mL of a mixture of acetic anhydride and acetic acid (100) (2:1) by warming, cool, and titrate <2.50> with 0.1 mol/L perchloric acid VS (potentiometric titration). Perform a blank determination in the same manner, and make any necessary correction.

Each mL of 0.1 mol/L perchloric acid VS
= 30.82 mg of $\text{C}_{14}\text{H}_{22}\text{ClNO}_2 \cdot \text{HCl}$

Containers and storage Containers—Well-closed containers.

Buprenorphine Hydrochloride

ブプレノルフィン塩酸塩

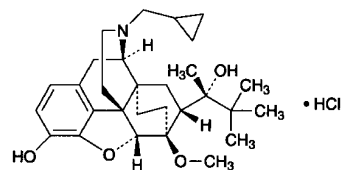

$\text{C}_{29}\text{H}_{41}\text{NO}_4 \cdot \text{HCl}$: 504.10

(2*S*)-2-[(5*R*,6*R*,7*R*,14*S*)-17-(Cyclopropylmethyl)-4,5-epoxy-3-hydroxy-6-methoxy-6,14-ethanomorphinan-7-yl]-3,3-dimethylbutan-2-ol monohydrochloride
[53152-21-9]

Buprenorphine Hydrochloride, when dried, contains not less than 98.5% and not more than 101.0% of buprenorphine hydrochloride ($\text{C}_{29}\text{H}_{41}\text{NO}_4 \cdot \text{HCl}$).

Description Buprenorphine Hydrochloride occurs as white to yellowish white, crystals or a crystalline powder.

It is freely soluble in methanol and in acetic acid (100), and sparingly soluble in water and in ethanol (99.5).

Melting point: about 268°C (with decomposition).

Identification (1) Determine the absorption spectrum of a solution of Buprenorphine Hydrochloride (1 in 5000) as directed under Ultraviolet-visible Spectrophotometry <2.24>, and compare the spectrum with the Reference Spectrum: both spectra exhibit similar intensities of absorption at the same wavelengths.

(2) Determine the infrared absorption spectrum of Buprenorphine Hydrochloride as directed in the potassium chloride disk method under Infrared Spectrophotometry <2.25>, and compare the spectrum with the Reference Spectrum: both spectra exhibit similar intensities of absorption at the same wave numbers.

(3) A solution of Buprenorphine Hydrochloride (1 in 100) responds to Qualitative Tests <1.09> for chloride.

Optical rotation <2.49> $[\alpha]_D^{20}$: -92 – -98° (after drying, 0.4 g, methanol, 20 mL, 100 mm).

pH <2.54> The pH of a solution prepared by dissolving 1.0 g of Buprenorphine Hydrochloride in 200 mL of water is between 4.0 and 6.0.

Purity (1) Clarity and color of solution—A solution obtained by dissolving 0.1 g of Buprenorphine Hydrochloride in 10 mL of water is clear and colorless.

(2) Heavy metals <1.07>—Proceed with 1.0 g of Buprenorphine Hydrochloride according to Method 4, and perform the test. Prepare the control solution with 1.0 mL of Standard Lead Solution (not more than 10 ppm).

(3) Related substances—Dissolve 0.10 g of Buprenorphine Hydrochloride in 20 mL of the mobile phase, and use this solution as the sample solution. Pipet 1 mL of the sample solution, add the mobile phase to make exactly 100 mL, and use this solution as the standard solution. Perform the test with exactly 20 μL each of the sample solution and standard solution as directed under Liquid Chromatography <2.01> according to the following conditions. Determine each peak area of both solutions by the automatic integration method: the area of each peak other than buprenorphine obtained from the sample solution is not larger than 1/4 times the peak area of buprenorphine obtained from the standard solution. Furthermore, the total area of the peaks other than

buprenorphine from the sample solution is not larger than 13/20 times the peak area of buprenorphine from the standard solution.

Operating conditions—

Detector: An ultraviolet absorption photometer (wavelength: 288 nm).

Column: A stainless steel column 4.6 mm in inside diameter and 25 cm in length, packed with octadecylsilanized silica gel for liquid chromatography (5 μm in particle diameter).

Column temperature: A constant temperature of about 40°C.

Mobile phase: A mixture of methanol, ammonium acetate solution (1 in 100), and acetic acid (100) (6000:1000:1).

Flow rate: Adjust so that the retention time of buprenorphine is about 17 minutes.

Time span of measurement: About 2.5 times as long as the retention time of buprenorphine, beginning after the solvent peak.

System suitability—

Test for required detectability: Pipet 5 mL of the standard solution, and add the mobile phase to make exactly 50 mL. Confirm that the peak area of buprenorphine obtained with 20 μL of this solution is equivalent to 7 to 13% of that with 20 μL of the standard solution.

System performance: When the procedure is run with 20 μL of the standard solution under the above operating conditions, the number of theoretical plates and the symmetry factor of the peak of buprenorphine are not less than 6500 and not more than 1.2, respectively.

System repeatability: When the test is repeated 6 times with 20 μL of the standard solution under the above operating conditions, the relative standard deviation of the peak area of buprenorphine is not more than 2.0%.

Loss on drying <2.41> Not more than 1.0% (1 g, 115°C, 3 hours).

Residue on ignition <2.44> Not more than 0.1% (1 g).

Assay Weigh accurately about 0.5 g of Buprenorphine Hydrochloride, previously dried, dissolve in 5 mL of acetic acid (100), add 50 mL of acetic anhydride, and titrate <2.50> with 0.1 mol/L perchloric acid VS (potentiometric titration). Perform a blank determination in the same manner, and make any necessary correction.

Each mL of 0.1 mol/L perchloric acid VS
= 50.41 mg of C₂₉H₄₁NO₄·HCl

Containers and storage Containers—Well-closed containers.

Busulfan

ブスルファン

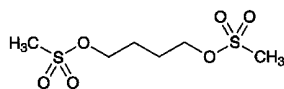

C₆H₁₄O₆S₂: 246.30

Tetramethylenedimethanesulfonate
[55-98-1]

Busulfan contains not less than 98.5% of busulfan (C₆H₁₄O₆S₂), calculated on the dried basis.

Description Busulfan occurs as a white crystalline powder.

It is slightly soluble in diethyl ether, very slightly soluble in ethanol (95), and practically insoluble in water.

Identification (1) To 0.1 g of Busulfan add 10 mL of water and 5 mL of sodium hydroxide TS, dissolve by heating, and use this solution as the sample solution.

(i) To 7 mL of the sample solution add 1 drop of potassium permanganate TS: the red-purple color of potassium permanganate TS changes from blue-purple through blue to green.

(ii) Acidify 7 mL of the sample solution with dilute sulfuric acid, and add 1 drop of potassium permanganate TS: the color of potassium permanganate TS remains.

(2) Determine the infrared absorption spectrum of Busulfan, previously dried, as directed in the potassium bromide disk method under Infrared Spectrophotometry <2.25>, and compare the spectrum with the Reference Spectrum: both spectra exhibit similar intensities of absorption at the same wave numbers.

Melting point <2.60> 115 – 118°C

Purity (1) Sulfate <1.14>—To 1.0 g of Busulfan add 40 mL of water, and dissolve by heating. Cool in ice for 15 minutes, and filter. Wash the residue with 5 mL of water, combine the washings with the filtrate, and add 1 mL of dilute hydrochloric acid and water to make 50 mL. Perform the test using this solution as the test solution. Prepare the control solution with 0.40 mL of 0.005 mol/L sulfuric acid VS (not more than 0.019%).

(2) Heavy metals <1.07>—Proceed with 1.0 g of Busulfan according to Method 2, and perform the test. Prepare the control solution with 2.0 mL of Standard Lead Solution (not more than 20 ppm).

Loss on drying <2.41> Not more than 2.0% (1 g, in vacuum, phosphorus (V) oxide, 60°C, 4 hours).

Residue on ignition <2.44> Not more than 0.1% (1 g).

Assay Weigh accurately about 0.2 g of Busulfan, add 40 mL of water, and boil gently under a reflux condenser for 30 minutes. Cool, and titrate <2.50> with 0.1 mol/L sodium hydroxide VS (indicator: 3 drops of phenolphthalein TS).

Each mL of 0.1 mol/L sodium hydroxide VS
= 12.32 mg of C₆H₁₄O₆S₂

Containers and storage Containers—Well-closed containers.

Storage—Light-resistant.

Butenafine Hydrochloride

ブテナフィン塩酸塩

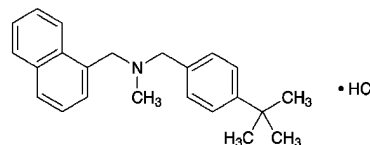

C₂₃H₂₇N·HCl: 353.93

N-[4-(1,1-Dimethylethyl)benzyl]-*N*-methyl-1-(naphthalen-1-yl)methylamine monohydrochloride
[101827-46-7]

Butenafine Hydrochloride, when dried, contains not less than 99.0% and not more than 101.0% of butenafine hydrochloride (C₂₃H₂₇N·HCl).

Description Butenafine Hydrochloride occurs as white, crystals or crystalline powder.

It is very soluble in formic acid, freely soluble in methanol and in ethanol (99.5), and slightly soluble in water.

The pH of a solution dissolved 0.20 g of Butenafine Hydrochloride in 100 mL of water by warming and cooled is 3.0 to 4.0.

Melting point: about 214°C (with decomposition).

Identification (1) Determine the absorption spectrum of a solution of Butenafine Hydrochloride in methanol (1 in 40,000) as directed under Ultraviolet-visible Spectrophotometry <2.24>, and compare the spectrum with the Reference Spectrum: both spectra exhibit similar intensities of absorption at the same wavelengths.

(2) Determine the infrared absorption spectrum of Butenafine Hydrochloride, previously dried, as directed in the potassium chloride disk method under Infrared Spectrophotometry <2.25>, and compare the spectrum with the Reference Spectrum: both spectra exhibit similar intensities of absorption at the same wave numbers.

(3) A solution of Butenafine Hydrochloride in dilute ethanol (1 in 200) responds to Qualitative Tests <1.09> (1) for chloride.

Purity (1) Heavy metals <1.07>—Dissolve 2.0 g of Butenafine Hydrochloride in 20 mL of ethanol (99.5), add 2 mL of dilute acetic acid and ethanol (99.5) to make 50 mL, and perform the test using this solution as the test solution. The control solution: To 2.0 mL of Standard Lead Solution add 2 mL of dilute acetic acid, and add ethanol (99.5) to make 50 mL (not more than 10 ppm).

(2) Related substances—Dissolve 30 mg of Butenafine Hydrochloride in 50 mL of a mixture of water and acetonitrile for liquid chromatography (3:2), and use this solution as the sample solution. Pipet 1 mL of the sample solution, add a mixture of water and acetonitrile for liquid chromatography (3:2) to make exactly 50 mL. Pipet 1 mL of this solution, add a mixture of water and acetonitrile for liquid chromatography (3:2) to make exactly 20 mL, and use this solution as the standard solution. Perform the test with exactly 10 μL each of the sample solution and standard solution as directed under Liquid Chromatography <2.01> according to the following conditions, and determine each peak area of both solutions by the automatic integration method: the area of the peak, having the relative retention time of about 0.16 to butenafine, obtained from the sample solution is not larger than 3/10 times the peak area of butenafine from the standard solution, and the area of the peak other than butenafine and the peak mentioned above from the sample solution is not larger than the peak area of butenafine from the standard solution.

Operating conditions—

Detector: An ultraviolet absorption photometer (wavelength: 217 nm).

Column: A stainless steel column 3.0 mm in inside diameter and 15 cm in length, packed with octadecylsilanized silica gel for liquid chromatography (3 μm in particle diameter).

Column temperature: A constant temperature of about 40°C.

Mobile phase A: Diluted 0.5 mol/L ammonium acetate TS (1 in 1000).

Mobile phase B: Acetonitrile for liquid chromatography.

Flowing of mobile phase: Control the gradient by mixing the mobile phases A and B as directed in the following table.

Time after injection of sample (min)	Mobile phase A (vol%)	Mobile phase B (vol%)
0 - 10	60 → 20	40 → 80
10 - 60	20	80

Flow rate: 0.4 mL per minute.

Time span of measurement: For 60 minutes after injection, beginning after the solvent peak.

System suitability—

Test for required detectability: Pipet 2 mL of the standard solution, and add a mixture of water and acetonitrile for liquid chromatography (3:2) to make exactly 10 mL. Confirm that the peak area of butenafine obtained with 10 μL of this solution is equivalent to 14 to 26% of that with 10 μL of the standard solution.

System performance: When the procedure is run with 10 μL of the standard solution under the above operating conditions, the number of theoretical plates and the symmetry factor of the peak of butenafine are not less than 20,000 and 0.9 to 1.2, respectively.

System repeatability: When the test is repeated 6 times with 10 μL of the standard solution under the above operating conditions, the relative standard deviation of the peak area of butenafine is not more than 2.0%.

Loss on drying <2.41> Not more than 0.1% (1 g, in vacuum, phosphorus (V) oxide, 60°C, 3 hours).

Residue on ignition <2.44> Not more than 0.1% (1 g).

Assay Weigh accurately about 0.3 g of Butenafine Hydrochloride, previously dried, dissolve in 5 mL of formic acid, add 80 mL of acetic anhydride, and titrate <2.50> with 0.1 mol/L perchloric acid VS (potentiometric titration). Perform a blank determination in the same manner, and make any necessary correction.

Each mL of 0.1 mol/L perchloric acid VS
= 35.39 mg of C₂₃H₂₇N.HCl

Containers and storage Containers—Tight containers.

Butenafine Hydrochloride Cream

ブテナフィン塩酸塩クリーム

Butenafine Hydrochloride Cream contains not less than 95.0% and not more than 105.0% of the labeled amount of butenafine hydrochloride (C₂₃H₂₇N.HCl: 353.93).

Method of preparation Prepare as directed under Creams, with Butenafine Hydrochloride.

Identification To an amount of Butenafine Hydrochloride Cream, equivalent to 20 mg of Butenafine Hydrochloride, add 20 mL of acetonitrile, and warm on a water bath to melt the bases. Shake thoroughly, add an appropriate amount of sodium chloride, and allow to stand for 30 minutes in an ice cold water keeping not exceeding 0°C to separate out the bases. Centrifuge, collect the supernatant liquid, add an appropriate amount of sodium chloride to the liquid, allow to stand for 1 hour in an ice cold water keeping not exceeding 0°C, and filter while cooling. To 1 mL of the filtrate add methanol to make 20 mL, and determine the absorption spectrum of this solution as directed under Ultraviolet-visible Spectrophotometry <2.24>: it exhibits maxima be-

tween 272 nm and 276 nm, between 281 nm and 285 nm, between 311 nm and 315 nm, and between 316 nm and 320 nm, and a shoulder between 289 nm and 299 nm.

Assay Weigh accurately a quantity of Butenafine Hydrochloride Cream, equivalent to about 5 mg of butenafine hydrochloride ($C_{23}H_{27}N.HCl$), add 20 mL of methanol, and add exactly 10 mL of the internal standard solution. Warm this in a water bath for 5 minutes, and shake vigorously for 20 minutes. Then, cool in an ice bath for 15 minutes, centrifuge, and filter the supernatant liquid with a membrane filter with a pore size not exceeding $0.45 \mu m$. Discard the first 5 mL of the filtrate, and use the subsequent filtrate as the sample solution. Separately, weigh accurately about 25 mg of butenafine hydrochloride for assay, previously dried in vacuum at $60^\circ C$ for 3 hours using phosphorus (V) oxide as desiccant, and dissolve in methanol to make exactly 100 mL. Pipet 20 mL of this solution, add exactly 10 mL of the internal standard solution, and use this solution as the standard solution. Perform the test with $5 \mu L$ each of the sample solution and standard solution as directed under Liquid Chromatography <2.01> according to the following conditions, and calculate the ratios, Q_T and Q_S , of the peak area of butenafine to that of the internal standard.

$$\text{Amount (mg) of butenafine hydrochloride (C}_{23}\text{H}_{27}\text{N.HCl)} \\ = M_S \times Q_T / Q_S \times 1/5$$

M_S : Amount (mg) of butenafine hydrochloride for assay taken

Internal standard solution—A solution of diphenyl in methanol (3 in 2000).

Operating conditions—

Detector: An ultraviolet absorption photometer (wavelength: 282 nm).

Column: A stainless steel column 3.0 mm in inside diameter and 5 cm in length, packed with octylsilylated silica gel for liquid chromatography ($3 \mu m$ in particle diameter).

Column temperature: A constant temperature of about $40^\circ C$.

Mobile phase: A mixture of acetonitrile and diluted 0.5 mol/L ammonium acetate TS (1 in 500) (4:1).

Flow rate: Adjust so that the retention time of butenafine is about 2.5 minutes.

System suitability—

System performance: When the procedure is run with $5 \mu L$ of the standard solution under the above operating conditions, the internal standard and butenafine are eluted in this order with the resolution between these peaks being not less than 6.

System repeatability: When the test is repeated 6 times with $5 \mu L$ of the standard solution under the above operating conditions, the relative standard deviation of the ratio of the peak area of butenafine to that of the internal standard is not more than 1.0%.

Containers and storage Containers—Tight containers.

Storage—Light-resistant.

Butenafine Hydrochloride Solution

ブテナフィン塩酸塩液

Butenafine Hydrochloride Solution is a liquid for external use.

It contains not less than 95.0% and not more than 105.0% of the labeled amount of butenafine hydrochloride ($C_{23}H_{27}N.HCl$: 353.93).

Method of preparation Prepare as directed under Liquids and Solutions for Cutaneous Application, with Butenafine Hydrochloride.

Identification To an amount of Butenafine Hydrochloride Solution, equivalent to 10 mg of Butenafine Hydrochloride, add methanol to make 200 mL, and determine the absorption spectrum of this solution as directed under Ultraviolet-visible Spectrophotometry <2.24>: it exhibits maxima between 272 nm and 276 nm, between 281 nm and 285 nm, between 311 nm and 315 nm, and between 316 nm and 320 nm, and a shoulder between 289 nm and 299 nm.

Assay To an exact volume of Butenafine Hydrochloride Solution, equivalent to about 20 mg of butenafine hydrochloride ($C_{23}H_{27}N.HCl$), add methanol to make exactly 50 mL. Pipet 5 mL of this solution, add exactly 4 mL of the internal standard solution, then add methanol to make 25 mL, and use this solution as the sample solution. Separately, weigh accurately about 20 mg of butenafine hydrochloride for assay, previously dried in vacuum at $60^\circ C$ for 3 hours using phosphorus (V) oxide as desiccant, and dissolve in methanol to make exactly 50 mL. Pipet 5 mL of this solution, add exactly 4 mL of the internal standard solution, then add methanol to make 25 mL, and use this solution as the standard solution. Perform the test with $5 \mu L$ each of the sample solution and standard solution as directed under Liquid Chromatography <2.01> according to the following conditions, and calculate the ratios, Q_T and Q_S , of the peak area of butenafine to that of the internal standard.

$$\text{Amount (mg) of butenafine hydrochloride (C}_{23}\text{H}_{27}\text{N.HCl)} \\ = M_S \times Q_T / Q_S$$

M_S : Amount (mg) of butenafine hydrochloride for assay taken

Internal standard solution—A solution of diphenyl in methanol (3 in 2000).

Operating conditions—

Detector: An ultraviolet absorption photometer (wavelength: 282 nm).

Column: A stainless steel column 3.0 mm in inside diameter and 5 cm in length, packed with octylsilylated silica gel for liquid chromatography ($3 \mu m$ in particle diameter).

Column temperature: A constant temperature of about $40^\circ C$.

Mobile phase: A mixture of acetonitrile and diluted 0.5 mol/L ammonium acetate TS (1 in 500) (4:1).

Flow rate: Adjust so that the retention time of butenafine is about 2.5 minutes.

System suitability—

System performance: When the procedure is run with $5 \mu L$ of the standard solution under the above operating conditions, the internal standard and butenafine are eluted in this order with the resolution between these peaks being not less than 6.

System repeatability: When the test is repeated 6 times

with 5 μL of the standard solution under the above operating conditions, the relative standard deviation of the ratio of the peak area of butenafine to that of the internal standard is not more than 1.0%.

Containers and storage Containers—Tight containers.
Storage—Light-resistant.

Butenafine Hydrochloride Spray

ブテナフィン塩酸塩スプレー

Butenafine Hydrochloride Spray contains not less than 95.0% and not more than 105.0% of the labeled amount of butenafine hydrochloride ($\text{C}_{23}\text{H}_{27}\text{N}\cdot\text{HCl}$: 353.93).

Method of preparation Prepare as directed under Pump Sprays for Cutaneous Application, with Butenafine Hydrochloride.

Identification To an amount of Butenafine Hydrochloride Spray, equivalent to 10 mg of Butenafine Hydrochloride, add methanol to make 200 mL, and determine the absorption spectrum of this solution as directed under Ultraviolet-visible Spectrophotometry <2.24>: it exhibits maxima between 272 nm and 276 nm, between 281 nm and 285 nm, between 311 nm and 315 nm, and between 316 nm and 320 nm, and a shoulder between 289 nm and 299 nm.

Assay To an exact volume of Butenafine Hydrochloride Spray, equivalent to about 20 mg of butenafine hydrochloride ($\text{C}_{23}\text{H}_{27}\text{N}\cdot\text{HCl}$), add methanol to make exactly 50 mL. Pipet 5 mL of this solution, add exactly 4 mL of the internal standard solution, then add methanol to make 25 mL, and use this solution as the sample solution. Separately, weigh accurately about 20 mg of butenafine hydrochloride for assay, previously dried in vacuum at 60°C for 3 hours using phosphorus (V) oxide as desiccant, and dissolve in methanol to make exactly 50 mL. Pipet 5 mL of this solution, add exactly 4 mL of the internal standard solution, then add methanol to make 25 mL, and use this solution as the standard solution. Perform the test with 5 μL each of the sample solution and standard solution as directed under Liquid Chromatography <2.01> according to the following conditions, and calculate the ratios, Q_T and Q_S , of the peak area of butenafine to that of the internal standard.

$$\text{Amount (mg) of butenafine hydrochloride (C}_{23}\text{H}_{27}\text{N}\cdot\text{HCl}) \\ = M_S \times Q_T / Q_S$$

M_S : Amount (mg) of butenafine hydrochloride for assay taken

Internal standard solution—A solution of diphenyl in methanol (3 in 2000).

Operating conditions—

Detector: An ultraviolet absorption photometer (wavelength: 282 nm).

Column: A stainless steel column 3.0 mm in inside diameter and 5 cm in length, packed with octylsilylated silica gel for liquid chromatography (3 μm in particle diameter).

Column temperature: A constant temperature of about 40°C.

Mobile phase: A mixture of acetonitrile and diluted 0.5 mol/L ammonium acetate TS (1 in 500) (4:1).

Flow rate: Adjust so that the retention time of butenafine is about 2.5 minutes.

System suitability—

System performance: When the procedure is run with 5 μL of the standard solution under the above operating conditions, the internal standard and butenafine are eluted in this order with the resolution between these peaks being not less than 6.

System repeatability: When the test is repeated 6 times with 5 μL of the standard solution under the above operating conditions, the relative standard deviation of the ratio of the peak area of butenafine to that of the internal standard is not more than 1.0%.

Containers and storage Containers—Tight containers.
Storage—Light-resistant.

Butropium Bromide

ブトロピウム臭化物

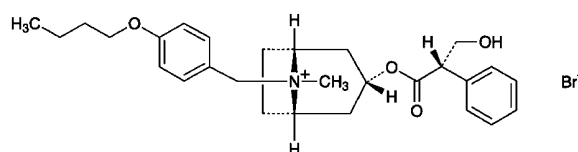

$\text{C}_{28}\text{H}_{38}\text{BrNO}_4$: 532.51

(1*R*,3*r*,5*S*)-8-(4-Butoxybenzyl)-3-[(2*S*)-hydroxy-2-phenylpropanoyloxy]-8-methyl-8-azoniabicyclo[3.2.1]octane bromide
[29025-14-7]

Butropium Bromide, when dried, contains not less than 98.0% of butropium bromide ($\text{C}_{28}\text{H}_{38}\text{BrNO}_4$).

Description Butropium Bromide occurs as white, crystals or crystalline powder.

It is very soluble in formic acid, freely soluble in methanol, soluble in ethanol (95), slightly soluble in water, and practically insoluble in diethyl ether and in acetic anhydride.

Identification (1) To 1 mg of Butropium Bromide add 3 drops of fuming nitric acid, and evaporate on a water bath to dryness. Dissolve the residue in 1 mL of *N,N*-dimethylformamide, and add 5 to 6 drops of tetraethylammonium hydroxide TS: a red-purple color develops.

(2) Determine the absorption spectrum of a solution of Butropium Bromide in methanol (1 in 100,000) as directed under Ultraviolet-visible Spectrophotometry <2.24>, and compare the spectrum with the Reference Spectrum 1: both spectra exhibit similar intensities of absorption at the same wavelengths. Separately, determine the absorption spectrum of a solution of Butropium Bromide in methanol (1 in 5000) as directed under Ultraviolet-visible Spectrophotometry <2.24>, and compare the spectrum with the Reference Spectrum 2: both spectra exhibit similar intensities of absorption at the same wavelengths.

(3) A solution of Butropium Bromide in methanol (1 in 20) responds to Qualitative Tests <1.09> (1) for bromide.

Optical rotation <2.49> $[\alpha]_D^{20}$: -14.0 – -17.0° (after drying, 0.5 g, methanol, 20 mL, 100 mm).

Purity (1) Heavy metals <1.07>—Dissolve 1.0 g of Butropium Bromide in 40 mL of ethanol (95), add 2 mL of dilute acetic acid and water to make 50 mL. Perform the test, using this solution as the test solution. Prepare the control solution with 2.0 mL of Standard Lead Solution (not more than 20 ppm).

(2) Related substances—Dissolve 50 mg of Butropium

Bromide in 10 mL of the mobile phase, and use this solution as the sample solution. Pipet 1 mL of the sample solution, add the mobile phase to make exactly 100 mL, and use this solution as the standard solution. Perform the test with exactly 5 μ L each of the sample solution and standard solution as directed under Liquid Chromatography <2.01> according to the following conditions. Determine each peak area of both solutions by the automatic integration method: the peak area, having the relative retention time about 0.5 to butropium obtained from the sample solution is not larger than 1/4 times the peak area from the standard solution, and the total area of all peaks other than the peak eluted first, the peak, having the relative retention time to butropium about 0.5 and butropium peak from the sample solution is not larger than the peak area from the standard solution.

Operating conditions—

Detector: An ultraviolet absorption photometer (wavelength: 220 nm).

Column: A stainless steel column about 5 mm in inside diameter and about 15 cm in length, packed with octadecylsilylated silica gel for liquid chromatography (5 μ m in particle diameter).

Column temperature: A constant temperature of about 40°C.

Mobile phase: Dissolve 1.15 g of sodium lauryl sulfate in 1000 mL of a mixture of acetonitrile and 0.005 mol/L sulfuric acid (3:2).

Flow rate: Adjust so that the retention time of butropium is about 5 minutes.

Selection of column: Dissolve 0.50 g of Butropium Bromide in 9 mL of ethanol (99.5) and 1 mL of 0.1 mol/L potassium hydroxide-ethanol TS, and heat at 70°C for 15 minutes. After cooling, to 1 mL of this solution add the mobile phase to make 100 mL. Proceed with 5 μ L of this solution under the above operating conditions, and calculate the resolution. Use a column giving elution of the peak of butropium and the peak having a ratio of the retention time about 0.7 to butropium with the resolution between these peaks being not less than 2.5.

Detection sensitivity: Adjust the detection sensitivity so that the peak height of the butropium obtained from 5 μ L of the standard solution is between 10 mm and 30 mm.

Time span of measurement: About twice as long as the retention time of butropium.

Loss on drying <2.41> Not more than 1.0% (1 g, 105°C, 3 hours).

Residue on ignition <2.44> Not more than 0.2% (1 g).

Assay Weigh accurately about 0.8 g of Butropium Bromide, previously dried, dissolve in 5 mL of formic acid, add 100 mL of acetic anhydride, and titrate <2.50> with 0.1 mol/L perchloric acid-dioxane VS (potentiometric titration). Perform a blank determination in the same manner, and make any necessary correction.

Each mL of 0.1 mol/L perchloric acid-dioxane VS
= 53.25 mg of C₂₈H₃₈BrNO₄

Containers and storage Containers—Well-closed containers.

Storage—Light-resistant.

Butyl Parahydroxybenzoate

パラオキシ安息香酸ブチル

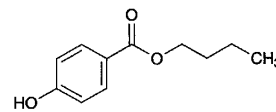

C₁₁H₁₄O₃: 194.23
Butyl 4-hydroxybenzoate
[94-26-8]

This monograph is harmonized with the European Pharmacopoeia and the U.S. Pharmacopoeia.

The parts of the text that are not harmonized are marked with symbols (◆ ◆).

Information on the harmonization with the European Pharmacopoeia and the U.S. Pharmacopoeia is available on the website of the Pharmaceuticals and Medical Devices Agency.

Butyl Parahydroxybenzoate contains not less than 98.0% and not more than 102.0% of butyl parahydroxybenzoate (C₁₁H₁₄O₃).

◆**Description** Butyl Parahydroxybenzoate occurs as colorless crystals or white crystalline powder.

It is very soluble in methanol, freely soluble in ethanol (95) and in acetone, and practically insoluble in water.◆

◆**Identification** Determine the infrared absorption spectrum of Butyl Parahydroxybenzoate as directed in the potassium bromide disk method under Infrared Spectrophotometry <2.25>, and compare the spectrum with the Reference Spectrum or the spectrum of Butyl Parahydroxybenzoate RS: both spectra exhibit similar intensities of absorption at the same wave numbers.

◆**Melting point** <2.60> 68 – 71°C

◆**Purity (1)** Clarity and color of solution—Dissolve 1.0 g of Butyl Parahydroxybenzoate in ethanol (95) to make 10 mL: the solution is clear and not more intensely colored than the following control solution.

Control solution: To 5.0 mL of Cobalt (II) Chloride CS, 12.0 mL of Iron (III) Chloride CS and 2.0 mL of Copper (II) Sulfate CS add diluted dilute hydrochloric acid (1 in 10) to make 1000 mL.

(2) Acidity—To 2 mL of the solution of Butyl Parahydroxybenzoate obtained in (1) add 3 mL of ethanol (95), add 5 mL of freshly boiled and cooled water and 0.1 mL of bromocresol green-sodium hydroxide-ethanol TS, then add 0.1 mol/L sodium hydroxide VS until the solution shows a blue color: the volume of 0.1 mol/L sodium hydroxide VS used does not exceed 0.1 mL.

◆(3) Heavy metals <1.07>—Dissolve 1.0 g of Butyl Parahydroxybenzoate in 25 mL of acetone, add 2 mL of dilute acetic acid and water to make 50 mL, and perform the test using this solution as the test solution. Prepare the control solution as follows: to 2.0 mL of Standard Lead Solution add 25 mL of acetone, 2 mL of dilute acetic acid, and water to make 50 mL (not more than 20 ppm).◆

(4) Related substances—Dissolve 50.0 mg of Butyl Parahydroxybenzoate in 2.5 mL of methanol, and add the mobile phase to make exactly 50 mL. Pipet 10 mL of this solution, add the mobile phase to make exactly 100 mL, and use this solution as the sample solution. Pipet 1 mL of the sample solution, and add the mobile phase to make exactly

20 mL. Pipet 1 mL of this solution, add the mobile phase to make exactly 10 mL, and use this solution as the standard solution. Perform the test with exactly 10 μ L each of the sample solution and standard solution as directed under Liquid Chromatography <2.01> according to the following conditions, and determine each peak area by the automatic integration method: the peak area of parahydroxybenzoic acid having a relative retention time of about 0.1 to butyl parahydroxybenzoate obtained from the sample solution is not larger than the peak area of butyl parahydroxybenzoate from the standard solution (0.5%). For the area of the peak of parahydroxybenzoic acid multiply the correction factor, 1.4. Furthermore, the area of the peak other than butyl parahydroxybenzoate and parahydroxybenzoic acid from the sample solution is not larger than the peak area of butyl parahydroxybenzoate from the standard solution (0.5%), and the total area of the peaks other than butyl parahydroxybenzoate is not larger than 2 times the peak area of butyl parahydroxybenzoate from the standard solution (1.0%). For this calculation the peak area not larger than 1/5 times the peak area of butyl parahydroxybenzoate from the standard solution is excluded (0.1%).

Operating conditions—

Detector, column, column temperature, mobile phase, and flow rate: Proceed as directed in the operating conditions in the Assay.

Time span of measurement: About 1.5 times as long as the retention time of butyl parahydroxybenzoate.

System suitability—

System performance: Proceed as directed in the system suitability in the Assay.

◆Test for required detectability: To exactly 2 mL of the standard solution add the mobile phase to make exactly 10 mL. Confirm that the peak area of butyl parahydroxybenzoate obtained with 10 μ L of this solution is equivalent to 14 to 26% of that with 10 μ L of the standard solution.◆

◆System repeatability: When the test is repeated 6 times with 10 μ L of the standard solution under the above operating conditions, the relative standard deviation of the peak area of butyl parahydroxybenzoate is not more than 2.0%.◆

Residue on ignition <2.44> Not more than 0.1% (1 g).

Assay Weigh accurately about 50.0 mg each of Butyl Parahydroxybenzoate and Butyl Parahydroxybenzoate RS, dissolve separately in 2.5 mL each of methanol, and add the mobile phase to make exactly 50 mL. Pipet 10 mL each of these solutions, add the mobile phase to make exactly 100 mL, and use these solutions as the sample solution and the standard solution, respectively. Perform the test with exactly 10 μ L each of the sample solution and standard solution as directed under Liquid Chromatography <2.01> according to the following conditions, and determine the peak areas, A_T and A_S , of butyl parahydroxybenzoate in each solution.

$$\text{Amount (mg) of butyl parahydroxybenzoate (C}_{11}\text{H}_{14}\text{O}_3) \\ = M_S \times A_T / A_S$$

M_S : Amount (mg) of Butyl Parahydroxybenzoate RS taken

Operating conditions—

Detector: An ultraviolet absorption photometer (wavelength: 272 nm).

Column: A stainless steel column 4.6 mm in inside diameter and 15 cm in length, packed with octadecylsilanized silica gel for liquid chromatography (5 μ m in particle diameter).

Column temperature: A constant temperature of about 35°C.

Mobile phase: A mixture of methanol and potassium dihydrogen phosphate solution (17 in 2500) (1:1).

Flow rate: 1.3 mL per minute.

System suitability—

System performance: Dissolve 5 mg each of Butyl Parahydroxybenzoate, propyl parahydroxybenzoate and parahydroxybenzoic acid in the mobile phase to make exactly 100 mL. Pipet 1 mL of this solution, add the mobile phase to make exactly 10 mL, and use this solution as the solution for system suitability test (1). Separately, dissolve 5 mg of isobutyl parahydroxybenzoate in the mobile phase to make exactly 100 mL. Pipet 0.5 mL of this solution, add the standard solution to make exactly 50 mL, and use this solution as the solution for system suitability test (2). When the procedure is run with 10 μ L each of the solution for system suitability test (1) and (2) under the above operating conditions, parahydroxybenzoic acid, propyl parahydroxybenzoate, isobutyl parahydroxybenzoate and butyl parahydroxybenzoate are eluted in this order, the relative retention times of parahydroxybenzoic acid, propyl parahydroxybenzoate and isobutyl parahydroxybenzoate to butyl parahydroxybenzoate are about 0.1, about 0.5 and about 0.9, respectively, the resolution between the peaks of propyl parahydroxybenzoate and butyl parahydroxybenzoate is not less than 5.0, and the resolution between the peaks of isobutyl parahydroxybenzoate and butyl parahydroxybenzoate is not less than 1.5.

System repeatability: When the test is repeated 6 times with 10 μ L of the standard solution under the above operating conditions, the relative standard deviation of the peak area of butyl parahydroxybenzoate is not more than 0.85%.

◆**Containers and storage** Containers—Well-closed containers.◆

Cabergoline

カベルゴリン

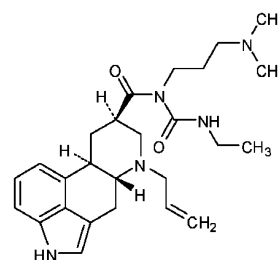

$\text{C}_{26}\text{H}_{37}\text{N}_5\text{O}_2$: 451.60
(8*R*)-6-Allyl-*N*-[3-(dimethylamino)propyl]-*N*-(ethylcarbamoyl)ergoline-8-carboxamide
[81409-90-7]

Cabergoline contains not less than 98.0% and not more than 102.0% of cabergoline ($\text{C}_{26}\text{H}_{37}\text{N}_5\text{O}_2$), calculated on the anhydrous basis.

Description Cabergoline occurs as a white crystalline powder.

It is very soluble in methanol, freely soluble in ethanol (95), and very slightly soluble in water.

It is gradually colored to yellow by light.

It shows crystal polymorphism.

Identification (1) Determine the absorption spectrum of a solution of Cabergoline in ethanol (95) (1 in 30,000) as directed under Ultraviolet-visible Spectrophotometry <2.24>, and compare the spectrum with the Reference Spectrum or

the spectrum of a solution of Cabergoline RS prepared in the same manner as the sample solution: both spectra exhibit similar intensities of absorption at the same wavelengths.

(2) Determine the infrared absorption spectrum of Cabergoline as directed in the potassium bromide disk method under Infrared Spectrophotometry <2.25>, and compare the spectrum with the Reference Spectrum or the spectrum of Cabergoline RS: both spectra exhibit similar intensities of absorption at the same wave numbers. If any difference appears between the spectra, dissolve Cabergoline and Cabergoline RS in ethanol (95), respectively, then evaporate the ethanol, dry the residues, and repeat the test on the residues.

Optical rotation <2.49> $[\alpha]_D^{20}$: $-77 - -83^\circ$ (0.1 g calculated on the anhydrous basis, ethanol (95), 50 mL, 100 mm).

Purity (1) Heavy metals <1.07>—Proceed with 1.0 g of Cabergoline according to Method 4, and perform the test. Prepare the control solution with 2.0 mL of Standard Lead Solution (not more than 20 ppm).

(2) Related substances—Conduct this procedure using light-resistant vessels. Perform the test with 20 μ L of the sample solution obtained in the Assay as directed under Liquid Chromatography <2.01> according to the following conditions. Determine each peak area by the automatic integration method, and calculate the amounts of them by the area percentage method: the amount of related substances A and B, having the relative retention times of about 0.8 and about 2.8 to cabergoline are not more than 0.5%, respectively, and the amount of the peak other than cabergoline and the peaks mentioned above is not more than 0.1%. Furthermore, the total amount of the peaks other than cabergoline is not more than 1.5%.

Operating conditions—

Detector, column, column temperature, mobile phase, and flow rate: Proceed as directed in the operating conditions in the Assay.

Time span of measurement: About 4 times as long as the retention time of cabergoline, beginning after the solvent peak.

System suitability—

System performance: Proceed as directed in the system suitability in the Assay.

Test for required detectability: Use the diluted sample solution (1 in 500) as the solution for system suitability test. Pipet 5 mL of the solution for system suitability test, and add the mobile phase to make exactly 20 mL. Confirm that the peak area of cabergoline obtained with 20 μ L of this solution is equivalent to 18 to 32% of that with 20 μ L of the solution for system suitability test.

System repeatability: When the test is repeated 6 times with 20 μ L of the solution for system suitability test under the above operating conditions, the relative standard deviation of the peak area of cabergoline is not more than 2.0%.

Water <2.48> Not more than 0.5% (1 g, volumetric titration, direct titration).

Assay Conduct this procedure using light-resistant vessels. Weigh accurately about 30 mg each of Cabergoline and Cabergoline RS (separately determine the water <2.48> in the same manner as Cabergoline), dissolve each in the mobile phase to make exactly 25 mL, and use these solutions as the sample solution and the standard solution, respectively. Perform the test with exactly 20 μ L each of the sample solution and standard solution as directed under Liquid Chromatography <2.01> according to the following conditions, and determine the peak areas, A_T and A_S , of cabergoline in each so-

lution.

Amount (mg) of cabergoline ($C_{26}H_{37}N_5O_2$) = $M_S \times A_T/A_S$

M_S : Amount (mg) of Cabergoline RS taken, calculated on the anhydrous basis

Operating conditions—

Detector: An ultraviolet absorption photometer (wavelength: 280 nm).

Column: A stainless steel column 4.0 mm in inside diameter and 25 cm in length, packed with octadecylsilanized silica gel for liquid chromatography (10 μ m in particle diameter).

Column temperature: A constant temperature of about 25°C.

Mobile phase: Dissolve 6.8 g of potassium dihydrogen phosphate in 900 mL of water, adjust to pH 2.0 with phosphoric acid, and add water to make 1000 mL. To this solution add 0.2 mL of triethylamine. To 840 mL of this solution add 160 mL of acetonitrile.

Flow rate: Adjust so that the retention time of cabergoline is about 12 minutes.

System suitability—

System performance: Suspend 50 mg of Cabergoline in 10 mL of 0.1 mol/L sodium hydroxide TS, and stir for 15 minutes. To 1 mL of this solution add 1 mL of 0.1 mol/L hydrochloric acid TS, and add the mobile phase to make 10 mL. When the procedure is run with 20 μ L of this solution under the above operating conditions, the resolution between the peaks of related substance A having the relative retention time of about 0.8 to cabergoline and cabergoline is not less than 3.

System repeatability: When the test is repeated 6 times with 20 μ L of the standard solution under the above operating conditions, the relative standard deviation of the peak area of cabergoline is not more than 1.0%.

Containers and storage Containers—Tight containers.

Storage—Light-resistant.

Others

Related substance A:

(8*R*)-6-Allylergoline-8-carboxylic acid

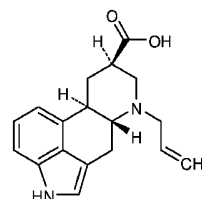

Related substance B:

(8*R*)-6-Allyl-*N*-[3-(dimethylamino)propyl]-*N*,1-bis(ethylcarbamoyl)ergoline-8-carboxamide

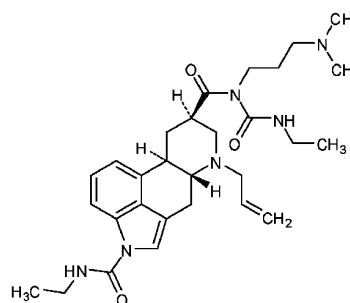

Cadralazine

カドララジン

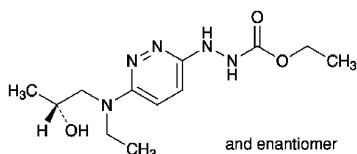
C₁₂H₂₁N₅O₃; 283.33Ethyl 3-(6-{ethyl[(2*RS*)-2-hydroxypropyl]amino}pyridazin-3-yl)carbazate

[64241-34-5]

Cadralazine, when dried, contains not less than 98.5% and not more than 101.0% of cadralazine (C₁₂H₂₁N₅O₃).

Description Cadralazine occurs as a pale yellow to light yellow crystalline powder.

It is freely soluble in acetic acid (100), soluble in methanol, sparingly soluble in ethanol (99.5), and slightly soluble in water.

It dissolves in 0.05 mol/L sulfuric acid TS.

A solution of Cadralazine in methanol (1 in 40) shows no optical rotation.

Melting point: about 165°C (with decomposition).

Identification (1) Determine the absorption spectrum of a solution of Cadralazine in 0.05 mol/L sulfuric acid TS (1 in 125,000) as directed under Ultraviolet-visible Spectrophotometry <2.24>, and compare the spectrum with the Reference Spectrum: both spectra exhibit similar intensities of absorption at the same wavelengths.

(2) Determine the infrared absorption spectrum of Cadralazine, previously dried, as directed in the potassium bromide disk method under Infrared Spectrophotometry <2.25>, and compare the spectrum with the Reference Spectrum: both spectra exhibit similar intensities of absorption at the same wave numbers.

Purity (1) Chloride <1.03>—Dissolve 0.40 g of Cadralazine in 15 mL of methanol, add 6 mL of dilute nitric acid and water to make 50 mL. Perform the test using this solution as the test solution. Prepare the control solution with 0.40 mL of 0.01 mol/L hydrochloric acid VS by adding 15 mL of methanol, 6 mL of dilute nitric acid, and water to make 50 mL (not more than 0.036%).

(2) Heavy metals <1.07>—Proceed with 1.0 g of Cadralazine according to Method 4, and perform the test. Prepare the control solution with 2.0 mL of Standard Lead Solution (not more than 20 ppm).

(3) Related substances—Dissolve 50 mg of Cadralazine in 20 mL of 0.05 mol/L sulfuric acid TS, add water to 100 mL, and use this solution as the sample solution. Pipet 1 mL of the sample solution, add water to make exactly 200 mL, and use this solution as the standard solution. Perform the test with exactly 10 μL each of the sample solution and standard solution as directed under Liquid Chromatography <2.01> according to the following conditions. Determine each peak area of both solutions by the automatic integration method: the area of the peak, having the relative retention time of about 2.1 to cadralazine, obtained from the sample solution is not larger than the peak area of cadralazine from the standard solution, and the area of the peak other than cadralazine and the peak mentioned above is not larger than 2/5 times the peak area of cadralazine from the standard

solution. Furthermore, the total area of the peaks other than cadralazine from the sample solution is not larger than 2 times the peak area of cadralazine from the standard solution. For the areas of the peaks, having the relative retention time of about 0.49 and about 2.1 to cadralazine, multiply their correction factors, 0.65 and 1.25, respectively.

Operating conditions—

Detector: An ultraviolet absorption photometer (wavelength: 250 nm).

Column: A stainless steel column 4.6 mm in inside diameter and 15 cm in length, packed with octadecylsilanized silica gel for liquid chromatography (5 μm in particle diameter).

Column temperature: A constant temperature of about 40°C.

Mobile phase: Dissolve 13.6 g of sodium acetate trihydrate in 800 mL of water, adjust the pH to 5.8 with dilute acetic acid, and add water to make 1000 mL. To 860 mL of this solution add 140 mL of acetonitrile.

Flow rate: Adjust so that the retention time of cadralazine is about 10 minutes.

Time span of measurement: About 3 times as long as the retention time of cadralazine.

System suitability—

Test for required detectability: Pipet 5 mL of the standard solution, and add water to make exactly 25 mL. Confirm that the peak area of cadralazine obtained with 10 μL of this solution is equivalent to 15 to 25% of that with 10 μL of the standard solution.

System performance: When the procedure is run with 10 μL of the standard solution under the above operating conditions, the number of theoretical plates and the symmetry factor of the peak of cadralazine are not less than 4000 and not more than 1.5, respectively.

System repeatability: When the test is repeated 6 times with 10 μL of the standard solution under the above operating conditions, the relative standard deviation of the peak area of cadralazine is not more than 4.0%.

Loss on drying <2.41> Not more than 1.0% (1 g, 105°C, 3 hours).

Residue on ignition <2.44> Not more than 0.1% (1 g).

Assay Weigh accurately about 0.5 g of Cadralazine, previously dried, dissolve in 50 mL of acetic acid (100), and titrate <2.50> with 0.1 mol/L perchloric acid VS (potentiometric titration). Perform a blank determination in the same manner, and make any necessary correction.

Each mL of 0.1 mol/L perchloric acid VS
= 28.33 mg of C₁₂H₂₁N₅O₃

Containers and storage Containers—Well-closed containers.

Cadralazine Tablets

カドララジン錠

Cadralazine Tablets contain not less than 95.0% and not more than 105.0% of the labeled amount of cadralazine (C₁₂H₂₁N₅O₃; 283.33).

Method of preparation Prepare as directed under Tablets, with Cadralazine.

Identification To a quantity of powdered Cadralazine Tablets, equivalent to 20 mg of Cadralazine, add 50 mL of 0.05 mol/L sulfuric acid TS, shake well, and centrifuge. To

1 mL of the supernatant liquid add 0.05 mol/L sulfuric acid TS to make 50 mL. Determine the absorption spectrum of this solution as directed under Ultraviolet-visible Spectrophotometry <2.24>: it exhibits a maximum between 247 nm and 251 nm.

Uniformity of dosage units <6.02> Perform the test according to the following method: it meets the requirement of the Content uniformity test.

To 1 tablet of Cadralazine Tablets add 30 mL of 0.05 mol/L sulfuric acid TS, shake well to disintegrate, and add 0.05 mol/L sulfuric acid TS to make exactly 50 mL. Centrifuge this solution, pipet 3 mL of the supernatant liquid, add 0.05 mol/L sulfuric acid TS to make exactly V mL so that each mL contains about $6 \mu\text{g}$ of cadralazine ($\text{C}_{12}\text{H}_{21}\text{N}_5\text{O}_3$), and use this solution as the sample solution. Separately, weigh accurately about 20 mg of cadralazine for assay, previously dried at 105°C for 3 hours, and dissolve in 0.05 mol/L sulfuric acid TS to make exactly 100 mL. Pipet 3 mL of this solution, add 0.05 mol/L sulfuric acid TS to make exactly 100 mL, and use this solution as the standard solution. Determine the absorbances, A_T and A_S , of the sample solution and standard solution at 249 nm as directed under Ultraviolet-visible Spectrophotometry <2.24>.

$$\begin{aligned} &\text{Amount (mg) of cadralazine (C}_{12}\text{H}_{21}\text{N}_5\text{O}_3) \\ &= M_S \times A_T/A_S \times V/200 \end{aligned}$$

M_S : Amount (mg) of cadralazine for assay taken

Dissolution <6.10> When the test is performed at 50 revolutions per minute according to the Paddle method, using 900 mL of water as the dissolution medium, the dissolution rate in 30 minutes of Cadralazine Tablets is not less than 80%.

Start the test with 1 tablet of Cadralazine Tablets, withdraw not less than 20 mL of the medium at the specified minute after starting the test, and filter through a membrane filter with a pore size not exceeding $0.5 \mu\text{m}$. Discard not less than 10 mL of the first filtrate, pipet V' mL of the subsequent filtrate, add water to make exactly V' mL so that each mL contains about $5.6 \mu\text{g}$ of cadralazine ($\text{C}_{12}\text{H}_{21}\text{N}_5\text{O}_3$), and use this solution as the sample solution. Separately, weigh accurately about 30 mg of cadralazine for assay, previously dried at 105°C for 3 hours, and dissolve in water to make exactly 200 mL. Pipet 4 mL of this solution, add water to make exactly 100 mL, and use this solution as the standard solution. Determine the absorbances, A_T and A_S , of the sample solution and standard solution at 254 nm as directed under Ultraviolet-visible Spectrophotometry <2.24>.

$$\begin{aligned} &\text{Dissolution rate (\%)} \text{ with respect to the labeled amount} \\ &\text{of cadralazine (C}_{12}\text{H}_{21}\text{N}_5\text{O}_3) \\ &= M_S \times A_T/A_S \times V'/V \times 1/C \times 18 \end{aligned}$$

M_S : Amount (mg) of cadralazine for assay taken

C : Labeled amount (mg) of cadralazine ($\text{C}_{12}\text{H}_{21}\text{N}_5\text{O}_3$) in 1 tablet

Assay To 10 Cadralazine Tablets add 70 mL of 0.05 mol/L sulfuric acid TS, shake well to disintegrate, add 0.05 mol/L sulfuric acid TS to make exactly 200 mL. Centrifuge this solution, pipet a volume of the supernatant liquid, equivalent to about 2.5 mg of cadralazine ($\text{C}_{12}\text{H}_{21}\text{N}_5\text{O}_3$), add exactly 5 mL of the internal standard solution, add water to make 25 mL, and use this solution as the sample solution. Separately, weigh accurately about 25 mg of cadralazine for assay, previously dried at 105°C for 3 hours, and dissolve in 0.05 mol/L of sulfuric acid TS to make exactly 50 mL. Pipet 5 mL of this solution, add exactly 5 mL of the internal standard solution, add water to make 25 mL, and use this solution

as the standard solution. Perform the test with $5 \mu\text{L}$ each of the sample solution and standard solution as directed under Liquid Chromatography <2.01> according to the following conditions, and calculate the ratios, Q_T and Q_S , of the peak area of cadralazine to that of the internal standard.

$$\begin{aligned} &\text{Amount (mg) of cadralazine (C}_{12}\text{H}_{21}\text{N}_5\text{O}_3) \\ &= M_S \times Q_T/Q_S \times 1/10 \end{aligned}$$

M_S : Amount (mg) of cadralazine for assay taken

Internal standard solution—A solution of *p*-toluenesulfonamide in acetonitrile (1 in 50).

Operating conditions—

Detector: An ultraviolet absorption photometer (wavelength: 250 nm).

Column: A stainless steel column 4.6 mm in inside diameter and 15 cm in length, packed with octadecylsilanized silica gel for liquid chromatography ($5 \mu\text{m}$ in particle diameter).

Column temperature: A constant temperature of about 40°C .

Mobile phase: Dissolve 13.6 g of sodium acetate trihydrate in 800 mL of water, adjust the pH to 5.8 with dilute acetic acid, and add water to make 1000 mL. To 860 mL of this solution add 140 mL of acetonitrile.

Flow rate: Adjust so that the retention time of cadralazine is about 10 minutes.

System suitability—

System performance: When the procedure is run with $5 \mu\text{L}$ of the standard solution under the above operating conditions, cadralazine and the internal standard are eluted in this order with the resolution between these peaks being not less than 3.

System repeatability: When the test is repeated 6 times with $5 \mu\text{L}$ of the standard solution under the above operating conditions, the relative standard deviation of the ratio of the peak area of cadralazine to that of the internal standard is not more than 1.0%.

Containers and storage Containers—Well-closed containers.

Anhydrous Caffeine

無水カフェイン

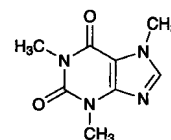

$\text{C}_8\text{H}_{10}\text{N}_4\text{O}_2$: 194.19

1,3,7-Trimethyl-1*H*-purine-2,6(3*H*,7*H*)-dione
[58-08-2]

Anhydrous Caffeine, when dried, contains not less than 98.5% of caffeine ($\text{C}_8\text{H}_{10}\text{N}_4\text{O}_2$).

Description Anhydrous Caffeine occurs as white, crystals or powder. It is odorless, and has a bitter taste.

It is freely soluble in chloroform, sparingly soluble in water, in acetic acid (100) and in acetic anhydride, and slightly soluble in ethanol (95) and in diethyl ether.

The pH of a solution of 1.0 g of Anhydrous Caffeine in 100 mL of water is between 5.5 and 6.5.

Identification (1) To 2 mL of a solution of Anhydrous Caffeine (1 in 500) add tannic acid TS dropwise: a white

precipitate, which dissolves upon the dropwise addition of tannic acid TS, is produced.

(2) To 0.01 g of Anhydrous Caffeine add 10 drops of hydrogen peroxide TS and 1 drop of hydrochloric acid, and evaporate on a water bath to dryness: the residue acquires a yellow-red color. Invert the residue over a vessel containing 2 to 3 drops of ammonia TS: the color turns red-purple, and disappears upon the addition of 2 to 3 drops of sodium hydroxide TS.

(3) Dissolve 0.01 g of Anhydrous Caffeine in water to make 50 mL. To 5 mL of this solution add 3 mL of diluted acetic acid (31) (3 in 100) and 5 mL of pyridine (1 in 10), mix, add 2 mL of diluted sodium hypochlorite TS (1 in 5), and allow to stand for 1 minute. Add 2 mL of sodium thiosulfate TS and 5 mL of sodium hydroxide TS to the solution: a yellow color develops.

Melting point <2.60> 235 – 238°C

Purity (1) Chloride <1.03>—Dissolve 2.0 g of Anhydrous Caffeine in 80 mL of hot water, cool rapidly to 20°C, add water to make 100 mL, and use this solution as the sample solution. To 40 mL of the sample solution add 6 mL of dilute nitric acid and water to make 50 mL. Perform the test using this solution as the test solution. Prepare the control solution with 0.25 mL of 0.01 mol/L hydrochloric acid VS (not more than 0.011%).

(2) Sulfate <1.14>—To 40 mL of the sample solution obtained in (1) add 1 mL of dilute hydrochloric acid and water to make 50 mL. Perform the test using this solution as the test solution. Prepare the control solution with 0.40 mL of 0.005 mol/L sulfuric acid VS (not more than 0.024%).

(3) Heavy metals <1.07>—Proceed with 2.0 g of Anhydrous Caffeine according to Method 2, and perform the test. Prepare the control solution with 2.0 mL of Standard Lead Solution (not more than 10 ppm).

(4) Related substances—Dissolve 0.10 g of Anhydrous Caffeine in 10 mL of chloroform, and use this solution as the sample solution. Pipet 1 mL of the sample solution, and add chloroform to make exactly 100 mL. Pipet 1 mL of this solution, add chloroform to make exactly 10 mL, and use this solution as the standard solution. Perform the test with these solutions as directed under Thin-layer Chromatography <2.03>. Spot 10 μL each of the sample solution and standard solution on a plate of silica gel with fluorescent indicator for thin-layer chromatography. Develop the plate with a mixture of chloroform and ethanol (95) (9:1) to a distance of about 10 cm, and air-dry the plate. Examine under ultraviolet light (main wavelength: 254 nm): the spots other than the principal spot obtained from the sample solution are not more intense than the spot from the standard solution.

(5) Readily carbonizable substances <1.15>—Perform the test using 0.5 g of Anhydrous Caffeine: the solution is not more colored than Matching Fluid D.

Loss on drying <2.41> Not more than 0.5% (1 g, 80°C, 4 hours).

Residue on ignition <2.44> Not more than 0.1% (0.5 g).

Assay Weigh accurately about 0.4 g of Anhydrous Caffeine, previously dried, dissolve in 70 mL of a mixture of acetic anhydride and acetic acid (100) (6:1), and titrate <2.50> with 0.1 mol/L perchloric acid VS until the solution changes from purple through green to yellow (indicator: 3 drops of crystal violet TS). Perform a blank determination in the same manner, and make any necessary correction.

Each mL of 0.1 mol/L perchloric acid VS
= 19.42 mg of C₈H₁₀N₄O₂

Containers and storage Containers—Tight containers.

Caffeine Hydrate

カフェイン水和物

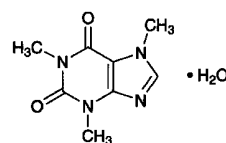

C₈H₁₀N₄O₂·H₂O: 212.21

1,3,7-Trimethyl-1*H*-purine-2,6(3*H*,7*H*)-dione
monohydrate

[5743-12-4]

Caffeine Hydrate, when dried, contains not less than 98.5% of caffeine (C₈H₁₀N₄O₂: 194.19).

Description Caffeine Hydrate occurs as white, soft crystals or powder. It is odorless, and has a slightly bitter taste.

It is freely soluble in chloroform, sparingly soluble in water, in acetic acid (100) and in acetic anhydride, slightly soluble in ethanol (95), and very slightly soluble in diethyl ether.

The pH of a solution of 1.0 g of Caffeine Hydrate in 100 mL of water is between 5.5 and 6.5.

It effloresces in dry air.

Identification (1) To 2 mL of a solution of Caffeine Hydrate (1 in 500) add tannic acid TS dropwise: a white precipitate, which dissolves upon the dropwise addition of tannic acid TS, is produced.

(2) To 0.01 g of Caffeine Hydrate add 10 drops of hydrogen peroxide TS and 1 drop of hydrochloric acid, and evaporate to dryness on a water bath: the residue acquires a yellow-red color. Invert the residue over a vessel containing 2 to 3 drops of ammonia TS: the color turns red-purple, and disappears upon the addition of 2 to 3 drops of sodium hydroxide TS.

(3) Dissolve 0.01 g of Caffeine Hydrate in water to make 50 mL. To 5 mL of this solution add 3 mL of diluted acetic acid (31) (3 in 100) and 5 mL of a solution of pyridine (1 in 10), mix, add 2 mL of diluted sodium hypochlorite TS (1 in 5), and allow to stand for 1 minute. Add 2 mL of sodium thiosulfate TS and 5 mL of sodium hydroxide TS to the solution: a yellow color develops.

Melting point <2.60> 235 – 238°C (after drying).

Purity (1) Chloride <1.03>—Dissolve 2.0 g of Caffeine Hydrate in 80 mL of hot water, cool rapidly to 20°C, add water to make 100 mL, and use this solution as the sample solution. To 40 mL of the sample solution add 6 mL of dilute nitric acid and water to make 50 mL. Perform the test using this solution as the test solution. Prepare the control solution with 0.25 mL of 0.01 mol/L hydrochloric acid VS (not more than 0.011%).

(2) Sulfate <1.14>—To 40 mL of the sample solution obtained in (1) add 1 mL of dilute hydrochloric acid and water to make 50 mL. Perform the test using this solution as the test solution. Prepare the control solution with 0.40 mL of 0.005 mol/L sulfuric acid VS (not more than 0.024%).

(3) Heavy metals <1.07>—Proceed with 2.0 g of Caffeine Hydrate according to Method 2, and perform the test. Pre-

pare the control solution with 2.0 mL of Standard Lead Solution (not more than 10 ppm).

(4) Related substances—Dissolve 0.10 g of Caffeine Hydrate in 10 mL of chloroform, and use this solution as the sample solution. Pipet 1 mL of the sample solution, and add chloroform to make exactly 100 mL. Pipet 1 mL of this solution, add chloroform to make exactly 10 mL, and use this solution as the standard solution. Perform the test as directed under Thin-layer Chromatography <2.03>. Spot 10 μ L each of the sample solution and standard solution on a plate of silica gel with fluorescent indicator for thin-layer chromatography. Develop the plate with a mixture of chloroform and ethanol (95) (9:1) to a distance of about 10 cm, and air-dry the plate. Examine under ultraviolet light (main wavelength: 254 nm): the spots other than the principal spot obtained from the sample solution are not more intense than the spot from the standard solution.

(5) Readily carbonizable substances <1.15>—Perform the test using 0.5 g of Caffeine Hydrate: the solution is not more colored than Matching Fluid D.

Loss on drying <2.41> 0.5 – 8.5% (1 g, 80°C, 4 hours).

Residue on ignition <2.44> Not more than 0.1% (0.5 g).

Assay Weigh accurately about 0.4 g of Caffeine Hydrate, previously dried, dissolve in 70 mL of a mixture of acetic anhydride and acetic acid (100) (6:1), and titrate <2.50> with 0.1 mol/L perchloric acid VS until the solution changes from purple through green to yellow (indicator: 3 drops of crystal violet TS). Perform a blank determination in the same manner, and make any necessary correction.

Each mL of 0.1 mol/L perchloric acid VS
= 19.42 mg of $C_8H_{10}N_4O_2$

Containers and storage Containers—Tight containers.

Caffeine and Sodium Benzoate

安息香酸ナトリウムカフェイン

Caffeine and Sodium Benzoate, when dried, contains not less than 48.0% and not more than 50.0% of caffeine ($C_8H_{10}N_4O_2$: 194.19), and not less than 50.0% and not more than 52.0% of sodium benzoate ($C_7H_5NaO_2$: 144.10).

Description Caffeine and Sodium Benzoate occurs as a white powder. It is odorless, and has a slightly bitter taste.

It is freely soluble in water, soluble in acetic acid (100) and in acetic anhydride, sparingly soluble in ethanol (95), and practically insoluble in diethyl ether.

Identification (1) Dissolve 1 g of Caffeine and Sodium Benzoate in 10 mL of water in a separator, add 1 drop of phenolphthalein TS, and add carefully 0.01 mol/L sodium hydroxide VS dropwise until a faint red color develops. Extract with three 20-mL portions of chloroform by thorough shaking, and separate the chloroform layer from the water layer. [Use the water layer for test (2).] Filter the combined chloroform extracts, evaporate the filtrate to dryness on a water bath, and proceed the following tests with the residue:

(i) To 2 mL of a solution of the residue (1 in 500) add tannic acid TS dropwise: a white precipitate, which dissolves upon the dropwise addition of tannic acid TS, is produced.

(ii) To 0.01 g of the residue add 10 drops of hydrogen peroxide TS and 1 drop of hydrochloric acid, evaporate to dryness on a water bath: the residue acquires a yellow-red

color. Invert the residue over a vessel containing 2 to 3 drops of ammonia TS: the color turns red-purple, and disappears upon the addition of 2 to 3 drops of sodium hydroxide TS.

(iii) Dissolve 0.01 g of the residue in water to make 50 mL. To 5 mL of this solution add 3 mL of diluted acetic acid (31) (3 in 100) and 5 mL of a solution of pyridine (1 in 10), mix, add 2 mL of diluted sodium hypochlorite TS (1 in 5), and allow to stand for 1 minute. Add 2 mL of sodium thio-sulfate TS and 5 mL of sodium hydroxide TS to the solution: a yellow color develops.

(2) To 5 mL of the water layer obtained in (1) add 5 mL of water: the solution responds to the Qualitative Tests <1.09> (2) for benzoate.

(3) Heat Caffeine and Sodium Benzoate: white fumes are evolved. Ignite furthermore, and to the residue add hydrochloric acid: bubbles are produced, and the solution responds to Qualitative Tests <1.09> (1) for sodium salt.

Purity (1) Clarity and color of solution—Dissolve 1.0 g of Caffeine and Sodium Benzoate in 5 mL of water: the solution is clear and colorless.

(2) Alkalinity—Dissolve 1.0 g of Caffeine and Sodium Benzoate in 20 mL of water, and add 1 or 2 drops of phenolphthalein TS: no red color develops.

(3) Chloride <1.03>—Dissolve 0.5 g of Caffeine and Sodium Benzoate in 10 mL of water, and add 30 mL of ethanol (95), 6 mL of dilute nitric acid and water to make 50 mL. Perform the test using this solution as the test solution. Prepare the control solution with 0.70 mL of 0.01 mol/L hydrochloric acid VS, 30 mL of ethanol (95) and water to make 50 mL (not more than 0.050%).

(4) Chlorinated compounds—Dissolve 1.0 g of Caffeine and Sodium Benzoate in 40 mL of water, add 10 mL of dilute sulfuric acid, and extract with two 20-mL portions of diethyl ether. Allow the combined diethyl ether extracts to evaporate at room temperature to dryness. Place this residue and 0.7 g of calcium carbonate in a crucible, mix with a small amount of water, and dry. Ignite at about 600°C, dissolve the residue in 20 mL of dilute nitric acid, and filter. Wash the residue with 15 mL of water, combine the filtrate and the washings, and add water to make 50 mL. To this solution add 0.5 mL of silver nitrate TS: the solution is not more turbid than the following control solution to which 0.5 mL of silver nitrate TS has been added.

Control solution: Dissolve 0.7 g of calcium carbonate in 20 mL of dilute nitric acid, and filter. Wash the residue with 15 mL of water, combine the filtrate and the washings, and add 1.2 mL of 0.01 mol/L hydrochloric acid VS and water to make 50 mL.

(5) Heavy metals <1.07>—Dissolve 2.0 g of Caffeine and Sodium Benzoate in 47 mL of water, add slowly, with vigorous stirring, 3 mL of dilute hydrochloric acid, and filter. Discard the first 5 mL of the filtrate, neutralize the subsequent 25 mL of the filtrate with ammonia TS, and add 2 mL of dilute acetic acid and water to make 50 mL. Perform the test using this solution as the test solution. Prepare the control solution with 2.0 mL of Standard Lead Solution by adding 2 mL of dilute acetic acid and water to make 50 mL (not more than 20 ppm).

(6) Arsenic <1.11>—Prepare the test solution with 1.0 g of Caffeine and Sodium Benzoate according to Method 1, and perform the test (not more than 2 ppm).

(7) Phthalic acid—To 0.10 g of Caffeine and Sodium Benzoate add 1 mL of water and 1 mL of resorcinol-sulfuric acid TS, and heat the mixture in an oil bath heated at a temperature between 120°C and 125°C to evaporate the water, then heat the residue for further 90 minutes, cool, and dis-

solve in 5 mL of water. To 1 mL of the solution add 10 mL of a solution of sodium hydroxide (43 in 500), shake, then examine under light at a wavelength between 470 nm and 490 nm: the green fluorescence of the solution is not more intense than that of the following control solution.

Control solution: Dissolve 61 mg of potassium hydrogen phthalate in water to make exactly 1000 mL. Pipet exactly 1 mL of the solution, add 1 mL of resorcinol-sulfuric acid TS, and proceed as directed above.

(8) Readily carbonizable substances <1.15>—Proceed with 0.5 g of Caffeine and Sodium Benzoate, and perform the test: the solution is not more colored than Matching Fluid A.

Loss on drying <2.41> Not more than 3.0% (2 g, 80°C, 4 hours).

Assay (1) Sodium benzoate—Weigh accurately about 0.2 g of Caffeine and Sodium Benzoate, previously dried, dissolve by warming in 50 mL of a mixture of acetic anhydride and acetic acid (100) (6:1), cool, and titrate <2.50> with 0.1 mol/L perchloric acid-dioxane VS to the first equivalence point (potentiometric titration). Perform a blank determination in the same manner, and make any necessary correction.

Each mL of 0.1 mol/L perchloric acid-dioxane VS
= 14.41 mg of C₇H₅NaO₂

(2) Caffeine—Continue the titration <2.50> in (1) with 0.1 mol/L perchloric acid-dioxane VS from the first equivalence point to the second equivalence point (potentiometric titration).

Each mL of 0.1 mol/L perchloric acid-dioxane VS
= 19.42 mg of C₈H₁₀N₄O₂

Containers and storage Containers—Well-closed containers.

Calcitonin Salmon

カルシトニン サケ

CSNLSTCVLG KLSQELHKLQ TYPRNTGSG TP-NH₂

C₁₄₅H₂₄₀N₄₄O₄₈S₂: 3431.85
[47931-85-1]

Calcitonin Salmon is synthetic salmon calcitonin, and is a peptide consisting of 32 amino acid residues.

It contains not less than 4000 Units of calcitonin salmon per 1 mg of peptide.

Description Calcitonin Salmon occurs as a white powder.

It is freely soluble in water.

It dissolves in dilute acetic acid.

Dissolve 20 mg of Calcitonin Salmon in 2 mL of water: the pH of the solution is between 5.0 and 7.0.

It is hygroscopic.

Identification Dissolve 1 mg of Calcitonin Salmon in 1 mL of dilute acetic acid. Determine the absorption spectrum of this solution as directed under Ultraviolet-visible Spectrophotometry <2.24>, and compare the spectrum with the Reference Spectrum: both spectra exhibit similar intensities of absorption at the same wavelengths.

Absorbance <2.24> $E_{1\text{cm}}^{1\%}$ (275 nm): 3.3 – 4.0 (1 mg, dilute acetic acid, 1 mL).

Optical rotation <2.49> $[\alpha]_D^{20}$: –24 – –32° (25 mg, diluted acetic acid (100) (1 in 2), 10 mL, 100 mm).

Constituent amino acids Weigh accurately about 1 mg of Calcitonin Salmon, put in a test tube for hydrolysis, dissolve in 0.5 mL of diluted hydrochloric acid (1 in 2), freeze in a dry ice-acetone bath, seal the tube under reduced pressure, and heat at 110 ± 2°C for 24 hours. After cooling, open the tube, evaporate the hydrolyzate to dryness under reduced pressure, dissolve the residue in exactly 5 mL of 0.02 mol/L hydrochloric acid TS, and use this solution as the sample solution. Separately, weigh accurately about 27 mg of L-aspartic acid, about 24 mg of L-threonine, about 21 mg of L-serine, about 29 mg of L-glutamic acid, about 23 mg of L-proline, about 15 mg of glycine, about 18 mg of L-alanine, about 23 mg of L-valine, about 48 mg of L-cystine, about 30 mg of methionine, about 26 mg of L-isoleucine, about 26 mg of L-leucine, about 36 mg of L-tyrosine, about 33 mg of phenylalanine, about 37 mg of L-lysine hydrochloride, about 42 mg of L-histidine hydrochloride monohydrate and about 42 mg of L-arginine hydrochloride, dissolve them in 10 mL of 1 mol/L hydrochloric acid TS, and add water to make exactly 100 mL. Pipet 5 mL of this solution, add 0.02 mol/L hydrochloric acid TS to make exactly 50 mL, and use this solution as the standard solution. Perform the test with exactly 10 μL each of the sample solution and standard solution as directed under Liquid Chromatography <2.01> according to the following conditions: 13 peaks of amino acids appear on the chromatogram obtained from the sample solution, and their respective molar ratios with respect to leucine (=5) are 1.9 – 2.3 for lysine, 0.8 – 1.1 for histidine, 0.9 – 1.1 for arginine, 1.9 – 2.1 for aspartic acid, 4.5 – 4.9 for threonine, 3.2 – 3.8 for serine, 2.8 – 3.1 for glutamic acid, 1.9 – 2.4 for proline, 2.7 – 3.3 for glycine, 1.5 – 2.5 for 1/2 cystine, 0.9 – 1.0 for valine, and 0.8 – 1.0 for tyrosine.

Operating conditions—

Detector: A visible spectrophotometer (wavelength: 440 nm and 570 nm).

Column: A stainless steel column 4.6 mm in inside diameter and 6 cm in length, packed with strongly acidic ion-exchange resin for liquid chromatography (Na type) composed with a sulfonated polystyrene copolymer (3 μm in particle diameter).

Column temperature: A constant temperature of about 57°C.

Chemical reaction bath temperature: A constant temperature of about 130°C.

Color developing time: About 1 minute.

Mobile phase: Prepare mobile phases A, B, C, D and E according to the following table.

	Mobile phase A	Mobile phase B	Mobile phase C	Mobile phase D	Mobile phase E
Citric acid monohydrate	19.80 g	22.00 g	12.80 g	6.10 g	—
Trisodium citrate dihydrate	6.19 g	7.74 g	13.31 g	26.67 g	—
Sodium hydroxide	—	—	—	—	8.00 g
Sodium chloride	5.66 g	7.07 g	3.74 g	54.35 g	—
Ethanol (99.5)	130.0 mL	20.0 mL	4.0 mL	—	100.0 mL
Benzyl alcohol	—	—	—	5.0 mL	—
Thiodiglycol	5.0 mL	5.0 mL	5.0 mL	—	—
Lauromacrogol solution (1 in 4)	4.0 mL	4.0 mL	4.0 mL	4.0 mL	4.0 mL
Caprylic acid	0.1 mL	0.1 mL	0.1 mL	0.1 mL	0.1 mL
Water	a sufficient amount	a sufficient amount	a sufficient amount	a sufficient amount	a sufficient amount
Total volume	1000 mL	1000 mL	1000 mL	1000 mL	1000 mL

Flowing of mobile phase: Control the gradient by mixing the mobile phases A, B, C, D and E as directed in the following table.

Time after injection of sample (min)	Mobile phase A (vol%)	Mobile phase B (vol%)	Mobile phase C (vol%)	Mobile phase D (vol%)	Mobile phase E (vol%)
0 – 1.5	100	0	0	0	0
1.5 – 4	0	100	0	0	0
4 – 12	0	0	100	0	0
12 – 26	0	0	0	100	0
26 – 30	0	0	0	0	100

Reaction reagent: Mix 407 g of lithium acetate dihydrate, 245 mL of acetic acid (100) and 801 mL of 1-methoxy-2-propanol, add water to make 2000 mL, stir for 10 minutes while passing nitrogen, and use this solution as solution A. Separately, to 1957 mL of 1-methoxy-2-propanol add 77 g of ninhydrin and 0.134 g of sodium borohydride, stir for 30 minutes while passing nitrogen, and use this solution as solution B. Mix solution A and solution B before use.

Flow rate of mobile phase: About 0.4 mL per minute.

Flow rate of reaction reagent: About 0.35 mL per minute.

System suitability—

System performance: When the procedure is run with 10 μ L of the standard solution under the above operating conditions, aspartic acid, threonine, serine, glutamic acid, proline, glycine, alanine, cystine, valine, methionine, isoleucine, leucine, tyrosine, phenylalanine, lysine, histidine and arginine are eluted in this order with the resolutions between the peaks of threonine and serine, glycine and alanine, and isoleucine and leucine being not less than 1.2, 1.0 and 1.2, respectively.

System repeatability: When the test is repeated 3 times with 10 μ L of the standard solution under the above operating conditions, the relative standard deviations of the peak areas of aspartic acid, proline, valine and arginine are not more than 2.0%, respectively.

Peptide content Calculate the peptide content in Calcitonin Salmon by the following equation using amino acid analysis values (μ mol/mL) obtained in the Constituent amino acids: it is not less than 80.0%.

$$\text{Peptide content (\%)} = 3431.85 \times 5/M \times A/11 \times 100$$

A: Total (μ mol/mL) of the amino acid analysis values of valine, leucine, glycine and proline

M: Amount (μ g) of Calcitonin Salmon taken

11: Total of the theoretical residue numbers of valine, leucine, glycine and proline per one mole of calcitonin salmon

Purity (1) Acetic acid—Weigh accurately about 10 mg of Calcitonin Salmon, dissolve in water to make exactly 10 mL, and use this solution as the sample solution. Separately, weigh accurately about 1 g of acetic acid (100), and dissolve in water to make exactly 100 mL. Pipet 2 mL of this solution, add water to make exactly 200 mL, and use this solution as the standard solution. Perform the test with exactly 100 μ L each of the sample solution and standard solution as directed under Liquid Chromatography <2.01> according to the following conditions. Determine the peak areas, A_T and A_S , of acetic acid in each solution, and calculate the amount of acetic acid by the following equation: the amount of acetic acid is not more than 7.0%.

$$\begin{aligned} \text{Amount (\%)} \text{ of acetic acid (CH}_3\text{COOH)} \\ = M_S/M_T \times A_T/A_S \times 1/10 \end{aligned}$$

M_S : Amount (mg) of acetic acid (100) taken

M_T : Amount (mg) of Calcitonin Salmon taken

Operating conditions—

Detector: An ultraviolet absorption photometer (wavelength: 210 nm).

Column: A stainless steel column 4.6 mm in inside diameter and 25 cm in length, packed with octadecylsilanized silica gel for liquid chromatography (5 μ m in particle diameter).

Column temperature: A constant temperature of about 40°C.

Mobile phase A: To 0.7 mL of phosphoric acid add 900 mL of water, adjust the pH to 3.0 with 8 mol/L sodium hydroxide TS, and add water to make 1000 mL.

Mobile phase B: Methanol.

Flowing of mobile phase: Control the gradient by mixing the mobile phases A and B as directed in the following table.

Time after injection of sample (min)	Mobile phase A (vol%)	Mobile phase B (vol%)
0 – 5	95	5
5 – 10	95 → 50	5 → 50
10 – 20	50	50
20 – 22	50 → 95	50 → 5
22 – 30	95	5

Flow rate: Adjust so that the retention time of acetic acid is about 4 minutes.

System suitability—

System performance: When the procedure is run with 100 μ L of the standard solution under the above operating conditions, the number of theoretical plates and the symmetry factor of the peak of acetic acid are not less than 3000 and not more than 2.0, respectively.

System repeatability: When the test is repeated 6 times with 100 μ L of the standard solution under the above operating conditions, the relative standard deviation of the peak areas of acetic acid is not more than 2.0%.

(2) Related substances—Dissolve 2 mg of Calcitonin Salmon in 2 mL of dilute acetic acid, and use this solution as the sample solution. Perform the test with 20 μ L of the sample solution as directed under Liquid Chromatography

<2.01> according to the following conditions. Determine each peak area from the sample solution by the automatic integration method, and calculate the amount of them by the area percentage method: the total amount of the peaks other than calcitonin salmon is not more than 3%.

Operating conditions—

Detector: An ultraviolet absorption photometer (wavelength: 210 nm).

Column: A stainless steel column 3.9 mm in inside diameter and 30 cm in length, packed with octadecylsilanized silica gel for liquid chromatography (10 μ m in particle diameter).

Column temperature: A constant temperature of about 25°C.

Mobile phase: A mixture of 1% trimethylamine-phosphate buffer solution (pH 3.0) and acetonitrile (27:13).

Flow rate: Adjust so that the retention time of calcitonin salmon is about 9 minutes.

Time span of measurement: About 2 times as long as the retention time of calcitonin salmon, beginning after the solvent peak.

System suitability—

Test for required detectability: To 1 mL of the sample solution add the mobile phase to make 100 mL, and use this solution as the solution for system suitability test. Pipet 1 mL of the solution for system suitability test, and add the mobile phase to make exactly 10 mL. Confirm that the peak area of calcitonin salmon obtained with 20 μ L of this solution is equivalent to 5 to 15% of that with 20 μ L of the solution for system suitability test.

System performance: Dissolve 5 mg of methyl parahydroxybenzoate and 7 mg of ethyl parahydroxybenzoate in 100 mL of acetonitrile. When the procedure is run with 20 μ L of this solution under the above operating conditions methyl parahydroxybenzoate and ethyl parahydroxybenzoate are eluted in this order with the resolution between these peaks being not less than 5.

System repeatability: When the test is repeated 6 times with 20 μ L of the solution for system suitability test under the above operating conditions, the relative standard deviation of the peak areas of calcitonin salmon is not more than 2.0%.

Water <2.48> Not more than 10.0% (5 mg, coulometric titration).

Assay (i) **Test animals:** Select healthy albino rats weighing between 55 and 180 g, fasted for 24 hours before the test but allowed to drink water ad libitum.

(ii) **Standard solutions:** Dissolve a quantity of Calcitonin Salmon RS in acetic acid buffer solution containing 0.1% bovine serum albumin, and prepare a high-dose standard solution S_H and a low-dose standard solution S_L containing exactly 0.050 and 0.025 Units per mL, respectively.

(iii) **Sample solutions:** According to the labeled units, weigh accurately a suitable amount of Calcitonin Salmon, and dissolve in acetic acid buffer solution containing 0.1% bovine serum albumin, and prepare a high-dose sample solution T_H and the low-dose sample solution T_L having Units equal to the standard solutions in equal volumes, respectively.

(iv) **Dose for injection:** Inject 0.3 mL per animal.

(v) **Procedure:** Divide the test animals at random into 4 groups, A, B, C and D, with not less than 8 animals and equal numbers in each group. Inject S_H , S_L , T_H and T_L into the tail vein or subcutaneously into the neck of each animal of the respective groups. At 1 hour after the injection, collect blood from the abdominal aorta in a way that minimizes the suffering of the animals, allow the blood samples to stand

at room temperature for about 30 minutes, and centrifuge at 3000 revolutions per minute for 10 minutes to separate serum.

(vi) **Serum calcium determination:** Pipet 0.1 mL of the serum, add exactly 6.9 mL of strontium TS, mix well, and use this solution as the sample solution for calcium determination. Separately, pipet a suitable volume of Standard Calcium Solution for Atomic Absorption Spectrophotometry, dissolve in strontium TS to make a solution so that each mL contains 0.2 to 3 μ g of calcium (Ca: 40.08), and use this solution as the standard solution for calcium determination. Perform the test as directed under Atomic Absorption Spectrometry <2.23> according to the following conditions, and calculate the calcium content of the sample solution for calcium determination from the calibration curve obtained from the absorbance of the standard solution for calcium determination.

$$\begin{aligned} \text{Amount (mg) of Calcium (Ca) in 100 mL of the serum} \\ = \text{Calcium content (ppm) in the sample solution for} \\ \text{calcium determination} \times 7 \end{aligned}$$

Gas: Combustible gas—Acetylene.

Supporting gas—Air.

Lamp: Calcium hollow-cathode lamp.

Wavelength: 422.7 nm.

(vii) **Calculation:** Amounts of calcium in the serum obtained with S_H , S_L , T_H and T_L are symbolized as y_1 , y_2 , y_3 and y_4 , respectively. Sum up y_1 , y_2 , y_3 and y_4 on each set to obtain Y_1 , Y_2 , Y_3 and Y_4 , respectively.

$$\text{Units per mg of peptide} = \text{antilog } M \times b/a \times 1/c \times 5$$

$$M = 0.3010 \times (Y_a/Y_b)$$

$$Y_a = -Y_1 - Y_2 + Y_3 + Y_4$$

$$Y_b = Y_1 - Y_2 + Y_3 - Y_4$$

a: Amount (mg) of Calcitonin Salmon taken

b: Total volume (mL) of the high-dose sample solution prepared by dissolving Calcitonin Salmon in acetic acid buffer solution containing 0.1% bovine serum albumin.

c: Peptide content (%)

F' computed by the following equation should be smaller than F_1 shown in the table against n with which s^2 is calculated. Calculate L ($P = 0.95$) by use of the following equation: L should be not more than 0.20. If F' exceeds F_1 , or if L exceeds 0.20, repeat the test, increasing the number of animals or arranging the assay conditions so that F' is not more than F_1 and L is not more than 0.20.

$$F' = (-Y_1 + Y_2 + Y_3 - Y_4)^2/4fs^2$$

f: Number of the test animals of each group.

$$s^2 = \{\sum y^2 - (Y/f)\}/n$$

$\sum y^2$: The sum of squares of y_1 , y_2 , y_3 and y_4 in each group.

$$Y = Y_1^2 + Y_2^2 + Y_3^2 + Y_4^2$$

$$n = 4(f - 1)$$

$$L = 2\sqrt{(C - 1)(CM^2 + 0.09062)}$$

$$C = Y_b^2/(Y_b^2 - 4fs^2t^2)$$

t^2 : Value shown in the following table against n used to calculate s^2 .

<i>n</i>	$t^2 = F_1$	<i>n</i>	$t^2 = F_1$	<i>n</i>	$t^2 = F_1$
1	161.45	13	4.667	25	4.242
2	18.51	14	4.600	26	4.225
3	10.129	15	4.543	27	4.210
4	7.709	16	4.494	28	4.196
5	6.608	17	4.451	29	4.183
6	5.987	18	4.414	30	4.171
7	5.591	19	4.381	40	4.085
8	5.318	20	4.351	60	4.001
9	5.117	21	4.325	120	3.920
10	4.965	22	4.301	∞	3.841
11	4.844	23	4.279		
12	4.747	24	4.260		

Containers and storage Containers—Hermetic containers.
Storage—Light-resistant, not exceeding 10°C.

Precipitated Calcium Carbonate

沈降炭酸カルシウム

CaCO₃: 100.09

Precipitated Calcium Carbonate, when dried, contains not less than 98.5% of calcium carbonate (CaCO₃).

Description Precipitated Calcium Carbonate occurs as a white, fine crystalline powder. It is odorless and tasteless.

It is practically insoluble in water, but its solubility in water is increased in the presence of carbon dioxide.

It is practically insoluble in ethanol (95) and in diethyl ether.

It dissolves with effervescence in dilute acetic acid, in dilute hydrochloric acid and in dilute nitric acid.

Identification (1) Dissolve 0.5 g of Precipitated Calcium Carbonate in 10 mL of dilute hydrochloric acid, boil, then cool, and neutralize with ammonia TS: the solution responds to Qualitative Tests <1.09> for calcium salt.

(2) Precipitated Calcium Carbonate responds to Qualitative Tests <1.09> (1) for carbonate.

Purity (1) Acid-insoluble substances—To 5.0 g of Precipitated Calcium Carbonate add 50 mL of water, then add 20 mL of hydrochloric acid dropwise with stirring, boil for 5 minutes, cool, add water to make 200 mL, and filter through filter paper for quantitative analysis. Wash the residue until the last washing shows no turbidity with silver nitrate TS, and ignite the residue together with the filter paper: the mass of the residue is not more than 10.0 mg.

(2) Heavy metals <1.07>—Mix 2.0 g of Precipitated Calcium Carbonate with 5 mL of water, add slowly 6 mL of dilute hydrochloric acid, and evaporate on a water bath to dryness. Dissolve the residue in 50 mL of water, and filter. To 25 mL of the filtrate add 2 mL of dilute acetic acid, 1 drop of ammonia TS and water to make 50 mL, and perform the test using this solution as the test solution. Prepare the control solution as follows: evaporate 3 mL of hydrochloric acid on a water bath to dryness, and add 2.0 mL of Standard Lead Solution, 2 mL of dilute acetic acid and water to make 50 mL (not more than 20 ppm).

(3) Barium—Mix 1.0 g of Precipitated Calcium Carbonate with 10 mL of water, add dropwise 4 mL of hydrochloric acid with stirring, boil for 5 minutes, cool, add water to make 40 mL, and filter. With the filtrate, perform the test

as directed under Flame Coloration Test <1.04> (1): no green color appears.

(4) Magnesium and alkali metals—Dissolve 1.0 g of Precipitated Calcium Carbonate in a mixture of 20 mL of water and 10 mL of dilute hydrochloric acid, boil, neutralize with ammonia TS, and add ammonium oxalate TS until precipitation of calcium oxalate is completed. Heat the mixture on a water bath for 1 hour, cool, dilute with water to 100 mL, shake well, and filter. To 50 mL of the filtrate add 0.5 mL of sulfuric acid, evaporate to dryness, and ignite at 600°C to constant mass: the mass of the residue is not more than 5.0 mg.

(5) Arsenic <1.11>—Moisten 0.40 g of Precipitated Calcium Carbonate with 1 mL of water, then dissolve in 4 mL of dilute hydrochloric acid, use this solution as the test solution, and perform the test (not more than 5 ppm).

Loss on drying <2.41> Not more than 1.0% (1 g, 180°C, 4 hours).

Assay Weigh accurately about 0.12 g of Precipitated Calcium Carbonate, previously dried, and dissolve in 20 mL of water and 3 mL of dilute hydrochloric acid. Add 80 mL of water, 15 mL of a solution of potassium hydroxide (1 in 10) and 0.05 g of NN indicator, and titrate <2.50> immediately with 0.05 mol/L disodium dihydrogen ethylenediamine tetraacetate VS until the color of the solution changes from red-purple to blue.

Each mL of 0.05 mol/L disodium dihydrogen ethylenediamine tetraacetate VS
= 5.005 mg of CaCO₃

Containers and storage Containers—Tight containers.

Precipitated Calcium Carbonate Fine Granules

沈降炭酸カルシウム細粒

Precipitated Calcium Carbonate Fine Granules contain not less than 95.0% and not more than 105.0% of the labeled amount of calcium carbonate (CaCO₃: 100.09).

Method of preparation Prepare as directed under Granules, with Precipitated Calcium Carbonate.

Identification (1) To a quantity of powdered Precipitated Calcium Carbonate Fine Granules, equivalent to 0.5 g of Precipitated Calcium Carbonate, add 10 mL of dilute hydrochloric acid, shake thoroughly, and filter. Boil the filtrate, then cool, and neutralize with ammonia TS: the solution responds to Qualitative Tests <1.09> (1), (2) and (3) for calcium salt.

(2) Powdered Precipitated Calcium Carbonate Fine Granules responds to Qualitative Tests <1.09> (1) for carbonate.

Uniformity of dosage units <6.02> The granules in single-dose packages meet the requirement of the Mass variation test.

Dissolution <6.10> When the test is performed at 50 revolutions per minute according to the Paddle method, using 900 mL of 1st fluid for dissolution test as the dissolution medium, the dissolution rate in 10 minutes of Precipitated Calcium Carbonate Fine Granules is not less than 80%.

Start the test with an accurately weighed amount of

Precipitated Calcium Carbonate Fine Granules, equivalent to about 0.5 g of calcium carbonate (CaCO_3), withdraw not less than 20 mL of the medium at the specified minute after starting the test, and filter through a membrane filter with a pore size not exceeding $0.45\ \mu\text{m}$. Discard not less than 10 mL of the first filtrate, pipet 2 mL of the subsequent filtrate, add the mobile phase to make exactly 20 mL, and use this solution as the sample solution. Separately, weigh accurately about 28 mg of calcium carbonate for assay, previously dried at 180°C for 4 hours, and dissolve in the dissolution medium to make exactly 100 mL. Pipet 10 mL of this solution, add the mobile phase to make exactly 50 mL, and use this solution as the standard solution. Perform the test with exactly $20\ \mu\text{L}$ each of the sample solution and standard solution as directed under Liquid Chromatography <2.01> according to the following conditions, and determine the peak areas, A_T and A_S , of calcium in each solution.

Dissolution rate (%) with respect to the labeled amount of calcium carbonate (CaCO_3)

$$= M_S/M_T \times A_T/A_S \times 1/C \times 1800$$

M_S : Amount (mg) of calcium carbonate for assay taken

M_T : Amount (mg) of Precipitated Calcium Carbonate Fine Granules taken

C: Labeled amount (mg) of calcium carbonate (CaCO_3) in 1 g

Operating conditions—

Detector: An electric conductivity detector.

Column: A polyether ether ketone tube 4.6 mm in inside diameter and 10 cm in length, packed with slightly acidic ion-exchange silica gel for liquid chromatography ($7\ \mu\text{m}$ in particle diameter).

Column temperature: A constant temperature of about 40°C .

Mobile phase: A mixture of a solution of tartaric acid (3 in 2000) and a solution of dipicolinic acid (1 in 3000) (1:1).

Flow rate: Adjust so that the retention time of calcium is about 8 minutes.

System suitability—

System performance: When the procedure is run with $20\ \mu\text{L}$ of the standard solution under the above operating conditions, sodium and calcium are eluted in this order with the resolution between these peaks being not less than 4.5.

System repeatability: When the test is repeated 5 times with $20\ \mu\text{L}$ of the standard solution under the above operating conditions, the relative standard deviation of the peak area of calcium is not more than 2.0%.

Assay Weigh accurately a quantity of powdered Precipitated Calcium Carbonate Fine Granules, equivalent to about 0.12 g of calcium carbonate (CaCO_3), add 20 mL of water and 3 mL of dilute hydrochloric acid, and agitate for 15 minutes with the aid of ultrasonic waves. Then, add 80 mL of water, 15 mL of a solution of potassium hydroxide (1 in 10) and 50 mg of NN indicator, and titrate <2.50> immediately with 0.05 mol/L disodium dihydrogen ethylenediamine tetraacetate VS until the color of the solution changes from red-purple to blue.

Each mL of 0.05 mol/L disodium dihydrogen ethylenediamine tetraacetate VS
= 5.005 mg of CaCO_3

Containers and storage Containers—Well-closed containers.

Precipitated Calcium Carbonate Tablets

沈降炭酸カルシウム錠

Precipitated Calcium Carbonate Tablets contain not less than 95.0% and not more than 105.0% of the labeled amount of calcium carbonate (CaCO_3 : 100.09).

Method of preparation Prepare as directed under Tablets, with Precipitated Calcium Carbonate.

Identification (1) To a quantity of powdered Precipitated Calcium Carbonate Tablets, equivalent to 0.5 g of Precipitated Calcium Carbonate, add 10 mL of dilute hydrochloric acid, shake thoroughly, and filter, if necessary. Boil, then cool, and neutralize with ammonia TS: the solution responds to Qualitative Tests <1.09> (1), (2) and (3) for calcium salt.

(2) Powdered Precipitated Calcium Carbonate Tablets responds to Qualitative Tests <1.09> (1) for carbonate.

Uniformity of dosage units <6.02> It meets the requirement of the Mass variation test.

Disintegration <6.09> Apply to the preparation intended to be used as antacid.

Perform the test using the disk: it meets the requirement.

Dissolution <6.10> Apply to the preparation intended to be used as hyperphosphatemia.

When the test is performed at 50 revolutions per minute according to the Paddle method, using 900 mL of 1st fluid for dissolution test as the dissolution medium, the dissolution rate in 10 minutes of Precipitated Calcium Carbonate Tablets is not less than 80%.

Start the test with 1 tablet of Precipitated Calcium Carbonate Tablets, withdraw not less than 20 mL of the medium at the specified minute after starting the test, and filter through a membrane filter with a pore size not exceeding $0.45\ \mu\text{m}$. Discard not less than 10 mL of the first filtrate, pipet V mL of the subsequent filtrate, add the mobile phase to make exactly V' mL so that each mL contains about $56\ \mu\text{g}$ of calcium carbonate (CaCO_3), and use this solution as the sample solution. Separately, weigh accurately about 28 mg of calcium carbonate for assay, previously dried at 180°C for 4 hours, and dissolve in the dissolution medium to make exactly 100 mL. Pipet 10 mL of this solution, add the mobile phase to make exactly 50 mL, and use this solution as the standard solution. Perform the test with exactly $20\ \mu\text{L}$ each of the sample solution and standard solution as directed under Liquid Chromatography <2.01> according to the following conditions, and determine the peak areas, A_T and A_S , of calcium in each solution.

Dissolution rate (%) with respect to the labeled amount of calcium carbonate (CaCO_3)

$$= M_S \times A_T/A_S \times V'/V \times 1/C \times 180$$

M_S : Amount (mg) of calcium carbonate for assay taken

C: Labeled amount (mg) of calcium carbonate (CaCO_3) in 1 tablet

Operating conditions—

Detector: An electric conductivity detector.

Column: A polyether ether ketone tube 4.6 mm in inside diameter and 10 cm in length, packed with slightly acidic ion-exchange silica gel for liquid chromatography ($7\ \mu\text{m}$ in particle diameter).

Column temperature: A constant temperature of about 40°C.

Mobile phase: A mixture of a solution of tartaric acid (3 in 2000) and a solution of dipicolinic acid (1 in 3000) (1:1).

Flow rate: Adjust so that the retention time of calcium is about 8 minutes.

System suitability—

System performance: When the procedure is run with 20 µL of the standard solution under the above operating conditions, sodium and calcium are eluted in this order with the resolution between these peaks being not less than 4.5.

System repeatability: When the test is repeated 5 times with 20 µL of the standard solution under the above operating conditions, the relative standard deviation of the peak area of calcium is not more than 2.0%.

Acid-neutralizing capacity <6.04> Apply to the preparation intended to be used as antacid.

Weigh accurately and powder not less than 40 Precipitated Calcium Carbonate Tablets. Perform the test with an accurately weighed amount of the powder, equivalent to about 0.25 g of Calcium Carbonate: the amount of 0.1 mol/L hydrochloric acid VS consumed per 1 g of Precipitated Calcium Carbonate is not less than 190 mL.

Assay Weigh accurately and powder not less than 20 Precipitated Calcium Carbonate Tablets. To an accurately weighed portion of the powder, equivalent to about 0.12 g of calcium carbonate (CaCO₃), add 20 mL of water, 3 mL of dilute hydrochloric acid, and agitate, if necessary, for 15 minutes with the aid of ultrasonic waves. Then, add 80 mL of water, 15 mL of a solution of potassium hydroxide (1 in 10) and 50 mg of NN indicator, and titrate <2.50> immediately with 0.05 mol/L disodium dihydrogen ethylenediamine tetraacetate VS until the color of the solution changes from red-purple to blue.

Each mL of 0.05 mol/L disodium dihydrogen ethylenediamine tetraacetate VS
= 5.005 mg of CaCO₃

Containers and storage Containers—Tight containers.

Calcium Chloride Hydrate

塩化カルシウム水和物

CaCl₂·2H₂O: 147.01

Calcium Chloride Hydrate contains not less than 96.7% and not more than 103.3% of calcium chloride hydrate (CaCl₂·2H₂O).

Description Calcium Chloride Hydrate occurs as white, granules or masses. It is odorless.

It is very soluble in water, and soluble in ethanol (95), and practically insoluble in diethyl ether.

It is deliquescent.

Identification A solution of Calcium Chloride Hydrate (1 in 10) responds to Qualitative Tests <1.09> for calcium salt and for chloride.

pH <2.54> The pH of a solution of 1.0 g of Calcium Chloride Hydrate in 20 mL of freshly boiled and cooled water is between 4.5 and 9.2.

Purity (1) Clarity and color of solution—A solution of 1.0 g of Calcium Chloride Hydrate in 20 mL of water is clear

and colorless.

(2) Sulfate <1.14>—Take 1.0 g of Calcium Chloride Hydrate, and perform the test. Prepare the control solution with 0.50 mL of 0.005 mol/L sulfuric acid VS (not more than 0.024%).

(3) Hypochlorite—Dissolve 0.5 g of Calcium Chloride Hydrate in 5 mL of water, add 2 to 3 drops of dilute hydrochloric acid and 2 to 3 drops of zinc iodide-starch TS: no blue color develops immediately.

(4) Heavy metals <1.07>—Proceed with 2.0 g of Calcium Chloride Hydrate according to Method 1, and perform the test. Prepare the control solution with 2.0 mL of Standard Lead Solution (not more than 10 ppm).

(5) Iron, aluminum or phosphate—Dissolve, in a Nessler tube, 1.0 g of Calcium Chloride Hydrate in 20 mL of water and 1 drop of dilute hydrochloric acid, boil, then cool, add 3 drops of ammonia TS, and heat the solution to boil: no turbidity or precipitate is produced.

(6) Barium—Dissolve 0.5 g of Calcium Chloride Hydrate in 5 mL of water, add 2 drops of dilute hydrochloric acid and 2 mL of potassium sulfate TS, and allow to stand for 10 minutes: no turbidity is produced.

(7) Arsenic <1.11>—Prepare the test solution with 1.0 g of Calcium Chloride Hydrate according to Method 1, and perform the test (not more than 2 ppm).

Assay Weigh accurately about 0.4 g of Calcium Chloride Hydrate, and dissolve in water to make exactly 200 mL. Measure exactly 20 mL of this solution, add 40 mL of water, 2 mL of 8 mol/L potassium hydroxide TS and 0.1 g of NN indicator, and titrate <2.50> immediately with 0.02 mol/L disodium dihydrogen ethylenediamine tetraacetate VS until the color of the solution changes from red-purple to blue.

Each mL of 0.02 mol/L disodium dihydrogen ethylenediamine tetraacetate VS
= 2.940 mg of CaCl₂·2H₂O

Containers and storage Containers—Tight containers.

Calcium Chloride Injection

塩化カルシウム注射液

Calcium Chloride Injection is an aqueous injection.

It contains not less than 95.0% and not more than 105.0% of the labeled amount of calcium chloride (CaCl₂: 110.98).

The concentration of Calcium Chloride Injection is expressed as the quantity of calcium chloride (CaCl₂).

Method of preparation Prepare as directed under Injection, with Calcium Chloride Hydrate.

Description Calcium Chloride Injection is a clear, colorless liquid.

Identification Calcium Chloride Injection responds to Qualitative Tests <1.09> for calcium salt and for chloride.

pH <2.54> 4.5 – 7.5

Bacterial endotoxins <4.01> Less than 0.30 EU/mg.

Extractable volume <6.05> It meets the requirement.

Foreign insoluble matter <6.06> Perform the test according to Method 1: it meets the requirement.

Insoluble particulate matter <6.07> It meets the requirement.

Sterility <4.06> Perform the test according to the Membrane filtration method: it meets the requirement.

Assay Measure exactly a volume of Calcium Chloride Injection, equivalent to about 0.4 g of calcium chloride (CaCl₂), and proceed as directed in the Assay under Calcium Chloride Hydrate.

Each mL of 0.02 mol/L disodium dihydrogen ethylenediamine tetraacetate VS
= 2.220 mg of CaCl₂

Containers and storage Containers—Hermetic containers. Plastic containers for aqueous injections may be used.

Calcium Folate Hydrate

Calcium Folate

Calcium Leucovorin

ホリナートカルシウム水和物

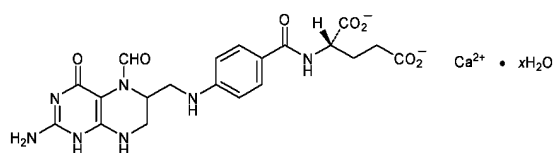

C₂₀H₂₁CaN₇O₇·xH₂O

Monocalcium *N*-(4-[[[2-amino-5-formyl-4-oxo-1,4,5,6,7,8-hexahydropteridin-6-yl)methyl]amino]benzoyl)-L-glutamate hydrate

[1492-18-8, anhydride]

Calcium Folate Hydrate contains not less than 95.0% and not more than 102.0% of calcium folinate (C₂₀H₂₁CaN₇O₇), calculated on the anhydrous basis.

Description Calcium Folate Hydrate occurs as a white to light yellow crystalline powder.

It is sparingly soluble in water, and practically insoluble in methanol and in ethanol (99.5).

Identification (1) Determine the absorption spectrum of a solution of Calcium Folate Hydrate (1 in 100,000) as directed under Ultraviolet-visible Spectrophotometry <2.24>, and compare the spectrum with the Reference Spectrum or the spectrum of a solution of Calcium Folate Hydrate RS prepared in the same manner as the sample solution: both spectra exhibit similar intensities of absorption at the same wavelengths.

(2) Determine the infrared absorption spectrum of Calcium Folate Hydrate as directed in the potassium bromide disk method under Infrared Spectrophotometry <2.25>, and compare the spectrum with the Reference Spectrum: both spectra exhibit similar intensities of absorption at the same wave numbers.

(3) A solution of Calcium Folate Hydrate (1 in 100) responds to Qualitative Tests <1.09> (2) and (3) for calcium salt.

Optical rotation <2.49> [α]_D²⁰: +14 – +19° (0.1 g calculated on the anhydrous basis, water, 10 mL, 100 mm).

pH <2.54> To 1.25 g of Calcium Folate Hydrate add 50 mL of freshly boiled and cooled water, and warm to 40°C, if necessary, to dissolve: the pH of this solution is between 6.8 and 8.0.

Purity (1) Clarity and color of solution—To 1.25 g of Calcium Folate Hydrate add 50 mL of freshly boiled and cooled water, and warm to 40°C, if necessary, to dissolve: the solution is clear, and the absorbance at 420 nm of it, determined as directed under Ultraviolet-visible Spectrophotometry <2.24>, is not more than 0.25.

(2) Heavy metals <1.07>—Proceed with 0.40 g of Calcium Folate Hydrate according to Method 2, and perform the test. Prepare the control solution with 2.0 mL of Standard Lead Solution (not more than 50 ppm).

(3) Related substances—Dissolve 10 mg of Calcium Folate Hydrate in 25 mL of water, and use this solution as the sample solution. Pipet 2 mL of the sample solution, add water to make exactly 200 mL, and use this solution as the standard solution. Perform the test with exactly 20 μL each of the sample solution and standard solution as directed under Liquid Chromatography <2.01> according to the following conditions, and determine each peak area by the automatic integration method: the area of the peak other than folinate obtained from the sample solution is not larger than the peak area of folinate from the standard solution, and the total area of the peaks other than folinate from the sample solution is not larger than 5 times the peak area of folinate from the standard solution.

Operating conditions—

Detector, column, column temperature, mobile phase, and flow rate: Proceed as directed in the operating conditions in the Assay.

Time span of measurement: About 2.5 times as long as the retention time of folinate, beginning after the solvent peak.

System suitability—

System performance: Proceed as directed in the system suitability in the Assay.

Test for required detectability: Pipet 5 mL of the standard solution, and add water to make exactly 50 mL. Confirm that the peak area of folinate obtained with 20 μL of this solution is equivalent to 7 to 13% of that with 20 μL of the standard solution.

System repeatability: When the test is repeated 6 times with 20 μL of the standard solution under the above operating conditions, the relative standard deviation of the peak area of folinate is not more than 2.0%.

Water <2.48> Not less than 7.0% and not more than 17.0% (0.2 g, volumetric titration, direct titration).

Assay Weigh accurately about 10 mg each of Calcium Folate Hydrate and Calcium Folate Hydrate RS (separately determine the water <2.48> in the same manner as Calcium Folate Hydrate), dissolve in water to make them exactly 25 mL. Pipet 5 mL each of these solutions, add the mobile phase to make exactly 25 mL, and use these solutions as the sample solution and the standard solution, respectively. Perform the test with exactly 20 μL each of the sample solution and standard solution as directed under Liquid Chromatography <2.01> according to the following conditions, and determine the peak areas, A_T and A_S, of folinate in each solution.

$$\begin{aligned} \text{Amount (mg) of calcium folinate (C}_{20}\text{H}_{21}\text{CaN}_7\text{O}_7) \\ = M_S \times A_T/A_S \end{aligned}$$

M_S: Amount (mg) of Calcium Folate Hydrate RS taken, calculated on the anhydrous basis

Operating conditions—

Detector: An ultraviolet absorption photometer (wavelength: 254 nm).

Column: A stainless steel column 4.6 mm in inside diame-

ter and 15 cm in length, packed with octadecylsilanized silica gel for liquid chromatography (5 μ m in particle diameter).

Column temperature: A constant temperature of about 45°C.

Mobile phase: A mixture of disodium hydrogen phosphate dodecahydrate solution (287 in 100,000), methanol and tetrabutylammonium hydroxide TS (385:110:4), adjusted to pH7.5 with phosphoric acid.

Flow rate: Adjust so that the retention time of folinate is about 10 minutes.

System suitability—

System performance: Dissolve 10 mg each of Calcium Folate Hydrate and folic acid in 100 mL of the mobile phase. When the procedure is run with 20 μ L of this solution under the above operating conditions, folinate and folic acid are eluted in this order with the resolution between these peaks being not less than 10.

System repeatability: When the test is repeated 6 times with 20 μ L of the standard solution under the above operating conditions, the relative standard deviation of the peak area of folinate is not more than 1.0%.

Containers and storage Containers—Tight containers.

Storage—Light-resistant.

Calcium Gluconate Hydrate

グルコン酸カルシウム水和物

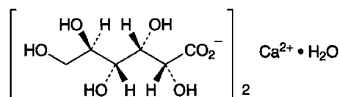

$C_{12}H_{22}CaO_{14} \cdot H_2O$: 448.39

Monocalcium di-D-gluconate monohydrate
[299-28-5]

Calcium Gluconate Hydrate, when dried, contains not less than 99.0% and not more than 104.0% of calcium gluconate hydrate ($C_{12}H_{22}CaO_{14} \cdot H_2O$).

Description Calcium Gluconate Hydrate occurs as a white, crystalline powder or granules.

It is soluble in water, and practically insoluble in ethanol (99.5).

Identification (1) To separately 10 mg each of Calcium Gluconate Hydrate and calcium gluconate for thin-layer chromatography add 1 mL of water, dissolve by warming, and use these solutions as the sample solution and the standard solution, respectively. Perform the test with these solutions as directed under Thin-layer Chromatography <2.03>. Spot 5 μ L each of the sample solution and standard solution on a plate of silica gel for thin-layer chromatography. Develop the plate with a mixture of ethanol (95), water, ammonia solution (28) and ethyl acetate (5:3:1:1) to a distance of about 10 cm, air-dry the plate, and heat the plate at 110°C for 20 minutes. After cooling, spray evenly hexaammonium heptamolybdate-cerium (IV) sulfate TS on the plate, air-dry, and heat at 110°C for 10 minutes: the spots with the sample solution and the standard solution are the same in the R_f value and color tone.

(2) A solution of Calcium Gluconate Hydrate (1 in 40) responds to Qualitative Tests <1.09> (1), (2) and (3) for calcium salt.

Optical rotation <2.49> $[\alpha]_D^{20}$: +6 – +11° (after drying, 0.5 g, water, warming, after cooling, 25 mL, 100 mm).

pH <2.54> Dissolve 1.0 g of Calcium Gluconate Hydrate in 20 mL of water by warming: the pH of the solution is between 6.0 and 8.0.

Purity (1) Clarity and color of solution—Dissolve 1.0 g of Calcium Gluconate Hydrate in 50 mL of water by warming: the solution is clear and colorless.

(2) Chloride <1.03>—Take 0.40 g of Calcium Gluconate Hydrate, and perform the test. Prepare the control solution with 0.80 mL of 0.01 mol/L hydrochloric acid VS (not more than 0.071%).

(3) Sulfate <1.14>—Take 1.0 g of Calcium Gluconate Hydrate, and perform the test. Prepare the control solution with 1.0 mL of 0.005 mol/L sulfuric acid VS (not more than 0.048%).

(4) Heavy metals <1.07>—Dissolve 1.0 g of Calcium Gluconate Hydrate in 30 mL of water and 2 mL of dilute acetic acid by warming, cool, and add water to make 50 mL. Perform the test using this solution as the test solution. Prepare the control solution with 2.0 mL of Standard Lead Solution, 2 mL of dilute acetic acid, and water to make 50 mL (not more than 20 ppm).

(5) Arsenic <1.11>—Dissolve 0.6 g of Calcium Gluconate Hydrate in 5 mL of water by warming, add 5 mL of dilute sulfuric acid and 1 mL of bromine TS, and concentrate on a water bath to 5 mL. Perform the test with this solution as the test solution (not more than 3.3 ppm).

(6) Sucrose and reducing sugars—To 0.5 g of Calcium Gluconate Hydrate add 10 mL of water and 2 mL of dilute hydrochloric acid, and boil the solution for 2 minutes. After cooling, add 5 mL of sodium carbonate TS, allow to stand for 5 minutes, add water to make 20 mL, and filter. To 5 mL of the filtrate add 2 mL of Fehling's TS, and boil for 1 minute: no orange-yellow to red precipitate is formed immediately.

Loss on drying <2.41> Not more than 1.0% (1 g, 80°C, 2 hours).

Assay Weigh accurately about 0.4 g of Calcium Gluconate Hydrate, previously dried, dissolve in 100 mL of water, add 2 mL of 8 mol/L potassium hydroxide TS and 0.1 g of NN indicator, and titrate <2.50> immediately with 0.05 mol/L disodium dihydrogen ethylenediamine tetraacetate VS until the color of the solution changes from red-purple to blue.

Each mL of 0.05 mol/L disodium dihydrogen ethylenediamine tetraacetate VS
= 22.42 mg of $C_{12}H_{22}CaO_{14} \cdot H_2O$

Containers and storage Containers—Well-closed containers.

Calcium Hydroxide

水酸化カルシウム

$Ca(OH)_2$: 74.09

Calcium Hydroxide contains not less than 90.0% of calcium hydrate [$Ca(OH)_2$].

Description Calcium Hydroxide occurs as a white powder. It has a slightly bitter taste.

It is slightly soluble in water, very slightly soluble in boiling water, and practically insoluble in ethanol (95) and in diethyl ether.

It dissolves in dilute acetic acid, in dilute hydrochloric acid

and in dilute nitric acid.

It absorbs carbon dioxide from air.

Identification (1) Mix Calcium Hydroxide with 3 to 4 times its mass of water: the mixture is slushy and is alkaline.

(2) Dissolve 1 g of Calcium Hydroxide in 30 mL of dilute acetic acid, and boil. After cooling, neutralize with ammonia TS: the solution responds to Qualitative tests <1.09> (2) and (3) for calcium salt.

Purity (1) Acid-insoluble substances—To 5 g of Calcium Hydroxide add 100 mL of water, add hydrochloric acid dropwise with stirring until the solution becomes acidic, and further add 1 mL of hydrochloric acid. Boil this solution for 5 minutes, cool, and filter through a tared glass filter (G4). Wash the residue with boiling water until the last washing exhibits no turbidity upon addition of silver nitrate TS, and dry at 105°C to constant mass: the mass is not more than 25 mg.

(2) Heavy metals <1.07>—Dissolve 1.0 g of Calcium Hydroxide in 10 mL of dilute hydrochloric acid, evaporate on a water bath to dryness, dissolve the residue in 40 mL of water, and filter. To 20 mL of the filtrate add 2 mL of dilute acetic acid and water to make 50 mL, and perform the test using this solution as the test solution. Prepare the control solution as follows: evaporate 5 mL of dilute hydrochloric acid on a water bath to dryness, and add 2 mL of dilute acetic acid, 2.0 mL of Standard Lead Solution and water to make 50 mL (not more than 40 ppm).

(3) Magnesium and alkali metals—Dissolve 1.0 g of Calcium Hydroxide in a mixture of 20 mL of water and 10 mL of dilute hydrochloric acid, boil, neutralize with ammonia TS, and precipitate calcium oxalate completely by adding dropwise ammonium oxalate TS. Heat the mixture on a water bath for 1 hour, cool, dilute with water to 100 mL, shake, and filter. To 50 mL of the filtrate add 0.5 mL of sulfuric acid, evaporate to dryness, and ignite at 600°C to constant mass: the mass of the residue does not exceed 24 mg.

(4) Arsenic <1.11>—Dissolve 0.5 g of Calcium Hydroxide in 5 mL of dilute hydrochloric acid, and perform the test with this solution as the test solution (not more than 4 ppm).

Assay Weigh accurately about 1 g of Calcium Hydroxide, dissolve by adding 10 mL of dilute hydrochloric acid, and add water to make exactly 100 mL. Measure exactly 10 mL of this solution, add 90 mL of water and 1.5 mL of 8 mol/L potassium hydroxide TS, shake, allow to stand for 3 to 5 minutes, and then add 0.1 g of NN indicator. Titrate <2.50> immediately with 0.05 mol/L disodium dihydrogen ethylenediamine tetraacetate VS, until the red-purple color of the solution changes to blue.

Each mL of 0.05 mol/L disodium dihydrogen ethylenediamine tetraacetate VS
= 3.705 mg of Ca(OH)₂

Containers and storage Containers—Tight containers.

Calcium Lactate Hydrate

乳酸カルシウム水和物

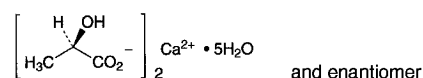

C₆H₁₀CaO₆·5H₂O: 308.29

Monocalcium bis[(2*RS*)-2-hydroxypropanoate] pentahydrate
[63690-56-2]

Calcium Lactate Hydrate, when dried, contains not less than 97.0% of calcium lactate (C₆H₁₀CaO₆: 218.22).

Description Calcium Lactate Hydrate occurs as white, powder or granules. It is odorless, and has a slightly acid taste.

A 1 g portion of it dissolves gradually in 20 mL of water, and it is slightly soluble in ethanol (95), and practically insoluble in diethyl ether.

It is partly efflorescent at ordinary temperature, and yields the anhydride at 120°C.

Identification A solution of Calcium Lactate Hydrate (1 in 20) responds to Qualitative Tests <1.09> for calcium salt and for lactate.

Purity (1) Clarity of solution—Dissolve 1.0 g of Calcium Lactate Hydrate in 20 mL of water by warming: the solution is clear.

(2) Acidity or alkalinity—To the solution obtained in (1) add 2 drops of phenolphthalein TS: no red color is produced. Then add 0.50 mL of 0.1 mol/L sodium hydroxide VS: a red color develops.

(3) Heavy metals <1.07>—Dissolve 1.0 g of Calcium Lactate Hydrate in 30 mL of water and 5 mL of dilute acetic acid by warming, cool, add water to make 50 mL, and perform the test using this solution as the test solution. Prepare the control solution from 2.0 mL of Standard Lead Solution and 2 mL of dilute acetic acid, and dilute with water to 50 mL (not more than 20 ppm).

(4) Magnesium or alkali metals—Dissolve 1.0 g of Calcium Lactate Hydrate in 40 mL of water, add 0.5 g of ammonium chloride, boil, then add 20 mL of ammonium oxalate TS. Heat the mixture on a water bath for 1 hour, cool, dilute with water to 100 mL, and filter. To 50 mL of the filtrate add 0.5 mL of sulfuric acid, evaporate to dryness, and ignite between 450°C and 550°C to constant mass: the mass of the residue is not more than 5 mg.

(5) Arsenic <1.11>—Dissolve 0.5 g of Calcium Lactate Hydrate in 2 mL of water and 3 mL of hydrochloric acid, and perform the test with this solution as the test solution (not more than 4 ppm).

(6) Volatile fatty acid—Warm 1.0 g of Calcium Lactate Hydrate with 2 mL of sulfuric acid: an odor of acetic acid or butyric acid is not perceptible.

Loss on drying <2.41> 25.0 – 30.0% (1 g, 80°C, 1 hour at first, then 120°C, 4 hours).

Assay Weigh accurately about 0.5 g of Calcium Lactate Hydrate, previously dried, add water, dissolve by heating on a water bath, cool, and add water to make exactly 100 mL. Pipet 20 mL of this solution, then 80 mL of water and 1.5 mL of 8 mol/L potassium hydroxide TS, and allow to stand for 3 to 5 minutes. Add 0.1 g of NN indicator, and titrate

<2.50> immediately with 0.02 mol/L disodium dihydrogen ethylenediamine tetraacetate VS until the color of the solution changes from red to blue.

Each mL of 0.02 mol/L disodium dihydrogen ethylenediamine tetraacetate VS
= 4.364 mg of $C_6H_{10}CaO_6$

Containers and storage Containers—Tight containers.

Calcium Levofolate Hydrate

レボホリナートカルシウム水和物

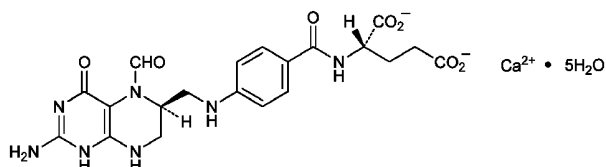

$C_{20}H_{21}CaN_7O_7 \cdot 5H_2O$: 601.58

Monocalcium *N*-[4-({[(6*S*)-2-amino-5-formyl-4-oxo-1,4,5,6,7,8-hexahydropteridin-6-yl]methyl}amino)benzoyl]-*L*-glutamate pentahydrate
[419573-16-3]

Calcium Levofolate Hydrate contains not less than 97.0% and not more than 102.0% of calcium levofolate ($C_{20}H_{21}CaN_7O_7$: 511.50), calculated on the anhydrous and residual solvent-free basis.

Description Calcium Levofolate Hydrate occurs as a white to light yellow crystalline powder.

It is sparingly soluble in water, and practically insoluble in methanol and in ethanol (99.5).

It is hygroscopic.

Optical rotation $[\alpha]_D^{25}$: $-10 - -15^\circ$ (0.25 g calculated on the anhydrous and residual solvent-free basis, 0.2 mol/L tris buffer solution (pH 8.1), 25 mL, 100 mm).

Identification (1) Determine the absorption spectrum of a solution of Calcium Levofolate Hydrate (1 in 100,000) as directed under Ultraviolet-visible Spectrophotometry <2.24>, and compare the spectrum with the Reference Spectrum: both spectra exhibit similar intensities of absorption at the same wavelengths.

(2) Determine the infrared absorption spectrum of Calcium Levofolate Hydrate as directed in the potassium bromide disk method under Infrared Spectrophotometry <2.25>, and compare the spectrum with the Reference Spectrum: both spectra exhibit similar intensities of absorption at the same wave numbers.

(3) A solution of Calcium Levofolate Hydrate (1 in 200) responds to Qualitative Tests <1.09> (2) and (3) for calcium salt.

pH <2.54> To 0.4 g of Calcium Levofolate Hydrate add 50 mL of freshly boiled and cooled water, and warm to 40°C, if necessary, to dissolve: the pH of the solution is between 7.0 and 8.5.

Purity (1) Clarity and color of solution—To 0.4 g of Calcium Levofolate Hydrate add 50 mL of water, and warm to 40°C, if necessary, to dissolve: the solution is clear, and its absorbance at 420 nm determined as directed under Ultraviolet-visible Spectrophotometry <2.24> is not more than 0.25.

(2) Chloride—To 0.300 g of Calcium Levofolate Hy-

drate add 50 mL of water, warm to 40°C, if necessary, to dissolve, add 10 mL of 2 mol/L nitric acid TS, and titrate <2.50> with 0.005 mol/L silver nitrate VS (potentiometric titration) (not more than 0.5%).

Each mL of 0.005 mol/L silver nitrate VS
= 0.177 mg of Cl

(3) Heavy metals <1.07>—Proceed with 1.0 g of Calcium Levofolate Hydrate according to Method 2, and perform the test. Prepare the control solution with 2.0 mL of Standard Lead Solution (not more than 20 ppm).

(4) Platinum—Being specified separately when the drug is granted approval based on the Law (not more than 5 ppm).

(5) Related substances—Dissolve 20 mg of Calcium Levofolate Hydrate in 25 mL of water, and use this solution as the sample solution. Pipet 1 mL of the sample solution, add water to make exactly 200 mL, and use this solution as the standard solution. Perform the test with exactly 20 μ L each of the sample solution and standard solution as directed under Liquid Chromatography <2.01> according to the following conditions. Determine each peak area by the automatic integration method: the area of the peak other than levofolate obtained from the sample solution is not larger than the peak area of levofolate from the standard solution, and the total area of the peaks other than levofolate from the sample solution is not larger than 5 times the peak area of levofolate from the standard solution.

Operating conditions—

Detector, column, column temperature, mobile phase, and flow rate: Proceed as directed in the operating conditions in the Assay.

Time span of measurement: About 3 times as long as the retention time of levofolate, beginning after the solvent peak.

System suitability—

Test for required detectability: To exactly 5 mL of the standard solution add water to make exactly 25 mL. Confirm that the peak area of levofolate obtained with 20 μ L of this solution is equivalent to 14 to 26% of that with 20 μ L of the standard solution.

System performance: When the procedure is run with 20 μ L of the standard solution under the above operating conditions, the number of theoretical plates and the symmetry factor of the peak of levofolate are not less than 1500 and not more than 1.5, respectively.

System repeatability: When the test is repeated 6 times with 20 μ L of the standard solution under the above operating conditions, the relative standard deviation of the peak area of levofolate is not more than 2.0%.

(6) Diastereomer—Dissolve 50 mg of Calcium Levofolate Hydrate in 100 mL of water, and use this solution as the sample solution. Perform the test with 10 μ L of the sample solution as directed under Liquid Chromatography <2.01> according to the following conditions. Determine each peak area by the automatic integration method, and calculate their amounts by the area percentage method: the amount of the peak of the diastereomer, having the relative retention time of about 2.0 to levofolate, is not more than 0.3%.

Operating conditions—

Detector: An ultraviolet absorption photometer (wavelength: 286 nm).

Column: A stainless steel column 4 mm in inside diameter and 15 cm in length, packed with human albumin chemically bonded silica gel for liquid chromatography (5 μ m in particle

diameter).

Column temperature: A constant temperature of about 40°C.

Mobile phase: Dissolve 3.4 g of sodium dihydrogen phosphate dihydrate in 870 mL of water, adjust to pH 4.9 with sodium hydroxide TS or phosphoric acid, and add 110 mL of 2-propanol and 20 mL of acetonitrile.

Flow rate: Adjust so that the retention time of levofolate is about 16 minutes.

System suitability—

Test for required detectability: Dissolve 10 mg of Calcium Folate RS in water to make 50 mL. To 1 mL of this solution add the sample solution to make 20 mL, and use this solution as the solution for system suitability test. Pipet 1 mL of the solution for system suitability test, and add water to make exactly 10 mL. Confirm that the peak area of the diastereomer obtained with 10 μ L of this solution is equivalent to 7 to 13% of that with 10 μ L of the solution for system suitability test.

System performance: When the procedure is run with 10 μ L of the solution for system suitability test under the above operating conditions, levofolate and the diastereomer are eluted in this order with the resolution between these peaks being not less than 5.

System repeatability: When the test is repeated 6 times with 10 μ L of the solution for system suitability test under the above operating conditions, the relative standard deviation of the peak area of the diastereomer is not more than 2.0%.

Water <2.48> 12.0 – 17.0% (0.2 g, volumetric titration, direct titration).

Assay Weigh accurately about 10 mg each of Calcium Levofolate Hydrate and Calcium Folate RS (separately determine the water <2.48> in the same manner as Calcium Folate Hydrate), and dissolve each in water to make exactly 25 mL, and use these solutions as the sample solution and the standard solution, respectively. Perform the test with exactly 20 μ L each of the sample solution and standard solution as directed under Liquid Chromatography <2.01> according to the following conditions, and determine the peak area, A_T , of levofolate with the sample solution, and the peak area, A_S , of folinate with the standard solution.

$$\begin{aligned} \text{Amount (mg) of calcium levofolate (C}_{20}\text{H}_{21}\text{CaN}_7\text{O}_7) \\ = M_S \times A_T/A_S \end{aligned}$$

M_S : Amount (mg) of Calcium Folate RS taken, calculated on the anhydrous basis

Operating conditions—

Detector: An ultraviolet absorption photometer (wavelength: 254 nm).

Column: A stainless steel column 4.6 mm in inside diameter and 15 cm in length, packed with octadecylsilanized silica gel for liquid chromatography (5 μ m in particle diameter).

Column temperature: A constant temperature of about 45°C.

Mobile phase: Adjust the pH of a mixture of diluted 0.05 mol/L disodium hydrogen phosphate TS (4 in 25), methanol and tetrabutylammonium hydroxide TS (385:110:4) to 7.5 with phosphoric acid.

Flow rate: Adjust so that the retention time of folinate is about 10 minutes.

System suitability—

System performance: Dissolve 10 mg of folic acid in 50 mL of the mobile phase. To 5 mL of this solution add 5 mL of the standard solution. When the procedure is run with 20

μ L of this solution under the above operating conditions, folinate and folic acid are eluted in this order with the resolution between these peaks being not less than 10.

System repeatability: When the test is repeated 6 times with 20 μ L of the standard solution under the above operating conditions, the relative standard deviation of the peak area of folinate is not more than 1.0%.

Containers and storage Containers—Tight containers.

Storage—Light-resistant.

Calcium Oxide

酸化カルシウム

CaO: 56.08

Calcium Oxide, when incinerated, contains not less than 98.0% of calcium oxide (CaO).

Description Calcium Oxide occurs as hard, white masses, containing a powder. It is odorless.

It is very slightly soluble in boiling water, and practically insoluble in ethanol (95).

One gram of Calcium Oxide dissolves almost completely in 2500 mL of water.

It slowly absorbs moisture and carbon dioxide from air.

Identification (1) Moisten Calcium Oxide with water: heat is generated and a white powder is obtained. Mix the powder with about 5 times its mass of water: the mixture is alkaline.

(2) Dissolve 1 g of Calcium Oxide in 20 mL of water by adding a few drops of acetic acid (31): the solution responds to Qualitative Tests <1.09> for calcium salt.

Purity (1) Acid-insoluble substances—Disintegrate 5.0 g of Calcium Oxide with a small amount of water, add 100 mL of water, add dropwise hydrochloric acid with stirring until the solution becomes acidic, and further add 1 mL of hydrochloric acid. Boil the solution for 5 minutes, cool, filter through a glass filter (G4), wash the residue with boiling water until no turbidity is produced when silver nitrate TS is added to the last washing, and dry at 105°C to constant mass: the mass of the residue is not more than 10.0 mg.

(2) Carbonate—Disintegrate 1.0 g of Calcium Oxide with a small amount of water, mix thoroughly with 50 mL of water, allow to stand for a while, remove most of the supernatant milky liquid by decantation, and add an excess of dilute hydrochloric acid to the residue: no vigorous effervescence is produced.

(3) Magnesium and alkali metals—Dissolve 1.0 g of Calcium Oxide in 75 mL of water by adding dropwise hydrochloric acid, and further add 1 mL of hydrochloric acid. Boil for 1 to 2 minutes, neutralize with ammonia TS, add dropwise an excess of hot ammonium oxalate TS, heat the mixture on a water bath for 2 hours, cool, add water to make 200 mL, mix thoroughly, and filter. Evaporate 50 mL of the filtrate with 0.5 mL of sulfuric acid to dryness, and heat the residue strongly at 600°C to constant mass: the mass of the residue is not more than 15 mg.

Loss on ignition <2.43> Not more than 10.0% (1 g, 900°C, constant mass).

Assay Weigh accurately about 0.7 g of Calcium Oxide, previously incinerated at 900°C to constant mass and cooled in a desiccator (silica gel), and dissolve in 50 mL of water and 8

mL of diluted hydrochloric acid (1 in 3) by heating. Cool, and add water to make exactly 250 mL. Pipet 10 mL of the solution, add 50 mL of water, 2 mL of 8 mol/L potassium hydroxide TS and 0.1 g of NN indicator, and titrate <2.50> with 0.02 mol/L disodium dihydrogen ethylenediamine tetraacetate VS, until the red-purple color of the solution changes to blue.

Each mL of 0.02 mol/L disodium dihydrogen ethylenediamine tetraacetate VS
= 1.122 mg of CaO

Containers and storage Containers—Tight containers.

Calcium Pantothenate

パントテン酸カルシウム

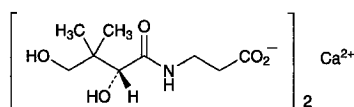

$C_{18}H_{32}CaN_2O_{10}$: 476.53

Monocalcium bis{3-[(2*R*)-2,4-dihydroxy-3,3-dimethylbutanoylamino]propanoate}

[137-08-6]

Calcium Pantothenate contains not less than 98.0% and not more than 102.0% of calcium pantothenate ($C_{18}H_{32}CaN_2O_{10}$), calculated on the dried basis.

Description Calcium Pantothenate occurs as a white powder.

It is freely soluble in water, and practically insoluble in ethanol (99.5).

The pH of a solution prepared by dissolving 1.0 g of Calcium Pantothenate in 20 mL of water is between 7.0 and 9.0.

It is hygroscopic.

It shows crystal polymorphism.

Identification (1) Determine the infrared absorption spectrum of previously dried Calcium Pantothenate as directed in the potassium bromide disk method under Infrared Spectrophotometry <2.25>, and compare the spectrum with the Reference Spectrum or the spectrum of dried Calcium Pantothenate RS: both spectra exhibit similar intensities of absorption at the same wave numbers. If any difference appears between the spectra, dissolve the sample and the Reference Standard separately in water, evaporate water, dry the residues in vacuum for 24 hours using silica gel as a desiccant, and perform the test using these residues.

(2) A solution of Calcium Pantothenate (1 in 10) responds to Qualitative Tests <1.09> (1), (2) and (3) for calcium salt.

Optical rotation <2.49> $[\alpha]_D^{20}$: +25.0 – +28.5° (1 g calculated on the dried basis, water, 20 mL, 100 mm).

Purity (1) Heavy metals <1.07>—Proceed with 1.0 g of Calcium Pantothenate according to Method 1, and perform the test. Prepare the control solution with 2.0 mL of Standard Lead Solution (not more than 20 ppm).

(2) Related substances—Dissolve 0.30 g of Calcium Pantothenate in 20 mL of water, and use this solution as the sample solution. Pipet 1 mL of the sample solution, add water to make exactly 200 mL, and use this solution as the standard solution. Perform the test with exactly 10 μ L each of the sample solution and standard solution as directed under Liquid Chromatography <2.01> according to the fol-

lowing conditions, and determine each peak area by the automatic integration method: the area of the peak, having the relative retention time of about 0.6 to pantothenic acid obtained from the sample solution is not larger than 1.2 times the peak area of pantothenic acid from the standard solution, the area of the peak, having the relative retention time of about 0.8 is not larger than the peak area of pantothenic acid from the standard solution, the area of the peak, having the relative retention time of about 1.5 is not larger than 3/5 times the peak area of pantothenic acid from the standard solution, and the area of the peak other than pantothenic acid and the peaks mentioned above is not larger than 3/10 times the peak area of pantothenic acid from the standard solution. Additionally, the total area of the peaks other than pantothenic acid from the sample solution is not larger than 2.4 times the peak area of pantothenic acid from the standard solution. For the areas of the peaks, having the relative retention time of about 0.6 and about 0.8 to pantothenic acid, multiply their correction factors, 19 and 13, respectively.

Operating conditions—

Detector, column, column temperature, mobile phase, and flow rate: Proceed as directed in the operating conditions in the Assay.

Time span of measurement: About 2 times as long as the retention time of pantothenic acid, beginning after the solvent peak.

System suitability—

Test for required detectability: To exactly 2 mL of the standard solution add water to make exactly 10 mL. Confirm that the peak area of pantothenic acid obtained with 10 μ L of this solution is equivalent to 14 to 26% of that with 10 μ L of the standard solution.

System performance: When the procedure is run with 10 μ L of the standard solution under the above operating conditions, the number of theoretical plates and the symmetry factor of the peak of pantothenic acid are not less than 10,000 and not more than 1.5, respectively.

System repeatability: When the test is repeated 6 times with 10 μ L of the standard solution under the above operating conditions, the relative standard deviation of the peak area of pantothenic acid is not more than 2.0%.

(3) Alkaloids—Dissolve 50 mg of Calcium Pantothenate in 5 mL of water, add 0.5 mL of hexaammonium heptamolybdate TS and 0.5 mL of a solution of phosphoric acid (1 in 10): no white turbidity is produced.

Loss on drying <2.41> Not more than 5.0% (1 g, 105°C, 4 hours).

Assay Weigh accurately about 20 mg each of Calcium Pantothenate and Calcium Pantothenate RS (separately determine the loss on drying <2.41> in the same conditions as Calcium Pantothenate), dissolve each in water to make exactly 100 mL, and use these solutions as the sample solution and the standard solution, respectively. Perform the test with exactly 10 μ L each of the sample solution and standard solution as directed under Liquid Chromatography <2.01> according to the following conditions, and determine the peak areas, A_T and A_S , of pantothenic acid in each solution.

Amount (mg) of calcium pantothenate ($C_{18}H_{32}CaN_2O_{10}$)
= $M_S \times A_T/A_S$

M_S : Amount (mg) of Calcium Pantothenate RS taken, calculated on the dried basis

Operating conditions—

Detector: An ultraviolet absorption photometer (wave-

length: 210 nm).

Column: A stainless steel column 4.6 mm in inside diameter and 25 cm in length, packed with octadecylsilanized silica gel for liquid chromatography (5 μ m in particle diameter).

Column temperature: A constant temperature of about 40°C.

Mobile phase: Dissolve 0.81 g of sodium 1-heptanesulfonate and 1.36 g of potassium dihydrogen phosphate in water to make 1000 mL, and adjust to pH 2.1 with phosphoric acid. To 980 mL of this solution add 10 mL of acetonitrile and 10 mL of methanol.

Flow rate: Adjust so that the retention time of pantothenic acid is about 17 minutes.

System suitability—

System performance: When the procedure is run with 10 μ L of the standard solution under the above operating conditions, the number of theoretical plates and the symmetry factor of the peak of pantothenic acid are not less than 10,000 and not more than 1.5, respectively.

System repeatability: When the test is repeated 6 times with 10 μ L of the standard solution under the above operating conditions, the relative standard deviation of the peak area of pantothenic acid is not more than 1.0%.

Containers and storage Containers—Tight containers.

Calcium Paraaminosalicylate Hydrate

Pas-calcium Hydrate

パラアミノサリチル酸カルシウム水和物

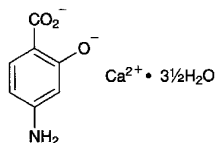

$C_7H_5CaNO_3 \cdot 3\frac{1}{2}H_2O$: 254.25

Monocalcium 4-amino-2-oxidobenzoate hemiheptahydrate
[137422-1-08-5, anhydride]

Calcium Paraaminosalicylate Hydrate contains not less than 97.0% and not more than 103.0% of calcium paraaminosalicylic acid ($C_7H_5CaNO_3$: 191.20), calculated on the anhydrous basis.

Description Calcium Paraaminosalicylate Hydrate occurs as a white to slightly colored powder. It has a slightly bitter taste.

It is very slightly soluble in water, and practically insoluble in methanol and in ethanol (99.5).

It is gradually colored to brown by light.

Identification (1) To 50 mg of Calcium Paraaminosalicylate Hydrate add 100 mL of water, shake well, and filter. To 10 mL of the filtrate add 1 mL of 1 mol/L hydrochloric acid TS, shake, and add 1 drop of iron (III) chloride TS: a red-purple color develops.

(2) Determine the infrared absorption spectrum of Calcium Paraaminosalicylate Hydrate as directed in the potassium bromide disk method under Infrared Spectrophotometry <2.25>, and compare the spectrum with the Reference Spectrum: both spectra exhibit similar intensities of absorption at the same wave numbers.

(3) To 3 g of Calcium Paraaminosalicylate Hydrate add

15 mL of ammonium chloride TS and 15 mL of water, heat on a water bath until almost dissolved, and filter after cooling: the filtrate responds to Qualitative Tests <1.09> (1), (2) and (3) for calcium salt.

Purity (1) Chloride <1.03>—Dissolve 1.0 g of Calcium Paraaminosalicylate Hydrate in 15 mL of dilute nitric acid, and add water to make 50 mL. Perform the test using this solution as the test solution. Prepare the control solution with 0.70 mL of 0.01 mol/L hydrochloric acid VS (not more than 0.025%).

(2) Heavy metals <1.07>—Proceed with 1.0 g of Calcium Paraaminosalicylate Hydrate according to method 3, and perform the test. Prepare the control solution with 2.0 mL of Standard Lead Solution (not more than 20 ppm).

(3) Arsenic <1.11>—Dissolve 0.40 g of Calcium Paraaminosalicylate Hydrate in 20 mL of 0.1 mol/L hydrochloric acid TS by warming on a water bath, use this solution as the test solution, and perform the test (not more than 5 ppm).

(4) 3-Aminophenol—To 0.10 g of Calcium Paraaminosalicylate Hydrate add 5 mL of 0.1 mol/L disodium dihydrogen ethylenediamine tetraacetate TS, previously cooled in ice-water, and dissolve by shaking vigorously. Add immediately 3 mL of ammonia-ammonium chloride buffer solution (pH 11.0) previously cooled in ice water, and shake. Add 2 mL of 4-amino-*N,N*-diethylaniline sulfate TS, shake, add 10.0 mL of cyclohexane and 4 mL of diluted potassium hexacyanoferrate (III) TS (1 in 10), and shake immediately for 20 seconds. Centrifuge this solution, wash the separated cyclohexane layer with two 5-mL portions of diluted ammonia TS (1 in 14), add 1 g of anhydrous sodium sulfate, shake, and allow to stand for 5 minutes: the clear cyclohexane layer is not more colored than the following control solution.

Control solution: Dissolve 50 mg of 3-aminophenol in water, and dilute with water to exactly 500 mL. Measure exactly 20 mL of this solution, and add water to make exactly 100 mL. Take 5.0 mL of this solution, add 3 mL of ammonia-ammonium chloride buffer solution (pH 11.0) previously cooled in ice-water, and treat this solution in the same manner as the sample.

Water <2.48> 23.3 – 26.3% (0.1 g, volumetric titration, direct titration).

Assay Weigh accurately about 0.2 g of Calcium Paraaminosalicylate Hydrate, dissolve in 60 mL of water and 0.75 mL of dilute hydrochloric acid by warming on a water bath. After cooling, add water to make exactly 100 mL, and use this solution as the sample solution. Measure exactly 30 mL of the sample solution, transfer to an iodine flask, and add exactly 25 mL of 0.05 mol/L bromine VS and 20 mL of a solution of potassium bromide (1 in 4). Add immediately 14 mL of a mixture of acetic acid (100) and hydrochloric acid (5:2), stopper the flask immediately, and allow to stand for 10 minutes with occasional shaking. Add cautiously 6 mL of potassium iodide TS, and shake gently. After 5 minutes, titrate <2.50> the produced iodine with 0.1 mol/L sodium thiosulfate VS (indicator: 1 mL of starch TS). Perform a blank determination in the same manner.

Each mL of 0.05 mol/L bromine VS
= 3.187 mg of $C_7H_5CaNO_3$

Containers and storage Containers—Tight containers.
Storage—Light-resistant.

Calcium Paraaminosalicylate Granules

Pas-calcium Granules

パラアミノサリチル酸カルシウム顆粒

Calcium Paraaminosalicylate Granules contain not less than 95.0% and not more than 105.0% of the labeled amount of calcium paraaminosalicylate hydrate ($C_7H_5CaNO_3 \cdot 3\frac{1}{2}H_2O$; 254.25).

Method of preparation Prepare as directed under Granules, with Calcium Paraaminosalicylate Hydrate.

Identification Powder Calcium Paraaminosalicylate Granules, weigh a portion of the powder, equivalent to 50 mg of Calcium Paraaminosalicylate Hydrate, add 100 mL of water, shake, and filter. To 10 mL of the filtrate add 1 mL of 1 mol/L hydrochloric acid TS, shake, and add 1 drop of iron (III) chloride TS: a red-purple color develops.

Dissolution <6.10> When the test is performed at 75 revolutions per minute according to the Paddle method, using 900 mL of water as the dissolution medium, the dissolution rate in 60 minutes of Calcium Paraaminosalicylate Granules is not less than 75%.

Start the test with an accurately weighed amount of Calcium Paraaminosalicylate Granules, equivalent to about 0.25 g of calcium paraaminosalicylate hydrate ($C_7H_5CaNO_3 \cdot 3\frac{1}{2}H_2O$), withdraw not less than 20 mL of the medium at the specified minute after starting the test, and filter through a membrane filter with a pore size not exceeding 0.5 μm . Discard not less than 10 mL of the first filtrate, pipet 5 mL of the subsequent filtrate, add water to make exactly 100 mL, and use this solution as the sample solution. Separately, weigh accurately about 28 mg of calcium paraaminosalicylate hydrate for assay (separately determine the water <2.48> in the same manner as Calcium Paraaminosalicylate Hydrate), and dissolve in water to make exactly 100 mL. Pipet 5 mL of this solution, add water to make exactly 100 mL, and use this solution as the standard solution. Determine the absorbances, A_T and A_S , at 300 nm of the sample solution and standard solution as directed under Ultraviolet-visible Spectrophotometry <2.24>.

Dissolution rate (%) with respect to the labeled amount of calcium paraaminosalicylate hydrate

$$= M_S/M_T \times A_T/A_S \times 1/C \times 900 \times 1.330$$

M_S : Amount (mg) of calcium paraaminosalicylate hydrate for assay taken, calculated on the anhydrous basis

M_T : Amount (g) of Calcium Paraaminosalicylate Granules taken

C : Labeled amount (mg) of calcium paraaminosalicylate hydrate ($C_7H_5CaNO_3 \cdot 3\frac{1}{2}H_2O$) in 1 g

Assay Powder Calcium Paraaminosalicylate Granules, weigh accurately a portion of the powder, equivalent to about 0.2 g of calcium paraaminosalicylate hydrate ($C_7H_5CaNO_3 \cdot 3\frac{1}{2}H_2O$), add 60 mL of water and 0.75 mL of dilute hydrochloric acid, and dissolve by heating on a water bath. After cooling, add water to make exactly 100 mL, and filter. Pipet 30 mL of the filtrate, transfer to an iodine flask, and proceed as directed in the Assay under Calcium Paraaminosalicylate Hydrate.

Each mL of 0.05 mol/L bromine VS
= 4.238 mg of $C_7H_5CaNO_3 \cdot 3\frac{1}{2}H_2O$

Containers and storage Containers—Tight containers.

Storage—Light-resistant.

Anhydrous Dibasic Calcium Phosphate

無水リン酸水素カルシウム

$CaHPO_4$; 136.06

[7757-93-9]

This monograph is harmonized with the European Pharmacopoeia and the U.S. Pharmacopoeia.

The corresponding part of the attributes/provisions which are agreed as non-harmonized within the scope of the harmonization is marked with symbols (◆ ◆), and the corresponding parts which are agreed as the JP local requirement other than the scope of the harmonization are marked with symbols (◇ ◇).

Information on the harmonization with the European Pharmacopoeia and the U.S. Pharmacopoeia is available on the website of the Pharmaceuticals and Medical Devices Agency.

Anhydrous Dibasic Calcium Phosphate contains not less than 97.5% and not more than 102.5% of dibasic calcium phosphate ($CaHPO_4$).

◆**Description** Anhydrous Dibasic Calcium Phosphate occurs as white, crystalline powder or granules.

It is practically insoluble in water and in ethanol (99.5).

It dissolves in dilute hydrochloric acid and in dilute nitric acid.◆

Identification (1) Dissolve 0.1 g of Anhydrous Dibasic Calcium Phosphate in 10 mL of 2 mol/L hydrochloric acid TS by warming, add 2.5 mL of ammonia TS dropwise with shaking, and add 5 mL of ammonium oxalate TS: a white precipitate is produced.

(2) Dissolve 0.1 g of Anhydrous Dibasic Calcium Phosphate in 5 mL of dilute nitric acid, and add 2 mL of hexaammonium heptamolybdate TS after warming at 70°C for 1 to 2 minutes: a yellow precipitate is produced.

Purity (1) Acid-insoluble substances—Dissolve 5.0 g of Anhydrous Dibasic Calcium Phosphate in 40 mL of water and 10 mL of hydrochloric acid, and boil gently for 5 minutes. After cooling, collect the insoluble substance using a filter paper for quantitative analysis. Wash with water until no more turbidity of the washings is produced when silver nitrate TS is added. Ignite to incinerate the residue and the filter paper at $600 \pm 50^\circ C$: the mass is not more than 10 mg (not more than 0.2%).

(2) Chloride—To 0.20 g of Anhydrous Dibasic Calcium Phosphate add 20 mL of water and 13 mL of dilute nitric acid, dissolve by warming, if necessary, add water to make 100 mL, and filter, if necessary. Put 50 mL of this solution in a Nessler tube, and use this as the sample solution. Separately, transfer 0.70 mL of 0.01 mol/L hydrochloric acid VS to another Nessler tube, add 6 mL of dilute nitric acid and water to make 50 mL, and use this solution as the control solution. Add 1 mL of silver nitrate TS to the sample solution and control solution, mix well, and allow to stand for 5 minutes protecting from light. Compare the opalescence de-

veloped in both solutions against a black background by viewing downward or transversely. The opalescence developed in the sample solution is not more than that of the control solution (not more than 0.25%).

(3) Sulfate—Dissolve 0.50 g of Anhydrous Dibasic Calcium Phosphate in 5 mL of water and 5 mL of dilute hydrochloric acid, add water to make 100 mL, and filter, if necessary. Put 20 mL of this solution in a Nessler tube, add 1 mL of dilute hydrochloric acid, and add water to make 50 mL, and use this as the sample solution. Transfer 1.0 mL of 0.005 mol/L sulfuric acid VS to another Nessler tube, add 1 mL of dilute hydrochloric acid and water to make 50 mL, and use this solution as the control solution. Add 2 mL of barium chloride TS to the sample solution and control solution, mix well, and allow to stand for 10 minutes. Compare the white turbidity produced in both solutions against a black background by viewing downward or transversely. The turbidity produced in the sample solution is not thicker than that of the control solution (not more than 0.48%).

(4) Carbonate—Shake 1.0 g of Anhydrous Dibasic Calcium Phosphate with 5 mL of freshly boiled and cooled water, and add immediately 2 mL of hydrochloric acid: no effervescence occurs.

◇(5) Heavy metals <1.07>—Dissolve 0.65 g of Anhydrous Dibasic Calcium Phosphate in a mixture of 5 mL of water and 5 mL of dilute hydrochloric acid by warming, cool, and add ammonia TS until precipitates begin to form in the solution. Dissolve the precipitates by adding a small amount of dilute hydrochloric acid dropwise, add 10 mL of hydrochloric acid-ammonium acetate buffer solution (pH 3.5) and water to make 50 mL, and perform the test using this solution as the sample solution. Prepare the control solution as follows: to 10 mL of hydrochloric acid-ammonium acetate buffer solution (pH 3.5) add 2.0 mL of Standard Lead Solution and water to make 50 mL (not more than 31 ppm).◇

(6) Barium—Heat 0.5 g of Anhydrous Dibasic Calcium Phosphate with 10 mL of water, add 1 mL of hydrochloric acid dropwise with stirring, and filter after cooling, if necessary. Add 2 mL of potassium sulfate TS to this solution, and allow to stand for 10 minutes: no turbidity forms.

◆(7) Arsenic <1.11>—Dissolve 1.0 g of Anhydrous Dibasic Calcium Phosphate in 5 mL of dilute hydrochloric acid, and perform the test with this solution as the test solution (not more than 2 ppm).◆

Loss on ignition <2.43> Not less than 6.6% and not more than 8.7% (1 g, 800 – 825°C, constant mass).

Assay Weigh accurately about 0.4 g of Anhydrous Dibasic Calcium Phosphate, dissolve in 12 mL of dilute hydrochloric acid by heating on a water bath, if necessary, and add water to make exactly 200 mL. Pipet 20 mL of this solution, add exactly 25 mL of 0.02 mol/L disodium dihydrogen ethylenediamine tetraacetate VS, 50 mL of water and 5 mL of ammonia-ammonium chloride buffer solution (pH 10.7), and titrate <2.50> the excess disodium dihydrogen ethylenediamine tetraacetate with 0.02 mol/L zinc sulfate VS (indicator: 25 mg of eriochrome black T-sodium chloride indicator). Perform a blank determination in the same manner.

Each mL of 0.02 mol/L disodium dihydrogen ethylenediamine tetraacetate VS
= 2.721 mg of CaHPO₄

◆**Containers and storage** Containers—Well-closed containers.◆

Dibasic Calcium Phosphate Hydrate

リン酸水素カルシウム水和物

CaHPO₄·2H₂O: 172.09
[7789-77-7]

This monograph is harmonized with the European Pharmacopoeia and the U.S. Pharmacopoeia.

The parts of the text that are not harmonized are marked with symbols (◆ ◆).

Information on the harmonization with the European Pharmacopoeia and the U.S. Pharmacopoeia is available on the website of the Pharmaceuticals and Medical Devices Agency.

Dibasic Calcium Phosphate Hydrate contains not less than 98.0% and not more than 105.0% of dibasic calcium phosphate hydrate (CaHPO₄·2H₂O).

◆**Description** Dibasic Calcium Phosphate Hydrate occurs as a white crystalline powder.

It is practically insoluble in water and in ethanol (99.5).

It dissolves in dilute hydrochloric acid and in dilute nitric acid.◆

Identification (1) Dissolve 0.1 g of Dibasic Calcium Phosphate Hydrate in 10 mL of 2 mol/L hydrochloric acid TS by warming, add 2.5 mL of ammonia TS dropwise with shaking, and add 5 mL of ammonium oxalate TS: a white precipitate is produced.

(2) Dissolve 0.1 g of Dibasic Calcium Phosphate Hydrate in 5 mL of dilute nitric acid, and add 2 mL of hexaammonium heptamolybdate TS after warming at 70°C for 1 to 2 minutes: a yellow precipitate is produced.

Purity (1) Acid-insoluble substance—Dissolve 5.0 g of Dibasic Calcium Phosphate Hydrate in 40 mL of water and 10 mL of hydrochloric acid, and boil gently for 5 minutes. After cooling, collect the insoluble substance using a filter paper for quantitative analysis. Wash with water until no more turbidity of the washing is produced when silver nitrate TS is added. Ignite to incinerate the residue and filter paper at 600 ± 50°C: the mass is not more than 10 mg (not more than 0.2%).

(2) Chloride—To 0.20 g of Dibasic Calcium Phosphate Hydrate add 20 mL of water and 13 mL of dilute nitric acid, dissolve by warming, if necessary, add water to make 100 mL, and filter, if necessary. Put 50 mL of this solution in a Nessler tube, and use this as the test solution. Transfer 0.70 mL of 0.01 mol/L hydrochloric acid VS to another Nessler tube, add 6 mL of dilute nitric acid and water to make 50 mL, and use this solution as the control solution. Add 1 mL of silver nitrate TS to the test solution and the control solution, mix well, and allow to stand for 5 minutes protecting from light. Compare the opalescence developed in both solutions against a black background by viewing downward or transversely. The opalescence developed in the test solution is not more than that of the control solution. (not more than 0.25%)

(3) Sulfate—Dissolve 0.50 g of Dibasic Calcium Phosphate Hydrate in 5 mL of water and 5 mL of dilute hydrochloric acid, add water to make 100 mL, and filter, if necessary. Put 20 mL of this solution in a Nessler tube, add 1 mL of dilute hydrochloric acid, and add water to make 50 mL, and use this as the test solution. Transfer 1.0 mL of 0.005 mol/L sulfuric acid VS to another Nessler tube, add 1 mL of

dilute hydrochloric acid and water to make 50 mL, and use this solution as the control solution. Add 2 mL of barium chloride TS to the test solution and the control solution, mix well, and allow to stand for 10 minutes. Compare the white turbidity produced in both solutions against a black background by viewing downward or transversely. The turbidity produced in the test solution is not thicker than that of the control solution. (not more than 0.48%)

(4) Carbonate—Mix 1.0 g of Dibasic Calcium Phosphate Hydrate with 5 mL of freshly boiled and cooled water, and add immediately 2 mL of hydrochloric acid: no effervescence occurs.

◆(5) Heavy metals <1.07>—Dissolve 0.65 g of Dibasic Calcium Phosphate Hydrate in a mixture of 5 mL of water and 5 mL of dilute hydrochloric acid by warming, cool, and add ammonia TS until precipitates begin to form in the solution. Dissolve the precipitates by adding a small amount of dilute hydrochloric acid dropwise, add 10 mL of hydrochloric acid-ammonium acetate buffer solution (pH 3.5) and water to make 50 mL, and perform the test using this solution as the test solution. Prepare the control solution as follows: to 10 mL of hydrochloric acid-ammonium acetate buffer solution (pH 3.5) add 2.0 mL of Standard Lead Solution and water to make 50 mL (not more than 31 ppm).◆

(6) Barium—Heat 0.5 g of Dibasic Calcium Phosphate Hydrate with 10 mL of water, add 1 mL of hydrochloric acid dropwise with stirring, and filter after cooling, if necessary. Add 2 mL of potassium sulfate TS to this solution, and allow to stand for 10 minutes: no turbidity forms.

◆(7) Arsenic <1.11>—Dissolve 1.0 g of Dibasic Calcium Phosphate Hydrate in 5 mL of dilute hydrochloric acid, and perform the test with this solution as the test solution (not more than 2 ppm).◆

Loss on ignition <2.43> Not less than 24.5% and not more than 26.5% (1 g, 800 – 825°C, constant mass).

Assay Weigh accurately about 0.4 g of Dibasic Calcium Phosphate Hydrate, dissolve in 12 mL of dilute hydrochloric acid by warming on a water bath, if necessary, and add water to make exactly 200 mL. Pipet 20 mL of this solution, add exactly 25 mL of 0.02 mol/L disodium dihydrogen ethylenediamine tetraacetate VS, 50 mL of water and 5 mL of ammonia-ammonium chloride buffer solution (pH 10.7), and titrate <2.50> the excess disodium dihydrogen ethylenediamine tetraacetate with 0.02 mol/L zinc sulfate VS (indicator: 25 mg of eriochrome black T-sodium chloride indicator). Perform a blank determination in the same manner.

Each mL of 0.02 mol/L disodium dihydrogen ethylenediamine tetraacetate VS
= 3.442 mg of CaHPO₄·2H₂O

◆**Containers and storage** Containers—Well-closed containers.◆

Monobasic Calcium Phosphate Hydrate

リン酸二水素カルシウム水和物

Ca(H₂PO₄)₂·H₂O: 252.07

Monobasic Calcium Phosphate Hydrate, when dried, contains not less than 90.0% of monobasic calcium phosphate hydrate [Ca(H₂PO₄)₂·H₂O].

Description Monobasic Calcium Phosphate Hydrate occurs as white, crystals or crystalline powder. It is odorless and has an acid taste.

It is sparingly soluble in water, and practically insoluble in ethanol (95) and in diethyl ether.

It dissolves in dilute hydrochloric acid and in dilute nitric acid.

It is slightly deliquescent.

Identification (1) Dissolve 0.1 g of Monobasic Calcium Phosphate Hydrate in 10 mL of diluted hydrochloric acid (1 in 6) by warming, add 2.5 mL of ammonia TS dropwise with shaking, and add 5 mL of ammonium oxalate TS: a white precipitate is produced.

(2) Dissolve 0.1 g of Monobasic Calcium Phosphate Hydrate in 5 mL of dilute nitric acid, and add 2 mL of hexaammonium heptamolybdate TS after warming for 1 to 2 minutes at 70°C: a yellow precipitate is produced.

Purity (1) Clarity and color of solution—Dissolve 1.0 g of Monobasic Calcium Phosphate Hydrate in 19 mL of water and 2 mL of diluted hydrochloric acid (3 in 4), and heat on a water bath for 5 minutes with occasional shaking: the solution is clear and colorless.

(2) Dibasic phosphate and acid—Triturate 1.0 g of Monobasic Calcium Phosphate Hydrate with 3 mL of water, and add 100 mL of water and 1 drop of methyl orange TS: a red color develops. Then add 1.0 mL of 1 mol/L sodium hydroxide VS: the color changes to yellow.

(3) Chloride <1.03>—Dissolve 1.0 g of Monobasic Calcium Phosphate Hydrate in 20 mL of water and 12 mL of dilute nitric acid, add water to make 100 mL, and filter, if necessary. Perform the test using 50 mL of this solution as the test solution. Prepare the control solution with 0.25 mL of 0.01 mol/L hydrochloric acid VS (not more than 0.018%).

(4) Sulfate <1.14>—Dissolve 1.0 g of Monobasic Calcium Phosphate Hydrate in 20 mL of water and 1 mL of hydrochloric acid, add water to make 100 mL, and filter, if necessary. Perform the test using 50 mL of this solution as the test solution. Prepare the control solution with 0.50 mL of 0.005 mol/L sulfuric acid VS (not more than 0.048%).

(5) Heavy metals <1.07>—Dissolve 0.65 g of Monobasic Calcium Phosphate Hydrate in a mixture of 5 mL of water and 5 mL of dilute hydrochloric acid by warming, cool, and add ammonia TS until precipitates begin to form in the solution. Dissolve the precipitates by adding a small amount of dilute hydrochloric acid dropwise, add 10 mL of hydrochloric acid-ammonium acetate buffer solution (pH 3.5) and water to make 50 mL, and perform the test using this solution as the test solution. Prepare the control solution as follows: to 10 mL of hydrochloric acid-ammonium acetate buffer solution (pH 3.5) add 2.0 mL of Standard Lead Solution and water to make 50 mL (not more than 31 ppm).

(6) Arsenic <1.11>—Dissolve 1.0 g of Monobasic Calcium Phosphate Hydrate in 5 mL of dilute hydrochloric acid, and perform the test with this solution as the test solution (not more than 2 ppm).

Loss on drying <2.41> Not more than 3.0% (1 g, silica gel, 24 hours).

Assay Weigh accurately about 0.4 g of Monobasic Calcium Phosphate Hydrate, previously dried, dissolve in 3 mL of dilute hydrochloric acid, and add water to make exactly 100 mL. Pipet 20 mL of this solution, add exactly 25 mL of 0.02 mol/L disodium dihydrogen ethylenediamine tetraacetate VS, 50 mL of water and 5 mL of ammonia-ammonium chloride buffer solution (pH 10.7), and titrate <2.50> the excess

disodium dihydrogen ethylenediamine tetraacetate with 0.02 mol/L zinc acetate VS (indicator: 25 mg of eriochrome black T-sodium chloride indicator). Perform a blank determination in the same manner.

Each mL of 0.02 mol/L disodium dihydrogen ethylenediamine tetraacetate VS
= 5.041 mg of $\text{Ca}(\text{H}_2\text{PO}_4)_2 \cdot \text{H}_2\text{O}$

Containers and storage Containers—Tight containers.

Calcium Polystyrene Sulfonate

ポリスチレンスルホン酸カルシウム

Calcium Polystyrene Sulfonate is a cation exchange resin prepared as the calcium form of the sulfonated styrene divinylbenzene copolymer.

When dried, it contains not less than 7.0% and not more than 9.0% of calcium (Ca: 40.08).

Each g of Calcium Polystyrene Sulfonate, when dried, exchanges with 53 to 71 mg of potassium (K: 39.10).

Description Calcium Polystyrene Sulfonate occurs as a pale yellow-white to light yellow powder. It is odorless and tasteless.

It is practically insoluble in water, in ethanol (95) and in diethyl ether.

Identification (1) Determine the infrared absorption spectrum of Calcium Polystyrene Sulfonate, previously dried, as directed in the potassium bromide disk method under Infrared Spectrophotometry <2.25>, and compare the spectrum with the Reference Spectrum: both spectra exhibit similar intensities of absorption at the same wave numbers.

(2) Mix 0.5 g of Calcium Polystyrene Sulfonate with 10 mL of dilute hydrochloric acid, filter, and neutralize the filtrate with ammonia TS: the solution responds to Qualitative Tests <1.09> for calcium salt.

Purity (1) Ammonium—Place 1.0 g of Calcium Polystyrene Sulfonate in a flask, add 5 mL of sodium hydroxide TS, cover the flask with a watch glass having a moistened strip of red litmus paper on the underside, and boil for 15 minutes: the gas evolved does not change the red litmus paper to blue (not more than 5 ppm).

(2) Heavy metals <1.07>—Proceed with 2.0 g of Calcium Polystyrene Sulfonate according to Method 2, and perform the test. Prepare the control solution with 2.0 mL of Standard Lead Solution (not more than 10 ppm).

(3) Arsenic <1.11>—Prepare the test solution with 1.0 g of Calcium Polystyrene Sulfonate according to Method 3, and perform the test (not more than 2 ppm).

(4) Styrene—To 10.0 g of Calcium Polystyrene Sulfonate add 10 mL of acetone, shake for 30 minutes, centrifuge, and use the supernatant liquid as the sample solution. Separately, dissolve 10 mg of styrene in acetone to make exactly 100 mL. Pipet 1 mL of this solution, dilute with acetone to make exactly 100 mL, and use this solution as the standard solution. Perform the test with exactly 5 μL each of the sample solution and standard solution as directed under Gas Chromatography <2.02> according to the following conditions. Determine the peak heights, H_T and H_S , of styrene in each solution: H_T is not larger than H_S .

Operating conditions—

Detector: A hydrogen flame-ionization detector.

Column: A stainless steel column 3 mm in inside diameter

and 2 m in length, having polyethylene glycol 20 M coated at the ratio of 15% on siliceous earth for gas chromatography (150 to 180 μm in particle diameter).

Column temperature: A constant temperature of about 90°C.

Carrier gas: Nitrogen.

Flow rate: Adjust so that the retention time of styrene is about 9 minutes.

System suitability—

System performance: Mix 10 mg of styrene with 1000 mL of acetone. When the procedure is run with 5 μL of this solution under the above operating conditions, the number of theoretical plates and the symmetry factor of the peak of styrene are not less than 800 and 0.8 to 1.2, respectively.

System repeatability: When the test is repeated 6 times with 5 μL of the standard solution under the above operating conditions, the relative standard deviation of the peak heights of styrene is not more than 5%.

(5) Sodium—Pipet 2 mL of the 50-mL solution obtained in the Assay (1), add 0.02 mol/L hydrochloric acid TS to make exactly 500 mL, and use this solution as the sample solution. Separately, weigh accurately 0.2542 g of sodium chloride, previously dried at 130°C for 2 hours, and dissolve in 0.02 mol/L hydrochloric acid TS to make exactly 1000 mL. Pipet a suitable volume of this solution, and dilute with 0.02 mol/L hydrochloric acid TS to make a solution containing 1 to 3 μg of sodium (Na: 22.99) per mL, and use these solutions as the standard solutions. Perform the test with the sample solution and standard solutions according to Atomic Absorption Spectrophotometry <2.23> under the following conditions, and determine the amount of sodium in the sample solution using the calibration curve obtained from the standard solutions: the amount of sodium is not more than 1%.

Gas: Combustible gas—Acetylene.

Supporting gas—Air.

Lamp: A sodium hollow-cathode lamp.

Wavelength: 589.0 nm.

Loss on drying <2.41> Not more than 10.0% (1 g, in vacuum, 80°C, 5 hours).

Microparticles (i) Apparatus: Use an apparatus as shown in the illustration.

(ii) Procedure: Weigh accurately about 5.5 g of Calcium Polystyrene Sulfonate, previously dried, add 300 mL of water of 25°C, and mix for 5 minutes. Transfer this turbid solution to the sedimentation tube J, keeping a temperature at 25°C, add water of 25°C to 2 mm below the mark F of 20 cm of the sedimentation tube J, and then insert the pipet. Open the two-way stopcock C, exhaust air, add exactly water from the vent-hole D to the mark F of 20 cm, and close the two-way stopcock C. Shake the apparatus well vertically and horizontally, disperse Calcium Polystyrene Sulfonate in water, and then open the two-way stopcock, and allow to stand at $25 \pm 1^\circ\text{C}$ for 5 hours and 15 minutes.

Then, draw exactly the meniscus of the turbid solution in sedimentation tube J up to the mark of pipet bulb A by suction, open the two-way stopcock C to the outlet of pipet H, and transfer exactly measured 20 mL of the turbid solution to a weighing bottle. Repeat the procedure, and combine exactly measured 20 mL of the turbid solution. Evaporate 20 mL of this turbid solution on a water bath to dryness, dry to constant mass at 105°C, and weigh the residue as M_S (g). Pipet 20 mL of used water, and weigh the residue in the same manner as M_B (g). Calculate the difference mi (g) between M_S and M_B , and calculate the amount of microparticles (S) by the following equation: the amount of microparticles is

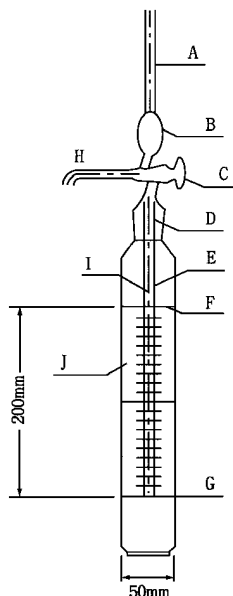

Actual volume to the mark of 20 cm at which the sedimentation tube is inserted: 550 mL

Single suction volume: 10 mL

- A: Mark of pipet bulb
- B: Pipet bulb for suction
- C: Two-way stopcock
- D: Vent-hole
- E: Suction part of pipet
- F: Mark of 20 cm
- G: Base line of 0 cm
- H: Outlet of pipet
- I: Capillary tube of pipet
- J: Sedimentation tube

Fig. Andreasen pipet

not more than 0.1%.

$$S (\%) = (m_i \times V) / (20 \times M_T) \times 100$$

- M_T : Amount (g) of Calcium Polystyrene Sulfonate taken
- V : Actual volume (mL) to the mark of 20 cm at which the suction part of pipet is inserted

Assay (1) Calcium—Weigh accurately about 1 g of Calcium Polystyrene Sulfonate, previously dried, and disperse in 5 mL of 3 mol/L hydrochloric acid TS. Transfer this mixture, and wash out completely with the aid of a small quantity of 3 mol/L hydrochloric acid TS to a column 12 mm in inside diameter and 70 mm in length, packed with a pledged of fine glass wool in the bottom of it, placing a 50-mL volumetric flask as a receiver under the column. Then collect about 45 mL of eluate, adding 3 mol/L hydrochloric acid TS to the column, and add water to make exactly 50 mL. Pipet 20 mL of this solution, adjust with ammonia TS to a pH of exactly 10. Titrate <2.50> immediately with 0.05 mol/L disodium dihydrogen ethylenediamine tetraacetate VS until the red-purple color of the solution disappears, and a blue color develops (indicator: 0.04 g eriochrome black T-sodium chloride indicator). Perform a blank determination in the same manner, and make any necessary correction.

Each mL of 0.05 mol/L disodium dihydrogen ethylenediamine tetraacetate VS
= 2.004 mg of Ca

(2) Potassium exchange capacity—Pipet 50 mL of Standard Potassium Stock Solution into a glass-stoppered flask containing about 1 g of dried Calcium Polystyrene Sulfonate, accurately weighed, stir for 120 minutes, filter, and discard the first 20 mL of the filtrate. Pipet 5 mL of the subsequent filtrate, and add 0.02 mol/L hydrochloric acid TS to make exactly 100 mL. Pipet 10 mL of this solution, add 0.02 mol/L hydrochloric acid TS to make exactly 1000 mL, and use this solution as the sample solution. Separately, measure exactly a suitable volume of Standard Potassium Stock Solution, dilute with 0.02 mol/L hydrochloric acid TS to make solutions containing 0.5 to 2.5 μg of potassium (K: 39.10) per mL, and use these solutions as the standard solutions. Perform the test with the sample solution and standard solutions as directed under Atomic Absorption Spectrophotometry <2.23> according to the following conditions, and determine the amount, Y (mg), of potassium in 1000 mL of the sample solution, using the calibration curve obtained from the standard solutions. The exchange quantity for potassium per g of dried Calcium Polystyrene Sulfonate is 53 to 71 mg, calculating by the following equation.

$$\begin{aligned} &\text{Exchange quantity (mg) for potassium (K) per g of} \\ &\text{dried Calcium Polystyrene Sulfonate} \\ &= (X - 100 Y) / M \end{aligned}$$

- X : The amount (mg) of potassium in 50 mL of Standard Potassium Stock Solution before exchange
- M : The amount (g) of dried Calcium Polystyrene Sulfonate taken

Gas: Combustible gas—Acetylene.
Supporting gas—Air.

Lamp: A potassium hollow-cathode lamp.
Wavelength: 766.5 nm.

Containers and storage Containers—Tight containers.

Calcium Sodium Edetate Hydrate

エデト酸カルシウムナトリウム水和物

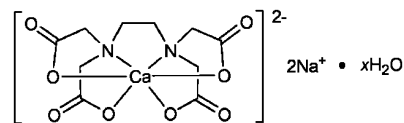

$\text{C}_{10}\text{H}_{12}\text{CaN}_2\text{Na}_2\text{O}_8 \cdot x\text{H}_2\text{O}$
Disodium [[N,N'-ethane-1,2-diybis[N-(carboxymethyl)glycinato]](4-)-N,N',O,O',O^N,O^{N'}]calcate(2-)
hydrate
[23411-34-9]

This monograph is harmonized with the European Pharmacopoeia and the U.S. Pharmacopoeia.

The parts of the text that are not harmonized are marked with symbols (◆ ◆).

Information on the harmonization with the European Pharmacopoeia and the U.S. Pharmacopoeia is available on the website of the Pharmaceuticals and Medical Devices Agency.

Calcium Sodium Edetate Hydrate contains not less than 98.0% and not more than 102.0% of calcium disodium edetate ($\text{C}_{10}\text{H}_{12}\text{CaN}_2\text{Na}_2\text{O}_8$: 374.27), calculated on the anhydrous basis.

◆**Description** Calcium Sodium Edetate Hydrate occurs as

white, powder or particles.

It is freely soluble in water, sparingly soluble in methanol, and practically insoluble in ethanol (99.5).

It is hygroscopic.◆

Identification (1) Dissolve 2 g of Calcium Sodium Edetate Hydrate in 10 mL of water, add 6 mL of a solution of lead (II) nitrate (33 in 1000), shake, and add 3 mL of potassium iodide TS: no yellow precipitate is formed. Make this solution alkaline by the addition of diluted ammonia solution (28) (7 in 50), and add 3 mL of ammonium oxalate TS: a white precipitate is formed.

◆(2) Determine the infrared absorption spectrum of Calcium Sodium Edetate Hydrate as directed in the potassium bromide disk method under Infrared Spectrophotometry <2.25>, and compare the spectrum with the Reference Spectrum: both spectra exhibit similar intensities of absorption at the same wave numbers.◆

(3) A solution of Calcium Sodium Edetate Hydrate (1 in 20) responds to Qualitative Tests <1.09> (2) for sodium salt.

pH <2.54> The pH of a solution of 2.0 g of Calcium Sodium Edetate Hydrate in 10 mL of water is 6.5 to 8.0.

Purity ◆(1) Clarity and color of solution—Dissolve 0.25 g of Calcium Sodium Edetate Hydrate in 10 mL of water: the solution is clear and colorless.◆

(2) Chloride <1.03>—Dissolve 0.70 g of Calcium Sodium Edetate Hydrate in water to make 20 mL. To this solution add 30 mL of dilute nitric acid, allow to stand for 30 minutes, and filter. To 10 mL of the filtrate add water to make 50 mL, and perform the test using this solution as the test solution. Prepare the control solution with 0.40 mL of 0.01 mol/L hydrochloric acid VS (not more than 0.10%).

◆(3) Heavy metals <1.07>—Proceed with 1.0 g of Calcium Sodium Edetate Hydrate according to Method 2, and perform the test. Prepare the control solution with 2.0 mL of Standard Lead Solution (not more than 20 ppm).◆

(4) Disodium edetate—Dissolve 1.00 g of Calcium Sodium Edetate Hydrate in 50 mL of water, add 5 mL of ammonia-ammonium chloride buffer solution (pH 10.7), and titrate <2.50> with 0.01 mol/L magnesium chloride VS until the color of the solution changes from blue to red-purple (indicator: 40 mg of eriochrome black T-sodium chloride indicator): the amount of 0.01 mol/L magnesium chloride VS consumed is not more than 3.0 mL (not more than 1.0%).

◆(5) Nitrilotriacetic acid—Conduct this procedure using light-resistant vessels. Dissolve 0.100 g of Calcium Sodium Edetate Hydrate in diluting solution to make exactly 25 mL, and use this solution as the sample solution. Separately, dissolve 40.0 mg of nitrilotriacetic acid in diluting solution to make exactly 100 mL. Pipet 1 mL of this solution, add 0.1 mL of the sample solution, then add diluting solution to make exactly 100 mL, and use this solution as the standard solution. Perform the test with exactly 20 μL each of the sample solution and standard solution as directed under Liquid Chromatography <2.01> according to the following conditions, and determine the peak areas, A_T and A_S , of nitrilotriacetic acid in each solution: A_T is not larger than A_S (not more than 0.1%).

Diluting solution: Dissolve 10.0 g of iron (III) sulfate *n*-hydrate in 20 mL of 0.5 mol/L sulfuric acid TS and 780 mL of water, adjust to pH 2.0 with sodium hydroxide TS, and add water to make 1000 mL.

Operating conditions—

Detector: An ultraviolet absorption photometer (wavelength: 273 nm).

Column: A stainless steel column 4.6 mm in inside diame-

ter and 10 cm in length, packed with graphite carbon for liquid chromatography (mean pore size: 25 nm, specific surface: 120 m²/g, 5 μm in particle diameter).

Column temperature: A constant temperature of about 40°C.

Mobile phase: Dissolve 50.0 mg of iron (III) sulfate *n*-hydrate in 50 mL of 0.5 mol/L sulfuric acid TS, add 750 mL of water, adjust to pH 1.5 with 0.5 mol/L sulfuric acid TS or sodium hydroxide TS, and add 20 mL of ethylene glycol and water to make 1000 mL.

Flow rate: 1.0 mL per minute (the retention time of nitrilotriacetic acid is about 5 minutes).

System suitability—

Test for required detectability: When perform the test with 20 μL of the standard solution under the above operating conditions, the SN ratio of the peak of nitrilotriacetic acid is not less than 50.

System performance: When the procedure is run with 20 μL of the standard solution under the above operating conditions, nitrilotriacetic acid and edetic acid are eluted in this order with the resolution between these peaks being not less than 7.

System repeatability: When the test is repeated 6 times with 20 μL of the standard solution under the above operating conditions, the relative standard deviation of the peak area of nitrilotriacetic acid is not more than 1.0%.◆

Water <2.48> 5.0 – 13.0% (0.2 g, volumetric titration, direct titration).

Assay Weigh accurately about 0.5 g of Calcium Sodium Edetate Hydrate, and dissolve in water to make exactly 200 mL. Pipet 20 mL of this solution, add 80 mL of water, adjust to pH 2 – 3 with dilute nitric acid, and titrate <2.50> with 0.01 mol/L bismuth nitrate VS until the color of the solution changes from yellow to red (indicator: 2 drops of xylenol orange TS).

Each mL of 0.01 mol/L bismuth nitrate VS
= 3.743 mg of C₁₀H₁₂CaN₂Na₂O₈

◆**Containers and storage** Containers—Tight containers.◆

Calcium Stearate

ステアリン酸カルシウム

Calcium Stearate mainly consists of calcium salts of stearic acid (C₁₈H₃₆O₂: 284.48) and palmitic acid (C₁₆H₃₂O₂: 256.42).

Calcium Stearate, when dried, contains not less than 6.4% and not more than 7.1% of calcium (Ca: 40.08).

Description Calcium Stearate occurs as a white, light, bulky powder. It feels smooth when touched, and is adhesive to the skin. It is odorless or has a faint, characteristic odor.

It is practically insoluble in water, in ethanol (95) and in diethyl ether.

Identification (1) Shake vigorously 3 g of Calcium Stearate with 20 mL of diluted hydrochloric acid (1 in 2) and 30 mL of diethyl ether for 3 minutes, and allow to stand: the separated aqueous layer responds to Qualitative Tests <1.09> (1), (2) and (4) for calcium salt.

(2) Wash the diethyl ether layer obtained in (1) with 20 mL and 10 mL of dilute hydrochloric acid and 20 mL of water successively, and evaporate the diethyl ether on a water bath: the residue melts <1.13> at a temperature not

below 54°C.

Purity (1) Heavy metals <1.07>—Heat gently 1.0 g of Calcium Stearate with caution at the beginning, and heat further, gradually raising the temperature, to incineration. After cooling, add 2 mL of hydrochloric acid, evaporate on a water bath to dryness, warm the residue with 20 mL of water and 2 mL of dilute acetic acid for 2 minutes, cool, filter, and wash the residue with 15 mL of water. Combine the filtrate and the washings, add water to make 50 mL, and perform the test using this solution as the test solution. Prepare the control solution by evaporating 2 mL of hydrochloric acid on a water bath to dryness and by adding 2 mL of dilute acetic acid, 2.0 mL of Standard Lead Solution and water to make 50 mL (not more than 20 ppm).

(2) Arsenic <1.11>—To 1.0 g of Calcium Stearate add 5 mL of diluted hydrochloric acid (1 in 2) and 20 mL of chloroform, shake vigorously for 3 minutes, allow to stand, and separate the water layer. Perform the test with the water layer as the test solution (not more than 2 ppm).

Loss on drying <2.41> Not more than 4.0% (1 g, 105°C, 3 hours).

Assay Weigh accurately about 0.5 g of Calcium Stearate, previously dried, heat gently with caution at first, and then ignite gradually to ash. Cool, add 10 mL of dilute hydrochloric acid to the residue, warm for 10 minutes on a water bath, and transfer the contents to a flask with the aid of 10-mL, 10-mL, and 5-mL portions of hot water. Add sodium hydroxide TS until the solution becomes slightly turbid, and then add 25 mL of 0.05 mol/L disodium dihydrogen ethylenediamine tetraacetate VS, 10 mL of ammonium chloride buffer solution (pH 10.7), 4 drops of eriochrome black T TS and 5 drops of methyl yellow TS, and titrate <2.50> rapidly the excess disodium dihydrogen ethylenediamine tetraacetate with 0.05 mol/L magnesium chloride VS, until the green color of the solution disappears and a red color develops. Perform a blank determination in the same manner.

Each mL of 0.05 mol/L disodium dihydrogen ethylenediamine tetraacetate VS
= 2.004 mg of Ca

Containers and storage Containers—Well-closed containers.

Camostat Mesilate

カモスタットメシル酸塩

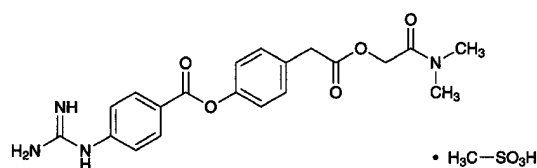

C₂₀H₂₂N₄O₅·CH₄O₃S: 494.52

Dimethylcarbamoylmethyl
4-(4-guanidinobenzoyloxy)phenylacetate
monomethanesulfonate
[59721-29-8]

Camostat Mesilate, when dried, contains not less than 98.5% of camostat mesilate (C₂₀H₂₂N₄O₅·CH₄O₃S).

Description Camostat Mesilate occurs as white, crystals or

crystalline powder.

It is sparingly soluble in water, slightly soluble in ethanol (95), and practically insoluble in diethyl ether.

Identification (1) To 4 mL of a solution of Camostat Mesilate (1 in 2000) add 2 mL of 1-naphthol TS and 1 mL of diacetyl TS, and allow to stand for 10 minutes: a red color develops.

(2) Determine the absorption spectrum of a solution of Camostat Mesilate (1 in 100,000) as directed under Ultraviolet-visible Spectrophotometry <2.24>, and compare the spectrum with the Reference Spectrum or the spectrum of a solution of Camostat Mesilate RS prepared in the same manner as the sample solution: both spectra exhibit similar intensities of absorption at the same wavelengths.

(3) A 0.1 g portion of Camostat Mesilate responds to Qualitative Tests <1.09> (1) for mesilate.

Melting point <2.60> 194 – 198°C

Purity (1) Heavy metals <1.07>—Dissolve 1.0 g of Camostat Mesilate in 40 mL of water by warming, and add 2 mL of dilute acetic acid and water to make 50 mL. Perform the test using this solution as the test solution. Prepare the control solution with 2.0 mL of Standard Lead Solution and 2 mL of dilute acetic acid (not more than 20 ppm).

(2) Arsenic <1.11>—Dissolve 2.0 g of Camostat Mesilate in 20 mL of 2 mol/L hydrochloric acid TS by heating in a water bath, and continue to heat for 20 minutes. After cooling, centrifuge, take 10 mL of the supernatant liquid, and use this solution as the test solution. Perform the test (not more than 2 ppm).

(3) Related substances—Dissolve 30 mg of Camostat Mesilate in 10 mL of ethanol (95), and use this solution as the sample solution. Pipet 1 mL of the sample solution, add ethanol (95) to make exactly 200 mL, and use this solution as the standard solution. Perform the test with these solutions as directed under Thin-layer Chromatography <2.03>. Spot 10 μL each of the sample solution and standard solution on a plate of silica gel for thin-layer chromatography. Develop the plate with a mixture of ethyl acetate, water and acetic acid (100) (3:1:1) to a distance of about 10 cm, and air-dry the plate. Allow the plate to stand overnight in iodine vapor: the spots other than the principal spot obtained from the sample solution are not more intense than the spot from the standard solution.

Loss on drying <2.41> Not more than 1.0% (1 g, silica gel, 105°C, 3 hours).

Residue on ignition <2.44> Not more than 0.2% (1 g).

Assay Weigh accurately about 50 mg each of Camostat Mesilate and Camostat Mesilate RS, previously dried, and dissolve each in water to make exactly 50 mL. Pipet 5 mL each of these solutions, add exactly 5 mL of the internal standard solution, and use these solutions as the sample solution and the standard solution, respectively. Perform the test with 2 μL each of the sample solution and standard solution as directed under Liquid Chromatography <2.01> according to the following conditions, and calculate the ratios, Q_T and Q_S, of the peak area of camostat to that of the internal standard.

Amount (mg) of camostat mesilate (C₂₀H₂₂N₄O₅·CH₄O₃S)
= M_S × Q_T/Q_S

M_S: Amount (mg) of Camostat Mesilate RS taken

Internal standard solution—A solution of butyl parahydroxybenzoate in ethanol (95) (1 in 1500).

Operating conditions—

Detector: An ultraviolet absorption photometer (wavelength: 265 nm).

Column: A stainless steel column 4.6 mm in inside diameter and 15 cm in length, packed with octadecylsilanized silica gel for liquid chromatography (5 μ m in particle diameter).

Column temperature: A constant temperature of about 25°C.

Mobile phase: A mixture of methanol, a solution of sodium 1-heptane sulfonate (1 in 500), a solution of sodium lauryl sulfate (1 in 1000) and acetic acid (100) (200:100:50:1).

Flow rate: Adjust so that the retention time of camostat is about 10 minutes.

System suitability—

System performance: When the procedure is run with 2 μ L of the standard solution under the above operating conditions, camostat and the internal standard are eluted in this order with the resolution between these peaks being not less than 5.

System repeatability: When the test is repeated 6 times with 2 μ L of the standard solution under the above operating conditions, the relative standard deviation of the ratio of the peak area of camostat to that of the internal standard is not more than 1.0%.

Containers and storage Containers—Tight containers.

***d*-Camphor**

d-カンフル

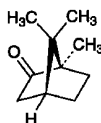

$C_{10}H_{16}O$: 152.23
(1*R*,4*R*)-1,7,7-Trimethylbicyclo[2.2.1]heptan-2-one
[464-49-3]

d-Camphor contains not less than 96.0% of *d*-camphor ($C_{10}H_{16}O$).

Description *d*-Camphor occurs as colorless or white, translucent crystals, crystalline powder or masses. It has a characteristic, agreeable odor, and a slightly bitter taste, followed by a pleasant, cooling sensation.

It is freely soluble in ethanol (95), in diethyl ether and in carbon disulfide, and slightly soluble in water.

It slowly volatilizes at room temperature.

Identification Dissolve 0.1 g of *d*-Camphor in 2 mL of methanol, add 1 mL of 2,4-dinitrophenylhydrazine TS, and heat for 5 minutes on a water bath: an orange-red precipitate is formed.

Optical rotation <2.49> $[\alpha]_D^{20}$: +41.0 – +43.0° (5 g, ethanol (95), 50 mL, 100 mm).

Melting point <2.60> 177 – 182°C

Purity (1) Water—Shake 1.0 g of *d*-Camphor with 10 mL of carbon disulfide: the solution is clear.

(2) Chlorinated compounds—Mix 0.20 g of finely powdered *d*-Camphor with 0.4 g of sodium peroxide in a dried porcelain crucible. Heat the crucible gently by the open flame until the incineration is complete. Dissolve the residue in 20 mL of warm water, acidify with 12 mL of dilute nitric acid, and filter the solution into a Nessler tube. Wash the

filter paper with three 5-mL portions of hot water, adding the washings to the filtrate. After cooling, add water to make 50 mL, then add 1 mL of silver nitrate TS, mix well, and allow to stand for 5 minutes: the turbidity of the solution does not exceed that of the following control solution.

Control solution: Prepare in the same manner as described above, using 0.20 mL of 0.01 mol/L hydrochloric acid VS.

(3) Non-volatile residue—Heat 2.0 g of *d*-Camphor on a water bath until sublimation is complete, then dry the residue at 105°C for 3 hours: the mass of the residue does not exceed 1.0 mg.

Assay Weigh accurately about 0.1 g each of *d*-Camphor and *d*-Camphor RS, add exactly 5 mL each of the internal standard solution, dissolve in ethanol (99.5) to make 100 mL, and use these solutions as the sample solution and the standard solution. Perform the test with 2 μ L each of the sample solution and standard solution as directed under Gas Chromatography <2.02> according to the following conditions, and calculate the ratios, Q_T and Q_S , of the peak area of *d*-camphor to that of the internal standard.

Amount (mg) of *d*-camphor ($C_{10}H_{16}O$) = $M_S \times Q_T/Q_S$

M_S : Amount (mg) of *d*-Camphor RS taken

Internal standard solution—A solution of methyl salicylate in ethanol (99.5) (1 in 25).

Operating conditions—

Detector: A hydrogen flame-ionization detector.

Column: A glass column 3 mm in inside diameter and 3 m in length, which is packed with 10% of polyethylene glycol 20 M for gas chromatography supported on 180 to 250 μ m mesh silanized siliceous earth for gas chromatography.

Column temperature: A constant temperature of about 160°C.

Carrier gas: Nitrogen.

Flow rate: Adjust so that the retention time of *d*-camphor is about 6 minutes.

System suitability—

System performance: When the procedure is run with 2 μ L of the standard solution under the above operating conditions, *d*-camphor and the internal standard are eluted in this order with the resolution between these peaks being not less than 7.

System repeatability: When the test is repeated 6 times with 2 μ L of the standard solution under the above operating conditions, the relative standard deviation of the ratios of the peak area of *d*-camphor to that of the internal standard is not more than 1.0%.

Containers and storage Containers—Tight containers.

***dl*-Camphor**

dl-カンフル

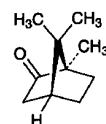

and enantiomer

$C_{10}H_{16}O$: 152.23
(1*RS*,4*RS*)-1,7,7-Trimethylbicyclo[2.2.1]heptan-2-one
[76-22-2]

dl-Camphor contains not less than 96.0% of *dl*-camphor ($C_{10}H_{16}O$).

Description *dl*-Camphor occurs as colorless or white, translucent crystals, crystalline powder or masses. It has a characteristic, agreeable odor, and has a slightly bitter taste followed by a pleasant, cooling sensation.

It is freely soluble in ethanol (95), in diethyl ether and in carbon disulfide, and slightly soluble in water.

It slowly volatilizes at room temperature.

Identification Dissolve 0.1 g of *dl*-Camphor in 2 mL of methanol, add 1 mL of 2,4-dinitrophenylhydrazine TS, and heat for 5 minutes on a water bath: an orange-red precipitate is formed.

Optical rotation <2.49> $[\alpha]_D^{20}$: $-1.5 - +1.5^\circ$ (5 g, ethanol (95), 50 mL, 100 mm).

Melting point <2.60> 175 – 180°C

Purity (1) Water—Shake 1.0 g of *dl*-Camphor with 10 mL of carbon disulfide: the solution is clear.

(2) Chlorinated compounds—Mix 0.20 g of finely powdered *dl*-Camphor with 0.4 g of sodium peroxide in a dried porcelain crucible. Heat the crucible gently by the open flame until the incineration is complete. Dissolve the residue in 20 mL of warm water, acidify with 12 mL of dilute nitric acid, and filter the solution into a Nessler tube. Wash the filter paper with three 5-mL portions of hot water, adding the washings to the filtrate. After cooling, add water to make 50 mL, then add 1 mL of silver nitrate TS, mix well, and allow to stand for 5 minutes: the turbidity of the solution does not exceed that of the following control solution.

Control solution: Prepare in the same manner as described above, using 0.20 mL of 0.01 mol/L hydrochloric acid VS.

(3) Non-volatile residue—Heat 2.0 g of *dl*-Camphor on a water bath until sublimation is complete, then dry the residue at 105°C for 3 hours: the mass of the residue does not exceed 1.0 mg.

Assay Weigh accurately about 0.1 g each of *dl*-Camphor and *dl*-Camphor RS, add exactly 5 mL each of the internal standard solution, dissolve in ethanol (99.5) to make 100 mL, and use these solutions as the sample solution and standard solution, respectively. Perform the test with 2 μ L each of the sample solution and standard solution as directed under Gas Chromatography <2.02> according to the following conditions, and calculate the ratios, Q_T and Q_S , of the peak area of *dl*-camphor to that of the internal standard.

$$\text{Amount (mg) of } dl\text{-camphor (C}_{10}\text{H}_{16}\text{O)} = M_S \times Q_T/Q_S$$

M_S : Amount (mg) of *dl*-Camphor RS taken

Internal standard solution—A solution of methyl salicylate in ethanol (99.5) (1 in 25).

Operating conditions—

Detector: A hydrogen flame-ionization detector.

Column: A glass column 3 mm in inside diameter and 3 m in length, which is packed with 10% of polyethylene glycol 20 M for gas chromatography supported on 180 to 250 μ m mesh silanized siliceous earth for gas chromatography.

Column temperature: A constant temperature of about 160°C.

Carrier gas: Nitrogen.

Flow rate: Adjust so that the retention time of *dl*-camphor is about 6 minutes.

System suitability—

System performance: When the procedure is run with 2 μ L of the standard solution under the above operating conditions, *dl*-camphor and the internal standard are eluted in this order with the resolution between these peaks being not less than 7.

System repeatability: When the test is repeated 6 times with 2 μ L of the standard solution under the above operating conditions, the relative standard deviation of the ratios of the peak area of *dl*-camphor to that of the internal standard is not more than 1.0%.

Containers and storage Containers—Tight containers.

Candesartan Cilexetil

カンデサルタン シレキセチル

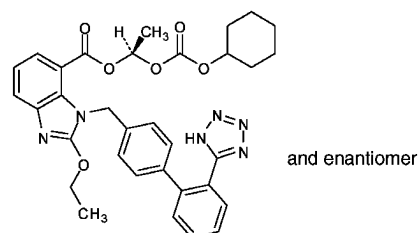

$C_{33}H_{34}N_6O_6$: 610.66

(1*S*)-1-(Cyclohexyloxycarbonyloxy)ethyl-2-ethoxy-1-[2'-(1*H*-tetrazol-5-yl)biphenyl-4-yl]methyl]-1*H*-benzimidazole-7-carboxylate
[145040-37-5]

Candesartan Cilexetil contains not less than 99.0% and not more than 101.0% of candesartan cilexetil ($C_{33}H_{34}N_6O_6$), calculated on the anhydrous basis.

Description Candesartan Cilexetil occurs as white, crystals or crystalline powder.

It is soluble in acetic acid (100), sparingly soluble in methanol, slightly soluble in ethanol (99.5), and practically insoluble in water.

A solution of Candesartan Cilexetil in methanol (1 in 100) shows no optical rotation.

Candesartan Cilexetil shows crystal polymorphism.

Identification (1) Determine the absorption spectrum of a solution of Candesartan Cilexetil in methanol (1 in 50,000) as directed under Ultraviolet-visible Spectrophotometry <2.24>, and compare the spectrum with the Reference Spectrum: both spectra exhibit similar intensities of absorption at the same wavelengths.

(2) Determine the infrared absorption spectrum of Candesartan Cilexetil as directed in the potassium bromide disk method under Infrared Spectrophotometry <2.25>, and compare the spectrum with the Reference Spectrum: both spectra exhibit similar intensities of absorption at the same wave numbers. If any difference appears between the spectra, recrystallize the sample and the RS according to the method otherwise specified, filter and dry the crystals, and perform the test with the crystals.

Purity (1) Heavy metals <1.07>—Proceed with 1.0 g of Candesartan Cilexetil according to Method 4, and perform the test. Prepare the control solution with 2.0 mL of Standard Lead Solution (not more than 20 ppm).

(2) Related substances—Dissolve 20 mg of Candesartan Cilexetil in 50 mL of a mixture of acetonitrile and water (3:2), and use this solution as the sample solution. Pipet 1 mL of the sample solution, add a mixture of acetonitrile and water (3:2) to make exactly 100 mL, and use this solution as the standard solution. Perform the test with exactly 10 μ L each of the sample solution and standard solution as directed under Liquid Chromatography <2.01> according to the fol-

lowing conditions, and determine each peak area by the automatic integration method: the area of the peaks, having the relative retention time of about 0.4 and about 2.0 to candesartan cilexetil, obtained from the sample solution is not larger than 1/5 times the peak area of candesartan cilexetil from the standard solution, the area of the peak, having the relative retention time of about 0.5 to candesartan cilexetil, from the sample solution is not larger than 3/10 times the peak area of candesartan cilexetil from the standard solution, the area of the peak other than candesartan cilexetil and the peaks mentioned above from the sample solution is smaller than 1/10 times the peak area of candesartan cilexetil from the standard solution, and the total area of the peaks other than candesartan cilexetil from the sample solution is not larger than 3/5 times the peak area of candesartan cilexetil from the standard solution.

Operating conditions—

Detector: An ultraviolet absorption photometer (wavelength: 254 nm).

Column: A stainless steel column 4 mm in inside diameter and 15 cm in length, packed with octadecylsilanized silica gel for liquid chromatography (4 μ m in particle diameter).

Column temperature: A constant temperature of about 25°C.

Mobile phase A: A mixture of acetonitrile, water and acetic acid (100) (57:43:1).

Mobile phase B: A mixture of acetonitrile, water and acetic acid (100) (90:10:1).

Flowing of mobile phase: Control the gradient by mixing the mobile phases A and B as directed in the following table.

Time after injection of sample (min)	Mobile phase A (vol%)	Mobile phase B (vol%)
0 - 30	100 → 0	0 → 100

Flow rate: 0.8 mL per minute.

Time span of measurement: For 30 minutes after injection, beginning after the solvent peak.

System suitability—

Test for required detectability: Pipet 2 mL of the standard solution, and add a mixture of acetonitrile and water (3:2) to make exactly 20 mL. Confirm that the peak area of candesartan cilexetil obtained with 10 μ L of this solution is equivalent to 7 to 13% of that with 10 μ L of the standard solution.

System performance: When the procedure is run with 10 μ L of the standard solution under the above operating conditions, the number of theoretical plates and the symmetry factor of the peak of candesartan cilexetil are not less than 12,000 and not more than 1.5, respectively.

System repeatability: When the test is repeated 6 times with 10 μ L of the standard solution under the above operating conditions, the relative standard deviation of the peak area of candesartan cilexetil is not more than 2.0%.

Water <2.48> Not more than 0.3% (0.5 g, coulometric titration).

Residue on ignition <2.44> Not more than 0.1% (1 g).

Assay Weigh accurately about 0.5 g of Candesartan Cilexetil, dissolve in 60 mL of acetic acid (100), and titrate <2.50> with 0.1 mol/L perchloric acid VS (potentiometric titration). Perform a blank determination in the same manner, and make any necessary correction.

Each mL of 0.1 mol/L perchloric acid VS
= 61.07 mg of C₃₃H₃₄N₆O₆

Containers and storage Containers—Well-closed containers.

Candesartan Cilexetil Tablets

カンデサルタン シレキセチル錠

Candesartan Cilexetil Tablets contain not less than 95.0% and not more than 105.0% of the labeled amount of candesartan cilexetil (C₃₃H₃₄N₆O₆; 610.66).

Method of preparation Prepare as directed under Tablets, with Candesartan Cilexetil.

Identification Powder Candesartan Cilexetil Tablets. To a portion of the powder, equivalent to 1 mg of Candesartan Cilexetil, add 50 mL of methanol, shake vigorously for 10 minutes, and filter. Determine the absorption spectrum of the filtrate as directed under Ultraviolet-visible Spectrophotometry <2.24>: it exhibits absorption maxima between 252 nm and 256 nm and between 302 nm and 307 nm.

Purity Related substances—Powder not less than 10 Candesartan Cilexetil Tablets. To a portion of the powder, equivalent to 6 mg of Candesartan Cilexetil, add 15 mL of a mixture of acetonitrile and water (3:2), shake vigorously for 10 minutes, and centrifuge. Filter the supernatant liquid through a membrane filter with a pore size not exceeding 0.45 μ m. Discard the first 3 mL of the filtrate, and use the subsequent filtrate as the sample solution. Pipet 1 mL of the sample solution, add a mixture of acetonitrile and water (3:2) to make exactly 100 mL, and use this solution as the standard solution. Perform the test with exactly 10 μ L each of the sample solution and standard solution as directed under Liquid Chromatography <2.01> according to the following conditions, and determine each peak area by the automatic integration method: the area of the peak having the relative retention time of about 0.5 to candesartan cilexetil obtained from the sample solution is not larger than 1.5 times the peak area of candesartan cilexetil from the standard solution, the area of the peak having the relative retention time of about 0.8, about 1.1 and about 1.5 to candesartan cilexetil from the sample solution is not larger than 1/2 times the peak area of candesartan cilexetil from the standard solution, the area of the peak having the relative retention time of about 2.0 to candesartan cilexetil from the sample solution is not larger than the peak area of candesartan cilexetil from the standard solution, the area of the peak other than candesartan cilexetil, the peak having the relative retention time of about 0.4 to candesartan cilexetil and the peaks mentioned above from the sample solution is smaller than 1/10 times the peak area of candesartan cilexetil from the standard solution, and the total area of the peaks other than candesartan cilexetil from the sample solution is not larger than 4 times the peak area of candesartan cilexetil from the standard solution.

Operating conditions—

Detector: An ultraviolet absorption photometer (wavelength: 254 nm).

Column: A stainless steel column 3.9 mm in inside diameter and 15 cm in length, packed with octadecylsilanized silica gel for liquid chromatography (4 μ m in particle diameter).

Column temperature: A constant temperature of about 25°C.

Mobile phase A: A mixture of acetonitrile, water and acetic acid (100) (57:43:1).

Mobile phase B: A mixture of acetonitrile, water and acetic acid (100) (90:10:1).

Flowing of mobile phase: Control the gradient by mixing the mobile phases A and B as directed in the following table.

Time after injection of sample (min)	Mobile phase A (vol%)	Mobile phase B (vol%)
0 - 30	100 → 0	0 → 100

Flow rate: 0.8 mL per minute.

Time span of measurement: For 30 minutes after injection, beginning after the solvent peak.

System suitability—

Test for required detectability: Pipet 2 mL of the standard solution, and add a mixture of acetonitrile and water (3:2) to make exactly 20 mL. Confirm that the peak area of candesartan cilexetil obtained with 10 μ L of this solution is equivalent to 7 to 13% of that with 10 μ L of the standard solution.

System performance: When the procedure is run with 10 μ L of the standard solution under the above operating conditions, the number of theoretical plates and the symmetry factor of the peak of candesartan cilexetil are not less than 12,000 and not more than 1.5, respectively.

System repeatability: When the test is repeated 6 times with 10 μ L of the standard solution under the above operating conditions, the relative standard deviation of the peak area of candesartan cilexetil is not more than 2.0%.

Uniformity of dosage units <6.02> Perform the test according to the following method: it meets the requirement of the Content uniformity test.

To 1 tablet of Candesartan Cilexetil Tablets add 30 mL of a mixture of acetonitrile and water (3:2), shake vigorously for 20 minutes, then add a mixture of acetonitrile and water (3:2) to make exactly V mL so that each mL contains about 40 μ g of candesartan cilexetil ($C_{33}H_{34}N_6O_6$), centrifuge, and use the supernatant liquid as the sample solution. Separately, weigh accurately about 50 mg of candesartan cilexetil for assay (separately determine the water <2.48> in the same manner as Candesartan Cilexetil), and dissolve in acetonitrile to make exactly 50 mL. Pipet 4 mL of this solution, add a mixture of acetonitrile and water (3:2) to make exactly 100 mL, and use this solution as the standard solution. Determine the absorbances, A_T and A_S , of the sample solution and standard solution at 305 nm as directed under Ultraviolet-visible Spectrophotometry <2.24>.

$$\begin{aligned} &\text{Amount (mg) of candesartan cilexetil (C}_{33}\text{H}_{34}\text{N}_6\text{O}_6) \\ &= M_S \times A_T/A_S \times V/1250 \end{aligned}$$

M_S : Amount (mg) of candesartan cilexetil for assay taken, calculated on the anhydrous basis

Dissolution <6.10> When the test is performed at 50 revolutions per minute according to the Paddle method, using 900 mL of a solution of polysorbate 20 (1 in 100) as the dissolution medium, the dissolution rate in 45 minutes of Candesartan Cilexetil Tablets is not less than 75%.

Start the test with 1 tablet of Candesartan Cilexetil Tablets, withdraw not less than 20 mL of the medium at the specified minute after starting the test, and filter through a membrane filter with a pore size not exceeding 0.45 μ m. Discard not less than 5 mL of the first filtrate, pipet V mL of the subsequent filtrate, add the dissolution medium to make

exactly V' mL so that each mL contains about 2.2 μ g of candesartan cilexetil ($C_{33}H_{34}N_6O_6$), and use this solution as the sample solution. Separately, weigh accurately about 50 mg of candesartan cilexetil for assay (separately determine the water <2.48> in the same manner as Candesartan Cilexetil), and dissolve in acetonitrile to make exactly 50 mL. Pipet 5 mL of this solution, add acetonitrile to make exactly 50 mL. Pipet 1 mL of this solution, add the dissolution medium to make exactly 50 mL, and use this solution as the standard solution. Perform the test with exactly 50 μ L each of the sample solution and standard solution as directed under Liquid Chromatography <2.01>, and determine the peak areas, A_T and A_S , of candesartan cilexetil in each solution.

$$\begin{aligned} &\text{Dissolution rate (\%)} \text{ with respect to the labeled amount} \\ &\text{of candesartan cilexetil (C}_{33}\text{H}_{34}\text{N}_6\text{O}_6) \\ &= M_S \times A_T/A_S \times V'/V \times 1/C \times 18/5 \end{aligned}$$

M_S : Amount (mg) of candesartan cilexetil for assay taken, calculated on the anhydrous basis

C : Labeled amount (mg) of candesartan cilexetil ($C_{33}H_{34}N_6O_6$) in 1 tablet

Operating conditions—

Proceed as directed in the operating conditions in the Assay.

System suitability—

System performance: When the procedure is run with 50 μ L of the standard solution under the above operating conditions, the number of theoretical plates and the symmetry factor of the peak of candesartan cilexetil are not less than 7000 and not more than 1.5, respectively.

System repeatability: When the test is repeated 6 times with 50 μ L of the standard solution under the above operating conditions, the relative standard deviation of the peak area of candesartan cilexetil is not more than 2.0%.

Assay Weigh accurately the mass of not less than 20 Candesartan Cilexetil Tablets, and powder. Weigh accurately a portion of the powder, equivalent to about 6 mg of candesartan cilexetil ($C_{33}H_{34}N_6O_6$), add exactly 15 mL of the internal standard solution, then add a mixture of acetonitrile and water (3:2) to make 150 mL, shake vigorously for 10 minutes, and allow to stand. Filter the supernatant liquid through a membrane filter with a pore size not exceeding 0.45 μ m. Discard the first 5 mL of the filtrate, and use the subsequent filtrate as the sample solution. Separately, weigh accurately about 50 mg of candesartan cilexetil for assay (separately determine the water <2.48> in the same manner as Candesartan Cilexetil), dissolve in acetonitrile to make exactly 50 mL. Pipet 4 mL of this solution, add exactly 10 mL of the internal standard solution, then add a mixture of acetonitrile and water (3:2) to make 100 mL, and use this solution as the standard solution. Perform the test with 10 μ L each of the sample solution and standard solution as directed under Liquid Chromatography <2.01> according to the following conditions, and calculate the ratios, Q_T and Q_S , of the peak area of candesartan cilexetil to that of the internal standard.

$$\begin{aligned} &\text{Amount (mg) of candesartan cilexetil (C}_{33}\text{H}_{34}\text{N}_6\text{O}_6) \\ &= M_S \times Q_T/Q_S \times 3/25 \end{aligned}$$

M_S : Amount (mg) of candesartan cilexetil for assay taken, calculated on the anhydrous basis

Internal standard solution—A solution of acenaphthene in acetonitrile (1 in 800).

Operating conditions—

Detector: An ultraviolet absorption photometer (wave-

length: 254 nm).

Column: A stainless steel column 3.9 mm in inside diameter and 15 cm in length, packed with octadecylsilanized silica gel for liquid chromatography (4 μm in particle diameter).

Column temperature: A constant temperature of about 25°C.

Mobile phase: A mixture of acetonitrile, water and acetic acid (100) (57:43:1).

Flow rate: Adjust so that the retention time of candesartan cilexetil is about 13 minutes.

System suitability—

System performance: When the procedure is run with 10 μL of the standard solution under the above operating conditions, the internal standard and candesartan cilexetil are eluted in this order with the resolution between these peaks being not less than 5.

System repeatability: When the test is repeated 6 times with 10 μL of the standard solution under the above operating conditions, the relative standard deviation of the ratio of the peak area of candesartan cilexetil to that of the internal standard is not more than 1.0%.

Containers and storage Containers—Tight containers.

Candesartan Cilexetil and Amlodipine Besylate Tablets

カンデサルタン シレキセチル・アムロジピンベシル酸塩錠

Candesartan Cilexetil and Amlodipine Besylate Tablets contain not less than 95.0% and not more than 105.0% of the labeled amount of candesartan cilexetil ($\text{C}_{33}\text{H}_{34}\text{N}_6\text{O}_6$; 610.66) and amlodipine besylate ($\text{C}_{20}\text{H}_{25}\text{ClN}_2\text{O}_5 \cdot \text{C}_6\text{H}_6\text{O}_3\text{S}$; 567.05).

Method of preparation Prepare as directed under Tablets, with Candesartan Cilexetil and Amlodipine Besylate.

Identification (1) Shake thoroughly a quantity of powdered Candesartan Cilexetil and Amlodipine Besylate Tablets, equivalent to 8 mg of Candesartan Cilexetil, with 20 mL of 0.01 mol/L hydrochloric acid TS, and centrifuge. Remove the supernatant liquid, to the residue add 20 mL of 0.01 mol/L hydrochloric acid TS, shake thoroughly, and centrifuge. Remove the supernatant liquid, to the residue add 40 mL of methanol, shake thoroughly, and filter through a membrane filter with a pore size not exceeding 0.45 μm . To 5 mL of the filtrate add methanol to make 50 mL, and determine the absorption spectrum of this solution as directed under Ultraviolet-visible Spectrophotometry <2.24>: it exhibits maxima between 252 nm and 256 nm, and between 302 nm and 307 nm.

(2) Shake thoroughly a quantity of powdered Candesartan Cilexetil and Amlodipine Besylate Tablets, equivalent to 2.5 mg of Amlodipine Besylate, with 20 mL of 0.01 mol/L hydrochloric acid TS, and centrifuge. Filter the supernatant liquid through a membrane filter with a pore size not exceeding 0.45 μm . To 5 mL of the filtrate add methanol to make 25 mL, and determine the absorption spectrum of this solution as directed under Ultraviolet-visible Spectrophotometry <2.24>: it exhibits maxima between 236 nm and 240 nm, and between 360 nm and 364 nm.

Purity Related substances—Shake vigorously for 20 minutes a quantity of powdered Candesartan Cilexetil and Amlodipine Besylate Tablets, equivalent to 8 mg of Candesartan Cilexetil, with 20 mL of diluting solution, and filter

this solution through a membrane filter with a pore size not exceeding 0.45 μm . Discard the first 5 mL of the filtrate, and use the subsequent filtrate as the sample solution. Pipet 1 mL of the sample solution, add diluting solution to make exactly 100 mL, and use this solution as the standard solution. Perform the test with exactly 20 μL each of the sample solution and standard solution as directed under Liquid Chromatography <2.01> according to the following conditions. Determine each peak area by the automatic integration method: the area of the peak, having the relative retention time of about 0.8 to candesartan cilexetil, obtained from the sample solution is not larger than 1.5 times the peak area of candesartan cilexetil from the standard solution, the area of the peaks, having a relative retention time of about 0.9, about 1.1 and about 1.2 from the sample solution is not larger than 1/2 times the peak area of candesartan cilexetil from the standard solution, the area of the peak, having a relative retention time of about 1.4 from the sample solution, is not larger than the peak area of candesartan cilexetil from the standard solution, and the area of the peak other than candesartan cilexetil and the peaks mentioned above from the sample solution is smaller than 1/10 times the peak area of candesartan cilexetil from the standard solution. Furthermore, the total area of the peaks other than candesartan cilexetil from the sample solution is not larger than 4 times the peak area of candesartan cilexetil from the standard solution.

Diluting solution: To 3.5 mL of triethylamine add water to make 500 mL, and adjust to pH 3.0 with phosphoric acid. To 400 mL of this solution add 600 mL of acetonitrile.

Operating conditions—

Detector: An ultraviolet absorption photometer (wavelength: 253 nm).

Column: A stainless steel column 4.6 mm in inside diameter and 15 cm in length, packed with octadecylsilanized silica gel for liquid chromatography (5 μm in particle diameter).

Column temperature: A constant temperature of about 25°C.

Mobile phase A: A mixture of water, acetonitrile and trifluoroacetic acid (4000:1000:1).

Mobile phase B: A mixture of acetonitrile, water and trifluoroacetic acid (4000:1000:1).

Flowing of mobile phase: Control the gradient by mixing the mobile phases A and B as directed in the following table.

Time after injection of sample (min)	Mobile phase A (vol%)	Mobile phase B (vol%)
0 – 15	100 → 50	0 → 50
15 – 50	50 → 0	50 → 100
50 – 60	0	100

Flow rate: 1.0 mL per minute.

Time span of measurement: For 60 minutes after injection, beginning after the solvent peak.

System suitability—

Test for required detectability: To exactly 1 mL of the standard solution add diluting solution to make exactly 50 mL. Confirm that the peak area of candesartan cilexetil obtained with 20 μL of this solution is equivalent to 1.4 to 2.6% of that obtained with 20 μL of the standard solution.

System performance: When the procedure is run with 20 μL of the standard solution under the above operating conditions, the number of theoretical plates and the symmetry factor of the peak of candesartan cilexetil are not less than 100,000 and not more than 1.5, respectively.

System repeatability: When the test is repeated 6 times with 20 μL of the standard solution under the above operating conditions, the relative standard deviation of the peak area of candesartan cilexetil is not more than 2.0%.

Uniformity of dosage units <6.02> Perform the test according to the following methods: it meets the requirements of the Content uniformity test.

(1) Candesartan cilexetil—To 1 tablet of Candesartan Cilexetil and Amlodipine Besylate Tablets add exactly 20 mL of diluting solution, shake for 20 minutes to disintegrate the tablet, and filter through a membrane filter with a pore size not exceeding 0.45 μm . Discard the first 5 mL of the filtrate, pipet V mL of the subsequent filtrate, add exactly $V'/5$ mL of the internal standard solution, then add diluting solution to make V' mL so that each mL contains about 0.16 mg of candesartan cilexetil ($\text{C}_{33}\text{H}_{34}\text{N}_6\text{O}_6$), and use this solution as the sample solution. Then, proceed as directed in the Assay (1).

$$\begin{aligned} &\text{Amount (mg) of candesartan cilexetil (C}_{33}\text{H}_{34}\text{N}_6\text{O}_6) \\ &= M_S \times Q_T/Q_S \times V'/V \times 2/25 \end{aligned}$$

M_S : Amount (mg) of candesartan cilexetil for assay taken, calculated on the anhydrous basis

Internal standard solution—A solution of butyl parahydroxybenzoate in diluting solution (1 in 2500).

Diluting solution: To 3.5 mL of triethylamine add water to make 500 mL, and adjust to pH 3.0 with phosphoric acid. To 400 mL of this solution add 600 mL of acetonitrile.

(2) Amlodipine besylate—To 1 tablet of Candesartan Cilexetil and Amlodipine Besylate Tablets add exactly 20 mL of diluting solution, shake for 20 minutes to disintegrate the tablet, and filter through a membrane filter with a pore size not exceeding 0.45 μm . Discard the first 5 mL of the filtrate, pipet V mL of the subsequent filtrate, add exactly $V'/5$ mL of the internal standard solution, then add diluting solution to make V' mL so that each mL contains about 70 μg of amlodipine besylate ($\text{C}_{20}\text{H}_{25}\text{ClN}_2\text{O}_5 \cdot \text{C}_6\text{H}_6\text{O}_3\text{S}$), and use this solution as the sample solution. Then, proceed as directed in the Assay (2).

$$\begin{aligned} &\text{Amount (mg) of amlodipine besylate} \\ &(\text{C}_{20}\text{H}_{25}\text{ClN}_2\text{O}_5 \cdot \text{C}_6\text{H}_6\text{O}_3\text{S}) \\ &= M_S \times Q_T/Q_S \times V'/V \times 1/25 \end{aligned}$$

M_S : Amount (mg) of Amlodipine Besylate RS taken, calculated on the anhydrous basis

Internal standard solution—A solution of butyl parahydroxybenzoate in diluting solution (1 in 2500).

Diluting solution: To 3.5 mL of triethylamine add water to make 500 mL, and adjust to pH 3.0 with phosphoric acid. To 400 mL of this solution add 600 mL of acetonitrile.

Dissolution <6.10> (1) Candesartan cilexetil—When the test is performed at 75 revolutions per minute according to the Paddle method, using 900 mL of a solution, prepared by dissolving 1 g of polysorbate 80 in 2nd fluid for dissolution test to make 1000 mL, as the dissolution medium, the dissolution rate in 45 minutes of Candesartan Cilexetil and Amlodipine Besylate Tablets is not less than 80%.

Start the test with 1 tablet of Candesartan Cilexetil and Amlodipine Besylate Tablets, withdraw not less than 10 mL of the medium at the specified minute after starting the test, and filter through a membrane filter with a pore size not exceeding 0.45 μm . Discard not less than 5 mL of the first filtrate, pipet V mL of the subsequent filtrate, add the dissolution medium to make exactly V' mL so that each mL contains about 8.9 μg of candesartan cilexetil ($\text{C}_{33}\text{H}_{34}\text{N}_6\text{O}_6$), and

use this solution as the sample solution. Separately, weigh accurately about 45 mg of candesartan cilexetil for assay (separately, determine the water <2.48> in the same manner as Candesartan Cilexetil), and dissolve in acetonitrile to make exactly 50 mL. Pipet 1 mL of this solution, add the dissolution medium to make exactly 100 mL, and use this solution as the standard solution. Perform the test with exactly 20 μL each of the sample solution and standard solution as directed under Liquid Chromatography <2.01> according to the following conditions, and determine the peak areas, A_T and A_S , of candesartan cilexetil in each solution.

$$\begin{aligned} &\text{Dissolution rate (\%)} \text{ with respect to the labeled amount} \\ &\text{of candesartan cilexetil (C}_{33}\text{H}_{34}\text{N}_6\text{O}_6) \\ &= M_S \times A_T/A_S \times V'/V \times 1/C \times 18 \end{aligned}$$

M_S : Amount (mg) of candesartan cilexetil for assay taken, calculated on the anhydrous basis

C : Labeled amount (mg) of candesartan cilexetil ($\text{C}_{33}\text{H}_{34}\text{N}_6\text{O}_6$) in 1 tablet

Operating conditions—

Detector: An ultraviolet absorption photometer (wavelength: 254 nm).

Column: A stainless steel column 4.6 mm in inside diameter and 5 cm in length, packed with octadecylsilanized silica gel for liquid chromatography (5 μm in particle diameter).

Column temperature: A constant temperature of about 25°C.

Mobile phase: A mixture of acetonitrile, water and acetic acid (100) (57:43:1).

Flow rate: Adjust so that the retention time of candesartan cilexetil is about 6.5 minutes.

System suitability—

System performance: When the procedure is run with 20 μL of the standard solution under the above operating conditions, the number of theoretical plates and the symmetry factor of the peak of candesartan cilexetil are not less than 2000 and not more than 1.5, respectively.

System repeatability: When the test is repeated 6 times with 20 μL of the standard solution under the above operating conditions, the relative standard deviation of the peak area of candesartan cilexetil is not more than 1.0%.

(2) Amlodipine besylate—When the test is performed at 50 revolutions per minute according to the Paddle method, using 900 mL of 0.05 mol/L acetic acid-sodium acetate buffer solution (pH 4.0) as the dissolution medium, the dissolution rate in 30 minutes of Candesartan Cilexetil and Amlodipine Besylate Tablets is not less than 80%.

Start the test with 1 tablet of Candesartan Cilexetil and Amlodipine Besylate Tablets, withdraw not less than 10 mL of the medium at the specified minute after starting the test, and filter through a membrane filter with a pore size not exceeding 0.45 μm . Discard not less than 5 mL of the first filtrate, pipet V mL of the subsequent filtrate, add the dissolution medium to make exactly V' mL so that each mL contains about 3.9 μg of amlodipine besylate ($\text{C}_{20}\text{H}_{25}\text{ClN}_2\text{O}_5 \cdot \text{C}_6\text{H}_6\text{O}_3\text{S}$), and use this solution as the sample solution. Separately, weigh accurately about 39 mg of Amlodipine Besylate RS (separately, determine the water <2.48> in the same manner as Amlodipine Besylate), and dissolve in acetonitrile to make exactly 50 mL. Pipet 5 mL of this solution, add acetonitrile to make exactly 50 mL. Pipet 5 mL of this solution, add the dissolution medium to make exactly 100 mL, and use this solution as the standard solution. Perform the test with exactly 50 μL each of the sample solution and standard solution as directed under Liquid Chromatography <2.01> according to the following conditions, and determine

the peak areas, A_T and A_S , of amlodipine in each solution.

Dissolution rate (%) with respect to the labeled amount of amlodipine besylate ($C_{20}H_{25}ClN_2O_5 \cdot C_6H_6O_3S$)

$$= M_S \times A_T / A_S \times V' / V \times 1 / C \times 9$$

M_S : Amount (mg) of Amlodipine Besylate RS taken, calculated on the anhydrous basis

C: Labeled amount (mg) of amlodipine besylate ($C_{20}H_{25}ClN_2O_5 \cdot C_6H_6O_3S$) in 1 tablet

Operating conditions—

Detector, column, column temperature, and mobile phase: Proceed as directed in the operating conditions in the Assay (1).

Flow rate: Adjust so that the retention time of amlodipine is about 4 minutes.

System suitability—

System performance: When the procedure is run with 50 μ L of the standard solution under the above operating conditions, the number of theoretical plates and the symmetry factor of the peak of amlodipine are not less than 3000 and not more than 2.0, respectively.

System repeatability: When the test is repeated 6 times with 50 μ L of the standard solution under the above operating conditions, the relative standard deviation of the peak area of amlodipine is not more than 1.0%.

Assay (1) Candesartan cilexetil—Weigh accurately the mass of not less than 20 Candesartan Cilexetil and Amlodipine Besylate Tablets, and powder. Weigh accurately a portion of the powder, equivalent to about 8 mg of candesartan cilexetil ($C_{33}H_{34}N_6O_6$), add exactly 20 mL of diluting solution, shake vigorously for 20 minutes, and filter through a membrane filter with a pore size not exceeding 0.45 μ m. Discard the first 5 mL of the filtrate, pipet 10 mL of the subsequent filtrate, add exactly 5 mL of the internal standard solution, then add diluting solution to make 25 mL, and use this solution as the sample solution. Separately, weigh accurately about 40 mg of candesartan cilexetil for assay (separately, determine the water <2.48> in the same manner as Candesartan Cilexetil), dissolve in diluting solution to make exactly 100 mL, and use this solution as the candesartan cilexetil standard stock solution. Pipet 10 mL of the candesartan cilexetil standard stock solution, add exactly 5 mL of the internal standard solution, then add diluting solution to make 25 mL, and use this solution as the standard solution. Perform the test with 10 μ L each of the sample solution and standard solution as directed under Liquid Chromatography <2.01> according to the following conditions, and calculate the ratios, Q_T and Q_S , of the peak area of candesartan cilexetil to that of the internal standard.

Amount (mg) of candesartan cilexetil ($C_{33}H_{34}N_6O_6$)

$$= M_S \times Q_T / Q_S \times 1/5$$

M_S : Amount (mg) of candesartan cilexetil for assay taken, calculated on the anhydrous basis

Internal standard solution—A solution of butyl parahydroxybenzoate in diluting solution (1 in 2500).

Diluting solution: To 3.5 mL of triethylamine add water to make 500 mL, and adjust to pH 3.0 with phosphoric acid. To 400 mL of this solution add 600 mL of acetonitrile.

Operating conditions—

Detector: An ultraviolet absorption photometer (wavelength: 238 nm).

Column: A stainless steel column 3.9 mm in inside diameter and 15 cm in length, packed with octadecylsilanized silica gel for liquid chromatography (5 μ m in particle diameter).

Column temperature: A constant temperature of about 25°C.

Mobile phase: To 7 mL of triethylamine add water to make 1000 mL, and adjust to pH 6.5 with phosphoric acid. To 800 mL of this solution add 500 mL of acetonitrile.

Flow rate: Adjust so that the retention time of candesartan cilexetil is about 31 minutes.

System suitability—

System performance: Mix 10 mL of the candesartan cilexetil standard stock solution and 5 mL of the amlodipine besylate standard stock solution prepared in the Assay (2), add 5 mL of the internal standard solution, then add diluting solution to make 25 mL. When the procedure is run with 10 μ L of this solution under the above operating conditions, amlodipine, the internal standard and candesartan cilexetil are eluted in this order and the resolution between the peaks of the internal standard and candesartan cilexetil is not less than 15.

System repeatability: When the test is repeated 6 times with 10 μ L of the standard solution under the above operating conditions, the relative standard deviation of the ratio of the peak area of candesartan cilexetil to that of the internal standard is not more than 1.0%.

(2) Amlodipine besylate—Weigh accurately the mass of not less than 20 Candesartan Cilexetil and Amlodipine Besylate Tablets, and powder. Weigh accurately a portion of the powder, equivalent to about 3.5 mg of amlodipine besylate ($C_{20}H_{25}ClN_2O_5 \cdot C_6H_6O_3S$), add exactly 20 mL of diluting solution, shake vigorously for 20 minutes, and filter through a membrane filter with a pore size not exceeding 0.45 μ m. Discard the first 5 mL of the filtrate, pipet 10 mL of the subsequent filtrate, add exactly 5 mL of the internal standard solution, then add diluting solution to make 25 mL, and use this solution as the sample solution. Separately, weigh accurately about 35 mg of Amlodipine Besylate RS (separately, determine the water <2.48> in the same manner as Amlodipine Besylate), dissolve in diluting solution to make exactly 100 mL, and use this solution as the amlodipine besylate standard stock solution. Pipet 5 mL of the amlodipine besylate standard stock solution, add exactly 5 mL of the internal standard solution, then add diluting solution to make 25 mL, and use this solution as the standard solution. Perform the test with 10 μ L each of the sample solution and standard solution as directed under Liquid Chromatography <2.01> according to the following conditions, and calculate the ratios, Q_T and Q_S , of the peak area of amlodipine to that of the internal standard.

Amount (mg) of amlodipine besylate ($C_{20}H_{25}ClN_2O_5 \cdot C_6H_6O_3S$)

$$= M_S \times Q_T / Q_S \times 1/10$$

M_S : Amount (mg) of Amlodipine Besylate RS taken, calculated on the anhydrous basis

Internal standard solution—A solution of butyl parahydroxybenzoate in diluting solution (1 in 2500).

Diluting solution: To 3.5 mL of triethylamine add water to make 500 mL, and adjust to pH 3.0 with phosphoric acid. To 400 mL of this solution add 600 mL of acetonitrile.

Operating conditions—

Detector, column, column temperature, and mobile phase: Proceed as directed in the operating conditions in the Assay (1).

Flow rate: Adjust so that the retention time of amlodipine is about 2.5 minutes.

System suitability—

System performance: Mix 10 mL of the candesartan cilex-

etil standard stock solution prepared in the Assay (1) and 5 mL of the amlodipine besylate standard stock solution, add 5 mL of the internal standard solution, then add diluting solution to make 25 mL. When the procedure is run with 10 μ L of this solution under the above operating conditions, amlodipine, the internal standard and candesartan cilexetil are eluted in this order and the resolution between the peaks of amlodipine and the internal standard is not less than 15.

System repeatability: When the test is repeated 6 times with 10 μ L of the standard solution under the above operating conditions, the relative standard deviation of the ratio of the peak area of amlodipine to that of the internal standard is not more than 1.0%.

Containers and storage Containers—Tight containers.

Candesartan Cilexetil and Hydrochlorothiazide Tablets

カンデサルタン シレキセチル・ヒドロクロロチアジド錠

Candesartan Cilexetil and Hydrochlorothiazide Tablets contain not less than 95.0% and not more than 105.0% of the labeled amount of candesartan cilexetil ($C_{33}H_{34}N_6O_6$: 610.66) and hydrochlorothiazide ($C_7H_8ClN_3O_4S_2$: 297.74).

Method of preparation Prepare as directed under Tablets, with Candesartan Cilexetil and Hydrochlorothiazide.

Identification (1) To an amount of powdered Candesartan Cilexetil and Hydrochlorothiazide Tablets, equivalent to 4 mg of Candesartan Cilexetil, add 5 mL of acetone, shake thoroughly, centrifuge, and filter the supernatant liquid through a membrane filter with a pore size not exceeding 0.45 μ m. Evaporate the filtrate to dryness with the aid of a current of nitrogen. Dissolve the residue in 0.5 mL of acetone, and use this solution as the sample solution. Separately, dissolve 40 mg of candesartan cilexetil in 5 mL of acetone, and use this solution as the standard solution. Perform the test with these solutions as directed under Thin-layer Chromatography <2.03>. Spot 2 μ L each of the sample solution and standard solution on a plate of silica gel with fluorescent indicator for thin-layer chromatography. Develop the plate with a mixture of ethyl acetate and acetic acid (100) (10:1) to a distance of about 10 cm, and air-dry the plate. Examine under ultraviolet light (main wavelength: 254 nm): the *R_f* value of the spot having a larger *R_f* value among the spots obtained from the sample solution is the same with that of the spot from the standard solution.

(2) To an amount of powdered Candesartan Cilexetil and Hydrochlorothiazide Tablets, equivalent to 6.25 mg of Hydrochlorothiazide, add 5 mL of acetone, shake thoroughly, centrifuge, and filter the supernatant liquid through a membrane filter with a pore size not exceeding 0.45 μ m. Evaporate the filtrate to dryness with the aid of a current of nitrogen. Dissolve the residue in 0.5 mL of acetone, and use this solution as the sample solution. Separately, dissolve 50 mg of hydrochlorothiazide in 4 mL of acetone, and use this solution as the standard solution. Perform the test with these solutions as directed under Thin-layer Chromatography <2.03>. Spot 2 μ L each of the sample solution and standard solution on a plate of silica gel with fluorescent indicator for thin-layer chromatography. Develop the plate with a mixture of ethyl acetate and acetic acid (100) (10:1) to a distance of about 10 cm, and air-dry the plate. Examine under ultraviolet

light (main wavelength: 254 nm): the *R_f* value of the spot having a smaller *R_f* value among the spots obtained from the sample solution is the same with that of the spot from the standard solution.

Purity Related substances—(i) To an amount of powdered Candesartan Cilexetil and Hydrochlorothiazide Tablets, equivalent to 4 mg of Candesartan Cilexetil, add 10 mL of a mixture of acetonitrile and water (3:2), shake vigorously for 10 minutes, centrifuge, and filter the supernatant liquid through a membrane filter with a pore size not exceeding 0.45 μ m. Discard the first 5 mL of the filtrate, and use the subsequent filtrate as the sample solution. Pipet 1 mL of the sample solution, add a mixture of acetonitrile and water (3:2) to make exactly 100 mL, and use this solution as the standard solution. Perform the test with exactly 10 μ L each of the sample solution and standard solution as directed under Liquid Chromatography <2.01> according to the following conditions, and determine each peak area by the automatic integration method: the area of the peak, having a relative retention time of about 0.5 to candesartan cilexetil, obtained from the sample solution is not larger than 1.5 times the peak area of candesartan cilexetil from the standard solution, the area of the peak, having a relative retention time of about 0.8, about 1.1 and about 1.5, from the sample solution is not larger than 1/2 times the peak area of candesartan cilexetil from the standard solution, the area of the peak, having a relative retention time of about 2.0, from the sample solution is not larger than the peak area of candesartan cilexetil from the standard solution, and the area of the peak, other than candesartan cilexetil and the peaks mentioned above, from the sample solution is smaller than 1/10 times the peak area of candesartan cilexetil from the standard solution. Furthermore, the total area of the peaks other than candesartan cilexetil from the sample solution is not larger than 4 times the peak area of candesartan cilexetil from the standard solution.

Operating conditions—

Detector, column, column temperature, mobile phases A and B, flowing of mobile phase, and time span of measurement: Proceed as directed in the operating conditions in the Purity (2) under Candesartan Cilexetil.

Flow rate: 0.6 mL per minute.

System suitability—

Test for required detectability: To exactly 1 mL of the standard solution add a mixture of acetonitrile and water (3:2) to make exactly 50 mL. Confirm that the peak area of candesartan cilexetil obtained with 10 μ L of this solution is equivalent to 1.4% to 2.6% of that with 10 μ L of the standard solution.

System performance: When the procedure is run with 10 μ L of the standard solution under the above operating conditions, the number of theoretical plates and the symmetry factor of the peak of candesartan cilexetil are not less than 12,000 and not more than 1.5, respectively.

System repeatability: When the test is repeated 6 times with 10 μ L of the standard solution under the above operating conditions, the relative standard deviation of the peak area of candesartan cilexetil is not more than 2.0%.

(ii) To an amount of powdered Candesartan Cilexetil and Hydrochlorothiazide Tablets, equivalent to 6.25 mg of Hydrochlorothiazide, add 10 mL of a mixture of 0.05 mol/L sodium dihydrogen phosphate TS (pH 3.0) and acetonitrile (3:1), shake vigorously for 10 minutes, centrifuge, and filter the supernatant liquid through a membrane filter with a pore size not exceeding 0.45 μ m. Discard the first 5 mL of the filtrate, and use the subsequent filtrate as the sample solution.

Pipet 1 mL of the sample solution, add a mixture of 0.05 mol/L sodium dihydrogen phosphate TS (pH 3.0) and acetonitrile (3:1) to make exactly 100 mL, and use this solution as the standard solution. Perform the test with exactly 10 μ L each of the sample solution and standard solution as directed under Liquid Chromatography <2.01> according to the following conditions, and determine each peak area by the automatic integration method: the area of the peak, having a relative retention time of about 0.9 and about 3.2 to hydrochlorothiazide, obtained from the sample solution is not larger than the peak area of hydrochlorothiazide from the standard solution, and the area of the peak, other than hydrochlorothiazide and the peaks mentioned above, from the sample solution is not larger than 1/5 times the peak area of hydrochlorothiazide from the standard solution. Furthermore, the total area of the peaks other than hydrochlorothiazide from the sample solution is not larger than 2 times the peak area of hydrochlorothiazide from the standard solution. For the area of the peak, having a relative retention time of about 0.8 and about 0.9 to hydrochlorothiazide, multiply their correction factors, 1.4 and 0.5, respectively.

Operating conditions—

Detector, column, column temperature, mobile phase, and flow rate: Proceed as directed in the operating conditions in the Assay (2).

Time span of measurement: For 30 minutes after injection, beginning after the solvent peak.

System suitability—

Test for required detectability: To exactly 1 mL of the standard solution add a mixture of 0.05 mol/L sodium dihydrogen phosphate TS (pH 3.0) and acetonitrile (3:1) to make exactly 50 mL. Confirm that the peak area of hydrochlorothiazide obtained with 10 μ L of this solution is equivalent to 1.4% to 2.6% of that obtained with 10 μ L of the standard solution.

System performance: When the procedure is run with 10 μ L of the standard solution under the above operating conditions, the number of theoretical plates and the symmetry factor of the peak of hydrochlorothiazide are not less than 5000 and not more than 1.5, respectively.

System repeatability: When the test is repeated 6 times with 10 μ L of the standard solution under the above operating conditions, the relative standard deviation of the peak area of hydrochlorothiazide is not more than 2.0%.

Uniformity of dosage units <6.02> Perform the test according to the following methods: it meets the requirements of the Content uniformity test.

(1) Candesartan cilexetil—To 1 tablet of Candesartan Cilexetil and Hydrochlorothiazide Tablets add exactly $V/10$ mL of the internal standard solution, add a mixture of acetonitrile and 0.05 mol/L sodium dihydrogen phosphate TS (pH 3.0) (3:2) to make V mL so that each mL contains about 40 μ g of candesartan cilexetil ($C_{33}H_{34}N_6O_6$). Shake for 20 minutes to disintegrate the tablet, centrifuge, and use the supernatant liquid as the sample solution. Separately, weigh accurately about 50 mg of candesartan cilexetil for assay (separately determine the water <2.48> in the same manner as Candesartan Cilexetil), dissolve in acetonitrile to make exactly 50 mL, and use this solution as the candesartan cilexetil standard stock solution. Pipet 4 mL of the candesartan cilexetil standard stock solution, add exactly 10 mL of the internal standard solution, add a mixture of acetonitrile and 0.05 mol/L sodium dihydrogen phosphate TS (pH 3.0) (3:2) to make 100 mL, and use this solution as the standard solution. Perform the test with 10 μ L each of the sample solution and standard solution as directed under Liquid Chromatography

<2.01> according to the following conditions, and calculate the ratios, Q_T and Q_S , of the peak area of candesartan cilexetil to that of the internal standard.

$$\begin{aligned} \text{Amount (mg) of candesartan cilexetil (C}_{33}\text{H}_{34}\text{N}_6\text{O}_6) \\ = M_S \times Q_T/Q_S \times V \times 1/1250 \end{aligned}$$

M_S : Amount (mg) of candesartan cilexetil for assay taken, calculated on the anhydrous basis.

Internal standard solution—A solution of benzophenone in acetonitrile (1 in 10,000).

Operating conditions—

Detector: An ultraviolet absorption photometer (wavelength: 254 nm).

Column: A stainless steel column 4.6 mm in inside diameter and 15 cm in length, packed with octadecylsilanized silica gel for liquid chromatography (4 μ m in particle diameter).

Column temperature: A constant temperature of about 25°C.

Mobile phase: A mixture of acetonitrile and 0.05 mol/L sodium dihydrogen phosphate TS (pH 5.5) (11:9).

Flow rate: Adjust so that the retention time of candesartan cilexetil is about 7 minutes.

System suitability—

System performance: Mix 4 mL of the candesartan cilexetil standard stock solution and 10 mL of the hydrochlorothiazide standard stock solution obtained in (2), add 10 mL of the internal standard solution, and add a mixture of acetonitrile and 0.05 mol/L sodium dihydrogen phosphate TS (pH 3.0) (3:2) to make 100 mL. When the procedure is run with 10 μ L of this solution under the above operating conditions, hydrochlorothiazide, candesartan cilexetil and the internal standard are eluted in this order, and the resolution between the peaks of hydrochlorothiazide and candesartan cilexetil is not less than 7, and the resolution between the peaks of candesartan cilexetil and the internal standard is not less than 6.

System repeatability: When the test is repeated 6 times with 10 μ L of the standard solution under the above operating conditions, the relative standard deviation of the ratio of the peak area of candesartan cilexetil to that of the internal standard is not more than 1.0%.

(2) Hydrochlorothiazide—To 1 tablet of Candesartan Cilexetil and Hydrochlorothiazide Tablets add exactly $V/10$ mL of the internal standard solution, add a mixture of acetonitrile and 0.05 mol/L sodium dihydrogen phosphate TS (pH 3.0) (3:2) to make V mL so that each mL contains about 63 μ g of hydrochlorothiazide ($C_7H_8ClN_3O_4S_2$). Shake for 20 minutes, centrifuge, and use the supernatant liquid as the sample solution. Separately, weigh accurately about 31 mg of Hydrochlorothiazide RS (separately determine the loss on drying <2.41> under the same conditions as Hydrochlorothiazide), dissolve in acetonitrile to make exactly 50 mL, and use this solution as the hydrochlorothiazide standard stock solution. Pipet 10 mL of the hydrochlorothiazide standard stock solution, add exactly 10 mL of the internal standard solution, add a mixture of acetonitrile and 0.05 mol/L sodium dihydrogen phosphate TS (pH 3.0) (3:2) to make 100 mL, and use this solution as the standard solution. Perform the test with 10 μ L each of the sample solution and standard solution as directed under Liquid Chromatography <2.01> according to the following conditions, and calculate the ratios, Q_T and Q_S , of the peak area of hydrochlorothiazide to that of the internal standard.

$$\begin{aligned} \text{Amount (mg) of hydrochlorothiazide (C}_7\text{H}_8\text{ClN}_3\text{O}_4\text{S}_2) \\ = M_S \times Q_T/Q_S \times V \times 1/500 \end{aligned}$$

M_S : Amount (mg) of Hydrochlorothiazide RS taken, calculated on the dried basis.

Internal standard solution—A solution of benzophenone in acetonitrile (1 in 10,000).

Operating conditions—

Detector, column, and column temperature: Proceed as directed in the operating conditions in the Assay (2).

Mobile phase: A mixture of acetonitrile and 0.05 mol/L sodium dihydrogen phosphate TS (pH 5.5) (11:9).

Flow rate: Adjust so that the retention time of hydrochlorothiazide is about 3.5 minutes.

System suitability—

System performance: Mix 4 mL of the candesartan cilexetil standard stock solution obtained in (1) and 10 mL of the hydrochlorothiazide standard stock solution, add 10 mL of the internal standard solution, and add a mixture of acetonitrile and 0.05 mol/L sodium dihydrogen phosphate TS (pH 3.0) (3:2) to make 100 mL. When the procedure is run with 10 μ L of this solution under the above operating conditions, hydrochlorothiazide, candesartan cilexetil and the internal standard are eluted in this order, and the resolution between the peaks of hydrochlorothiazide and candesartan cilexetil is not less than 7, and the resolution between the peaks of candesartan cilexetil and the internal standard is not less than 6.

System repeatability: When the test is repeated 6 times with 10 μ L of the standard solution under the above operating conditions, the relative standard deviation of the ratio of the peak area of hydrochlorothiazide to that of the internal standard is not more than 1.0%.

Dissolution <6.10> (1) Candesartan cilexetil—When the test is performed at 50 revolutions per minute according to the Paddle method, using 900 mL of a solution, prepared by dissolving 1 g of polysorbate 80 in 2nd fluid for dissolution test to make 1000 mL, as the dissolution medium, the dissolution rate in 45 minutes of Candesartan Cilexetil and Hydrochlorothiazide Tablets is not less than 75%.

Start the test with 1 tablet of Candesartan Cilexetil and Hydrochlorothiazide Tablets, withdraw not less than 10 mL of the medium at the specified minute after starting the test, and filter through a membrane filter with a pore size not exceeding 0.45 μ m. Discard not less than 5 mL of the first filtrate, pipet V mL of the subsequent filtrate, add 0.05 mol/L sodium dihydrogen phosphate TS (pH 3.0) to make exactly V' mL so that each mL contains about 2.2 μ g of candesartan cilexetil ($C_{33}H_{34}N_6O_6$), and use this solution as the sample solution. Separately, weigh accurately about 25 mg of candesartan cilexetil for assay (separately determine the water <2.48> in the same manner as Candesartan Cilexetil), dissolve in acetonitrile to make exactly 100 mL, and use this solution as the candesartan cilexetil standard stock solution. Pipet 2 mL of the candesartan cilexetil standard stock solution, add dissolution medium to make exactly 100 mL. Pipet 10 mL of this solution, add 0.05 mol/L sodium dihydrogen phosphate TS (pH 3.0) to make exactly 20 mL, and use this solution as the standard solution. Perform the test with exactly 40 μ L each of the sample solution and standard solution as directed under Liquid Chromatography <2.01> according to the following conditions, and determine the peak areas, A_T and A_S , of candesartan cilexetil in each solution.

Dissolution rate (%) with respect to the labeled amount of candesartan cilexetil ($C_{33}H_{34}N_6O_6$)

$$= M_S \times A_T / A_S \times V' / V \times 1 / C \times 9$$

M_S : Amount (mg) of candesartan cilexetil for assay taken, calculated on the anhydrous basis

C : Labeled amount (mg) of candesartan cilexetil ($C_{33}H_{34}N_6O_6$) in 1 tablet

Operating conditions—

Proceed as directed in the operating conditions in the Uniformity of dosage units (1).

System suitability—

System performance: Mix 2 mL each of the candesartan cilexetil standard stock solution and the hydrochlorothiazide standard stock solution obtained in (2), and add the dissolution medium to make 100 mL. To 10 mL of this solution add 10 mL of 0.05 mol/L sodium dihydrogen phosphate TS (pH 3.0). When the procedure is run with 40 μ L of this solution under the above operating conditions, hydrochlorothiazide and candesartan cilexetil are eluted in this order with the resolution between these peaks being not less than 6.

System repeatability: When the test is repeated 6 times with 40 μ L of the standard solution under the above operating conditions, the relative standard deviation of the peak area of candesartan cilexetil is not more than 1.0%.

(2) Hydrochlorothiazide—When the test is performed at 50 revolutions per minute according to the Paddle method, using 900 mL of a solution, prepared by dissolving 1 g of polysorbate 80 in 2nd fluid for dissolution test to make 1000 mL, as the dissolution medium, the dissolution rate in 45 minutes of Candesartan Cilexetil and Hydrochlorothiazide Tablets is not less than 80%.

Start the test with 1 tablet of Candesartan Cilexetil and Hydrochlorothiazide Tablets, withdraw not less than 10 mL of the medium at the specified minute after starting the test, and filter through a membrane filter with a pore size not exceeding 0.45 μ m. Discard not less than 5 mL of the first filtrate, pipet V mL of the subsequent filtrate, add 0.05 mol/L sodium dihydrogen phosphate TS (pH 3.0) to make exactly V' mL so that each mL contains about 3.5 μ g of hydrochlorothiazide ($C_7H_8ClN_3O_4S_2$), and use this solution as the sample solution. Separately, weigh accurately about 38 mg of Hydrochlorothiazide RS (separately determine the loss on drying <2.41> under the same conditions as Hydrochlorothiazide), dissolve in acetonitrile to make exactly 100 mL, and use this solution as the hydrochlorothiazide standard stock solution. Pipet 2 mL of the hydrochlorothiazide standard stock solution, add dissolution medium to make exactly 100 mL. Pipet 10 mL of this solution, add 0.05 mol/L sodium dihydrogen phosphate TS (pH 3.0) to make exactly 20 mL, and use this solution as the standard solution. Perform the test with exactly 40 μ L each of the sample solution and standard solution as directed under Liquid Chromatography <2.01> according to the following conditions, and determine the peak areas, A_T and A_S , of hydrochlorothiazide in each solution.

Dissolution rate (%) with respect to the labeled amount of hydrochlorothiazide ($C_7H_8ClN_3O_4S_2$)

$$= M_S \times A_T / A_S \times V' / V \times 1 / C \times 9$$

M_S : Amount (mg) of Hydrochlorothiazide RS taken, calculated on the dried basis

C : Labeled amount (mg) of hydrochlorothiazide ($C_7H_8ClN_3O_4S_2$) in 1 tablet

Operating conditions—

Detector, column, and column temperature: Proceed as directed in the operating conditions in the Assay (2).

Mobile phase: A mixture of acetonitrile and 0.05 mol/L sodium dihydrogen phosphate TS (pH 5.5) (11:9).

Flow rate: Adjust so that the retention time of hydrochlorothiazide is about 3.5 minutes.

System suitability—

System performance: Mix 2 mL each of the candesartan cilexetil standard stock solution obtained in (1) and the hydrochlorothiazide standard stock solution, and add the dissolution medium to make 100 mL. To 10 mL of this solution add 10 mL of 0.05 mol/L sodium dihydrogen phosphate TS (pH 3.0). When the procedure is run with 40 μ L of this solution under the above operating conditions, hydrochlorothiazide and candesartan cilexetil are eluted in this order with the resolution between these peaks being not less than 6.

System repeatability: When the test is repeated 6 times with 40 μ L of the standard solution under the above operating conditions, the relative standard deviation of the peak area of hydrochlorothiazide is not more than 1.0%.

Assay (1) Candesartan cilexetil—Weigh accurately the mass of not less than 20 Candesartan Cilexetil and Hydrochlorothiazide Tablets, and powder. Weigh accurately a portion of the powder, equivalent to about 4 mg of candesartan cilexetil ($C_{33}H_{34}N_6O_6$), add exactly 10 mL of the internal standard solution, add a mixture of acetonitrile and water (3:2) to make 100 mL, and shake vigorously for 10 minutes. Allow to stand for 5 minutes, and filter the supernatant liquid through a membrane filter with a pore size not exceeding 0.45 μ m. Discard the first 5 mL of the filtrate, and use the subsequent filtrate as the sample solution. Separately, weigh accurately about 50 mg of candesartan cilexetil for assay (separately determine the water <2.48> in the same manner as Candesartan Cilexetil), dissolve in acetonitrile to make exactly 50 mL. Pipet 4 mL of this solution, add exactly 10 mL of the internal standard solution, add a mixture of acetonitrile and water (3:2) to make 100 mL, and use this solution as the standard solution. Perform the test with 10 μ L each of the sample solution and standard solution as directed under Liquid Chromatography <2.01> according to the following conditions, and calculate the ratios, Q_T and Q_S , of the peak area of candesartan cilexetil to that of the internal standard.

$$\begin{aligned} &\text{Amount (mg) of candesartan cilexetil (C}_{33}\text{H}_{34}\text{N}_6\text{O}_6) \\ &= M_S \times Q_T/Q_S \times 2/25 \end{aligned}$$

M_S : Amount (mg) of candesartan cilexetil for assay taken, calculated on the anhydrous basis

*Internal standard solution—*A solution of acenaphthene in acetonitrile (1 in 800).

Operating conditions—

Detector: An ultraviolet absorption photometer (wavelength: 254 nm).

Column: A stainless steel column 4 mm in inside diameter and 15 cm in length, packed with octadecylsilanized silica gel for liquid chromatography (4 μ m in particle diameter).

Column temperature: A constant temperature of about 25°C.

Mobile phase: A mixture of acetonitrile, water and acetic acid (100) (57:43:1).

Flow rate: Adjust so that the retention time of candesartan cilexetil is about 13 minutes.

System suitability—

System performance: When the procedure is run with 10 μ L of the standard solution under the above operating conditions, the internal standard and candesartan cilexetil are eluted in this order with the resolution between these peaks being not less than 5.

System repeatability: When the test is repeated 6 times with 10 μ L of the standard solution under the above operating conditions, the relative standard deviation of the ratio of the peak area of candesartan cilexetil to that of the internal standard is not more than 1.0%.

(2) Hydrochlorothiazide—Weigh accurately the mass of not less than 20 Candesartan Cilexetil and Hydrochlorothiazide Tablets, and powder. Weigh accurately a portion of the powder, equivalent to about 6.25 mg of hydrochlorothiazide ($C_7H_8ClN_3O_4S_2$), add exactly 10 mL of the internal standard solution, add a mixture of 0.05 mol/L sodium dihydrogen phosphate TS (pH 3.0) and acetonitrile (3:1) to make 100 mL, and shake vigorously for 10 minutes. Allow to stand for 5 minutes, and filter the supernatant liquid through a membrane filter with a pore size not exceeding 0.45 μ m. Discard the first 5 mL of the filtrate, and use the subsequent filtrate as the sample solution. Separately, weigh accurately about 31 mg of Hydrochlorothiazide RS (separately determine the loss on drying <2.41> under the same conditions as Hydrochlorothiazide), dissolve in acetonitrile to make exactly 50 mL. Pipet 10 mL of this solution, add exactly 10 mL of the internal standard solution, add a mixture of 0.05 mol/L sodium dihydrogen phosphate TS (pH 3.0) and acetonitrile (3:1) to make 100 mL, and use this solution as the standard solution. Perform the test with 10 μ L each of the sample solution and standard solution as directed under Liquid Chromatography <2.01> according to the following conditions, and calculate the ratios, Q_T and Q_S , of the peak area of hydrochlorothiazide to that of the internal standard.

$$\begin{aligned} &\text{Amount (mg) of hydrochlorothiazide (C}_7\text{H}_8\text{ClN}_3\text{O}_4\text{S}_2) \\ &= M_S \times Q_T/Q_S \times 1/5 \end{aligned}$$

M_S : Amount (mg) of Hydrochlorothiazide RS taken, calculated on the dried basis

*Internal standard solution—*A solution of *m*-hydroxyacetophenone in acetonitrile (1 in 6500).

Operating conditions—

Detector: An ultraviolet absorption photometer (wavelength: 254 nm).

Column: A stainless steel column 4.6 mm in inside diameter and 15 cm in length, packed with octadecylsilanized silica gel for liquid chromatography (4 μ m in particle diameter).

Column temperature: A constant temperature of about 25°C.

Mobile phase: A mixture of 0.05 mol/L sodium dihydrogen phosphate TS (pH 5.5) and acetonitrile (3:1).

Flow rate: Adjust so that the retention time of hydrochlorothiazide is about 6 minutes.

System suitability—

System performance: When the procedure is run with 10 μ L of the standard solution under the above operating conditions, hydrochlorothiazide and the internal standard are eluted in this order with the resolution between these peaks being not less than 5.

System repeatability: When the test is repeated 6 times with 10 μ L of the standard solution under the above operating conditions, the relative standard deviation of the ratio of the peak area of hydrochlorothiazide to that of the internal standard is not more than 1.0%.

Containers and storage Containers—Tight containers.

Capsules

カプセル

Capsules are made of Gelatin, and their shape is a pair of cylinders with one end closed which can be overlapped on each other.

Method of preparation Dissolve Gelatin in water by warming, add Glycerin or D-Sorbitol, Macrogol 4000, emulsifier, dispersing agent, preservatives, coloring substances and so forth, if necessary, to make a viscous liquid, and form into capsules while warm.

Capsules may be coated with a lubricant, if necessary.

Solubility and acidity or alkalinity Place, without overlapping of the parts, 1 piece (1 pair) of Capsules in a 100-mL conical flask, add 50 mL of water, and shake often, keeping the temperature at $37 \pm 2^\circ\text{C}$. Perform this test 5 times: they all dissolve within 10 minutes. All these solutions are odorless, and neutral or slightly acidic.

Loss on drying <2.41> 13 – 16% (1 g, 105°C , 2 hours).

Microbial limit <4.05> The acceptance criteria of TAMC and TYMC are 10^3 CFU/g and 10^2 CFU/g, respectively.

Containers and storage Containers—Well-closed containers.

Hypromellose Capsules

ヒプロメロースカプセル

Hypromellose Capsules are made of Hypromellose as the base material, and their shape is a pair of cylinders with one end closed which can be overlapped on each other.

The label states the use or nonuse of the gelling agent and its name.

Method of preparation Dissolve Hypromellose in water by warming, add, if necessary, Glycerin or D-Sorbitol, emulsifiers, dispersing agents, preservatives, coloring agents, gelling agents, and gelling aid, etc. to make a viscous liquid, and form into a certain shape while warming.

They may be coated with a lubricant as necessary.

Solubility and acidity or alkalinity Place one pair of Hypromellose Capsules without snapping in a 100-mL conical flask, add 50 mL of water, and shake occasionally at $37 \pm 2^\circ\text{C}$. When perform this test 5 times, either capsule dissolves within 15 minutes and their solutions are neutral or slightly acidic.

Loss on drying <2.41> 2 – 7% (1 g, 105°C , 2 hours).

Microbial limit <4.05> The acceptance criteria of TAMC and TYMC are 10^3 CFU/g and 10^2 CFU/g, respectively.

Containers and storage Containers—Well-closed containers.

Pullulan Capsules

プルランカプセル

Pullulan Capsules are made of Pullulan as the base material, and their shape is a pair of cylinders with one end closed which can be overlapped on each other.

The label states the use or nonuse of the gelling agent and its name.

Method of preparation Dissolve Pullulan in water by warming, add, if necessary, emulsifiers, dispersing agents, preservatives, coloring agents, gelling agents, and gelling aid, etc. to make a viscous liquid, and form into a certain shape while warming.

They may be coated with a lubricant as necessary.

Solubility and acidity or alkalinity Place one pair of Pullulan Capsules without snapping in a 100-mL conical flask, add 50 mL of water, and shake occasionally at $37 \pm 2^\circ\text{C}$. When perform this test 5 times, either capsule dissolves within 10 minutes and these solutions are neutral or slightly acidic.

Loss on drying <2.41> 10 – 14% (1 g, 105°C , 6 hours).

Microbial limit <4.05> The acceptance criteria of TAMC and TYMC are 10^3 CFU/g and 10^2 CFU/g, respectively.

Containers and storage Containers—Well-closed containers.

Captopril

カプトプリル

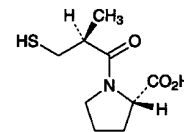

$\text{C}_9\text{H}_{15}\text{NO}_3\text{S}$: 217.29

(2S)-1-[(2S)-2-Methyl-3-sulfanylpropanoyl]pyrrolidine-2-carboxylic acid

[62571-86-2]

Captopril contains not less than 98.0% of captopril ($\text{C}_9\text{H}_{15}\text{NO}_3\text{S}$), calculated on the dried basis.

Description Captopril occurs as white, crystals or crystalline powder.

It is very soluble in methanol, freely soluble in ethanol (99.5), and soluble in water.

Identification Determine the infrared absorption spectrum of Captopril as directed in the potassium bromide disk method under Infrared Spectrophotometry <2.25>, and compare the spectrum with the Reference Spectrum: both spectra exhibit similar intensities of absorption at the same wave numbers.

Optical rotation <2.49> $[\alpha]_D^{25}$: $-125 - -134^\circ$ (after drying, 0.1 g, ethanol (99.5), 10 mL, 100 mm).

Melting point <2.60> 105 – 110°C

Purity (1) Heavy metals <1.07>—Proceed with 1.0 g of Captopril according to Method 2, and perform the test. Prepare the control solution with 2.0 mL of Standard Lead So-

lution (not more than 20 ppm).

(2) Arsenic <1.11>—Prepare the test solution with 1.0 g of Captopril according to Method 1, and perform the test (not more than 2 ppm).

(3) Related substances—Dissolve 0.20 g of Captopril in methanol to make exactly 10 mL, and use this solution as the sample solution. Separately, dissolve 15 mg of 1,1'-[3,3'-dithiobis(2-methyl-1-oxopropyl)]-L-dipropine in methanol to make exactly 250 mL, and use this solution as the standard solution. Perform the test with these solutions as directed under Thin-layer Chromatography <2.03>. Spot 10 μ L each of the sample solution and standard solution on a plate of silica gel for thin-layer chromatography. Develop with a mixture of toluene and acetic acid (100) (13:7) to a distance of about 15 cm, and air-dry the plate. Place the plate in a chamber filled with iodine vapor, and allow to stand for 30 minutes: the number of the spots other than the spot corresponding to that obtained from the standard solution and the principal spot from the sample solution is not more than two, and they are not more intense than the spot from the standard solution.

(4) 1,1'-[3,3'-Dithiobis(2-methyl-1-oxopropyl)]-L-dipropine—Dissolve 0.10 g of Captopril in methanol to make exactly 20 mL, and use this solution as the sample solution. Separately, dissolve 25 mg of 1,1'-[3,3'-dithiobis(2-methyl-1-oxopropyl)]-L-dipropine in methanol to make exactly 250 mL, and use this solution as the standard solution. Perform the test with exactly 20 μ L each of the sample solution and standard solution as directed under Liquid Chromatography <2.01> according to the following conditions, and determine the peak areas, A_T and A_S , of 1,1'-[3,3'-dithiobis(2-methyl-1-oxopropyl)]-L-dipropine in each solution: A_T is not larger than A_S .

Operating conditions—

Detector: An ultraviolet absorption photometer (wavelength: 220 nm).

Column: A stainless steel column 3.9 mm in inside diameter and 30 cm in length, packed with octadecylsilanized silica gel for liquid chromatography (10 μ m in particle diameter).

Column temperature: A constant temperature of about 25°C.

Mobile phase: A mixture of water, methanol and phosphoric acid (1000:1000:1).

Flow rate: Adjust so that the retention time of 1,1'-[3,3'-dithiobis(2-methyl-1-oxopropyl)]-L-dipropine is about 10 minutes.

System suitability—

System performance: Dissolve 25 mg each of Captopril and 1,1'-[3,3'-dithiobis(2-methyl-1-oxopropyl)]-L-dipropine in 200 mL of methanol. When the procedure is run with 20 μ L of this solution under the above operating conditions, captopril and 1,1'-[3,3'-dithiobis(2-methyl-1-oxopropyl)]-L-dipropine are eluted in this order with the resolution between these peaks being not less than 3.

System repeatability: When the test is repeated 5 times with 20 μ L of the standard solution under the above operating conditions, the relative standard deviation of the peak areas of 1,1'-[3,3'-dithiobis(2-methyl-1-oxopropyl)]-L-dipropine is not more than 2.0%.

Loss on drying <2.41> Not more than 1.0% (1 g, in vacuum, 80°C, 3 hours).

Residue on ignition <2.44> Not more than 0.2% (1 g).

Assay Weigh accurately about 0.3 g of Captopril, dissolve in 100 mL of water, add 20 mL of dilute sulfuric acid and 1 g of potassium iodide, and shake. Titrate <2.50> with 1/60

mol/L potassium iodate VS (indicator: 2 mL of starch TS). Perform a blank determination in the same manner, and make any necessary correction.

Each mL of 1/60 mol/L potassium iodate VS
= 21.73 mg of C₉H₁₅NO₃S

Containers and storage Containers—Tight containers.

Carbamazepine

カルバマゼピン

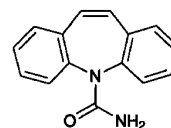

C₁₅H₁₂N₂O: 236.27

5*H*-Dibenz[*b,f*]azepine-5-carboxamide
[298-46-4]

Carbamazepine, when dried, contains not less than 97.0% and not more than 103.0% of carbamazepine (C₁₅H₁₂N₂O).

Description Carbamazepine occurs as a white to slightly yellow-white powder. It is odorless and tasteless at first, and leaves a slightly bitter aftertaste.

It is freely soluble in chloroform, sparingly soluble in ethanol (95) and in acetone, and very slightly soluble in water and in diethyl ether.

Identification (1) To 0.1 g of Carbamazepine add 2 mL of nitric acid, and heat on a water bath for 3 minutes: an orange-red color is produced.

(2) To 0.1 g of Carbamazepine add 2 mL of sulfuric acid, and heat on a water bath for 3 minutes: a yellow color is produced with a green fluorescence.

(3) Examine Carbamazepine under ultraviolet light: the solution shows an intense blue fluorescence.

(4) Determine the absorption spectrum of the solution obtained in the Assay as directed under Ultraviolet-visible Spectrophotometry <2.24>, and compare the spectrum with the Reference Spectrum: both spectra exhibit similar intensities of absorption at the same wavelengths.

Melting point <2.60> 189 – 193°C

Purity (1) Clarity and color of solution—Dissolve 1.0 g of Carbamazepine in 10 mL of chloroform: the solution is clear and colorless to pale yellow.

(2) Acidity—To 2.0 g of Carbamazepine add exactly 40 mL of water, stir well for 15 minutes, and filter through a glass filter (G3). To 10 mL of this filtrate add 1 drop of phenolphthalein TS and 0.50 mL of 0.01 mol/L sodium hydroxide VS: a red color is produced.

(3) Alkalinity—To 10 mL of the filtrate obtained in (2) add 1 drop of methyl red TS and 0.50 mL of 0.01 mol/L hydrochloric acid VS: a red color is produced.

(4) Chloride <1.03>—Dissolve 0.25 g of Carbamazepine in 30 mL of acetone, add 6 mL of dilute nitric acid and water to make 50 mL, and perform the test using this solution as the test solution. Prepare the control solution as follows: to 0.20 mL of 0.01 mol/L hydrochloric acid VS add 30 mL of acetone, 6 mL of dilute nitric acid and water to make 50 mL (not more than 0.028%).

(5) Heavy metals <1.07>—Proceed with 2.0 g of Carbamazepine according to Method 2, and perform the test.

Prepare the control solution with 2.0 mL of Standard Lead Solution (not more than 10 ppm).

(6) Related substances—Dissolve 0.25 g of Carbamazepine in 10 mL of chloroform, and use this solution as the sample solution. Separately, dissolve 5.0 mg of iminodibenzyl in chloroform to make exactly 100 mL, and use this solution as the standard solution. Perform the test with these solutions as directed under Thin-layer Chromatography <2.03>. Spot 10 μ L each of the sample solution and standard solution on a plate of silica gel for thin-layer chromatography. Develop the plate with a mixture of toluene and methanol (19:1) to a distance of about 10 cm, and air-dry the plate. Spray evenly potassium dichromate-sulfuric acid TS on the plate: the spots other than the principal spot obtained from the sample solution is not more intense than the spot from the standard solution.

Loss on drying <2.41> Not more than 0.5% (1 g, 105°C, 2 hours).

Residue on ignition <2.44> Not more than 0.1% (1 g).

Assay Dissolve about 50 mg of Carbamazepine, previously dried and accurately weighed, in ethanol (95) to make exactly 250 mL. Pipet 5 mL of this solution and add ethanol (95) to make exactly 100 mL. Perform the test as directed under Ultraviolet-visible Spectrophotometry <2.24>, and determine the absorbance *A* of this solution at the wavelength of maximum absorption at about 285 nm.

$$\begin{aligned} \text{Amount (mg) of carbamazepine (C}_{15}\text{H}_{12}\text{N}_2\text{O)} \\ = A/490 \times 50,000 \end{aligned}$$

Containers and storage Containers—Tight containers.

Carbazochrome Sodium Sulfonate Hydrate

カルバゾクロムスルホン酸ナトリウム水和物

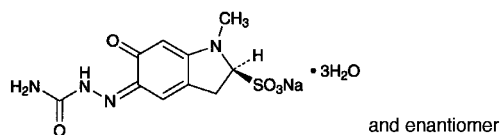

$\text{C}_{10}\text{H}_{11}\text{N}_4\text{NaO}_5\text{S}\cdot 3\text{H}_2\text{O}$: 376.32

Monosodium (2*RS*)-1-methyl-6-oxo-5-semicarbazono-2,3,5,6-tetrahydroindole-2-sulfonate trihydrate [51460-26-5, anhydride]

Carbazochrome Sodium Sulfonate Hydrate contains not less than 98.0% and not more than 102.0% of carbazochrome sodium sulfonate ($\text{C}_{10}\text{H}_{11}\text{N}_4\text{NaO}_5\text{S}$: 322.27), calculated on the anhydrous basis.

Description Carbazochrome Sodium Sulfonate Hydrate occurs as orange-yellow, crystals or crystalline powder.

It is sparingly soluble in water, very slightly soluble in methanol and in ethanol (95), and practically insoluble in diethyl ether.

A solution of Carbazochrome Sodium Sulfonate Hydrate (1 in 100) shows no optical rotation.

Melting point: about 210°C (with decomposition).

Identification (1) Determine the absorption spectrum of a solution of Carbazochrome Sodium Sulfonate Hydrate (1 in 100,000) as directed under Ultraviolet-visible Spectrophotometry <2.24>, and compare the spectrum with the Refer-

ence Spectrum: both spectra exhibit similar intensities of absorption at the same wavelengths.

(2) Determine the infrared absorption spectrum of Carbazochrome Sodium Sulfonate Hydrate as directed in the potassium bromide disk method under Infrared Spectrophotometry <2.25>, and compare the spectrum with the Reference Spectrum: both spectra exhibit similar intensities of absorption at the same wave numbers.

(3) A solution of Carbazochrome Sodium Sulfonate Hydrate (1 in 100) responds to Qualitative Tests <1.09> (1) for sodium salt.

pH <2.54> Dissolve 0.8 g of Carbazochrome Sodium Sulfonate Hydrate in 50 mL of water by warming, and cool: the pH of this solution is between 5.0 and 6.0.

Purity (1) Clarity and color of solution—Dissolve 1.0 g of Carbazochrome Sodium Sulfonate Hydrate in 50 mL of water by warming, and allow to cool: the solution is clear. Perform the test with this solution as directed under Ultraviolet-visible Spectrophotometry <2.24>: the absorbance at 590 nm is not more than 0.070.

(2) Heavy metals <1.07>—Proceed with 1.0 g of Carbazochrome Sodium Sulfonate Hydrate according to Method 2, and perform the test. Prepare the control solution with 2.0 mL of Standard Lead Solution (not more than 20 ppm).

(3) Related substances—Dissolve 50 mg of Carbazochrome Sodium Sulfonate Hydrate in 100 mL of water, and use this solution as the sample solution. Pipet 2 mL of the sample solution, add water to make exactly 200 mL, and use this solution as the standard solution. Perform the test with exactly 10 μ L each of the sample solution and standard solution as directed under Liquid Chromatography <2.01> according to the following conditions. Determine each peak area of these solutions by the automatic integration method: the total area of the peaks other than carbazochrome sulfonate obtained from the sample solution is not larger than the peak area of carbazochrome sulfonate from the standard solution.

Operating conditions—

Detector: An ultraviolet absorption photometer (wavelength: 360 nm).

Column: A stainless steel column 4.6 mm in inside diameter and 25 cm in length, packed with octadecylsilanized silica gel for liquid chromatography (7 μ m in particle diameter).

Column temperature: A constant temperature of about 40°C.

Mobile phase: Dissolve 1.2 g of ammonium dihydrogen phosphate in 1000 mL of water, and filter through a membrane filter (0.4 μ m in pore size) if necessary. To 925 mL of this solution add 75 mL of ethanol (95), shake, and adjust the pH to 3 with phosphoric acid.

Flow rate: Adjust so that the retention time of carbazochrome sulfonate is about 7 minutes.

Time span of measurement: About 3 times as long as the retention time of carbazochrome sulfonate, beginning after the solvent peak.

System suitability—

Test for required detectability: To exactly 2 mL of the standard solution add the mobile phase to make exactly 20 mL. Confirm that the peak area of carbazochrome sulfonate obtained with 10 μ L of this solution is equivalent to 7 to 13% of that with 10 μ L of the standard solution.

System performance: Dissolve 10 mg each of Carbazochrome Sodium Sulfonate Hydrate and carbazochrome in 100 mL of water by warming. When the procedure is run with 10 μ L of this solution under the above operating condi-

tions, carbazochrome sulfonate and carbazochrome are eluted in this order with the resolution between these peaks being not less than 3.

System repeatability: When the test is repeated 6 times with 10 μL of the standard solution under the above operating conditions, the relative standard deviation of the peak area of carbazochrome sulfonate is not more than 2.0%.

Water <2.48> 13.0 – 16.0% (0.3 g, volumetric titration, direct titration).

Assay Weigh accurately about 0.25 g of Carbazochrome Sodium Sulfonate Hydrate, dissolve in 50 mL of water, apply to a chromatographic column, 10 mm in diameter, previously prepared with 20 mL of strongly acidic ion exchange resin for column chromatography (type H), and allow to flow at a rate of 4 mL per minute. Wash the column with 150 mL of water, combine the washing and the former effluent solution, and titrate <2.50> with 0.05 mol/L sodium hydroxide VS (potentiometric titration). Perform a blank determination in the same manner, and make any necessary correction.

Each mL of 0.05 mol/L sodium hydroxide VS
= 16.11 mg of $\text{C}_{10}\text{H}_{11}\text{N}_4\text{NaO}_5\text{S}$

Containers and storage Containers—Well-closed containers.

Carbidopa Hydrate

カルビドパ水和物

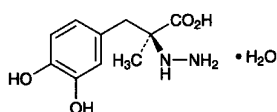

$\text{C}_{10}\text{H}_{14}\text{N}_2\text{O}_4 \cdot \text{H}_2\text{O}$: 244.24
(2*S*)-2-(3,4-Dihydroxybenzyl)-2-hydrazinopropanoic acid monohydrate
[38821-49-7]

Carbidopa Hydrate contains not less than 98.0% of carbidopa hydrate ($\text{C}_{10}\text{H}_{14}\text{N}_2\text{O}_4 \cdot \text{H}_2\text{O}$).

Description Carbidopa Hydrate occurs as a white to yellowish white powder.

It is sparingly soluble in methanol, slightly soluble in water, very slightly soluble in ethanol (95), and practically insoluble in diethyl ether.

Melting point: about 197°C (with decomposition).

Identification (1) Dissolve 0.01 g of Carbidopa Hydrate in 250 mL of a solution of hydrochloric acid in methanol (9 in 1000). Determine the absorption spectrum of this solution as directed under Ultraviolet-visible Spectrophotometry <2.24>, and compare the spectrum with the Reference Spectrum or the spectrum of a solution of Carbidopa RS prepared in the same manner as the sample solution: both spectra exhibit similar intensities of absorption at the same wavelengths.

(2) Determine the infrared absorption spectrum of Carbidopa Hydrate as directed in the potassium bromide disk method under Infrared Spectrophotometry <2.25>, and compare the spectrum with the Reference Spectrum or the spectrum of Carbidopa RS: both spectra exhibit similar intensities of absorption at the same wave numbers.

Optical rotation <2.49> $[\alpha]_{\text{D}}^{20}$: $-21.0 - -23.5^\circ$ (1 g, alumi-

num (III) chloride TS, 100 mL, 100 mm).

Purity (1) Heavy metals <1.07>—Proceed with 2.0 g of Carbidopa Hydrate according to Method 2, and perform the test. Prepare the control solution with 2.0 mL of Standard Lead Solution (not more than 10 ppm).

(2) Related substances—Dissolve 50 mg of Carbidopa Hydrate in 70 mL of the mobile phase, by warming and using ultrasonication, if necessary. After cooling, add the mobile phase to make 100 mL, and use this solution as the sample solution. Pipet 1 mL of the sample solution, add the mobile phase to make exactly 100 mL, and use this solution as the standard solution. Perform the test with exactly 20 μL each of the sample solution and standard solution as directed under Liquid Chromatography <2.01> according to the following conditions. Determine each peak area from both solutions by the automatic integration method: the total area of the peaks other than carbidopa obtained from the sample solution is not larger than the peak area of carbidopa from the standard solution.

Operating conditions—

Detector, column, column temperature, mobile phase, and flow rate: Proceed as directed in the operating conditions in the Assay.

Time span of measurement: About 3 times as long as the retention time of carbidopa.

System suitability—

System performance, and system repeatability: Proceed as directed in the system suitability in the Assay.

Test for required detectability: To exactly 2 mL of the standard solution add the mobile phase to make exactly 20 mL. Confirm that the peak area of carbidopa obtained with 20 μL of this solution is equivalent to 7 to 13% of that with 20 μL of the standard solution.

Loss on drying <2.41> 6.9 – 7.9% (1 g, in vacuum not exceeding 0.67 kPa, 100°C, 6 hours).

Residue on ignition <2.44> Not more than 0.1% (1 g).

Assay Weigh accurately about 50 mg each of Carbidopa Hydrate and Carbidopa RS (separately determine the loss on drying <2.41> under the same conditions as Carbidopa Hydrate), and dissolve each in 70 mL of the mobile phase, by warming and using ultrasonication if necessary. After cooling, add the mobile phase to make exactly 100 mL, and use these solutions as the sample solution and the standard solution, respectively. Perform the test with exactly 20 μL each of the sample solution and standard solution as directed under Liquid Chromatography <2.01> according to the following conditions, and determine the peak areas, A_T and A_S , of carbidopa in each solution.

Amount (mg) of carbidopa hydrate ($\text{C}_{10}\text{H}_{14}\text{N}_2\text{O}_4 \cdot \text{H}_2\text{O}$)
= $M_S \times A_T / A_S \times 1.080$

M_S : Amount (mg) of Carbidopa RS taken, calculated on the dried basis

Operating conditions—

Detector: An ultraviolet absorption photometer (wavelength: 280 nm).

Column: A stainless steel column 4 mm in inside diameter and 25 cm in length, packed with octadecylsilanized silica gel for liquid chromatography (7 μm in particle diameter).

Column temperature: A constant temperature of about 25°C.

Mobile phase: To 950 mL of 0.05 mol/L sodium dihydrogen phosphate TS add 50 mL of ethanol (95), and adjust the pH to 2.7 with phosphoric acid.

Flow rate: Adjust so that the retention time of carbidopa is about 6 minutes.

System suitability—

System performance: Dissolve 50 mg each of Carbidopa Hydrate and methyldopa in 100 mL of the mobile phase. When the procedure is run with 20 μ L of this solution under the above operating conditions, methyldopa and carbidopa are eluted in this order with the resolution between these peaks being not less than 0.9.

System repeatability: When the test is repeated 6 times with 20 μ L of the standard solution under the above operating conditions, the relative standard deviation of the peak area of carbidopa is not more than 1.0%.

Containers and storage Containers—Tight containers.

Storage—Light-resistant.

L-Carbocysteine

L-カルボシステイン

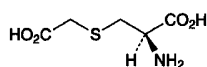

$C_5H_9NO_4S$: 179.19

(2*R*)-2-Amino-3-carboxymethylsulfanylpropanoic acid
[638-23-3]

L-Carbocysteine, when dried, contains not less than 98.5% of L-carbocysteine ($C_5H_9NO_4S$).

Description L-Carbocysteine occurs as a white crystalline powder. It is odorless, and has a slightly acid taste.

It is very slightly soluble in water, and practically insoluble in ethanol (95).

It dissolves in dilute hydrochloric acid or in sodium hydroxide TS.

Melting point: about 186°C (with decomposition).

Identification (1) To 0.2 g of L-Carbocysteine add 1 mL of lead acetate TS and 3 mL of water, shake, add 0.2 g of sodium hydroxide, and heat over a flame for 1 minute: a dark brown to black precipitate is formed.

(2) Determine the infrared absorption spectrum of L-Carbocysteine as directed in the potassium bromide disk method under Infrared Spectrophotometry <2.25>, and compare the spectrum with the Reference Spectrum: both spectra exhibit similar intensities of absorption at the same wave numbers.

Optical rotation <2.49> $[\alpha]_D^{20}$: $-33.5 - -36.5^\circ$ Weigh accurately about 5 g of L-Carbocysteine, previously dried, dissolve in 20 mL of water and a suitable amount of a solution of sodium hydroxide (13 in 100), and adjust the pH with 1 mol/L hydrochloric acid TS or 0.1 mol/L hydrochloric acid TS to 6.0, and add water to make exactly 50 mL. Determine the optical rotation of this solution in a 100-mm cell.

Purity (1) Clarity and color of solution—Dissolve 1.0 g of L-Carbocysteine in 10 mL of sodium hydroxide TS: the solution is clear and colorless.

(2) Chloride <1.03>—Dissolve 0.20 g of L-Carbocysteine in 10 mL of water and 20 mL of nitric acid, and add water to make 50 mL. Perform the test using this solution as the test solution. Prepare the control solution as follows. To 0.40 mL of 0.01 mol/L hydrochloric acid VS add 20 mL of nitric acid and water to make 50 mL (not more than 0.071%).

(3) Ammonium <1.02>—Perform the test with 0.25 g of

L-Carbocysteine using the distillation under reduced pressure. Prepare the control solution with 5.0 mL of Standard Ammonium Solution (not more than 0.02%).

(4) Heavy metals <1.07>—Proceed with 1.0 g of L-Carbocysteine according to Method 2, and perform the test. Prepare the control solution with 2.0 mL of Standard Lead Solution (not more than 20 ppm).

(5) Arsenic <1.11>—Prepare the test solution with 1.0 g of L-Carbocysteine according to Method 3, and perform the test (not more than 2 ppm).

(6) Related substances—Dissolve 0.30 g of L-Carbocysteine in 10 mL of 0.2 mol/L sodium hydroxide TS, and use this solution as the sample solution. Pipet 2 mL of the sample solution, and add 0.2 mol/L sodium hydroxide TS to make exactly 100 mL. Pipet 1 mL of this solution, and add 0.2 mol/L sodium hydroxide TS to make exactly 10 mL, and use this solution as the standard solution. Perform the test with these solutions as directed under Thin-layer Chromatography <2.03>. Spot 5 μ L each of the sample solution and standard solution, in 15 mm length along the starting line on a plate of silica gel for thin-layer chromatography. Develop the plate with a mixture of 1-butanol, water and acetic acid (100) (3:1:1) to a distance of about 10 cm, and dry the plate at 80°C for 30 minutes. Spray evenly a solution of ninhydrin in acetone (1 in 50) on the plate, and heat the plate at 80°C for 5 minutes: the spots other than the principal spot obtained from the sample solution are not more intense than the spot from the standard solution.

Loss on drying <2.41> Not more than 0.30% (1 g, 105°C, 2 hours).

Residue on ignition <2.44> Not more than 0.1% (1 g).

Assay Weigh accurately about 0.25 g of L-Carbocysteine, previously dried, dissolve in exactly 20 mL of 0.1 mol/L perchloric acid VS and 50 mL of acetic acid (100), and titrate <2.50> the excess perchloric acid with 0.1 mol/L sodium acetate VS (potentiometric titration). Perform a blank determination in the same manner.

Each mL of 0.1 mol/L perchloric acid VS
= 17.92 mg of $C_5H_9NO_4S$

Containers and storage Containers—Tight containers.

L-Carbocysteine Tablets

L-カルボシステイン錠

L-Carbocysteine Tablets contain not less than 95.0% and not more than 105.0% of the labeled amount of L-carbocysteine ($C_5H_9NO_4S$: 179.19).

Method of Preparation Prepare as directed under Tablets, with L-Carbocysteine.

Identification Powder L-Carbocysteine Tablets. To a portion of the powder, equivalent to 0.18 g of L-Carbocysteine, add 50 mL of water, stir for 10 minutes, and filter. To 5 mL of the filtrate add 1 mL of ninhydrin TS, and heat in a water bath for 3 minutes: a purple color develops.

Uniformity of dosage units <6.02> It meets the requirement of the Mass variation test.

Dissolution <6.10> When the test is performed at 75 revolutions per minute according to the Paddle method, using 900 mL of water as the dissolution medium, the dissolution rates in 15 minutes of 250-mg tablet and in 30 minutes of 500-mg

tablet are not less than 80% and not less than 85%, respectively.

Start the test with 1 tablet of L-Carbocisteine Tablets, withdraw not less than 20 mL of the medium at the specified minute after starting the test, and filter through a membrane filter with a pore size not exceeding 0.45 μm . Discard not less than 10 mL of the first filtrate, pipet V mL of the subsequent filtrate, add the mobile phase to make exactly V' mL so that each mL contains about 0.14 mg of L-carbocisteine ($\text{C}_5\text{H}_9\text{NO}_4\text{S}$), and use this solution as the sample solution. Separately, weigh accurately about 28 mg of L-carbocisteine for assay, previously dried at 105°C for 2 hours, and dissolve in the mobile phase to make exactly 200 mL, and use this solution as the standard solution. Perform the test with exactly 20 μL each of the sample solution and standard solution as directed under Liquid Chromatography <2.01> according to the following condition, and determine the peak areas, A_T and A_S , of L-carbocisteine in each solution.

Dissolution rate (%) with respect to the labeled amount of L-carbocisteine ($\text{C}_5\text{H}_9\text{NO}_4\text{S}$)

$$= M_S \times A_T/A_S \times V'/V \times 1/C \times 450$$

M_S : Amount (mg) of L-carbocisteine for assay taken

C : Labeled amount (mg) of L-carbocisteine ($\text{C}_5\text{H}_9\text{NO}_4\text{S}$) in 1 tablet

Operating conditions—

Proceed as directed in the operating conditions in the Assay.

System suitability—

System performance: When the procedure is run with 20 μL of the standard solution under the above operating conditions, the number of theoretical plates and the symmetry factor of the peak of L-carbocisteine are not less than 1500 and not more than 2.0, respectively.

System repeatability: When the test is repeated 6 times with 20 μL of the standard solution under the above operating conditions, the relative standard deviation of the peak area of L-carbocisteine is not more than 1.0%.

Assay To 10 L-Carbocisteine Tablets add 220 mL of 0.5 mol/L hydrochloric acid TS, stir for 30 minutes, add 0.5 mol/L hydrochloric acid TS to make exactly 250 mL, and stir additionally for 30 minutes. Filter this solution, discard the first 20 mL of the filtrate, pipet 2 mL of the subsequent filtrate, add $(V-50)/25$ mL of 0.5 mol/L hydrochloric acid TS, then add exactly $V/25$ mL of the internal standard solution, add water to make V mL so that each mL contains about 0.4 mg of L-carbocisteine ($\text{C}_5\text{H}_9\text{NO}_4\text{S}$), and use this solution as the sample solution. Separately, weigh accurately about 20 mg of L-carbocisteine for assay, previously dried at 105°C for 2 hours, add 2 mL of 0.5 mol/L hydrochloric acid TS, and exactly 2 mL of the internal standard solution. Then add water to dissolve to make 50 mL, and use this solution as the standard solution. Perform the test with 5 μL each of the sample solution and standard solution as directed under Liquid Chromatography <2.01> according to the following conditions, and calculate the ratios, Q_T and Q_S , of the peak area of L-carbocisteine to that of the internal standard.

Amount (mg) of L-carbocisteine ($\text{C}_5\text{H}_9\text{NO}_4\text{S}$) in 1 tablet
 $= M_S \times Q_T/Q_S \times V/4$

M_S : Amount of L-carbocisteine for assay taken

Internal standard solution—A solution of nicotinic acid (9 in 10,000).

Operating conditions—

Detector: An ultraviolet absorption photometer (wave-

length: 240 nm).

Column: A stainless steel column 4.6 mm in inside diameter and 15 cm in length, packed with octadecylsilanized silica gel for liquid chromatography (5 μm in particle diameter).

Column temperature: A constant temperature of about 20°C.

Mobile phase: Diluted trifluoroacetic acid (1 in 1000).

Flow rate: Adjust so that the retention time of L-carbocisteine is about 2 minutes.

System suitability—

System performance: When the procedure is run with 5 μL of the standard solution under the above operating conditions, L-carbocisteine and the internal standard are eluted in this order with the resolution between these peaks being not less than 4.

System repeatability: When the test is repeated 6 times with 5 μL of the standard solution under the above operating conditions, the relative standard deviation of the ratio of the peak area of L-carbocisteine to that of the internal standard is not more than 1.0%.

Containers and storage Containers—Tight containers.

Carbon Dioxide

二酸化炭素

CO₂: 44.01

[124-38-9]

Carbon Dioxide contains not less than 99.5 vol% of carbon dioxide (CO₂).

Description Carbon Dioxide is a colorless gas at room temperature and under atmospheric pressure. It is odorless.

A 1 mL volume of Carbon Dioxide dissolves in 1 mL of water, and the solution is slightly acid.

1000 mL of Carbon Dioxide at 0°C and under a pressure of 101.3 kPa weighs 1.978 g.

Identification (1) Pass 100 mL of Carbon Dioxide through a carbon dioxide measuring detector tube: the detector tube is changed to a stipulated color tone by each detector tube, provided that the detector tube with a upper limit of measurement of not less than 10% is used.

(2) Pass Carbon Dioxide into calcium hydroxide TS: a white precipitate is produced. Collect the precipitate, and add acetic acid (31): it dissolves with effervescence.

Purity (1) Acidity—Place 50 mL of freshly boiled and cooled water in a Nessler tube, and pass 1000 mL of Carbon Dioxide into it for 15 minutes through an introducing tube about 1 mm in diameter extending to 2 mm from the bottom of the Nessler tube, then add 0.10 mL of methyl orange TS: the solution is not more colored than the following control solution.

Control solution: To 50 mL of freshly boiled and cooled water in a Nessler tube add 0.10 mL of methyl orange TS and 1.0 mL of 0.01 mol/L hydrochloric acid VS.

(2) Hydrogen phosphide, hydrogen sulfide or reducing organic substances—Place 25 mL of silver nitrate-ammonia TS and 3 mL of ammonia TS in each of two Nessler tubes A and B, and designate the solution in each tube as solution A and solution B, respectively. Pass 1000 mL of Carbon Dioxide into solution A in the same manner as directed in (1): the turbidity and color of this solution are the same as that of solution B.

(3) Carbon monoxide—Pass a specified amount of Carbon Dioxide through a carbon monoxide measuring detector tube: the concentration of carbon monoxide is less than 15 ppm, provided that the passing amount (mL) of Carbon Dioxide is stipulated according to each detector tube.

Assay Place 125 mL of a solution of potassium hydroxide (1 in 2) in a gas pipet of suitable capacity. Measure exactly about 100 mL of Carbon Dioxide in a 100-mL gas buret filled with water. Force the entire volume of gas into the gas pipet, and shake for 5 minutes. Draw some of the unabsorbed gas into the gas buret, measure the volume, force the residual back upon the surface of the liquid in the gas pipet, and repeat this procedure until a constant volume of the residual reading is obtained. Determine the volume V (mL) of the residual gas. Calculate the volume of the sample and V on the basis of the gas volume at 20°C and at 101.3 kPa.

$$\begin{aligned} \text{Volume (mL) of carbon dioxide (CO}_2\text{)} \\ = \text{volume (mL) of the sample} - V \text{ (mL)} \end{aligned}$$

Containers and storage Containers—Cylinders.

Storage—Not exceeding 40°C.

Carboplatin

カルボプラチン

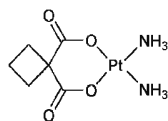

$C_6H_{12}N_2O_4Pt$: 371.25

(*SP-4-2*)-Diammine[cyclobutan-1,1-dicarboxylato(2-)-*O,O'*]platinum
[41575-94-4]

Carboplatin contains not less than 98.5% and not more than 101.0% of carboplatin ($C_6H_{12}N_2O_4Pt$), calculated on the dried basis.

Description Carboplatin occurs as white, crystals or crystalline powder.

It is sparingly soluble in water, and very slightly soluble in ethanol (99.5).

Melting point: about 200°C (with decomposition).

Identification (1) To 2 mL of a solution of Carboplatin (1 in 100) add 2 to 3 drops of diluted tin (II) chloride TS (1 in 15), and allow to stand for 30 minutes: a yellowish brown precipitate is formed.

(2) Determine the infrared absorption spectrum of Carboplatin as directed in the potassium bromide disk method under Infrared Spectrophotometry <2.25>, and compare the spectrum with the Reference Spectrum or the spectrum of Carboplatin RS: both spectra exhibit similar intensities of absorption at the same wave numbers.

pH <2.54> Dissolve 0.10 g of Carboplatin in 10 mL of water: the pH of this solution is 5.0 to 7.0.

Purity (1) 1,1-Cyclobutanedicarboxylic acid—Weigh accurately about 40 mg of Carboplatin, dissolve in the mobile phase to make exactly 20 mL, and use this solution as the sample solution. Separately, weigh accurately about 25 mg of 1,1-cyclobutanedicarboxylic acid, and dissolve in the mobile phase to make exactly 100 mL. Pipet 4 mL of this solution, add the mobile phase to make exactly 50 mL, and use this solution as the standard solution. Perform the test with exactly 25 μ L each of the sample solution and standard

solution as directed under Liquid Chromatography <2.01> according to the following conditions. Determine the peak areas, A_T and A_S , of 1,1-cyclobutanedicarboxylic acid in each solution, and calculate the amount of 1,1-cyclobutanedicarboxylic acid by the following formula: it is not more than 0.2%.

$$\begin{aligned} \text{Amount (\%)} \text{ of 1,1-cyclobutanedicarboxylic acid} \\ = M_S/M_T \times A_T/A_S \times 8/5 \end{aligned}$$

M_S : Amount (mg) of 1,1-cyclobutanedicarboxylic acid taken

M_T : Amount (mg) of Carboplatin taken

Operating conditions—

Detector: An ultraviolet absorption photometer (wavelength: 220 nm).

Column: A stainless steel column 4.0 mm in inside diameter and 30 cm in length, packed with octadecylsilanized silica gel for liquid chromatography (7 μ m in particle diameter).

Column temperature: A constant temperature of about 35°C.

Mobile phase: Dissolve 8.5 g of tetrabutylammonium hydrogensulfate in 80 mL of water, add 3.4 mL of phosphoric acid, and adjust to pH 7.5 with a solution of sodium hydroxide (43 in 100). To 10 mL of this solution add 430 mL of water and 60 mL of acetonitrile.

Flow rate: Adjust so that the retention time of 1,1-cyclobutanedicarboxylic acid is about 5 minutes.

System suitability—

Test for required detectability: To exactly 2 mL of the standard solution add the mobile phase to make exactly 10 mL. Confirm that the peak area of 1,1-cyclobutanedicarboxylic acid obtained with 25 μ L of this solution is equivalent to 14 to 26% of that with 25 μ L of the standard solution.

System performance: Dissolve 25 mg each of 1,1-cyclobutanedicarboxylic acid and cyclobutanedicarboxylic acid in 100 mL of water. To 10 mL of this solution add the mobile phase to make 25 mL. When the procedure is run with 25 μ L of this solution under the above operating conditions, cyclobutanedicarboxylic acid and 1,1-cyclobutanedicarboxylic acid are eluted in this order with the resolution between these peaks being not less than 3.

System repeatability: When the test is repeated 6 times with 25 μ L of the standard solution under the above operating conditions, the relative standard deviation of the peak area of 1,1-cyclobutanedicarboxylic acid is not more than 2.0%.

(2) Related substances—Dissolve 25 mg of Carboplatin in 25 mL of water, and use this solution as the sample solution. Perform the test with 10 μ L of the sample solution as directed under Liquid Chromatography <2.01> according to the following conditions, and determine each peak area by the automatic integration method. Calculate the amount of the peaks by the area percentage method: the amount of the peak, having the relative retention time of about 0.8 to carboplatin, is not more than 0.25%, the amount of the peak other than carboplatin and the peak mentioned above is not more than 0.1%, and the total amount of the peaks other than carboplatin is not more than 0.5%.

Operating conditions—

Detector, column, column temperature, mobile phases A and B, and flow rate: Proceed as directed in the operating conditions in the Assay.

Flowing of mobile phase: Control the gradient by mixing the mobile phases A and B as directed in the following table.

Time after injection of sample (min)	Mobile phase A (vol%)	Mobile phase B (vol%)
0 - 15	100	0
15 - 35	100 → 0	0 → 100
35 - 50	0	100

Time span of measurement: About 2.5 times as long as the retention time of carboplatin, beginning after the solvent peak.

System suitability—

System performance: Proceed as directed in the system suitability in the Assay.

Test for required detectability: To 1 mL of the sample solution add water to make 100 mL, and use this solution as the solution for system suitability test. Pipet 1 mL of the solution for system suitability test, and add water to make exactly 20 mL. Confirm that the peak area of carboplatin obtained with 10 μ L of this solution is equivalent to 3.5 to 6.5% of that with 10 μ L of the solution for system suitability test.

System repeatability: When the test is repeated 6 times with 10 μ L of the solution for system suitability test under the above operating conditions, the relative standard deviation of the peak area of carboplatin is not more than 2.0%.

Loss on drying <2.41> Not more than 0.1% (0.5 g, 105°C, 4 hours).

Assay Weigh accurately about 25 mg each of Carboplatin and Carboplatin RS (separately determine the loss on drying <2.41> under the same conditions as Carboplatin), dissolve separately in water to make exactly 25 mL, and use these solutions as the sample solution and the standard solution, respectively. Perform the test with exactly 10 μ L each of the sample solution and standard solution as directed under Liquid Chromatography <2.01> according to the following conditions, and determine the peak areas, A_T and A_S , of carboplatin in each solution.

$$\begin{aligned} &\text{Amount (mg) of carboplatin (C}_6\text{H}_{12}\text{N}_2\text{O}_4\text{Pt)} \\ &= M_S \times A_T/A_S \end{aligned}$$

M_S : Amount (mg) of Carboplatin RS taken, calculated on the dried basis

Operating conditions—

Detector: An ultraviolet absorption photometer (wavelength: 220 nm).

Column: A stainless steel column 4.6 mm in inside diameter and 25 cm in length, packed with phenylhexylsilanized silica gel for liquid chromatography (5 μ m in particle diameter).

Column temperature: A constant temperature of about 27°C.

Mobile phase A: Dissolve 8.5 g of tetrabutylammonium hydrogensulfate in 80 mL of water, add 3.4 mL of phosphoric acid, and adjust to pH 7.5 with a solution of sodium hydroxide (43 in 100). To 20 mL of this solution add water to make 1000 mL.

Mobile phase B: Dissolve 8.5 g of tetrabutylammonium hydrogensulfate in 80 mL of water, add 3.4 mL of phosphoric acid, and adjust to pH 7.5 with a solution of sodium hydroxide (43 in 100). To 20 mL of this solution add water to make 800 mL, and add 200 mL of acetonitrile.

Flowing of mobile phase: Control the gradient by mixing the mobile phases A and B as directed in the following table.

Time after injection of sample (min)	Mobile phase A (vol%)	Mobile phase B (vol%)
0 - 15	100	0
15 - 35	100 → 0	0 → 100

Flow rate: 0.5 mL per minute.

System suitability—

System performance: To 9 mL of the standard solution add 1 mL of diluted hydrogen peroxide TS (1 in 60), and allow to stand at room temperature for not less than 1 hour. When the procedure is run with 10 μ L of this solution under the above operating conditions, the resolution between the peak of carboplatin and the peak having the relative retention time about 0.93 to carboplatin is not less than 1.2.

System repeatability: When the test is repeated 6 times with 10 μ L of the standard solution under the above operating conditions, the relative standard deviation of the peak area of carboplatin is not more than 1.0%.

Containers and storage Containers—Tight containers.

Storage—Light-resistant.

Carboplatin Injection

カルボプラチン注射液

Carboplatin Injection is an aqueous injection.

It contains not less than 95.0% and not more than 105.0% of the labeled amount of carboplatin (C₆H₁₂N₂O₄Pt: 371.25).

Method of preparation Prepare as directed under Injections, with Carboplatin.

Description Carboplatin Injection is a clear, colorless to pale yellow liquid.

Identification (1) To an amount of Carboplatin Injection, equivalent to 20 mg of Carboplatin, add 2 to 3 drops of diluted tin (II) chloride TS (1 in 15), and allow to stand for 30 minutes: a yellowish brown precipitate is formed.

(2) Evaporate to dryness a volume of Carboplatin Injection, equivalent to 10 mg of Carboplatin, in a water bath at not exceeding 30°C under vacuum. Determine the infrared absorption spectrum of the residue as directed in the potassium bromide disk method under Infrared Spectrophotometry <2.25>: it exhibits absorption at the wave numbers of about 3270 cm⁻¹, 2990 cm⁻¹, 2960 cm⁻¹, 1645 cm⁻¹, 1610 cm⁻¹, 1381 cm⁻¹ and 1348 cm⁻¹.

pH Being specified separately when the drug is granted approval based on the Law.

Purity (1) 1,1-Cyclobutanedicarboxylic acid—To an exact volume of Carboplatin Injection, equivalent to 20 mg of Carboplatin, add the mobile phase to make exactly 10 mL, and use this solution as the sample solution. Separately, weigh accurately about 25 mg of 1,1-cyclobutanedicarboxylic acid, and dissolve in the mobile phase to make exactly 100 mL. Pipet 4 mL of this solution, add the mobile phase to make exactly 50 mL, and use this solution as the standard solution. Perform the test with exactly 25 μ L each of the sample solution and standard solution as directed under Liquid Chromatography <2.01> according to the following conditions. Determine the peak areas, A_T and A_S , of 1,1-cyclobutanedicarboxylic acid in each solution, and calculate

the amount of 1,1-cyclobutanedicarboxylic acid by the following formula: it is not more than 0.7%.

$$\begin{aligned} \text{Amount (\%)} \text{ of 1,1-cyclobutanedicarboxylic acid} \\ = M_S \times A_T/A_S \times 1/25 \end{aligned}$$

M_S : Amount (mg) of 1,1-cyclobutanedicarboxylic acid taken

Operating conditions—

Proceed as directed in the operating conditions in the Purity (1) under Carboplatin.

System suitability—

Proceed as directed in the system suitability in the Purity (1) under Carboplatin.

(2) Related substances—To a volume of Carboplatin Injection, equivalent to 10 mg of Carboplatin, add water to make 10 mL, and use this solution as the sample solution. Perform the test with 10 μ L of the sample solution as directed under Liquid Chromatography <2.01> according to the following conditions, and determine each peak area by the automatic integration method. Calculate the amount of these peaks by the area percentage method: the total amount of the peaks other than carboplatin is not more than 2.0%.

Operating conditions—

Detector, column, column temperature, mobile phases A and B, and flow rate: Proceed as directed in the operating conditions in the Assay under Carboplatin.

Flowing of mobile phase, and time span of measurement: Proceed as directed in the operating conditions in the Purity (2) under Carboplatin.

System suitability—

System performance: Proceed as directed in the system suitability in the Assay under Carboplatin.

Test for required detectability, and system repeatability: Proceed as directed in the system suitability in the Purity (2) under Carboplatin.

Bacterial endotoxins <4.01> Less than 0.2 EU/mg.

Extractable volume <6.05> It meets the requirement.

Foreign insoluble matter <6.06> Perform the test according to Method 1: it meets the requirement.

Insoluble particulate matter <6.07> It meets the requirement.

Sterility <4.06> Perform the test according to the Membrane filtration method: it meets the requirement.

Assay To an exact volume of Carboplatin Injection, equivalent to about 20 mg of carboplatin ($C_6H_{12}N_2O_4Pt$), add water to make exactly 20 mL, and use this solution as the sample solution. Separately, weigh accurately about 25 mg of Carboplatin RS (separately determine the loss on drying <2.41> under the same conditions as Carboplatin), dissolve in water to make exactly 25 mL, and use this solution as the standard solution. Perform the test with exactly 10 μ L each of the sample solution and standard solution as directed under Liquid Chromatography <2.01> according to the following conditions, and determine the peak areas, A_T and A_S , of carboplatin in each solution.

$$\begin{aligned} \text{Amount (mg) of carboplatin (C}_6\text{H}_{12}\text{N}_2\text{O}_4\text{Pt)} \\ = M_S \times A_T/A_S \times 4/5 \end{aligned}$$

M_S : Amount (mg) of Carboplatin RS taken, calculated on the dried basis

Operating conditions—

Detector: An ultraviolet absorption photometer (wavelength: 230 nm).

Column: A stainless steel column 4.0 mm in inside diameter and 25 cm in length, packed with octadecylsilanized silica gel for liquid chromatography (10 μ m in particle diameter).

Column temperature: A constant temperature of about 35°C.

Mobile phase: Dissolve 8.5 g of tetrabutylammonium hydrogensulfate in 80 mL of water, add 3.4 mL of phosphoric acid, and adjust to pH 7.5 with a solution of sodium hydroxide (43 in 100). To 10 mL of this solution add 880 mL of water and 10 mL of acetonitrile.

Flow rate: Adjust so that the retention time of carboplatin is about 4 minutes.

System suitability—

System performance: To a solution of 25 mg of carboplatin in 20 mL of water add 2.5 mL of a solution of 65 mg of 1,3-phenylenediamine hydrochloride in 50 mL of water, and add water to make 25 mL. When the procedure is run with 10 μ L of this solution under the above operating conditions, carboplatin and 1,3-phenylenediamine are eluted in this order with the resolution between these peaks being not less than 2.0.

System repeatability: When the test is repeated 6 times with 10 μ L of the standard solution under the above operating conditions, the relative standard deviation of the peak area of carboplatin is not more than 1.0%.

Containers and storage Containers—Hermetic containers.

Storage—Light-resistant.

Shelf life 24 months after preparation.

Carmellose

Carboxymethylcellulose

カルメロース

[9000-11-7]

This monograph is harmonized with the European Pharmacopoeia and the U.S. Pharmacopoeia.

The parts of the text that are not harmonized are marked with symbols (◆ ◆).

Information on the harmonization with the European Pharmacopoeia and the U.S. Pharmacopoeia is available on the website of the Pharmaceuticals and Medical Devices Agency.

Carmellose is partly *O*-carboxymethylated cellulose.

◆**Description** Carmellose occurs as a white powder.

It is practically insoluble in ethanol (95).

It swells with water to form suspension.

It becomes viscid in sodium hydroxide TS.

It is hygroscopic.◆

Identification (1) Determine the infrared absorption spectrum of Carmellose as directed in the potassium bromide disk method under Infrared Spectrophotometry <2.25>, and compare the spectrum with the Reference Spectrum: both spectra exhibit similar intensities of absorption at the same wave numbers.

(2) The pH <2.54> of a suspension, obtained by shaking 1 g of Carmellose with 100 mL of water, is between 3.5 and 5.0.

Purity (1) Chloride—Shake well 0.8 g of Carmellose with 50 mL of water, add 10 mL of sodium hydroxide TS to dis-

solve, and add water to make 100 mL. Heat 20 mL of this solution with 10 mL of dilute nitric acid in a water bath until a flocculent precipitate is produced, cool, centrifuge, and take out the supernatant liquid. Wash the precipitate with three 10-mL portions of water by centrifuge each time, combine the supernatant liquid and the washings, and add water to make 100 mL. Take 25 mL of this solution in a Nessler tube, add 6 mL of dilute nitric acid and water to make 50 mL, and use this solution as the test solution. Separately, to 0.40 mL of 0.01 mol/L hydrochloric acid VS add 6 mL of dilute nitric acid and water to make 50 mL, and use this solution as the control solution. To the test solution and the control solution add 1 mL each of silver nitrate TS, ♦mix,♦ and allow to stand protected from light for 5 minutes. Compare the opalescence developed in both solutions ♦against a black background by viewing downward or transversely♦. The opalescence in the test solution is not more intense than that in the control solution (not more than 0.36%).

(2) Sulfate—Shake well 0.40 g of Carmellose with 25 mL of water, add 5 mL of sodium hydroxide TS to dissolve, and add 20 mL of water. Heat this solution with 2.5 mL of hydrochloric acid in a water bath until a flocculent precipitate is produced, cool, centrifuge, and take out the supernatant liquid. Wash the precipitate with three 10-mL portions of water by centrifuge each time, combine the supernatant liquid and the washings, and add water to make 100 mL. Filter this solution, discard the first 5 mL of the filtrate, take 25 mL of the subsequent filtrate in a Nessler tube, add 1 mL of dilute hydrochloric acid and water to make 50 mL, and use this solution as the test solution. Separately, to 1.5 mL of 0.005 mol/L sulfuric acid VS add 1 mL of dilute hydrochloric acid and water to make 50 mL, and use this solution as the control solution. To the test solution and the control solution add 2 mL each of barium chloride TS, mix, and allow to stand for 10 minutes. Compare the opalescence developed in both solutions ♦against a black background by viewing downward or transversely♦. The opalescence in the test solution is not more intense than that in the control solution (not more than 0.72%).

♦(3) Heavy metals <1.07>—Proceed with 1.0 g of Carmellose according to Method 2, and perform the test. Prepare the control solution with 2.0 mL of Standard Lead Solution (not more than 20 ppm).♦

Loss on drying <2.41> Not more than 8.0% (1 g, 105°C, 4 hours).

Residue on ignition <2.44> Not more than 1.5% (after drying, 1 g).

♦**Containers and storage** Containers—Tight containers.♦

Carmellose Calcium

Carboxymethylcellulose Calcium

カルメロースカルシウム

[9050-04-8]

This monograph is harmonized with the European Pharmacopoeia and the U.S. Pharmacopoeia.

The parts of the text that are not harmonized are marked with symbols (♦ ♦).

Information on the harmonization with the European Pharmacopoeia and the U.S. Pharmacopoeia is available on the website of the Pharmaceuticals and Medical Devices

Agency.

Carmellose Calcium is the calcium salt of partly *O*-carboxymethylated cellulose.

♦**Description** Carmellose Calcium occurs as a white to yellowish white powder.

It is practically insoluble in ethanol (95) and in diethyl ether.

It swells with water to form a suspension.

The pH of a suspension, obtained by shaking 1.0 g of Carmellose Calcium with 100 mL of water, is between 4.5 and 6.0.

It is hygroscopic.♦

Identification (1) Shake thoroughly 0.1 g of Carmellose Calcium with 10 mL of water, followed by 2 mL of sodium hydroxide TS, allow to stand for 10 minutes, and use this solution as the sample solution. To 1 mL of the sample solution add water to make 5 mL. To 1 drop of this solution add 0.5 mL of chromotropic acid TS, and heat in a water bath for 10 minutes: a red-purple color develops.

(2) Shake 5 mL of the sample solution obtained in (1) with 10 mL of acetone: a white, flocculent precipitate is produced.

(3) Shake 5 mL of the sample solution obtained in (1) with 1 mL of iron (III) chloride TS: a brown, flocculent precipitate is produced.

(4) Ignite 1 g of Carmellose Calcium to ash, dissolve the residue in 10 mL of water and 6 mL of acetic acid (31), and filter, if necessary. Boil the filtrate, cool, and neutralize with ammonia TS: the solution responds to Qualitative Tests <1.09> (1) and (3) for calcium salt.

Purity (1) Alkalinity—Shake thoroughly 1.0 g of Carmellose Calcium with 50 mL of freshly boiled and cooled water, and add 2 drops of phenolphthalein TS: no red color develops.

(2) Chloride <1.03>—Shake thoroughly 0.80 g of Carmellose Calcium with 50 mL of water, add 10 mL of sodium hydroxide TS to dissolved, add water to make 100 mL, and use this solution as the sample solution. Heat 20 mL of the sample solution with 10 mL of 2 mol/L nitric acid TS on a water bath until a flocculent precipitate is produced. After cooling, centrifuge, and take out the supernatant liquid. Wash the precipitate with three 10-mL portions of water by centrifuging each time, combine the supernatant and the washings, and add water to make 100 mL. Take 25 mL of this solution, and add 1 mL of nitric acid and water to make 50 mL. Perform the test using this solution as the test solution. Prepare the control solution with 0.40 mL of 0.01 mol/L hydrochloric acid VS (not more than 0.36%).

(3) Sulfate <1.14>—Heat 10 mL of the sample solution obtained in (2) with 1 mL of hydrochloric acid in a water bath until a flocculent precipitate is produced. Cool, centrifuge, and take out the supernatant liquid. Wash the precipitate with three 10-mL portions of water by centrifuging each time, combine the supernatant and the washings, and add water to make 100 mL. Perform the test with 25 mL this solution as the test solution. Prepare the control solution with 0.42 mL of 0.005 mol/L sulfuric acid VS. To the test solution and the control solution add 1 mL of 3 mol/L hydrochloric acid TS and 3 mL of barium chloride TS, then add water to make 50 mL, and mix. Allow to stand for 10 minutes, and compare the turbidity of these solutions: the turbidity obtained with the test solution is not more than that obtained with the control solution (not more than 1.0%).

◆(4) Heavy metals <1.07>—Proceed with 1.0 g of Carmellose Calcium according to Method 2, and perform the test. Prepare the control solution with 2.0 mL of Standard Lead Solution (not more than 20 ppm).◆

Loss on drying <2.41> Not more than 10.0% (1 g, 105°C, 4 hours).

Residue on ignition <2.44> 10 – 20% (after drying 1 g).

◆**Containers and storage** Containers—Tight containers.◆

Carmellose Sodium

Carboxymethylcellulose Sodium

カルメロースナトリウム

[9004-32-4]

Carmellose Sodium is the sodium salt of partly *O*-carboxymethylated cellulose.

It, when dried, contains not less than 6.5% and not more than 8.5% of sodium (Na: 22.99).

Description Carmellose Sodium occurs as a white to yellowish white, powder or granules. It has no taste.

It is practically insoluble in methanol, in ethanol (95), in acetic acid (100) and in diethyl ether.

It forms a viscid solution in water and in warm water.

It is hygroscopic.

Identification (1) Dissolve 0.2 g of Carmellose Sodium in 20 mL of warm water with stirring, cool, and use this solution as the sample solution. To 1 mL of the sample solution add water to make 5 mL. To 1 drop of this solution add 0.5 mL of concentrated chromotropic acid TS, and heat in a water bath for 10 minutes: a red-purple color develops.

(2) To 10 mL of the sample solution obtained in test (1) add 1 mL of copper (II) sulfate TS: a blue flocculent precipitate is produced.

(3) To 3 g of Carmellose Sodium add 20 mL of methanol and 2 mL of dilute hydrochloric acid, boil gently on a water bath for 5 minutes, and filter. Evaporate the filtrate to dryness, and add 20 mL of water to the residue: the solution responds to Qualitative Tests <1.09> for sodium salt.

pH <2.54> Add 1.0 g of Carmellose Sodium in small portions to 100 mL of warm water with stirring, dissolve, and cool: the pH of this solution is between 6.0 and 8.0.

Purity (1) Clarity and color of solution—Firmly attach a glass plate of good quality 2 mm in thickness, to the bottom of a glass column 250 mm in height, 25 mm in inner diameter and 2 mm in thickness. This is used as an outer tube. Similarly prepare an inner tube by attaching a glass plate of good quality 2 mm in thickness to the bottom of a glass column 300 mm in height, 15 mm in inner diameter and 2 mm in thickness. Dissolve 1.0 g of Carmellose Sodium in 100 mL of water, pour this solution into the outer tube, and place on a piece of white paper on which 15 parallel black lines 1 mm in width and 1 mm in interval are drawn. Moving the inner tube up and down and observing from the upper part, determine the height of the solution up to the lower edge of the inner tube when the distinction of the lines becomes impossible. Repeat the operation 3 times, and calculate the mean value: it is larger than that calculated from the similar operation, using the following control solution.

Control solution: To 5.50 mL of 0.005 mol/L sulfuric acid

VS add 1 mL of dilute hydrochloric acid, 5 mL of ethanol (95) and water to make 50 mL. Add 2 mL of barium chloride TS, mix well, and allow to stand for 10 minutes. Shake well this solution before use.

(2) Chloride <1.03>—Dissolve 0.5 g of Carmellose Sodium in 50 mL of water, and use this solution as the sample solution. Shake 10 mL of the sample solution with 10 mL of dilute nitric acid, heat to produce a flocculent precipitate in a water bath, cool, and centrifuge. Separate the supernatant liquid, wash the precipitate with three 10-mL portions of water, centrifuging each time, combine the supernatant liquid with the washings, and dilute with water to 200 mL. Perform the test using 50 mL of this solution as the test solution. Prepare the control solution with 0.45 mL of 0.01 mol/L hydrochloric acid VS (not more than 0.640%).

(3) Sulfate <1.14>—Add 1 mL of hydrochloric acid to 10 mL of the sample solution obtained in (2), shake well, heat to produce a flocculent precipitate in a water bath, cool, and centrifuge. Separate the supernatant liquid, wash the precipitate with three 10-mL portions of water, centrifuging each time, combine the washings with the supernatant liquid mentioned above, and dilute to 50 mL with water. Take 10 mL of this solution, dilute with water to 50 mL, and perform the test using this solution as the test solution. Prepare the control solution with 0.40 mL of 0.005 mol/L sulfuric acid VS (not more than 0.960%).

(4) Silicate—Weigh accurately about 1 g of Carmellose Sodium, ignite in a platinum dish, add 20 mL of dilute hydrochloric acid, cover with a watch glass, and boil gently for 30 minutes. Remove the watch glass, and evaporate on a water bath to dryness with the aid of a current of air. Continue heating for further 1 hour, add 10 mL of hot water, stir well, and filter through a filter paper for quantitative analysis. Wash the residue with hot water, dry together with the filter paper after no turbidity is produced on the addition of silver nitrate TS to the last washing, and then ignite to constant mass: the mass of the residue is not more than 0.5%.

(5) Heavy metals <1.07>—Proceed with 1.0 g of Carmellose Sodium according to Method 2, and perform the test. Prepare the control solution with 2.0 mL of Standard Lead Solution (not more than 20 ppm).

(6) Arsenic <1.11>—To 1.0 g of Carmellose Sodium add 20 mL of nitric acid, heat gently until it becomes fluid, cool, add 5 mL of sulfuric acid, and heat until white fumes are evolved. Add, if necessary, 5 mL of nitric acid after cooling, and heat again. Repeat this operation until the solution becomes colorless or slightly yellow. After cooling, add 15 mL of a saturated solution of ammonium oxalate monohydrate, and heat until white fumes are evolved again, cool, and dilute with water to 25 mL. Take 5 mL of this solution as the test solution, and perform the test. The solution has no more color than the following color standard.

Color standard: Without using Carmellose Sodium, proceed in the same manner, then transfer 5 mL of this solution to a generator bottle, add exactly 2 mL of Standard Arsenic Solution, and proceed as directed for the test with the test solution (not more than 10 ppm).

(7) Starch—Add 2 drops of iodine TS to 10 mL of the sample solution obtained in (2): no blue color develops.

Loss on drying <2.41> Not more than 10.0% (1 g, 105°C, 4 hours).

Assay Weigh accurately about 0.5 g of Carmellose Sodium, previously dried, add 80 mL of acetic acid (100), connect with a reflux condenser, and heat in an oil bath maintained at 130°C for 2 hours. Cool, and titrate <2.50> with 0.1 mol/L perchloric acid VS (potentiometric titration). Per-

form a blank determination in the same manner, and make any necessary correction.

$$\begin{aligned} \text{Each mL of 0.1 mol/L perchloric acid VS} \\ = 2.299 \text{ mg of Na} \end{aligned}$$

Containers and storage Containers—Tight containers.

Croscarmellose Sodium

クロスカルメロースナトリウム

[74811-65-7]

This monograph is harmonized with the European Pharmacopoeia and the U.S. Pharmacopoeia.

The parts of the text that are not harmonized are marked with symbol (◆ ◆).

Information on the harmonization with the European Pharmacopoeia and the U.S. Pharmacopoeia is available on the website of the Pharmaceuticals and Medical Devices Agency.

Croscarmellose Sodium is the sodium salt of cross-linked, partly *O*-carboxymethylated cellulose.

◆**Description** Croscarmellose Sodium occurs as a white to yellowish white powder.

It is practically insoluble in ethanol (99.5) and in diethyl ether.

It swells with water and becomes a suspension.

It is hygroscopic.◆

Identification (1) To 1 g of Croscarmellose Sodium add 100 mL of a solution of methylene blue (1 in 250,000), stir well, and allow to stand: blue cotton-like precipitates appear.

(2) To 1 g of Croscarmellose Sodium add 50 mL of water, and stir well to make a suspension. To 1 mL of this suspension add 1 mL of water and 5 drops of freshly prepared solution of 1-naphthol in methanol (1 in 25), and gently add 2 mL of sulfuric acid along a wall of the vessel: a red-purple color appears at the zone of contact.

(3) The suspension obtained in (2) responds to Qualitative Tests <1.09> (1) for sodium salt.

pH <2.54> To 1.0 g of Croscarmellose Sodium add 100 mL of water, and stir for 5 minutes: the pH of the supernatant liquid is between 5.0 and 7.0.

Purity ◆**(1)** Heavy metals <1.07>—Proceed with 2.0 g of Croscarmellose Sodium according to Method 2, and perform the test. Prepare the control solution with 2.0 mL of Standard Lead Solution (not more than 10 ppm).◆

◆**(2)** Sodium chloride and sodium glycolate—The total amount of sodium chloride and sodium glycolate is not more than 0.5%, calculated on the dried basis.

(i) Sodium chloride: Weigh accurately about 5 g of Croscarmellose Sodium, add 50 mL of water and 5 mL of hydrogen peroxide (30), and heat on a water bath for 20 minutes with occasional stirring. After cooling, add 100 mL of water and 10 mL of nitric acid, and titrate <2.50> with 0.1 mol/L silver nitrate VS (potentiometric titration). Perform a blank determination in the same manner, and make any necessary correction.

$$\begin{aligned} \text{Each mL of 0.1 mol/L silver nitrate VS} \\ = 5.844 \text{ mg of NaCl} \end{aligned}$$

(ii) Sodium glycolate: Weigh accurately about 0.5 g of

Croscarmellose Sodium, add 2 mL of acetic acid (100) and 5 mL of water, and stir for 15 minutes. Add gradually 50 mL of acetone with stirring, then add 1 g of sodium chloride, stir for 3 minutes, and filter through a filter paper moistened with acetone. Wash the residue thoroughly with 30 mL of acetone, combine the filtrate and washings, add acetone to make exactly 100 mL, and use this solution as the sample stock solution. Separately, dissolve 0.100 g of glycolic acid in water to make 200 mL. Pipet 0.5 mL, 1 mL, 2 mL, 3 mL and 4 mL of this solution, add water to make them exactly 5 mL, then add 5 mL of acetic acid (100) and acetone to make exactly 100 mL, and designate them standard stock solution (1), standard stock solution (2), standard stock solution (3), standard stock solution (4) and standard stock solution (5), respectively. Pipet 2 mL each of the sample stock solution and the standard stock solutions (1), (2), (3), (4) and (5), and heat them in a water bath for 20 minutes to evaporate acetone. After cooling, add exactly 5 mL of 2,7-dihydroxynaphthalene TS, mix, then add 15 mL of 2,7-dihydroxynaphthalene TS, mix, cover the mouth of the vessels with aluminum foil, and heat in a water bath for 20 minutes. After cooling, add sulfuric acid to make exactly 25 mL, mix, and designate them sample solution, standard solution (1), standard solution (2), standard solution (3), standard solution (4) and standard solution (5), respectively. Separately, to 10 mL of a mixture of water and acetic acid (100) (1:1) add acetone to make exactly 100 mL, and proceed with exactly 2 mL of this solution in the same manner for preparation of the blank solution, and use the solution so obtained as the blank solution. Determine the absorbances, A_T , A_{S1} , A_{S2} , A_{S3} , A_{S4} and A_{S5} , of the sample solution and the standard solutions (1), (2), (3), (4) and (5), respectively, at 540 nm as directed under Ultraviolet-visible Spectrophotometry <2.24>, using the blank solution as the control. Determine the amount (g) of glycolic acid, X , in 100 mL of the sample stock solution from the calibration curve obtained with the standard solutions, and calculate the amount of sodium glycolate by the following formula.

$$\begin{aligned} \text{Amount (\%)} \text{ of sodium glycolate} \\ = X/M \times 100 \times 1.289 \end{aligned}$$

M : Amount (g) of sample taken, calculated on the dried basis.◆

◆**(3)** Water-soluble substance—Weigh accurately about 10 g of Croscarmellose Sodium, disperse in 800 mL of water by stirring for 1 minute every 10 minutes during 30 minutes, and allow to stand for at most 1 hour to precipitate. Filter by suction or centrifuge the clear upper portion, and weigh accurately the mass of about 150 mL of the filtrate or supernatant liquid. Heat to concentrate this liquid avoiding to dryness, then dry at 105°C for 4 hours, and weigh the mass of the residue accurately. Calculate the amount of the water-soluble substance by the following formula: not less than 1.0% and not more than 10.0%.

$$\begin{aligned} \text{Amount (\%)} \text{ of water-soluble substance} \\ = 100 M_3 (800 + M_1)/M_1 M_2 \end{aligned}$$

M_1 : Amount (g) of sample taken, calculated on the dried basis

M_2 : Amount (g) of the filtrate or supernatant liquid of about 150 mL

M_3 : Amount (g) of the residue.◆

Precipitation test Put 75 mL of water in a 100-mL glass-stoppered graduated cylinder, and add portion by portion with 1.5 g of Croscarmellose Sodium divided into three portions while shaking vigorously at each time. Then, add water

to make 100 mL, shake until to get a homogenous dispersion, and allow to stand for 4 hours: the volume of the settled layer is not less than 10.0 mL and not more than 30.0 mL.

Degree of substitution Weigh accurately about 1 g of Croscarmellose Sodium, put in a 500-mL glass-stoppered conical flask, add 300 mL of sodium chloride TS, then add 25.0 mL of 0.1 mol/L sodium hydroxide VS, stopper, and allow to stand for 5 minutes with occasional shaking. Add 5 drops of *m*-cresol purple TS, then add exactly 15 mL of 0.1 mol/L hydrochloric acid VS using a buret, stopper the flask, and shake. If the color of the solution is purple, add exactly 1-mL portions of 0.1 mol/L hydrochloric acid VS using the buret, with shaking each time, until the color of the solution changes to yellow, then titrate <2.50> with 0.1 mol/L sodium hydroxide VS until the color changes from yellow to purple. Perform a blank determination in the same manner. Calculate the degrees of substitution of acid-carboxymethyl group and sodium-carboxymethyl group, *A* and *S*: *A* + *S* is not less than 0.60 and not more than 0.85.

$$A = 1150M / (7102 - 412M - 80C)$$

$$S = (162 + 58A)C / (7102 - 80C)$$

M: Amount (mmol) of sodium hydroxide needed to neutralize 1 g of sample taken, calculated on the dried basis

C: The value (%) obtained in Residue on ignition

Loss on drying <2.41> Not more than 10.0% (1 g, 105°C, 6 hours).

Residue on ignition <2.44> 14.0 – 28.0% (after drying, 1 g).

Containers and storage Containers—Tight containers.

Carmofur

カルモフル

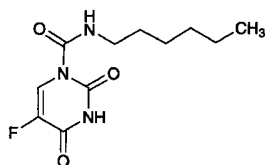

$C_{11}H_{16}FN_3O_3$; 257.26

5-Fluoro-1-(hexylaminocarbonyl)uracil

[61422-45-5]

Carmofur, when dried, contains not less than 98.0% of carmofur ($C_{11}H_{16}FN_3O_3$).

Description Carmofur occurs as a white crystalline powder.

It is very soluble in *N,N*-dimethylformamide, freely soluble in acetic acid (100), soluble in diethyl ether, sparingly soluble in methanol and in ethanol (99.5), and practically insoluble in water.

Melting point: about 111°C (with decomposition).

Identification (1) Proceed with 5 mg of Carmofur as directed under Oxygen Flask Combustion Method <1.06>, using a mixture of 0.5 mL of 0.01 mol/L sodium hydroxide TS and 20 mL of water as the absorbing liquid, and prepare the test solution: the test solution responds to Qualitative Tests <1.09> (2) for fluoride.

(2) Determine the absorption spectrum of a solution of

Carmofur in a mixture of methanol and phosphoric acid-acetic acid-boric acid buffer solution (pH 2.0) (9:1) (1 in 100,000) as directed under Ultraviolet-visible Spectrophotometry <2.24>, and compare the spectrum with the Reference Spectrum: both spectra exhibit similar intensities of absorption at the same wavelengths.

(3) Determine the infrared absorption spectrum of Carmofur, previously dried, as directed in the potassium bromide disk method under Infrared Spectrophotometry <2.25>, and compare the spectrum with the Reference Spectrum: both spectra exhibit similar intensities of absorption at the same wave numbers.

Purity (1) Heavy metals <1.07>—Proceed with 2.0 g of Carmofur according to Method 2, and perform the test. Prepare the control solution with 2.0 mL of Standard Lead Solution (not more than 10 ppm).

(2) Related substances—Dissolve 0.20 g of Carmofur in 10 mL of a mixture of methanol and acetic acid (100) (99:1), and use this solution as the sample solution. Pipet 1 mL of the sample solution, add a mixture of methanol and acetic acid (100) (99:1) to make exactly 500 mL, and use this solution as the standard solution. Perform the test with these solutions as directed under Thin-layer Chromatography <2.03>. Spot 15 μL each of the sample solution and standard solution on a plate of silica gel with fluorescent indicator for thin-layer chromatography. Develop the plate with a mixture of toluene and acetone (5:3) to a distance of about 12 cm, and air-dry the plate. Examine under ultraviolet light (main wavelength: 254 nm): the spots other than the principal spot from the sample solution are not more intense than the spot from the standard solution. After exposure of the plate to bromine vapor for 30 second, spray evenly a solution of fluorescein in ethanol (95) (1 in 2500): the spots other than the principal spot obtained from the sample solution are not more intense than the spot from the standard solution.

Loss on drying <2.41> Not more than 0.5% (1 g, in vacuum, 50°C, 3 hours).

Residue on ignition <2.44> Not more than 0.1% (1 g).

Assay Weigh accurately about 0.5 g of Carmofur, previously dried, dissolve in 20 mL of *N,N*-dimethylformamide, and titrate <2.50> with 0.1 mol/L tetramethylammonium hydroxide-methanol VS until the color of the solution changes from yellow through blue-green to blue (indicator: 3 drops of thymol blue-dimethylformamide TS).

Each mL of 0.1 mol/L tetramethylammonium hydroxide-methanol VS
= 25.73 mg of $C_{11}H_{16}FN_3O_3$

Containers and storage Containers—Tight containers.

Carteolol Hydrochloride

カルテオロール塩酸塩

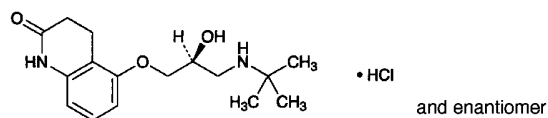

$C_{16}H_{24}N_2O_3 \cdot HCl$: 328.83
5-[(2*RS*)-3-(1,1-Dimethylethyl)amino-2-hydroxypropyloxy]-3,4-dihydroquinolin-2(1*H*)-one monohydrochloride
[51781-21-6]

Carteolol Hydrochloride, when dried, contains not less than 99.0% of carteolol hydrochloride ($C_{16}H_{24}N_2O_3 \cdot HCl$).

Description Carteolol Hydrochloride occurs as white, crystals or crystalline powder.

It is soluble in water, sparingly soluble in methanol, very slightly soluble in ethanol (95) and in acetic acid (100), and practically insoluble in diethyl ether.

The pH of a solution of 1.0 g of Carteolol Hydrochloride in 100 mL of water is between 5.0 and 6.0.

The solution of Carteolol Hydrochloride (1 in 20) shows no optical rotation.

Melting point: about 277°C (with decomposition).

Identification (1) Dissolve 0.1 g of Carteolol Hydrochloride in 5 mL of water, and add 5 drops of Reinecke salt TS: a light red precipitate is formed.

(2) Determine the absorption spectrum of a solution of Carteolol Hydrochloride (1 in 100,000) as directed under Ultraviolet-visible Spectrophotometry <2.24>, and compare the spectrum with the Reference Spectrum: both spectra exhibit similar intensities of absorption at the same wavelengths.

(3) Determine the infrared absorption spectrum of Carteolol Hydrochloride as directed in the potassium chloride disk method under Infrared Spectrophotometry <2.25>, and compare the spectrum with the Reference Spectrum: both spectra exhibit similar intensities of absorption at the same wave numbers.

(4) A solution of Carteolol Hydrochloride (1 in 50) responds to Qualitative Tests <1.09> for chloride.

Purity (1) Clarity and color of solution—Dissolve 1.0 g of Carteolol Hydrochloride in 30 mL of water: the solution is clear and colorless.

(2) Heavy metals <1.07>—Proceed with 2.0 g of Carteolol Hydrochloride according to Method 2, and perform the test. Prepare the control solution with 2.0 mL of Standard Lead Solution (not more than 10 ppm).

(3) Arsenic <1.11>—Prepare the test solution with 1.0 g of Carteolol Hydrochloride according to Method 3, and perform the test (not more than 2 ppm).

(4) Related substances—Dissolve 0.20 g of Carteolol Hydrochloride in 10 mL of methanol, and use this solution as the sample solution. Pipet 2 mL of the sample solution, and add methanol to make exactly 100 mL. Pipet 1 mL of this solution, add methanol to make exactly 10 mL, and use this solution as the standard solution. Perform the test with these solutions as directed under Thin-layer Chromatography <2.03>. Spot 10 μ L each of the sample solution and standard solution on a plate of silica gel with fluorescent indicator for thin-layer chromatography. Develop the plate with a mixture

of chloroform, methanol and ammonia solution (28) (50:20:1) to a distance of about 12 cm, and air-dry the plate. Examine under ultraviolet light (main wavelength: 254 nm): the spots other than the principal spot obtained from the sample solution are not more intense than the spot from the standard solution.

Loss on drying <2.41> Not more than 0.5% (1 g, 105°C, 3 hours).

Residue on ignition <2.44> Not more than 0.1% (1 g).

Assay Weigh accurately about 0.5 g of Carteolol Hydrochloride, previously dried, add 30 mL of acetic acid (100), dissolve by heating on a water bath, and cool. After adding 70 mL of acetic anhydride, titrate <2.50> with 0.1 mol/L perchloric acid VS (potentiometric titration). Perform a blank determination in the same manner, and make any necessary correction.

Each mL of 0.1 mol/L perchloric acid VS
= 32.88 mg of $C_{16}H_{24}N_2O_3 \cdot HCl$

Containers and storage Containers—Well-closed containers.

Carumonam Sodium

カルモナムナトリウム

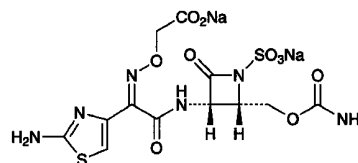

$C_{12}H_{12}N_6Na_2O_{10}S_2$: 510.37
Disodium (*Z*)-{(2-aminothiazol-4-yl)[(2*S*,3*S*)-2-carbamoyloxymethyl-4-oxo-1-sulfonatoacetazetidin-3-ylcarbamoyl]methylaminoxy}acetate
[86832-68-0]

Carumonam Sodium contains not less than 850 μ g (potency) and not more than 920 μ g (potency) per mg, calculated on the anhydrous basis. The potency of Carumonam Sodium is expressed as mass (potency) of carumonam ($C_{12}H_{14}N_6O_{10}S_2$: 466.40).

Description Carumonam Sodium occurs as a white to yellowish white, crystals or crystalline powder.

It is freely soluble in water, soluble in formamide, very slightly soluble in methanol, and practically insoluble in ethanol (99.5) and in acetic acid (100).

Identification (1) Determine the absorption spectrum of a solution of Carumonam Sodium (3 in 100,000) as directed under Ultraviolet-visible Spectrophotometry <2.24>, and compare the spectrum with the Reference Spectrum or the spectrum of a solution of Carumonam Sodium RS prepared in the same manner as the sample solution: both spectra exhibit similar intensities of absorption at the same wavelengths.

(2) Determine the infrared absorption spectrum of Carumonam Sodium as directed in the potassium bromide disk method under Infrared Spectrophotometry <2.25>, and compare the spectrum with the Reference Spectrum or the spectrum of Carumonam Sodium RS: both spectra exhibit similar intensities of absorption at the same wave numbers.

(3) Determine the 1H spectrum of a solution of

Carumonam Sodium in heavy water for nuclear magnetic resonance spectroscopy (1 in 10) as directed under Nuclear Magnetic Resonance Spectroscopy <2.21>, using sodium 3-trimethylsilylpropionate- d_4 for nuclear magnetic resonance spectroscopy as an internal reference compound: it exhibits a doublet signal A at around δ 5.5 ppm, and a singlet signal B at around δ 7.0 ppm. The ratio of the integrated intensity of these signals, A:B, is about 1:1.

(4) Carumonam Sodium responds to Qualitative Tests <1.09> (1) for sodium salt.

Optical rotation <2.49> $[\alpha]_D^{20}$: +18.5 – +21.0° (0.1 g calculated on the anhydrous basis, water, 10 mL, 100 mm).

pH <2.54> The pH of a solution obtained by dissolving 1.0 g of Carumonam Sodium in 10 mL of water is between 5.0 and 6.5.

Purity (1) Clarity and color of solution—Dissolve 0.5 g of Carumonam Sodium in 5 mL of water: the solution is clear and colorless to pale yellow.

(2) Heavy metals <1.07>—Proceed with 2.0 g of Carumonam Sodium according to Method 2, and perform the test. Prepare the control solution with 3.0 mL of Standard Lead Solution (not more than 15 ppm).

(3) Arsenic <1.11>—Prepare the test solution with 2.0 g of Carumonam Sodium according to Method 4, and perform the test (not more than 1 ppm).

(4) Related substance 1—Weigh accurately about 0.1 g of Carumonam Sodium, and dissolve in the mobile phase to make exactly 50 mL. Pipet 5 mL of this solution, add the mobile phase to make exactly 25 mL, and use this solution as the sample solution. Separately, weigh accurately about 0.1 g of Carumonam Sodium RS, and dissolve in the mobile phase to make exactly 50 mL. Pipet 5 mL of this solution, and add the mobile phase to make exactly 25 mL. Pipet 1 mL of this solution, add the mobile phase to make exactly 100 mL, and use this solution as the standard solution. Perform the test with exactly 10 μ L each of the sample solution and standard solution as directed under Liquid Chromatography <2.01> according to the following conditions, and determine each peak area by the automatic integration method. Calculate the amount of the related substances by the following equation: the amount of the related substance having the relative retention time of about 0.7 to carumonam is not more than 4.0%, and each amount of the related substances other than the related substance having the relative retention time of about 0.7 is not more than 1.0%.

$$\begin{aligned} \text{Amount (\%)} & \text{ of related substance} \\ & = M_S/M_T \times A_T/A_S \end{aligned}$$

M_S : Amount (g) of Carumonam Sodium RS taken
 M_T : Amount (g) of Carumonam Sodium taken
 A_S : Peak area of carumonam from the standard solution
 A_T : Each peak area other than carumonam from the sample solution

Operating conditions—

Detector, column, column temperature, mobile phase, and flow rate: Proceed as directed in the operating conditions in the Assay.

Time span of measurement: About 3 times as long as the retention time of carumonam.

System suitability—

Test for required detectability: Measure exactly 5 mL of the standard solution, and add the mobile phase to make exactly 50 mL. Confirm that the peak area of carumonam obtained with 10 μ L of this solution is equivalent to 7 to 13% of that with 10 μ L of the standard solution.

System performance: Dissolve 40 mg of Carumonam Sodium in 20 mL of the mobile phase. To 5 mL of this solution add 5 mL of a solution of resorcinol in the mobile phase (9 in 1000) and the mobile phase to make 25 mL. When the procedure is run with 10 μ L of this solution under the above operating conditions, resorcinol and carumonam are eluted in this order with the resolution between these peaks being not less than 2.5.

System repeatability: When the test is repeated 3 times with 10 μ L of the standard solution under the above operating conditions, the relative standard deviation of the peak area of carumonam is not more than 2.0%.

(5) Related substance 2—Weigh accurately about 0.1 g of Carumonam Sodium, and dissolve in the mobile phase to make exactly 50 mL. Pipet 5 mL of this solution, add the mobile phase to make exactly 25 mL, and use this solution as the sample solution. Separately, weigh accurately about 0.1 g of Carumonam Sodium RS, and dissolve in the mobile phase to make exactly 50 mL. Pipet 5 mL of this solution, and add the mobile phase to make exactly 25 mL. Pipet 1 mL of this solution, add the mobile phase to make exactly 100 mL, and use this solution as the standard solution. Perform the test with exactly 10 μ L each of the sample solution and standard solution as directed under Liquid Chromatography <2.01> according to the following conditions, and determine each peak area by the automatic integration method. Calculate the amount of the related substances by the following equation: the amount of each related substance is not more than 1.0%.

$$\begin{aligned} \text{Amount (\%)} & \text{ of related substance} \\ & = M_S/M_T \times A_T/A_S \end{aligned}$$

M_S : Amount (g) of Carumonam Sodium RS taken
 M_T : Amount (g) of Carumonam Sodium taken
 A_S : Peak area of carumonam from the standard solution
 A_T : Each area of the peaks appeared after the peak of carumonam from the sample solution

Operating conditions—

Detector, column, and column temperature: Proceed as directed in the operating conditions in the Assay.

Mobile phase: A mixture of a solution of ammonium sulfate (1 in 10,000), methanol and acetic acid (100) (74:25:1).

Flow rate: Dissolve 0.01 g of phthalic acid in the mobile phase to make 100 mL. Adjust so that the retention time of phthalic acid is about 6.5 minutes when the procedure is run with 10 μ L of this solution.

Time span of measurement: About 10 times as long as the retention time of carumonam.

System suitability—

Test for required detectability: Measure exactly 5 mL of the standard solution, and add the mobile phase to make exactly 50 mL. Confirm that the peak area of carumonam obtained with 10 μ L of this solution is equivalent to 7 to 13% of that with 10 μ L of the standard solution.

System performance: Dissolve 40 mg of Carumonam Sodium in 20 mL of the mobile phase. To 5 mL of this solution add 5 mL of a solution of resorcinol in the mobile phase (9 in 1000) and the mobile phase to make 25 mL. When the procedure is run with 10 μ L of this solution under the above operating conditions, resorcinol and carumonam are eluted in this order with the resolution between these peaks being not less than 7.

System repeatability: When the test is repeated 3 times with 10 μ L of the standard solution under the above operating conditions, the relative standard deviation of the peak area of carumonam is not more than 2.0%.

(6) Total amount of related substances—The total of the amounts of the related substances obtained in the Related substance 1 and the Related substance 2 is not more than 6.0%.

Water <2.48> Not more than 2.0% (0.2 g, volumetric titration, direct titration; Use a mixture of formamide for water determination and methanol for water determination (3:1) instead of methanol for water determination).

Assay Weigh accurately an amount of Carumonam Sodium and Carumonam Sodium RS, equivalent to about 40 mg (potency), and dissolve each in the mobile phase to make exactly 20 mL. Measure exactly 5 mL each of these solutions, add exactly 5 mL of the internal standard solution and the mobile phase to make 25 mL, and use these solutions as the sample solution and standard solution. Perform the test with 10 μ L each of the sample solution and standard solution as directed under Liquid Chromatography <2.01> according to the following conditions, and calculate the ratios, Q_T and Q_S , of the peak area of carumonam to that of the internal standard.

$$\text{Amount } [\mu\text{g (potency)}] \text{ of carumonam (C}_{12}\text{H}_{14}\text{N}_6\text{O}_{10}\text{S}_2) \\ = M_S \times Q_T/Q_S \times 1000$$

M_S : Amount [mg (potency)] of Carumonam Sodium RS taken

Internal standard solution—A solution of resorcinol in the mobile phase (9 in 1000).

Operating conditions—

Detector: An ultraviolet absorption photometer (wavelength: 254 nm).

Column: A stainless steel column 4 mm in inside diameter and 15 cm in length, packed with octadecylsilanized silica gel for liquid chromatography (5 μ m in particle diameter).

Column temperature: A constant temperature of about 25°C.

Mobile phase: A mixture of a solution of ammonium sulfate (1 in 10,000), methanol and acetic acid (100) (97:2:1).

Flow rate: Adjust so that the retention time of carumonam is about 10 minutes.

System suitability—

System performance: When the procedure is run with 10 μ L of the standard solution under the above operating conditions, the internal standard and carumonam are eluted in this order with the resolution between these peaks being not less than 2.5.

System repeatability: When the test is repeated 6 times with 10 μ L of the standard solution under the above operating conditions, the relative standard deviation of the ratios of the peak area of carumonam to that of the internal standard is not more than 1.0%.

Containers and storage Containers—Hermetic containers.

Storage—Light-resistant.

Carvedilol

カルベジロール

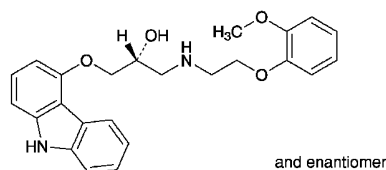

$\text{C}_{24}\text{H}_{26}\text{N}_2\text{O}_4$: 406.47

(2*RS*)-1-(9*H*-Carbazol-4-yloxy)-

3-[2-(2-methoxyphenoxy)ethyl]amino}propan-2-ol
[72956-09-3]

Carvedilol, when dried, contains not less than 99.0% and not more than 101.0% of carvedilol ($\text{C}_{24}\text{H}_{26}\text{N}_2\text{O}_4$).

Description Carvedilol occurs as white to pale yellow-white, crystals or crystalline powder.

It is freely soluble in acetic acid (100), sparingly soluble in methanol, slightly soluble in ethanol (99.5), and practically insoluble in water.

A solution of Carvedilol in methanol (1 in 100) shows no optical rotation.

Identification (1) Determine the absorption spectrum of a solution of Carvedilol in methanol (1 in 200,000) as directed under Ultraviolet-visible Spectrophotometry <2.24>, and compare the spectrum with the Reference Spectrum: both spectra exhibit similar intensities of absorption at the same wavelengths.

(2) Determine the infrared absorption spectrum of Carvedilol as directed in the potassium bromide disk method under Infrared Spectrophotometry <2.25>, and compare the spectrum with the Reference Spectrum: both spectra exhibit similar intensities of absorption at the same wave numbers.

Melting point <2.60> 114 – 119°C

Purity (1) Heavy metals <1.07>—Wrap 2.0 g of Carvedilol with a filter paper for quantitative analysis, then proceed according to Method 4, and perform the test. Prepare the control solution as follows: Put a filter paper for quantitative analysis in a crucible, add 10 mL of a solution of magnesium nitrate hexahydrate in ethanol (95) (1 in 10), then proceed as directed for the test solution, and add 2.0 mL of Standard Lead Solution and water to make 50 mL (not more than 10 ppm).

(2) Related substances—Dissolve 65 mg of Carvedilol in 100 mL of the mobile phase. To 1 mL of this solution add the mobile phase to make 10 mL, and use this solution as the sample solution. Pipet 1 mL of the sample solution, add the mobile phase to make exactly 100 mL, and use this solution as the standard solution. Perform the test with exactly 20 μ L each of the sample solution and standard solution as directed under Liquid Chromatography <2.01> according to the following conditions. Determine each peak area by the automatic integration method: the area of the peak other than carvedilol obtained from the sample solution is not larger than 3/20 times the peak area of carvedilol from the standard solution, and the total area of the peaks other than carvedilol from the sample solution is not larger than 1/2 times the peak area of carvedilol from the standard solution.

Operating conditions—

Detector: An ultraviolet absorption photometer (wavelength: 240 nm).

Column: A stainless steel column 4.6 mm in inside diameter and 15 cm in length, packed with octylsilanized silica gel for liquid chromatography (5 μ m in particle diameter).

Column temperature: A constant temperature of about 55°C.

Mobile phase: Dissolve 2.72 g of potassium dihydrogen phosphate in 900 mL of water, adjust to pH 2.0 with phosphoric acid, and add water to make 1000 mL. To 650 mL of this solution add 350 mL of acetonitrile.

Flow rate: Adjust so that the retention time of carvedilol is about 4 minutes.

Time span of measurement: About 9 times as long as the retention time of carvedilol, beginning after the solvent peak.

System suitability—

Test for required detectability: Pipet 2 mL of the standard solution, add the mobile phase to make exactly 20 mL. Confirm that the peak area of carvedilol obtained with 20 μ L of this solution is equivalent to 7 to 13% of that with 20 μ L of the standard solution.

System performance: When the procedure is run with 20 μ L of the standard solution under the above operating conditions, the number of theoretical plates and the symmetry factor of the peak of carvedilol are not less than 6000 and not more than 1.5, respectively.

System repeatability: When the test is repeated 6 times with 20 μ L of the standard solution under the above operating conditions, the relative standard deviation of the peak area of carvedilol is not more than 2.0%.

Loss on drying <2.41> Not more than 0.5% (1 g, 105°C, 2 hours).

Residue on ignition <2.44> Not more than 0.1% (1 g).

Assay Weigh accurately about 0.5 g of Carvedilol, previously dried, dissolve in 60 mL of acetic acid (100), and titrate <2.50> with 0.1 mol/L perchloric acid VS (potentiometric titration). Perform the blank determination in the same manner, and make any necessary correction.

Each mL of 0.1 mol/L perchloric acid VS
= 40.65 mg of C₂₄H₂₆N₂O₄

Containers and storage Containers—Tight containers.

Carvedilol Tablets

カルベジロール錠

Carvedilol Tablets contain not less than 95.0% and not more than 105.0% of the labeled amount of carvedilol (C₂₄H₂₆N₂O₄: 406.47).

Method of preparation Prepare as directed under Tablets, with Carvedilol.

Identification Powder Carvedilol Tablets. To a portion of the powder, equivalent to 20 mg of Carvedilol, add 10 mL of methanol, shake well, and filter. To 0.5 mL of the filtrate add methanol to make 200 mL, and determine the absorption spectrum of this solution as directed under Ultraviolet-visible Spectrophotometry <2.24>: it exhibits maxima between 222 nm and 226 nm, between 241 nm and 245 nm, between 284 nm and 288 nm, between 317 nm and 321 nm and between 330 nm and 334 nm.

Purity Related substances—In this procedure the sample solution should be stored not exceeding 5°C and used within

24 hours after preparation. Powder Carvedilol Tablets. Dissolve a portion of the powder, equivalent to 12.5 mg of Carvedilol, add an adequate amount of the mobile phase and disperse the particles with the aid of ultrasonic waves, if necessary, add the mobile phase to make 100 mL, and shake for 30 minutes. Filter through a membrane filter with a pore size not exceeding 0.22 μ m, discard the first 5 mL of the filtrate, and use the subsequent filtrate as the sample solution. Pipet 1 mL of the sample solution, add the mobile phase to make exactly 100 mL, and use this solution as the standard solution. Perform the test with exactly 50 μ L each of the sample solution and standard solution as directed under Liquid Chromatography <2.01> according to the following conditions, and determine each peak area by the automatic integration method: the area of the two peaks, having the relative retention time between 1.7 and 1.9 and between 2.0 and 3.1 to carvedilol, obtained from the sample solution of 1.25-mg or 2.5-mg tablet is not larger than 3/10 times and 1.6 times the peak area of carvedilol from the standard solution, respectively, the area of the peak other than carvedilol and the peaks mentioned above from the sample solution is not larger than 1/5 times the peak area of carvedilol from the standard solution, and the total area of the peaks other than carvedilol from the sample solution is not larger than 2.2 times the peak area of carvedilol from the standard solution. The area of the two peaks, having the relative retention time between 1.7 and 1.9 and between 2.0 and 3.1, from the sample solution of 10-mg or 20-mg tablet is not larger than 1/10 times and 2/5 times the peak area of carvedilol from the standard solution, respectively, the area of the peak other than carvedilol and the peak mentioned above from the sample solution is not larger than 1/10 times the peak area of carvedilol from the standard solution, and the total area of the peaks other than carvedilol from the sample solution is not larger than 3/5 times the peak area of carvedilol from the standard solution. For the area of the peak, having the relative retention time between 1.7 and 1.9 to carvedilol, multiply the correction factor 1.25.

Operating conditions—

Detector, column, column temperature, mobile phase, and flow rate: Proceed as directed in the operating conditions in the Assay.

Time span of measurement: About 10 times as long as the retention time of carvedilol, beginning after the solvent peak.

System suitability—

Test for required detectability: To exactly 5 mL of the standard solution add the mobile phase to make exactly 100 mL. Confirm that the peak area of carvedilol obtained with 50 μ L of this solution is equivalent to 3.5 to 6.5% of that with 50 μ L of the standard solution.

System performance: When the procedure is run with 50 μ L of the standard solution under the above operating conditions, the number of theoretical plates and the symmetry factor of the peak of carvedilol are not less than 3000 and not more than 2.0, respectively.

System repeatability: When the test is repeated 6 times with 50 μ L of the standard solution under the above operating conditions, the relative standard deviation of the peak area of carvedilol is not more than 1.0%.

Uniformity of dosage units <6.02> Perform the test according to the following method: it meets the requirement of the Content uniformity test.

To 1 tablet of Carvedilol Tablets add 70 mL of a mixture of 0.1 mol/L hydrochloric acid TS and methanol (1:1), shake until the tablet is completely disintegrated, then add a

mixture of 0.1 mol/L hydrochloric acid TS and methanol (1:1) to make exactly 100 mL, and filter through a membrane filter with a pore size not exceeding 0.45 μm . Discard the first 10 mL of the filtrate, pipet V mL of the subsequent filtrate, add a mixture of 0.1 mol/L hydrochloric acid TS and methanol (1:1) to make exactly V' mL so that each mL contains about 5 μg of carvedilol ($\text{C}_{24}\text{H}_{26}\text{N}_2\text{O}_4$), and use this solution as the sample solution. Separately, weigh accurately about 25 mg of carvedilol for assay, previously dried at 105°C for 2 hours, and dissolve in a mixture of 0.1 mol/L hydrochloric acid TS and methanol (1:1) to make exactly 100 mL. Pipet 2 mL of this solution, add a mixture of 0.1 mol/L hydrochloric acid TS and methanol (1:1) to make exactly 100 mL, and use this solution as the standard solution. Determine the absorbances, A_T and A_S , of the sample solution and standard solution at 240 nm as directed under Ultraviolet-visible Spectrophotometry <2.24>.

$$\begin{aligned} &\text{Amount (mg) of carvedilol (C}_{24}\text{H}_{26}\text{N}_2\text{O}_4) \\ &= M_S \times A_T/A_S \times V'/V \times 1/50 \end{aligned}$$

M_S : Amount (mg) of carvedilol for assay taken

Dissolution <6.10> (1) 10-mg tablet and 20-mg tablet

When the test is performed at 75 revolutions per minute according to the Paddle method, using 900 mL of 0.05 mol/L acetic acid-sodium acetate buffer solution (pH 4.0) as the dissolution medium, the dissolution rate in 30 minutes of Carvedilol Tablets is not less than 80%.

Start the test with 1 tablet of Carvedilol Tablets, withdraw not less than 20 mL of the medium at the specified minute after starting the test, and filter through a membrane filter with a pore size not exceeding 0.45 μm . Discard not less than 10 mL of the first filtrate, pipet V mL of the subsequent filtrate, add the dissolution medium to make exactly V' mL so that each mL contains about 11 μg of carvedilol ($\text{C}_{24}\text{H}_{26}\text{N}_2\text{O}_4$), and use this solution as the sample solution. Separately, weigh accurately about 28 mg of carvedilol for assay, previously dried at 105°C for 2 hours, and dissolve in methanol to make exactly 50 mL. Pipet 2 mL of this solution, add the dissolution medium to make exactly 100 mL, and use this solution as the standard solution. Determine the absorbances, A_T and A_S , at 285 nm of the sample solution and standard solution as directed under Ultraviolet-visible Spectrophotometry <2.24>, using the dissolution medium as the blank.

$$\begin{aligned} &\text{Dissolution rate (\%)} \text{ with respect to the labeled amount} \\ &\text{of carvedilol (C}_{24}\text{H}_{26}\text{N}_2\text{O}_4) \\ &= M_S \times A_T/A_S \times V'/V \times 1/C \times 36 \end{aligned}$$

M_S : Amount (mg) of carvedilol for assay taken

C : Labeled amount (mg) of carvedilol ($\text{C}_{24}\text{H}_{26}\text{N}_2\text{O}_4$) in 1 tablet

(2) 1.25-mg tablet and 2.5-mg tablet When the test is performed at 50 revolutions per minute according to the Paddle method, using 900 mL of 0.05 mol/L acetic acid-sodium acetate buffer solution (pH 4.0) as the dissolution medium, the dissolution rate in 20 minutes is not less than 75%.

Start the test with 1 tablet of Carvedilol Tablets, withdraw not less than 20 mL of the medium at the specified minute after starting the test, and filter through a membrane filter with a pore size not exceeding 0.45 μm . Discard not less than 10 mL of the first filtrate, pipet V mL of the subsequent filtrate, add the dissolution medium to make exactly V' mL so that each mL contains about 1.4 μg of carvedilol ($\text{C}_{24}\text{H}_{26}\text{N}_2\text{O}_4$), and use this solution as the sample solution. Separately, weigh accurately about 28 mg of carvedilol for

assay, previously dried at 105°C for 2 hours, and dissolve in methanol to make exactly 200 mL. Pipet 2 mL of this solution, add the dissolution medium to make exactly 200 mL, and use this solution as the standard solution. Determine the absorbances, A_T and A_S , at 240 nm of the sample solution and standard solution as directed under Ultraviolet-visible Spectrophotometry <2.24>, using the dissolution medium as the blank.

$$\begin{aligned} &\text{Dissolution rate (\%)} \text{ with respect to the labeled amount} \\ &\text{of carvedilol (C}_{24}\text{H}_{26}\text{N}_2\text{O}_4) \\ &= M_S \times A_T/A_S \times V'/V \times 1/C \times 9/2 \end{aligned}$$

M_S : Amount (mg) of carvedilol for assay taken

C : Labeled amount (mg) of carvedilol ($\text{C}_{24}\text{H}_{26}\text{N}_2\text{O}_4$) in 1 tablet

Assay Weigh accurately the mass of not less than 20 Carvedilol Tablets, and powder. Weigh accurately a portion of the powder, equivalent to about 25 mg of carvedilol ($\text{C}_{24}\text{H}_{26}\text{N}_2\text{O}_4$), add exactly 5 mL of the internal standard solution, add a mixture of 0.1 mol/L hydrochloric acid TS and methanol (1:1) to make 250 mL, and shake for 30 minutes. To 2 mL of this solution, add the mobile phase to make 20 mL, and filter through a membrane filter with a pore size not exceeding 0.45 μm . Discard the first 10 mL of the filtrate, and use the subsequent filtrate as the sample solution. Separately, weigh accurately about 25 mg of carvedilol for assay, previously dried at 105°C for 2 hours, add exactly 5 mL of the internal standard solution, and add a mixture of 0.1 mol/L hydrochloric acid TS and methanol (1:1) to make 250 mL. To 2 mL of this solution add the mobile phase to make 20 mL, and use this solution as the standard solution. Perform the test with 10 μL each of the sample solution and standard solution as directed under Liquid Chromatography <2.01> under the following conditions, and calculate the ratios, Q_T and Q_S , of the peak area of carvedilol to that of the internal standard.

$$\begin{aligned} &\text{Amount (mg) of carvedilol (C}_{24}\text{H}_{26}\text{N}_2\text{O}_4) \\ &= M_S \times Q_T/Q_S \end{aligned}$$

M_S : Amount (mg) of carvedilol for assay taken

Internal standard solution—A solution of isoamyl parahydroxybenzoate in the mobile phase (1 in 70).

Operating conditions—

Detector: An ultraviolet absorption photometer (wavelength: 240 nm).

Column: A stainless steel column 4.6 mm in inside diameter and 15 cm in length, packed with octadecylsilanized silica gel for liquid chromatography (5 μm in particle diameter).

Column temperature: A constant temperature of about 40°C.

Mobile phase: Dissolve 2.7 g of potassium dihydrogen phosphate in water to make 1000 mL, and adjust to pH 5.0 with a solution prepared by dissolving 0.7 g of dipotassium hydrogen phosphate in water to make 200 mL. To 450 mL of this solution add 550 mL of methanol.

Flow rate: Adjust so that the retention time of carvedilol is about 5 minutes.

System suitability—

System performance: When the procedure is run with 10 μL of the standard solution under the above operating conditions, carvedilol and the internal standard are eluted in this order with the resolution between these peaks being not less than 20.

System repeatability: When the test is repeated 6 times with 10 μL of the standard solution under the above operating conditions, the relative standard deviation of the ratio of

the peak area of carvedilol to that of the internal standard is not more than 1.0%.

Containers and storage Containers—Tight containers.

Cefaclor

セファクロル

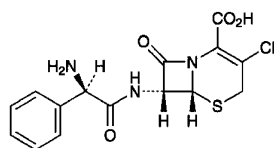

$C_{15}H_{14}ClN_3O_4S$: 367.81

(6*R*,7*R*)-7-[(2*R*)-2-Amino-2-phenylacetamino]-3-chloro-8-oxo-5-thia-1-azabicyclo[4.2.0]oct-2-ene-2-carboxylic acid
[53994-73-3]

Cefaclor contains not less than 950 μ g (potency) and not more than 1020 μ g (potency) per mg, calculated on the anhydrous basis. The potency of Cefaclor is expressed as mass (potency) of cefaclor ($C_{15}H_{14}ClN_3O_4S$).

Description Cefaclor occurs as a white to yellow-white crystalline powder.

It is slightly soluble in water and in methanol, and practically insoluble in *N,N*-dimethylformamide and in ethanol (99.5).

Identification (1) Determine the absorption spectrum of a solution of Cefaclor (1 in 50,000) as directed under Ultraviolet-visible Spectrophotometry <2.24>, and compare the spectrum with the Reference Spectrum: both spectra exhibit similar intensities of absorption at the same wavelengths.

(2) Determine the infrared absorption spectrum of Cefaclor as directed in the potassium bromide disk method under Infrared Spectrophotometry <2.25>, and compare the spectrum with the Reference Spectrum: both spectra exhibit similar intensities of absorption at the same wave numbers.

(3) Dissolve 40 mg of Cefaclor in 0.5 mL of heavy water for nuclear magnetic resonance spectroscopy and 1 drop of deuterated hydrochloric acid for nuclear magnetic resonance spectroscopy, and determine the 1H spectrum of this solution as directed under Nuclear Magnetic Resonance Spectroscopy <2.21>, using sodium 3-trimethylsilylpropanesulfonate for nuclear magnetic resonance spectroscopy as an internal reference compound: it exhibits an AB type quartet signal A at around δ 3.7 ppm, and a singlet signal or a sharp multiplet signal B at around δ 7.6 ppm. The ratio of the integrated intensity of each signal, A:B, is about 2:5.

(4) Perform the test with Cefaclor as directed under Flame Coloration Test <1.04> (2): a green color appears.

Optical rotation <2.49> $[\alpha]_D^{20}$: +105 – +120° (0.1 g calculated on the anhydrous basis, water, 25 mL, 100 mm).

Purity (1) Heavy metals <1.07>—Proceed with 1.0 g of Cefaclor according to Method 2, and perform the test. Prepare the control solution with 2.0 mL of Standard Lead Solution (not more than 20 ppm).

(2) Arsenic <1.11>—Prepare the test solution by suspending 1.0 g of Cefaclor in 10 mL of *N,N*-dimethylformamide, and perform the test (not more than 2 ppm).

(3) Related substances—Dissolve 50 mg of Cefaclor in 10 mL of sodium dihydrogen phosphate TS (pH 2.5), and use

this solution as the sample solution. Pipet 1 mL of the sample solution, add sodium dihydrogen phosphate TS (pH 2.5) to make exactly 100 mL, and use this solution as the standard solution. Perform the test with exactly 20 μ L each of the sample solution and standard solution as directed under Liquid Chromatography <2.01> according to the following conditions, and determine each peak area by the automatic integration method: the area of the peaks other than cefaclor obtained from the sample solution are not larger than 1/2 times the peak area of cefaclor from the standard solution, and the total area of the peaks other than cefaclor from the sample solution is not larger than 2 times of the peak area of cefaclor from the standard solution. If necessary, proceed with 20 μ L of sodium dihydrogen phosphate TS (pH 2.5) in the same manner as above to compensate the base line.

Operating conditions—

Detector: An ultraviolet absorption photometer (wavelength: 220 nm).

Column: A stainless steel column 4.6 mm in inside diameter and 25 cm in length, packed with octadecylsilanized silica gel for liquid chromatography (5 μ m in particle diameter).

Column temperature: A constant temperature of about 25°C.

Mobile phase A: Dissolve 7.8 g of sodium dihydrogen phosphate dihydrate in 1000 mL of water, and adjust the pH to 4.0 with phosphoric acid.

Mobile phase B: To 550 mL of the mobile phase A add 450 mL of acetonitrile for liquid chromatography.

Flowing of mobile phase: Control the gradient by mixing the mobile phases A and B as directed in the following table.

Time after injection of sample (min)	Mobile phase A (vol%)	Mobile phase B (vol%)
0 – 30	95 → 75	5 → 25
30 – 45	75 → 0	25 → 100
45 – 55	0	100

Flow rate: 1.0 mL per minute.

Time span of measurement: About 2.5 times as long as the retention time of cefaclor, beginning after the solvent peak.

System suitability—

Test for required detectability: Measure exactly 1 mL of the standard solution, and add sodium dihydrogen phosphate TS, pH 2.5 to make exactly 20 mL. Confirm that the peak area of cefaclor obtained with 20 μ L of this solution is equivalent to 4 to 6% of that with 20 μ L of the standard solution.

System performance: When the procedure is run with 20 μ L of the standard solution under the above operating conditions, the number of theoretical plates and the symmetry factor of the peak of cefaclor are not less than 40,000 and 0.8 to 1.3, respectively.

System repeatability: When the test is repeated 3 times with 20 μ L of the standard solution under the above operating conditions, the relative standard deviations of the peak areas and the retention times of cefaclor are not more than 2.0%, respectively.

Water <2.48> Not more than 6.5% (0.2 g, volumetric titration, back titration).

Assay Weigh accurately an amount of Cefaclor and Cefaclor RS, equivalent to about 50 mg (potency), and dissolve each in 0.1 mol/L phosphate buffer solution (pH 4.5) to make exactly 50 mL. Pipet 10 mL each of these solutions, add exactly 10 mL of the internal standard solution, add 0.1

mol/L phosphate buffer solution (pH 4.5) to make 50 mL, and use these solutions as the sample solution and the standard solution, respectively. Perform the test with 10 μ L each of the sample solution and standard solution as directed under Liquid Chromatography <2.01> according to the following conditions, and calculate the ratios, Q_T and Q_S , of the peak area of cefaclor to that of the internal standard.

$$\begin{aligned} \text{Amount } [\mu\text{g (potency)] of cefaclor } (C_{15}H_{14}ClN_3O_4S) \\ = M_S \times Q_T / Q_S \times 1000 \end{aligned}$$

M_S : Amount [mg (potency)] of Cefaclor RS taken

Internal standard solution—A solution of 4-aminoacetophenone in 0.1 mol/L phosphate buffer solution (pH 4.5) (1 in 700).

Operating conditions—

Detector: An ultraviolet absorption photometer (wavelength: 254 nm).

Column: A stainless steel column 4.6 mm in inside diameter and 15 cm in length, packed with octadecylsilanized silica gel for liquid chromatography (5 μ m in particle diameter).

Column temperature: A constant temperature of about 25°C.

Mobile phase: Dissolve 6.8 g of potassium dihydrogen phosphate in 1000 mL of water, and adjust the pH to 3.4 with diluted phosphoric acid (3 in 500). To 940 mL of this solution add 60 mL of acetonitrile.

Flow rate: Adjust so that the retention time of cefaclor is about 7 minutes.

System suitability—

System performance: When the procedure is run with 10 μ L of the standard solution under the above operating conditions, cefaclor and the internal standard are eluted in this order with the resolution between these peaks being not less than 5.

System repeatability: When the test is repeated 6 times with 10 μ L of the standard solution under the above operating conditions, the relative standard deviation of the ratios of the peak area of cefaclor to that of the internal standard is not more than 1.0%.

Containers and storage Containers—Tight containers.

Storage—Light-resistant.

Cefaclor Capsules

セファクロルカプセル

Cefaclor Capsules contain not less than 90.0% and not more than 110.0% of the labeled potency of cefaclor ($C_{15}H_{14}ClN_3O_4S$; 367.81).

Method of preparation Prepare as directed under Capsules, with Cefaclor.

Identification Shake vigorously a quantity of the contents of Cefaclor Capsules, equivalent to 20 mg (potency) of Cefaclor, with 10 mL of water, centrifuge, and use the supernatant liquid as the sample solution. Separately, dissolve 20 mg of Cefaclor RS in 10 mL of water, and use this solution as the standard solution. Perform the test with these solutions as directed under Thin-layer Chromatography <2.03>. Spot 2 μ L each of the sample solution and standard solution on a plate of silica gel with fluorescent indicator for thin-layer chromatography, develop the plate with a mixture of acetonitrile, water, ethyl acetate and formic acid (30:10:10:1) to a distance of about 10 cm, and air-dry the plate. Examine

under ultraviolet light (main wavelength: 254 nm): the principal spot obtained from the sample solution and the spot from the standard solution show the same R_f value.

Purity Related substances—Weigh accurately not less than 5 Cefaclor Capsules, open the capsules and carefully take out the contents, mix well, and powder, if necessary. Wash the empty capsules with a little amount of diethyl ether, if necessary, allow the capsules to stand at room temperature to vaporize adhering diethyl ether, and weigh accurately the capsules to calculate the mass of the contents. Weigh accurately a quantity of the contents, equivalent to about 0.25 g (potency) of Cefaclor, shake with 40 mL of 0.1 mol/L phosphate buffer solution (pH 4.5) for 10 minutes, add the same buffer solution to make exactly 50 mL, and filter through a 0.45- μ m pore-size membrane filter. Discard the first 1 mL of the filtrate, and use the subsequent filtrate as the sample solution. Separately, weigh accurately an amount of Cefaclor RS, equivalent to about 20 mg (potency), and dissolve in 0.1 mol/L phosphate buffer solution (pH 4.5) to make exactly 20 mL. Pipet 2.5 mL of this solution, add the same buffer solution to make exactly 50 mL, and use this solution as the standard solution. Perform the test with exactly 20 μ L each of the sample solution and standard solution as directed under Liquid Chromatography <2.01> according to the following conditions, and determine the peak areas by the automatic integration method. Calculate the amount of each related substance by the following equation: the amount of each related substance is not more than 0.5%, and the total amount of the related substances is not more than 2.5%. If necessary, correct the fluctuation of the base line by performing the test in the same manner with 20 μ L of 0.1 mol/L phosphate buffer solution (pH 4.5).

$$\begin{aligned} \text{Amount (\%)} \text{ of each related substance} \\ = M_S / M_T \times A_T / A_S \times M_M / C \times 25 / 2 \end{aligned}$$

$$\begin{aligned} \text{Total amount (\%)} \text{ of the related substances} \\ = M_S / M_T \times \Sigma A_T / A_S \times M_M / C \times 25 / 2 \end{aligned}$$

M_S : Amount [mg (potency)] of Cefaclor RS taken

M_T : Amount (mg) of the contents of Cefaclor Capsules taken

M_M : Average mass (mg) of the contents in 1 capsule

A_T : Area of each peak other than cefaclor and solvent from the sample solution

A_S : Peak area of cefaclor from the standard solution

C : Labeled potency [mg (potency)] of Cefaclor in 1 capsule

Operating conditions—

Proceed as directed in the operating conditions in the Purity (3) under Cefaclor.

System suitability—

Test for required detectability: Pipet 1 mL of the standard solution, and add 0.1 mol/L phosphate buffer solution (pH 4.5) to make exactly 20 mL. Confirm that the peak area of cefaclor obtained with 20 μ L of this solution is equivalent to 3.5 to 6.5% of that with 20 μ L of the standard solution.

System performance: When the procedure is run with 20 μ L of the standard solution under the above operating conditions, the number of theoretical plates and the symmetry factor of the peak of cefaclor are not less than 40,000 and 0.8 to 1.3, respectively.

System repeatability: When the test is repeated 3 times with 20 μ L of the standard solution under the above operating conditions, the relative standard deviation of the peak area of cefaclor is not more than 2.0%.

Water <2.48> Not more than 8.0% (0.2 g, volumetric titra-

tion, back titration).

Uniformity of dosage units <6.02> It meets the requirement of the Mass variation test.

Dissolution <6.10> When the test is performed at 50 revolutions per minute according to the Paddle method, using 900 mL of water as the dissolution medium, the dissolution rate in 15 minutes of Cefaclor Capsules is not less than 80%.

Start the test with 1 capsule of Cefaclor Capsules, withdraw not less than 20 mL of the medium at the specified minute after starting the test, and filter through a membrane filter with a pore size not exceeding 0.5 μm . Discard not less than 10 mL of the first filtrate, pipet V mL of the subsequent filtrate, add water to make exactly V' mL so that each mL contains about 20 μg (potency) of Cefaclor, and use this solution as the sample solution. Separately, weigh accurately about 20 mg (potency) of Cefaclor RS, and dissolve in water to make exactly 20 mL. Pipet 1 mL of this solution, add water to make exactly 50 mL, and use this solution as the standard solution. Determine the absorbances, A_T and A_S , at 265 nm of the sample solution and standard solution as directed under Ultraviolet-visible Spectrophotometry <2.24>.

Dissolution rate (%) with respect to the labeled amount of cefaclor ($\text{C}_{15}\text{H}_{14}\text{ClN}_3\text{O}_4\text{S}$)

$$= M_S \times A_T / A_S \times V' / V \times 1 / C \times 90$$

M_S : Amount [mg (potency)] of Cefaclor RS taken

C : Labeled amount [mg (potency)] of Cefaclor in 1 capsule

Assay Weigh accurately not less than 5 Cefaclor Capsules, open the capsules and carefully take out the contents, mix well, and powder, if necessary. Wash the empty capsules with a little amount of diethyl ether, if necessary, allow the capsules to stand at room temperature to vaporize adhering diethyl ether, and weigh accurately the capsules to calculate the mass of the contents. Weigh accurately a quantity of the contents, equivalent to about 0.1 g (potency) of Cefaclor, shake vigorously with 60 mL of 0.1 mol/L phosphate buffer solution (pH 4.5) for 10 minutes, add the same buffer solution to make exactly 100 mL, and centrifuge. Pipet 10 mL of the supernatant liquid, add exactly 10 mL of the internal standard solution and the same buffer solution to make 50 mL, and use this solution as the sample solution. Separately, weigh accurately an amount of Cefaclor RS, equivalent to about 50 mg (potency), and dissolve in 0.1 mol/L phosphate buffer solution (pH 4.5) to make exactly 50 mL. Pipet 10 mL of this solution, add exactly 10 mL of the internal standard solution and the same buffer solution to make 50 mL, and use this solution as the standard solution. Proceed as directed in the Assay under Cefaclor.

Amount [mg (potency)] of cefaclor ($\text{C}_{15}\text{H}_{14}\text{ClN}_3\text{O}_4\text{S}$)

$$= M_S \times Q_T / Q_S \times 2$$

M_S : Amount [mg (potency)] of Cefaclor RS taken

Internal standard solution—A solution of 4-aminoacetophenone in 0.1 mol/L phosphate buffer solution (pH 4.5) (1 in 700).

Containers and storage Containers—Tight containers.

Storage—Light-resistant.

Cefaclor Combination Granules

セファクロル複合顆粒

Cefaclor Combination Granules contain gastric-soluble granules and enteric-soluble granules in one package.

It contains cefaclor ($\text{C}_{15}\text{H}_{14}\text{ClN}_3\text{O}_4\text{S}$: 367.81) equivalent to not less than 90.0% and not more than 110.0% of the labeled total potency and the labeled potency of gastric-soluble granule, respectively.

Method of preparation Prepare as directed under Granules, with Cefaclor, and divide into single-dose packages.

Identification Shake vigorously a quantity of Cefaclor Combination Granules, equivalent to 20 mg (potency) of Cefaclor according to the labeled total potency, with 10 mL of water, centrifuge, and use the supernatant liquid as the sample solution. Separately, dissolve 20 mg of Cefaclor RS in 10 mL of water, and use this solution as the standard solution. Perform the test with these solutions as directed under Thin-layer Chromatography <2.03>. Spot 2 μL each of the sample solution and standard solution on a plate of silica gel with fluorescent indicator for thin-layer chromatography, develop the plate with a mixture of acetonitrile, water, ethyl acetate and formic acid (30:10:10:1) to a distance of about 10 cm, and air-dry the plate. Examine under ultraviolet light (main wavelength: 254 nm): the principal spot obtained from the sample solution and the spot from the standard solution show the same R_f value.

Purity Related substances—Take out the total content of not less than 5 packages of Cefaclor Combination Granules, add a small amount of 0.1 mol/L phosphate buffer solution (pH 4.5), grind, add 0.1 mol/L phosphate buffer solution (pH 4.5), shake vigorously for 10 minutes, and add 0.1 mol/L phosphate buffer solution (pH 4.5) to make exactly V mL so that each mL contains about 5 mg (potency) of Cefaclor according to the labeled total potency. Pipet 10 mL of this solution, add 0.1 mol/L phosphate buffer solution (pH 4.5) to make exactly 25 mL, and filter through a membrane filter with a pore size not exceeding 0.45 μm . Discard the first 1 mL of the filtrate, and use the subsequent filtrate as the sample solution. Separately, weigh accurately an amount of Cefaclor RS, equivalent to about 20 mg (potency), and dissolve in 0.1 mol/L phosphate buffer solution (pH 4.5) to make exactly 20 mL. Pipet 2 mL of this solution, add 0.1 mol/L phosphate buffer solution (pH 4.5) to make exactly 100 mL, and use this solution as the standard solution. Perform the test with exactly 50 μL each of the sample solution and standard solution as directed under Liquid Chromatography <2.01> according to the following conditions, and determine each peak area in each solution by the automatic integration method. Calculate the amount of each related substance by the following equation: the amount of each related substance is not more than 0.6%, and the total amount of the related substances is not more than 2.8%. If necessary, correct the fluctuation of the base line by performing the test in the same manner with 50 μL of 0.1 mol/L phosphate buffer solution (pH 4.5).

Amount (%) of each related substance

$$= M_S \times A_T / A_S \times V / 4 \times \{1 / (C \times T)\}$$

Total amount (%) of the related substances

$$= M_S \times \Sigma A_T / A_S \times V / 4 \times \{1 / (C \times T)\}$$

- M_S : Amount [mg (potency)] of Cefaclor RS taken
 A_T : Area of each peak other than cefaclor, solvent and excipient from the sample solution
 ΣA_T : Total area of the peaks other than cefaclor, solvent and excipient from the sample solution
 A_S : Peak area of cefaclor from the standard solution
 C : Labeled total potency [mg (potency)] of Cefaclor in 1 package
 T : Number (pack) of Cefaclor Combination Granules

Operating conditions—

Proceed as directed in the operating conditions in the Purity (3) under Cefaclor.

System suitability—

Test for required detectability: Pipet 1 mL of standard solution, and add 0.1 mol/L phosphate buffer solution (pH 4.5) to make exactly 20 mL. Confirm that the peak area of cefaclor obtained from 50 μ L of this solution is equivalent to 3.5 to 6.5% of that obtained from 50 μ L of the standard solution.

System performance: When the procedure is run with 50 μ L of the standard solution under the above operating conditions, the number of theoretical plates and the symmetry factor of the peak of cefaclor are not less than 40,000 and between 0.8 and 1.3, respectively.

System repeatability: When the test is repeated 3 times with 50 μ L of the standard solution under the above operating conditions, the relative standard deviation of the peak area of cefaclor is not more than 2.0%.

Water <2.48> Not more than 5.5% (0.3 g, volumetric titration, back titration).

Uniformity of dosage units <6.02> Perform the test according to the following method: it meets the requirement of the Content uniformity test.

(1) Total potency—Take out the total content of 1 package of Cefaclor Combination Granules, add a little amount of 0.1 mol/L phosphate buffer solution (pH 4.5), grind well, add the same buffer solutions to make exactly V mL so that each mL contains about 3.8 mg (potency) of Cefaclor according to the labeled total potency after shaking vigorously for 10 minutes, and centrifuge. Pipet 3 mL of the supernatant liquid, add exactly 10 mL of the internal standard solution and the same buffer solution to make 50 mL, and use this solution as the sample solution. Separately, weigh accurately an amount of Cefaclor RS, equivalent to about 50 mg (potency), and dissolve in 0.1 mol/L phosphate buffer solution (pH 4.5) to make exactly 50 mL. Pipet 10 mL of this solution, add exactly 10 mL of the internal standard solution and the same buffer solution to make 50 mL, and use this solution as the standard solution. Then, proceed as directed in the Assay under Cefaclor.

$$\begin{aligned} &\text{Amount [mg (potency)] of cefaclor (C}_{15}\text{H}_{14}\text{ClN}_3\text{O}_4\text{S)} \\ &= M_S \times Q_T/Q_S \times V/15 \end{aligned}$$

M_S : Amount [mg (potency)] of Cefaclor RS taken

Internal standard solution—A solution of 4-aminoacetophenone in 0.1 mol/L phosphate buffer solution (pH 4.5) (1 in 700).

(2) Potency of gastric-soluble granule—Take out the total content of 1 package of Cefaclor Combination Granules stir gently with 60 mL of 0.1 mol/L phosphate buffer solution (pH 4.5) for 5 minutes, add the same buffer solution to make exactly V mL so that each mL contains about 1.5 mg (potency) of Cefaclor according to the labeled potency of gastric-soluble granule, and centrifuge. Pipet 7 mL of the supernatant liquid, add exactly 10 mL of the internal

standard solution and the same buffer solution to make 50 mL, and use this solution as the sample solution. Separately, weigh accurately an amount of Cefaclor RS, equivalent to about 50 mg (potency), and dissolve in 0.1 mol/L phosphate buffer solution (pH 4.5) to make exactly 50 mL. Pipet 10 mL of this solution, add exactly 10 mL of the internal standard solution and the same buffer solution to make 50 mL, and use this solution as the standard solution. Then, proceed as directed in the Assay under Cefaclor.

$$\begin{aligned} &\text{Amount [mg (potency)] of cefaclor (C}_{15}\text{H}_{14}\text{ClN}_3\text{O}_4\text{S)} \\ &= M_S \times Q_T/Q_S \times V/35 \end{aligned}$$

M_S : Amount [mg (potency)] of Cefaclor RS taken

Internal standard solution—A solution of 4-aminoacetophenone in 0.1 mol/L phosphate buffer solution (pH 4.5) (1 in 700).

Dissolution <6.10> When the test is performed at 50 revolutions per minute according to the Paddle method, using 900 mL of 1st fluid for dissolution test as the dissolution medium, the dissolution rate in 60 minutes of Cefaclor Combination Granules is between 35% and 45%.

Start the test with the total content of 1 package of Cefaclor Combination Granules, withdraw not less than 20 mL of the medium at the specified minute after starting the test, and filter through a membrane filter with a pore size not exceeding 0.5 μ m. Discard not less than 10 mL of the first filtrate, pipet V mL of the subsequent filtrate, add the dissolution medium to make exactly V' mL so that each mL contains about 20 μ g (potency) of Cefaclor according to the labeled potency of gastric-soluble granule, and use this solution as the sample solution. Separately, weigh accurately an amount of Cefaclor RS, equivalent to about 20 mg (potency), and dissolve in the dissolution medium to make exactly 20 mL. Pipet 2 mL of this solution, add the dissolution medium to make exactly 100 mL, and use this solution as the standard solution. Determine the absorbances, A_T and A_S , at 265 nm of the sample solution and standard solution as directed under Ultraviolet-visible Spectrophotometry <2.24>.

$$\begin{aligned} &\text{Dissolution rate (\%)} \text{ of cefaclor (C}_{15}\text{H}_{14}\text{ClN}_3\text{O}_4\text{S)} \text{ with} \\ &\text{respect to the labeled potency} \\ &= M_S \times A_T/A_S \times V'/V \times 1/C \times 90 \end{aligned}$$

M_S : Amount [mg (potency)] of Cefaclor RS taken

C : Labeled total potency [mg (potency)] of Cefaclor in 1 pack

Separately, when the test is performed at 50 revolutions per minute according to the Paddle method, using 900 mL of 2nd fluid for dissolution test as the dissolution medium, the dissolution rate in 60 minutes of Cefaclor Combination Granules is not less than 70%.

Start the test with the total content of 1 package of Cefaclor Combination Granules, withdraw not less than 20 mL of the medium at the specified minute after starting the test, and filter through a membrane filter with a pore size not exceeding 0.5 μ m. Discard not less than 10 mL of the first filtrate, pipet V mL of the subsequent filtrate, add 0.01 mol/L hydrochloric acid TS to make exactly V' mL so that each mL contains about 20 μ g (potency) of Cefaclor according to the labeled total potency, and use this solution as the sample solution. Separately, weigh accurately an amount of Cefaclor RS, equivalent to about 20 mg (potency), dissolve in the dissolution medium to make exactly 100 mL, and warm at 37°C for 60 minutes. Pipet 2 mL of this solution, add 0.01 mol/L hydrochloric acid TS to make exactly 20 mL, and use this solution as the standard solution. Deter-

mine the absorbances, A_T and A_S , at 265 nm of the sample solution and standard solution as directed under Ultraviolet-visible Spectrophotometry <2.24>, using 0.01 mol/L hydrochloric acid TS as the blank.

Dissolution rate (%) of cefaclor ($C_{15}H_{14}ClN_3O_4S$) with respect to the labeled potency

$$= M_S \times A_T/A_S \times V'/V \times 1/C \times 90$$

M_S : Amount [mg (potency)] of Cefaclor RS taken
 C: Labeled total potency [mg (potency)] of Cefaclor in 1 package

Assay (1) Total potency—Take out the total content of not less than 5 Cefaclor Combination Granules, add a small amount of 0.1 mol/L phosphate buffer solution (pH 4.5), grind well, add the same buffer solution so that each mL containing about 5 mg (potency) of Cefaclor according to the labeled total potency after shaking vigorously for 10 minutes, and centrifuge. Pipet 2 mL of the supernatant liquid, add exactly 10 mL of the internal standard solution and the same buffer solution to make 50 mL, and use this solution as the sample solution. Separately, weigh accurately an amount of Cefaclor RS, equivalent to about 50 mg (potency), and dissolve in 0.1 mol/L phosphate buffer solution (pH 4.5) to make exactly 50 mL. Pipet 10 mL of this solution, add exactly 10 mL of the internal standard solution and the same buffer solution to make 50 mL, and use this solution as the standard solution. Then, proceed as directed in the Assay under Cefaclor.

Amount [mg (potency)] of cefaclor ($C_{15}H_{14}ClN_3O_4S$)

$$= M_S \times Q_T/Q_S \times 1/5$$

M_S : Amount [mg (potency)] of Cefaclor RS taken

Internal standard solution—A solution of 4-aminoacetophenone in 0.1 mol/L phosphate buffer solution (pH 4.5) (1 in 700).

(2) Potency of gastric-soluble granule—Stir gently the total content of not less than 5 Cefaclor Combination Granules with about 100 mL of 0.1 mol/L phosphate buffer solution (pH 4.5) for 5 minutes, add the same buffer solution so that each mL containing about 2 mg (potency) of Cefaclor according to the labeled potency of gastric-soluble granule, and centrifuge. Pipet 5 mL of the supernatant liquid, add exactly 10 mL of the internal standard solution and the same buffer solution to make 50 mL, and use this solution as the sample solution. Separately, weigh accurately an amount of Cefaclor RS, equivalent to about 50 mg (potency), and dissolve in 0.1 mol/L phosphate buffer solution (pH 4.5) to make exactly 50 mL. Pipet 10 mL of this solution, add exactly 10 mL of the internal standard solution and the same buffer solution to make 50 mL, and use this solution as the standard solution. Then, proceed as directed in the Assay under Cefaclor.

Amount [mg (potency)] of cefaclor ($C_{15}H_{14}ClN_3O_4S$)

$$= M_S \times Q_T/Q_S \times 1/5$$

M_S : Amount [mg (potency)] of Cefaclor RS taken

Internal standard solution—A solution of 4-aminoacetophenone in 0.1 mol/L phosphate buffer solution (pH 4.5) (1 in 700).

Containers and storage Containers—Tight containers.
 Storage—Light-resistant.

Cefaclor Fine Granules

セファクロル細粒

Cefaclor Fine Granules contain not less than 90.0% and not more than 110.0% of the labeled potency of cefaclor ($C_{15}H_{14}ClN_3O_4S$; 367.81).

Method of preparation Prepare as directed under Granules, with Cefaclor.

Identification Shake vigorously a quantity of Cefaclor Fine Granules, equivalent to 20 mg (potency) of Cefaclor, with 10 mL of water, centrifuge, and use the supernatant liquid as the sample solution. Separately, dissolve 20 mg (potency) of Cefaclor RS in 10 mL of water, and use this solution as the standard solution. Perform the test with these solutions as directed under Thin-layer Chromatography <2.03>. Spot 2 μ L each of the sample solution and standard solution on a plate of silica gel with fluorescent indicator for thin-layer chromatography, develop the plate with a mixture of acetonitrile, water, ethyl acetate and formic acid (30:10:10:1) to a distance of about 10 cm, and air-dry the plate. Examine under ultraviolet light (main wavelength: 254 nm): the principal spot from the sample solution and the spot from the standard solution show the same R_f value.

Purity Related substances—Weigh accurately a quantity of Cefaclor Fine Granules after powdered if necessary, equivalent to about 0.1 g (potency) of Cefaclor, shake with 40 mL of 0.1 mol/L phosphate buffer solution (pH 4.5) for 10 minutes, add the same buffer solution to make exactly 50 mL, and filter through a 0.45- μ m pore-size membrane filter. Discard the first 1 mL of the filtrate, and use the subsequent filtrate as the sample solution. Separately, weigh accurately an amount of Cefaclor RS, equivalent to about 20 mg (potency), and dissolve in 0.1 mol/L phosphate buffer solution (pH 4.5) to make exactly 20 mL. Pipet 2 mL of this solution, add the same buffer solution to make exactly 100 mL, and use this solution as the standard solution. Perform the test with exactly 50 μ L each of the sample solution and standard solution as directed under Liquid Chromatography <2.01> according to the following conditions, and determine the peak areas by the automatic integration method. Calculate the amount of each related substance by the following equation: the amount of each related substance is not more than 0.5%, and the total amount of the related substances is not more than 3.0%. If necessary, correct the fluctuation of the base line by performing the test in the same manner with 50 μ L of 0.1 mol/L phosphate buffer solution (pH 4.5).

Amount (%) of each related substance

$$= M_S/M_T \times A_T/A_S \times 1/C \times 5$$

Total amount (%) of the related substances

$$= M_S/M_T \times \Sigma A_T/A_S \times 1/C \times 5$$

M_S : Amount [mg (potency)] of Cefaclor RS taken

M_T : Amount (g) of Cefaclor Fine Granules taken

A_T : Area of the peak other than cefaclor and the solvent from the sample solution

A_S : Peak area of cefaclor from the standard solution

C: Labeled potency [mg (potency)] of cefaclor ($C_{15}H_{14}ClN_3O_4S$) in 1 g

Operating conditions—

Proceed as directed in the operating conditions in the Purity (3) under Cefaclor.

System suitability—

Test for required detectability: Pipet 1 mL of the standard solution, and add 0.1 mol/L phosphate buffer solution (pH 4.5) to make exactly 20 mL. Confirm that the peak area of cefaclor obtained with 50 μ L of this solution is equivalent to 3.5 to 6.5% of that with 50 μ L of the standard solution.

System performance: When the procedure is run with 50 μ L of the standard solution under the above operating conditions, the number of theoretical plates and the symmetry factor of the peak of cefaclor are not less than 40,000 and between 0.8 and 1.3, respectively.

System repeatability: When the test is repeated 3 times with 50 μ L of the standard solution under the above operating conditions, the relative standard deviation of the peak area of cefaclor is not more than 2.0%.

Water <2.48> Not more than 1.5% (1 g, volumetric titration, back titration).

Uniformity of dosage units <6.02> The granules in single-dose packages meet the requirement of the Mass variation test.

Dissolution <6.10> When the test is performed at 50 revolutions per minute according to the Paddle method, using 900 mL of water as the dissolution medium, the dissolution rate in 15 minutes of Cefaclor Fine Granules is not less than 85%.

Start the test with an accurately weighed amount of Cefaclor Fine Granules, equivalent to about 0.25 g (potency) of Cefaclor, withdraw not less than about 20 mL of the medium at the specified minute after starting the test, and filter through a membrane filter with a pore size not exceeding 0.5 μ m. Discard not less than 10 mL of the first filtrate, pipet V mL of the subsequent filtrate, add water to make exactly V' mL so that each mL contains about 20 μ g (potency) of Cefaclor, and use this solution as the sample solution. Separately, weigh accurately about 20 mg (potency) of Cefaclor RS, and dissolve in water to make exactly 20 mL. Pipet 1 mL of this solution, add water to make exactly 50 mL, and use this solution as the standard solution. Determine the absorbances, A_T and A_S , at 265 nm of the sample solution and standard solution as directed under Ultraviolet-visible Spectrophotometry <2.24>.

Dissolution rate (%) with respect to the labeled amount of cefaclor ($C_{15}H_{14}ClN_3O_4S$)

$$= M_S/M_T \times A_T/A_S \times V'/V \times 1/C \times 90$$

M_S : Amount [mg (potency)] of Cefaclor RS taken

M_T : Amount [mg (potency)] of Cefaclor Fine Granules taken

C : Labeled amount [mg (potency)] of cefaclor ($C_{15}H_{14}ClN_3O_4S$) in 1 g

Assay Weigh accurately a quantity of Cefaclor Fine Granules after powdered if necessary, equivalent to about 0.1 g (potency) of Cefaclor, shake vigorously with 60 mL of 0.1 mol/L phosphate buffer solution (pH 4.5) for 10 minutes, add the same buffer solution to make exactly 100 mL, and centrifuge. Pipet 10 mL of the supernatant liquid, add exactly 10 mL of the internal standard solution and the same buffer solution to make 50 mL, and use this solution as the sample solution. Separately, weigh accurately about 50 mg (potency) of Cefaclor RS, and dissolve in 0.1 mol/L phosphate buffer solution (pH 4.5) to make exactly 50 mL. Pipet 10 mL of this solution, add exactly 10 mL of the internal standard solution and the same buffer solution to make 50 mL, and use this solution as standard solution. Proceed as directed in the Assay under Cefaclor.

$$\text{Amount [mg (potency)] of cefaclor } (C_{15}H_{14}ClN_3O_4S) \\ = M_S \times Q_T/Q_S \times 2$$

M_S : Amount [mg (potency)] of Cefaclor RS taken

Internal standard solution—A solution of 4-aminoacetophenone in 0.1 mol/L phosphate buffer solution (pH 4.5) (1 in 700).

Containers and storage Containers—Tight containers.

Storage—Light-resistant.

Cefadroxil

セファドロキシル

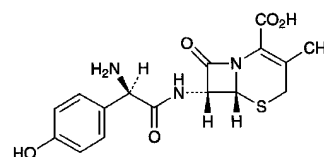

$C_{16}H_{17}N_3O_5S$: 363.39

(6*R*,7*R*)-7-[(2*R*)-2-Amino-2-(4-hydroxyphenyl)acetyl-amino]-3-methyl-8-oxo-5-thia-1-azabicyclo[4.2.0]oct-2-ene-2-carboxylic acid
[50370-12-2]

Cefadroxil contains not less than 950 μ g (potency) and not more than 1020 μ g (potency) per mg, calculated on the anhydrous basis. The potency of Cefadroxil is expressed as mass (potency) of cefadroxil ($C_{16}H_{17}N_3O_5S$).

Description Cefadroxil occurs as a white to light yellow-white powder.

It is sparingly soluble in water, slightly soluble in methanol, and very slightly soluble in ethanol (95).

Identification (1) Determine the absorption spectrum of a solution of Cefadroxil (1 in 50,000) as directed under Ultraviolet-visible Spectrophotometry <2.24>, and compare the spectrum with the Reference Spectrum or the spectrum of a solution of Cefadroxil RS prepared in the same manner as the sample solution: both spectra exhibit similar intensities of absorption at the same wavelengths.

(2) Determine the infrared absorption spectrum of Cefadroxil as directed in the potassium bromide disk method under Infrared Spectrophotometry <2.25>, and compare the spectrum with the Reference Spectrum or the spectrum of Cefadroxil RS: both spectra exhibit similar intensities of absorption at the same wave numbers.

(3) Determine the 1H spectrum of a solution of Cefadroxil in a mixture of heavy water for nuclear magnetic resonance spectroscopy and deuterated hydrochloric acid (3:1) (1 in 10), using sodium 3-(trimethylsilyl)propionate- d_4 for nuclear magnetic resonance spectroscopy as an internal reference compound, as directed under Nuclear Magnetic Resonance Spectroscopy <2.21>: it exhibits a singlet signal A at around δ 2.1 ppm, a doublet signal B at around δ 7.0 ppm, and a doublet signal C at around δ 7.5 ppm. The ratio of integrated intensity of each signal, A:B:C, is about 3:2:2.

Optical rotation <2.49> $[\alpha]_D^{25}$: +164 – +182° (0.6 g calculated on the anhydrous basis, water, 100 mL, 100 mm).

pH <2.54> Dissolve 1.0 g of Cefadroxil in 200 mL of water: pH of the solution is between 4.0 and 6.0.

Purity (1) Heavy metals <1.07>—Proceed with 1.0 g of

Cefadroxil according to Method 2, and perform the test. Prepare the control solution with 2.0 mL of Standard Lead Solution (not more than 20 ppm).

(2) Related substances—Dissolve 0.1 g of Cefadroxil in 4 mL of a mixture of ethanol (99.5), water and diluted hydrochloric acid (1 in 5) (75:22:3), and use this solution as the sample solution. Pipet 1 mL of the sample solution, add a mixture of ethanol (99.5), water and diluted hydrochloric acid (1 in 5) (75:22:3) to make exactly 100 mL, and use this solution as the standard solution. Perform the test with these solutions as directed under Thin-layer Chromatography <2.03>. Spot 2 μ L each of the sample solution and standard solution on a plate of silica gel for thin-layer chromatography. Develop with a mixture of ethyl acetate, water, ethanol (99.5) and formic acid (14:5:5:1) to a distance of about 12 cm, and air-dry the plate. Spray evenly ninhydrin-citric acid-acetic acid TS on the plate, and heat the plate at 100°C for 10 minutes: the spots other than the principal spot obtained from the sample solution are not more intense than the spot from the standard solution.

Water <2.48> Not less than 4.2% and not more than 6.0% (0.5 g, volumetric titration, direct titration).

Assay Weigh accurately an amount of Cefadroxil and Cefadroxil RS, equivalent to about 50 mg (potency), dissolve each in water to make exactly 500 mL, and use these solutions as the sample solution and the standard solution, respectively. Perform the test with exactly 10 μ L each of the sample solution and standard solution as directed under Liquid Chromatography <2.01> according to the following conditions, and determine the peak areas, A_T and A_S , of cefadroxil in each solution.

$$\begin{aligned} &\text{Amount } [\mu\text{g (potency)}] \text{ of cefadroxil (C}_{16}\text{H}_{17}\text{N}_3\text{O}_5\text{S)} \\ &= M_S \times A_T/A_S \times 1000 \end{aligned}$$

M_S : amount [mg (potency)] of Cefadroxil RS taken

Operating conditions—

Detector: An ultraviolet absorption photometer (wavelength: 262 nm).

Column: A stainless steel column 4.6 mm in inside diameter and 25 cm in length, packed with octadecylsilanized silica gel for liquid chromatography (5 μ m in particle diameter).

Column temperature: A constant temperature of about 40°C.

Mobile phase: A mixture of a solution of potassium dihydrogenphosphate (17 in 12,500) and methanol (17:3).

Flow rate: Adjust so that the retention time of cefadroxil is about 5 minutes.

System suitability—

System performance: Dissolve about 5 mg (potency) of Cefadroxil and about 10 mg (potency) of propylene glycol cefatrizine in 50 mL of water. When the procedure is run with 10 μ L of this solution under the above operating conditions, cefadroxil and cefatrizine are eluted in this order with the resolution between these peaks being not less than 4.

System repeatability: When the test is repeated 6 times with 10 μ L of the standard solution under the above operating conditions, the relative standard deviation of the peak areas of cefadroxil is not more than 1.0%.

Containers and storage Containers—Tight containers.

Cefadroxil Capsules

セファドロキシルカプセル

Cefadroxil Capsules contain not less than 95.0% and not more than 105.0% of the labeled potency of cefadroxil (C₁₆H₁₇N₃O₅S: 363.39).

Method of preparation Prepare as directed under Capsules, with Cefadroxil.

Identification Dissolve the contents of Cefadroxil Capsules, equivalent to 10 mg (potency) of Cefadroxil, in 500 mL of water, and filter. Determine the absorption spectrum of the filtrate as directed under Ultraviolet-visible Spectrophotometry <2.24>: it exhibits maxima between 228 nm and 232 nm, and between 261 nm and 265 nm.

Water <2.48> Not more than 7.0% (0.15 g, volumetric titration, direct titration).

Uniformity of dosage units <6.02> Perform the test according to the following method: it meets the requirement of the Content uniformity test.

Place 1 capsule of Cefadroxil Capsules in 300 mL of water, disperse with the aid of ultrasonic waves, shake for 30 minutes, and add water to make exactly 500 mL. Pipet 5 mL of this solution, and add water to make exactly V mL so that each mL contains about 0.1 mg (potency) of Cefadroxil. Filter the solution, discard the first 10 mL of the filtrate, and use the subsequent filtrate as the sample solution. Separately, weigh accurately about 20 mg (potency) of Cefadroxil RS, dissolve in water to make exactly 200 mL, and use this solution as the standard solution. Then, proceed as directed in the Assay under Cefadroxil.

$$\begin{aligned} &\text{Amount [mg (potency)] of cefadroxil (C}_{16}\text{H}_{17}\text{N}_3\text{O}_5\text{S)} \\ &= M_S \times A_T/A_S \times V/2 \end{aligned}$$

M_S : Amount [mg (potency)] of Cefadroxil RS taken

Dissolution <6.10> When the test is performed at 50 revolutions per minute according to the Paddle method, using 900 mL of 0.05 mol/L acetic acid-sodium acetate buffer solution (pH 4.0) as the dissolution medium, the dissolution rate in 90 minutes of Cefadroxil Capsules is not less than 80%.

Start the test with 1 capsule of Cefadroxil Capsules, withdraw not less than 20 mL of the medium at the specified minute after starting the test, and filter through a membrane filter with a pore size not exceeding 0.45 μ m. Discard not less than 10 mL of the first filtrate, pipet V mL of the subsequent filtrate, add water to make exactly V' mL so that each mL contains about 22 μ g (potency) of Cefadroxil, and use this solution as the sample solution. Separately, weigh accurately about 22 mg (potency) of Cefadroxil RS, and add water to make exactly 100 mL. Pipet 5 mL of this solution, add water to make exactly 50 mL, and use this solution as the standard solution. Determine the absorbances, A_T and A_S , at 263 nm of the sample solution and standard solution as directed under Ultraviolet-visible Spectrophotometry <2.24>, using water as the blank.

$$\begin{aligned} &\text{Dissolution rate (\%)} \text{ with respect to the labeled amount} \\ &\text{of cefadroxil (C}_{16}\text{H}_{17}\text{N}_3\text{O}_5\text{S)} \\ &= M_S \times A_T/A_S \times V'/V \times 1/C \times 90 \end{aligned}$$

M_S : Amount [mg (potency)] of Cefadroxil RS taken

C : Labeled amount [mg (potency)] of cefadroxil in 1 capsule

Assay Take out the contents of 20 Cefadroxil Capsules, and combine. Weigh accurately the mass of the combined contents, and powder. Weigh accurately a portion of the powder, equivalent to about 50 mg (potency) of Cefadroxil, add 300 mL of water, shake for 30 minutes, then add water to make exactly 500 mL, and filter. Discard the first 10 mL of the filtrate, and use the subsequent filtrate as the sample solution. Separately, weigh accurately an amount of Cefadroxil RS, equivalent to about 20 mg (potency), dissolve in water to make exactly 200 mL, and use this solution as the standard solution. Then, proceed as directed in the Assay under Cefadroxil.

$$\begin{aligned} & \text{Amount [mg (potency)] of cefadroxil (C}_{16}\text{H}_{17}\text{N}_3\text{O}_5\text{S)} \\ & = M_S \times A_T/A_S \times 5/2 \end{aligned}$$

M_S : Amount [mg (potency)] of Cefadroxil RS taken

Containers and storage Containers—Tight containers.

Cefadroxil for Syrup

シロップ用セファドロキシル

Cefadroxil for Syrup is a preparation for syrup, which is suspended before use.

It contains not less than 95.0% and not more than 110.0% of the labeled potency of cefadroxil (C₁₆H₁₇N₃O₅S: 363.39).

Method of preparation Prepare as directed under Preparations for Syrups, with Cefadroxil.

Identification Dissolve an amount of Cefadroxil for Syrup, equivalent to 10 mg (potency) of Cefadroxil, in 500 mL of water, and determine the absorption spectrum of this solution as directed under Ultraviolet-visible Spectrophotometry <2.24>: it exhibits maxima between 228 nm and 232 nm, and between 261 nm and 265 nm.

Water <2.48> Not more than 3.0% (0.5 g, volumetric titration, direct titration).

Uniformity of dosage units <6.02> The syrup in single-dose packages meets the requirement of the Mass variation test.

Dissolution <6.10> When the test is performed at 50 revolutions per minute according to the Paddle method (put the sample in the dissolution medium so that it disperses), using 900 mL of water as the dissolution medium, the dissolution rate in 15 minutes of Cefadroxil for Syrup is not less than 85%.

Start the test with accurately weighed amount of Cefadroxil for Syrup, equivalent to about 0.1 g (potency) of Cefadroxil, withdraw not less than 20 mL of the medium at the specified minute after starting the test, and filter through a membrane filter with a pore size not exceeding 0.45 μm. Discard not less than 10 mL of the first filtrate, pipet 4 mL of the subsequent filtrate, add water to make exactly 20 mL, and use this solution as the sample solution. Separately, weigh accurately about 22 mg (potency) of Cefadroxil RS, and dissolve in water to make exactly 100 mL. Pipet 5 mL of this solution, add water to make exactly 50 mL, and use this solution as the standard solution. Determine the absorbances, A_T and A_S , at 263 nm of the sample solution and standard solution as directed under Ultraviolet-visible Spectrophotometry <2.24>.

Dissolution rate (%) with respect to the labeled amount of cefadroxil (C₁₆H₁₇N₃O₅S)

$$= M_S/M_T \times A_T/A_S \times 1/C \times 450$$

M_S : Amount [mg (potency)] of Cefadroxil RS taken

M_T : Amount (g) of Cefadroxil for Syrup taken

C : Labeled amount [mg (potency)] of cefadroxil in 1 g

Assay Weigh accurately an amount of powdered Cefadroxil for Syrup, equivalent to about 50 mg (potency) of Cefadroxil, dissolve in water to make exactly 500 mL, and use this solution as the sample solution. Separately, weigh accurately an amount of Cefadroxil RS, equivalent to about 20 mg (potency), dissolve in water to make exactly 200 mL, and use this solution as the standard solution. Then, proceed as directed in the Assay under Cefadroxil.

$$\text{Amount [mg (potency)] of cefadroxil (C}_{16}\text{H}_{17}\text{N}_3\text{O}_5\text{S)} = M_S \times A_T/A_S \times 5/2$$

M_S : Amount [mg (potency)] of Cefadroxil RS taken

Containers and storage Containers—Tight containers.

Cefalexin

セファレキシン

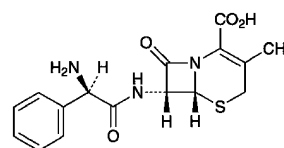

C₁₆H₁₇N₃O₄S: 347.39

(6*R*,7*R*)-7-[(2*R*)-2-Amino-2-phenylacetyl-amino]-3-methyl-8-oxo-5-thia-1-azabicyclo[4.2.0]oct-2-ene-2-carboxylic acid

[15686-71-2]

Cefalexin contains not less than 950 μg (potency) and not more than 1030 μg (potency) per mg, calculated on the anhydrous basis. The potency of Cefalexin is expressed as mass (potency) of cefalexin (C₁₆H₁₇N₃O₄S).

Description Cefalexin occurs as a white to light yellow-white, crystals or crystalline powder.

It is sparingly soluble in water, slightly soluble in methanol, and practically insoluble in ethanol (95) and in *N,N*-dimethylformamide.

It is hygroscopic.

Identification (1) Determine the absorption spectrum of a solution of Cefalexin (3 in 100,000) as directed under Ultraviolet-visible Spectrophotometry <2.24>, and compare the spectrum with the Reference Spectrum: both spectra exhibit similar intensities of absorption at the same wavelengths.

(2) Determine the infrared absorption spectrum of Cefalexin as directed in the potassium bromide disk method under Infrared Spectrophotometry <2.25>, and compare the spectrum with the Reference Spectrum: both spectra exhibit similar intensities of absorption at the same wave numbers.

(3) Determine the ¹H spectrum of a solution of Cefalexin in heavy water for nuclear magnetic resonance spectroscopy (1 in 200) as directed under Nuclear Magnetic Resonance Spectroscopy <2.21>, using sodium 3-trimethylsilylpropane-sulfonate for nuclear magnetic resonance spectroscopy as an internal reference compound: it exhibits a singlet signal A at around δ 1.8 ppm, and a singlet or a sharp multiplet signal B

at around δ 7.5 ppm. The ratio of integrated intensity of these signals, A:B, is about 3:5.

Optical rotation <2.49> $[\alpha]_D^{20}$: +144 – +158° (0.125 g calculated on the anhydrous basis, water, 25 mL, 100 mm).

Purity (1) Heavy metals <1.07>—Proceed with 2.0 g of Cefalexin according to Method 4, and perform the test. Prepare the control solution with 2.0 mL of Standard Lead Solution (not more than 10 ppm).

(2) **Arsenic** <1.11>—Prepare the test solution with 1.0 g of Cefalexin by suspending in 10 mL of *N,N*-dimethylformamide, and perform the test (not more than 2 ppm).

(3) **Related substances**—Dissolve about 25 mg of Cefalexin in a solution of potassium dihydrogenphosphate (9 in 500) to make 5 mL, and use this solution as the sample solution. Pipet 1 mL of the sample solution, add a solution of potassium dihydrogenphosphate (9 in 500) to make exactly 100 mL, and use this solution as the standard solution. Perform the test with exactly 20 μ L each of the sample solution and standard solution as directed under Liquid Chromatography <2.01> according to the following conditions, and determine the areas of each peak by the automatic integration method. If necessary, correct the change of the base-line due to the potassium dihydrogenphosphate solution by proceeding in the same manner with 20 μ L of a solution of potassium dihydrogenphosphate (9 in 500): each peak area other than cefalexin from the sample solution is not larger than the peak area of cefalexin from the standard solution, and the total area of the peaks other than cefalexin from the sample solution which are larger than 1/50 times the peak area of cefalexin from the standard solution is not larger than 5 times of the peak area of cefalexin from the standard solution.

Operating conditions—

Detector: An ultraviolet absorption photometer (wavelength: 254 nm).

Column: A stainless steel column 4.6 mm in inside diameter and 25 cm in length, packed with octadecylsilanized silica gel for liquid chromatography (5 μ m in particle diameter).

Column temperature: A constant temperature of about 25°C.

Mobile phase A: Dissolve 1.0 g of sodium 1-pentanesulfonate in 1000 mL of water, add 15 mL of triethylamine, and adjust to pH 2.5 with phosphoric acid.

Mobile phase B: Dissolve 1.0 g of sodium 1-pentanesulfonate in 300 mL of water, add 15 mL of triethylamine, and adjust to pH 2.5 with phosphoric acid. To this solution add 350 mL of acetonitrile and 350 mL of methanol.

Flowing of mobile phase: Control the gradient by mixing the mobile phases A and B as directed in the following table.

Time after injection of sample (min)	Mobile phase A (vol%)	Mobile phase B (vol%)
0 – 1	100	0
1 – 34.5	100 → 0	0 → 100
34.5 – 35.5	0	100

Flow rate: 1.0 mL per minute.

Time span of measurement: About 2 times as long as the retention time of cefalexin, beginning after the solvent peak.

System suitability—

Test for required detectability: Pipet 2 mL of the standard solution, add a solution of potassium dihydrogenphosphate (9 in 500) to make exactly 100 mL. Confirm that the peak area of cefalexin obtained with 20 μ L of this solution is

equivalent to 1.8 to 2.2% of that with 20 μ L of the standard solution.

System performance: When the procedure is run with 20 μ L of the standard solution under the above operating conditions, the number of theoretical plates and the symmetry factor of the peak of cefalexin are not less than 150,000 and between 0.8 and 1.3, respectively.

System repeatability: When the test is repeated 3 times with 20 μ L of the standard solution under the above operating conditions, the relative standard deviation of the retention time and the peak areas of cefalexin are not more than 2.0%, respectively.

Water <2.48> Not more than 8.0% (0.2 g, volumetric titration, back titration).

Assay Weigh accurately an amount of Cefalexin and Cefalexin RS, equivalent to about 25 mg (potency), dissolve each in 0.1 mol/L phosphate buffer solution (pH 4.5) to make exactly 25 mL. Pipet 10 mL of these solutions, add exactly 5 mL of the internal standard solution, then add 0.1 mol/L phosphate buffer solution (pH 4.5) to make 50 mL, and use these solutions as the sample solution and standard solution. Perform the test with 10 μ L each of the sample solution and standard solution as directed under Liquid Chromatography <2.01> according to the following conditions, and calculate the ratios, Q_T and Q_S , of the peak area of cefalexin to that of the internal standard.

$$\begin{aligned} \text{Amount } [\mu\text{g (potency)}] \text{ of cefalexin (C}_{16}\text{H}_{17}\text{N}_3\text{O}_4\text{S)} \\ = M_S \times Q_T/Q_S \times 1000 \end{aligned}$$

M_S : amount [mg (potency)] of Cefalexin RS taken

Internal standard solution—A solution of *m*-hydroxyacetophenone in 0.1 mol/L phosphate buffer solution (pH 4.5) (1 in 1500).

Operating conditions—

Detector: An ultraviolet absorption photometer (wavelength: 254 nm).

Column: A stainless steel column 4.6 mm in inside diameter and 15 cm in length, packed with octadecylsilanized silica gel for liquid chromatography (5 μ m in particle diameter).

Column temperature: A constant temperature of about 25°C.

Mobile phase: Dissolve 6.8 g of potassium dihydrogenphosphate in 1000 mL of water, adjust to pH 3.0 with diluted phosphoric acid (3 in 500). To 800 mL of this solution add 200 mL of methanol.

Flow rate: Adjust so that the retention time of cefalexin is about 7 minutes.

System suitability—

System performance: When the procedure is run with 10 μ L of the standard solution under the above operating conditions, cefalexin and the internal standard are eluted in this order with the resolution between these peaks being not less than 6.

System repeatability: When the test is repeated 5 times with 10 μ L of the standard solution under the above operating conditions, the relative standard deviation of the ratios of the peak area of cefalexin to that of the internal standard is not more than 1.0%.

Containers and storage Containers—Tight containers.

Cefalexin Capsules

セファレキシнкаプセル

Cefalexin Capsules contain not less than 93.0% and not more than 107.0% of the labeled potency of cefalexin ($C_{16}H_{17}N_3O_4S$; 347.39).

Method of preparation Prepare as directed under Capsules, with Cefalexin.

Identification Take out the contents of Cefalexin Capsules, to a quantity of the contents, equivalent to 70 mg (potency) of Cefalexin, add 25 mL of water, shake vigorously for 5 minutes, and filter. To 1 mL of the filtrate add water to make 100 mL. Determine the absorption spectrum of this solution as directed under Ultraviolet-visible Spectrophotometry <2.24>: it exhibits a maximum between 260 nm and 264 nm.

Water <2.48> Not more than 10.0% (0.2 g, volumetric titration, back titration).

Uniformity of dosage units <6.02> Perform the Mass variation test, or the Content uniformity test according to the following method: it meets the requirement.

Open 1 capsule of Cefalexin Capsules, add 3*V*/5 mL of 0.1 mol/L phosphate buffer solution (pH 4.5), shake vigorously for 10 minutes, add 0.1 mol/L phosphate buffer solution (pH 4.5) to make exactly *V* mL so that each mL contains about 1.25 mg (potency) of Cefalexin. Centrifuge this solution, pipet 2 mL of the supernatant liquid, add exactly 10 mL of the internal standard solution, add 0.1 mol/L phosphate buffer solution (pH 4.5) to make 100 mL, and use this solution as the sample solution. Separately, weigh accurately an amount of Cefalexin RS, equivalent to about 25 mg (potency), dissolve in 0.1 mol/L phosphate buffer solution (pH 4.5) to make exactly 100 mL. Pipet 10 mL of this solution, add exactly 10 mL of the internal standard solution, add 0.1 mol/L phosphate buffer solution (pH 4.5) to make 100 mL, and use this solution as the standard solution. Perform the test with 10 μ L each of the sample solution and standard solution as directed under Liquid Chromatography <2.01> according to the following conditions, and calculate the ratios, Q_T and Q_S , of the peak area of cefalexin to that of the internal standard.

$$\begin{aligned} & \text{Amount [mg (potency)] of cefalexin } (C_{16}H_{17}N_3O_4S) \\ & = M_S \times Q_T/Q_S \times V/20 \end{aligned}$$

M_S : Amount [mg (potency)] of Cefalexin RS taken

Internal standard solution—A solution of *m*-hydroxycetophenone in 0.1 mol/L phosphate buffer solution (pH 4.5) (1 in 15,000).

Operating conditions—

Proceed as directed in the operating conditions in the Assay.

System suitability—

System performance: When the procedure is run with 10 μ L of the standard solution under the above operating conditions, cefalexin and the internal standard are eluted in this order with the resolution between these peaks being not less than 8.

System repeatability: When the test is repeated 6 times with 10 μ L of the standard solution under the above operating conditions, the relative standard deviation of the ratio of the peak area of cefalexin to that of the internal standard substance is not more than 1.0%.

Dissolution <6.10> When the test is performed at 50 revolutions per minute according to the Paddle method, using 900 mL of water as the dissolution medium, the dissolution rates in 30 minutes of 125-mg (potency) capsule and in 60 minutes of 250-mg (potency) capsule are not less than 75% and 80%, respectively.

Start the test with 1 capsule of Cefalexin Capsules, withdraw not less than 20 mL of the medium at the specified minute after starting the test, and filter through a membrane filter with a pore size not exceeding 0.5 μ m. Discard not less than 10 mL of the first filtrate, pipet *V* mL of the subsequent filtrate, add water to make exactly *V'* mL so that each mL contains about 22 μ g (potency) of Cefalexin, and use this solution as the sample solution. Separately, weigh accurately an amount of Cefalexin RS, equivalent to about 22 mg (potency), and dissolve in water to make exactly 50 mL. Pipet 5 mL of this solution, add water to make exactly 100 mL, and use this solution as the standard solution. Perform the test with the sample solution and standard solution as directed under Ultraviolet-visible Spectrophotometry <2.24>, and determine the absorbances, A_T and A_S , at 262 nm.

Dissolution rate (%) with respect to the labeled amount of cefalexin ($C_{16}H_{17}N_3O_4S$)

$$= M_S \times A_T/A_S \times V'/V \times 1/C \times 90$$

M_S : Amount [mg (potency)] of Cefalexin RS taken

C : Labeled amount [mg (potency)] of cefalexin ($C_{16}H_{17}N_3O_4S$) in 1 capsule

Assay Take out the contents of not less than 20 capsules of Cefalexin Capsules, weigh accurately the mass of the contents, and powder. Weigh accurately a portion of the powder, equivalent to about 0.1 g (potency) of Cefalexin, add 60 mL of 0.1 mol/L phosphate buffer solution (pH 4.5), shake vigorously for 10 minutes, add 0.1 mol/L phosphate buffer solution (pH 4.5) to make exactly 100 mL, and centrifuge. Pipet 2 mL of the supernatant liquid, add exactly 10 mL of the internal standard solution, add 0.1 mol/L phosphate buffer solution (pH 4.5) to make 100 mL, and use this solution as the sample solution. Separately, weigh accurately an amount of Cefalexin RS, equivalent to about 20 mg (potency), dissolve in 0.1 mol/L phosphate buffer solution (pH 4.5) to make exactly 100 mL. Pipet 10 mL of this solution, add exactly 10 mL of the internal standard solution, add 0.1 mol/L phosphate buffer solution (pH 4.5) to make 100 mL, and use this solution as the standard solution. Perform the test with 10 μ L each of the sample solution and standard solution as directed under Liquid Chromatography <2.01> according to the following conditions, and calculate the ratios, Q_T and Q_S , of the peak area of cefalexin to that of the internal standard.

$$\begin{aligned} & \text{Amount [mg (potency)] of cefalexin } (C_{16}H_{17}N_3O_4S) \\ & = M_S \times Q_T/Q_S \times 5 \end{aligned}$$

M_S : Amount [mg (potency)] of Cefalexin RS taken

Internal standard solution—A solution of *m*-hydroxycetophenone in 0.1 mol/L phosphate buffer solution (pH 4.5) (1 in 15,000).

Operating conditions—

Detector: An ultraviolet absorption photometer (wavelength: 254 nm).

Column: A stainless steel column 3.0 mm in inside diameter and 7.5 cm in length, packed with octadecylsilanized silica gel for liquid chromatography (3 μ m in particle diameter).

Column temperature: A constant temperature of about 25°C.

Mobile phase: Dissolve 2.72 g of potassium dihydrogen phosphate in 1000 mL of water, and adjust the pH to 3.0 with diluted phosphoric acid (3 in 500). To 800 mL of this solution add 200 mL of methanol.

Flow rate: Adjust so that the retention time of cefalexin is about 6 minutes.

System suitability—

System performance: When the procedure is run with 10 μ L of the standard solution under the above operating conditions, cefalexin and the internal standard are eluted in this order with the resolution between these peaks being not less than 8.

System repeatability: When the test is repeated 6 times with 10 μ L of the standard solution under the above operating conditions, the relative standard deviation of the ratio of the peak area of cefalexin to that of the internal standard is not more than 1.0%.

Containers and storage Containers—Tight containers.

Cefalexin Combination Granules

セファレキシン複合顆粒

Cefalexin Combination Granules contain gastric-soluble granules and enteric-soluble granules in one package.

It contains not less than 90.0% and not more than 110.0% of cefalexin ($C_{16}H_{17}N_3O_4S$; 347.39) for the labeled total potency and the labeled potency of gastric-soluble granules, respectively.

Method of preparation Prepare as directed under Granules, with Cefalexin, and pack into single-dose packages.

Identification Powder Cefalexin Combination Granules, weigh a portion of the powder, equivalent to 30 mg (potency) of Cefalexin according to the labeled total potency, shake vigorously for 5 minutes with 100 mL of water, and centrifuge. To 2 mL of the supernatant liquid add water to make 20 mL. Determine the absorption spectrum of this solution as directed under Ultraviolet-visible Spectrophotometry <2.24>: it exhibits a maximum between 260 nm and 264 nm.

Water <2.48> Not more than 5.0% (0.5 g, volumetric titration, direct titration).

Uniformity of dosage units <6.02> Perform the test according to the following method: it meets the requirement of the Content uniformity test.

(1) Total potency—To the total content of 1 package of Cefalexin Combination Granules add a small amount of 0.1 mol/L phosphate buffer solution (pH 4.5), grind, add 3 $V/5$ mL of 0.1 mol/L phosphate buffer solution (pH 4.5), shake vigorously for 10 minutes, add 0.1 mol/L phosphate buffer solution (pH 4.5) to make exactly V mL so that each mL contains about 2 mg (potency) of Cefalexin according to the labeled total potency, and centrifuge. Pipet 2 mL of the supernatant liquid, add exactly 20 mL of the internal standard solution, add 0.1 mol/L phosphate buffer solution (pH 4.5) to make 200 mL, and use this solution as the sample solution. Then, proceed as directed in the Assay (1) Total potency.

$$\begin{aligned} &\text{Amount [mg (potency)] of cefalexin } (C_{16}H_{17}N_3O_4S) \\ &= M_S \times Q_T/Q_S \times V/10 \end{aligned}$$

M_S : Amount [mg (potency)] of Cefalexin RS taken

Internal standard solution—A solution of *m*-hydroxyacetophenone in 0.1 mol/L phosphate buffer solution (pH 4.5) (1 in 15,000).

(2) Potency of gastric-soluble granules—To the total content of 1 package of Cefalexin Combination Granules, add 3 $V/5$ mL of 0.1 mol/L phosphate buffer solution (pH 4.5), shake gently for 5 minutes, add 0.1 mol/L phosphate buffer solution (pH 4.5) to make exactly V mL so that each mL contains about 0.6 mg (potency) of Cefalexin according to the labeled potency of gastric-soluble granules, and centrifuge. Pipet 7 mL of the supernatant liquid, add exactly 20 mL of the internal standard solution, add 0.1 mol/L phosphate buffer solution (pH 4.5) to make 200 mL, and use this solution as the sample solution. Then, proceed as directed in the Assay (1) Total potency.

$$\begin{aligned} &\text{Amount [mg (potency)] of cefalexin } (C_{16}H_{17}N_3O_4S) \\ &= M_S \times Q_T/Q_S \times V/35 \end{aligned}$$

M_S : Amount [mg (potency)] of Cefalexin RS taken

Internal standard solution—A solution of *m*-hydroxyacetophenone in 0.1 mol/L phosphate buffer solution (pH 4.5) (1 in 15,000).

Dissolution <6.10> When the test is performed at 50 revolutions per minute according to the Paddle method, using 900 mL of 1st fluid for dissolution test as the dissolution medium, the dissolution rate in 30 minutes of Cefalexin Combination Granules is between 25% and 35%.

Start the test with the total content of 1 package of Cefalexin Combination Granules, withdraw not less than 20 mL of the medium at the specified minute after starting the test, and filter through a membrane filter with a pore size not exceeding 0.5 μ m. Discard not less than 10 mL of the first filtrate, pipet V mL of the subsequent filtrate, add the dissolution medium to make exactly V' mL so that each mL contains about 22 μ g (potency) of Cefalexin according to the labeled potency of gastric-soluble granules, and use this solution as the sample solution. Separately, weigh accurately an amount of Cefalexin RS, equivalent to about 22 mg (potency), and dissolve in the dissolution medium to make exactly 50 mL. Pipet 5 mL of this solution, add the dissolution medium to make exactly 100 mL, and use this solution as the standard solution. Determine the absorbances, A_T and A_S , at 262 nm of the sample solution and standard solution as directed under Ultraviolet-visible Spectrophotometry <2.24>.

$$\begin{aligned} &\text{Dissolution rate (\%)} \text{ of cefalexin } (C_{16}H_{17}N_3O_4S) \\ &\text{with respect to the labeled potency} \\ &= M_S \times A_T/A_S \times V'/V \times 1/C \times 90 \end{aligned}$$

M_S : Amount [mg (potency)] of Cefalexin RS taken

C : Labeled total potency [mg (potency)] of Cefalexin in 1 package

When the test is performed at 50 revolutions per minute according to the Paddle method, using 900 mL of 2nd fluid for dissolution test as the dissolution medium, the dissolution rate in 60 minutes of 200 mg (potency) preparation is not less than 80%, and the dissolution rate in 45 minutes of 500 mg (potency) preparation is not less than 75%.

Start the test with the total content of 1 package of Cefalexin Combination Granules, withdraw not less than 20 mL of the medium at the specified minute after starting the test, and filter through a membrane filter with a pore size not exceeding 0.5 μ m. Discard not less than 10 mL of the first filtrate, pipet V mL of the subsequent filtrate, add the dissolution medium to make exactly V' mL so that each mL contains about 22 μ g (potency) of Cefalexin according to the

labeled total potency, and use this solution as the sample solution. Separately, weigh accurately an amount of Cefalexin RS, equivalent to about 22 mg (potency), dissolve in the dissolution medium to make exactly 50 mL. Pipet 5 mL of this solution, add the dissolution medium to make exactly 100 mL, and use this solution as the standard solution. Determine the absorbances, A_T and A_S , at 262 nm of the sample solution and standard solution as directed under Ultraviolet-visible Spectrophotometry <2.24>.

Dissolution rate (%) of cefalexin ($C_{16}H_{17}N_3O_4S$) with respect to the labeled potency

$$= M_S \times A_T/A_S \times V'/V \times 1/C \times 90$$

M_S : Amount [mg (potency)] of Cefalexin RS taken
 C : Labeled total potency [mg (potency)] of Cefalexin in 1 package

Assay (1) Total potency—Powder the total content obtained from not less than 20 packages of Cefalexin Combination Granules, weigh accurately a portion of the powder, equivalent to about 0.5 g (potency) of Cefalexin, shake vigorously for 10 minutes with 150 mL of 0.1 mol/L phosphate buffer solution (pH 4.5), add 0.1 mol/L phosphate buffer solution (pH 4.5) to make exactly 250 mL, and centrifuge. Pipet 2 mL of this solution, add exactly 20 mL of the internal standard solution, and add 0.1 mol/L phosphate buffer solution (pH 4.5) to make 200 mL, and use this solution as the sample solution. Separately, weigh accurately an amount of Cefalexin RS, equivalent to about 20 mg (potency), and dissolve in 0.1 mol/L phosphate buffer solution (pH 4.5) to make exactly 100 mL. Pipet 10 mL of this solution, add exactly 10 mL of the internal standard solution, and add 0.1 mol/L phosphate buffer solution (pH 4.5) to make 100 mL, and use this solution as the standard solution. Perform the test with 10 μ L each of the sample solution and standard solution as directed under Liquid Chromatography <2.01> according to the following conditions, and calculate the ratios, Q_T and Q_S , of the peak area of cefalexin to that of the internal standard.

Amount [mg (potency)] of cefalexin ($C_{16}H_{17}N_3O_4S$)

$$= M_S \times Q_T/Q_S \times 25$$

M_S : Amount [mg (potency)] of Cefalexin RS taken

Internal standard solution—A solution of *m*-hydroxyacetophenone in 0.1 mol/L phosphate buffer solution (pH 4.5) (1 in 15,000).

Operating conditions—

Detector: An ultraviolet absorption photometer (wavelength: 254 nm).

Column: A stainless steel column 3.0 mm in inside diameter and 7.5 cm in length, packed with octadecylsilanized silica gel for liquid chromatography (3 μ m in particle diameter).

Column temperature: A constant temperature of about 25°C.

Mobile phase: Dissolve 2.72 g of potassium dihydrogen phosphate in 1000 mL of water, and adjust to pH 3.0 with diluted phosphoric acid (3 in 500). To 800 mL of this solution add 200 mL of methanol.

Flow rate: Adjust so that the retention time of cefalexin is about 6 minutes.

System suitability—

System performance: When the procedure is run with 10 μ L of the standard solution under the above operating conditions, cefalexin and the internal standard are eluted in this order with the resolution between these peaks being not less than 8.

System repeatability: When the test is repeated 6 times with 10 μ L of the standard solution under the above operating conditions, the relative standard deviation of the ratio of the peak area of cefalexin to that of the internal standard is not more than 1.0%.

(2) Potency of gastric-soluble granules—Take out the content from not less than 20 packages of Cefalexin Combination Granules, weigh accurately a quantity, equivalent to about 0.3 g (potency) of Cefalexin according to the labeled potency of gastric-soluble granules, shake gently for 5 minutes with 200 mL of 0.1 mol/L phosphate buffer solution (pH 4.5), add 0.1 mol/L phosphate buffer solution (pH 4.5) to make exactly 300 mL, and centrifuge. Pipet 2 mL of the supernatant liquid, add exactly 10 mL of the internal standard solution, and add 0.1 mol/L phosphate buffer solution (pH 4.5) to make 100 mL, and use this solution as the sample solution. Then, proceed as directed in the Assay (1) Total potency.

Amount [mg (potency)] of cefalexin ($C_{16}H_{17}N_3O_4S$)

$$= M_S \times Q_T/Q_S \times 15$$

M_S : Amount [mg (potency)] of Cefalexin RS taken

Internal standard solution—A solution of *m*-hydroxyacetophenone in 0.1 mol/L phosphate buffer solution (pH 4.5) (1 in 15,000).

Containers and storage Containers—Tight containers.

Cefalexin for Syrup

シロップ用セファレキシン

Cefalexin for Syrup is a preparation for syrup, which is dissolved or suspended before use.

It contains not less than 90.0% and not more than 110.0% of the labeled potency of cefalexin ($C_{16}H_{17}N_3O_4S$: 347.39).

Method of preparation Prepare as directed under Preparations for Syrups, with Cefalexin.

Identification Dissolve a quantity of Cefalexin for Syrup, equivalent to 3 mg (potency) of Cefalexin, in water to make 100 mL. Determine the absorption spectrum of this solution as directed under Ultraviolet-visible Spectrophotometry <2.24>: it exhibits a maximum between 260 nm and 264 nm.

Water <2.48> Not more than 5.0% (0.4 g, volumetric titration, back titration).

Uniformity of dosage units <6.02> Perform the test according to the following method: Cefalexin for Syrup in single-dose packages meets the requirement of the Content uniformity test.

Take out the total content of 1 package of Cefalexin for Syrup, add 3V/5 mL of 0.1 mol/L phosphate buffer solution (pH 4.5), shake vigorously for 10 minutes, add 0.1 mol/L phosphate buffer solution (pH 4.5) to make exactly V mL so that each mL contains about 1 mg (potency) of Cefalexin, and centrifuge. Pipet 2 mL of the supernatant liquid, add exactly 10 mL of the internal standard solution, add 0.1 mol/L phosphate buffer solution (pH 4.5) to make 100 mL, and use this solution as the sample solution. Then, proceed as directed in the Assay.

Amount [mg (potency)] of cefalexin ($C_{16}H_{17}N_3O_4S$)

$$= M_S \times Q_T/Q_S \times V/20$$

M_S : Amount [mg (potency)] of Cefalexin RS taken

Internal standard solution—A solution of *m*-hydroxyacetophenone in 0.1 mol/L phosphate buffer solution (pH 4.5) (1 in 15,000).

Dissolution <6.10> When the test is performed at 50 revolutions per minute according to the Paddle method, using 900 mL of water as the dissolution medium, the dissolution rate in 15 minutes of Cefalexin for Syrup is not less than 80%.

Start the test with an accurately weighed amount of Cefalexin, equivalent to about 0.25 g (potency) of Cefalexin for Syrup, withdraw not less than 20 mL of the medium at the specified minute after starting the test, and filter through a membrane filter with a pore size not exceeding 0.5 μm . Discard not less than 10 mL of the first filtrate, pipet 2 mL of the subsequent filtrate, add water to make exactly 25 mL, and use this solution as the sample solution. Separately, weigh accurately an amount of Cefalexin RS, equivalent to about 22 mg (potency), and dissolve in water to make exactly 50 mL. Pipet 5 mL of this solution, add water to make exactly 100 mL, and use this solution as the standard solution. Perform the test with the sample solution and standard solution as directed under Ultraviolet-visible Spectrophotometry <2.24>, and determine the absorbances, A_T and A_S , at 262 nm.

Dissolution rate (%) with respect to the labeled amount of cefalexin ($\text{C}_{16}\text{H}_{17}\text{N}_3\text{O}_4\text{S}$)

$$= M_S/M_T \times A_T/A_S \times 1/C \times 1125$$

M_S : Amount [mg (potency)] of Cefalexin RS taken

M_T : Amount (g) of Cefalexin for Syrup taken

C : Labeled amount [mg (potency)] of cefalexin ($\text{C}_{16}\text{H}_{17}\text{N}_3\text{O}_4\text{S}$) in 1 g

Assay Powder Cefalexin for Syrup, if necessary, and weigh accurately a portion of the powder, equivalent to about 0.1 g (potency) of Cefalexin, add 60 mL of 0.1 mol/L phosphate buffer solution (pH 4.5), shake vigorously for 10 minutes, add 0.1 mol/L phosphate buffer solution (pH 4.5) to make exactly 100 mL, and centrifuge. Pipet 2 mL of the supernatant liquid, add exactly 10 mL of the internal standard solution, add 0.1 mol/L phosphate buffer solution (pH 4.5) to make 100 mL, and use this solution as the sample solution. Separately, weigh accurately an amount of Cefalexin RS, equivalent to about 20 mg (potency), dissolve in 0.1 mol/L phosphate buffer solution (pH 4.5) to make exactly 100 mL. Pipet 10 mL of this solution, add exactly 10 mL of the internal standard solution, add 0.1 mol/L phosphate buffer solution (pH 4.5) to make 100 mL, and use this solution as the standard solution. Perform the test with 10 μL each of the sample solution and standard solution as directed under Liquid Chromatography <2.01> according to the following conditions, and calculate the ratios, Q_T and Q_S , of the peak area of cefalexin to that of the internal standard.

Amount [mg (potency)] of cefalexin ($\text{C}_{16}\text{H}_{17}\text{N}_3\text{O}_4\text{S}$)

$$= M_S \times Q_T/Q_S \times 5$$

M_S : Amount [mg (potency)] of Cefalexin RS taken

Internal standard solution—A solution of *m*-hydroxyacetophenone in 0.1 mol/L phosphate buffer solution (pH 4.5) (1 in 15,000).

Operating conditions—

Detector: An ultraviolet absorption photometer (wavelength: 254 nm).

Column: A stainless steel column 3.0 mm in inside diameter and 7.5 cm in length, packed with octadecylsilanized silica gel for liquid chromatography (3 μm in particle diame-

ter).

Column temperature: A constant temperature of about 25°C.

Mobile phase: Dissolve 2.72 g of potassium dihydrogen phosphate in 1000 mL of water, and adjust the pH to 3.0 with diluted phosphoric acid (3 in 500). To 800 mL of this solution add 200 mL of methanol.

Flow rate: Adjust so that the retention time of cefalexin is about 6 minutes.

System suitability—

System performance: When the procedure is run with 10 μL of the standard solution under the above operating conditions, cefalexin and the internal standard are eluted in this order with the resolution between these peaks being not less than 8.

System repeatability: When the test is repeated 6 times with 10 μL of the standard solution under the above operating conditions, the relative standard deviation of the ratio of the peak area of cefalexin to that of the internal standard is not more than 1.0%.

Containers and storage Containers—Tight containers.

Storage—Light-resistant.

Cefalotin Sodium

セファロチンナトリウム

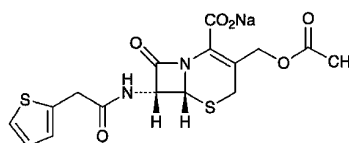

$\text{C}_{16}\text{H}_{15}\text{N}_2\text{NaO}_6\text{S}_2$: 418.42

Monosodium (6*R*,7*R*)-3-acetoxymethyl-8-oxo-7-[2-(thiophen-2-yl)acetylamino]-5-thia-1-azabicyclo[4.2.0]oct-2-ene-2-carboxylate
[58-71-9]

Cefalotin Sodium contains not less than 920 μg (potency) and not more than 980 μg (potency) per mg, calculated on the anhydrous basis. The potency of Cefalotin Sodium is expressed as mass (potency) of cefalotin ($\text{C}_{16}\text{H}_{16}\text{N}_2\text{O}_6\text{S}_2$: 396.44).

Description Cefalotin Sodium occurs as white to light yellow-white, crystals or crystalline powder.

It is freely soluble in water, slightly soluble in methanol, very slightly soluble in ethanol (95), and practically insoluble in acetonitrile.

Identification (1) Determine the absorption spectrum of a solution of Cefalotin Sodium (1 in 50,000) as directed under Ultraviolet-visible Spectrophotometry <2.24>, and compare the spectrum with the Reference Spectrum or the spectrum of a solution of Cefalotin Sodium RS prepared in the same manner as the sample solution: both spectra exhibit similar intensities of absorption at the same wavelengths.

(2) Determine the infrared absorption spectrum of Cefalotin Sodium as directed in the potassium bromide disk method under Infrared Spectrophotometry <2.25>, and compare the spectrum with the Reference Spectrum or the spectrum of Cefalotin Sodium RS: both spectra exhibit similar intensities of absorption at the same wave numbers.

(3) Determine the ^1H spectrum of a solution of Cefalotin Sodium in heavy water for nuclear magnetic resonance spectroscopy (1 in 10) as directed under Nuclear Magnetic

Resonance Spectroscopy <2.21>, using sodium 3-trimethylsilylpropanesulfonate for nuclear magnetic resonance spectroscopy as an internal reference compound: it exhibits a singlet signal A at around δ 2.1 ppm, a singlet or sharp multiplet signal B at around δ 3.9 ppm, and a multiplet signal C at around δ 7.0 ppm. The ratio of the integrated intensity of these signals, A:B:C, is about 3:2:2.

(4) Cefalotin Sodium responds to Qualitative Tests <1.09> (1) for sodium salt.

Optical rotation <2.49> $[\alpha]_D^{25}$: +124 – +134° (5 g, water, 100 mL, 100 mm).

pH <2.54> The pH of a solution obtained by dissolving 1.0 g of Cefalotin Sodium in 10 mL of water is between 4.5 and 7.0.

Purity (1) Clarity and color of solution—Dissolve 1.0 g of Cefalotin Sodium in 10 mL of water: the solution is clear. The absorbance of this solution at 450 nm, determined as directed under Ultraviolet-visible Spectrophotometry <2.24>, is not more than 0.20.

(2) Heavy metals <1.07>—Proceed with 1.0 g of Cefalotin Sodium according to Method 2, and perform the test. Prepare the control solution with 2.0 mL of Standard Lead Solution (not more than 20 ppm).

(3) Arsenic <1.11>—Prepare the test solution with 1.0 g of Cefalotin Sodium according to Method 3, and perform the test (not more than 2 ppm).

(4) Related substances—Pipet 1 mL of the standard solution obtained in the Assay, add the mobile phase to make exactly 100 mL, and use this solution as the standard solution. Perform the test with exactly 10 μ L each of the sample solution obtained in the Assay and the standard solution prepared here as directed under Liquid Chromatography <2.01> according to the following conditions, and determine each peak area by the automatic integration method: the area of the peaks other than cefalotin from the sample solution is not larger than the peak area of cefalotin from the standard solution, and the total area of the peaks other than cefalotin obtained from the sample solution is not larger than 3 times the peak area of cefalotin from the standard solution.

Operating conditions—

Detector, column, column temperature, mobile phase, and flow rate: Proceed as directed in the operating conditions in the Assay.

Time span of measurement: About 4 times as long as the retention time of cefalotin.

System suitability—

Test for required detectability: Measure exactly 1 mL of the standard solution, and add the mobile phase to make exactly 10 mL. Confirm that the peak area of cefalotin obtained with 10 μ L of this solution is equivalent to 7 to 13% of that with 10 μ L of the standard solution.

System performance: Heat the standard solution in a water bath of 90°C for 10 minutes, and cool. Measure exactly 2.5 mL of this solution, and add the mobile phase to make exactly 100 mL. When the procedure is run with 10 μ L of this solution under the above operating conditions, the resolution between the peak of cefalotin and the peak, having the relative retention time of about 0.5 to cefalotin, is not less than 9, and the symmetry factor of the peak of cefalotin is not more than 1.8.

System repeatability: When the test is repeated 3 times with 10 μ L of the standard solution under the above operating conditions, the relative standard deviation of the peak area of cefalotin is not more than 2.0%.

Water <2.48> Not more than 1.0% (0.5 g, volumetric titra-

tion, back titration).

Assay Weigh accurately an amount of Cefalotin Sodium and Cefalotin Sodium RS, equivalent to about 25 mg (potency), and dissolve each in the mobile phase to make exactly 25 mL, and use these solutions as the sample solution and standard solution. Perform the test with exactly 10 μ L each of the sample solution and standard solution as directed under Liquid Chromatography <2.01> according to the following conditions, and determine the peak areas, A_T and A_S , of cefalotin in each solution.

$$\text{Amount } [\mu\text{g (potency)}] \text{ of cefalotin (C}_{16}\text{H}_{16}\text{N}_2\text{O}_6\text{S}_2) \\ = M_S \times A_T / A_S \times 1000$$

M_S : Amount [mg (potency)] of Cefalotin Sodium RS taken

Operating conditions—

Detector: An ultraviolet absorption photometer (wavelength: 254 nm).

Column: A stainless steel column 4.6 mm in inside diameter and 25 cm in length, packed with octadecylsilylanized silica gel for liquid chromatography (5 μ m in particle diameter).

Column temperature: A constant temperature of about 40°C.

Mobile phase: Dissolve 17 g of sodium acetate trihydrate in 790 mL of water, and add 0.6 mL of acetic acid (100). If necessary adjust the pH to 5.9 ± 0.1 with diluted sodium hydroxide TS (1 in 10) or acetic acid (100). To this solution add 150 mL of acetonitrile and 70 mL of ethanol (95).

Flow rate: Adjust so that the retention time of cefalotin is about 12 minutes.

System suitability—

System performance: Heat the standard solution in a water bath of 90°C for 10 minutes, and cool. Measure exactly 2.5 mL of this solution, and add the mobile phase to make exactly 100 mL. When the procedure is run with 10 μ L of this solution under the above operating conditions, the resolution between the peak of cefalotin and the peak, having the relative retention time of about 0.5 to cefalotin is not less than 9, and the symmetry factor of the peak of cefalotin is not more than 1.8.

System repeatability: When the test is repeated 6 times with 10 μ L of the standard solution under the above operating conditions, the relative standard deviation of the peak area of cefalotin is not more than 1.0%.

Containers and storage Containers—Tight containers.

Cefalotin Sodium for Injection

注射用セファロチンナトリウム

Cefalotin Sodium for Injection is a preparation for injection, which is dissolved before use.

It contains not less than 90.0% and not more than 110.0% of the labeled potency of cefalotin (C₁₆H₁₆N₂O₆S₂: 396.44).

Method of preparation Prepare as directed under Injections, with Cefalotin Sodium.

Description Cefalotin Sodium for Injection occurs as white to light yellow-white, crystals or crystalline powder.

Identification Determine the infrared absorption spectrum of Cefalotin Sodium for Injection as directed in the potassium bromide disk method under Infrared Spectrophotome-

try <2.25>, and compare the spectrum with the Reference Spectrum of Cefalotin Sodium or the spectrum of Cefalotin Sodium RS: both spectra exhibit similar intensities of absorption at the same wave numbers.

pH <2.54> Dissolve an amount of Cefalotin Sodium for Injection, equivalent to 0.5 g (potency) of Cefalotin Sodium, in 5 mL of water: the pH of the solution is between 4.5 and 7.0.

Purity (1) Clarity and color of solution—Dissolve 1.0 g of Cefalotin Sodium for Injection in 10 mL of water: the solution is clear. Perform the test with this solution as directed under Ultraviolet-visible Spectrophotometry <2.24>: the absorbance at 450 nm is not more than 0.20.

(2) Related substances—Dissolve an amount of Cefalotin Sodium for Injection, equivalent to 25 mg (potency), in the mobile phase to make 25 mL, and use this solution as the sample solution. Pipet 1 mL of the sample solution, and add the mobile phase to make exactly 100 mL, and use this solution as the standard solution. Perform the test with exactly 10 μ L each of the sample solution and standard solution as directed under Liquid Chromatography <2.01> according to the following conditions, and determine each peak area by the automatic integration method: the area of the peak other than cefalotin obtained from the sample solution is not larger than the peak area of cefalotin from the standard solution, and the total area of the peaks other than cefalotin from the sample solution is not larger than 3 times the peak area of cefalotin from the standard solution.

Operating conditions—

Detector, column, column temperature, mobile phase and flow rate: Proceed as directed in the operating conditions in the Assay under Cefalotin Sodium.

Time span of measurement: About 4 times as long as the retention time of cefalotin.

System suitability—

Proceed as directed in the system suitability in the Purity (4) under Cefalotin Sodium.

Water <2.48> Not more than 1.0% (0.5 g, volumetric titration, back titration).

Bacterial endotoxins <4.01> Less than 0.2 EU/mg (potency).

Uniformity of dosage units <6.02> It meets the requirement of the Mass variation test.

Foreign insoluble matter <6.06> Perform the test according to Method 2: it meets the requirement.

Insoluble particulate matter <6.07> It meets the requirement.

Sterility <4.06> Perform the test according to the Membrane filtration method: it meets the requirement.

Assay Weigh accurately the mass of the contents of not less than 10 containers of Cefalotin Sodium for Injection. Weigh accurately an amount of the contents, equivalent to about 25 mg (potency) of Cefalotin Sodium, dissolve in the mobile phase to make exactly 25 mL, and use this solution as the sample solution. Separately, weigh accurately about 25 mg (potency) of Cefalotin Sodium RS, and dissolve in the mobile phase to make exactly 25 mL, and use this solution as the standard solution. Then, proceed as directed in the Assay under Cefalotin Sodium.

$$\begin{aligned} & \text{Amount } [\mu\text{g}(\text{potency})] \text{ of cefalotin } (\text{C}_{16}\text{H}_{16}\text{N}_2\text{O}_6\text{S}_2) \\ & = M_S \times A_T/A_S \times 1000 \end{aligned}$$

M_S : Amount [mg(potency)] of Cefalotin Sodium RS taken

Containers and storage Containers—Hermetic containers.

Cefatrizine Propylene Glycolate

セファトリジンプロピレングリコール

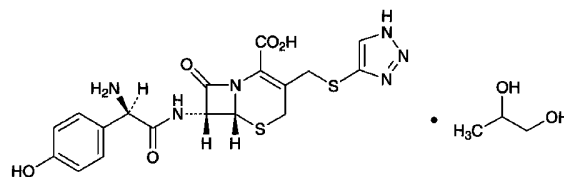

$\text{C}_{18}\text{H}_{18}\text{N}_6\text{O}_5\text{S}_2 \cdot \text{C}_3\text{H}_8\text{O}_2$: 538.60
(6*R*,7*R*)-7-[(2*R*)-2-Amino-2-(4-hydroxyphenyl)acetyl-amino]-8-oxo-3-[2-(1*H*-1,2,3-triazol-4-yl)sulfanylmethyl]-5-thia-1-azabicyclo[4.2.0]oct-2-ene-2-carboxylic acid monopropylene-1,2-diolate (1/1)
[51627-14-6, Cefatrizine]

Cefatrizine Propylene Glycolate contains not less than 816 μ g (potency) and not more than 876 μ g (potency) per mg, calculated on the anhydrous basis. The potency of Cefatrizine Propylene Glycolate is expressed as mass (potency) of cefatrizine ($\text{C}_{18}\text{H}_{18}\text{N}_6\text{O}_5\text{S}_2$: 462.50).

Description Cefatrizine Propylene Glycolate occurs as a white to yellowish white powder.

It is sparingly soluble in water, and practically insoluble in methanol and in ethanol (95).

Identification (1) Determine the absorption spectrum of a solution of Cefatrizine Propylene Glycolate (1 in 50,000) as directed under Ultraviolet-visible Spectrophotometry <2.24>, and compare the spectrum with the Reference Spectrum or the spectrum of a solution of Cefatrizine Propylene Glycolate RS prepared in the same manner as the sample solution: both spectra exhibit similar intensities of absorption at the same wavelengths.

(2) Determine the infrared absorption spectrum of Cefatrizine Propylene Glycolate as directed in the potassium bromide disk method under Infrared Spectrophotometry <2.25>, and compare the spectrum with the Reference Spectrum or the spectrum of Cefatrizine Propylene Glycolate RS: both spectra exhibit similar intensities of absorption at the same wave numbers.

(3) Determine the ^1H spectrum of a solution of Cefatrizine Propylene Glycolate in a mixture of heavy water for nuclear magnetic resonance spectroscopy and deuterated hydrochloric acid for nuclear magnetic resonance spectroscopy (3:1) (1 in 10), using sodium 3-(trimethylsilyl)propionate- d_4 for nuclear magnetic resonance spectroscopy as an internal reference compound, as directed under Nuclear Magnetic Resonance Spectroscopy <2.21>: it exhibits a doublet signal A at around δ 1.2 ppm, a doublet signal B at around δ 7.0 ppm, a doublet signal C at around δ 7.5 ppm and a singlet signal D at around δ 8.3 ppm. The ratio of integrated intensity of these signals, A:B:C:D, is about 3:2:2:1.

Optical rotation <2.49> $[\alpha]_D^{20}$: +52 – +58° (2.5 g calculated on the anhydrous bases, 1 mol/L hydrochloric acid TS, 50 mL, 100 mm).

Purity (1) Heavy metals <1.07>—Proceed with 1.0 g of Cefatrizine Propylene Glycolate according to Method 2, and

perform the test. Prepare the control solution with 2.0 mL of Standard Lead Solution (not more than 20 ppm).

(2) Arsenic <1.11>—Prepare the test solution with 1.0 g of Cefatrizine Propylene Glycolate according to Method 3, and perform the test (not more than 2 ppm). Use a solution of magnesium nitrate hexahydrate in ethanol (1 in 25).

(3) Related substances—Dissolve 25 mg of Cefatrizine Propylene Glycolate in 5 mL of water, and use this solution as the sample solution. Pipet 1 mL of the sample solution, add water to make exactly 20 mL, and use this solution as the standard solution. Perform the test with these solutions as directed under Thin-layer Chromatography <2.03>. Spot 5 μ L each of the sample solution and standard solution on a plate of silica gel for thin-layer chromatography. Develop with a mixture of 1-butanol, water and acetic acid (100) (3:1:1) to a distance of about 12 cm, and air-dry the plate. Spray evenly ninhydrin-citric acid-acetic acid TS on the plate, and heat the plate at 100°C for 10 minutes: the spots other than the principal spot obtained from the sample solution are not more intense than the spot from the standard solution.

Water <2.48> Not more than 2.0% (0.5 g, volumetric titration, direct titration).

Assay Weigh accurately an amount of Cefatrizine Propylene Glycolate and Cefatrizine Propylene Glycolate RS, equivalent to about 0.1 g (potency), dissolve each in water to make exactly 500 mL, and use these solutions as the sample solution and the standard solution, respectively. Perform the test with exactly 10 μ L each of the sample solution and standard solution as directed under Liquid Chromatography <2.01> according to the following conditions, and determine the peak areas, A_T and A_S , of cefatrizine in each solution.

$$\text{Amount } [\mu\text{g (potency)}] \text{ of cefatrizine (C}_{18}\text{H}_{18}\text{N}_6\text{O}_5\text{S}_2) \\ = M_S \times A_T / A_S \times 1000$$

M_S : Amount [mg (potency)] of Cefatrizine Propylene Glycolate RS taken

Operating conditions—

Detector: An ultraviolet absorption photometer (wavelength: 270 nm).

Column: A stainless steel column 4.6 mm in inside diameter and 25 cm in length, packed with octadecylsilanized silica gel for liquid chromatography (5 μ m in particle diameter).

Column temperature: A constant temperature of about 40°C.

Mobile phase: A mixture of a solution of potassium dihydrogenphosphate (17 in 12,500) and methanol (17:3).

Flow rate: Adjust so that the retention time of cefatrizine is about 11 minutes.

System suitability—

System performance: Dissolve about 10 mg (potency) of Cefatrizine Propylene Glycolate and about 5 mg (potency) of Cefadroxil in 50 mL of water. When the procedure is run with 10 μ L of this solution under the above operating conditions, cefadroxil and cefatrizine are eluted in this order with the resolution between these peaks being not less than 4.

System repeatability: When the test is repeated 6 times with 10 μ L of the standard solution under the above operating conditions, the relative standard deviation of peak areas of cefatrizine is not more than 1.0%.

Containers and storage Containers—Tight containers.

Cefatrizine Propylene Glycolate for Syrup

シロップ用セファトリジンプロピレングリコール

Cefatrizine Propylene Glycolate for Syrup is a preparation for syrup, which is dissolved before use.

It contains not less than 90.0% and not more than 105.0% of the labeled potency of Cefatrizine (C₁₈H₁₈N₆O₅S₂: 462.50).

Method of preparation Prepare as directed under Preparations for Syrup, with Cefatrizine Propylene Glycolate.

Identification Powder Cefatrizine Propylene Glycolate for Syrup, weigh a portion of the powder, equivalent to 10 mg (potency) of Cefatrizine Propylene Glycolate, and dissolve in 10 mL of water. To 2 mL of this solution add water to make 100 mL. Determine the absorption spectrum of this solution as directed under Ultraviolet-visible Spectrophotometry <2.24>: it exhibits maxima between 225 nm and 229 nm, and between 266 nm and 271 nm.

pH <2.54> Take an amount of Cefatrizine Propylene Glycolate for Syrup, equivalent to 0.4 g (potency) of Cefatrizine Propylene Glycolate, and suspend in 10 mL of water: the pH of this suspension is between 4.0 and 6.0.

Purity Related substances—Use the sample solution obtained in the Assay as the sample solution. Pipet 1 mL of the sample solution, add water to make exactly 100 mL, and use this solution as the standard solution. Perform the test with exactly 10 μ L each of the sample solution and standard solution as directed under Liquid Chromatography <2.01> according to the following conditions. Determine each peak area in each solution by the automatic integration method: the area of each peak other than cefatrizine obtained from the sample solution is not larger than the peak area of cefatrizine from the standard solution, and the total area of the peaks other than cefatrizine from the sample solution is not larger than 2 times the peak area of cefatrizine from the standard solution.

Operating conditions—

Detector, column, column temperature, mobile phase and flow rate: Proceed as directed in the operating conditions in the Assay under Cefatrizine Propylene Glycolate.

Time span of measurement: About 2.5 times as long as the retention time of cefatrizine, beginning after the solvent peak.

System suitability—

System performance: Proceed as directed in the system suitability in the Assay under Cefatrizine Propylene Glycolate.

Test for required detectability: Pipet 2 mL of the standard solution, and add water to make exactly 10 mL. Confirm that the peak area of cefatrizine obtained with 10 μ L of this solution is equivalent to 15 to 25% of that with 10 μ L of the standard solution.

System repeatability: When the test is repeated 6 times with 10 μ L of the standard solution under the above operating conditions, the relative standard deviation of the peak area of cefatrizine is not more than 2.0%.

Uniformity of dosage units <6.02> Cefatrizine Propylene Glycolate for Syrup in single-dose packages meets the requirement of the Mass variation test.

Assay Powder Cefatrizine Propylene Glycolate for Syrup,

weigh accurately a portion of the powder, equivalent to about 0.1 g (potency) of Cefatrizine Propylene Glycolate, dissolve in water to make exactly 500 mL, and use this solution as the sample solution. Separately, weigh accurately an amount of Cefatrizine Propylene Glycolate RS, equivalent to about 20 mg (potency), dissolve in water to make exactly 100 mL, and use this solution as the standard solution. Then, proceed as directed in the Assay under Cefatrizine Propylene Glycolate.

$$\begin{aligned} &\text{Amount [mg (potency)] of cefatrizine (C}_{18}\text{H}_{18}\text{N}_6\text{O}_5\text{S}_2) \\ &= M_S \times A_T/A_S \times 5 \end{aligned}$$

M_S : Amount [mg (potency)] of Cefatrizine Propylene Glycolate RS taken

Containers and storage Containers—Tight containers.

Cefazolin Sodium

セファゾリンナトリウム

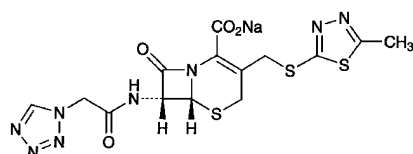

$\text{C}_{14}\text{H}_{13}\text{N}_8\text{NaO}_4\text{S}_3$: 476.49

Monosodium (6*R*,7*R*)-3-(5-methyl-1,3,4-thiadiazol-2-ylsulfanylmethyl)-8-oxo-7-[2-(1*H*-tetrazol-1-yl)acetyl]amino]-5-thia-1-azabicyclo[4.2.0]oct-2-ene-2-carboxylate
[27164-46-1]

Cefazolin Sodium contains not less than 900 μg (potency) and not more than 975 μg (potency) per mg, calculated on the anhydrous basis. The potency of Cefazolin Sodium is expressed as mass (potency) of cefazolin ($\text{C}_{14}\text{H}_{14}\text{N}_8\text{O}_4\text{S}_3$: 454.51).

Description Cefazolin Sodium occurs as a white to light yellow-white, crystals or crystalline powder.

It is freely soluble in water and in formamide, slightly soluble in methanol, and practically insoluble in ethanol (95).

Identification (1) Determine the absorption spectrum of a solution of Cefazolin Sodium (1 in 50,000) as directed under Ultraviolet-visible Spectrophotometry <2.24>, and compare the spectrum with the Reference Spectrum: both spectra exhibit similar intensities of absorption at the same wavelengths.

(2) Determine the infrared absorption spectrum of Cefazolin Sodium as directed in the potassium bromide disk method under Infrared Spectrophotometry <2.25>, and compare the spectrum with the Reference Spectrum: both spectra exhibit similar intensities of absorption at the same wave numbers.

(3) Determine the ^1H spectrum of a solution of Cefazolin Sodium in heavy water for nuclear magnetic resonance spectroscopy (1 in 10), using sodium 3-trimethylsilylpropionate- d_4 for nuclear magnetic resonance spectroscopy as an internal reference compound, as directed under Nuclear Magnetic Resonance Spectroscopy <2.21>: it exhibits singlet signals, A and B, at around δ 2.7 ppm and at around δ 9.3 ppm, respectively. The ratio of integrated intensity of these signals, A:B, is about 3:1.

(4) Cefazolin Sodium responds to Qualitative Tests <1.09> (1) for sodium salt.

Optical rotation <2.49> $[\alpha]_D^{20}$: $-19 - -23^\circ$ (2.5 g calculated as the anhydrous basis, water, 25 mL, 100 mm).

pH <2.54> Dissolve 1.0 g of Cefazolin Sodium in 10 mL of water: pH of the solution is between 4.8 and 6.3.

Purity (1) Clarity and color of solution—Dissolve 1.0 g of Cefazolin Sodium in 10 mL of water: the solution is clear and colorless to pale yellow, and its absorbance at 400 nm determined as directed under Ultraviolet-visible Spectrophotometry <2.24> is not more than 0.35. The test should be performed within 10 minutes after preparing of the solution.

(2) Heavy metals <1.07>—Proceed with 2.0 g of Cefazolin Sodium according to Method 2, and perform the test. Prepare the control solution with 2.0 mL of Standard Lead Solution (not more than 10 ppm).

(3) Arsenic <1.11>—Prepare the test solution with 2.0 g of Cefazolin Sodium according to Method 3, and perform the test. When prepare the test solution, add 1.5 mL of hydrogen peroxide (30) after addition of 10 mL of a solution of magnesium nitrate hexahydrate in ethanol (95) (1 in 50), and then ignite (not more than 1 ppm).

(4) Related substances—Dissolve 0.10 g of Cefazolin Sodium in 20 mL of 0.1 mol/L phosphate buffer solution (pH 7.0) and use this solution as the sample solution. Prepare the sample solution before use. Perform the test with 5 μL of the sample solution as directed under Liquid Chromatography <2.01> according to the following conditions. Determine each peak area by the automatic integration method, and calculate the amount of the peaks by the area percentage method: the amount of the peak, having the relative retention time of about 0.2 to cefazolin and the amount of the peak other than cefazolin and the peak mentioned above are not more than 1.5%, respectively. The total amount of the peaks other than cefazolin is not more than 2.5%. For the area of the peak, having the relative retention time of about 0.2 to the cefazolin, multiply the correction factor, 1.43.

Operating conditions—

Detector, column, column temperature, mobile phase, and flow rate: Proceed as directed in the operating conditions in the Assay.

Time span of measurement: About 3 times as long as the retention time of cefazolin, beginning after the solvent peak.

System suitability—

System performance: Proceed as directed in the system suitability in the Assay.

Test for required detectability: Dissolve about 80 mg of Cefazolin RS in 0.1 mol/L phosphate buffer solution (pH 7.0) to make 100 mL, and use this solution as the solution for system suitability test. Pipet 1 mL of the solution for system suitability test, and add 0.1 mol/L phosphate buffer solution (pH 7.0) to make exactly 20 mL. Confirm that the peak area of cefazolin obtained with 5 μL of this solution is equivalent to 3 to 7% of that with 5 μL of the solution for system suitability test.

System repeatability: When the test is repeated 6 times with 5 μL of the solution for system suitability test under the above operating conditions, the relative standard deviation of the peak areas of cefazolin is not more than 1.0%.

Water <2.48> Not more than 2.5% (1.0 g, volumetric titration, direct titration. Use a mixture of formamide for water determination and methanol for water determination (2:1) instead of methanol for water determination).

Assay Weigh accurately an amount of Cefazolin Sodium

and Cefazolin RS, equivalent to about 20 mg (potency), dissolve each in the internal standard solution to make exactly 20 mL, and use these solutions as the sample solution and the standard solution, respectively. Perform the test with 5 μ L each of the sample solution and standard solution as directed under Liquid Chromatography <2.01> according to the following conditions, and calculate the ratios, Q_T and Q_S , of the peak area of cefazolin to that of the internal standard.

$$\begin{aligned} & \text{Amount } [\mu\text{g (potency)}] \text{ of cefazolin } (\text{C}_{14}\text{H}_{14}\text{N}_8\text{O}_4\text{S}_3) \\ & = M_S \times Q_T / Q_S \times 1000 \end{aligned}$$

M_S : Amount [mg (potency)] of Cefazolin RS taken

Internal standard solution—A solution of *p*-acetanisidide in 0.1 mol/L phosphate buffer solution (pH 7.0) (11 in 20,000).

Operating conditions—

Detector: An ultraviolet absorption photometer (wavelength: 254 nm).

Column: A stainless steel column 4 mm in inside diameter and 15 cm in length, packed with octadecylsilylanized silica gel for liquid chromatography (10 μ m in particle diameter).

Column temperature: A constant temperature of about 25°C.

Mobile phase: Dissolve 2.27 g of disodium hydrogen phosphate dodecahydrate and 0.47 g of citric acid monohydrate in water to make 935 mL, and add 65 mL of acetonitrile.

Flow rate: Adjust so that the retention time of cefazolin is about 8 minutes.

System suitability—

System performance: When the procedure is run with 5 μ L of the standard solution under the above operating conditions, cefazolin and the internal standard are eluted in this order with the resolution between these peaks being not less than 4.

System repeatability: When the test is repeated 6 times with 5 μ L of the standard solution under the above operating conditions, the relative standard deviation of the ratios of the peak area of cefazolin to that of the internal standard is not more than 1.0%.

Containers and storage Containers—Tight containers.

Cefazolin Sodium for Injection

注射用セファゾリンナトリウム

Cefazolin Sodium for Injection is a preparation for injection which is dissolved before use.

It contains not less than 90.0% and not more than 110.0% of the labeled potency of cefazolin ($\text{C}_{14}\text{H}_{14}\text{N}_8\text{O}_4\text{S}_3$; 454.51).

Method of preparation Prepare as directed under Injections, with Cefazolin Sodium.

Description Cefazolin Sodium for Injection occurs as white to light yellow-white, crystals or crystalline powder or masses.

Identification (1) Determine the absorption spectrum of a solution of Cefazolin Sodium for Injection (1 in 50,000) as directed under Ultraviolet-visible Spectrophotometry <2.24>: it exhibits a maximum between 270 nm and 274 nm.

(2) Cefazolin Sodium for Injection responds to Qualitative Tests <1.09> (1) for chloride.

Osmotic pressure ratio Being specified separately when the

drug is granted approval based on the Law.

pH <2.54> The pH of a solution prepared by dissolving an amount of Cefazolin Sodium for Injection, equivalent to 1.0 g (potency) of Cefazolin Sodium, in 10 mL of water is 4.5 to 6.5.

Purity (1) Clarity and color of solution—Conduct this procedure within 10 minutes after the preparation of the solutions. A solution prepared by dissolving an amount of Cefazolin Sodium for Injection, equivalent to 1.0 g (potency) of Cefazolin Sodium, in 10 mL of water is clear, and the absorbance of this solution at 400 nm, determined as directed under Ultraviolet-visible Spectrophotometry <2.24>, is not more than 0.35.

(2) Related substances—Dissolve an amount of Cefazolin Sodium for Injection, equivalent to 0.10 g (potency) of Cefazolin Sodium, in 20 mL of 0.1 mol/L phosphate buffer solution (pH 7.0) and use this solution as the sample solution. Prepare the sample solution before use. Perform the test with 5 μ L of the sample solution as directed under Liquid Chromatography <2.01> according to the following conditions, and determine each peak area by the automatic integration method. Calculate the amount of each peak by the area percentage method: the amount of the peaks other than cefazolin is not more than 1.5%. Furthermore the total amount of the peaks other than cefazolin is not more than 2.5%. For the area of the peak, having the relative retention time of about 0.2 to cefazolin, multiply the correction factor, 1.43.

Operating conditions—

Detector, column, column temperature, mobile phase, and flow rate: Proceed as directed in the operating conditions in the Assay under Cefazolin Sodium.

Time span of measurement: About 3 times as long as the retention time of cefazolin, beginning after the solvent peak.

System suitability—

System performance: Proceed as directed in the system suitability in the Assay under Cefazolin Sodium.

Test for required detectability: To 8 mL of the sample solution, add 0.1 mol/L phosphate buffer solution (pH 7.0) to make 50 mL, and use this solution as the solution for system suitability test. Pipet 1 mL of the solution for system suitability test, add 0.1 mol/L phosphate buffer solution (pH 7.0) to make exactly 20 mL. Confirm that the peak area of cefazolin obtained with 5 μ L of this solution is equivalent to 3 to 7% of that with 5 μ L of the solution for system suitability test.

System repeatability: When the test is repeated 6 times with 5 μ L of the solution for system suitability test under the above operating conditions, the relative standard deviation of the peak area of cefazolin is not more than 1.0%.

Water <2.48> Not more than 3.0% (0.5 g, volumetric titration, direct titration). Use a mixture of formamide for water determination and methanol for water determination (2:1) instead of methanol for water determination.

Bacterial endotoxins <4.01> Less than 0.05 EU/mg (potency).

Uniformity of dosage units <6.02> It meets the requirement of the Mass variation test.

Foreign insoluble matter <6.06> Perform the test according to Method 2: it meets the requirement.

Insoluble particulate matter <6.07> It meets the requirement.

Sterility <4.06> Perform the test according to the Mem-

brane filtration method: it meets the requirement.

Assay Weigh accurately the mass of the contents of not less than 10 containers of Cefazolin Sodium for Injection. Weigh accurately an amount of the contents, equivalent to about 50 mg (potency) of Cefazolin Sodium, dissolve in the internal standard solution to make exactly 50 mL, and use this solution as the sample solution. Separately, weigh accurately an amount of Cefazolin RS, equivalent to about 50 mg (potency), dissolve in the internal standard solution to make exactly 50 mL, and use this solution as the standard solution. Then, proceed as directed in the Assay under Cefazolin Sodium.

$$\text{Amount [mg (potency)] of cefazolin (C}_{14}\text{H}_{14}\text{N}_8\text{O}_4\text{S}_3) \\ = M_S \times Q_T/Q_S$$

M_S : Amount [mg (potency)] of Cefazolin RS taken

Internal standard solution—A solution of *p*-acetanisidide in 0.1 mol/L phosphate buffer solution (pH 7.0) (11 in 20,000).

Containers and storage Containers—Hermetic containers. Plastic containers for aqueous injections may be used.

Cefazolin Sodium Hydrate

セファゾリンナトリウム水和物

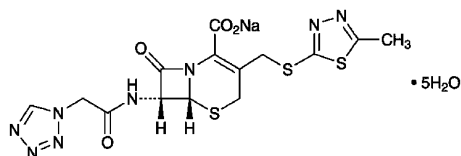

$\text{C}_{14}\text{H}_{13}\text{N}_8\text{NaO}_4\text{S}_3 \cdot 5\text{H}_2\text{O}$: 566.57

Monosodium (6*R*,7*R*)-3-(5-methyl-1,3,4-thiadiazol-2-ylsulfanylmethyl)-8-oxo-7-[2-(1*H*-tetrazol-1-yl)acetylamino]-5-thia-1-azabicyclo[4.2.0]oct-2-ene-2-carboxylate pentahydrate
[115850-11-8]

Cefazolin Sodium Hydrate contains not less than 920 μg (potency) and not more than 975 μg (potency) per mg, calculated on the anhydrous basis. The potency of Cefazolin Sodium Hydrate is expressed as mass (potency) of cefazolin ($\text{C}_{14}\text{H}_{14}\text{N}_8\text{O}_4\text{S}_3$: 454.51).

Description Cefazolin Sodium Hydrate occurs as white to pale yellowish white crystals.

It is freely soluble in water, sparingly soluble in methanol, slightly soluble in ethanol (95), and practically insoluble in diethyl ether.

Identification (1) Determine the absorption spectrum of a solution of Cefazolin Sodium Hydrate (1 in 50,000) as directed under Ultraviolet-visible Spectrophotometry <2.24>, and compare the spectrum with the Reference Spectrum: both spectra exhibit similar intensities of absorption at the same wavelengths.

(2) Determine the infrared absorption spectrum of Cefazolin Sodium Hydrate as directed in the potassium bromide disk method under Infrared Spectrophotometry <2.25>, and compare the spectrum with the Reference Spectrum: both spectra exhibit similar intensities of absorption at the same wave numbers.

(3) Determine the ^1H spectrum of a solution of Cefazolin Sodium Hydrate in heavy water for nuclear magnetic resonance spectroscopy (1 in 10), using sodium 3-trimethylsilyl-

propionate- d_4 for nuclear magnetic resonance spectroscopy as an internal reference compound, as directed under Nuclear Magnetic Resonance Spectroscopy <2.21>: it exhibits singlet signals, A and B, at around δ 2.7 ppm and at around δ 9.3 ppm. The ratio of integrated intensity of each signal, A:B, is about 3:1.

(4) Cefazolin Sodium Hydrate responds to Qualitative Tests <1.09> (1) for sodium salt.

Absorbance <2.24> $E_{1\text{cm}}^{1\%}$ (272 nm): 272 – 292 (80 mg calculated on the anhydrous basis, water, 5000 mL).

Optical rotation <2.49> $[\alpha]_D^{20}$: -20 – -25° (2.5 g calculated on the anhydrous basis, water, 25 mL, 100 mm).

pH <2.54> Dissolve 1.0 g of Cefazolin Sodium Hydrate in 10 mL of water: the pH of the solution is between 4.8 and 6.3.

Purity (1) Clarity and color of solution—Dissolve 1.0 g of Cefazolin Sodium Hydrate in 10 mL of water: the solution is clear, and when determine the absorbance at 400 nm of this solution as directed under Ultraviolet-visible Spectrophotometry <2.24>, it is not more than 0.15.

(2) Heavy metals <1.07>—Proceed with 2.0 g of Cefazolin Sodium Hydrate according to Method 2, and perform the test. Prepare the control solution with 2.0 mL of Standard Lead Solution (not more than 10 ppm).

(3) Related substances—Dissolve 0.10 of Cefazolin Sodium Hydrate in 20 mL of 0.1 mol/L phosphate buffer solution (pH 7.0) and use this solution as the sample solution. Perform the test with 5 μL of the sample solution as directed under Liquid Chromatography <2.01> according to the following conditions. Determine each peak area by the automatic integration method, and calculate the amount of them by the area percentage method: the amount of the peak having the relative retention time of about 0.2 to cefazolin is not more than 1.0%, the amount of the peak other than cefazolin and the peak mentioned above is not more than 0.5%, and the total amount of the peaks other than cefazolin is not more than 2.0%. For the area of the peak, having the relative retention time of about 0.2 to cefazolin, multiply the correction factor 1.43.

Operating conditions—

Detector, column, column temperature, mobile phase, and flow rate: Proceed as directed in the operating conditions in the Assay.

Time span of measurement: About 3 times as long as the retention time of cefazolin, beginning after the solvent peak.

System suitability—

Test for required detectability: To 1 mL of the sample solution add 0.1 mol/L phosphate buffer solution (pH 7.0) to make 100 mL, and use this solution as the solution for system suitability test. Pipet 1 mL of the solution for system suitability test, add 0.1 mol/L phosphate buffer solution (pH 7.0) to make exactly 10 mL. Confirm that the peak area of cefazolin obtained with 5 μL of this solution is equivalent to 7 to 13% of that with 5 μL of the solution for system suitability test.

System performance: Dissolve 20 mg of Cefazolin Sodium Hydrate in 20 mL of a solution of *p*-acetanisidide in 0.1 mol/L phosphate buffer solution (pH 7.0) (11 in 20,000). When the procedure is run with 5 μL of this solution under the above operating conditions, cefazolin and *p*-acetanisidide are eluted in this order with the resolution between these peaks being not less than 4.

System repeatability: When the test is repeated 6 times with 5 μL of the solution for system suitability test under the above operating conditions, the relative standard deviation

of the peak area of cefazolin is not more than 2.0%.

Water <2.48> Not less than 13.7% and not more than 16.0% (0.1 g, volumetric titration, direct titration. Use a mixture of formamide for water determination and methanol for water determination (2:1) instead of methanol for water determination).

Bacterial endotoxins <4.01> Less than 0.10 EU/mg (potency).

Assay Weigh accurately an amount of Cefazolin Sodium Hydrate and Cefazolin RS, equivalent to about 20 mg (potency), dissolve in exactly 20 mL of the internal standard solution, and use these solutions as the sample solution and standard solution. Perform the test with 5 μ L each of the sample solution and standard solution as directed under Liquid Chromatography <2.01> according to the following conditions, and calculate the ratios, Q_T and Q_S , of the peak area of cefazolin to that of the internal standard.

$$\begin{aligned} \text{Amount } [\mu\text{g (potency)}] \text{ of cefazolin (C}_{14}\text{H}_{14}\text{N}_8\text{O}_4\text{S}_3) \\ = M_S \times Q_T / Q_S \times 1000 \end{aligned}$$

M_S : Amount [mg (potency)] of Cefazolin RS taken

Internal standard solution—A solution of *p*-acetanisidide in 0.1 mol/L phosphate buffer solution (pH 7.0) (11 in 20,000).

Operating conditions—

Detector: An ultraviolet absorption photometer (wavelength: 254 nm).

Column: A stainless steel column 4 mm in inside diameter and 15 cm in length, packed with octadecylsilanized silica gel for liquid chromatography (10 μ m in particle diameter).

Column temperature: A constant temperature of about 25°C.

Mobile phase: Dissolve 2.27 g of disodium hydrogen phosphate dodecahydrate and 0.47 g of citric acid monohydrate in water to make 935 mL. To this solution, add 65 mL of acetonitrile.

Flow rate: Adjust so that the retention time of cefazolin is about 8 minutes.

System suitability—

System performance: When the procedure is run with 5 μ L of the standard solution under the above operating conditions, cefazolin and the internal standard are eluted in this order with the resolution between these peaks being not less than 4.

System repeatability: When the test is repeated 6 times with 5 μ L of the standard solution under the above operating conditions, the relative standard deviation of the peak area of cefazolin is not more than 1.0%.

Containers and storage Containers—Hermetic containers.

Storage—Light-resistant.

Cefbuperazone Sodium

セフブペラゾンナトリウム

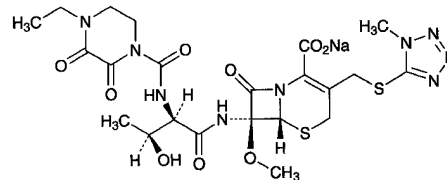

$\text{C}_{22}\text{H}_{28}\text{N}_9\text{NaO}_9\text{S}_2$; 649.63

Monosodium (6*R*,7*S*)-7-[(2*R*,3*S*)-2-[(4-ethyl-2,3-dioxopiperazine-1-carbonyl)amino]-3-hydroxybutanoylamino]-7-methoxy-3-(1-methyl-1*H*-tetrazol-5-ylsulfanyl)methyl)-8-oxo-5-thia-1-azabicyclo[4.2.0]oct-2-ene-2-carboxylate [76648-01-6]

Cefbuperazone Sodium contains not less than 870 μ g (potency) per mg, calculated on the anhydrous basis. The potency of Cefbuperazone Sodium is expressed as mass (potency) of cefbuperazone ($\text{C}_{22}\text{H}_{29}\text{N}_9\text{O}_9\text{S}_2$; 627.65).

Description Cefbuperazone Sodium occurs as white to light yellow-white, powder or masses.

It is very soluble in water, freely soluble in methanol and in pyridine, sparingly soluble in ethanol (95), and very slightly soluble in acetonitrile.

Identification (1) Determine the absorption spectrum of a solution of Cefbuperazone Sodium (1 in 50,000) as directed under Ultraviolet-visible Spectrophotometry <2.24>, and compare the spectrum with the Reference Spectrum: both spectra exhibit similar intensities of absorption at the same wavelengths.

(2) Dissolve 0.1 g of Cefbuperazone Sodium in 0.5 mL of deuterated pyridine for nuclear magnetic resonance spectroscopy and 1 drop of heavy water for nuclear magnetic resonance spectroscopy, and determine the ^1H spectrum of this solution as directed under Nuclear Magnetic Resonance Spectroscopy <2.21>, using tetramethylsilane for nuclear magnetic resonance spectroscopy as an internal reference compound: it exhibits a triplet signal A at around δ 1.1 ppm, and two doublet signals, B and C, at around δ 1.6 ppm and at around δ 5.1 ppm, respectively. The ratio of the integrated intensity of each signal, A:B:C, is about 3:3:1.

(3) Cefbuperazone Sodium responds to Qualitative Tests <1.09> (1) for sodium salt.

Optical rotation <2.49> $[\alpha]_D^{20}$: +48 – +56° (0.4 g calculated on the anhydrous basis, water, 20 mL, 100 mm).

pH <2.54> Dissolve 1.0 g of Cefbuperazone Sodium in 4 mL of water: the pH of the solution is between 4.0 and 6.0.

Purity (1) Clarity and color of solution—Dissolve 1.0 g of Cefbuperazone Sodium in 4 mL of water: the solution is clear and light yellow.

(2) Heavy metals <1.07>—Proceed with 2.0 g of Cefbuperazone Sodium according to Method 4, and perform the test. Prepare the control solution with 2.0 mL of Standard Lead Solution (not more than 10 ppm).

(3) Arsenic <1.11>—Prepare the test solution with 1.0 g of Cefbuperazone Sodium according to Method 4, and perform the test (not more than 2 ppm).

(4) Related substances—Dissolve 0.10 g of Cefbupera-

zone Sodium in 100 mL of the mobile phase, and use this solution as the sample solution. Pipet 1 mL of the sample solution, add the mobile phase to make exactly 50 mL, and use this solution as the standard solution. Perform the test with exactly 25 μ L each of the sample solution and standard solution as directed under Liquid Chromatography <2.01> according to the following conditions, and determine each peak area by the automatic integration method. Calculate the percentages of each peak area of related substances obtained from the sample solution against 50 times of the peak area of cefbuperazone from the standard solution; the amount of related substance I having the relative retention time of about 0.2 to cefbuperazone is not more than 2.0%, the amount of related substance II having the relative retention time of about 0.6 is not more than 4.5% and the amount of related substance III having the relative retention time of about 1.6 is not more than 1.0%, and the total amount of these related substances is not more than 6.0%. For the peak areas of the related substances I and III, multiply their correction factors, 0.72 and 0.69, respectively.

Operating conditions—

Detector, column, column temperature, mobile phase, and flow rate: Proceed as directed in the operating conditions in the Assay.

Time span of measurement: About 2 times as long as the retention time of cefbuperazone.

System suitability—

Test for required detectability: Measure exactly 1 mL of the standard solution, and add the mobile phase to make exactly 10 mL. Confirm that the peak area of cefbuperazone obtained with 25 μ L of this solution is equivalent to 7 to 13% of that with 25 μ L of the standard solution.

System performance: When the procedure is run with 25 μ L of the standard solution under the above operating conditions, the number of theoretical plates and the symmetry factor of the peak of cefbuperazone are not less than 5000 and not more than 1.5, respectively.

System repeatability: When the test is repeated 6 times with 25 μ L of the standard solution under the above operating conditions, the relative standard deviation of the peak area of cefbuperazone is not more than 2.0%.

Water <2.48> Not more than 1.0% (3 g, volumetric titration, direct titration).

Assay Weigh accurately an amount of Cefbuperazone Sodium and Cefbuperazone RS, equivalent to about 0.1 g (potency), and dissolve each in the mobile phase to make exactly 100 mL. Measure exactly 10 mL each of these solutions, add exactly 10 mL of the internal standard solution and the mobile phase to make 50 mL, and use these solutions as the sample solution and standard solution. Perform the test with 10 μ L each of the sample solution and standard solution as directed under Liquid Chromatography <2.01> according to the following conditions, and calculate the ratios, Q_T and Q_S , of the peak area of cefbuperazone to that of the internal standard.

$$\text{Amount } [\mu\text{g (potency)}] \text{ of cefbuperazone (C}_{22}\text{H}_{29}\text{N}_9\text{O}_9\text{S}_2) \\ = M_S \times Q_T / Q_S \times 1000$$

M_S : Amount [mg (potency)] of Cefbuperazone RS taken

Internal standard solution—A solution of acetanilide in the mobile phase (1 in 4000).

Operating conditions—

Detector: An ultraviolet absorption photometer (wavelength: 254 nm).

Column: A stainless steel column 4.6 mm in inside diame-

ter and 15 cm in length, packed with octadecylsilanized silica gel for liquid chromatography (5 μ m in particle diameter).

Column temperature: A constant temperature of about 25°C.

Mobile phase: Dissolve 2.0 g of tetra-*n*-propylammonium bromide in 1000 mL of a mixture of water, acetonitrile and acetic acid-sodium acetate buffer solution (pH 5.0) (83:13:4).

Flow rate: Adjust so that the retention time of cefbuperazone is about 16 minutes.

System suitability—

System performance: When the procedure is run with 10 μ L of the standard solution under the above operating conditions, the internal standard and cefbuperazone are eluted in this order with the resolution between these peaks being not less than 3.

System repeatability: When the test is repeated 6 times with 10 μ L of the standard solution under the above operating conditions, the relative standard deviation of the ratios of the peak area of cefbuperazone to that of the internal standard is not more than 1.0%.

Containers and storage Containers—Hermetic containers.

Storage—In a cold place.

Cefcapene Pivoxil Hydrochloride Hydrate

セフカペン ピボキシル塩酸塩水和物

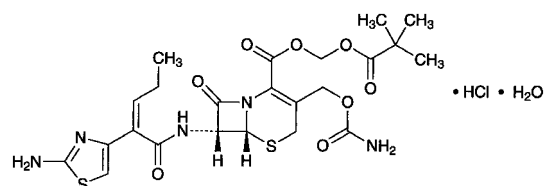

$\text{C}_{23}\text{H}_{29}\text{N}_5\text{O}_8\text{S}_2 \cdot \text{HCl} \cdot \text{H}_2\text{O}$: 622.11

2,2-Dimethylpropanoyloxymethyl (6*R*,7*R*)-7-[(2*Z*)-2-(2-aminothiazol-4-yl)pent-2-enoylamino]-3-carbamoyloxymethyl-8-oxo-5-thia-1-azabicyclo[4.2.0]oct-2-ene-2-carboxylate monohydrochloride monohydrate [147816-24-8]

Cefcapene Pivoxil Hydrochloride Hydrate contains not less than 722 μ g (potency) and not more than 764 μ g (potency) per mg, calculated on the anhydrous basis. The potency of Cefcapene Pivoxil Hydrochloride Hydrate is expressed as mass (potency) of cefcapene ($\text{C}_{17}\text{H}_{19}\text{N}_5\text{O}_6\text{S}_2$: 453.49).

Description Cefcapene Pivoxil Hydrochloride Hydrate occurs as a white to pale yellow-white, crystalline powder or mass. It has slightly a characteristic odor.

It is freely soluble in *N,N*-dimethylformamide and in methanol, soluble in ethanol (99.5), slightly soluble in water, and practically insoluble in diethyl ether.

Identification (1) Determine the absorption spectrum of a solution of Cefcapene Pivoxil Hydrochloride Hydrate in methanol (1 in 50,000) as directed under Ultraviolet-visible Spectrophotometry <2.24>, and compare the spectrum with the Reference Spectrum or the spectrum of a solution of Cefcapene Pivoxil Hydrochloride RS prepared in the same manner as the sample solution: both spectra exhibit similar intensities of absorption at the same wavelengths.

(2) Determine the infrared absorption spectra of Cefca-

pene Pivoxil Hydrochloride Hydrate and Cefcapene Pivoxil Hydrochloride RS as directed in the paste method under Infrared Spectrophotometry <2.25>, and compare these spectra: both spectra exhibit similar intensities of absorption at the same wave numbers.

(3) Determine the ^1H spectrum of a solution of Cefcapene Pivoxil Hydrochloride Hydrate in deuterated methanol for nuclear magnetic resonance spectroscopy (1 in 50) as directed under Nuclear Magnetic Resonance Spectroscopy <2.21>, using tetramethylsilane for nuclear magnetic resonance spectroscopy as an internal reference compound: it exhibits a triplet signal A at around δ 6.3 ppm, and a single signal B at around δ 6.7 ppm, and the ratio of integrated intensity of each signal, A:B, is about 1:1.

(4) Dissolve 10 mg of Cefcapene Pivoxil Hydrochloride Hydrate in 2 mL of a mixture of water and methanol (1:1), and add 1 drop of silver nitrate TS: a white precipitate is formed.

Optical rotation <2.49> $[\alpha]_{\text{D}}^{20}$: +51 – +54° (0.1 g calculated on the anhydrous basis, methanol, 10 mL, 100 mm).

Purity (1) Heavy metals <1.07>—Proceed with 2.0 g of Cefcapene Pivoxil Hydrochloride Hydrate according to Method 4, and perform the test. Prepare the control solution with 2.0 mL of Standard Lead Solution (not more than 10 ppm).

(2) Related substance I—Dissolve an amount of Cefcapene Pivoxil Hydrochloride Hydrate, equivalent to about 10 mg (potency), in 2 mL of methanol, add a mixture of water and methanol (1:1) to make 50 mL, and use this solution as the sample solution. Perform the test with 30 μL of the sample solution as directed under Liquid Chromatography <2.01> according to the following conditions, and determine each peak area by the automatic integration method. If necessary, compensate the base-line by performing in the same manner as the test with 30 μL of a mixture of water and methanol (1:1). Measure the amount of the peak other than cefcapene pivoxil by the area percentage method: the amounts of the peaks, having the relative retention times of about 1.5 and about 1.7 to cefcapene pivoxil, are not more than 0.2%, respectively. The amount of the peaks other than the peaks mentioned above is not more than 0.1%, and the total of them is not more than 1.5%.

Operating conditions—

Detector: An ultraviolet absorption photometer (wavelength: 265 nm).

Column: A stainless steel column 4.6 mm in inside diameter and 15 cm in length, packed with octadecylsilanized silica gel for liquid chromatography (5 μm in particle diameter).

Column temperature: A constant temperature of about 20°C.

Mobile phase A: Dissolve 5.99 g of potassium dihydrogen phosphate in water to make 1100 mL. To this solution add a solution prepared by dissolving 1.89 g of tetra-*n*-pentylammonium bromide in methanol to make 1000 mL.

Mobile phase B: A mixture of methanol and water (22:3).

Flowing of mobile phase: Control the gradient by mixing the mobile phases A and B as directed in the following table.

Time after injection of sample (min)	Mobile phase A (vol%)	Mobile phase B (vol%)
0 – 20	98	2
20 – 40	98 → 50	2 → 50
40 – 50	50	50

Flow rate: 0.8 mL per minute.

Time span of measurement: About 2.5 times as long as the retention time of cefcapene pivoxil.

System suitability—

Test for required detectability: To exactly 1 mL of the sample solution add a mixture of water and methanol (1:1) to make 100 mL, and use this solution as the solution for system suitability test. Pipet 1 mL of the solution for system suitability test, and add the mixture of water and methanol (1:1) to make exactly 10 mL. Confirm that the peak area of cefcapene pivoxil obtained with 30 μL of this solution is equivalent to 7 to 13% of that with 30 μL of the solution for system suitability test.

System performance: Dissolve 10 mg of Cefcapene Pivoxil Hydrochloride Hydrate and 10 mg of propyl parahydroxybenzoate in 25 mL of methanol, and add water to make 50 mL. To 5 mL of this solution add the mixture of water and methanol (1:1) to make 50 mL. When the procedure is run with 30 μL of this solution under the above operating conditions, cefcapene pivoxil and propyl parahydroxybenzoate are eluted in this order with the resolution between these peaks being not less than 7.

System repeatability: When the test is repeated 3 times with 30 μL of the solution for system suitability test under the above operating conditions, the relative standard deviation of the peak area of cefcapene pivoxil is not more than 4.0%.

(3) Related substance II—Dissolve an amount of Cefcapene Pivoxil Hydrochloride Hydrate, equivalent to about 2 mg (potency), in *N,N*-dimethylformamide for liquid chromatography to make 20 mL, and use this solution as the sample solution. Perform the test with 20 μL of the sample solution as directed under Liquid Chromatography <2.01> according to the following conditions, and determine each peak area by the automatic integration method: the total area of the peaks which appear earlier than cefcapene pivoxil is not more than 1.7% of the total area of the peaks other than the solvent.

Operating conditions—

Detector: An ultraviolet absorption photometer (wavelength: 280 nm).

Column: A stainless steel column 7.8 mm in inside diameter and 30 cm in length, packed with styrene-divinylbenzene copolymer for liquid chromatography.

Column temperature: A constant temperature of about 25°C.

Mobile phase: A solution of lithium bromide in *N,N*-dimethylformamide for liquid chromatography (13 in 5000).

Flow rate: Adjust so that the retention time of cefcapene pivoxil is about 22 minutes.

Time span of measurement: About 1.8 times as long as the retention time of cefcapene pivoxil.

System suitability—

Test for required detectability: To exactly 1 mL of the sample solution add *N,N*-dimethylformamide for liquid chromatography to make 100 mL, and use this solution as the solution for system suitability test. Pipet 3 mL of the solution for system suitability test, and add *N,N*-dimethylformamide for liquid chromatography to make exactly 10 mL. Confirm that the peak area of cefcapene pivoxil obtained with 20 μL of this solution is equivalent to 20 to 40% of that with 20 μL of the solution for system suitability test.

System performance: When the procedure is run with 20 μL of the sample solution under the above operating conditions, the number of theoretical plates of the peak of cefcapene pivoxil is not less than 12,000.

System repeatability: When the test is repeated 6 times

with 20 μL of the solution for system suitability test under the above operating conditions, the relative standard deviation of the peak areas of cefcapene pivoxil is not more than 4.0%.

Water <2.48> Not less than 2.8% and not more than 3.7% (0.5 g, volumetric titration, back titration).

Assay Weigh accurately an amount of Cefcapene Pivoxil Hydrochloride Hydrate and Cefcapene Pivoxil Hydrochloride RS, equivalent to about 20 mg (potency), and dissolve each in a mixture of water and methanol (1:1) to make exactly 50 mL. Pipet 10 mL each of these solutions, add exactly 10 mL of the internal standard solution and the mixture of water and methanol (1:1) to them to make 50 mL, and use these solutions as the sample solution and the standard solution, respectively. Perform the test with 10 μL each of the sample solution and standard solution as directed under Liquid Chromatography <2.01> according to the following conditions, and calculate the ratios, Q_T and Q_S , of the peak area of cefcapene pivoxil to that of the internal standard.

$$\begin{aligned} \text{Amount } [\mu\text{g (potency)}] \text{ of cefcapene (C}_{17}\text{H}_{19}\text{N}_5\text{O}_6\text{S}_2) \\ = M_S \times Q_T / Q_S \times 1000 \end{aligned}$$

M_S : Amount [mg (potency)] of Cefcapene Pivoxil Hydrochloride RS taken

Internal standard solution—A solution of *p*-benzylphenol in a mixture of water and methanol (1:1) (7 in 4000).

Operating conditions—

Detector: An ultraviolet absorption photometer (wavelength: 265 nm).

Column: A stainless steel column 3.0 mm in inside diameter and 7.5 cm in length, packed with octadecylsilanized silica gel for liquid chromatography (3 μm in particle diameter).

Column temperature: A constant temperature of about 40°C.

Mobile phase: Dissolve 1.56 g of sodium dihydrogenphosphate dihydrate and 1.22 g of sodium 1-decanesulfonate in water to make 1000 mL. To 700 mL of this solution add 300 mL of acetonitrile and 100 mL of methanol.

Flow rate: Adjust so that the retention time of cefcapene pivoxil is about 5 minutes.

System suitability—

System performance: Dissolve 0.2 g of Cefcapene Pivoxil Hydrochloride Hydrate in 10 mL of methanol, and warm in a water bath at 60°C for 20 minutes. After cooling, pipet 1 mL of this solution, and add exactly 10 mL of the internal standard solution and the mixture of water and methanol (1:1) to make 50 mL. When the procedure is run with 10 μL of this solution under the above operating conditions, cefcapene pivoxil, *trans*-cefcapene pivoxil and the internal standard are eluted in this order, the relative retention time of *trans*-cefcapene pivoxil and the internal standard to that of cefcapene pivoxil are about 1.7 and about 2.0, respectively, and the resolution between the peaks of *trans*-cefcapene pivoxil and the internal standard is not less than 1.5.

System repeatability: When the test is repeated 5 times with 10 μL of the standard solution under the above operating conditions, the relative standard deviation of the ratio of the peak area of cefcapene pivoxil to that of the internal standard is not more than 1.0%.

Containers and storage Containers—Tight containers.

Storage—Light-resistant, at a temperature not exceeding 5°C.

Cefcapene Pivoxil Hydrochloride Fine Granules

セフカペン ピボキシル塩酸塩細粒

Cefcapene Pivoxil Hydrochloride Fine Granules contain not less than 90.0% and not more than 110.0% of the labeled potency of cefcapene (C₁₇H₁₉N₅O₆S₂: 453.49).

Method of preparation Prepare as directed under Granules, with Cefcapene Pivoxil Hydrochloride Hydrate.

Identification Powder Cefcapene Pivoxil Hydrochloride Fine Granules. To a portion of the powder, equivalent to 10 mg (potency) of Cefcapene Pivoxil Hydrochloride Hydrate, add 40 mL of methanol, shake vigorously, and add methanol to make 50 mL. To 4 mL of this solution add methanol to make 50 mL, and filter through a membrane filter with a pore size of 0.45 μm . Determine the absorption spectrum of the filtrate as directed under Ultraviolet-visible Spectrophotometry <2.24>: it exhibits a maximum between 264 nm and 268 nm.

Purity (1) Related substances I—Powder Cefcapene Pivoxil Hydrochloride Fine Granules. To a portion of the powder, equivalent to 5 mg (potency) of Cefcapene Pivoxil Hydrochloride Hydrate, add 1 mL of methanol, and shake. Add 25 mL of a mixture of water and methanol (1:1), shake vigorously for 5 minutes, and filter through a membrane filter with a pore size of 0.45 μm . Discard the first 3 mL of the filtrate, and use the subsequent filtrate as the sample solution. Perform the test with 30 μL of the sample solution as directed under Liquid Chromatography <2.01> according to the following conditions. Determine each peak area by the automatic integration method. If necessary, compensate the base-line by performing in the same manner as the test with 30 μL of a mixture of water and methanol (1:1). Calculate the amount of the peaks other than the peak of cefcapene pivoxil by the area percentage method: the amount of the substance, having the relative retention time of about 1.3 to cefcapene pivoxil, is not more than 0.4%, the amount of the *trans*-isomer of cefcapene pivoxil, having the relative retention time of about 1.5, is not more than 1.1%, the amount of the substance other than that mentioned above is not more than 0.3%, and the total amount of these substances is not more than 2.8%.

Operating conditions—

Proceed as directed in the operating conditions in the Purity (2) under Cefcapene Pivoxil Hydrochloride Hydrate.

System suitability—

Proceed as directed in the system suitability in the Purity (2) under Cefcapene Pivoxil Hydrochloride Hydrate.

(2) Related substances II—Powder Cefcapene Pivoxil Hydrochloride Fine Granules. To a portion of the powder, equivalent to 2 mg (potency) of Cefcapene Pivoxil Hydrochloride Hydrate, add 20 mL of *N,N*-dimethylformamide for liquid chromatography, shake vigorously for 10 minutes, and filter through a membrane filter with a pore size of 0.45 μm . Discard the first 3 mL of the filtrate, and use the subsequent filtrate as the sample solution. Perform the test with 20 μL of the sample solution as directed under Liquid Chromatography <2.01> according to the following conditions, and determine each peak area by the automatic integration method: the total area of the peaks eluted before that of cefcapene pivoxil is not more than 4.0% of the total area of all

peaks other than the solvent peak.

Operating conditions—

Proceed as directed in the operating conditions in the Purity (3) under Cefcapene Pivoxil Hydrochloride Hydrate.

System suitability—

Proceed as directed in the system suitability in the Purity (3) under Cefcapene Pivoxil Hydrochloride Hydrate.

Water <2.48> Not more than 1.4% (0.5 g, volumetric titration, back titration). Perform the test without pulverizing the sample, and handling the sample under a relative humidity of less than 30%.

Uniformity of dosage units <6.02> The granules in single-dose packages meet the requirement of the Mass variation test.

Dissolution Being specified separately when the drug is granted approval based on the Law.

Assay Weigh accurately an amount of Cefcapene Pivoxil Hydrochloride Fine Granules, equivalent to about 0.2 g (potency) of and Cefcapene Pivoxil Hydrochloride Hydrate, add 100 mL of the mixture of water and methanol (1:1), shake vigorously for 10 minutes, add the mixture of water and methanol (1:1) to make exactly 200 mL, and centrifuge at 3000 rpm for 5 minutes. Filter the supernatant liquid through a membrane filter with a pore size of 0.45 μm , discard the first 1 mL of the filtrate, pipet 2 mL of the subsequent filtrate, add exactly 5 mL of the internal standard solution and the mixture of water and methanol (1:1) to make 25 mL, and use this solution as the sample solution. Separately, weigh accurately about 20 mg (potency) of Cefcapene Pivoxil Hydrochloride RS, and dissolve in the mixture of water and methanol (1:1) to make exactly 50 mL. Pipet 10 mL of this solution, add exactly 10 mL of the internal standard solution and the mixture of water and methanol (1:1) to make 50 mL, and use this solution as the standard solution. Proceed as directed in the Assay under Cefcapene Pivoxil Hydrochloride Hydrate.

$$\text{Amount [mg (potency)] of cefcapene (C}_{17}\text{H}_{19}\text{N}_5\text{O}_6\text{S}_2) \\ = M_S \times Q_T / Q_S \times 10$$

M_S : Amount [mg (potency)] of Cefcapene Pivoxil Hydrochloride RS taken

Internal standard solution—A solution of *p*-benzylphenol in the mixture of water and methanol (1:1) (7 in 4000).

Containers and storage Containers—Tight containers.
Storage—Light-resistant.

Cefcapene Pivoxil Hydrochloride Tablets

セフカペン ピボキシル塩酸塩錠

Cefcapene Pivoxil Hydrochloride Tablets contain not less than 90.0% and not more than 105.0% of the labeled potency of cefcapene (C₁₇H₁₉N₅O₆S₂: 453.49).

Method of preparation Prepare as directed under Tablets, with Cefcapene Pivoxil Hydrochloride Hydrate.

Identification To an amount of powdered Cefcapene Pivoxil Hydrochloride Tablets, equivalent to about 10 mg (potency) of Cefcapene Pivoxil Hydrochloride Hydrate, add 40 mL of methanol, shake vigorously, and add methanol to make 50 mL. To 4 mL of this solution add methanol to

make 50 mL, filter through a membrane filter with pore size of 0.45 μm , and use the filtrate as the sample solution. Determine the absorption spectrum of the sample solution as directed under Ultraviolet-visible Spectrophotometry <2.24>: it exhibits a maximum between 263 nm and 267 nm.

Purity (1) Related substances I—To an amount of powdered Cefcapene Pivoxil Hydrochloride Tablets, equivalent to about 5 mg (potency) of Cefcapene Pivoxil Hydrochloride Hydrate, add 1 mL of methanol, and shake. Add 25 mL of a mixture of water and methanol (1:1), shake vigorously for 5 minutes, and filter through a membrane filter with pore size of 0.45 μm . Discard the first 3 mL of the filtrate, and use the subsequent filtrate as the sample solution. Perform the test with 30 μL of the sample solution as directed under Liquid Chromatography <2.01> according to the following conditions, and determine each peak area by the automatic integration method. If necessary, proceed with 30 μL of the mixture of water and methanol (1:1) in the same manner as the sample solution to compensate the base line. Calculate the amounts of the peaks other than cefcapene pivoxil by the area percentage method: the amount of the peak, having the relative retention time of about 1.3 to cefcapene pivoxil, is not more than 0.4%, the amount of the peak of cefcapene pivoxil trans-isomer, having the relative retention time of about 1.5, is not more than 0.5%, the amount of the peaks other than the peaks mentioned above are not more than 0.3%, respectively, and the total amount of these peaks is not more than 2.0%.

Operating conditions—

Proceed as directed in the operating conditions in the Purity (2) under Cefcapene Pivoxil Hydrochloride Hydrate.

System suitability—

Proceed as directed in the system suitability in the Purity (2) under Cefcapene Pivoxil Hydrochloride Hydrate.

(2) Related substances II—To an amount of powdered Cefcapene Pivoxil Hydrochloride Tablets, equivalent to 2 mg (potency) of Cefcapene Pivoxil Hydrochloride Hydrate, add 20 mL of *N,N*-dimethylformamide for liquid chromatography, shake vigorously for 10 minutes, and filter through a membrane filter with pore size of 0.45 μm . Discard the first 3 mL of the filtrate, and use the subsequent filtrate as the sample solution. Perform the test with 20 μL of the sample solution as directed under Liquid Chromatography <2.01> according to the following conditions, and determine each peak area by the automatic integration method: the total area of the peaks which are eluted before cefcapene pivoxil is not more than 3.3% of the total area of the peaks other than the solvent peak.

Operating conditions—

Proceed as directed in the operating conditions in the Purity (3) under Cefcapene Pivoxil Hydrochloride Hydrate.

System suitability—

Proceed as directed in the system suitability in the Purity (3) under Cefcapene Pivoxil Hydrochloride Hydrate.

Water <2.48> Not more than 3.9% (0.5 g, volumetric titration, back titration). Powdering of the sample tablets and handling of the powder are performed under the relative humidity of not exceeding 30%.

Uniformity of dosage units <6.02> Perform the Mass variation test, or the Content uniformity test according to the following method: it meets the requirement.

To 1 tablet of Cefcapene Pivoxil Hydrochloride Tablets add 5 mL of water, and shake vigorously for 5 minutes to disintegrate. Add 20 mL of methanol, shake vigorously for 5 minutes, add a mixture of methanol and water (4:1) to make

exactly 50 mL, and centrifuge at 3000 rpm for 5 minutes. Filter the supernatant liquid through a membrane filter with pore size of 0.45 μm , and discard the first 1 mL of the filtrate. Pipet V mL of the subsequent filtrate, equivalent to about 6 mg (potency) of Cefcapene Pivoxil Hydrochloride Hydrate, add exactly 15 mL of the internal standard solution, add a mixture of water and methanol (1:1) to make 75 mL, and use this solution as the sample solution. Then, proceed as directed in the Assay.

$$\begin{aligned} \text{Amount [mg (potency)] of cefcapene (C}_{17}\text{H}_{19}\text{N}_5\text{O}_6\text{S}_2) \\ = M_S \times Q_T/Q_S \times 15/V \end{aligned}$$

M_S : Amount [mg (potency)] of Cefcapene Pivoxil Hydrochloride RS taken

Internal standard solution—A solution of *p*-benzylphenol in a mixture of water and methanol (1:1) (7 in 4000).

Dissolution Being specified separately when the drug is granted approval based on the Law.

Assay To an amount of Cefcapene Pivoxil Hydrochloride Tablets, equivalent to about 0.6 g (potency) of Cefcapene Pivoxil Hydrochloride Hydrate, add 20 mL of water, and shake for 5 minutes to disintegrate. Add 80 mL of methanol, shake vigorously for 5 minutes, add a mixture of methanol and water (4:1) to make exactly 200 mL, and centrifuge at 3000 rpm for 5 minutes. Filter the supernatant liquid through a membrane filter with pore size of 0.45 μm , and discard the first 1 mL of the filtrate. Pipet 2 mL of the subsequent filtrate, add exactly 15 mL of the internal standard solution, add the mixture of water and methanol (1:1) to make 75 mL, and use this solution as the sample solution. Separately, weigh accurately an amount of Cefcapene Pivoxil Hydrochloride RS, equivalent to about 20 mg (potency), and dissolve in the mixture of water and methanol (1:1) to make exactly 50 mL. Pipet 10 mL of this solution, add exactly 10 mL of the internal standard solution, add the mixture of water and methanol (1:1) to make 50 mL, and use this solution as the standard solution. Proceed as directed in the Assay under Cefcapene Pivoxil Hydrochloride Hydrate.

$$\begin{aligned} \text{Amount [mg (potency)] of cefcapene (C}_{17}\text{H}_{19}\text{N}_5\text{O}_6\text{S}_2) \\ = M_S \times Q_T/Q_S \times 30 \end{aligned}$$

M_S : Amount [mg (potency)] of Cefcapene Pivoxil Hydrochloride RS taken

Internal standard solution—A solution of *p*-benzylphenol in the mixture of water and methanol (1:1) (7 in 4000).

Containers and storage Containers—Tight containers.

Cefdinir

セフジニル

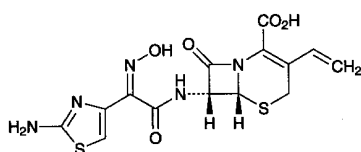

$\text{C}_{14}\text{H}_{13}\text{N}_5\text{O}_5\text{S}_2$: 395.41

(6*R*,7*R*)-7-[(*Z*)-2-(2-Aminothiazol-4-yl)-2-(hydroxyimino)acetylamino]-8-oxo-3-vinyl-5-thia-1-azabicyclo[4.2.0]oct-2-ene-2-carboxylic acid
[91832-40-5]

Cefdinir contains not less than 930 μg (potency) and

not more than 1020 μg (potency) per mg. The potency of Cefdinir is expressed as mass (potency) of cefdinir ($\text{C}_{14}\text{H}_{13}\text{N}_5\text{O}_5\text{S}_2$).

Description Cefdinir occurs as a white to light yellow crystalline powder.

It is practically insoluble in water, in ethanol (95) and in diethyl ether.

It dissolves in 0.1 mol/L phosphate buffer solution (pH 7.0).

Identification (1) Determine the absorption spectra of solutions of Cefdinir and Cefdinir RS in 0.1 mol/L phosphate buffer solution (pH 7.0) (1 in 100,000) as directed under Ultraviolet-visible Spectrophotometry <2.24>, and compare these spectra: both spectra exhibit similar intensities of absorption at the same wavelengths.

(2) Determine the infrared absorption spectra of Cefdinir and Cefdinir RS as directed in the paste method under Infrared Spectrophotometry <2.25>, and compare these spectra: both spectra exhibit similar intensities of absorption at the same wave numbers.

(3) Determine the ^1H spectrum of a solution of Cefdinir in a mixture of deuterated dimethyl sulfoxide for nuclear magnetic resonance spectroscopy and heavy water for nuclear magnetic resonance spectroscopy (4:1) (1 in 10), using tetramethylsilane for nuclear magnetic resonance spectroscopy as an internal reference compound, as directed under Nuclear Magnetic Resonance Spectroscopy <2.21>: it exhibits multiplet signals, A at around δ 5.0 – 6.1 ppm and B at around δ 6.4 – 7.5 ppm. The ratio of integrated intensity of each signal, A:B is about 2:1.

Optical rotation <2.49> $[\alpha]_D^{20}$: $-58 - -66^\circ$ (0.25 g, 0.1 mol/L phosphate buffer solution (pH 7.0), 25 mL, 100 mm).

Purity (1) Heavy metals <1.07>—Proceed with 2.0 g of Cefdinir according to Method 2, and perform the test. Prepare the control solution with 2.0 mL of Standard Lead Solution (not more than 10 ppm).

(2) Related substances—Dissolve about 0.1 g of Cefdinir in 10 mL of 0.1 mol/L phosphate buffer solution (pH 7.0). To 3 mL of this solution add tetramethylammonium hydroxide TS (pH 5.5) to make 20 mL, and use this solution as the sample solution. Perform the test with 10 μL of the sample solution as directed under Liquid Chromatography <2.01> according to the following conditions. Determine each peak area by the automatic integration method, and calculate the amounts of their peaks by the area percentage method: the amount of the peaks, having the relative retention time of about 0.7, about 1.2 and about 1.5 to cefdinir, are not more than 0.7%, not more than 0.3% and not more than 0.8%, respectively, the total amount of the peaks, having the relative retention time of about 0.85, about 0.93, about 1.11 and about 1.14, is not more than 0.4%, and the amount of the peak other than cefdinir and the peaks mentioned above is not more than 0.2%. And the total amount of the peaks other than cefdinir is not more than 3.0%.

Operating conditions—

Detector: An ultraviolet absorption photometer (wavelength: 254 nm).

Column: A stainless steel column 4.6 mm in inside diameter and 15 cm in length, packed with octadecylsilanized silica gel for liquid chromatography (5 μm in particle diameter).

Column temperature: A constant temperature of about 40°C.

Mobile phase A: To 1000 mL of tetramethylammonium hydroxide TS (pH 5.5) add 0.4 mL of 0.1 mol/L disodium dihydrogen ethylenediamine tetraacetate TS.

Mobile phase B: To 500 mL of tetramethylammonium hydroxide TS (pH 5.5) add 300 mL of acetonitrile for liquid chromatography and 200 mL of methanol, and add 0.4 mL of 0.1 mol/L disodium dihydrogen ethylenediamine tetraacetate TS.

Flowing of mobile phase: Control the gradient by mixing the mobile phases A and B as directed in the following table.

Time after injection of sample (min)	Mobile phase A (vol%)	Mobile phase B (vol%)
0 - 2	95	5
2 - 22	95 → 75	5 → 25
22 - 32	75 → 50	25 → 50
32 - 37	50	50

Flow rate: 1.0 mL per minute (the retention time of cefdinir is about 22 minutes).

Time span of measurement: For 37 minutes after injection, beginning after the solvent peak.

System suitability—

Test for required detectability: To 1 mL of the sample solution add tetramethylammonium hydroxide TS (pH 5.5) to make 100 mL, and use this solution as the solution for system suitability test. Pipet 1 mL of the solution for system suitability test, add tetramethylammonium hydroxide TS (pH 5.5) to make exactly 10 mL. Confirm that the peak area of cefdinir obtained with 10 μ L of this solution is equivalent to 7 to 13% of that with 10 μ L of the solution for system suitability test.

System performance: Dissolve 30 mg of Cefdinir RS and 2 mg of cefdinir lactam ring-cleavage lactones in 3 mL of 0.1 mol/L phosphate buffer solution (pH 7.0), add tetramethylammonium hydroxide TS (pH 5.5) to make 20 mL. When the procedure is run with 10 μ L of this solution under the above operating conditions, peak 1 and peak 2 of cefdinir lactam ring-cleavage lactones separated into 4 peaks, cefdinir, peak 3 and peak 4 of remaining cefdinir lactam ring-cleavage lactones are eluted in this order. Relative retention time of peak 3 of cefdinir lactam ring-cleavage lactone to cefdinir is about 1.11. The number of theoretical plates and the symmetry factor of the peak of cefdinir are not less than 7000 and not more than 3.0, respectively.

System repeatability: When the test is repeated 3 times with 10 μ L of the solution for system suitability test under the above operating conditions, the relative standard deviation of the peak areas of cefdinir is not more than 2.0%.

Water <2.48> Not more than 2.0% (1 g, volumetric titration, direct titration. Use a mixture of formamide for water determination and methanol for water determination (2:1) instead of methanol for water determination).

Assay Weigh accurately an amount of Cefdinir and Cefdinir RS equivalent to about 20 mg (potency), dissolve each in 0.1 mol/L phosphate buffer solution (pH 7.0) to make exactly 100 mL, and use these solutions as the sample solution and standard solution. Perform the test with exactly 5 μ L of the sample solution and standard solution as directed under Liquid Chromatography <2.01> according to the following conditions, and determine the peak areas, A_T and A_S , of cefdinir in each solution.

$$\text{Amount } [\mu\text{g (potency)}] \text{ of cefdinir } (\text{C}_{14}\text{H}_{13}\text{N}_5\text{O}_5\text{S}_2) \\ = M_S \times A_T / A_S \times 1000$$

M_S : Amount [mg (potency)] of Cefdinir RS taken

Operating conditions—

Detector: An ultraviolet absorption photometer (wavelength: 254 nm).

Column: A stainless steel column 4.6 mm in inside diameter and 15 cm in length, packed with octadecylsilanized silica gel for liquid chromatography (5 μ m in particle diameter).

Column temperature: A constant temperature of about 40°C.

Mobile phase: To 1000 mL of tetramethylammonium hydroxide TS (pH 5.5) add 0.4 mL of 0.1 mol/L disodium dihydrogen ethylenediamine tetraacetate TS. To 900 mL of this solution add 60 mL of acetonitrile for liquid chromatography and 40 mL of methanol.

Flow rate: Adjust so that the retention time of cefdinir is about 8 minutes.

System suitability—

System performance: Dissolve 2 mg of Cefdinir RS and 5 mg of cefdinir lactam ring-cleavage lactones in 10 mL of 0.1 mol/L phosphate buffer solution, pH 7.0. When the procedure is run with 5 μ L of this solution under the above operating conditions, peak 1 and peak 2 of cefdinir lactam ring-cleavage lactones separated into 4 peaks, cefdinir, peak 3 and peak 4 of remaining cefdinir lactam ring-cleavage lactones are eluted in this order. The resolution between the peak 2 of cefdinir lactam ring-cleavage lactone and that of cefdinir is not less than 1.2. The number of theoretical plates and the symmetry factor of the peak of cefdinir are not less than 2000 and not more than 1.5, respectively.

System repeatability: When the test is repeated 6 times with 5 μ L of the standard solution under the above operating conditions, the relative standard deviation of the peak areas of cefdinir is not more than 1.0%.

Containers and storage Containers—Tight containers.

Storage—Light-resistant.

Cefdinir Capsules

セフジニルカプセル

Cefdinir Capsules contain not less than 90.0% and not more than 110.0% of the labeled potency of cefdinir ($\text{C}_{14}\text{H}_{13}\text{N}_5\text{O}_5\text{S}_2$; 395.41).

Method of preparation Prepare as directed under Capsules, with Cefdinir.

Identification To an amount of the contents of Cefdinir Capsules, equivalent to 10 mg (potency) of Cefdinir, add 100 mL of 0.1 mol/L phosphate buffer solution (pH 7.0), exposure to ultrasonic waves for 1 minute, and filter. To 2 mL of the filtrate add 0.1 mol/L phosphate buffer solution (pH 7.0) to make 20 mL, and determine the absorption spectrum of this solution as directed under Ultraviolet-visible Spectrophotometry <2.24>: it exhibits maxima between 221 nm and 225 nm and between 285 nm and 289 nm.

Uniformity of dosage units <6.02> It meets the requirement of the Mass variation test.

Dissolution <6.10> When the test is performed at 50 revolutions per minute according to the Paddle method using the sinker, using 900 mL of 2nd fluid for dissolution test as the dissolution medium, the dissolution rate of a 50-mg capsule in 30 minutes is not less than 80%, and that of a 100-mg capsule in 45 minutes is not less than 75%.

Start the test with 1 capsule of Cefdinir Capsules, withdraw not less than 20 mL of the medium at the specified

minute after starting the test, and filter through a membrane filter with a pore size not exceeding 0.5 μm . Discard not less than 10 mL of the first filtrate, pipet V mL of the subsequent filtrate, add the dissolution medium to make exactly V' mL so that each mL contains about 56 μg (potency) of Cefdinir, and use this solution as the sample solution. Separately, weigh accurately about 28 mg (potency) of Cefdinir RS, and dissolve in the dissolution medium to make exactly 100 mL. Pipet 4 mL of this solution, add the dissolution medium to make exactly 20 mL, and use this solution as the standard solution. Perform the test with exactly 20 μL each of the sample solution and standard solution as directed under Liquid Chromatography <2.01>, and determine the peak areas, A_T and A_S , of cefdinir in each solution.

Dissolution rate (%) with respect to the labeled amount of cefdinir ($\text{C}_{14}\text{H}_{13}\text{N}_5\text{O}_5\text{S}_2$)

$$= M_S \times A_T/A_S \times V'/V \times 1/C \times 180$$

M_S : Amount [mg (potency)] of Cefdinir RS taken

C : Labeled amount [mg (potency)] of cefdinir ($\text{C}_{14}\text{H}_{13}\text{N}_5\text{O}_5\text{S}_2$) in 1 capsule

Operating conditions—

Proceed as directed in the operating conditions in the Assay under Cefdinir.

System suitability—

System performance: When the procedure is run with 20 μL of the standard solution under the above operating conditions, the number of theoretical plates and the symmetry factor of the peak of cefdinir are not less than 2000 and not more than 2.0, respectively.

System repeatability: When the test is repeated 6 times with 20 μL of the standard solution under the above operating conditions, the relative standard deviation of the peak area of cefdinir is not more than 1.0%.

Assay Weigh accurately not less than 5 Cefdinir Capsules, take out the contents, and powder. Wash the empty capsules with a little amount of diethyl ether, if necessary, allow to stand at a room temperature to vaporize the adhering diethyl ether, and weigh accurately the mass of the capsules to calculate the mass of the contents. Weigh accurately an amount of the contents, equivalent to about 0.1 g (potency) of Cefdinir, add 70 mL of 0.1 mol/L phosphate buffer solution (pH 7.0), shake for 30 minutes, and add 0.1 mol/L phosphate buffer solution (pH 7.0) to make exactly 100 mL. Centrifuge this solution at 3000 revolutions per minute for 10 minutes, pipet 4 mL of the supernatant liquid, add 0.1 mol/L phosphate buffer solution (pH 7.0) to make exactly 20 mL, and use this solution as the sample solution. Separately, weigh accurately an amount of Cefdinir RS, equivalent to about 20 mg (potency), dissolve in 0.1 mol/L phosphate buffer solution (pH 7.0) to make exactly 100 mL, and use this solution as the standard solution. Proceed as directed in the Assay under Cefdinir.

$$\text{Amount [mg (potency)] of cefdinir } (\text{C}_{14}\text{H}_{13}\text{N}_5\text{O}_5\text{S}_2) \\ = M_S \times A_T/A_S \times 5$$

M_S : Amount [mg (potency)] of Cefdinir RS taken

Containers and storage Containers—Tight containers.

Cefdinir Fine Granules

セフジニル細粒

Cefdinir Fine Granules contain not less than 93.0% and not more than 107.0% of the labeled potency of cefdinir ($\text{C}_{14}\text{H}_{13}\text{N}_5\text{O}_5\text{S}_2$; 395.41).

Method of preparation Prepare as directed under Granules, with Cefdinir.

Identification To an amount of Cefdinir Fine Granules, equivalent to 10 mg (potency) of Cefdinir, add 100 mL of 0.1 mol/L phosphate buffer solution (pH 7.0), exposure to ultrasonic waves for 1 minute, and filter. To 2 mL of the filtrate add 0.1 mol/L phosphate buffer solution (pH 7.0) to make 20 mL, and determine the absorption spectrum of this solution as directed under Ultraviolet-visible Spectrophotometry <2.24>: it exhibits maxima between 221 nm and 225 nm and between 285 nm and 289 nm.

Uniformity of dosage units <6.02> The granules in single-dose packages meet the requirement of the Mass variation test.

Dissolution <6.10> When the test is performed at 50 revolutions per minute according to the Paddle method, using 900 mL of 2nd fluid for dissolution test as the dissolution medium, the dissolution rate in 30 minutes of Cefdinir Fine Granules is not less than 75%.

Start the test with an accurate amount of Cefdinir Fine Granules, equivalent to about 0.1 g (potency) of Cefdinir, withdraw not less than about 20 mL of the medium at the specified minute after starting the test, and filter through a membrane filter with a pore size not exceeding 0.5 μm . Discard not less than 10 mL of the first filtrate, and use the subsequent filtrate as the sample solution. Separately, weigh accurately about 28 mg (potency) of Cefdinir RS, and dissolve in the dissolution medium to make exactly 50 mL. Pipet 4 mL of this solution, add the dissolution medium to make exactly 20 mL, and use this solution as the standard solution. Perform the test with exactly 20 μL each of the sample solution and standard solution as directed under Liquid Chromatography <2.01>, and determine the peak areas, A_T and A_S , of cefdinir in each solution.

Dissolution rate (%) with respect to the labeled amount of cefdinir ($\text{C}_{14}\text{H}_{13}\text{N}_5\text{O}_5\text{S}_2$)

$$= M_S/M_T \times A_T/A_S \times 1/C \times 360$$

M_S : Amount [mg (potency)] of Cefdinir RS taken

M_T : Amount (g) of Cefdinir Fine Granules taken

C : Labeled amount [mg (potency)] of cefdinir ($\text{C}_{14}\text{H}_{13}\text{N}_5\text{O}_5\text{S}_2$) in 1 g

Operating conditions—

Proceed as directed in the operating conditions in the Assay under Cefdinir.

System suitability—

System performance: When the procedure is run with 20 μL of the standard solution under the above operating conditions, the number of theoretical plates and the symmetry factor of the peak of cefdinir are not less than 2000 and not more than 2.0, respectively.

System repeatability: When the test is repeated 6 times with 20 μL of the standard solution under the above operating conditions, the relative standard deviation of the peak area of cefdinir is not more than 1.0%.

Assay Powder, if necessary, and weigh accurately an amount of Cefdinir Fine Granules, equivalent to about 0.1 g (potency) of Cefdinir, add 70 mL of 0.1 mol/L phosphate buffer solution (pH 7.0), shake for 30 minutes, and add 0.1 mol/L phosphate buffer solution (pH 7.0) to make exactly 100 mL. Centrifuge at 3000 revolutions per minute for 10 minutes, pipet 4 mL of the supernatant liquid, add 0.1 mol/L phosphate buffer solution (pH 7.0) to make 20 mL, and use this solution as the sample solution. Separately, weigh accurately an amount of Cefdinir RS, equivalent to about 20 mg (potency), dissolve in 0.1 mol/L phosphate buffer solution (pH 7.0) to make exactly 100 mL, and use this solution as the standard solution. Proceed as directed in the Assay under Cefdinir.

$$\begin{aligned} & \text{Amount [mg (potency)] of cefdinir (C}_{14}\text{H}_{13}\text{N}_5\text{O}_5\text{S}_2) \\ & = M_S \times A_T/A_S \times 5 \end{aligned}$$

M_S : Amount [mg (potency)] of Cefdinir RS taken

Containers and storage Containers—Tight containers.
Storage—Light-resistant.

Cefditoren Pivoxil

セフジトレン ピボキシル

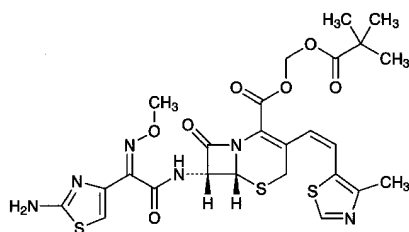

$\text{C}_{25}\text{H}_{28}\text{N}_6\text{O}_7\text{S}_3$: 620.72

2,2-Dimethylpropanoyloxymethyl (6*R*,7*R*)-7-[(*Z*)-2-(2-aminothiazol-4-yl)-2-(methoxyimino)acetyl-amino]-3-[(1*Z*)-2-(4-methylthiazol-5-yl)ethenyl]-8-oxo-5-thia-1-azabicyclo[4.2.0]oct-2-ene-2-carboxylate
[117467-28-4]

Cefditoren Pivoxil contains not less than 770 μg (potency) and not more than 820 μg (potency) per mg, calculated on the anhydrous basis. The potency of Cefditoren Pivoxil is expressed as mass (potency) of cefditoren ($\text{C}_{19}\text{H}_{18}\text{N}_6\text{O}_5\text{S}_3$; 506.58).

Description Cefditoren Pivoxil occurs as a light yellow-white to light yellow crystalline powder.

It is sparingly soluble in methanol, slightly soluble in acetonitrile and in ethanol (95), very slightly soluble in diethylether and practically insoluble in water.

It dissolves in dilute hydrochloric acid.

Identification (1) Dissolve 5 mg of Cefditoren Pivoxil in 3 mL of hydroxylammonium chloride-ethanol TS, allow to stand for 5 minutes, add 1 mL of acidic ammonium iron (III) sulfate TS and shake: a red-brown color develops.

(2) Dissolve 1 mg of Cefditoren Pivoxil in 1 mL of dilute hydrochloric acid and 4 mL of water, add 3 drops of sodium nitrite TS under ice-cooling, shake, and allow to stand for 2 minutes. Then add 1 mL of ammonium amidosulfate TS, shake well, and allow to stand for 1 minute, and add 1 mL of *N,N*-diethyl-*N'*-1-naphthylethylenediamine oxalate TS: a purple color develops.

(3) Determine the absorption spectrum of a solution of Cefditoren Pivoxil in methanol (1 in 50,000) as directed

under Ultraviolet-visible Spectrophotometry <2.24>, and compare the spectrum with the Reference Spectrum or the spectrum of a solution of Cefditoren Pivoxil RS prepared in the same manner as the sample solution: both spectra exhibit similar intensities of absorption at the same wavelengths.

(4) Determine the ^1H spectrum of a solution of Cefditoren Pivoxil in deuterated chloroform for nuclear magnetic resonance spectroscopy (1 in 50), using tetramethylsilane for nuclear magnetic resonance spectroscopy as an internal reference compound, as directed under Nuclear Magnetic Resonance Spectroscopy <2.21>: it exhibits singlet signals A, B and C, at around δ 1.1 ppm, at around δ 2.4 ppm and at around δ 4.0 ppm, doublet signals D and E, at around δ 6.4 ppm and at around δ 6.7 ppm, and a singlet signal F at around δ 8.6 ppm. The ratio of integrated intensity of each signal A:B:C:D:E:F, is about 9:3:3:1:1:1.

Absorbance <2.24> $E_{1\text{cm}}^{1\%}$ (231 nm): 340 – 360 (50 mg, methanol, 2500 mL).

Optical rotation <2.49> $[\alpha]_D^{20}$: –45 – –52° (50 mg, methanol, 10 mL, 100 mm).

Purity (1) Heavy metals <1.07>—Proceed with 2.0 g of Cefditoren Pivoxil according to Method 2, and perform the test. Prepare the control solution with 2.0 mL of Standard Lead Solution (not more than 10 ppm).

(2) Related substances—Being specified separately when the drug is granted approval based on the Law.

Water <2.48> Not more than 1.5% (0.5 g, volumetric titration, direct titration).

Residue on ignition Being specified separately when the drug is granted approval based on the Law.

Assay Conduct this procedure using light-resistant vessels. Weigh accurately an amount of Cefditoren Pivoxil and Cefditoren Pivoxil RS, equivalent to about 40 mg (potency), dissolve in 40 mL of acetonitrile, add exactly 10 mL each of the internal standard solution, and add acetonitrile to make 100 mL, and use these solutions as the sample solution and standard solution. Perform the test with 10 μL each of the sample solution and standard solution as directed under Liquid Chromatography <2.01> according to the following conditions, and calculate the ratios, Q_T and Q_S , of the peak area of cefditoren pivoxil to that of the internal standard.

$$\begin{aligned} & \text{Amount } [\mu\text{g (potency)] of cefditoren (C}_{19}\text{H}_{18}\text{N}_6\text{O}_5\text{S}_3) \\ & = M_S \times Q_T/Q_S \times 1000 \end{aligned}$$

M_S : Amount [mg (potency)] of Cefditoren Pivoxil RS taken

Internal standard solution—A solution of propyl *p*-hydroxybenzoate in acetonitrile (1 in 200).

Operating conditions—

Detector: An ultraviolet absorption photometer (wavelength: 230 nm).

Column: A stainless steel column 4.6 mm in inside diameter and 25 cm in length, packed with octadecylsilanized silica gel for liquid chromatography (5 μm in particle diameter).

Column temperature: A constant temperature of about 25°C.

Mobile phase: Dissolve 1.58 g of ammonium formate in 900 mL of water, adjust to pH 6.0 with diluted formic acid (1 in 250), and add water to make 1000 mL. To 450 mL of this solution add 275 mL of acetonitrile and 275 mL of methanol.

Flow rate: Adjust so that the retention time of cefditoren pivoxil is about 15 minutes.

System suitability—

System performance: When the procedure is run with 10 μL of the standard solution under the above operating conditions, the internal standard and cefditoren pivoxil are eluted in this order with the resolution between these peaks being not less than 5.

System repeatability: When the test is repeated 5 times with 10 μL of the standard solution under the above operating conditions, the relative standard deviation of the ratios of the peak area of cefditoren pivoxil to that of the internal standard is not more than 1.0%.

Containers and storage Containers—Tight containers.

Storage—Light-resistant.

Cefditoren Pivoxil Fine Granules

セフジトレン ピボキシル細粒

Cefditoren Pivoxil Fine Granules contain not less than 90.0% and not more than 110.0% of the labeled potency of cefditoren ($\text{C}_{19}\text{H}_{18}\text{N}_6\text{O}_5\text{S}_3$; 506.58).

Method of preparation Prepare as directed under Granules, with Cefditoren Pivoxil.

Identification To an amount of powdered Cefditoren Pivoxil Fine Granules, equivalent to 0.1 g (potency) of Cefditoren Pivoxil, add 10 mL of acetonitrile, shake vigorously, and filter. To 1 mL of the filtrate add acetonitrile to make 50 mL. To 1 mL of this solution add acetonitrile to make 20 mL, and determine the absorption spectrum of this solution as directed under Ultraviolet-visible Spectrophotometry <2.24>: it exhibits a maximum between 230 nm and 234 nm.

Purity Related substances—Being specified separately when the drug is granted approval based on the Law.

Loss on drying <2.41> Not more than 4.5% (0.5 g, reduced pressure not exceeding 0.67 kPa, 60°C, 3 hours).

Uniformity of dosage units <6.02> The granules in single-dose packages meet the requirement of the Mass variation test.

Dissolution <6.10> When the test is performed at 50 revolutions per minute according to the Paddle method, using 900 mL of 1st fluid for dissolution test as the dissolution medium, the dissolution rate in 15 minutes of Cefditoren Pivoxil Fine Granules is not less than 80%.

Start the test with an accurately weighed amount of Cefditoren Pivoxil Fine Granules, equivalent to about 0.1 g (potency) of Cefditoren Pivoxil, withdraw not less than 20 mL of the medium at the specified minute after starting the test, and filter through a membrane filter with a pore size not exceeding 0.45 μm . Discard not less than 10 mL of the first filtrate, pipet 2 mL of the subsequent filtrate, add water to make exactly 20 mL, and use this solution as the sample solution. Separately, weigh accurately an amount of Cefditoren Pivoxil RS, equivalent to about 22 mg (potency), dissolve in 20 mL of diluted acetonitrile (3 in 4), and add the dissolution medium to make exactly 200 mL. Pipet 2 mL of this solution, add water to make exactly 20 mL, and use this solution as the standard solution. Determine the absorbances, A_T and A_S , at 272 nm of the sample solution and standard solution as directed under Ultraviolet-visible Spectrophotometry <2.24>, using water as the control.

Dissolution rate (%) with respect to the labeled amount of cefditoren pivoxil ($\text{C}_{25}\text{H}_{28}\text{N}_6\text{O}_7\text{S}_3$)

$$= M_S/M_T \times A_T/A_S \times 1/C \times 450$$

M_S : Amount [mg(potency)] of Cefditoren Pivoxil RS taken

M_T : Amount (g) of Cefditoren Pivoxil Fine Granules taken

C : Labeled amount [mg(potency)] of cefditoren pivoxil ($\text{C}_{25}\text{H}_{28}\text{N}_6\text{O}_7\text{S}_3$) in 1 g

Assay Conduct this procedure using light-resistant vessels. Weigh accurately an amount of powdered Cefditoren Pivoxil Fine Granules, equivalent to about 40 mg (potency) of Cefditoren Pivoxil, add 70 mL of diluted acetonitrile (3 in 4), and shake vigorously. To this solution add exactly 10 mL of the internal standard solution, then add acetonitrile to make 100 mL, filter, and use the filtrate as the sample solution. Separately, weigh accurately an amount of Cefditoren Pivoxil RS, equivalent to about 20 mg (potency), dissolve in 20 mL of acetonitrile, add exactly 5 mL of the internal standard solution, then add acetonitrile to make 50 mL, and use this solution as the standard solution. Proceed as directed in the Assay under Cefditoren Pivoxil.

Amount [mg (potency)] of cefditoren ($\text{C}_{19}\text{H}_{18}\text{N}_6\text{O}_5\text{S}_3$)

$$= M_S \times Q_T/Q_S \times 2$$

M_S : Amount [mg (potency)] of Cefditoren Pivoxil RS taken

Internal standard solution—A solution of propyl parahydroxybenzoate in acetonitrile (1 in 200).

Containers and storage Containers—Tight containers.

Storage—Light-resistant.

Cefditoren Pivoxil Tablets

セフジトレン ピボキシル錠

Cefditoren Pivoxil Tablets contain not less than 90.0% and not more than 110.0% of the labeled potency of cefditoren ($\text{C}_{19}\text{H}_{18}\text{N}_6\text{O}_5\text{S}_3$; 506.58).

Method of preparation Prepare as directed under Tablets, with Cefditoren Pivoxil.

Identification To an amount of powdered Cefditoren Pivoxil Tablets, equivalent to 35 mg (potency) of Cefditoren Pivoxil, add 100 mL of methanol, shake, and filter. To 5 mL of the filtrate add methanol to make 100 mL, and determine the absorption spectrum of this solution as directed under Ultraviolet-visible Spectrophotometry <2.24>: it exhibits a maximum between 229 nm and 233 nm.

Purity Related substances—Being specified separately when the drug is granted approval based on the Law.

Loss on drying <2.41> Not more than 4.0% (0.5 g, reduced pressure not exceeding 0.67 kPa, 60°C, 3 hours).

Uniformity of dosage units <6.02> Perform the Mass variation test, or the Content uniformity test according to the following method: it meets the requirement.

Conduct this procedure using light-resistant vessels. To 1 tablet of Cefditoren Pivoxil Tablets add 12.5 mL of the 1st fluid for disintegration test, shake vigorously, add about 25 mL of acetonitrile, shake again, and add acetonitrile to make exactly 50 mL. Pipet V mL of this solution, equivalent to about 20 mg (potency) of Cefditoren Pivoxil, add exactly

5 mL of the internal standard solution, then add diluted acetonitrile (3 in 4) to make 50 mL, filter, and use the filtrate as the sample solution. Separately, weigh accurately an amount of Cefditoren Pivoxil RS, equivalent to about 20 mg (potency), dissolve in 20 mL of acetonitrile, add exactly 5 mL of the internal standard solution, then add acetonitrile to make 50 mL, and use this solution as the standard solution. Proceed as directed in the Assay under Cefditoren Pivoxil.

$$\text{Amount [mg (potency)] of cefditoren (C}_{19}\text{H}_{18}\text{N}_6\text{O}_5\text{S}_3) \\ = M_S \times Q_T/Q_S \times 50/V$$

M_S : Amount [mg (potency)] of Cefditoren Pivoxil RS taken

Internal standard solution—A solution of propyl parahydroxybenzoate in acetonitrile (1 in 200).

Dissolution <6.10> When the test is performed at 50 revolutions per minute according to the Paddle method, using 900 mL of 1st fluid for dissolution test as the dissolution medium, the dissolution rate in 20 minutes of Cefditoren Pivoxil Tablets is not less than 85%.

Start the test with 1 tablet of Cefditoren Pivoxil Tablets, withdraw not less than 20 mL of the medium at the specified minute after starting the test, and filter through a membrane filter with a pore size not exceeding 0.45 μm . Discard not less than 10 mL of the first filtrate, pipet V mL of the subsequent filtrate, add water to make exactly V' mL so that each mL contains about 11 μg (potency) of Cefditoren Pivoxil, and use this solution as the sample solution. Separately, weigh accurately an amount of Cefditoren Pivoxil RS, equivalent to about 22 mg (potency), dissolve in 20 mL of diluted acetonitrile (3 in 4), then add the dissolution medium to make exactly 200 mL. Pipet 2 mL of this solution, add water to make exactly 20 mL, and use this solution as the standard solution. Determine the absorbances, A_T and A_S , at 272 nm of the sample solution and standard solution as directed under Ultraviolet-visible Spectrophotometry <2.24> using water as the control.

$$\text{Dissolution rate (\%)} \text{ with respect to the labeled amount} \\ \text{of cefditoren pivoxil (C}_{25}\text{H}_{28}\text{N}_6\text{O}_7\text{S}_3) \\ = M_S \times A_T/A_S \times V'/V \times 1/C \times 45$$

M_S : Amount [mg (potency)] of Cefditoren Pivoxil RS taken

C : Labeled amount [mg (potency)] of cefditoren pivoxil (C₂₅H₂₈N₆O₇S₃) in 1 tablet

Assay Conduct this procedure using light-resistant vessels. To an amount of Cefditoren Pivoxil Tablets, equivalent to 0.5 g (potency) of Cefditoren Pivoxil, add 63 mL of the 1st fluid for disintegration test, shake vigorously, add about 125 mL of acetonitrile, shake again, and add acetonitrile to make exactly 250 mL. Pipet 10 mL of this solution, add exactly 5 mL of the internal standard solution, then add diluted acetonitrile (3 in 4) to make 50 mL, filter, and use the filtrate as the sample solution. Separately, weigh accurately an amount of Cefditoren Pivoxil RS, equivalent to about 20 mg (potency), dissolve in 20 mL of acetonitrile, add exactly 5 mL of the internal standard solution, then add acetonitrile to make 50 mL, and use this solution as the standard solution. Proceed as directed in the Assay under Cefditoren Pivoxil.

$$\text{Amount [mg (potency)] of cefditoren (C}_{19}\text{H}_{18}\text{N}_6\text{O}_5\text{S}_3) \\ = M_S \times Q_T/Q_S \times 25$$

M_S : Amount [mg (potency)] of Cefditoren Pivoxil RS taken

Internal standard solution—A solution of propyl parahydroxybenzoate in acetonitrile (1 in 200).

droxybenzoate in acetonitrile (1 in 200).

Containers and storage Containers—Tight containers.

Cefepime Dihydrochloride Hydrate

セフェピム塩酸塩水和物

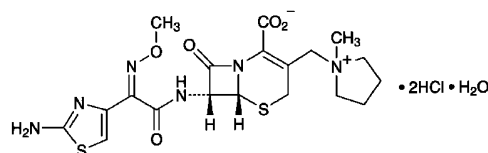

C₁₉H₂₄N₆O₅S₂·2HCl·H₂O: 571.50

(6*R*,7*R*)-7-[(*Z*)-2-(2-Aminothiazol-4-yl)-2-(methoxyimino)acetylamino]-3-(1-methylpyrrolidinium-1-ylmethyl)-8-oxo-5-thia-1-azabicyclo[4.2.0]oct-2-ene-2-carboxylate dihydrochloride monohydrate
[123171-59-5]

Cefepime Dihydrochloride Hydrate contains not less than 835 μg (potency) and not more than 886 μg (potency) per mg, calculated on the anhydrous basis. The potency of Cefepime Dihydrochloride Hydrate is expressed as mass (potency) of cefepime (C₁₉H₂₄N₆O₅S₂: 480.56).

Description Cefepime Dihydrochloride Hydrate occurs as a white to yellowish white, crystals or crystalline powder.

It is freely soluble in water and in methanol, and slightly soluble in ethanol (95), and practically insoluble in diethyl ether.

Identification (1) Dissolve 0.02 g of Cefepime Dihydrochloride Hydrate in 2 mL of water, add 1 mL of a solution of hydroxylammonium chloride (1 in 10) and 2 mL of sodium hydroxide TS, allow to stand for 5 minutes, then add 3 mL of 1 mol/L hydrochloric acid TS and 3 drops of iron (III) chloride TS: a red-brown color develops.

(2) Determine the absorption spectra of solutions (1 in 20,000) of Cefepime Dihydrochloride Hydrate and Cefepime Dihydrochloride RS as directed under Ultraviolet-visible Spectrophotometry <2.24>, and compare these spectra: both spectra exhibit similar intensities of absorption at the same wavelengths.

(3) Determine the infrared absorption spectra of Cefepime Dihydrochloride Hydrate and Cefepime Dihydrochloride RS as directed in the potassium bromide disk method under Infrared Spectrophotometry <2.25>, and compare these spectra: both spectra exhibit similar intensities of absorption at the same wave numbers.

(4) Determine the ¹H spectrum of a solution of Cefepime Dihydrochloride Hydrate in heavy water for nuclear magnetic resonance spectroscopy (1 in 10) as directed under Nuclear Magnetic Resonance Spectroscopy <2.21>, using sodium 3-trimethylsilylpropionate-*d*₄ for nuclear magnetic resonance spectroscopy as an internal reference compound: it exhibits single signals, A and B, at around δ 3.1 ppm and at around δ 7.2 ppm, respectively, and the ratio of integrated intensity of each signal, A:B, is about 3:1.

(5) Dissolve 15 mg of Cefepime Dihydrochloride Hydrate in 5 mL of water, and add 2 drops of silver nitrate TS: a white turbidity is produced.

Absorbance <2.24> $E_{1\text{cm}}^{1\%}$ (259 nm): 310 – 340 (50 mg calculated on the anhydrous basis, water, 1000 mL).

Optical rotation <2.49> $[\alpha]_D^{20}$: +39 – +47° (60 mg calculated on the anhydrous basis, water, 20 mL, 100 mm).

pH <2.54> Dissolve 0.1 g of Cefepime Dihydrochloride Hydrate in 10 mL of water: the pH of this solution is between 1.6 and 2.1.

Purity (1) Clarity and color of solution—Dissolve 0.5 g of Cefepime Dihydrochloride Hydrate in 5 mL of a solution of L-arginine (3 in 50): the solution is clear and has no more color than Matching Fluid H.

(2) Heavy metals <1.07>—Proceed with 1.0 g of Cefepime Dihydrochloride Hydrate according to Method 2, and perform the test. Prepare the control solution with 2.0 mL of Standard Lead Solution (not more than 20 ppm).

(3) *N*-Methylpyrrolidine—Weigh accurately an amount of Cefepime Dihydrochloride Hydrate equivalent to about 80 mg (potency), dissolve in diluted nitric acid (2 in 3125) to make exactly 10 mL, and use this solution as the sample solution. Separately, put 30 mL of water in a 100-mL volumetric flask, weigh accurately the mass of flask, then add about 0.125 g of *N*-methylpyrrolidine, weigh accurately the mass of the flask again, and add water to make exactly 100 mL. Pipet 4 mL of this solution, add diluted nitric acid (2 in 3125) to make exactly 100 mL, and use this solution as the standard solution. Perform the test with exactly 100 μ L each of the sample solution and standard solution as directed under Liquid Chromatography <2.01> according to the following conditions, and determine the peak areas, A_T and A_S , of *N*-methylpyrrolidine by the automatic integration method. Calculate the amount of *N*-methylpyrrolidine per 1 mg (potency) of Cefepime Dihydrochloride Hydrate by the following equation: not more than 0.5%. The sample solution must be tested within 20 minutes after preparation.

$$\begin{aligned} &\text{Amount (\%)} \text{ of } N\text{-methylpyrrolidine} \\ &= (M_S \times f) / M_T \times A_T / A_S \times 1/250 \end{aligned}$$

M_S : Amount (mg) of *N*-methylpyrrolidine taken

M_T : Amount [mg (potency)] of Cefepime Dihydrochloride Hydrate taken

f : Purity (%) of *N*-methylpyrrolidine

Operating conditions—

Detector: An electric conductivity detector.

Column: A plastic tube 4.6 mm in inside diameter and 5 cm in length, packed with hydrophilic silica gel for liquid chromatography carrying sulfonic acid groups having the exchange capacity of about 0.3 meq per g (5 μ m in particle diameter).

Column temperature: A constant temperature of about 35°C.

Mobile phase: To 990 mL of diluted nitric acid (2 in 3125) add 10 mL of acetonitrile.

Flow rate: 1.0 mL per minute.

System suitability—

System performance: To 20 mL of a solution of sodium chloride (3 in 1000) add 0.125 g of *N*-methylpyrrolidine, and add water to make 100 mL. To 4 mL of this solution add diluted nitric acid (2 in 3125) to make 100 mL. When the procedure is run with 100 μ L of this solution under the above operating conditions, sodium and *N*-methylpyrrolidine are eluted in this order with the resolution between these peaks being not less than 2.0.

System repeatability: When the test is repeated 5 times with 100 μ L of the standard solution under the above operating conditions, the relative standard deviation of the peak areas of *N*-methylpyrrolidine is not more than 4.0%.

(4) Related substances—Dissolve about 0.1 g of

Cefepime Dihydrochloride Hydrate in the mobile phase A to make 50 mL, and use this solution as the sample solution. Perform the test with 5 μ L of the sample solution as directed under Liquid Chromatography <2.01> according to the following conditions, and determine the area of each peak by the automatic integration method. Calculate the total amount of the peaks other than cefepime by the area percentage method: not more than 0.5%.

Operating conditions—

Detector: An ultraviolet absorption photometer (wavelength: 254 nm).

Column: A stainless steel column 4.6 mm in inside diameter and 25 cm in length, packed with octadecylsilanized silica gel for liquid chromatography (10 μ m in particle diameter).

Column temperature: A constant temperature of about 25°C.

Mobile phase A: Dissolve 0.57 g of ammonium dihydrogenphosphate in 1000 mL of water.

Mobile phase B: Acetonitrile.

Flowing of mobile phase: Control the gradient by mixing the mobile phases A and B as directed in the following table.

Time after injection of the sample (min)	Mobile phase A (vol%)	Mobile phase B (vol%)
0 – 25	100 → 75	0 → 25

Flow rate: Adjust so that the retention time of cefepime is about 9.5 minutes.

Time span of measurement: About 2.5 times as long as the retention time of cefepime.

System suitability—

Test for required detectability: To 1 mL of the sample solution add the mobile phase A to make 10 mL, and use this solution as the solution for system suitability test. To 1 mL of the solution for system suitability test add the mobile phase A to make 10 mL, and use this solution as the solution for test for required detectability. Pipet 1 mL of the solution for test for required detectability, add the mobile phase A to make exactly 10 mL. Conform that the peak area of cefepime obtained with 5 μ L of this solution is equivalent to 7 to 13% of that with 5 μ L of the solution for test for required detectability.

System performance: When the procedure is run with 5 μ L of the solution for system suitability test under the above operating conditions, the number of theoretical plates of the peak of cefepime is not less than 6000.

System repeatability: When the test is repeated 3 times with 5 μ L of the solution for system suitability test under the above operating conditions, the relative standard deviation of the peak areas of cefepime is not more than 2.0%.

Water <2.48> Not less than 3.0% and not more than 4.5% (Weigh accurately about 50 mg of Cefepime Dihydrochloride Hydrate, dissolve in exactly 2 mL of methanol for water determination and perform the test with exactly 0.5 mL of this solution; coulometric titration).

Residue on ignition <2.44> Not more than 0.1% (1 g).

Bacterial endotoxins <4.01> Less than 0.04 EU/mg (potency).

Assay Weigh accurately an amount of Cefepime Dihydrochloride Hydrate and Cefepime Dihydrochloride RS, equivalent to about 60 mg (potency), dissolve in the mobile phase to make exactly 50 mL, and use these solutions as the sample solution and the standard solution, respectively. Perform the

test with exactly 10 μL each of the sample solution and standard solution as directed under Liquid Chromatography <2.01> according to the following conditions, and determine the peak areas, A_T and A_S , of cefepime in each solution.

$$\text{Amount } [\mu\text{g (potency)}] \text{ of cefepime (C}_{19}\text{H}_{24}\text{N}_6\text{O}_5\text{S}_2) \\ = M_S \times A_T / A_S \times 1000$$

M_S : Amount [mg (potency)] of Cefepime Dihydrochloride RS taken

Operating conditions—

Detector: An ultraviolet absorption photometer (wavelength: 254 nm).

Column: A stainless steel column 3.9 mm in inside diameter and 30 cm in length, packed with octadecylsilanized silica gel for liquid chromatography (10 μm in particle diameter).

Column temperature: A constant temperature of about 40°C.

Mobile phase: Adjust a solution of sodium 1-pentanesulfonate (261 in 100,000) to pH 3.4 with acetic acid (100), then adjust this solution to pH 4.0 with a solution of potassium hydroxide (13 in 20). To 950 mL of this solution add 50 mL of acetonitrile.

Flow rate: Adjust so that the retention time of cefepime is about 8 minutes.

System suitability—

System performance: When the procedure is run with 10 μL of the standard solution under the above operating conditions, the number of theoretical plates of the peak of cefepime is not less than 1500.

System repeatability: When the test is repeated 5 times with 10 μL of the standard solution under the above operating conditions, the relative standard deviation of the peak areas of cefepime is not more than 2.0%.

Containers and storage Containers—Hermetic containers.

Storage—Light-resistant.

Cefepime Dihydrochloride for Injection

注射用セフェピム塩酸塩

Cefepime Dihydrochloride for Injection is a preparation for injection, which is dissolved before use.

It contains not less than 95.0% and not more than 110.0% of the labeled potency of cefepime (C₁₉H₂₄N₆O₅S₂: 480.56).

Method of preparation Prepare as directed under Injections, with Cefepime Dihydrochloride Hydrate.

Description Cefepime Dihydrochloride for Injection occurs as a white to pale yellow powder.

Identification (1) Dissolve 40 mg of Cefepime Dihydrochloride in 2 mL of water, add 1 mL of a solution of hydroxylammonium chloride (1 in 10) and 2 mL of sodium hydroxide TS, allow to stand for 5 minutes, then add 3 mL of 1 mol/L hydrochloric acid TS and 3 drops of iron (III) chloride TS: a red-brown color develops.

(2) Determine the absorption spectrum of a solution of Cefepime Dihydrochloride for Injection (1 in 12,500) as directed under Ultraviolet-visible Spectrophotometry <2.24>: it exhibits maxima between 233 nm and 237 nm and between 255 nm and 259 nm.

pH <2.54> The pH of a solution obtained by dissolving an

amount of Cefepime Dihydrochloride for Injection, equivalent to 0.5 g (potency) of Cefepime Dihydrochloride Hydrate, in 5 mL of water is between 4.0 and 6.0.

Purity (1) Clarity and color of solution—Dissolve an amount of Cefepime Dihydrochloride for Injection, equivalent to 0.5 g (potency) of Cefepime Dihydrochloride Hydrate, in 5 mL of water: the solution is clear and colorless or light yellow. The color is not darker than Matching Fluid I.

(2) *N*-Methylpyrrolidine—Weigh accurately an amount of Cefepime Dihydrochloride for Injection, equivalent to about 0.2 g (potency) of Cefepime Dihydrochloride Hydrate, dissolve in diluted nitric acid (2 in 625) to make exactly 20 mL, and use this solution as the sample solution. Separately, transfer 30 mL of water into a 100-mL volumetric flask, weigh accurately the mass of the flask, add about 0.125 g of *N*-methylpyrrolidine, then weigh accurately the mass, and add water to make exactly 100 mL. Pipet 4 mL of this solution, add diluted nitric acid (2 in 3125) to make exactly 100 mL, and use this solution as the standard solution. Perform the test with exactly 100 μL each of the sample solution and standard solution as directed under Liquid Chromatography <2.01> according to the following conditions, and determine the peak areas of *N*-methylpyrrolidine, A_T and A_S , by the automatic integration method within 20 minutes after the sample solution is prepared. Calculate the amount of *N*-methylpyrrolidine per mg (potency) of Cefepime Dihydrochloride for Injection by the following formula: not more than 1.0%.

$$\text{Amount (\%)} \text{ of } N\text{-methylpyrrolidine} \\ = (M_S \times f) / M_T \times A_T / A_S \times 1/125$$

M_S : Amount (mg) of *N*-methylpyrrolidine taken

M_T : Amount [mg (potency)] of Cefepime Dihydrochloride for Injection taken

f : Purity (%) of *N*-methylpyrrolidine

Operating conditions—

Proceed as directed in the operating conditions in the Purity (3) under Cefepime Dihydrochloride Hydrate.

System suitability—

Proceed as directed in the system suitability in the Purity (3) under Cefepime Dihydrochloride Hydrate.

Water <2.48> Not more than 4.0% (Weigh accurately about 50 mg of Cefepime Dihydrochloride for Injection, dissolve in exactly 2 mL of methanol for water determination, and perform the test with exactly 0.5 mL of this solution: coulometric titration).

Bacterial endotoxins <4.01> Less than 0.06 EU/mg (potency).

Uniformity of dosage units <6.02> It meets the requirement of the Mass variation test.

Foreign insoluble matter <6.06> Perform the test according to Method 2: it meets the requirement.

Insoluble particulate matter <6.07> It meets the requirement.

Sterility <4.06> Perform the test according to the Membrane filtration method: it meets the requirement.

Assay Weigh accurately the mass of the contents of not less than 10 Cefepime Dihydrochloride for Injection. Weigh accurately an amount of the content, equivalent to about 60 mg (potency) of Cefepime Dihydrochloride Hydrate, dissolve in the mobile phase to make exactly 50 mL, and use this solution as the sample solution. Separately, weigh accu-

rately an amount of Cefixime Dihydrochloride RS, equivalent to about 60 mg (potency), dissolve in the mobile phase to make exactly 50 mL, and use this solution as the standard solution. Proceed as directed in the Assay under Cefixime Dihydrochloride Hydrate.

$$\begin{aligned} \text{Amount } [\mu\text{g (potency)}] \text{ of cefixime (C}_{19}\text{H}_{24}\text{N}_6\text{O}_5\text{S}_2) \\ = M_S \times A_T/A_S \times 1000 \end{aligned}$$

M_S : Amount [mg (potency)] of Cefixime Dihydrochloride RS taken

Containers and storage Containers—Hermetic containers.
Storage—Light-resistant.

Cefixime Hydrate

セフィキシム水和物

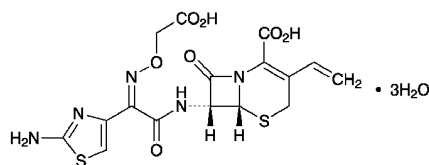

$\text{C}_{16}\text{H}_{15}\text{N}_5\text{O}_7\text{S}_2 \cdot 3\text{H}_2\text{O}$: 507.50
(6*R*,7*R*)-7-[(*Z*)-2-(2-Aminothiazol-4-yl)-2-(carboxymethoxyimino)acetyl]amino-8-oxo-3-vinyl-5-thia-1-azabicyclo[4.2.0]oct-2-ene-2-carboxylic acid trihydrate
[125110-14-7]

Cefixime Hydrate contains not less than 930 μg (potency) and not more than 1020 μg (potency) per mg, calculated on the anhydrous basis. The potency of Cefixime Hydrate is expressed as mass (potency) of cefixime ($\text{C}_{16}\text{H}_{15}\text{N}_5\text{O}_7\text{S}_2$: 453.45).

Description Cefixime Hydrate occurs as a white to light yellow crystalline powder.

It is freely soluble in methanol and in dimethylsulfoxide, sparingly soluble in ethanol (99.5), and practically insoluble in water.

Identification (1) Determine the absorption spectrum of a solution of Cefixime Hydrate in 0.1 mol/L phosphate buffer solution (pH 7.0) (1 in 62,500) as directed under Ultraviolet-visible Spectrophotometry <2.24>, and compare the spectrum with the Reference Spectrum or the spectrum of a solution of Cefixime RS prepared in the same manner as the sample solution: both spectra exhibit similar intensities of absorption at the same wavelengths.

(2) Determine the infrared absorption spectrum of Cefixime Hydrate as directed in the potassium bromide disk method under Infrared Spectrophotometry <2.25>, and compare the spectrum with the Reference Spectrum or the spectrum of Cefixime RS: both spectra exhibit similar intensities of absorption at the same wave numbers.

(3) Dissolve 50 mg of Cefixime Hydrate in 0.5 mL of a mixture of deuterated dimethylsulfoxide for nuclear magnetic resonance spectroscopy and heavy water for nuclear magnetic resonance spectroscopy (4:1). Determine the ^1H spectrum of this solution, as directed under Nuclear Magnetic Resonance Spectroscopy <2.21>, using tetramethylsilane for nuclear magnetic resonance spectroscopy as an internal reference compound: it exhibits a singlet signal A at around δ 4.7 ppm, and a multiplet signal B between δ 6.5 ppm and δ 7.4 ppm. The ratio of integrated intensity of these signals, A:B, is about 1:1.

Optical rotation <2.49> $[\alpha]_D^{20}$: $-75 - -88^\circ$ (0.45 g calculated on the anhydrous bases, a solution of sodium hydrogen carbonate (1 in 50), 50 mL, 100 mm).

Purity Dissolve 0.1 g of Cefixime Hydrate in 100 mL of 0.1 mol/L phosphate buffer solution (pH 7.0), and use this solution as the sample solution. Perform the test with 10 μL of the sample solution as directed under Liquid Chromatography <2.01> according to the following conditions. Determine each peak area by the automatic integration method, and calculate their amounts by the area percentage method: the amount of the peak other than cefixime is not more than 1.0%, and the total amount of the peaks other than cefixime is not more than 2.5%.

Operating conditions—

Detector, column, column temperature, mobile phase, and flow rate: Proceed as directed in the operating conditions in the Assay.

Time span of measurement: About 3 times as long as the retention time of cefixime, beginning after the solvent peak.

System suitability—

Test for required detectability: To 1 mL of the sample solution add 0.1 mol/L phosphate buffer solution (pH 7.0) to make 100 mL, and use this solution as the solution for system suitability test. Pipet 1 mL of the solution for system suitability test, add 0.1 mol/L phosphate buffer solution (pH 7.0) to make exactly 10 mL. Confirm that the peak area of cefixime obtained with 10 μL of this solution is equivalent to 7 to 13% of that with 10 μL of the solution for system suitability test.

System performance: When the procedure is run with 10 μL of the solution for system suitability test under the above operating conditions, the number of theoretical plates and the symmetry factor of the peak of cefixime are not less than 4000 and not more than 2.0, respectively.

System repeatability: When the test is repeated 6 times with 10 μL of the solution for system suitability test under the above operating conditions, the relative standard deviation of the peak areas of cefixime is not more than 2.0%.

Water <2.48> Not less than 9.0 and not more than 12.0% (0.1 g, volumetric titration, direct titration).

Residue on ignition <2.44> Not more than 0.1% (1 g).

Assay Weigh accurately an amount of Cefixime Hydrate, equivalent to about 0.1 g (potency), and dissolve in 0.1 mol/L phosphate buffer solution (pH 7.0) to make exactly 100 mL. Pipet 10 mL of this solution, add 0.1 mol/L phosphate buffer solution (pH 7.0) to make exactly 50 mL, and use this solution as the sample solution. Separately, weigh accurately an amount of Cefixime RS, equivalent to about 20 mg (potency), and dissolve in 0.1 mol/L phosphate buffer solution (pH 7.0) to make exactly 20 mL. Pipet 10 mL of this solution, add 0.1 mol/L phosphate buffer solution (pH 7.0) to make exactly 50 mL, and use this solution as the standard solution. Perform the test with exactly 10 μL each of the sample solution and standard solution as directed under Liquid Chromatography <2.01> according to the following conditions, and determine the peak areas, A_T and A_S , of cefixime in each solution.

$$\begin{aligned} \text{Amount } [\mu\text{g (potency)}] \text{ of cefixime (C}_{16}\text{H}_{15}\text{N}_5\text{O}_7\text{S}_2) \\ = M_S \times A_T/A_S \times 5000 \end{aligned}$$

M_S : Amount [mg (potency)] of Cefixime RS taken

Operating conditions—

Detector: An ultraviolet absorption photometer (wavelength: 254 nm).

Column: A stainless steel column 4 mm in inside diameter and 125 mm in length, packed with octadecylsilanized silica gel for liquid chromatography (4 μm in particle diameter).

Column temperature: A constant temperature of about 40°C.

Mobile phase: To 25 mL of a solution of tetrabutylammonium hydroxide TS (10 in 13) add water to make 1000 mL, and adjust to pH 6.5 with diluted phosphoric acid (1 in 10). To 300 mL of this solution add 100 mL of acetonitrile.

Flow rate: Adjust so that the retention time of cefixime is about 10 minutes.

System suitability—

System performance: When the procedure is run with 10 μL of the standard solution under the above operating conditions, the number of theoretical plates and the symmetry factor of the peak of cefixime are not less than 4000 and not more than 2.0, respectively.

System repeatability: When the test is repeated 6 times with 10 μL of the standard solution under the above operating conditions, the relative standard deviation of peak area of cefixime is not more than 2.0%.

Containers and storage Containers—Hermetic containers. Storage—Light-resistant.

Cefixime Capsules

セフィキシムカプセル

Cefixime Capsules contain not less than 90.0% and not more than 105.0% of the labeled potency of cefixime ($\text{C}_{16}\text{H}_{15}\text{N}_5\text{O}_7\text{S}_2$; 453.45).

Method of preparation Prepare as directed under Capsules, with Cefixime Hydrate.

Identification Take out the contents of Cefixime Capsules, to a quantity of the contents of Cefixime Capsules, equivalent to 70 mg (potency) of Cefixime Hydrate, add 100 mL of 0.1 mol/L phosphate buffer solution (pH 7.0), shake for 30 minutes, and filter. To 1 mL of the filtrate add 0.1 mol/L phosphate buffer solution (pH 7.0) to make 50 mL. Determine the absorption spectrum of this solution as directed under Ultraviolet-visible Spectrophotometry <2.24>: it exhibits a maximum between 286 nm and 290 nm.

Purity Related substances—Take out the contents of Cefixime Capsules, to a quantity of the contents of Cefixime Capsules, equivalent to 0.1 g (potency) of Cefixime Hydrate, add 100 mL of 0.1 mol/L phosphate buffer solution (pH 7.0), shake for 30 minutes, filter, and use the filtrate as the sample solution. Perform the test with 10 μL of the sample solution as directed under Liquid Chromatography <2.01> according to the following conditions. Determine each peak area from the sample solution by the automatic integration method, and calculate the amount of them by the area percentage method: the amount of each peak other than cefixime is not more than 1.0%, and the total amount of the peaks other than cefixime is not more than 2.5%.

Operating conditions—

Detector, column, column temperature, mobile phase and flow rate: Proceed as directed in the operating conditions in the Assay under Cefixime Hydrate.

Time span for measurement: Proceed as directed in the operating conditions in the Purity under Cefixime Hydrate.

System suitability—

Test for required detectability: Pipet 1 mL of the sample

solution, and add 0.1 mol/L phosphate buffer solution (pH 7.0) to make exactly 100 mL, and use this solution as the solution for system suitability test. Pipet 1 mL of the solution for system suitability test, and add 0.1 mol/L phosphate buffer solution (pH 7.0) to make exactly 10 mL. Confirm that the peak area of cefixime obtained with 10 μL of this solution is equivalent to 7 to 13% of that with 10 μL of the solution for system suitability test.

System performance: When the procedure is run with 10 μL of the solution for system suitability test under the above operating conditions, the number of theoretical plates and the symmetry factor of the peak of cefixime are not less than 4000 and not more than 2.0, respectively.

System repeatability: When the test is repeated 6 times with 10 μL of the solution for system suitability test under the above operating conditions, the relative standard deviation of the peak area of cefixime is not more than 2.0%.

Water <2.48> Not more than 12.0% (0.1 g of the contents, volumetric titration, direct titration).

Uniformity of dosage units <6.02> Perform the Mass variation test, or the Content uniformity test according to the following method: it meets the requirement.

Take out the contents of 1 capsule of Cefixime Capsules, and to the contents and the capsule shells add 7V/10 mL of 0.1 mol/L phosphate buffer solution (pH 7.0), shake for 30 minutes, and add 0.1 mol/L phosphate buffer solution (pH 7.0) to make exactly V mL so that each mL contains about 1 mg (potency) of Cefixime Hydrate. Centrifuge this solution, pipet 10 mL of the supernatant liquid, add 0.1 mol/L phosphate buffer solution (pH 7.0) to make exactly 50 mL, and use this solution as the sample solution. Separately, weigh accurately an amount of Cefixime RS, equivalent to about 20 mg (potency), dissolve in 0.1 mol/L phosphate buffer solution (pH 7.0) to make exactly 100 mL, and use this solution as the standard solution. Then, proceed as directed in the Assay under Cefixime Hydrate.

$$\begin{aligned} &\text{Amount [mg (potency)] of cefixime } (\text{C}_{16}\text{H}_{15}\text{N}_5\text{O}_7\text{S}_2) \\ &= M_S \times A_T/A_S \times V/20 \end{aligned}$$

M_S : Amount [mg (potency)] of Cefixime RS taken

Dissolution <6.10> When the test is performed at 50 revolutions per minute according to the Paddle method using the sinker, using 900 mL of disodium hydrogen phosphate-citric acid buffer solution (pH 7.5) as the dissolution medium, the dissolution rates in 60 minutes of 50-mg (potency) capsule and in 90 minutes of 100-mg (potency) capsule are not less than 80%, respectively.

Start the test with 1 capsule of Cefixime Capsules, withdraw not less than 20 mL of the medium at the specified minute after starting the test, and filter through a membrane filter with a pore size not exceeding 0.5 μm . Discard not less than 10 mL of the first filtrate, pipet V mL of the subsequent filtrate, add the dissolution medium to make exactly V' mL so that each mL contains about 56 μg (potency) of Cefixime Hydrate, and use this solution as the sample solution. Separately, weigh accurately an amount of Cefixime RS, equivalent to about 28 mg (potency), and dissolve in the dissolution medium to make exactly 100 mL. Pipet 4 mL of this solution, add the dissolution medium to make exactly 20 mL, and use this solution as the standard solution. Perform the test with exactly 20 μL each of the sample solution and standard solution as directed under Liquid Chromatography <2.01> according to the following conditions, and determine the peak areas, A_T and A_S , of cefixime in each solution.

Dissolution rate (%) with respect to the labeled amount of cefixime ($C_{16}H_{15}N_5O_7S_2$)

$$= M_S \times A_T/A_S \times V'/V \times 1/C \times 180$$

M_S : Amount [mg (potency)] of Cefixime RS taken

C : Labeled amount [mg (potency)] of Cefixime Hydrate in 1 capsule

Operating conditions—

Proceed as directed in the operating conditions in the Assay under Cefixime Hydrate.

System suitability—

System performance: When the procedure is run with 20 μ L of the standard solution under the above operating conditions, the number of theoretical plates and the symmetry factor of the peak of cefixime are not less than 4000 and not more than 2.0, respectively.

System repeatability: When the test is repeated 6 times with 20 μ L of the standard solution under the above operating conditions, the relative standard deviation of the peak area of cefixime is not more than 2.0%.

Assay Take out the contents of not less than 20 Cefixime Capsules, weigh accurately the mass of the contents, and powder. Weigh accurately a portion of the powder, equivalent to about 0.1 g (potency) of Cefixime Hydrate, add 70 mL of 0.1 mol/L phosphate buffer solution (pH 7.0) and shake for 30 minutes, add 0.1 mol/L phosphate buffer solution (pH 7.0) to make exactly 100 mL. Centrifuge this solution, pipet 10 mL of the supernatant liquid, add 0.1 mol/L phosphate buffer solution (pH 7.0) to make exactly 50 mL, and use this solution as the sample solution. Separately, weigh accurately an amount of Cefixime RS, equivalent to about 20 mg (potency), dissolve in 0.1 mol/L phosphate buffer solution (pH 7.0) to make exactly 100 mL, and use this solution as the standard solution. Then, proceed as directed in the Assay under Cefixime Hydrate.

$$\begin{aligned} &\text{Amount [mg (potency)] of cefixime (C}_{16}\text{H}_{15}\text{N}_5\text{O}_7\text{S}_2) \\ &= M_S \times A_T/A_S \times 5 \end{aligned}$$

M_S : Amount [mg (potency)] of Cefixime RS taken

Containers and storage Containers—Tight containers.

Cefixime Fine Granules

セフィキシム細粒

Cefixime Fine Granules contain not less than 90.0% and not more than 105.0% of the labeled potency of cefixime ($C_{16}H_{15}N_5O_7S_2$: 453.45).

Method of preparation Prepare as directed under Granules, with Cefixime Hydrate.

Identification To a quantity of powdered Cefixime Fine Granules, equivalent to 2 mg (potency) of Cefixime Hydrate, add 150 mL of 0.1 mol/L phosphate buffer solution (pH 7.0), and shake. If necessary, filter or centrifuge. Determine the absorption spectrum of this solution as directed under Ultraviolet-visible Spectrophotometry <2.24>: it exhibits maximum between 286 nm and 290 nm.

Purity Related substances—To a quantity of powdered Cefixime Fine Granules, equivalent to 0.1 g (potency) of Cefixime Hydrate, add 100 mL of 0.1 mol/L phosphate buffer solution (pH 7.0), shake, filter through a membrane filter with a pore size not exceeding 0.45 μ m, and use the filtrate as the sample solution. Perform the test with 10 μ L of

the sample solution as directed under Liquid Chromatography <2.01> according to the following conditions. Determine each peak area by the automatic integration method, and calculate their amounts by the area percentage method: the amount of the peak other than cefixime is not more than 1.0%, and the total amount of the peaks other than cefixime is not more than 2.5%.

Operating conditions—

Detector, column, column temperature, mobile phase and flow rate: Proceed as directed in the operating conditions in the Assay under Cefixime Hydrate.

Time span of measurement: Proceed as directed in the operating conditions in the Purity under Cefixime Hydrate.

System suitability—

Test for required detectability: To 1 mL of the sample solution add 0.1 mol/L phosphate buffer solution (pH 7.0) to make 100 mL, and use this solution as the solution for system suitability test. Pipet 1 mL of the solution for system suitability test, and add 0.1 mol/L phosphate buffer solution (pH 7.0) to make exactly 10 mL. Confirm that the peak area of cefixime obtained with 10 μ L of this solution is equivalent to 7 to 13% of that with 10 μ L of the solution for system suitability test.

System performance: When the procedure is run with 10 μ L of the solution for system suitability test under the above operating conditions, the number of theoretical plates and the symmetry factor of the peak of cefixime are not less than 4000 and not more than 2.0, respectively.

System repeatability: When the test is repeated 6 times with 10 μ L of the solution for system suitability test under the above operating conditions, the relative standard deviation of the peak area of cefixime is not more than 2.0%.

Water <2.48> Not more than 3.0% (1 g, volumetric titration, direct titration. Use a mixture of formamide for water determination and methanol for water determination (2:1) instead of methanol for water determination).

Uniformity of dosage units <6.02> Perform the test according to the following method: Cefixime Fine Granules in single-dose packages meet the requirement of the Content uniformity test.

To the total content of 1 package of Cefixime Fine Granules add 7 $V/10$ mL of 0.1 mol/L phosphate buffer solution (pH 7.0), shake, add 0.1 mol/L phosphate buffer solution (pH 7.0) to make exactly V mL so that each mL contains about 1 mg (potency) of Cefixime Hydrate. Centrifuge this solution, pipet 10 mL of the supernatant liquid, add 0.1 mol/L phosphate buffer solution (pH 7.0) to make exactly 50 mL, and use this solution as the sample solution. Separately, weigh accurately an amount of Cefixime RS, equivalent to about 20 mg (potency), dissolve in 0.1 mol/L phosphate buffer solution (pH 7.0) to make exactly 100 mL, and use this solution as the standard solution. Then, proceed as directed in the Assay under Cefixime Hydrate.

$$\begin{aligned} &\text{Amount [mg (potency)] of cefixime (C}_{16}\text{H}_{15}\text{N}_5\text{O}_7\text{S}_2) \\ &= M_S \times A_T/A_S \times V/20 \end{aligned}$$

M_S : Amount [mg (potency)] of Cefixime RS taken

Dissolution <6.10> When the test is performed at 50 revolutions per minute according to the Paddle method, using 900 mL of 2nd fluid for dissolution test as the dissolution medium, the dissolution rates in 30 minutes of Cefixime Fine Granules is not less than 75%.

Start the test with an accurately weighed amount of Cefixime Fine Granules, equivalent to about 0.1 g (potency) of Cefixime Hydrate, withdraw not less than 20 mL of the

medium at the specified minute after starting the test, and filter through a membrane filter with a pore size not exceeding $0.45\ \mu\text{m}$. Discard not less than 10 mL of the first filtrate, and use the subsequent filtrate as the sample solution. Separately, weigh accurately an amount of Cefixime RS, equivalent to about 28 mg (potency), and dissolve in the dissolution medium to make exactly 50 mL. Pipet 4 mL of this solution, add the dissolution medium to make exactly 20 mL, and use this solution as the standard solution. Perform the test with exactly $20\ \mu\text{L}$ each of the sample solution and standard solution as directed under Liquid Chromatography <2.01> according to the following conditions, and determine the peak areas, A_T and A_S , of cefixime in each solution.

Dissolution rate (%) with respect to the labeled amount of cefixime ($\text{C}_{16}\text{H}_{15}\text{N}_5\text{O}_7\text{S}_2$)

$$= M_S/M_T \times A_T/A_S \times 1/C \times 360$$

M_S : Amount [mg (potency)] of Cefixime RS taken

M_T : Amount (g) of Cefixime Fine Granules taken

C: Labeled amount [mg (potency)] of cefixime ($\text{C}_{16}\text{H}_{15}\text{N}_5\text{O}_7\text{S}_2$) in 1 g

Operating conditions—

Proceed as directed in the operating conditions in the Assay under Cefixime Hydrate.

System suitability—

System performance: When the procedure is run with $20\ \mu\text{L}$ of the standard solution under the above operating conditions, the number of theoretical plates and the symmetry factor of the peak of cefixime are not less than 4000 and not more than 2.0, respectively.

System repeatability: When the test is repeated 6 times with $20\ \mu\text{L}$ of the standard solution under the above operating conditions, the relative standard deviation of the peak area of cefixime is not more than 2.0%.

Assay Weigh accurately an amount of powdered Cefixime Fine Granules, equivalent to about 0.1 g (potency) of Cefixime Hydrate, add 70 mL of 0.1 mol/L phosphate buffer solution (pH 7.0), shake, and add 0.1 mol/L phosphate buffer solution (pH 7.0) to make exactly 100 mL. Centrifuge this solution, pipet 10 mL of the supernatant liquid, add 0.1 mol/L phosphate buffer solution (pH 7.0) to make exactly 50 mL, and use this solution as the sample solution. Separately, weigh accurately an amount of Cefixime RS, equivalent to about 20 mg (potency), dissolve in 0.1 mol/L phosphate buffer solution (pH 7.0) to make exactly 100 mL, and use this solution as the standard solution. Then, proceed as directed in the Assay under Cefixime Hydrate.

Amount [mg (potency)] of cefixime ($\text{C}_{16}\text{H}_{15}\text{N}_5\text{O}_7\text{S}_2$)

$$= M_S \times A_T/A_S \times 5$$

M_S : Amount [mg (potency)] of Cefixime RS taken

Containers and storage Containers—Tight containers.

Cefmenoxime Hydrochloride

セフメノキシム塩酸塩

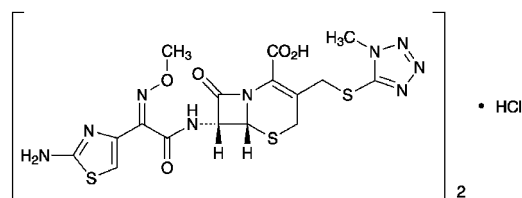

($\text{C}_{16}\text{H}_{17}\text{N}_9\text{O}_5\text{S}_3$) $\cdot\text{HCl}$: 1059.58

(6*R*,7*R*)-7-[(*Z*)-2-(2-Aminothiazol-4-yl)-2-(methoxyimino)acetylamino]-3-(1-methyl-1*H*-tetrazol-5-ylsulfanylmethyl)-8-oxo-5-thia-1-azabicyclo[4.2.0]oct-2-ene-2-carboxylic acid hemihydrochloride
[75738-58-8]

Cefmenoxime Hydrochloride contains not less than 890 μg (potency) and not more than 975 μg (potency) per mg, calculated on the anhydrous basis. The potency of Cefmenoxime Hydrochloride is expressed as mass (potency) of cefmenoxime ($\text{C}_{16}\text{H}_{17}\text{N}_9\text{O}_5\text{S}_3$: 511.56).

Description Cefmenoxime Hydrochloride occurs as white to light orange-yellow, crystals or crystalline powder.

It is freely soluble in formamide and in dimethylsulfoxide, slightly soluble in methanol, very slightly soluble in water, and practically insoluble in ethanol (95).

Identification (1) Determine the absorption spectrum of a solution of Cefmenoxime Hydrochloride in 0.1 mol/L phosphate buffer solution (pH 6.8) (3 in 200,000) as directed under Ultraviolet-visible Spectrophotometry <2.24>, and compare the spectrum with the Reference Spectrum or the spectrum of a solution of Cefmenoxime Hydrochloride RS prepared in the same manner as the sample solution: both spectra exhibit similar intensities of absorption at the same wavelengths.

(2) Determine the infrared absorption spectrum of Cefmenoxime Hydrochloride as directed in the potassium bromide disk method under Infrared Spectrophotometry <2.25>, and compare the spectrum with the Reference Spectrum or the spectrum of Cefmenoxime Hydrochloride RS: both spectra exhibit similar intensities of absorption at the same wave numbers.

(3) Determine the ^1H spectrum of a solution of Cefmenoxime Hydrochloride in deuterated dimethylsulfoxide for nuclear magnetic resonance spectroscopy (1 in 10) as directed under Nuclear Magnetic Resonance Spectroscopy <2.21>, using tetramethylsilane for nuclear magnetic resonance spectroscopy as an internal reference compound: it exhibits two singlet signals, A and B, at around δ 3.9 ppm, and a singlet signal C at around δ 6.8 ppm. The ratio of the integrated intensity of each signal, A:B:C, is about 3:3:1.

(4) Dissolve 10 mg of Cefmenoxime Hydrochloride in 1 mL of diluted sodium carbonate TS (1 in 20), add 5 mL of acetic acid (100) and 2 drops of silver nitrate TS: a white precipitate is formed.

Optical rotation <2.49> $[\alpha]_D^{20}$: $-27 - -35^\circ$ (1 g, 0.1 mol/L phosphate buffer solution (pH 6.8), 100 mL, 100 mm).

pH <2.54> The pH of a solution obtained by dissolving 0.10 g of Cefmenoxime Hydrochloride in 150 mL of water is between 2.8 and 3.3.

Purity (1) Clarity and color of solution—A solution obtained by dissolving 1.0 g of Cefmenoxime Hydrochloride in 10 mL of diluted sodium carbonate TS (1 in 4) is clear and colorless to light yellow.

(2) Heavy metals <1.07>—Proceed with 1.0 g of Cefmenoxime Hydrochloride according to Method 4, and perform the test. Prepare the control solution with 2.0 mL of Standard Lead Solution (not more than 20 ppm).

(3) Arsenic <1.11>—Prepare the test solution with 1.0 g of Cefmenoxime Hydrochloride according to Method 4 and adding 10 mL of dilute hydrochloric acid to the residue after cooling, and perform the test (not more than 2 ppm).

(4) Related substances—Weigh accurately about 0.1 g of Cefmenoxime Hydrochloride, dissolve in 20 mL of 0.1 mol/L phosphate buffer solution (pH 6.8) and add the mobile phase to make exactly 100 mL. Pipet 4 mL of this solution, add the mobile phase to make exactly 50 mL, and use this solution as the sample solution. Separately, weigh accurately about 10 mg of 1-methyl-1*H*-tetrazol-5-thiol, and dissolve in the mobile phase to make exactly 100 mL. Pipet 4 mL of this solution, add the mobile phase to make exactly 250 mL, and use this solution as the standard solution (1). Weigh accurately about 0.1 g of Cefmenoxime Hydrochloride RS, dissolve in 20 mL of 0.1 mol/L phosphate buffer solution (pH 6.8) and add the mobile phase to make exactly 100 mL. Pipet 1 mL of this solution, add the mobile phase to make exactly 250 mL, and use this solution as the standard solution (2). Perform the test immediately after preparation of these solutions with exactly 10 μ L each of the sample solution and standard solutions (1) and (2) as directed under Liquid Chromatography <2.01> according to the following conditions. Determine each peak area of these solutions by the automatic integration method, and calculate the amounts of 1-methyl-1*H*-tetrazol-5-thiol and the total related substance by the following formula: the amount of 1-methyl-1*H*-tetrazol-5-thiol is not more than 1.0%, and the total related substance is not more than 3.0%.

$$\begin{aligned} \text{Amount (\%)} \text{ of 1-methyl-1H-tetrazol-5-thiol} \\ = M_{Sa}/M_T \times A_{Ta}/A_{Sa} \times 20 \end{aligned}$$

$$\begin{aligned} \text{Amount (\%)} \text{ of total related substances} \\ = M_{Sa}/M_T \times A_{Ta}/A_{Sa} \times 20 \\ + M_{Sb}/M_T \times S_T/A_{Sb} \times 5 \end{aligned}$$

M_{Sa} : Amount (g) of 1-methyl-1*H*-tetrazol-5-thiol taken

M_{Sb} : Amount (g) of Cefmenoxime Hydrochloride RS taken

M_T : Amount (g) of Cefmenoxime Hydrochloride taken

A_{Sa} : Peak area of 1-methyl-1*H*-tetrazol-5-thiol from the standard solution (1)

A_{Sb} : Peak area of cefmenoxime from the standard solution (2)

A_{Ta} : Peak area of 1-methyl-1*H*-tetrazol-5-thiol from the sample solution

S_T : Total area of the peaks other than 1-methyl-1*H*-tetrazol-5-thiol and other than cefmenoxime from the sample solution

Operating conditions—

Detector, column, column temperature, mobile phase, and flow rate: Proceed as directed in the operating conditions in the Assay.

Time span of measurement: About 2.5 times as long as the retention time of cefmenoxime.

System suitability—

System performance: Proceed as directed in the system suitability in the Assay.

Test for required detectability: Measure exactly 5 mL of

the standard solution (1), add the mobile phase to make exactly 100 mL. Confirm that the peak area of 1-methyl-1*H*-tetrazol-5-thiol obtained with 10 μ L of this solution is equivalent to 4.5 to 5.5% of that with 10 μ L of the standard solution (1). Then, measure exactly 2 mL of the standard solution (2), add the mobile phase to make exactly 100 mL. Confirm that the peak area of cefmenoxime obtained with 10 μ L of this solution is equivalent to 1.5 to 2.5% of that with 10 μ L of the standard solution (2).

System repeatability: When the test is repeated 6 times with 10 μ L of the standard solution (1) under the above operating conditions, the relative standard deviation of the peak area of 1-methyl-1*H*-tetrazol-5-thiol is not more than 1.0%.

Water <2.48> Not more than 1.5% (1 g, volumetric titration, direct titration. Use a mixture of formamide for water determination and methanol for water determination (2:1)).

Assay Weigh accurately an amount of Cefmenoxime Hydrochloride and Cefmenoxime Hydrochloride RS, equivalent to about 50 mg (potency), dissolve each in 10 mL of 0.1 mol/L phosphate buffer solution (pH 6.8) and add the mobile phase to make exactly 50 mL. Pipet 4 mL each of these solutions, add exactly 20 mL of the internal standard solution and the mobile phase to make 50 mL, and use these solutions as the sample solution and the standard solution, respectively. Perform the test with 10 μ L each of the sample solution and standard solution as directed under Liquid Chromatography <2.01> according to the following conditions, and calculate the ratios, Q_T and Q_S , of the peak area of cefmenoxime to that of the internal standard.

$$\begin{aligned} \text{Amount } [\mu\text{g (potency)}] \text{ of cefmenoxime (C}_{16}\text{H}_{17}\text{N}_9\text{O}_5\text{S}_3) \\ = M_S \times Q_T/Q_S \times 1000 \end{aligned}$$

M_S : Amount [mg (potency)] of Cefmenoxime Hydrochloride RS taken

Internal standard solution—A solution of phthalimide in methanol (3 in 2000).

Operating conditions—

Detector: An ultraviolet absorption photometer (wavelength: 254 nm).

Column: A stainless steel column 4 mm in inside diameter and 15 cm in length, packed with octadecylsilanized silica gel for liquid chromatography (5 μ m in particle diameter).

Column temperature: A constant temperature of about 25°C.

Mobile phase: A mixture of water, acetonitrile and acetic acid (100) (50:10:1).

Flow rate: Adjust so that the retention time of cefmenoxime is about 8 minutes.

System suitability—

System performance: When the procedure is run with 10 μ L of the standard solution under the above operating conditions, cefmenoxime and the internal standard are eluted in this order with the resolution between these peaks being not less than 2.3.

System repeatability: When the test is repeated 6 times with 10 μ L of the standard solution under the above operating conditions, the relative standard deviation of the ratios of the peak areas of cefmenoxime to that of the internal standard is not more than 1.0%.

Containers and storage Containers—Hermetic containers.

Cefmetazole Sodium

セフメタゾールナトリウム

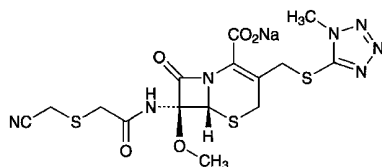

$C_{15}H_{16}N_7NaO_5S_3$: 493.52

Monosodium (6*R*,7*R*)-7-

{[(cyanomethylsulfanyl)acetyl]amino}-7-methoxy-3-(1-methyl-1*H*-tetrazol-5-ylsulfanylmethyl)-8-oxo-5-thia-1-azabicyclo[4.2.0]oct-2-ene-2-carboxylate
[56796-20-4]

Cefmetazole Sodium contains not less than 860 μg (potency) and not more than 965 μg (potency) per mg, calculated on the anhydrous basis. The potency of Cefmetazole Sodium is expressed as mass (potency) of cefmetazole ($C_{15}H_{17}N_7O_5S_3$: 471.53).

Description Cefmetazole Sodium occurs as a white to light yellow-white, powder or mass.

It is very soluble in water, freely soluble in methanol, slightly soluble in ethanol (95), and very slightly soluble in tetrahydrofuran.

It is hygroscopic.

Identification (1) Determine the absorption spectrum of a solution of Cefmetazole Sodium (1 in 40,000) as directed under Ultraviolet-visible Spectrophotometry <2.24>, and compare the spectrum with the Reference Spectrum: both spectra exhibit similar intensities of absorption at the same wavelengths.

(2) Determine the infrared absorption spectrum of Cefmetazole Sodium as directed in the potassium bromide disk method under Infrared Spectrophotometry <2.25>, and compare the spectrum with the Reference Spectrum: both spectra exhibit similar intensities of absorption at the same wave numbers.

(3) Determine the ^1H spectrum of a solution of Cefmetazole Sodium in heavy water for nuclear magnetic resonance spectroscopy (1 in 10) as directed under Nuclear Magnetic Resonance Spectroscopy <2.21>, using sodium 3-trimethylsilylpropanesulfonate for nuclear magnetic resonance spectroscopy as an internal reference compound: it exhibits singlet signals, A, B and C, at around δ 3.6 ppm, at around δ 4.1 ppm and at around δ 5.2 ppm, respectively. The ratio of integrated intensity of each signal, A:B:C, is about 3:3:1.

(4) Cefmetazole Sodium responds to Qualitative Tests <1.09> (1) for sodium salt.

Optical rotation <2.49> $[\alpha]_D^{20}$: +73 – +85° (0.25 g, water, 25 mL, 100 mm).

pH <2.54> Dissolve 1.0 g of Cefmetazole Sodium in 10 mL of water: the pH of the solution is between 4.2 and 6.2.

Purity (1) Clarity and color of solution—Dissolve 1.0 g of Cefmetazole Sodium in 10 mL of water: the solution is clear, and has no more color than the following control solution.

Control solution: To a mixture of exactly 0.5 mL of Cobalt (II) Chloride CS and exactly 5 mL of Iron (III) Chloride CS add water to make exactly 50 mL. To exactly 15 mL of this solution add water to make exactly 20 mL.

(2) Heavy metals <1.07>—Proceed with 1.0 g of Cefmetazole Sodium according to Method 2, and perform the test. Prepare the control solution with 2.0 mL of Standard Lead Solution (not more than 20 ppm).

(3) Arsenic <1.11>—Prepare the test solution with 1.0 g of Cefmetazole Sodium according to Method 3, and perform the test (not more than 2 ppm).

(4) Related substances—Dissolve 0.50 g of Cefmetazole Sodium in 10 mL of water, and use this solution as the sample solution. Pipet 4 mL, 2 mL, 1 mL, 0.5 mL and 0.25 mL of the sample solution, add water to them to make exactly 100 mL, and use these solutions as the standard solutions (1), (2), (3), (4) and (5), respectively. Separately, dissolve 0.10 g of 1-methyl-1*H*-tetrazole-5-thiol in water to make exactly 100 mL, and use this solution as the standard solution (6). Perform the test with these solutions as directed under Thin-layer Chromatography <2.03>. Spot 1 μL each of the sample solution and standard solutions (1) to (6) on a plate of silica gel for thin-layer chromatography. Develop with a mixture of 1-butanol, water and acetic acid (100) (4:1:1) to a distance of about 12 cm, and air-dry the plate. Allow the plate to stand in iodine vapor: the spot obtained from the sample solution corresponding to the spot from the standard solution (6) is not more intense than the spot from the standard solution (6), and the spots other than this spot and other than the principal spot are not more intense than the spot from the standard solution (1). Furthermore, the total amount of the spots other than the principal spot from the sample solution, calculated by the comparison with the spots from the standard solutions (1), (2), (3), (4) and (5), is not more than 8.0%.

Water <2.48> Not more than 1.0% (1 g, volumetric titration, direct titration).

Assay Weigh accurately an amount of Cefmetazole Sodium and Cefmetazole RS, equivalent to about 50 mg (potency), and dissolve each in the mobile phase to make exactly 25 mL. Pipet 1 mL each of these solutions, add exactly 10 mL of the internal standard solution, and use these solutions as the sample solution and the standard solution, respectively. Perform the test with 10 μL each of the sample solution and standard solution as directed under Liquid Chromatography <2.01> according to the following conditions, and calculate the ratios, Q_T and Q_S , of the peak area of cefmetazole to that of the internal standard.

$$\text{Amount } [\mu\text{g (potency)}] \text{ of cefmetazole } (C_{15}H_{17}N_7O_5S_3) \\ = M_S \times Q_T / Q_S \times 1000$$

$$M_S: \text{Amount [mg (potency)] of Cefmetazole RS taken}$$

Internal standard solution—A solution of methyl parahydroxybenzoate in the mobile phase (1 in 10,000).

Operating conditions—

Detector: An ultraviolet absorption photometer (wavelength: 214 nm).

Column: A stainless steel column 4.6 mm in inside diameter and 25 cm in length, packed with octadecylsilanized silica gel for liquid chromatography (5 μm in particle diameter).

Column temperature: A constant temperature of about 25°C.

Mobile phase: Dissolve 5.75 g of ammonium dihydrogenphosphate in 700 mL of water, add 280 mL of methanol, 20 mL of tetrahydrofuran and 3.2 mL of 40% tetrabutylammonium hydroxide TS, and adjust to pH 4.5 with phosphoric acid.

Flow rate: Adjust so that the retention time of cefmetazole is about 8 minutes.

System suitability—

System performance: When the procedure is run with 10 μL of the standard solution under the above operating conditions, cefmetazole and the internal standard are eluted in this order with the resolution between these peaks being not less than 10.

System repeatability: When the test is repeated 5 times with 10 μL of the standard solution under the above operating conditions, the relative standard deviation of the ratios of the peak area of cefmetazole to that of the internal standard is not more than 1.0%.

Containers and storage Containers—Hermetic containers.

Cefmetazole Sodium for Injection

注射用セフメタゾールナトリウム

Cefmetazole Sodium for Injection is a preparation for injection which is dissolved before use.

It contains not less than 90.0% and not more than 110.0% of the labeled potency of cefmetazole ($\text{C}_{15}\text{H}_{17}\text{N}_7\text{O}_5\text{S}_3$; 471.53).

Method of preparation Prepare as directed under Injections, with Cefmetazole Sodium.

Description Cefmetazole Sodium for Injection is a white to light yellow powder or masses.

It is hygroscopic.

Identification (1) Determine the absorption spectrum of a solution of Cefmetazole Sodium for Injection (1 in 40,000) as directed under Ultraviolet-visible Spectrophotometry <2.24>, and compare the spectrum with the Reference Spectrum: both spectra exhibit similar intensities of absorption at the same wavelengths.

(2) Determine the infrared absorption spectrum of Cefmetazole Sodium for Injection as directed in the potassium bromide disk method under Infrared Spectrophotometry <2.25>, and compare the spectrum with the Reference Spectrum: both spectra exhibit similar intensities of absorption at the same wave numbers.

pH <2.54> Take an amount of Cefmetazole Sodium for Injection equivalent to 1.0 g (potency) of Cefmetazole Sodium, and dissolve in 10 mL of water: the pH of the solution is 4.2 to 6.2.

Purity (1) Clarity and color of solution—Dissolve an amount of Cefmetazole Sodium for Injection, equivalent to 1.0 g (potency) of Cefmetazole Sodium, in 10 mL of water: the solution is clear and the color is not darker than the following control solution.

Control solution: Pipet 5 mL of Iron (III) Chloride CS and 0.5 mL of Cobalt (II) Chloride CS, and add water to make exactly 50 mL. Pipet 15 mL of this solution, and add water to make exactly 20 mL.

(2) Related substances—Proceed as directed in the Purity (4) under Cefmetazole Sodium.

Bacterial endotoxins <4.01> Less than 0.06 EU/mg (potency).

Uniformity of dosage units <6.02> It meets the requirement of the Mass variation test.

Foreign particulate matter <6.06> Perform the test according to Method 2: it meets the requirement.

Insoluble particulate matter <6.07> It meets the requirement.

Sterility <4.06> Perform the test according to the Membrane filtration method: it meets the requirement.

Assay Take 10 containers of Cefmetazole Sodium for Injection, dissolve the contents of each in the mobile phase, rinse each of the containers with the mobile phase, combine the rinse with the respective previous solution, and add the mobile phase to make exactly 500 mL. Take exactly a volume of this solution equivalent to about 0.2 g (potency) of Cefmetazole Sodium, and add the mobile phase to make exactly 100 mL. Pipet 1 mL of this solution, add exactly 10 mL of the internal standard solution, and use this solution as the sample solution. Separately, weigh accurately an amount of Cefmetazole RS, equivalent to about 50 mg (potency), and dissolve in the mobile phase to make exactly 25 mL. Pipet 1 mL of this solution, add exactly 10 mL of the internal standard solution, and use this solution as the standard solution. Then, proceed as directed in the Assay under Cefmetazole Sodium.

$$\begin{aligned} &\text{Amount [mg (potency)] of cefmetazole (C}_{15}\text{H}_{17}\text{N}_7\text{O}_5\text{S}_3) \\ &= M_S \times Q_T / Q_S \times 4 \end{aligned}$$

M_S : Amount [mg (potency)] of Cefmetazole RS taken

Internal standard solution—A solution of methyl parahydroxybenzoate in the mobile phase (1 in 10,000).

Containers and storage Containers—Hermetic containers. Plastic containers for aqueous injections may be used.

Cefminox Sodium Hydrate

セフミノクスナトリウム水和物

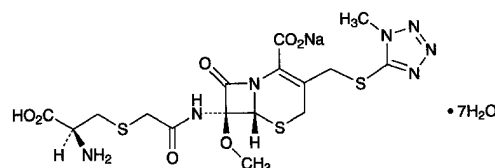

$\text{C}_{16}\text{H}_{20}\text{N}_7\text{NaO}_7\text{S}_3 \cdot 7\text{H}_2\text{O}$: 667.66
 Monosodium (6R,7S)-7-[(2S)-2-amino-2-carboxyethylsulfanyl]acetylamino-7-methoxy-3-(1-methyl-1H-tetrazol-5-ylsulfanylmethyl)-8-oxo-5-thia-1-azabicyclo[4.2.0]oct-2-ene-2-carboxylate heptahydrate [75498-96-3]

Cefminox Sodium Hydrate contains not less than 900 μg (potency) and not more than 970 μg (potency) per mg, calculated on the anhydrous basis. The potency of Cefminox Sodium Hydrate is expressed as mass (potency) of cefminox ($\text{C}_{16}\text{H}_{21}\text{N}_7\text{O}_7\text{S}_3$; 519.58).

Description Cefminox Sodium Hydrate occurs as a white to light yellow-white crystalline powder.

It is freely soluble in water, sparingly soluble in methanol, and practically insoluble in ethanol (99.5).

Identification (1) Determine the absorption spectrum of a solution of Cefminox Sodium Hydrate (1 in 50,000) as directed under Ultraviolet-visible Spectrophotometry <2.24>, and compare the spectrum with the Reference Spectrum or the spectrum of a solution of Cefminox Sodium RS prepared in the same manner as the sample solution: both spectra exhibit similar intensities of absorption at the same wave-

lengths.

(2) Determine the infrared absorption spectrum of Cefminox Sodium Hydrate as directed in the potassium bromide disk method under Infrared Spectrophotometry <2.25>, and compare the spectrum with the Reference Spectrum or the spectrum of Cefminox Sodium RS: both spectra exhibit similar intensities of absorption at the same wave numbers.

(3) Determine the ^1H spectrum of a solution of Cefminox Sodium Hydrate in heavy water for nuclear magnetic resonance spectroscopy (1 in 30) as directed under Nuclear Magnetic Resonance Spectroscopy <2.21>, using sodium 3-trimethylsilylpropanesulfonate for nuclear magnetic resonance spectroscopy as an internal reference compound: it exhibits a multiplet signal, A, at around δ 3.2 ppm, a singlet signal, B, at around δ 3.5 ppm, a singlet signal, C, at around δ 4.0 ppm, and a singlet signal, D, at around δ 5.1 ppm. The ratio of integrated intensity of each signal, A:B:C:D, is about 2:3:3:1.

(4) Cefminox Sodium Hydrate responds to Qualitative Tests <1.09> (1) for sodium salt.

Optical rotation <2.49> $[\alpha]_D^{20}$: +62 – +72° (50 mg, water, 10 mL, 100 mm).

pH <2.54> Dissolve 0.70 g of Cefminox Sodium Hydrate in 10 mL of water: the pH of the solution is between 4.5 and 6.0.

Purity (1) Heavy metals <1.07>—Proceed with 2.0 g of Cefminox Sodium Hydrate according to Method 2, and perform the test. Prepare the control solution with 2.0 mL of Standard Lead Solution (not more than 10 ppm).

(2) Arsenic <1.11>—Prepare the test solution with 2.0 g of Cefminox Sodium Hydrate according to Method 3, and perform the test (not more than 1 ppm).

Water <2.48> Not less than 18.0% and not more than 20.0% (0.1 g, volumetric titration, direct titration).

Assay Perform the test according to the Cylinder-plate method as directed under Microbial Assay for Antibiotics <4.02> according to the following conditions.

(i) Test organism—*Escherichia coli* NIHJ

(ii) Culture medium—Use the medium iii in 3) under (1) Agar media for seed and base layer. Adjust the pH of the medium so that it will be 6.5 to 6.6 after sterilization.

(iii) Standard solution—Weigh accurately an amount of Cefminox Sodium RS, equivalent to about 40 mg (potency), dissolve in 0.05 mol/L phosphate buffer solution (pH 7.0) to make exactly 50 mL, and use this solution as the standard stock solution. Keep the standard stock solution at 5°C or below and use within 7 days. Take exactly a suitable amount of the standard stock solution before use, add 0.05 mol/L phosphate buffer solution (pH 7.0) to make solutions so that each mL contains 40 μg (potency) and 20 μg (potency), and use these solutions as the high concentration standard solution and the low concentration standard solution, respectively.

(iv) Sample solution—Weigh accurately an amount of Cefminox Sodium Hydrate equivalent to about 40 mg (potency), dissolve in 0.05 mol/L phosphate buffer solution (pH 7.0) to make exactly 50 mL. Take exactly a suitable amount of this solution, add 0.05 mol/L phosphate buffer solution (pH 7.0) to make solutions so that each mL contains 40 μg (potency) and 20 μg (potency), and use these solutions as the high concentration sample solution and the low concentration sample solution, respectively.

(v) Procedure—Incubate between 32°C and 35°C.

Containers and storage Containers—Hermetic containers.

Cefodizime Sodium

セフォジジムナトリウム

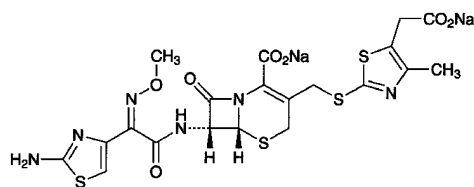

$\text{C}_{20}\text{H}_{18}\text{N}_6\text{Na}_2\text{O}_7\text{S}_4$: 628.63

Disodium (6*R*,7*R*)-7-[(*Z*)-2-(2-aminothiazol-4-yl)-2-(methoxyimino)acetyl-amino]-3-[(5-carboxylatomethyl)-4-methylthiazol-2-yl]sulfanylmethyl]-8-oxo-5-thia-1-azabicyclo[4.2.0]oct-2-ene-2-carboxylate
[86329-79-5]

Cefodizime Sodium contains not less than 890 μg (potency) per mg, calculated on the anhydrous and ethanol-free basis. The potency of Cefodizime Sodium is expressed as mass (potency) of cefodizime ($\text{C}_{20}\text{H}_{20}\text{N}_6\text{O}_7\text{S}_4$: 584.67).

Description Cefodizime Sodium occurs as a white to light yellow-white crystalline powder.

It is very soluble in water, and practically insoluble in acetonitrile and in ethanol (99.5).

Identification (1) Determine the absorption spectrum of a solution of Cefodizime Sodium (1 in 50,000) as directed under Ultraviolet-visible Spectrophotometry <2.24>, and compare the spectrum with the Reference Spectrum or the spectrum of a solution of Cefodizime Sodium RS prepared in the same manner as the sample solution: both spectra exhibit similar intensities of absorption at the same wavelengths.

(2) Determine the infrared absorption spectrum of Cefodizime Sodium as directed in the potassium bromide disk method under Infrared Spectrophotometry <2.25>, and compare the spectrum with the Reference Spectrum or the spectrum of Cefodizime Sodium RS: both spectra exhibit similar intensities of absorption at the same wave numbers.

(3) Determine the ^1H spectrum of a solution of Cefodizime Sodium in heavy water for nuclear magnetic resonance spectroscopy (1 in 10) as directed under Nuclear Magnetic Resonance Spectroscopy <2.21>, using sodium 3-trimethylsilylpropanesulfonate for nuclear magnetic resonance spectroscopy as an internal reference compound: it exhibits singlet signals, A, B and C, at around δ 2.3 ppm, at around δ 4.0 ppm, and at around δ 7.0 ppm. The ratio of the integrated intensity of these signals, A:B:C, is about 3:3:1.

(4) Cefodizime Sodium responds to Qualitative Tests <1.09> (1) for sodium salt.

Optical rotation <2.49> $[\alpha]_D^{20}$: –56 – –62° (0.2 g calculated on the anhydrous and ethanol-free basis, water, 20 mL, 100 mm).

pH <2.54> Dissolve 1.0 g of Cefodizime Sodium in 10 mL of water: the pH of the solution is between 5.5 and 7.5.

Purity (1) Clarity and color of solution—Dissolve 1.0 g of Cefodizime Sodium in 10 mL of water: the solution is clear and pale yellow to light yellow.

(2) Heavy metals <1.07>—Weigh 1.0 g of Cefodizime Sodium in a crucible, cover loosely, and carbonize by gentle heating. After cooling, add 2 mL of sulfuric acid, heat

gradually until the white fumes are no longer evolved, and ignite between 500°C and 600°C. Proceed according to Method 2, and perform the test. Prepare the control solution with 2.0 mL of Standard Lead Solution (not more than 20 ppm).

(3) Arsenic <1.11>—Prepare the test solution with 1.0 g of Cefodizime Sodium according to Method 3, and perform the test (not more than 2 ppm).

(4) Related substances—Dissolve 30 mg of Cefodizime Sodium in 10 mL of the mobile phase, and use this solution as the sample solution. Pipet 1 mL of the sample solution, add the mobile phase to make exactly 100 mL, and use this solution as the standard solution. Perform the test with exactly 5 μ L each of the sample solution and standard solution as directed under Liquid Chromatography <2.01> according to the following conditions, and determine each peak area by the automatic integration method: the area of the peaks other than cefodizime obtained from the sample solution is not larger than the peak area of cefodizime from the standard solution, and the total area of the peaks other than cefodizime from the sample solution is not larger than 3 times the peak area of cefodizime from the standard solution.

Operating conditions—

Detector, column, column temperature, mobile phase, and flow rate: Proceed as directed in the operating conditions in the Assay.

Time span of measurement: About 4 times as long as the retention time of cefodizime, beginning after the solvent peak.

System suitability—

System performance, and system repeatability: Proceed as directed in the system suitability in the Assay.

Test for required detectability: Measure exactly 2 mL of the standard solution, and add the mobile phase to make exactly 20 mL. Confirm that the peak area of cefodizime obtained with 5 μ L of this solution is equivalent to 7 to 13% of that with 5 μ L of the standard solution.

(5) Ethanol—Weigh accurately about 1 g of Cefodizime Sodium, and dissolve in water to make exactly 10 mL. Pipet 2 mL of this solution, add exactly 2 mL of the internal standard solution, and use this solution as the sample solution. Separately, weigh accurately about 2 g of ethanol for gas chromatography, and add water to make exactly 1000 mL. Pipet 2 mL of this solution, add exactly 2 mL of the internal standard solution, and use this solution as the standard solution. Perform the test with 10 μ L each of the sample solution and standard solution as directed under Gas Chromatography <2.02> according to the following conditions, and calculate the ratios, Q_T and Q_S , of the peak area of ethanol to that of the internal standard: the amount of ethanol is not more than 2.0%.

$$\text{Amount (\%)} \text{ of ethanol} = M_S/M_T \times Q_T/Q_S$$

M_S : Amount (g) of ethanol for gas chromatography taken

M_T : Amount (g) of Cefodizime Sodium taken

Internal standard solution—A solution of 1-propanol (1 in 400).

Operating conditions—

Detector: A hydrogen flame-ionization detector.

Column: A glass column 3.2 mm in inside diameter and 3 m in length, packed with tetrafluoroethylene polymer for gas chromatography (180–250 μ m in particle diameter) coated in 15% with polyethylene glycol 20 M.

Column temperature: A constant temperature of about 100°C.

Carrier gas: Nitrogen.

Flow rate: Adjust so that the retention time of ethanol is about 3 minutes.

System suitability—

System performance: When the procedure is run with 10 μ L of the standard solution under the above operating conditions, ethanol and the internal standard are eluted in this order with the resolution between these peaks being not less than 2.5.

System repeatability: When the test is repeated 6 times with 10 μ L of the standard solution under the above operating conditions, the relative standard deviation of the ratios of the peak area of ethanol to that of the internal standard is not more than 2.0%.

Water <2.48> Not more than 4.0% (0.5 g, volumetric titration, direct titration).

Assay Weigh accurately an amount of Cefodizime Sodium and Cefodizime Sodium RS, equivalent to about 50 mg (potency), add exactly 10 mL of the internal standard solution to dissolve, add water to make 100 mL, and use these solutions as the sample solution and standard solution. Perform the test with 10 μ L each of the sample solution and standard solution as directed under Liquid Chromatography <2.01> according to the following conditions, and calculate the ratios, Q_T and Q_S , of the peak area of cefodizime to that of the internal standard.

$$\begin{aligned} \text{Amount } [\mu\text{g (potency)}] \text{ of cefodizime (C}_{20}\text{H}_{20}\text{N}_6\text{O}_7\text{S}_4) \\ = M_S \times Q_T/Q_S \times 1000 \end{aligned}$$

M_S : Amount [mg (potency)] of Cefodizime Sodium RS taken

Internal standard solution—A solution of anhydrous caffeine (3 in 400).

Operating conditions—

Detector: An ultraviolet absorption photometer (wavelength: 254 nm).

Column: A stainless steel column 4.6 mm in inside diameter and 25 cm in length, packed with octadecylsilanized silica gel for liquid chromatography (10 μ m in particle diameter).

Column temperature: A constant temperature of about 25°C.

Mobile phase: Dissolve 0.80 g of potassium dihydrogen phosphate and 0.20 g of anhydrous disodium hydrogen phosphate in a suitable amount of water, and add 80 mL of acetonitrile and water to make 1000 mL.

Flow rate: Adjust so that the retention time of cefodizime is about 5 minutes.

System suitability—

System performance: When the procedure is run with 10 μ L of the standard solution under the above operating conditions, cefodizime and the internal standard are eluted in this order with the resolution between these peaks being not less than 6.

System repeatability: When the test is repeated 6 times with 10 μ L of the standard solution under the above operating conditions, the relative standard deviation of the ratios of the peak area of cefodizime to that of the internal standard is not more than 2.0%.

Containers and storage Containers—Tight containers.

Cefoperazone Sodium

セフォペラゾンナトリウム

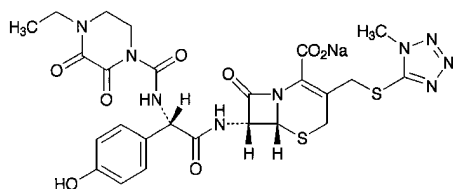

$C_{25}H_{26}N_9NaO_8S_2$: 667.65

Monosodium (6*R*,7*R*)-7-[(2*R*)-2-[(4-ethyl-2,3-dioxopiperazine-1-carbonyl)amino]-2-(4-hydroxyphenyl)acetyl-amino]-3-(1-methyl-1*H*-tetrazol-5-ylsulfanylmethyl)-8-oxo-5-thia-1-azabicyclo[4.2.0]oct-2-ene-2-carboxylate
[62893-20-3]

Cefoperazone Sodium contains not less than 871 μ g (potency) and not more than 986 μ g (potency) per mg, calculated on the anhydrous basis. The potency of Cefoperazone Sodium is expressed as mass (potency) of cefoperazone ($C_{25}H_{27}N_9O_8S_2$: 645.67).

Description Cefoperazone Sodium occurs as a white to yellowish white crystalline powder.

It is very soluble in water, soluble in methanol, and slightly soluble in ethanol (99.5).

Identification (1) Determine the absorption spectrum of a solution of Cefoperazone Sodium (1 in 50,000) as directed under Ultraviolet-visible Spectrophotometry <2.24>, and compare the spectrum with the Reference Spectrum: both spectra exhibit similar intensities of absorption at the same wavelengths.

(2) Determine the 1H spectrum of a solution of Cefoperazone Sodium in heavy water for nuclear magnetic resonance spectroscopy (1 in 10) as directed under Nuclear Magnetic Resonance Spectroscopy <2.21>, using sodium 3-trimethylsilylpropanesulfonate for nuclear magnetic resonance spectroscopy as an internal reference compound: it exhibits a triplet signal A at around δ 1.2 ppm, a doublet signal B at around δ 6.8 ppm, and a doublet signal C at around δ 7.3 ppm. The ratio of integrated intensity of these signals, A:B:C, is about 3:2:2.

(3) Cefoperazone Sodium responds to the Qualitative Tests <1.09> (1) for sodium salt.

Optical rotation <2.49> $[\alpha]_D^{20}$: -15 – -25° (1 g, water, 100 mL, 100 mm).

pH <2.54> Dissolve 1.0 g of Cefoperazone Sodium in 4 mL of water: the pH of the solution is between 4.5 and 6.5.

Purity (1) Clarity and color of solution—Dissolve 1.0 g of Cefoperazone Sodium in 10 mL of water: the solution is clear, and its absorbance at 400 nm, determined as directed under Ultraviolet-visible Spectrophotometry <2.24>, is not more than 0.18.

(2) Heavy metals <1.07>—Proceed with 1.0 g of Cefoperazone Sodium according to Method 4, and perform the test. Prepare the control solution with 2.0 mL of Standard Lead Solution (not more than 20 ppm).

(3) Arsenic <1.11>—Prepare the test solution with 1.0 g of Cefoperazone Sodium according to Method 4, and perform the test (not more than 2 ppm).

(4) Related substances—Dissolve 0.1 g of Cefoperazone

Sodium in 100 mL of water, and use this solution as the sample solution. Pipet 1 mL of the sample solution, add water to make exactly 50 mL, and use this solution as the standard solution. Perform the test with exactly 25 μ L each of the sample solution and standard solution as directed under Liquid Chromatography <2.01> according to the following conditions, and determine each peak area by the automatic integration method. Calculate the percentages of each peak area obtained from the sample solution against 50 times of the peak area of cefoperazone from the standard solution: the related substance I with the retention time of about 8 minutes is not more than 5.0%, the related substance II with that of about 17 minutes is not more than 1.5%, and the total amount of all related substances is not more than 7.0%. For the peak areas of the related substances I and II, multiply their correction factors, 0.90 and 0.75, respectively.

Operating conditions—

Detector, column, column temperature, mobile phase, and flow rate: Proceed as directed in the operating conditions in the Assay.

Time span of measurement: About 3 times as long as the retention time of cefoperazone, beginning after the solvent peak.

System suitability—

Test for required detectability: Pipet 1 mL of the standard solution, and add the mobile phase to make exactly 20 mL. Confirm that the peak area of cefoperazone obtained with 25 μ L of this solution is equivalent to 3.5 to 6.5% of that with 25 μ L of the standard solution.

System performance: When the procedure is run with 25 μ L of the standard solution under the above operating conditions, the number of theoretical plates and the symmetry factor of the peak of cefoperazone are not less than 5000 and not more than 1.5, respectively.

System repeatability: When the test is repeated 6 times with 25 μ L of the standard solution under the above operating conditions, the relative standard deviation of the peak areas of cefoperazone is not more than 2.0%.

Water <2.48> Not more than 1.0% (3 g, volumetric titration, direct titration).

Assay Weigh accurately an amount of Cefoperazone Sodium equivalent to about 0.1 g (potency), and dissolve in water to make exactly 100 mL. Pipet 5 mL of this solution, add exactly 5 mL of the internal standard solution, and use this solution as the sample solution. Separately, weigh accurately an amount of Cefoperazone RS equivalent to about 20 mg (potency), dissolve in 1 mL of 0.1 mol/L phosphate buffer solution (pH 7.0) and add water to make exactly 20 mL. Pipet 5 mL of this solution, add exactly 5 mL of the internal standard solution, and use this solution as the standard solution. Perform the test with 10 μ L each of the sample solution and standard solution as directed under Liquid Chromatography <2.01> according to the following conditions, and calculate the ratios, Q_T and Q_S , of the peak area of cefoperazone to that of the internal standard.

$$\text{Amount } [\mu\text{g (potency)}] \text{ of cefoperazone } (C_{25}H_{27}N_9O_8S_2) \\ = M_S \times Q_T / Q_S \times 5000$$

M_S : Amount [mg (potency)] of Cefoperazone RS taken

Internal standard solution—A solution of acetanilide in a mixture of water and acetonitrile (43:7) (3 in 8000).

Operating conditions—

Detector: An ultraviolet absorption photometer (wavelength: 254 nm).

Column: A stainless steel column 4.6 mm in inside diame-

ter and 15 cm in length, packed with octadecylsilanized silica gel for liquid chromatography (5 μ m in particle diameter).

Column temperature: A constant temperature of about 35°C.

Mobile phase: To 57 mL of acetic acid (100) add 139 mL of triethylamine and water to make 1000 mL. To 20 mL of this solution add 835 mL of water, 140 mL of acetonitrile and 5 mL of dilute acetic acid.

Flow rate: Adjust so that the retention time of cefoperazone is about 10 minutes.

System suitability—

System performance: When the procedure is run with 10 μ L of the standard solution under the above operating conditions, the internal standard and cefoperazone are eluted in this order with the resolution between these peaks being not less than 5.

System repeatability: When the test is repeated 6 times with 10 μ L of the standard solution under the above operating conditions, the relative standard deviation of the ratios of the peak area of cefoperazone to that of the internal standard is not more than 1.0%.

Containers and storage Containers—Hermetic containers.

Storage—In a cold place.

Cefoperazone Sodium for Injection

注射用セフォペラゾンナトリウム

Cefoperazone Sodium for Injection is a preparation for injection which is dissolved before use.

It contains not less than 93.0% and not more than 107.0% of the labeled potency of cefoperazone ($C_{25}H_{27}N_9O_8S_2$; 645.67).

Method of preparation Prepare as directed under Injections, with Cefoperazone Sodium.

Description Cefoperazone Sodium for Injection occurs as a white to yellowish white, crystalline powder or masses.

Identification Determine the absorption spectrum of a solution of Cefoperazone Sodium for Injection (1 in 50,000) as directed under Ultraviolet-visible Spectrophotometry <2.24>: it exhibits maxima between 226 nm and 230 nm, and between 263 nm and 267 nm.

pH <2.54> The pH of a solution prepared by dissolving an amount of Cefoperazone Sodium for Injection, equivalent to 1.0 g (potency) of Cefoperazone Sodium, in 4 mL of water is between 4.5 and 6.5.

Purity (1) Clarity and color of solution—Dissolve an amount of Cefoperazone Sodium for Injection, equivalent to 1.0 g (potency) of Cefoperazone Sodium, in 10 mL of water: the solution is clear, and its absorbance at 400 nm, determined as directed under Ultraviolet-visible Spectrophotometry <2.24>, is not more than 0.22.

(2) Related substances—Dissolve an amount of Cefoperazone Sodium for Injection, equivalent to 0.1 g (potency) of Cefoperazone Sodium, in 100 mL of water, and use this solution as the sample solution. Pipet 1 mL of the sample solution, add water to make exactly 50 mL, and use this solution as the standard solution. Perform the test with exactly 25 μ L each of the sample solution and standard solution as directed under Liquid Chromatography <2.01> according to the following conditions, and determine each peak area by the automatic integration method: the peak area of related

substance I, having the relative retention time of about 0.8 to cefoperazone, obtained from the sample solution is not larger than 2.5 times the peak area of cefoperazone from the standard solution, the peak area of related substance II, having the relative retention time of about 1.7, from the sample solution is not larger than 3/4 times the peak area of cefoperazone from the standard solution. Furthermore, the total area of the peaks other than cefoperazone from the sample solution is not larger than 3.5 times the peak area of cefoperazone from the standard solution. For the peak areas of the related substances I and II, multiply their correction factors, 0.90 and 0.75, respectively.

Operating conditions—

Detector, column, column temperature, mobile phase and flow rate: Proceed as directed in the operating conditions in the Assay under Cefoperazone Sodium.

Time span of measurement: About 3 times as long as the retention time of cefoperazone, beginning after the solvent peak.

System suitability—

Proceed as directed in the system suitability in the Purity (4) under Cefoperazone Sodium.

Water <2.48> Not more than 1.0% (3 g, volumetric titration, direct titration).

Bacterial endotoxins <4.01> Less than 0.05 EU/mg (potency).

Uniformity of dosage units <6.02> It meets the requirement of the Mass variation test.

Foreign insoluble matter <6.06> Perform the test according to Method 2: it meets the requirement.

Insoluble particulate matter <6.07> It meets the requirement.

Sterility <4.06> Perform the test according to the Membrane filtration method: it meets the requirement.

Assay Weigh accurately the mass of the contents of not less than 10 Cefoperazone Sodium for Injection. Weigh accurately a portion of the content, equivalent to about 0.1 g (potency) of Cefoperazone Sodium, and dissolve in water to make exactly 100 mL. Pipet 5 mL of this solution, add exactly 5 mL of the internal standard solution, and use this solution as the sample solution. Then, proceed as directed in the Assay under Cefoperazone Sodium.

$$\text{Amount [mg (potency)] of cefoperazone } (C_{25}H_{27}N_9O_8S_2) \\ = M_S \times Q_T / Q_S \times 5$$

M_S : Amount [mg (potency)] of Cefoperazone RS taken

Internal standard solution—A solution of acetanilide in a mixture of water and acetonitrile (43:7) (3 in 8000).

Containers and storage Containers—Hermetic containers.

Storage—In a cold place.

Shelf life 24 months after preparation.

Cefoperazone Sodium and Sulbactam Sodium for Injection

注射用セフォペラゾンナトリウム・スルバクタムナトリウム

Cefoperazone Sodium and Sulbactam Sodium for Injection is a preparation for injection which is dissolved before use.

It contains not less than 90.0% and not more than 110.0% of the labeled potency of cefoperazone ($C_{25}H_{27}N_9O_8S_2$: 645.67), and not less than 95.0% and not more than 110.0% of the labeled potency of sulbactam ($C_8H_{11}NO_5S$: 233.24).

Method of Preparation Prepare as directed under Injections, with Cefoperazone Sodium and Sulbactam Sodium.

Description Cefoperazone Sodium and Sulbactam Sodium for Injection occurs as white to pale yellowish white, masses or powder.

Identification (1) The retention times of cefoperazone in the chromatogram obtained from the sample solution and the standard solution in the Assay are the same, and the peak area of cefoperazone obtained from the sample solution in the Assay is 0.8 to 1.1 times the peak area of cefoperazone obtained by the test performed with 10 μ L of the sample solution obtained in the Assay as directed under Liquid Chromatography <2.01> according to the following conditions.

Operating conditions—

Column, column temperature, mobile phase, and flow rate: Proceed as directed in the operating conditions in the Assay.

Detector: An ultraviolet absorption photometer (wavelength: 230 nm).

System suitability—

System performance: Proceed as directed in the system suitability in the Assay.

(2) The retention times of sulbactam in the chromatogram obtained from the sample solution and the standard solution in the Assay are the same, and the peak area of sulbactam obtained from the sample solution in the Assay is 1.4 to 1.9 times the peak area of sulbactam obtained by the test performed with 10 μ L of the sample solution obtained in the Assay as directed under Liquid Chromatography <2.01> according to the following conditions.

Operating conditions—

Column, column temperature, mobile phase, and flow rate: Proceed as directed in the operating conditions in the Assay.

Detector: An ultraviolet absorption photometer (wavelength: 230 nm).

System suitability—

System performance: Proceed as directed in the system suitability in the Assay.

pH <2.54> The pH of a solution prepared by dissolving an amount of Cefoperazone Sodium and Sulbactam Sodium for Injection, equivalent to 1.0 g (potency) of Cefoperazone Sodium, in 20 mL of water is 4.5 to 6.5.

Purity (1) Clarity and color of solution—A solution of an amount of Cefoperazone Sodium and Sulbactam Sodium for Injection, equivalent to 0.5 g (potency) of Cefoperazone Sodium, in 10 mL of water is clear. Perform the test with this

solution as directed under Ultraviolet Spectrophotometry <2.24>: the absorbance at 425 nm is not more than 0.10.

(2) Related substances—Weigh accurately an amount of Cefoperazone Sodium and Sulbactam Sodium for Injection, equivalent to 0.1 g (potency) of Cefoperazone Sodium, dissolve in the mobile phase to make exactly 50 mL, and use this solution as the sample solution. Pipet 2 mL of the sample solution, add the mobile phase to make exactly 50 mL, and use this solution as the standard solution (1). Weigh accurately about 40 mg of sulbactam sodium for sulbactam penicillamine, dissolve in 2 mL of water, add 0.5 mL of sodium hydroxide TS, allow to stand at room temperature for 10 minutes, then add 0.5 mL of 1 mol/L hydrochloric acid TS, and add the mobile phase to make exactly 100 mL. Pipet 5 mL of this solution, add the mobile phase to make exactly 50 mL, and use this solution as the standard solution (2). Perform the test with exactly 10 μ L each of the sample solution and the standard solutions (1) and (2) as directed under Liquid Chromatography <2.01> according to the following conditions, and determine each peak area by the automatic integration method: the area of the peak, having a relative retention time of about 0.3 (related substance I) to cefoperazone, obtained from the sample solution is not larger than 1.75 times the peak area of cefoperazone from the standard solution (1), the area of the peak, having a relative retention time of about 0.4 (related substance III) and about 1.3 (related substance II), obtained from the sample solution is not larger than 1/2 times the peak area of cefoperazone from the standard solution (1). When determine the peak areas, A_T and A_S , of sulbactam penicillamine with the sample solution and the standard solution (2), and calculate the amount of sulbactam penicillamine by the following equation, it is not more than 1.0%. For the area of the peak of related substance III, multiply the correction factor 0.4.

$$\begin{aligned} &\text{Amount of sulbactam penicillamine (\%)} \\ &= M_S/M_T \times A_T/A_S \times 5 \end{aligned}$$

M_S : Amount (mg) of sulbactam sodium for sulbactam penicillamine taken

M_T : Amount (mg) of Cefoperazone Sodium and Sulbactam Sodium for Injection taken

Operating conditions—

Column, column temperature, mobile phase, and flow rate: Proceed as directed in the operating conditions in the Assay.

Detector: An ultraviolet absorption photometer (wavelength: 230 nm).

System suitability—

System performance: To 1 mL of the standard solution (1) add 1 mL of the standard solution (2). When the procedure is run with 10 μ L of this solution under the above operating conditions, sulbactam penicillamine, sulbactam and cefoperazone are eluted in this order with the resolutions between the peaks, sulbactam penicillamine and sulbactam, and sulbactam and cefoperazone, being not less than 4 and not less than 5, respectively.

System repeatability: When the test is repeated 6 times with 10 μ L of the standard solution (2) under the above operating conditions, the relative standard deviation of the peak area of sulbactam penicillamine is not more than 2.0%.

Water <2.48> Not more than 1.0% (1 g, volumetric titration, direct titration).

Bacterial endotoxins <4.01> Less than 0.060 EU/mg (potency).

Uniformity of dosage units <6.02> It meets the requirement

of the Mass variation test (T : 105.0%).

Foreign insoluble matter <6.06> Perform the test according to Method 2: it meets the requirement.

Insoluble particulate matter <6.07> It meets the requirement.

Sterility <4.06> Perform the test according to the Membrane filtration method: it meets the requirement.

Assay Weigh accurately the mass of the content of not less than 5 Cefoperazone Sodium and Sulbactam Sodium for Injection. Weigh accurately a portion of the content, equivalent to about 50 mg (potency) of Cefoperazone Sodium, dissolve in suitable amount of the mobile phase, add exactly 5 mL of the internal standard solution, add the mobile phase to make 50 mL, and use this solution as the sample solution. Separately, weigh accurately about 50 mg (potency) each of Sulbactam RS and Cefoperazone RS, dissolve in suitable amount of the mobile phase, add exactly 5 mL of the internal standard solution, add the mobile phase to make 50 mL, and use this solution as the standard solution. Perform the test with 10 μ L each of the sample solution and standard solution as directed under Liquid Chromatography <2.01> according to the following conditions, and calculate the ratios, Q_{Ta} and Q_{Tb} of the peak areas of sulbactam and cefoperazone to that of the internal standard obtained from the sample solution, and the ratios, Q_{Sa} and Q_{Sb} of the peak areas of sulbactam and cefoperazone to that of the internal standard obtained from the standard solution.

$$\begin{aligned} \text{Amount [mg (potency)] of sulbactam (C}_8\text{H}_{11}\text{NO}_5\text{S)} \\ = M_{S1} \times Q_{Ta}/Q_{Sa} \end{aligned}$$

$$\begin{aligned} \text{Amount [mg (potency)] of cefoperazone (C}_{25}\text{H}_{27}\text{N}_9\text{O}_8\text{S}_2) \\ = M_{S2} \times Q_{Tb}/Q_{Sb} \end{aligned}$$

M_{S1} : Amount [mg (potency)] of Sulbactam RS taken

M_{S2} : Amount [mg (potency)] of Cefoperazone RS taken

Internal standard solution—A solution of ethyl parahydroxybenzoate (7 in 1000).

Operating conditions—

Detector: An ultraviolet absorption photometer (wavelength: 220 nm).

Column: A stainless steel column 3.9 mm in inside diameter and 30 cm in length, packed with octadecylsilanized silica gel for liquid chromatography (10 μ m in particle diameter).

Column temperature: A constant temperature of about 35°C.

Mobile phase: A mixture of 0.005 mol/L tetrabutylammonium hydroxide TS and acetonitrile for liquid chromatography (3:1).

Flow rate: Adjust so that the retention time of sulbactam is about 7 minutes.

System suitability—

System performance: When the procedure is run with 10 μ L of the standard solution under the above operating conditions, sulbactam, the internal standard, and cefoperazone are eluted in this order with the resolution between these peaks being not less than 1.5.

System repeatability: When the test is repeated 6 times with 10 μ L of the standard solution under the above operating conditions, the relative standard deviation of the peak of sulbactam is not more than 1.0%.

Containers and storage Containers—Hermetic containers. Plastic containers for aqueous injections may be used.

Cefotaxime Sodium

セフトキシムナトリウム

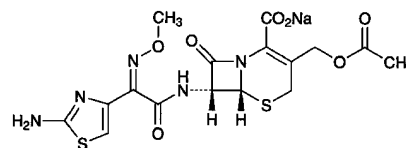

$C_{16}H_{16}N_5NaO_7S_2$: 477.45

Monosodium (6*R*,7*R*)-3-acetoxymethyl-7-[(*Z*)-2-(2-aminothiazol-4-yl)-2-(methoxyimino)acetylamino]-8-oxo-5-thia-1-azabicyclo[4.2.0]oct-2-ene-2-carboxylate
[64485-93-4]

Cefotaxime Sodium contains not less than 916 μ g (potency) and not more than 978 μ g (potency) per mg, calculated on the dried basis. The potency of Cefotaxime Sodium is expressed as mass (potency) of cefotaxime ($C_{16}H_{17}N_5O_7S_2$: 455.47).

Description Cefotaxime Sodium occurs as white to light yellow-white crystalline powder.

It is freely soluble in water, sparingly soluble in methanol, and very slightly soluble in ethanol (95).

Identification (1) Dissolve 2 mg of Cefotaxime Sodium in 0.01 mol/L hydrochloric acid TS to make 100 mL. Determine the absorption spectrum of this solution as directed under Ultraviolet-visible Spectrophotometry <2.24>, and compare the spectrum with the Reference Spectrum: both spectra exhibit similar intensities of absorption at the same wavelengths.

(2) Determine the infrared absorption spectrum of Cefotaxime Sodium as directed in the potassium bromide disk method under Infrared Spectrophotometry <2.25>, and compare the spectrum with the Reference Spectrum: both spectra exhibit similar intensities of absorption at the same wave numbers.

(3) Determine the ^1H spectrum of a solution of Cefotaxime Sodium in heavy water for nuclear magnetic resonance spectroscopy (1 in 125) as directed under Nuclear Magnetic Resonance Spectroscopy <2.21>, using sodium 3-trimethylsilylpropanesulfonate for nuclear magnetic resonance spectroscopy as an internal reference compound: it exhibits three single signals, A, B and C, at around δ 2.1 ppm, at around δ 4.0 ppm and at around δ 7.0 ppm. The ratio of the integrated intensity of each signal, A:B:C, is about 3:3:1.

(4) Cefotaxime Sodium responds to Qualitative Tests <1.09> (1) for sodium salt.

Optical rotation <2.49> $[\alpha]_D^{20}$: +58 – +64° (0.25 g calculated on the dried basis, water, 25 mL, 100 mm).

pH <2.54> The pH of a solution obtained by dissolving 1.0 g of Cefotaxime Sodium in 10 mL of water is between 4.5 and 6.5.

Purity (1) Clarity and color of solution—Dissolve 1.0 g of Cefotaxime Sodium in 10 mL of water: the solution is clear, and its absorbance at 430 nm, determined as directed under Ultraviolet-visible Spectrophotometry <2.24>, is not more than 0.40.

(2) Sulfate <1.14>—Dissolve 2.0 g of Cefotaxime Sodium in 40 mL of water, add 2 mL of dilute hydrochloric acid and water to make 50 mL, shake well, and filter. Discard first 10 mL of the filtrate, and to the subsequent 25 mL of the filtrate add water to make 50 mL. Perform the test with this

solution as the test solution. Prepare the control solution as follows: To 1.0 mL of 0.005 mol/L sulfuric acid VS add 1 mL of dilute hydrochloric acid and water to make 50 mL (not more than 0.048%).

(3) Heavy metals <1.07>—Proceed with 1.0 g of Cefotaxime Sodium according to Method 2, and perform the test. Prepare the control solution with 2.0 mL of Standard Lead Solution (not more than 20 ppm).

(4) Arsenic <1.11>—Prepare the test solution with 1.0 g of Cefotaxime Sodium according to Method 3, and perform the test (not more than 2 ppm).

(5) Related substances—Perform the test with 10 μ L of the sample solution obtained in the Assay as directed under Liquid Chromatography <2.01> according to the following conditions, and determine each peak area obtained from the chromatogram by the automatic integration method, and calculated the amounts of them by the area percentage method: the amount of the peak other than cefotaxime is not more than 1.0% and the total amount of these peaks is not more than 3.0%.

Operating conditions—

Detector, column, column temperature, mobile phase A, mobile phase B, flowing of mobile phase, and flow rate: Proceed as directed in the operating conditions in the Assay.

Time span of measurement: About 3.5 times as long as the retention time of cefotaxime, beginning after the solvent peak.

System suitability—

System performance, and system repeatability: Proceed as directed in the system suitability in the Assay.

Test for required detectability: Measure exactly 2 mL of the standard solution, and add the mobile phase A to make exactly 100 mL. Pipet 2 mL of this solution, and add the mobile phase A to make exactly 20 mL. Confirm that the peak area of cefotaxime obtained with 10 μ L of this solution is equivalent to 0.15 to 0.25% of that with 10 μ L of the standard solution.

Loss on drying <2.41> Not more than 3.0% (1 g, 105°C, 3 hours).

Assay Weigh accurately an amount of Cefotaxime Sodium and Cefotaxime RS, equivalent to about 40 mg (potency), dissolve each in the mobile phase A to make exactly 50 mL, and use these solutions as the sample solution and standard solution. Perform the test with exactly 10 μ L each of the sample solution and standard solution as directed under Liquid Chromatography <2.01> according to the following conditions, and determine the peak areas, A_T and A_S , of cefotaxime in each solution.

$$\text{Amount } [\mu\text{g (potency)}] \text{ of cefotaxime (C}_{16}\text{H}_{17}\text{N}_5\text{O}_7\text{S}_2) \\ = M_S \times A_T / A_S \times 1000$$

M_S : Amount [mg (potency)] of Cefotaxime RS taken

Operating conditions—

Detector: An ultraviolet absorption photometer (wavelength: 235 nm).

Column: A stainless steel column 4.6 mm in inside diameter and 15 cm in length, packed with octadecylsilanized silica gel for liquid chromatography (5 μ m in particle diameter).

Column temperature: A constant temperature of about 30°C.

Mobile phase A: To 0.05 mol/L disodium hydrogen phosphate TS add phosphoric acid to adjust the pH to 6.25. To 860 mL of this solution add 140 mL of methanol.

Mobile phase B: To 0.05 mol/L disodium hydrogen phosphate TS add phosphoric acid to adjust the pH to 6.25. To

600 mL of this solution add 400 mL of methanol.

Flowing of mobile phase: Control the gradient by mixing the mobile phases A and B as directed in the following table.

Time after injection of sample (min)	Mobile phase A (vol%)	Mobile phase B (vol%)
0 – 7	100	0
7 – 9	100 → 80	0 → 20
9 – 16	80	20
16 – 45	80 → 0	20 → 100
45 – 50	0	100

Flow rate: 1.3 mL per minute (the retention time of cefotaxime is about 14 minutes).

System suitability—

System performance: To 1 mL of the standard solution add 7.0 mL of water and 2.0 mL of methanol, mix, then add 25 mg of sodium carbonate decahydrate, and shake. After allowing to stand for 10 minutes, add 3 drops of acetic acid (100) and 1 mL of the standard solution, and mix. When the procedure is run with 10 μ L of this solution under the above operating conditions, desacetyl cefotaxime with the relative retention time being about 0.3 to cefotaxime and cefotaxime are eluted in this order with the resolution between these peaks being not less than 20, and the symmetry factor of the peak of cefotaxime is not more than 2.

System repeatability: When the test is repeated 6 times with 10 μ L of the standard solution under the above operating conditions, the relative standard deviation of the peak area of cefotaxime is not more than 2.0%.

Containers and storage Containers—Tight containers.

Cefotetan

セフォテタン

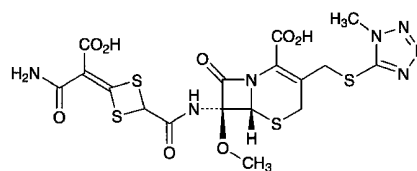

$\text{C}_{17}\text{H}_{17}\text{N}_7\text{O}_8\text{S}_4$: 575.62

(6R,7R)-7-[[4-(Carbamoylcarboxymethylidene)-1,3-dithietane-2-carbonyl]amino]-7-methoxy-3-(1-methyl-1H-tetrazol-5-ylsulfanylmethyl)-8-oxo-5-thia-1-azabicyclo[4.2.0]oct-2-ene-2-carboxylic acid [69712-56-7]

Cefotetan contains not less than 960 μ g (potency) and not more than 1010 μ g (potency) per mg, calculated on the anhydrous basis. The potency of Cefotetan is expressed as mass (potency) of cefotetan ($\text{C}_{17}\text{H}_{17}\text{N}_7\text{O}_8\text{S}_4$).

Description Cefotetan occurs as white to light yellow-white powder.

It is sparingly soluble in methanol, and slightly soluble in water and in ethanol (99.5).

Identification (1) Determine the absorption spectrum of a solution of Cefotetan in phosphate buffer solution for antibiotics, pH 6.5 (1 in 100,000) as directed under Ultraviolet-visible Spectrophotometry <2.24>, and compare the spectrum

with the Reference Spectrum or the spectrum of a solution of Cefotetan RS prepared in the same manner as the sample solution: both spectra exhibit similar intensities of absorption at the same wavelengths.

(2) Determine the infrared absorption spectrum of Cefotetan as directed in the potassium bromide disk method under Infrared Spectrophotometry <2.25>, and compare the spectrum with the Reference Spectrum or the spectrum of Cefotetan RS: both spectra exhibit similar intensities of absorption at the same wave numbers.

(3) Dissolve 50 mg of Cefotetan in 0.5 mL of a solution of sodium hydrogen carbonate in heavy water for nuclear magnetic resonance spectroscopy (1 in 25). Determine the ^1H spectrum of this solution as directed under Nuclear Magnetic Resonance Spectroscopy <2.21>, using sodium 3-trimethylsilylpropanesulfonate for nuclear magnetic resonance spectroscopy as an internal reference compound: it exhibits singlet signals, A, B, C and D, at around δ 3.6 ppm, at around δ 4.0 ppm, at around δ 5.1 ppm and at around δ 5.2 ppm, respectively. The ratio of the integrated intensity of each signal, A:B:C:D, is about 3:3:1:1.

Optical rotation <2.49> $[\alpha]_D^{20}$: +112 – +124° (0.5 g calculated on the anhydrous basis, a solution of sodium hydrogen carbonate (1 in 200), 50 mL, 100 mm).

Purity (1) Clarity and color of solution—Dissolve 1.0 g of Cefotetan in 10 mL of a solution of sodium hydrogen carbonate (1 in 30): the solution is clear, and colorless or light yellow.

(2) Heavy metals <1.07>—Proceed with 1.0 g of Cefotetan according to Method 2, and perform the test. Prepare the control solution with 2.0 mL of Standard Lead Solution (not more than 20 ppm).

(3) Related substances—Weigh accurately about 0.1 g of Cefotetan, dissolve in a suitable amount of methanol, add exactly 2 mL of the internal standard solution and methanol to make 20 mL, and use this solution as the sample solution. Separately, weigh accurately about 3 mg of 1-methyl-1*H*-tetrazole-5-thiol for liquid chromatography, previously dried in a desiccator (in vacuum, silica gel) for 2 hours, and about 2 mg of Cefotetan RS, calculated on the anhydrous basis, dissolve in methanol to make exactly 20 mL. Pipet 2 mL of this solution, add exactly 2 mL of the internal standard solution and methanol to make 20 mL, and use this solution as the standard solution. Perform the test with 5 μL of the sample solution and standard solution as directed under Liquid Chromatography <2.01> according to the following conditions, and calculate the ratios, Q_{Ta} , Q_{Tb} , Q_{Tc} , Q_{Td} , Q_{Te} and Q_{Tf} , of the peak areas of 1-methyl-1*H*-tetrazole-5-thiol, cefotetan lactone having the relative retention time of about 0.5 to cefotetan, Δ_2 -cefotetan having the relative retention time of about 1.2, isothiazole substance having the relative retention time of about 1.3, each of other related substances and the total of other related substances, to the peak area of the internal standard, respectively, obtained from the sample solution, and the ratios, Q_{Sa} and Q_{Sb} , of the peak areas of 1-methyl-1*H*-tetrazole-5-thiol and cefotetan, to the peak area of the internal standard, respectively, from the standard solution. Calculate the amount of 1-methyl-1*H*-tetrazole-5-thiol, cefotetan lactone, Δ_2 -cefotetan, isothiazole substance, each of other related substances and the total of other related substances from the following equations: the amount of 1-methyl-1*H*-tetrazole-5-thiol is not more than 0.3%, cefotetan lactone is not more than 0.3%, Δ_2 -cefotetan is not more than 0.5%, isothiazole substance is not more than 0.5%, each of other related substances is not more than 0.2% and the total of other related substances is not more

than 0.4%.

$$\begin{aligned} & \text{1-Methyl-1H-tetrazole-5-thiol (\%)} \\ & = M_{\text{Sa}}/M_{\text{T}} \times Q_{\text{Ta}}/Q_{\text{Sa}} \times 1/100 \end{aligned}$$

$$\begin{aligned} & \text{Cefotetan lactone (\%)} \\ & = M_{\text{Sb}}/M_{\text{T}} \times Q_{\text{Tb}}/Q_{\text{Sb}} \times 1/100 \end{aligned}$$

$$\begin{aligned} & \Delta_2\text{-Cefotetan (\%)} \\ & = M_{\text{Sb}}/M_{\text{T}} \times Q_{\text{Tc}}/Q_{\text{Sb}} \times 1/100 \end{aligned}$$

$$\begin{aligned} & \text{Isothiazole substance (\%)} \\ & = M_{\text{Sb}}/M_{\text{T}} \times Q_{\text{Td}}/Q_{\text{Sb}} \times 1/100 \end{aligned}$$

$$\begin{aligned} & \text{Each of other related substances (\%)} \\ & = M_{\text{Sb}}/M_{\text{T}} \times Q_{\text{Te}}/Q_{\text{Sb}} \times 1/100 \end{aligned}$$

$$\begin{aligned} & \text{Total of other related substances (\%)} \\ & = M_{\text{Sb}}/M_{\text{T}} \times Q_{\text{Tf}}/Q_{\text{Sb}} \times 1/100 \end{aligned}$$

M_{Sa} : Amount (mg) of 1-methyl-1*H*-tetrazole-5-thiol taken

M_{Sb} : Amount (mg) of Cefotetan RS, calculated on the anhydrous basis taken

M_{T} : Amount (g) of Cefotetan taken

Internal standard solution—A solution of anhydrous caffeine in methanol (3 in 10,000).

Operating conditions—

Detector, column, column temperature, mobile phase, and flow rate: Proceed as directed in the operating conditions in the Assay.

Time span of measurement: About 3.5 times as long as the retention time of cefotetan.

System suitability—

System performance: Proceed as directed in the system suitability in the Assay.

Test for required detectability: Measure exactly 15 mL of the standard solution, and add methanol to make exactly 100 mL. Confirm that the peak area of cefotetan obtained with 5 μL of this solution is equivalent to 12 to 18% of that with 5 μL of the standard solution.

System repeatability: When the test is repeated 6 times with 5 μL of the standard solution under the above operating conditions, the relative standard deviation of the ratio of the peak area of cefotetan to that of the internal standard is not more than 2.0%.

Water <2.48> Not more than 2.5% (1 g, volumetric titration, direct titration).

Residue on ignition <2.44> Not more than 0.1% (1 g).

Isomer ratio Dissolve 10 mg of Cefotetan in 20 mL of methanol, and use this solution as the sample solution. Perform the test with 5 μL of the sample solution as directed under Liquid Chromatography <2.01> according to the following conditions, and determine each peak area by the automatic integration method. Calculate the amount of the adjacent two peaks appeared at around the retention time of 40 minutes, one having shorter retention time is *l*-substance and another having longer retention time is *d*-substance, by the area percentage method: the amount of *l*-substance is not less than 35% and not more than 45%.

Operating conditions—

Detector: An ultraviolet absorption photometer (wavelength: 254 nm).

Column: A stainless steel column 4 mm in inside diameter and 15 cm in length, packed with octadecylsilanized silica gel for liquid chromatography (5 μm in particle diameter).

Column temperature: A constant temperature of about 40°C.

Mobile phase: A mixture of 0.1 mol/L phosphate buffer

solution (pH 7.0), water and a solution of tetrabutylammonium hydrogensulfate in acetonitrile (1 in 150) (9:9:2).

Flow rate: Adjust so that the retention time of *l*-substance is about 40 minutes.

System suitability—

System performance: When the procedure is run with 5 μ L of the sample solution under the above operating conditions, *l*-substance and *d*-substance are eluted in this order with the resolution between these peaks being not less than 1.5.

System repeatability: To exactly 1 mL of the sample solution add methanol to make exactly 10 mL. When the test is repeated 6 times with 5 μ L of this solution under the above operating conditions, the relative standard deviation of the peak area of *l*-substance is not more than 5.0%.

Assay Weigh accurately an amount of Cefotetan and Cefotetan RS, equivalent to about 50 mg (potency), and dissolve each in phosphate buffer solution for antibiotics, pH 6.5 to make exactly 50 mL. Pipet 15 mL each of these solutions, add exactly 10 mL of the internal standard solution and phosphate buffer solution for antibiotics, pH 6.5 to make 50 mL, and use these solutions as the sample solution and standard solution. Perform the test with 5 μ L each of the sample solution and standard solution as directed under Liquid Chromatography <2.01> according to the following conditions, and calculate the ratios, Q_T and Q_S , of the peak area of cefotetan to that of the internal standard.

$$\text{Amount } [\mu\text{g (potency)}] \text{ of cefotetan (C}_{17}\text{H}_{17}\text{N}_7\text{O}_8\text{S}_4) \\ = M_S \times Q_T / Q_S \times 1000$$

M_S : Amount [mg (potency)] of Cefotetan RS taken

Internal standard solution—A solution of anhydrous caffeine (1 in 1000).

Operating conditions—

Detector: An ultraviolet absorption photometer (wavelength: 254 nm).

Column: A stainless steel column 4.6 mm in inside diameter and 15 cm in length, packed with octadecylsilanized silica gel for liquid chromatography (5 μ m in particle diameter).

Column temperature: A constant temperature of about 40°C.

Mobile phase: Dissolve 11.53 g of phosphoric acid in 1000 mL of water. To 850 mL of this solution add 50 mL of acetonitrile, 50 mL of acetic acid (100) and 50 mL of methanol.

Flow rate: Adjust so that the retention time of cefotetan is about 17 minutes.

System suitability—

System performance: When the procedure is run with 5 μ L of the standard solution under the above operating conditions, the internal standard and cefotetan are eluted in this order with the resolution between these peaks being not less than 8.

System repeatability: When the test is repeated 5 times with 5 μ L of the standard solution under the above operating conditions, the relative standard deviation of the ratio of the peak area of cefotetan to that of the internal standard is not more than 1.0%.

Containers and storage Containers—Tight containers.

Storage—Light-resistant, and at a temperature not exceeding 5°C.

Cefotiam Hexetil Hydrochloride

セフォチアム ヘキセチル塩酸塩

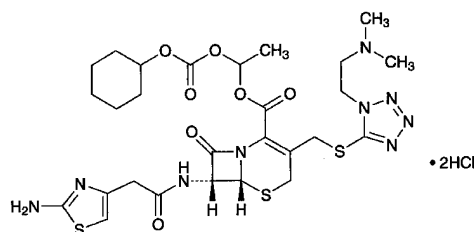

$\text{C}_{27}\text{H}_{37}\text{N}_9\text{O}_7\text{S}_3 \cdot 2\text{HCl}$: 768.76

(1*RS*)-1-Cyclohexyloxycarbonyloxyethyl (6*R*,7*R*)-7-[2-(2-aminothiazol-4-yl)acetyl-amino]-3-[1-(2-dimethylaminoethyl)-1*H*-tetrazol-5-ylsulfanyl-methyl]-8-oxo-5-thia-1-azabicyclo[4.2.0]oct-2-ene-2-carboxylate dihydrochloride

[95789-30-3]

Cefotiam Hexetil Hydrochloride contains not less than 615 μ g (potency) and not more than 690 μ g (potency) per mg, calculated on the anhydrous basis. The potency of Cefotiam Hexetil Hydrochloride is expressed as mass (potency) of cefotiam ($\text{C}_{18}\text{H}_{23}\text{N}_9\text{O}_4\text{S}_3$: 525.63).

Description Cefotiam Hexetil Hydrochloride occurs as a white to light yellow powder.

It is very soluble in water, in methanol and in ethanol (95), freely soluble in dimethylsulfoxide, and slightly soluble in acetonitrile.

It dissolves in 0.1 mol/L hydrochloric acid TS.

It is hygroscopic.

Identification (1) Determine the absorption spectrum of a solution of Cefotiam Hexetil Hydrochloride in 0.1 mol/L hydrochloric acid TS (3 in 125,000) as directed under Ultraviolet-visible Spectrophotometry <2.24>, and compare the spectrum with the Reference Spectrum or the spectrum of a solution of Cefotiam Hexetil Hydrochloride RS prepared in the same manner as the sample solution: both spectra exhibit similar intensities of absorption at the same wavelengths.

(2) Determine the ^1H spectrum of a solution of Cefotiam Hexetil Hydrochloride in deuterated dimethylsulfoxide for nuclear magnetic resonance spectroscopy (1 in 20) as directed under Nuclear Magnetic Resonance Spectroscopy <2.21>, using tetramethylsilane for nuclear magnetic resonance spectroscopy as an internal reference compound: it exhibits two singlet signals, A and B, at around δ 2.8 ppm and at around δ 6.6 ppm, and a multiplet signal, C, at around δ 6.9 ppm. The ratio of the integrated intensity of each signal, A:B:C, is about 6:1:1.

(3) To a solution of Cefotiam Hexetil Hydrochloride (1 in 200) add 2 mL of dilute nitric acid and 1 mL of silver nitrate TS, and mix: a white precipitate is formed.

Optical rotation <2.49> $[\alpha]_D^{20}$: +52 – +60° (0.1 g calculated on the anhydrous basis, 0.1 mol/L hydrochloric acid TS, 10 mL, 100 mm).

Purity (1) Heavy metals <1.07>—Proceed with 2.0 g of Cefotiam Hexetil Hydrochloride according to Method 2, and perform the test. Prepare the control solution with 2.0 mL of Standard Lead Solution (not more than 10 ppm).

(2) Arsenic <1.11>—Prepare the test solution with 2.0 g of Cefotiam Hexetil Hydrochloride according to Method 3,

and perform the test, using a solution of magnesium nitrate hexahydrate in ethanol (95) (1 in 5) (not more than 1 ppm).

(3) Related substance 1—Weigh accurately about 50 mg of Cefotiam Hexetil Hydrochloride, and dissolve in a mixture of diluted phosphoric acid (1 in 100) and acetonitrile (4:1) to make exactly 50 mL. Pipet 10 mL of this solution, add a mixture of diluted phosphoric acid (1 in 100) and acetonitrile (4:1) to make exactly 25 mL, and use this solution as the sample solution. Separately, weigh accurately about 50 mg of Cefotiam Hexetil Hydrochloride RS, and dissolve in a mixture of diluted phosphoric acid (1 in 100) and acetonitrile (4:1) to make exactly 50 mL. Pipet 1 mL of this solution, add a mixture of diluted phosphoric acid (1 in 100) and acetonitrile (4:1) to make exactly 50 mL, and use this solution as the standard solution. Perform the test with exactly 10 μ L each of the sample solution and standard solution as directed under Liquid Chromatography <2.01> according to the following conditions, and determine each peak area by the automatic integration method. Calculate the amount of the related substances by the following equation: the amount of the related substance having the relative retention time of about 1.2 to one of the peaks of cefotiam hexetil, which has the larger retention time, is not more than 2.0%, and each amount of the other related substances is not more than 0.5%. For the peak area, having the relative retention time of about 1.2 to one of the peaks of cefotiam hexetil, which has the larger retention time, multiply the correction factor, 0.78.

$$\begin{aligned} &\text{Amount (\%)} \text{ of related substance} \\ &= M_S/M_T \times A_T/A_S \times 5 \end{aligned}$$

M_S : Amount (g) of Cefotiam Hexetil Hydrochloride RS taken

M_T : Amount (g) of Cefotiam Hexetil Hydrochloride taken

A_S : Total of two peak areas of cefotiam hexetil from the standard solution

A_T : Each peak area of related substance from the sample solution

Operating conditions—

Detector: An ultraviolet absorption photometer (wavelength: 254 nm).

Column: A stainless steel column 4 mm in inside diameter and 15 cm in length, packed with octadecylsilylated silica gel for liquid chromatography (5 μ m in particle diameter).

Column temperature: A constant temperature of about 25°C.

Mobile phase A: A mixture of diluted 0.2 mol/L potassium dihydrogen phosphate TS (1 in 2), acetonitrile and acetic acid (100) (72:28:1).

Mobile phase B: A mixture of acetonitrile, diluted 0.2 mol/L potassium dihydrogen phosphate TS (1 in 2) and acetic acid (100) (60:40:1).

Flowing of mobile phase: Adjust so that the mixing rate of the mobile phase A and the mobile phase B is changed linearly from 1:0 to 0:1 for 30 minutes.

Flow rate: 0.7 mL per minute.

Time span of measurement: As long as about 3 times of the retention time of one of the cefotiam hexetil peaks, which appears first, beginning after the solvent peak.

System suitability—

Test for required detectability: Measure exactly 1 mL of the standard solution, and add a mixture of diluted phosphoric acid (1 in 100) and acetonitrile (4:1) to make exactly 50 mL. Confirm that each area of the two peaks of cefotiam hexetil obtained with 10 μ L of this solution is equivalent to 1.6 to 2.4% of that with 10 μ L of the standard solution.

System performance: When the procedure is run with 10 μ L of the standard solution under the above operating conditions, the resolution between the two peaks of cefotiam hexetil is not less than 2.0.

System repeatability: When the test is repeated 6 times with 10 μ L of the standard solution under the above operating conditions, the relative standard deviation of the total of the two peak areas of cefotiam hexetil is not more than 2.0%.

(4) Related substance 2—Weigh accurately about 20 mg of Cefotiam Hexetil Hydrochloride, dissolve in 2 mL of methanol, add a mixture of a solution of diammonium hydrogen phosphate (79 in 20,000) and acetic acid (100) (200:3) to make exactly 50 mL, and use this solution as the sample solution. Separately, weigh accurately about 25 mg of Cefotiam Hydrochloride RS, and dissolve in the mobile phase to make exactly 50 mL. Pipet 2 mL of this solution, add the mobile phase to make exactly 50 mL, and use this solution as the standard solution. Perform the test with exactly 10 μ L each of the sample solution and standard solution as directed under Liquid Chromatography <2.01> according to the following conditions, and determine each peak area by the automatic integration method. Calculate the amount of the related substances by the following equation: the amounts of the related substances having the relative retention time of about 0.1 and about 0.9 are not more than 1.0%, respectively, and each amount of the related substances other than the related substances having the relative retention time of about 0.1 and about 0.9 is not more than 0.5%. For the peak area, having the relative retention time of about 0.9 to cefotiam, multiply the correction factor, 0.76.

$$\begin{aligned} &\text{Amount (\%)} \text{ of related substance} \\ &= M_S/M_T \times A_T/A_S \times 4 \end{aligned}$$

M_S : Amount (g) of Cefotiam Hydrochloride RS taken

M_T : Amount (g) of Cefotiam Hexetil Hydrochloride taken

A_S : Peak area of cefotiam from the standard solution

A_T : Each peak area from the sample solution

Operating conditions—

Detector: An ultraviolet absorption photometer (wavelength: 254 nm).

Column: A stainless steel column 4 mm in inside diameter and 15 cm in length, packed with octadecylsilylated silica gel for liquid chromatography (5 μ m in particle diameter).

Column temperature: A constant temperature of about 25°C.

Mobile phase: A mixture of a solution of diammonium hydrogen phosphate (79 in 20,000), methanol and acetic acid (100) (200:10:3).

Flow rate: Adjust so that the retention time of cefotiam is about 15 minutes.

Time span of measurement: As long as about 2 times of the retention time of cefotiam, beginning after the solvent peak.

System suitability—

Test for required detectability: Measure exactly 1 mL of the standard solution, and add the mobile phase to make exactly 50 mL. Confirm that the peak area of cefotiam obtained with 10 μ L of this solution is equivalent to 1.6 to 2.4% of that with 10 μ L of the standard solution.

System performance: To 1 mL of a solution of acetaminophen in the mobile phase (1 in 50,000) add 3 mL of the standard solution, and mix well. When the procedure is run with 10 μ L of this solution under the above operating conditions, acetaminophen and cefotiam are eluted in this order

with the resolution between these peaks being not less than 4.

System repeatability: When the test is repeated 6 times with 10 μL of the standard solution under the above operating conditions, the relative standard deviation of the peak area of cefotiam is not more than 2.0%.

(5) Total amount of related substances—The total of the amount of related substances obtained in the Related substance 1 and the Related substance 2 is not more than 6.5%.

Water <2.48> Not more than 3.5% (0.1 g, volumetric titration, direct titration).

Residue on ignition <2.44> Not more than 0.1% (1 g).

Isomer ratio Proceed the test with 20 μL of the sample solution obtained in the Assay as directed under Liquid Chromatography <2.01> according to the conditions directed in the Assay, and determine the areas of the two peaks, A_a for the faster peak and A_b for the later peak, closely appeared each other at the retention time of around 10 minutes: $A_a/(A_a + A_b)$ is not less than 0.45 and not more than 0.55.

Assay Weigh accurately an amount of Cefotiam Hexetil Hydrochloride and Cefotiam Hexetil Hydrochloride RS, equivalent to about 30 mg (potency), and dissolve each in a mixture of diluted phosphoric acid (1 in 100) and acetonitrile (4:1) to make exactly 50 mL. Measure exactly 5 mL each of these solutions, add exactly 5 mL of the internal standard solution and a mixture of diluted phosphoric acid (1 in 100) and acetonitrile (4:1) to make 50 mL, and use these solutions as the sample solution and standard solution. Perform the test with 20 μL each of the sample solution and standard solution as directed under Liquid Chromatography <2.01> according to the following conditions, and calculate the ratios, Q_T and Q_S , of the peak area of cefotiam hexetil to that of the internal standard. For this calculation, the total of the areas of the two peaks appeared closely each other at the retention time of around 10 minutes is used as the peak area of cefotiam hexetil.

$$\begin{aligned} \text{Amount } [\mu\text{g (potency)}] \text{ of cefotiam } (\text{C}_{18}\text{H}_{23}\text{N}_9\text{O}_4\text{S}_3) \\ = M_S \times Q_T/Q_S \times 1000 \end{aligned}$$

M_S : Amount [mg (potency)] of Cefotiam Hexetil Hydrochloride RS taken

Internal standard solution—A solution of benzoic acid in a mixture of diluted phosphoric acid (1 in 100) and acetonitrile (4:1) (7 in 10,000).

Operating conditions—

Detector: An ultraviolet absorption photometer (wavelength: 254 nm).

Column: A stainless steel column 4 mm in inside diameter and 15 cm in length, packed with octadecylsilanized silica gel for liquid chromatography (5 μm in particle diameter).

Column temperature: A constant temperature of about 25°C.

Mobile phase: A mixture of diluted 0.2 mol/L potassium dihydrogen phosphate TS (1 in 2), acetonitrile and acetic acid (100) (72:28:1).

Flow rate: Adjust so that the retention time of the faster peak of cefotiam hexetil is about 9 minutes.

System suitability—

System performance: When the procedure is run with 20 μL of the standard solution under the above operating conditions, the internal standard and cefotiam hexetil are eluted in this order with the resolution between the two peaks of cefotiam hexetil being not less than 2.0.

System repeatability: When the test is repeated 6 times with 20 μL of the standard solution under the above operat-

ing conditions, the relative standard deviation of the ratios of the peak area of cefotiam hexetil to that of the internal standard is not more than 1.0%.

Containers and storage Containers—Tight containers.

Cefotiam Hydrochloride

セフォチアム塩酸塩

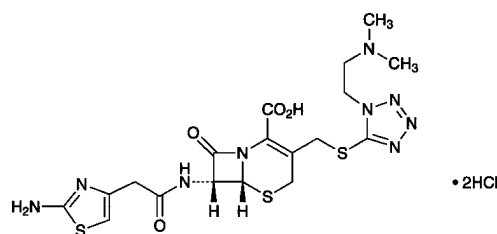

$\text{C}_{18}\text{H}_{23}\text{N}_9\text{O}_4\text{S}_3 \cdot 2\text{HCl}$: 598.55

(6*R*,7*R*)-7-[2-(2-Aminothiazol-4-yl)acetyl-amino]-3-[1-(2-dimethylaminoethyl)-1*H*-tetrazol-5-ylsulfanylmethyl]-8-oxo-5-thia-1-azabicyclo[4.2.0]oct-2-ene-2-carboxylic acid dihydrochloride

[66309-69-1]

Cefotiam Hydrochloride contains not less than 810 μg (potency) and not more than 890 μg (potency) per mg, calculated on the anhydrous basis. The potency of Cefotiam Hydrochloride is expressed as mass (potency) of cefotiam ($\text{C}_{18}\text{H}_{23}\text{N}_9\text{O}_4\text{S}_3$: 525.63).

Description Cefotiam Hydrochloride occurs as white to light yellow, crystals or crystalline powder.

It is freely soluble in water, in methanol and in formamide, slightly soluble in ethanol (95), and practically insoluble in acetonitrile.

Identification (1) Determine the absorption spectrum of a solution of Cefotiam Hydrochloride (1 in 50,000) as directed under Ultraviolet-visible Spectrophotometry <2.24>, and compare the spectrum with the Reference Spectrum or the spectrum of a solution of Cefotiam Hydrochloride RS prepared in the same manner as the sample solution: both spectra exhibit similar intensities of absorption at the same wavelengths.

(2) Determine the infrared absorption spectrum of Cefotiam Hydrochloride as directed in the potassium chloride disk method under Infrared Spectrophotometry <2.25>, and compare the spectrum with the Reference Spectrum or the spectrum of Cefotiam Hydrochloride RS: both spectra exhibit similar intensities of absorption at the same wave numbers.

(3) Determine the ^1H spectrum of a solution of Cefotiam Hydrochloride in heavy water for nuclear magnetic resonance spectroscopy (1 in 10) as directed under Nuclear Magnetic Resonance Spectroscopy <2.21>, using sodium 3-trimethylsilylpropanesulfonate for nuclear magnetic resonance spectroscopy as an internal reference compound: it exhibits singlet signals, A and B, at around δ 3.1 ppm and at around δ 6.7 ppm, respectively. The ratio of integrated intensity of each signal, A:B, is about 6:1.

(4) Dissolve 0.1 g of Cefotiam Hydrochloride in 5 mL of dilute nitric acid, and immediately add 1 mL of silver nitrate TS: a white precipitate is formed.

Optical rotation <2.49> $[\alpha]_D^{20}$: +60 – +72° (1 g calculated on the anhydrous bases, water, 100 mL, 100 mm).

pH <2.54> Dissolve 1.0 g of Cefotiam Hydrochloride in 10 mL of water: the pH of the solution is between 1.2 and 1.7.

Purity (1) Clarity and color of solution—Dissolve 1.0 g of Cefotiam Hydrochloride in 10 mL of water: the solution is clear, and colorless to yellow.

(2) Heavy metals <1.07>—To 1.0 g of Cefotiam Hydrochloride add 1 mL of sulfuric acid, and heat gently to carbonize. After cooling, add 10 mL of a solution of magnesium nitrate hexahydrate in ethanol (95) (1 in 10), fire the ethanol to burn, then heat gradually to incinerate. If a carbonized residue still retains, moisten the residue with a little amount of sulfuric acid, and ignite again to incinerate. After cooling, add 2 mL of hydrochloric acid to the residue, heat on a water bath to dissolve, then heat to dryness. Add 10 mL of water, and heat to dissolve. After cooling, add ammonia TS dropwise to adjust to pH 3–4, if necessary, filter, wash the residue on the filter with 10 mL of water, transfer the filtrate and washings into a Nessler tube, add water to make 50 mL, and use this solution as the test solution. Prepare the control solution with 2.0 mL of Standard Lead Solution in the same manner as for preparation of the test solution (not more than 20 ppm).

(3) Arsenic <1.11>—Incinerate 1.0 g of Cefotiam Hydrochloride according to Method 4. After cooling, add 10 mL of dilute hydrochloric acid to the residue, heat to dissolve on the water bath, and use this solution as the test solution. Perform the test (not more than 2 ppm).

Water <2.48> Not more than 7.0% (0.25 g, volumetric titration, direct titration. Use a mixture of formamide for water determination and methanol for water determination (2:1) instead of methanol for water determination).

Assay Weigh accurately an amount of Cefotiam Hydrochloride and Cefotiam Hydrochloride RS, equivalent to about 0.1 g (potency), and dissolve each in the mobile phase to make exactly 100 mL, and use these solutions as the sample solution and the standard solution, respectively. Perform the test with exactly 10 μ L each of the sample solution and standard solution as directed under Liquid Chromatography <2.01> according to the following conditions, and determine the peak areas, A_T and A_S , of cefotiam in each solution.

$$\begin{aligned} &\text{Amount } [\mu\text{g (potency)}] \text{ of cefotiam } (\text{C}_{18}\text{H}_{23}\text{N}_9\text{O}_4\text{S}_3) \\ &= M_S \times A_T / A_S \times 1000 \end{aligned}$$

M_S : Amount [mg (potency)] of Cefotiam Hydrochloride RS taken

Operating conditions—

Detector: An ultraviolet absorption photometer (wavelength: 254 nm).

Column: A stainless steel column 4.0 mm in inside diameter and 125 mm in length, packed with octadecylsilanized silica gel for liquid chromatography (5 μ m in particle diameter).

Column temperature: A constant temperature of about 25°C.

Mobile phase: To 800 mL of 0.05 mol/L disodium hydrogenphosphate TS add 0.05 mol/L potassium dihydrogenphosphate TS to adjust the pH to 7.7. To 440 mL of this solution add 60 mL of acetonitrile.

Flow rate: Adjust so that the retention time of cefotiam is about 14 minutes.

System suitability—

System performance: Dissolve 0.04 g of orcine in 10 mL of the standard solution. When the procedure is run with 10 μ L of the standard solution under the above operating conditions, orcine and cefotiam are eluted in this order with the

resolution between these peaks being not less than 5.

System repeatability: When the test is repeated 6 times with 10 μ L of the standard solution under the above operating conditions, the relative standard deviation of the peak areas of cefotiam is not more than 1.0%.

Containers and storage Containers—Hermetic containers.

Cefotiam Hydrochloride for Injection

注射用セフトリアム塩酸塩

Cefotiam Hydrochloride for Injection is a preparation for injection which is dissolved before use.

It contains not less than 90.0% and not more than 110.0% of the labeled potency of cefotiam ($\text{C}_{18}\text{H}_{23}\text{N}_9\text{O}_4\text{S}_3$; 525.63).

Method of Preparation Prepare as directed under Injection, with Cefotiam Hydrochloride.

Description Cefotiam Hydrochloride for Injection occurs as a white to light yellow powder.

Identification (1) Determine the absorption spectrum of a solution of Cefotiam Hydrochloride for Injection (1 in 50,000) as directed under Ultraviolet-visible Spectrophotometry <2.24>: it exhibits a maximum between 257 nm and 261 nm.

(2) Determine the ^1H spectrum of a solution of Cefotiam Hydrochloride for Injection in heavy water for nuclear magnetic resonance spectroscopy (1 in 10) as directed under Nuclear Magnetic Resonance Spectroscopy <2.21>, using sodium 3-trimethylsilylpropanesulfonate for nuclear magnetic resonance spectroscopy as an internal reference compound: it exhibits a singlet signal A between δ 2.7 ppm and δ 3.0 ppm, and a singlet signal B at around δ 6.5 ppm. The ratio of the integrated intensity of each signal, A:B, is about 6:1.

pH <2.54> The pH of a solution prepared by dissolving an amount of Cefotiam Hydrochloride for Injection, equivalent to 0.5 g (potency), in 5 mL of water is between 5.7 and 7.2.

Purity Clarity and color of solution—Dissolve an amount of Cefotiam Hydrochloride for Injection, equivalent to 1.0 g (potency) of Cefotiam Hydrochloride, in 10 mL of water: the solution is clear, and the absorbance of this solution, determined at 450 nm 10 minutes after dissolving as directed under Ultraviolet-visible Spectrophotometry <2.24>, is not more than 0.20.

Loss on drying <2.41> Not more than 6.0% (0.5 g, in vacuum, 60°C, 3 hours).

Bacterial endotoxins <4.01> Less than 0.125 EU/mg (potency).

Uniformity of dosage units <6.02> It meets the requirement of the Mass variation test.

Foreign insoluble matter <6.06> Perform the test according to Method 2: it meets the requirement.

Insoluble particulate matter <6.07> It meets the requirement.

Sterility <4.06> Perform the test according to the Membrane filtration method: it meets the requirement.

Assay Weigh accurately the contents of not less than 10

Cefotiam Hydrochloride for Injection. Weigh accurately an amount of the content, equivalent to about 50 mg (potency) of Cefotiam Hydrochloride, dissolve in the mobile phase to make exactly 50 mL, and use this solution as the sample solution. Separately, weigh accurately about 50 mg (potency) of Cefotiam Hydrochloride RS, dissolve in the mobile phase to make exactly 50 mL, and use this solution as the standard solution. Proceed as directed in the Assay under Cefotiam Hydrochloride.

$$\text{Amount } [\mu\text{g (potency)}] \text{ of cefotiam (C}_{18}\text{H}_{23}\text{N}_9\text{O}_4\text{S}_3) \\ = M_S \times A_T/A_S \times 1000$$

M_S : Amount [mg (potency)] of Cefotiam Hydrochloride RS taken

Containers and storage Containers—Hermetic containers. Plastic containers for aqueous injections may be used.

Cefozopran Hydrochloride

セフォゾプラン塩酸塩

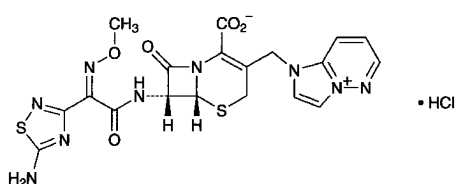

$\text{C}_{19}\text{H}_{17}\text{N}_9\text{O}_5\text{S}_2 \cdot \text{HCl}$: 551.99

(6R,7R)-7-[(Z)-2-(5-Amino-1,2,4-thiadiazol-3-yl)-2-(methoxyimino)acetyl]amino-3-(1H-imidazo[1,2-b]pyridazin-4-ium-1-ylmethyl)-8-oxo-5-thia-1-azabicyclo[4.2.0]oct-2-ene-2-carboxylate monohydrochloride

[113359-04-9, Cefozopran]

Cefozopran Hydrochloride contains not less than 860 μg (potency) and not more than 960 μg (potency) per mg, calculated on the anhydrous basis. The potency of Cefozopran Hydrochloride is expressed as mass (potency) of cefozopran ($\text{C}_{19}\text{H}_{17}\text{N}_9\text{O}_5\text{S}_2$: 515.53).

Description Cefozopran Hydrochloride occurs as white to pale yellow, crystals or crystalline powder.

It is freely soluble in dimethylsulfoxide and in formamide, slightly soluble in water, in methanol and in ethanol (95), and practically insoluble in acetonitrile and diethylether.

Identification (1) Dissolve 0.02 g of Cefozopran Hydrochloride in 10 mL of water, add 1 mL of a solution of hydroxylammonium chloride (1 in 10) and 2 mL of sodium hydroxide TS, allow to stand for 5 minutes, then add 3 mL of 1 mol/L hydrochloric acid TS and 3 drops of iron (III) chloride TS, and mix: a red-purple color develops.

(2) Determine the absorption spectra of solutions of Cefozopran Hydrochloride and Cefozopran Hydrochloride RS in a mixture of sodium chloride TS and methanol (3:2) (1 in 100,000) as directed under Ultraviolet-visible Spectrophotometry <2.24>, and compare these spectra: both spectra exhibit similar intensities of absorption at the same wavelengths.

(3) Determine the ^1H spectrum of a solution of Cefozopran Hydrochloride in deuterated dimethylsulfoxide for nuclear magnetic resonance spectroscopy (1 in 20) as directed under Nuclear Magnetic Resonance Spectroscopy <2.21>, using tetramethylsilane for nuclear magnetic resonance spectroscopy as an internal reference compound: it

exhibits a singlet signal A at around δ 3.9 ppm, a doublet signal B at around δ 5.2 ppm, and a quartet signal C at around δ 8.0 ppm, and the ratio of integrated intensity of each signal, A:B:C, is about 3:1:1.

(4) Dissolve 0.01 g of Cefozopran Hydrochloride in 1 mL of water and 2 mL of acetic acid (100), add 2 drops of silver nitrate TS, and mix: a white turbidity is formed.

Absorbance <2.24> $E_{1\text{cm}}^{1\%}$ (238 nm): 455 – 485 (50 mg calculated on the anhydrous basis, a mixture of sodium chloride TS and methanol (3:2), 5000 mL).

Optical rotation <2.49> $[\alpha]_D^{20}$: $-73 - -78^\circ$ (0.1 g calculated on the anhydrous basis, a mixture of sodium chloride TS and methanol (3:2), 10 mL, 100 mm).

Purity (1) Clarity and color of solution—Being specified separately when the drug is granted approval based on the Law.

(2) Heavy metals <1.07>—Proceed with 2.0 g of Cefozopran Hydrochloride according to Method 2, and perform the test. Prepare the control solution with 2.0 mL of Standard Lead Solution (not more than 10 ppm).

(3) Arsenic—Being specified separately when the drug is granted approval based on the Law.

(4) Related substances—Being specified separately when the drug is granted approval based on the Law.

Water <2.48> Not more than 2.5% (0.5 g, volumetric titration, direct titration. Use a mixture of formamide for water determination and methanol for water determination (2:1) instead of methanol for water determination).

Residue on ignition Being specified separately when the drug is granted approval based on the Law.

Bacterial endotoxins <4.01> Less than 0.05 EU/mg (potency).

Assay Weigh accurately an amount of Cefozopran Hydrochloride and Cefozopran Hydrochloride RS, equivalent to about 50 mg (potency), and dissolve each in the mobile phase to make exactly 50 mL. Pipet 10 mL each of these solutions, add exactly 10 mL of the internal standard solution and the mobile phase to make 25 mL, and use these solutions as the sample solution and the standard solution, respectively. Perform the test with 10 μL each of the sample solution and standard solution as directed under Liquid Chromatography <2.01> according to the following conditions, and calculate the ratios, Q_T and Q_S , of the peak area of cefozopran to that of the internal standard.

$$\text{Amount } [\mu\text{g (potency)}] \text{ of cefozopran (C}_{19}\text{H}_{17}\text{N}_9\text{O}_5\text{S}_2) \\ = M_S \times Q_T/Q_S \times 1000$$

M_S : Amount [mg (potency)] of Cefozopran Hydrochloride RS taken

Internal standard solution—A solution of 2,4-dihydroxybenzoic acid in the mobile phase (1 in 1250).

Operating conditions—

Detector: An ultraviolet absorption photometer (wavelength: 254 nm).

Column: A stainless steel column 4.6 mm in inside diameter and 15 cm in length, packed with octadecylsilanized silica gel for liquid chromatography (5 μm in particle diameter).

Column temperature: A constant temperature of about 25°C.

Mobile phase: Mix 0.366 g of diethylamine with water to make 1000 mL, and add 60 mL of acetonitrile and 5 mL of acetic acid (100).

Flow rate: Adjust so that the retention time of cefozopran

is about 9 minutes.

System suitability—

System performance: When the procedure is run with 10 μL of the standard solution under the above operating conditions, cefozopran and the internal standard are eluted in this order with the resolution between these peaks being not less than 10.

System repeatability: When the test is repeated 6 times with 10 μL of the standard solution under the above operating conditions, the relative standard deviation of the ratios of the peak area of cefozopran to that of the internal standard is not more than 1.0%.

Containers and storage Containers—Hermetic containers.

Storage—Light-resistant.

Cefozopran Hydrochloride for Injection

注射用セフォゾプラン塩酸塩

Cefozopran Hydrochloride for Injection is a preparation for injection which is dissolved before use.

It contains not less than 90.0% and not more than 115.0% of the labeled potency of cefozopran ($\text{C}_{19}\text{H}_{17}\text{N}_9\text{O}_5\text{S}_2$; 515.53).

Method of Preparation Prepare as directed under the Injections, with Cefozopran Hydrochloride.

Description Cefozopran Hydrochloride for Injection occurs as a white to light yellow, powder or masses.

Identification (1) Determine the absorption spectrum of a solution of Cefozopran Hydrochloride for Injection (1 in 100,000) as directed under Ultraviolet-visible Spectrophotometry <2.24>: it exhibits a maximum between 236 nm and 241 nm.

(2) To 50 mg of Cefozopran Hydrochloride for Injection add 0.8 mL of deuterated dimethylsulfoxide for nuclear magnetic resonance spectroscopy, and filter after shaking, and determine the ^1H spectrum of the filtrate as directed under Nuclear Magnetic Resonance Spectroscopy <2.21>, using tetramethylsilane for nuclear magnetic resonance spectroscopy as an internal reference compound: it exhibits a singlet signal A at around δ 3.9 ppm, a doublet signal B at around δ 5.0 ppm, and a quartet signal C at around δ 8.0 ppm. The ratio of the integrated intensity of each signal, A:B:C, is about 3:1:1.

pH <2.54> Dissolve an amount of Cefozopran Hydrochloride for Injection, equivalent to 0.5 g (potency) of Cefozopran Hydrochloride, in 5 mL of water: the pH of this solution is between 7.5 and 9.0.

Purity (1) Clarity and color of solution—Dissolve an amount of Cefozopran Hydrochloride for Injection, equivalent to 1 g (potency) of Cefozopran Hydrochloride, in 10 mL of water: the solution is clear and has no more color than Matching Fluid N.

(2) Related substances—Being specified separately when the drug is granted approval based on the Law.

Water <2.48> Not more than 2.5% (0.5 g, volumetric titration, direct titration. Use a mixture of formamide for water determination and methanol for water determination (2:1) instead of methanol for water determination).

Bacterial endotoxins <4.01> Less than 0.05 EU/mg (po-

tency).

Uniformity of dosage units <6.02> It meets the requirement of the Mass variation test.

Foreign insoluble matter <6.06> It meets the requirement.

Insoluble particulate matter <6.07> It meets the requirement.

Sterility <4.06> Perform the test according to the Membrane filtration method: it meets the requirement.

Assay Weigh accurately the mass of the contents of not less than 10 Cefozopran Hydrochloride for Injection. Weigh accurately an amount of the contents, equivalent to about 0.5 g (potency) of Cefozopran Hydrochloride, and add water to make exactly 100 mL. Pipet 2 mL of this solution, add exactly 10 mL of the internal standard solution, add the mobile phase to make 25 mL, and use this solution as the sample solution. Separately, weigh accurately an amount of Cefozopran Hydrochloride RS, equivalent to about 50 mg (potency), and dissolve in the mobile phase to make exactly 50 mL. Pipet 10 mL of this solution, add exactly 10 mL of the internal standard solution, add the mobile phase to make 25 mL, and use this solution as the standard solution. Proceed as directed in the Assay under Cefozopran Hydrochloride.

$$\begin{aligned} &\text{Amount [mg (potency)] of cefozopran } (\text{C}_{19}\text{H}_{17}\text{N}_9\text{O}_5\text{S}_2) \\ &= M_S \times Q_T/Q_S \times 10 \end{aligned}$$

M_S : Amount [mg (potency)] of Cefozopran Hydrochloride RS taken

Internal standard solution—A solution 2,4-dihydroxybenzoic acid in the mobile phase (1 in 1250).

Containers and storage Containers—Hermetic containers. Plastic containers for aqueous injections may be used.

Storage—Light-resistant.

Cefpiramide Sodium

セフピラミドナトリウム

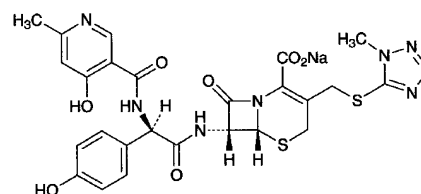

$\text{C}_{25}\text{H}_{23}\text{N}_8\text{NaO}_7\text{S}_2$; 634.62

Monosodium (6R,7R)-7-[(2R)-2-[(4-hydroxy-6-methylpyridine-3-carbonyl)amino]-2-(4-hydroxyphenyl)acetyl]amino]-3-(1-methyl-1H-tetrazol-5-ylsulfanylmethyl)-8-oxo-5-thia-1-azabicyclo[4.2.0]oct-2-ene-2-carboxylate
[74849-93-7]

Cefpiramide Sodium contains not less than 900 μg (potency) and not more than 990 μg (potency) per mg, calculated on the anhydrous basis. The potency of Cefpiramide Sodium is expressed as mass (potency) of cefpiramide ($\text{C}_{25}\text{H}_{24}\text{N}_8\text{O}_7\text{S}_2$; 612.64).

Description Cefpiramide Sodium occurs as white to yellowish white powder.

It is very soluble in dimethylsulfoxide, freely soluble in water, sparingly soluble in methanol, and slightly soluble in

ethanol (95).

Identification (1) Determine the absorption spectrum of a solution of Cefpiramide Sodium in 0.05 mol/L phosphate buffer solution (pH 7.0) (1 in 50,000) as directed under Ultraviolet-visible Spectrophotometry <2.24>, and compare the spectrum with the Reference Spectrum: both spectra exhibit similar intensities of absorption at the same wavelengths.

(2) Determine the ^1H spectrum of a solution of Cefpiramide Sodium in deuterated dimethylsulfoxide for nuclear magnetic resonance spectroscopy (1 in 10) as directed under Nuclear Magnetic Resonance Spectroscopy <2.21>, using tetramethylsilane for nuclear magnetic resonance spectroscopy as an internal reference compound: it exhibits singlet signals, A, B and C, at around δ 2.3 ppm, at around δ 3.9 ppm and at around δ 8.2 ppm, respectively. The ratio of the integrated intensity of each signal, A:B:C, is about 3:3:1.

(3) Cefpiramide Sodium responds to the Qualitative Tests <1.09> (1) for sodium salt.

Optical rotation <2.49> $[\alpha]_{\text{D}}^{20}$: $-33 - -40^\circ$ (0.2 g calculated on the anhydrous basis, 0.05 mol/L phosphate buffer solution (pH 7.0), 10 mL, 100 mm).

pH <2.54> The pH of a solution obtained by dissolving 2.0 g of Cefpiramide Sodium in 20 mL of water is between 5.5 and 8.0.

Purity (1) Clarity and color of solution—Dissolve 1.0 g of Cefpiramide Sodium in 10 mL of 0.05 mol/L phosphate buffer solution (pH 7.0): the solution is clear, and colorless or light yellow.

(2) Heavy metals <1.07>—Proceed with 1.0 g of Cefpiramide Sodium according to Method 2, and perform the test. Prepare the control solution with 2.0 mL of Standard Lead Solution (not more than 20 ppm).

(3) Related substances—Weigh accurately about 25 mg of Cefpiramide Sodium, dissolve in 0.03 mol/L phosphate buffer solution (pH 7.5) to make exactly 50 mL, and use this solution as the sample solution. Separately, weigh accurately about 25 mg of 1-methyl-1*H*-tetrazole-5-thiol for liquid chromatography, previously dried in a desiccator (in vacuum, silica gel) for 2 hours, and an amount of Cefpiramide RS, equivalent to about 75 mg (potency), dissolve them in 0.03 mol/L phosphate buffer solution (pH 7.5) to make exactly 100 mL. Pipet 2 mL of this solution, add 0.03 mol/L phosphate buffer solution (pH 7.5) to make exactly 100 mL, and use this solution as the standard solution. Perform the test with exactly 5 μL of the sample solution and standard solution as directed under Liquid Chromatography <2.01> according to the following conditions, and determine each peak area by the automatic integration method. Calculate the amount of 1-methyl-1*H*-tetrazole-5-thiol, each of the other related substances and the total of the other related substances by the following equations: the amount of 1-methyl-1*H*-tetrazole-5-thiol, each of the other related substances and the total of the other related substances are not more than 1.0%, not more than 1.5% and not more than 4.0%, respectively.

$$\begin{aligned} \text{Amount (\%)} \text{ of 1-methyl-1}H\text{-tetrazole-5-thiol (C}_2\text{H}_4\text{N}_4\text{S)} \\ = M_{\text{Sa}}/M_{\text{T}} \times A_{\text{Ta}}/A_{\text{Sa}} \end{aligned}$$

$$\begin{aligned} \text{Amount (\%)} \text{ of each of other related substances} \\ = M_{\text{Sb}}/M_{\text{T}} \times A_{\text{Tc}}/A_{\text{Sb}} \end{aligned}$$

M_{Sa} : Amount (mg) of 1-methyl-1*H*-tetrazole-5-thiol taken

M_{Sb} : Amount [mg (potency)] of Cefpiramide RS taken

M_{T} : Amount (mg) of Cefpiramide Sodium taken

A_{Sa} : Peak area of 1-methyl-1*H*-tetrazole-5-thiol from the standard solution

A_{Sb} : Peak area of cefpiramide from the standard solution

A_{Ta} : Peak area of 1-methyl-1*H*-tetrazole-5-thiol from the sample solution

A_{Tc} : Area of each peak other than 1-methyl-1*H*-tetrazole-5-thiol and cefpiramide from the sample solution

Operating conditions—

Detector: An ultraviolet absorption photometer (wavelength: 254 nm).

Column: A stainless steel column 4 mm in inside diameter and 30 cm in length, packed with octylsilanized silica gel for liquid chromatography (10 μm in particle diameter).

Column temperature: A constant temperature of about 25°C.

Mobile phase: A mixture of 0.03 mol/L phosphate buffer solution (pH 7.5) and methanol (3:1).

Flow rate: Adjust so that the retention time of cefpiramide is about 11 minutes.

Time span of measurement: About 2 times as long as the retention time of cefpiramide.

System suitability—

Test for required detectability: Measure exactly 5 mL of the standard solution, and add 0.03 mol/L phosphate buffer solution (pH 7.5) to make exactly 50 mL. Confirm that the peak area of 1-methyl-1*H*-tetrazole-5-thiol obtained with 5 μL of this solution is equivalent to 8 to 12% of that with 5 μL of the standard solution.

System performance: Dissolve 25 mg of Cefpiramide RS and 7 mg of cinnamic acid in the mobile phase to make 50 mL. When the procedure is run with 5 μL of this solution under the above operating conditions, cinnamic acid and cefpiramide are eluted in this order with the resolution between these peaks being not less than 3.

System repeatability: When the test is repeated 6 times with 5 μL of the standard solution under the above operating conditions, the relative standard deviation of the peak area of 1-methyl-1*H*-tetrazole-5-thiol is not more than 2.0%.

Water <2.48> Not more than 7.0% (0.35 g, volumetric titration, direct titration).

Assay Weigh accurately an amount of Cefpiramide Sodium and Cefpiramide RS, equivalent to about 50 mg (potency), add exactly 5 mL of the internal standard solution to dissolve, then add the mobile phase to make 100 mL, and use these solutions as the sample solution and standard solution. Perform the test with 5 μL each of the sample solution and standard solution as directed under Liquid Chromatography <2.01> according to the following conditions, and calculate the ratios, Q_{T} and Q_{S} , of the peak area of cefpiramide to that of the internal standard.

$$\begin{aligned} \text{Amount } [\mu\text{g (potency)}] \text{ of cefpiramide (C}_{25}\text{H}_{24}\text{N}_8\text{O}_7\text{S}_2) \\ = M_{\text{S}} \times Q_{\text{T}}/Q_{\text{S}} \times 1000 \end{aligned}$$

M_{S} : Amount [mg (potency)] of Cefpiramide RS taken

Internal standard solution—A solution of 4-dimethylaminoantipyrine (1 in 100).

Operating conditions—

Detector: An ultraviolet absorption photometer (wavelength: 254 nm).

Column: A stainless steel column 4 mm in inside diameter and 30 cm in length, packed with octylsilanized silica gel for liquid chromatography (10 μm in particle diameter).

Column temperature: A constant temperature of about 25°C.

Mobile phase: A mixture of 0.01 mol/L phosphate buffer

solution (pH 6.8), acetonitrile, methanol and tetrahydrofuran (22:1:1:1).

Flow rate: Adjust so that the retention time of cefpiramide is about 7 minutes.

System suitability—

System performance: When the procedure is run with 5 μ L of the standard solution under the above operating conditions, cefpiramide and the internal standard are eluted in this order with the resolution between these peaks being not less than 7.

System repeatability: When the test is repeated 6 times with 5 μ L of the standard solution under the above operating conditions, the relative standard deviation of the ratio of the peak area of cefpiramide to that of the internal standard is not more than 2.0%.

Containers and storage Containers—Tight containers.

Storage—Light-resistant, and at a temperature not exceeding 5°C.

Cefpirome Sulfate

セフピロム硫酸塩

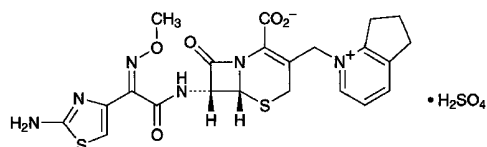

$C_{22}H_{22}N_6O_5S_2 \cdot H_2SO_4$; 612.66

(6*R*,7*R*)-7-[(*Z*)-2-(2-Aminothiazol-4-yl)-2-(methoxyimino)acetylamino]-3-(6,7-dihydro-5*H*-cyclopenta[*b*]pyridinium-1-ylmethyl)-8-oxo-5-thia-1-azabicyclo[4.2.0]oct-2-ene-2-carboxylate monosulfate [98753-19-6]

Cefpirome Sulfate contains not less than 760 μ g (potency) per mg, calculated on the anhydrous basis. The potency of Cefpirome Sulfate is expressed as mass (potency) of cefpirome ($C_{22}H_{22}N_6O_5S_2$; 514.58).

Description Cefpirome Sulfate occurs as a white to pale yellow-white crystalline powder, and has a slight, characteristic odor.

It is soluble in water, and practically insoluble in ethanol (95) and in diethyl ether.

It is hygroscopic.

Identification (1) Dissolve 10 mg of Cefpirome Sulfate in 2 mL of water, add 3 mL of hydroxylammonium hydrochloride-ethanol TS, allow to stand for 5 minutes, add 1 mL of acidic ammonium iron (III) sulfate TS, and shake: a red-brown color develops.

(2) Dissolve 1 mg of Cefpirome Sulfate in 4 mL of water, add 1 mL of dilute hydrochloric acid while cooling in ice, add 1 mL of a freshly prepared solution of sodium nitrite (1 in 100), and allow to stand for 2 minutes. Add 1 mL of ammonium amidosulfuric acid TS while cooling in ice bath, allow to stand for 1 minute, and add 1 mL of a solution of *N*-1-naphthylethylene dihydrochloride (1 in 1000): a purple color develops.

(3) Take 5 mg of Cefpirome Sulfate, dissolve in 1 mL of ethanol (95) and 1 mL of water, add 100 mg of 1-chloro-2,4-dinitrobenzene, and heat on a water bath for 5 minutes. After cooling, add 2 or 3 drops of a solution of sodium hydroxide (1 in 10) and 3 mL of ethanol (95): a red-brown color develops.

(4) Determine the absorption spectra of solutions of Cefpirome Sulfate and Cefpirome Sulfate RS in 0.01 mol/L hydrochloric acid TS (1 in 50,000) as directed under Ultraviolet-visible Spectrophotometry <2.24>, and compare the spectra: both spectra exhibit similar intensities of absorption at the same wavelengths.

(5) Determine the 1H spectrum of a solution of Cefpirome Sulfate in heavy water for nuclear magnetic resonance spectroscopy (1 in 25) as directed under Nuclear Magnetic Resonance Spectroscopy <2.21>, using sodium 3-trimethylsilylpropanesulfonate for nuclear magnetic resonance spectroscopy as an internal reference compound: it exhibits a singlet signal A at around δ 4.1 ppm, a doublet signal B at around δ 5.9 ppm, a singlet signal C at around δ 7.1 ppm, and a multiplet signal D at around δ 7.8 ppm. The ratio of integrated intensity of each signal, A:B:C:D, is about 3:1:1:1.

(6) A solution of Cefpirome Sulfate (1 in 250) responds to Qualitative Tests <1.09> (1) for sulfate salt.

Absorbance <2.24> $E_{1\text{ cm}}^{1\%}$ (270 nm): 405 – 435 (50 mg calculated on the anhydrous basis, 0.01 mol/L hydrochloric acid TS, 2500 mL).

Optical rotation <2.49> $[\alpha]_D^{20}$: –27 – –33° (50 mg calculated on the anhydrous basis, a solution prepared by addition of water to 25 mL of acetonitrile to make 50 mL, 20 mL, 100 mm).

pH <2.54> Dissolve 0.1 g of Cefpirome Sulfate in 10 mL of water: the pH of the solution is between 1.6 and 2.6.

Purity (1) Clarity and color of solution—Being specified separately when the drug is granted approval based on the Law.

(2) Heavy metals <1.07>—Proceed with 1.0 g of Cefpirome Sulfate according to Method 2, and perform the test. Prepare the control solution with 2.0 mL of Standard Lead Solution (not more than 20 ppm).

(3) Arsenic—Being specified separately when the drug is granted approval based on the Law.

(4) Related substances—Being specified separately when the drug is granted approval based on the Law.

Water <2.48> Not more than 2.5% (0.5 g, volumetric titration, direct titration).

Residue on ignition Being specified separately when the drug is granted approval based on the Law.

Bacterial endotoxins <4.01> Less than 0.10 EU/mg (potency).

Assay Weigh accurately an amount of Cefpirome Sulfate and Cefpirome Sulfate RS, equivalent to about 50 mg (potency), dissolve each in water to make exactly 100 mL. Pipet 5 mL of these solutions, add each in water to make exactly 20 mL, and use these solutions as the sample solution and standard solution. Perform the test with exactly 20 μ L of the sample solution and standard solution as directed under Liquid Chromatography <2.01> according to the following conditions, and determine the peak areas, A_T and A_S , of cefpirome in each solution.

$$\text{Amount } [\mu\text{g (potency)}] \text{ of cefpirome } (C_{22}H_{22}N_6O_5S_2) \\ = M_S \times A_T / A_S \times 1000$$

M_S : Amount [mg (potency)] of Cefpirome Sulfate RS taken

Operating conditions—

Detector: An ultraviolet absorption photometer (wavelength: 270 nm).

Column: A stainless steel column 4.6 mm in inside diameter and 25 cm in length, packed with octadecylsilanized silica gel for liquid chromatography (5 μ m in particle diameter).

Column temperature: A constant temperature of about 25°C.

Mobile phase: Dissolve 3.45 g of ammonium dihydrogenphosphate in 1000 mL of water, and adjust the pH to 3.3 with phosphoric acid. To 800 mL of this solution add 100 mL of acetonitrile.

Flow rate: Adjust so that the retention time of cefpirome is about 7.5 minutes.

System suitability—

System performance: When the procedure is run with 20 μ L of the standard solution under the above operating conditions, the number of theoretical plates of the peak of cefpirome is not less than 3600.

System repeatability: When the test is repeated 5 times with 20 μ L of the standard solution under the above operating conditions, the relative standard deviation of the peak areas of cefpirome is not more than 1.0%.

Containers and storage Containers—Hermetic containers.

Storage—At a temperature between 2°C and 8°C.

Cefpodoxime Proxetil

セフポドキシム プロキシセチル

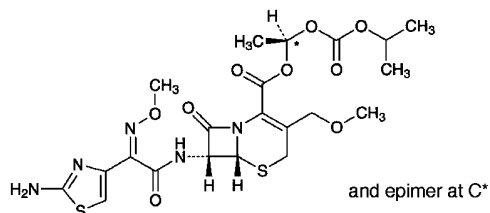

$C_{21}H_{27}N_5O_9S_2$; 557.60

(1*RS*)-1-[(1-Methylethoxy)carbonyloxy]ethyl
(6*R*,7*R*)-7-[(*Z*)-2-(2-aminothiazol-4-yl)-2-(methoxyimino)acetylamino]-3-methoxymethyl-8-oxo-5-thia-1-azabicyclo[4.2.0]oct-2-ene-2-carboxylate
[87239-81-4]

Cefpodoxime Proxetil contains not less than 706 μ g (potency) and not more than 774 μ g (potency) per mg, calculated on the anhydrous basis. The potency of Cefpodoxime Proxetil is expressed as mass (potency) of cefpodoxime ($C_{15}H_{17}N_5O_6S_2$; 427.46).

Description Cefpodoxime Proxetil occurs as a white to light brown-white powder.

It is very soluble in acetonitrile, in methanol and in chloroform, freely soluble in ethanol (99.5), and very slightly soluble in water.

Identification (1) Determine the absorption spectrum of a solution of Cefpodoxime Proxetil in acetonitrile (3 in 200,000) as directed under Ultraviolet-visible Spectrophotometry <2.24>, and compare the spectrum with the Reference Spectrum or the spectrum of a solution of Cefpodoxime Proxetil RS prepared in the same manner as the sample solution: both spectra exhibit similar intensities of absorption at the same wavelengths.

(2) Determine the infrared absorption spectrum of Cef-

podoxime Proxetil as directed in the potassium bromide disk method under Infrared Spectrophotometry <2.25>, and compare the spectrum with the Reference Spectrum or the spectrum of Cefpodoxime Proxetil RS: both spectra exhibit similar intensities of absorption at the same wave numbers.

(3) Determine the 1H spectrum of a solution of Cefpodoxime Proxetil in deuteriochloroform for nuclear magnetic resonance spectroscopy (1 in 10) as directed under Nuclear Magnetic Resonance Spectroscopy <2.21>, using tetramethylsilane for nuclear magnetic resonance spectroscopy as an internal reference compound: it exhibits doublet signals, A and B, at around δ 1.3 ppm and at around δ 1.6 ppm, and singlet signals, C and D, at around δ 3.3 ppm and at around δ 4.0 ppm. The ratio of the integrated intensity of these signals, A:B:C:D, is about 2:1:1:1.

Optical rotation <2.49> $[\alpha]_D^{20}$: +24.0 – +31.4° (0.1 g calculated on the anhydrous basis, acetonitrile, 20 mL, 100 mm).

Purity (1) Heavy metals <1.07>—Proceed with 1.0 g of Cefpodoxime Proxetil according to Method 2, and perform the test. Prepare the control solution with 2.0 mL of Standard Lead Solution (not more than 20 ppm).

(2) Related substances—Dissolve 50 mg of Cefpodoxime Proxetil in 50 mL of a mixture of water, acetonitrile and acetic acid (100) (99:99:2), and use this solution as the sample solution. Perform the test with 20 μ L of the sample solution as directed under Liquid Chromatography <2.01> according to the following conditions. Determine each peak area by the automatic integration method, and calculate the amounts of them by the area percentage method: the amount of the peak, having the relative retention time of about 0.8 to the isomer B of cefpodoxime proxetil, is not more than 2.0%, the amount of the peak other than cefpodoxime proxetil is not more than 1.0%, and the total amount of the peaks other than cefpodoxime proxetil is not more than 6.0%.

Operating conditions—

Detector: An ultraviolet absorption photometer (wavelength: 254 nm).

Column: A stainless steel column 4.6 mm in inside diameter and 15 cm in length, packed with octadecylsilanized silica gel for liquid chromatography (5 μ m in particle diameter).

Column temperature: A constant temperature of about 22°C.

Mobile phase A: A mixture of water, methanol and a solution of formic acid (1 in 50) (11:8:1).

Mobile phase B: A mixture of methanol and a solution of formic acid (1 in 50) (19:1).

Flowing of mobile phase: Control the gradient by mixing the mobile phases A and B as directed in the following table.

Time after injection of sample (min)	Mobile phase A (vol%)	Mobile phase B (vol%)
0 – 65	95	5
65 – 145	95 → 15	5 → 85
145 – 155	15	85

Flow rate: 0.7 mL per minute (the retention time of the isomer B of cefpodoxime proxetil is about 60 minutes).

Time span of measurement: For 155 minutes after injection, beginning after the solvent peak.

System suitability—

Test for required detectability: To 5 mL of the sample solution add a mixture of water, acetonitrile and acetic acid (100) (99:99:2) to make 200 mL, and use this solution as the

solution for system suitability test. Pipet 2 mL of the solution for system suitability test, and add the mixture of water, acetonitrile and acetic acid (100) (99:99:2) to make exactly 100 mL. Confirm that the peak areas of the isomer A and the isomer B of cefpodoxime proxetil obtained with 20 μ L of this solution are equivalent to 1.4 to 2.6% of them with 20 μ L of the solution for system suitability test, respectively.

System performance: When the procedure is run with 20 μ L of the solution for system suitability test under the above operating conditions, the isomer A and the isomer B of cefpodoxime proxetil are eluted in this order with the resolution between these peaks being not less than 6.

System repeatability: When the test is repeated 5 times with 20 μ L of the solution for system suitability test under the above operating conditions, the relative standard deviation of the peak area of the isomer A and the isomer B of cefpodoxime proxetil is not more than 2.0%.

Water <2.48> Not more than 2.5% (0.5 g, volumetric titration, direct titration).

Residue on ignition <2.44> Not more than 0.2% (1 g).

Isomer ratio Perform the test with 5 μ L of the sample solution obtained in the Assay as directed under Liquid Chromatography <2.01> according to the following conditions, and determine the peak areas of the two isomers of cefpodoxime proxetil, A_a , for the isomer having the smaller retention time, and A_b , for the isomer having the larger retention time, by the automatic integration method: $A_b/(A_a + A_b)$ is between 0.50 and 0.60.

Operating conditions—

Proceed as directed in the operating conditions in the Assay.

System suitability—

System performance: When the procedure is run with 5 μ L of the standard solution obtained in the Assay under the above operating conditions, the internal standard, the isomer A and the isomer B of cefpodoxime proxetil are eluted in this order with the resolution between the peaks of the isomers being not less than 4.

System repeatability: When the test is repeated 5 times with 5 μ L of the standard solution obtained in the Assay under the above operating conditions, the relative standard deviation of the ratio of the peak area of the isomer B of cefpodoxime proxetil to that of the internal standard is not more than 1.0%.

Assay Weigh accurately an amount of Cefpodoxime Proxetil and Cefpodoxime Proxetil RS, equivalent to about 60 mg (potency), dissolve in 80 mL of acetonitrile, add exactly 4 mL of the internal standard solution, add acetonitrile to make 100 mL, and use these solutions as the sample solution and standard solution. Perform the test with 5 μ L each of the sample solution and standard solution as directed under Liquid Chromatography <2.01> according to the following conditions, and calculate the ratios, Q_{T1} , Q_{S1} , Q_{T2} and Q_{S2} , of the areas of the two peaks of the isomers of cefpodoxime proxetil to the peak area of the internal standard.

$$\begin{aligned} \text{Amount } [\mu\text{g (potency)}] \text{ of cefpodoxime (C}_{15}\text{H}_{17}\text{N}_5\text{O}_6\text{S}_2) \\ = M_S \times (Q_{T1} + Q_{T2}) / (Q_{S1} + Q_{S2}) \times 1000 \end{aligned}$$

M_S : Amount [mg (potency)] of Cefpodoxime Proxetil RS taken

Internal standard solution—Dissolve 0.3 g of ethyl parahydroxybenzoate in a solution of citric acid in acetonitrile (1 in 2000) to make 100 mL.

Operating conditions—

Detector: An ultraviolet absorption photometer (wavelength: 240 nm).

Column: A stainless steel column 4.6 mm in inside diameter and 15 cm in length, packed with octadecylsilanized silica gel for liquid chromatography (5 μ m in particle diameter).

Column temperature: A constant temperature of about 40°C.

Mobile phase: A mixture of water and methanol (11:9).

Flow rate: Adjust so that the retention time of the internal standard is about 11 minutes.

System suitability—

System performance: When the procedure is run with 5 μ L of the standard solution under the above operating conditions, the internal standard, the isomer A and the isomer B are eluted in this order with the resolution between these peaks being not less than 4.

System repeatability: When the test is repeated 5 times with 5 μ L of the standard solution under the above operating conditions, the relative standard deviation of the ratios of the peak area of the isomer B of cefpodoxime proxetil to that of the internal standard is not more than 1.0%.

Containers and storage Containers—Tight containers.

Cefpodoxime Proxetil for Syrup

シロップ用セフポドキシム プロキシセチル

Cefpodoxime Proxetil for Syrup is a preparation for syrups which is suspended before use.

It contains not less than 93.0% and not more than 107.0% of the labeled potency of cefpodoxime (C₁₅H₁₇N₅O₆S₂: 427.46).

Method of preparation Prepare as directed under Syrups, with Cefpodoxime Proxetil.

Identification To an amount of Cefpodoxime Proxetil for Syrup, equivalent to 15 mg (potency) of Cefpodoxime Proxetil, add 10 mL of 0.1 mol/L phosphate buffer solution (pH 8.0), treat with ultrasonic waves for 5 minutes while occasional shaking. Then, add 20 mL of ethyl acetate, shake for 5 minutes, and centrifuge. Take 3 mL of the supernatant liquid, evaporate the ethyl acetate by warming at 40°C under reduced pressure. Dissolve the residue in acetonitrile to make 200 mL, and determine the absorption spectrum of this solution as directed under Ultraviolet-visible Spectrophotometry <2.24>: it exhibits a maximum between 232 nm and 236 nm.

Uniformity of dosage units <6.02> Perform the test according to the following method: Cefpodoxime Proxetil for Syrup in single-dose packages meet the requirement of the Content uniformity test.

To the total content of 1 package of Cefpodoxime Proxetil for Syrup add exactly 30 mL of the internal standard solution, treat with ultrasonic waves for 10 minutes while occasional shaking, and centrifuge. Take 3 mL of the supernatant liquid, add a mixture of water, acetonitrile and acetic acid (100) (99:99:2) to make 20 mL, and use this solution as the sample solution. Separately, weigh accurately an amount of Cefpodoxime Proxetil RS, equivalent to about 50 mg (potency), dissolve in a suitable amount of a mixture of water, acetonitrile and acetic acid (100) (99:99:2), add exactly 15 mL of the internal standard solution, then add a mixture of water, acetonitrile and acetic acid (100) (99:99:2) to make 100 mL, and use this solution as the standard solution.

Then, proceed as directed in the Assay under Cefpodoxime Proxetil.

$$\text{Amount [mg (potency)] of cefpodoxime (C}_{15}\text{H}_{17}\text{N}_5\text{O}_6\text{S}_2) \\ = M_S \times (Q_{T1} + Q_{T2}) / (Q_{S1} + Q_{S2}) \times 2$$

M_S : Amount [mg (potency)] of Cefpodoxime Proxetil RS taken

Internal standard solution—Dissolve 0.2 g of ethyl parahydroxybenzoate in a mixture of water, acetonitrile and acetic acid (100) (99:99:2) to make 300 mL.

Dissolution <6.10> When the test is performed at 50 revolutions per minute according to the Paddle method, using 900 mL of water as the dissolution medium, the dissolution rates in 15 minutes of Cefpodoxime Proxetil for Syrup is not less than 85%.

Start the test with an accurately weighed amount of Cefpodoxime Proxetil for Syrup, equivalent to about 50 mg (potency) of Cefpodoxime Proxetil, withdraw not less than 20 mL of the medium at the specified minute after starting the test, and filter through a membrane filter with a pore size not exceeding 0.5 μm . Discard not less than 10 mL of the first filtrate, pipet 5 mL of the subsequent filtrate, add a solution of citric acid monohydrate in the mobile phase (1 in 2000) to make exactly 25 mL, and use this solution as the sample solution. Separately, weigh accurately an amount of Cefpodoxime Proxetil RS, equivalent to about 22 mg (potency), dissolve in a solution of citric acid monohydrate in the mobile phase (1 in 2000) to make exactly 100 mL. Pipet 5 mL of this solution, add a solution of citric acid monohydrate in the mobile phase (1 in 2000) to make exactly 100 mL, and use this solution as the standard solution. Perform the test with exactly 10 μL each of the sample solution and standard solution as directed under Liquid Chromatography <2.01> according to the following conditions, and determine the areas, A_{Ta} and A_{Sa} , of the one peak which appears at the retention time of about 24 minutes among the two peaks obtainable from cefpodoxime proxetil, and the areas, A_{Tb} and A_{Sb} , of the peak which appears at the retention time of about 30 minutes, in each solution.

$$\text{Dissolution rate (\%)} \text{ with respect to the labeled amount} \\ \text{of cefpodoxime proxetil (C}_{21}\text{H}_{27}\text{N}_5\text{O}_9\text{S}_2) \\ = M_S / M_T \times (A_{Ta} + A_{Tb}) / (A_{Sa} + A_{Sb}) \times 1 / C \times 225$$

M_S : Amount [mg (potency)] of Cefpodoxime Proxetil RS taken

M_T : Amount (g) of Cefpodoxime Proxetil for Syrup taken
C: Labeled amount [mg (potency)] of cefpodoxime proxetil (C₂₁H₂₇N₅O₉S₂) in 1 g

Operating conditions—

Detector, column, column temperature, and mobile phase: Proceed as directed in the operating conditions in the Assay under Cefpodoxime Proxetil.

Flow rate: Adjust so that the retention time of the peak, which elutes faster among the two peaks obtained from cefpodoxime proxetil, is about 24 minutes.

System suitability—

System performance: When the procedure is run with 10 μL of the standard solution under the above operating conditions, the resolution between the two peaks obtained from cefpodoxime proxetil is not less than 4.

System repeatability: When the test is repeated 6 times with 10 μL of the standard solution under the above operating conditions, the relative standard deviation of the sum of the areas of the two peaks obtained from cefpodoxime proxetil is not more than 2.0%.

Assay Weigh accurately an amount of powdered Cefpodoxime Proxetil for Syrup, equivalent to about 0.1 g (potency) of Cefpodoxime Proxetil, add exactly 30 mL of the internal standard solution, treat with ultrasonic waves for 10 minutes while occasional shaking, and centrifuge. Take 3 mL of the supernatant liquid, add a mixture of water, acetonitrile and acetic acid (100) (99:99:2) to make 20 mL, and use this solution as the sample solution. Separately, weigh accurately an amount of Cefpodoxime Proxetil RS, equivalent to about 50 mg (potency), dissolve in a suitable amount of a mixture of water, acetonitrile and acetic acid (100) (99:99:2), add exactly 15 mL of the internal standard solution, then add a mixture of water, acetonitrile and acetic acid (100) (99:99:2) to make 100 mL, and use this solution as the standard solution. Then, proceed as directed in the Assay under Cefpodoxime Proxetil.

$$\text{Amount [mg (potency)] of cefpodoxime (C}_{15}\text{H}_{17}\text{N}_5\text{O}_6\text{S}_2) \\ = M_S \times (Q_{T1} + Q_{T2}) / (Q_{S1} + Q_{S2}) \times 2$$

M_S : Amount [mg (potency)] of Cefpodoxime Proxetil RS taken

Internal standard solution—Dissolve 0.2 g of ethyl parahydroxybenzoate in a mixture of water, acetonitrile and acetic acid (100) (99:99:2) to make 300 mL.

Containers and storage Containers—Tight containers.

Cefpodoxime Proxetil Tablets

セフポドキシム プロキシセチル錠

Cefpodoxime Proxetil Tablets contain not less than 93.0% and not more than 107.0% of the labeled potency of cefpodoxime (C₁₅H₁₇N₅O₆S₂: 427.46).

Method of preparation Prepare as directed under Tablets, with Cefpodoxime Proxetil.

Identification Powder Cefpodoxime Proxetil Tablets. To a portion of the powder, equivalent to 65 mg (potency) of Cefpodoxime Proxetil, add 25 mL of acetonitrile, shake thoroughly, and centrifuge. To 2 mL of the supernatant liquid add acetonitrile to make 50 mL. To 5 mL of this solution add acetonitrile to make 50 mL. Determine the absorption spectrum of this solution as directed under Ultraviolet-visible Spectrophotometry <2.24>: it exhibits a maximum between 232 nm and 236 nm.

Uniformity of dosage units <6.02> Perform the Mass variation test, or the Content uniformity test according to the following method: it meets the requirement.

To 1 tablet of Cefpodoxime Proxetil Tablets, add exactly 20 mL of a mixture of water, acetonitrile and acetic acid (100) (99:99:2), agitate with the aid of ultrasonic waves for 10 minutes, and filter through a membrane filter with a pore size not exceeding 0.45 μm . Discard the first 10 mL of the filtrate, pipet V mL of the subsequent filtrate, equivalent to 30 mg (potency) of Cefpodoxime Proxetil, add exactly 6 mL of the internal standard solution, then add a mixture of water, acetonitrile and acetic acid (100) (99:99:2) to make 50 mL, and use this solution as the sample solution. Separately, weigh accurately an amount of Cefpodoxime Proxetil RS, equivalent to about 60 mg (potency), dissolve in 60 mL of a mixture of water, acetonitrile and acetic acid (100) (99:99:2), add exactly 12 mL of the internal standard solution, then add a mixture of water, acetonitrile and acetic acid (100) (99:99:2) to make 100 mL, and use this solution as the stand-

ard solution. Then, proceed as directed in the Assay under Cefpodoxime Proxetil.

$$\text{Amount [mg (potency)] of cefpodoxime (C}_{15}\text{H}_{17}\text{N}_5\text{O}_6\text{S}_2) \\ = M_S \times (Q_{T1} + Q_{T2}) / (Q_{S1} + Q_{S2}) \times 10 / V$$

M_S : Amount [mg (potency)] of Cefpodoxime Proxetil RS taken

Internal standard solution—Dissolve 0.1 g of ethyl parahydroxybenzoate in a mixture of water, acetonitrile and acetic acid (100) (99:99:2) to make 100 mL.

Dissolution <6.10> When the test is performed at 50 revolutions per minute according to the Paddle method, using 900 mL of water as the dissolution medium, the dissolution rate in 45 minutes of Cefpodoxime Proxetil Tablets is not less than 70%.

Start the test with 1 tablet of Cefpodoxime Proxetil Tablets, withdraw not less than 20 mL of the medium at the specified minute after starting the test, and filter through a membrane filter with a pore size not exceeding 0.5 μm . Discard not less than 10 mL of the first filtrate, pipet V mL of the subsequent filtrate, add a solution of citric acid monohydrate in the mobile phase (1 in 2000) to make exactly V' mL so that each mL contains about 11 μg (potency) of Cefpodoxime Proxetil, and use this solution as the sample solution. Separately, weigh accurately an amount of Cefpodoxime Proxetil RS, equivalent to about 22 mg (potency), and dissolve in a solution of citric acid monohydrate in the mobile phase (1 in 2000) to make exactly 100 mL. Pipet 5 mL of this solution, add a solution of citric acid monohydrate in the mobile phase (1 in 2000) to make exactly 100 mL, and use this solution as the standard solution. Perform the test with exactly 10 μL each of the sample solution and standard solution as directed under Liquid Chromatography <2.01> according to the following conditions, and determine the areas of separated two peaks, one has the retention time of about 24 minutes, A_{Ta} and A_{Sa} , and another one has the retention time of about 30 minutes, A_{Tb} and A_{Sb} , in each solution.

Dissolution rate (%) with respect to the labeled amount of cefpodoxime proxetil (C₂₁H₂₇N₅O₉S₂)

$$= M_S \times (A_{Ta} + A_{Tb}) / (A_{Sa} + A_{Sb}) \times V' / V \times 1 / C \times 45$$

M_S : Amount [mg (potency)] of Cefpodoxime Proxetil RS taken

C : Labeled amount [mg (potency)] of cefpodoxime proxetil (C₂₁H₂₇N₅O₉S₂) in 1 tablet

Operating conditions—

Detector: An ultraviolet absorption photometer (wavelength: 240 nm).

Column: A stainless steel column 4.6 mm in inside diameter and 15 cm in length, packed with octadecylsilanized silica gel for liquid chromatography (5 μm in particle diameter).

Column temperature: A constant temperature of about 40°C.

Mobile phase: A mixture of water and methanol (11:9).

Flow rate: Adjust so that the retention time of one of the two peaks that elutes first is about 24 minutes.

System suitability—

System performance: When the procedure is run with 10 μL of the standard solution under the above operating conditions, the resolution between the two peaks of cefpodoxime proxetil is not less than 4.

System repeatability: When the test is repeated 6 times with 10 μL of the standard solution under the above operating conditions, the relative standard deviation of the total

area of the two peaks of cefpodoxime proxetil is not more than 2.0%.

Assay Weigh accurately the mass of not less than 20 Cefpodoxime Proxetil Tablets, and powder. Weigh accurately a portion of the powder, equivalent to about 0.3 g (potency) of Cefpodoxime Proxetil, add 80 mL of a mixture of water, acetonitrile and acetic acid (100) (99:99:2), agitate for 10 minutes with the aid of ultrasonic waves, and add a mixture of water, acetonitrile and acetic acid (100) (99:99:2) to make exactly 100 mL. Filter this solution through a membrane filter with a pore size not exceeding 0.45 μm . Discard the first 10 mL of the filtrate, pipet 10 mL of the subsequent filtrate, add exactly 6 mL of the internal standard solution, then, add a mixture of water, acetonitrile and acetic acid (100) (99:99:2) to make 50 mL, and use this solution as the sample solution. Separately, weigh accurately an amount of Cefpodoxime Proxetil RS, equivalent to about 60 mg (potency), dissolve in 60 mL of a mixture of water, acetonitrile and acetic acid (100) (99:99:2), add exactly 12 mL of the internal standard solution, then add a mixture of water, acetonitrile and acetic acid (100) (99:99:2) to make 100 mL, and use this solution as the standard solution. Then, proceed as directed in the Assay under Cefpodoxime Proxetil.

$$\text{Amount [mg (potency)] of cefpodoxime (C}_{15}\text{H}_{17}\text{N}_5\text{O}_6\text{S}_2) \\ = M_S \times (Q_{T1} + Q_{T2}) / (Q_{S1} + Q_{S2}) \times 5$$

M_S : Amount [mg (potency)] of Cefpodoxime Proxetil RS taken

Internal standard solution—Dissolve 0.1 g of ethyl parahydroxybenzoate in a mixture of water, acetonitrile and acetic acid (100) (99:99:2) to make 100 mL.

Containers and storage Containers—Tight containers.

Cefroxadine Hydrate

セフロキサジン水和物

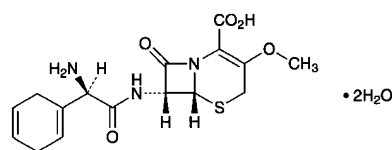

C₁₆H₁₉N₃O₅S·2H₂O: 401.43

(6*R*,7*R*)-7-[(2*R*)-2-Amino-2-cyclohexa-1,4-dienylacetyl-amino]-3-methoxy-8-oxo-5-thia-1-azabicyclo[4.2.0]oct-2-ene-2-carboxylic acid dihydrate [51762-05-1, anhydride]

Cefroxadine Hydrate contains not less than 930 μg (potency) and not more than 1020 μg (potency) per mg, calculated on the anhydrous basis. The potency of Cefroxadine Hydrate is expressed as mass (potency) of cefroxadine (C₁₆H₁₉N₃O₅S: 365.40).

Description Cefroxadine Hydrate occurs as pale yellow-white to light yellow, crystalline particles or powder.

It is very soluble in formic acid, slightly soluble in water and in methanol, and very slightly soluble in acetonitrile and in ethanol (95).

It dissolves in 0.001 mol/L hydrochloric acid TS and in dilute acetic acid.

Identification (1) Determine the absorption spectrum of a solution of Cefroxadine Hydrate in 0.001 mol/L hydrochloric acid TS (1 in 50,000) as directed under Ultraviolet-visible

Spectrophotometry <2.24>, and compare the spectrum with the Reference Spectrum or the spectrum of a solution of Cefroxadine RS prepared in the same manner as the sample solution: both spectra exhibit similar intensities of absorption at the same wavelengths.

(2) Determine the infrared absorption spectrum of Cefroxadine Hydrate as directed in the potassium bromide disk method under Infrared Spectrophotometry <2.25>, and compare the spectrum with the Reference Spectrum or the spectrum of Cefroxadine RS: both spectra exhibit similar intensities of absorption at the same wave numbers.

(3) Determine the ^1H spectrum of a solution of Cefroxadine Hydrate in deuterated formic acid for nuclear magnetic resonance spectroscopy (1 in 10) as directed under Nuclear Magnetic Resonance Spectroscopy <2.21>, using tetramethylsilane for nuclear magnetic resonance spectroscopy as an internal reference compound: it exhibits three sharp singlet signals, A, B and C, at around δ 2.8 ppm, at around δ 4.1 ppm and at around δ 6.3 ppm. The ratio of the integrated intensity of each signal, A:B:C, is about 4:3:1.

Optical rotation <2.49> $[\alpha]_D^{20}$: +95 – +108° (0.1 g calculated on the anhydrous basis, diluted acetic acid (100) (3 in 25), 100 mL, 100 mm).

Purity (1) Heavy metals <1.07>—Weigh 1.0 g of Cefroxadine Hydrate in a porcelain crucible, add 10 mL of a solution of magnesium nitrate hexahydrate in ethanol (95) (1 in 10), mix, burn the ethanol, and carbonize by gently heating. After cooling, add 2 mL of nitric acid, heat carefully, and incinerate by ignition at 500 – 600°C. If a carbonized substance still remains, moisten it with a small amount of nitric acid, and incinerate again by ignition. After cooling, add 6 mL of hydrochloric acid, and evaporate on a water bath to dryness. Moisten the residue with 3 drops of hydrochloric acid, and add 10 mL of hot water to dissolve the residue by heating on a water bath. After cooling, adjust the pH between 3 and 4 with ammonia TS, add 2 mL of dilute acetic acid, filter if necessary, transfer to a Nessler tube, wash the crucible with 10 mL of water, and add the washing and water to the tube to make 50 mL. Perform the test with this solution. Prepare the control solution as follows: Put 2.0 mL of Standard Lead Solution and 10 mL of a solution of magnesium nitrate hexahydrate in ethanol (95) (1 in 10) in a porcelain crucible, and proceed as directed for the preparation of the test solution (not more than 20 ppm).

(2) Related substances—Dissolve 10 mg of Cefroxadine Hydrate in 100 mL of the mobile phase, and use this solution as the sample solution. Pipet 1 mL of the sample solution, add the mobile phase to make exactly 100 mL, and use this solution as the standard solution. Perform the test with exactly 40 μL each of the sample solution and standard solution as directed under Liquid Chromatography <2.01> according to the following conditions, and determine each peak area by the automatic integration method: the areas of the peaks, having the relative retention times of about 0.07, about 0.6 and about 0.8 to cefroxadine obtained from the sample solution are not larger than 2 times, 4 times and 1 time the peak area of cefroxadine from the standard solution, respectively, and any peak area other than cefroxadine and other than the peaks mentioned above is not larger than 1/2 times the peak area of cefroxadine from the standard solution, and the total area of the peaks other than cefroxadine is not larger than 6 times the peak area of cefroxadine from the standard solution.

Operating conditions—

Detector: An ultraviolet absorption photometer (wavelength: 254 nm).

Column: A stainless steel column 4.6 mm in inside diameter and 10 cm in length, packed with octadecylsilanized silica gel for liquid chromatography (5 μm in particle diameter).

Column temperature: A constant temperature of about 25°C.

Mobile phase: Dissolve 1.4 g of sodium perchlorate in 1000 mL of a mixture of water and acetonitrile (489:11).

Flow rate: Adjust so that the retention time of cefroxadine is about 20 minutes.

Time span of measurement: About 2 times as long as the retention time of cefroxadine.

System suitability—

Test for required detectability: Measure exactly 2 mL of the standard solution, and add the mobile phase to make exactly 20 mL. Confirm that the peak area of cefroxadine obtained with 40 μL of this solution is equivalent to 7 to 13% of that with 40 μL of the standard solution.

System performance: Dissolve 3 mg of Cefroxadine Hydrate and 15 mg of orcin in 100 mL of the mobile phase. When the procedure is run with 40 μL of this solution under the above operating conditions, orcin and cefroxadine are eluted in this order with the resolution between these peaks being not less than 3.

System repeatability: When the test is repeated 6 times with 40 μL of the standard solution under the above operating conditions, the relative standard deviation of the peak area of cefroxadine is not more than 2.0%.

Water <2.48> Not less than 8.5% and not more than 12.0% (0.1 g, volumetric titration, direct titration).

Assay Weigh accurately an amount of Cefroxadine Hydrate and Cefroxadine RS, equivalent to about 50 mg (potency), dissolve each in a suitable amount of a mixture of dilute acetic acid and phosphoric acid (500:1), add exactly 5 mL of the internal standard solution and a mixture of dilute acetic acid and phosphoric acid (500:1) to make 200 mL, and use these solutions as the sample solution and standard solution. Perform the test with 10 μL each of the sample solution and standard solution as directed under Liquid Chromatography <2.01> according to the following conditions, and calculate the ratios, Q_T and Q_S , of the peak area of cefroxadine to that of the internal standard.

$$\begin{aligned} \text{Amount } [\mu\text{g (potency)}] \text{ of cefroxadine (C}_{16}\text{H}_{19}\text{N}_3\text{O}_5\text{S)} \\ = M_S \times Q_T / Q_S \times 1000 \end{aligned}$$

M_S : Amount [mg (potency)] of Cefroxadine RS taken

Internal standard solution—Dissolve 1.6 g of vanillin in 5 mL of methanol, and add a mixture of dilute acetic acid and phosphoric acid (500:1) to make 100 mL.

Operating conditions—

Detector: An ultraviolet absorption photometer (wavelength: 254 nm).

Column: A stainless steel column 4.6 mm in inside diameter and 10 cm in length, packed with octadecylsilanized silica gel for liquid chromatography (5 μm in particle diameter).

Column temperature: A constant temperature of about 25°C.

Mobile phase: A mixture of a solution of ammonium sulfate (1 in 50) and acetonitrile (97:3).

Flow rate: Adjust so that the retention time of cefroxadine is about 10 minutes.

System suitability—

System performance: When the procedure is run with 10 μL of the standard solution under the above operating conditions, cefroxadine and the internal standard are eluted in this order with the resolution between these peaks being not

less than 1.5.

System repeatability: When the test is repeated 6 times with 10 μ L of the standard solution under the above operating conditions, the relative standard deviation of the ratios of the peak areas of cefroxadine to that of the internal standard is not more than 1.0%.

Containers and storage Containers—Tight containers.

Cefroxadine for Syrup

シロップ用セフロキサジン

Cefroxadine for Syrup is a preparation for syrup, which is suspended before use.

It contains not less than 93.0% and not more than 107.0% of the labeled potency of cefroxadine ($C_{16}H_{19}N_3O_5S$; 365.40).

Method of preparation Prepare as directed under Preparations for Syrups, with Cefroxadine Hydrate.

Identification Powder Cefroxadine for Syrup, if necessary. To a portion of the powder, equivalent to 2 mg (potency) of Cefroxadine Hydrate, add 100 mL of 0.001 mol/L hydrochloric acid TS, shake well, and filter. Determine the absorption spectrum of this filtrate as directed under Ultraviolet-visible Spectrophotometry <2.24>: it exhibits a maximum between 267 nm and 271 nm.

Water <2.48> Not more than 4.5% (0.1 g, volumetric titration, direct titration).

Uniformity of dosage units <6.02> Perform the test according to the following method: Cefroxadine for Syrup in single-dose packages meet the requirement of the Content uniformity test.

Take out the total contents of 1 package of Cefroxadine for Syrup, add 4V/5 mL of a mixture of dilute acetic acid and phosphoric acid (500:1), shake well for 15 minutes, add exactly 5 mL of the internal standard solution per 50 mg (potency) of Cefroxadine Hydrate, and add a mixture of dilute acetic acid and phosphoric acid (500:1) to make V mL so that each mL contains about 0.25 mg (potency) of Cefroxadine Hydrate. Filter this solution through a membrane filter with pore size of not exceeding 0.45 μ m, and use the filtrate as the sample solution. Separately, weigh accurately an amount of Cefroxadine RS, equivalent to about 50 mg (potency), dissolve in a mixture of dilute acetic acid and phosphoric acid (500:1), add exactly 5 mL of the internal standard solution, add a mixture of dilute acetic acid and phosphoric acid (500:1) to make 200 mL, and use this solution as the standard solution. Then, proceed as directed in the Assay under Cefroxadine Hydrate.

$$\begin{aligned} & \text{Amount [mg (potency)] of cefroxadine (C}_{16}\text{H}_{19}\text{N}_3\text{O}_5\text{S)} \\ & = M_S \times Q_T/Q_S \times V/200 \end{aligned}$$

M_S : Amount [mg (potency)] of Cefroxadine RS taken

Internal standard solution—Dissolve 1.6 g of vanillin in 5 mL of methanol, and add a mixture of dilute acetic acid and phosphoric acid (500:1) to make 100 mL.

Dissolution <6.10> When the test is performed at 50 revolutions per minute according to the Paddle method, using 900 mL of water as the dissolution medium, the dissolution rate in 15 minutes of Cefroxadine for Syrup is not less than 85%.

Start the test with an accurately weighed amount of Cefroxadine for Syrup, equivalent to about 0.1 g (potency)

of Cefroxadine Hydrate, withdraw not less than 10 mL of the medium at the specified minute after starting the test, and filter through a membrane filter with a pore size not exceeding 0.8 μ m. Discard not less than 5 mL of the first filtrate, pipet 4 mL of the subsequent filtrate, add 0.1 mol/L hydrochloric acid TS to make exactly 20 mL, and use this solution as the sample solution. Separately, weigh accurately an amount of Cefroxadine RS, equivalent to about 22 mg (potency), and dissolve in 0.1 mol/L hydrochloric acid TS to make exactly 100 mL. Pipet 5 mL of this solution, add 10 mL of water, add 0.1 mol/L hydrochloric acid TS to make exactly 50 mL, and use this solution as the standard solution. Perform the test with the sample solution and standard solution as directed under Ultraviolet-visible Spectrophotometry <2.24>, and determine the absorbances, A_T and A_S , at 267 nm.

$$\begin{aligned} & \text{Dissolution rate (\%)} \text{ with respect to the labeled amount} \\ & \text{of cefroxadine (C}_{16}\text{H}_{19}\text{N}_3\text{O}_5\text{S)} \\ & = M_S/M_T \times A_T/A_S \times 1/C \times 450 \end{aligned}$$

M_S : Amount [mg (potency)] of Cefroxadine RS taken

M_T : Amount (g) of Cefroxadine for Syrup taken

C: Labeled amount [mg (potency)] of cefroxadine ($C_{16}H_{19}N_3O_5S$) in 1 g

Assay Powder Cefroxadine for Syrup, if necessary, weigh accurately a portion of the powder, equivalent to about 50 mg (potency) of Cefroxadine Hydrate, add 160 mL of a mixture of dilute acetic acid and phosphoric acid (500:1), shake well for 15 minutes, add exactly 5 mL of the internal standard solution, and add a mixture of dilute acetic acid and phosphoric acid (500:1) to make 200 mL. Filter this solution through a membrane filter with a pore size not exceeding 0.45 μ m, and use the filtrate as the sample solution. Separately, weigh accurately an amount of Cefroxadine RS, equivalent to about 50 mg (potency), dissolve in a mixture of dilute acetic acid and phosphoric acid (500:1), add exactly 5 mL of the internal standard solution, add a mixture of dilute acetic acid and phosphoric acid (500:1) to make 200 mL, and use this solution as the standard solution. Proceed as directed in the Assay under Cefroxadine Hydrate.

$$\begin{aligned} & \text{Amount [mg (potency)] of cefroxadine (C}_{16}\text{H}_{19}\text{N}_3\text{O}_5\text{S)} \\ & = M_S \times Q_T/Q_S \end{aligned}$$

M_S : Amount [mg (potency)] of Cefroxadine RS taken

Internal standard solution—Dissolve 1.6 g of vanillin in 5 mL of methanol, and add a mixture of dilute acetic acid and phosphoric acid (500:1) to make 100 mL.

Containers and storage Containers—Tight containers.

Cefsulodin Sodium

セフスロジンナトリウム

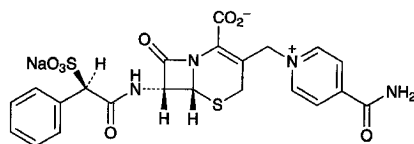

$C_{22}H_{19}N_4NaO_8S_2$: 554.53

Monosodium (6*R*,7*R*)-3-(4-carbamoylpyridinium-1-ylmethyl)-8-oxo-7-[(2*R*)-2-phenyl-2-sulfonatoacetylamino]-5-thia-1-azabicyclo[4.2.0]oct-2-ene-2-carboxylate
[52152-93-9]

Cefsulodin Sodium contains not less than 900 μg (potency) and not more than 970 μg (potency) per mg, calculated on the anhydrous basis. The potency of Cefsulodin Sodium is expressed as mass (potency) of cefsulodin ($C_{22}H_{20}N_4O_8S_2$: 532.55).

Description Cefsulodin Sodium occurs as white to light yellow, crystals or crystalline powder.

It is freely soluble in water and in formamide, slightly soluble in methanol, and very slightly soluble in ethanol (95).

It is hygroscopic.

Identification (1) Determine the absorption spectrum of a solution of Cefsulodin Sodium (1 in 50,000) as directed under Ultraviolet-visible Spectrophotometry <2.24>, and compare the spectrum with the Reference Spectrum or the spectrum of a solution of Cefsulodin Sodium RS prepared in the same manner as sample solution: both spectra exhibit similar intensities of absorption at the same wavelengths.

(2) Determine the infrared absorption spectrum of Cefsulodin Sodium as directed in the potassium bromide disk method under Infrared Spectrophotometry <2.25>, and compare the spectrum with the Reference Spectrum or the spectrum of Cefsulodin Sodium RS: both spectra exhibit similar intensities of absorption at the same wave numbers.

(3) Determine the ^1H spectrum of a solution of Cefsulodin Sodium in heavy water for nuclear magnetic resonance spectroscopy (1 in 10) as directed under Nuclear Magnetic Resonance Spectroscopy <2.21>, using sodium 3-trimethylsilylpropanesulfonate for nuclear magnetic resonance spectroscopy as an internal reference compound: it exhibits a multiplet signal A between δ 7.3 ppm and δ 7.7 ppm, and doublet signals, B and C, at around δ 8.4 ppm and at around δ 9.1 ppm, respectively. The ratio of integrated intensity of these signals, A:B:C, is about 5:2:2.

(4) Cefsulodin Sodium responds to Qualitative Tests <1.09> (1) for sodium salt.

Optical rotation <2.49> $[\alpha]_D^{20}$: +16.5 – +20.0° (0.1 g calculated on the anhydrous basis, water, 10 mL, 100 mm).

pH <2.54> Dissolve 1.0 g of Cefsulodin Sodium in 10 mL of water: the pH of the solution is not less than 3.3 and not more than 4.8.

Purity (1) Clarity of solution—Dissolve 1.0 g of Cefsulodin Sodium in 10 mL of water: the solution is clear.

(2) Heavy metals <1.07>—To 1.0 g of Cefsulodin Sodium add 10 mL of a solution of magnesium nitrate hexahydrate in ethanol (95) (1 in 5), mix, fire the ethanol to burn, then heat gradually to carbonize. After cooling, add 2 mL of nitric acid, heat carefully, then heat at 500 – 600°C to incinerate. If a carbonized residue still retains, add a little amount

of nitric acid, and heat again to incinerate. After cooling, add 6 mL of hydrochloric acid to the residue, heat to dryness on a water bath, then moisten the residue with 3 drops of hydrochloric acid, add 10 mL of hot water, and heat on a water bath to dissolve. Add ammonia TS dropwise to adjust to pH 3 – 4, and add 2 mL of dilute acetic acid. If necessary, filter, wash the crucible and residue on the filter with 10 mL of water, transfer the filtrate and washings into a Nessler tube, add water to make 50 mL, and use this solution as the test solution. Prepare the control solution as follows: To 2.0 mL of Standard Lead Solution add 10 mL of a solution of magnesium nitrate hexahydrate in ethanol (95) (1 in 5), fire the ethanol to burn. After cooling, add 2 mL of nitric acid, heat carefully, then heat at 500 – 600°C. After cooling, add 6 mL of hydrochloric acid, then proceed in the same manner as for the preparation of the test solution (not more than 20 ppm).

(3) Arsenic <1.11>—Prepare the test solution with 1.0 g of Cefsulodin Sodium according to Method 3, using a solution of magnesium nitrate hexahydrate in ethanol (95) (1 in 5) and 15 mL of dilute hydrochloric acid instead of a solution of magnesium nitrate hexahydrate in ethanol (95) (1 in 50) and 3 mL of hydrochloric acid, and perform the test (not more than 2 ppm).

(4) Related substances—Weigh accurately 0.10 g of Cefsulodin Sodium, dissolve in water to make exactly 50 mL, and use this solution as the sample solution. Separately, weigh accurately about 20 mg of isonicotinic acid amide and about 20 mg of Cefsulodin Sodium RS (separately determine the water <2.48> in the same manner as Cefsulodin Sodium), and dissolve in water to make exactly 100 mL. Pipet 10 mL of this solution, add water to make exactly 100 mL, and use this solution as the standard solution. Perform the test with exactly 10 μL each of the sample solution and standard solution as directed under Liquid Chromatography <2.01> according to the following conditions, and determine the areas of each peak by the automatic integration method. Calculate the amount of the related substances by the following formula: the amount of isonicotinic acid amide is not more than 1.0%, and the total amount of other related substances is not more than 1.2%.

$$\begin{aligned} \text{Amount (\%)} \text{ of isonicotinic acid amide} \\ = A/B_1 \times M_1/M_T \times 5 \end{aligned}$$

$$\begin{aligned} \text{Total amount (\%)} \text{ of the other related substances} \\ = B/B_S \times M_S/M_T \times 5 \end{aligned}$$

A: Peak area of isonicotinic acid amide from the sample solution

B: Total peak area other than cefsulodin and other than isonicotinic acid amide from the sample solution

B₁: Peak area of isonicotinic acid amide from the standard solution

B_S: Peak area of cefsulodin from the standard solution

M_T: Amount (g) of Cefsulodin Sodium taken

M_S: Amount (g) of Cefsulodin Sodium RS taken

M₁: Amount (g) of isonicotinic acid amide taken

Operating conditions—

Detector: An ultraviolet absorption photometer (wavelength: 254 nm).

Column: A stainless steel column 4 mm in inside diameter and 15 cm in length, packed with octadecylsilanized silica gel for liquid chromatography (5 μm in particle diameter).

Column temperature: A constant temperature of about 25°C.

Mobile phase A: A mixture of a solution of ammonium sulfate (1 in 100) and acetonitrile (97:3).

Mobile phase B: A mixture of a solution of ammonium

sulfate (1 in 100) and acetonitrile (23:2).

Flowing of mobile phase: Change the mobile phase A to B at 14 minutes after the injection of sample.

Flow rate: Adjust so that the retention time of cefprozil is about 9 minutes.

Time span of measurement: About 4 times as long as the retention time of cefprozil.

System suitability—

Test for required detectability: Pipet 1 mL of the standard solution, add water to make exactly 10 mL. Confirm that the peak areas of isonicotinic acid amide and cefprozil obtained with 10 μ L of this solution are equivalent to 7 to 13% of those with 10 μ L of the standard solution.

System performance: When the procedure is run with 10 μ L of the standard solution under the above operating conditions, isonicotinic acid amide and cefprozil are eluted in this order with the resolution between these peaks being not less than 5.

System repeatability: When the test is repeated 5 times with 10 μ L of the standard solution under the above operating conditions, the relative standard deviation of the peak areas of cefprozil is not more than 1.0%.

Water <2.48> Not more than 5.0% (1 g, volumetric titration, direct titration, avoiding moisture absorption of the sample, using a mixture of formamide for water determination and methanol for water determination (2:1) instead of methanol for water determination).

Assay Weigh accurately an amount of Cefprozil Sodium and Cefprozil Sodium RS, equivalent to about 0.1 g (potency), dissolve each in water to make exactly 50 mL, and use these solutions as the sample solution and standard solution. Perform the test with exactly 10 μ L each of the sample solution and standard solution as directed under Liquid Chromatography <2.01> according to the following conditions, and determine the peak areas, A_T and A_S , of cefprozil in each solution.

$$\begin{aligned} \text{Amount } [\mu\text{g (potency)}] \text{ of cefprozil (C}_{22}\text{H}_{20}\text{N}_4\text{O}_8\text{S}_2) \\ = M_S \times A_T / A_S \times 1000 \end{aligned}$$

M_S : Amount [mg (potency)] of Cefprozil Sodium RS taken

Operating conditions—

Detector: An ultraviolet absorption photometer (wavelength: 254 nm).

Column: A stainless steel column 4 mm in inside diameter and 15 cm in length, packed with octadecylsilanized silica gel for liquid chromatography (5 μ m in particle diameter).

Column temperature: A constant temperature of about 25°C.

Mobile phase: A mixture of a solution of ammonium sulfate (1 in 100) and acetonitrile (97:3).

Flow rate: Adjust so that the retention time of cefprozil is about 9 minutes.

System suitability—

System performance: Dissolve 40 mg of isonicotinic acid amide in 25 mL of the standard solution. When the procedure is run with 10 μ L of this solution under the above operating conditions, isonicotinic acid amide and cefprozil are eluted in this order with the resolution between these peaks being not less than 5.

System repeatability: When the test is repeated 5 times with 10 μ L of the standard solution under the above operating conditions, the relative standard deviation of the peak areas of cefprozil is not more than 1.0%.

Containers and storage Containers—Hermetic containers.

Ceftazidime Hydrate

セフトアジジム水和物

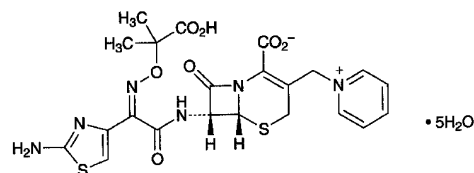

$\text{C}_{22}\text{H}_{22}\text{N}_6\text{O}_7\text{S}_2 \cdot 5\text{H}_2\text{O}$: 636.65

(6*R*,7*R*)-7-[(*Z*)-2-(2-Aminothiazol-4-yl)-2-(1-carboxy-1-methylethoxyimino)acetylamino]-3-(pyridinium-1-ylmethyl)-8-oxo-5-thia-1-azabicyclo[4.2.0]oct-2-ene-2-carboxylate pentahydrate

[78439-06-2]

Ceftazidime Hydrate contains not less than 950 μ g (potency) and not more than 1020 μ g (potency) per mg, calculated on the anhydrous basis. The potency of Ceftazidime Hydrate is expressed as mass (potency) of ceftazidime ($\text{C}_{22}\text{H}_{22}\text{N}_6\text{O}_7\text{S}_2$: 546.58).

Description Ceftazidime Hydrate occurs as a white to light yellow-white crystalline powder.

It is slightly soluble in water, and very slightly soluble in acetonitrile and in ethanol (95).

Identification (1) Determine the absorption spectrum of a solution of Ceftazidime Hydrate in phosphate buffer solution (pH 6.0) (1 in 100,000) as directed under Ultraviolet-visible Spectrophotometry <2.24>, and compare the spectrum with the Reference Spectrum or the spectrum of a solution of Ceftazidime RS prepared in the same manner as the sample solution: both spectra exhibit similar intensities of absorption at the same wavelengths.

(2) Determine the infrared absorption spectrum of Ceftazidime Hydrate as directed in the potassium bromide disk method under Infrared Spectrophotometry <2.25>, and compare the spectrum with the Reference Spectrum or the spectrum of Ceftazidime RS: both spectra exhibit similar intensities of absorption at the same wave numbers.

(3) To 0.05 g of Ceftazidime Hydrate add 5 mg of dried sodium carbonate, and add 0.5 mL of heavy water for nuclear magnetic resonance spectroscopy to dissolve. Determine the ^1H spectrum of this solution as directed under Nuclear Magnetic Resonance Spectroscopy <2.21>, using sodium 3-trimethylsilylpropanesulfonate for nuclear magnetic resonance spectroscopy as an internal reference compound: it exhibits singlet signals, A and B, at around δ 1.5 ppm and at around δ 6.9 ppm, and a multiplet signal C between δ 7.9 ppm and δ 9.2 ppm. The ratio of integrated intensity of each signal, A:B:C, is about 6:1:5.

Optical rotation <2.49> $[\alpha]_D^{20}$: -28 – -34° (0.5 g calculated on the anhydrous basis, phosphate buffer solution (pH 6.0), 100 mL, 100 mm).

pH <2.54> Dissolve 0.5 g of Ceftazidime Hydrate in 100 mL of water: the pH of the solution is between 3.0 and 4.0.

Purity (1) Clarity and color of solution—Dissolve 1.0 g of Ceftazidime Hydrate in 10 mL of a solution obtained by dissolving 5 g of anhydrous disodium hydrogen phosphate and 1 g of potassium dihydrogen phosphate in water to make 100 mL: the solution is clear, and its absorbance at 420 nm, determined as directed under Ultraviolet-visible Spectrophotometry <2.24>, is not more than 0.20.

(2) Heavy metals <1.07>—Proceed with 1.0 g of Cefotaxime Hydrate according to Method 2, and perform the test. Prepare the control solution with 2.0 mL of Standard Lead Solution (not more than 20 ppm).

(3) Related substances (i) Trityl-*t*-butyl substance and *t*-butyl substance—Dissolve 0.10 g of Cefotaxime Hydrate in 2 mL of diluted disodium hydrogen phosphate TS (1 in 3), and use this solution as the sample solution. Pipet 1 mL of the sample solution, add diluted disodium hydrogen-phosphate TS (1 in 3) to make exactly 100 mL, and use this solution as the standard solution. Perform the test with these solutions as directed under Thin-layer Chromatography <2.03>. Spot 2 μ L each of the sample solution and standard solution on a plate of silica gel with fluorescent indicator for thin-layer chromatography. Develop with a mixture of acetic acid (100), *n*-butyl acetate, acetate buffer solution (pH 4.5) and 1-butanol (16:16:13:3) to a distance of about 12 cm, and air-dry the plate. Examine under ultraviolet light (main wavelength: 254 nm): the spots which appear upper in position than the principal spot obtained from the sample solution are not more intense than the spot from the standard solution.

(ii) Other related substances—Dissolve 20 mg of Cefotaxime Hydrate in 10 mL of the mobile phase, and use this solution as the sample solution. Pipet 1 mL of the sample solution, add the mobile phase to make exactly 200 mL, and use this solution as the standard solution. Perform the test with exactly 5 μ L each of the sample solution and standard solution as directed under Liquid Chromatography <2.01> according to the following conditions, and determine each peak area by the automatic integration method: the area of the peak other than cefotaxime obtained from the sample solution is not larger than that of cefotaxime from the standard solution, and the total of peak areas other than cefotaxime from the sample solution is not larger than 5 times the peak area of cefotaxime from the standard solution.

Operating conditions—

Detector: An ultraviolet absorption photometer (wavelength: 254 nm).

Column: A stainless steel column 4.6 mm in inside diameter and 20 cm in length, packed with octadecylsilanized silica gel for liquid chromatography (5 μ m in particle diameter).

Column temperature: A constant temperature of about 25°C.

Mobile phase: Dissolve 5.0 g of ammonium dihydrogen-phosphate in 750 mL of water, adjust to pH 3.5 with phosphoric acid, and add water to make 870 mL. To this solution add 130 mL of acetonitrile.

Flow rate: Adjust so that the retention time of cefotaxime is about 4 minutes.

Time span of measurement: About 3 times as long as the retention time of cefotaxime, beginning after the solvent peak.

System suitability—

Test for required detectability: Pipet 1 mL of the standard solution, add the mobile phase to make exactly 5 mL, and confirm that the peak area of cefotaxime obtained with 5 μ L of this solution is equivalent to 15 to 25% of that with 5 μ L of the standard solution.

System performance: Dissolve about 10 mg each of Cefotaxime Hydrate and acetanilide in 20 mL of the mobile phase. When the procedure is run with 5 μ L of this solution under the above operating conditions, cefotaxime and acetanilide are eluted in this order with the resolution between these peaks being not less than 10.

System repeatability: When the test is repeated 6 times

with 5 μ L of the standard solution under the above operating conditions, the relative standard deviation of the peak area of cefotaxime is not more than 2.0%.

(4) Free pyridine—Weigh accurately about 50 mg of Cefotaxime Hydrate, dissolve in the mobile phase to make exactly 10 mL, and use this solution as the sample solution. Separately, weigh accurately about 0.1 g of pyridine, and add the mobile phase to make exactly 100 mL. Pipet 1 mL of this solution, add the mobile phase to make exactly 100 mL, and use this solution as the standard solution. Perform the test with exactly 10 μ L each of the sample solution and standard solution as directed under Liquid Chromatography <2.01> according to the following conditions, and determine the peak heights, H_T and H_S , of pyridine in each solution: the amount of free pyridine is not more than 0.3%.

$$\begin{aligned} \text{Amount (mg) of free pyridine} \\ = M_S \times H_T / H_S \times 1/1000 \end{aligned}$$

M_S : Amount (mg) of pyridine taken

Operating conditions—

Detector: An ultraviolet absorption photometer (wavelength: 254 nm).

Column: A stainless steel column 4.6 mm in inside diameter and 20 cm in length, packed with octadecylsilanized silica gel for liquid chromatography (5 μ m in particle diameter).

Column temperature: A constant temperature of about 40°C.

Mobile phase: Dissolve 2.88 g of ammonium dihydrogen-phosphate in 500 mL of water, add 300 mL of acetonitrile and water to make 1000 mL, and adjust to pH 7.0 with ammonia solution (28).

Flow rate: Adjust so that the retention time of pyridine is about 4 minutes.

System suitability—

System performance: Dissolve 5 mg of Cefotaxime Hydrate in 100 mL of a solution of pyridine in the mobile phase (1 in 20,000). When the procedure is run with 10 μ L of this solution under the above operating conditions, cefotaxime and pyridine are eluted in this order with the resolution between these peaks being not less than 9.

System repeatability: When the test is repeated 6 times with 10 μ L of the standard solution under the above operating conditions, the relative standard deviation of the peak height of pyridine is not more than 5.0%.

Water <2.48> 13.0 – 15.0% (0.1 g, volumetric titration, direct titration).

Assay Weigh accurately an amount of Cefotaxime Hydrate, equivalent to about 0.1 g (potency), and dissolve in 0.05 mol/L phosphate buffer solution (pH 7.0) to make exactly 100 mL. Pipet 10 mL of this solution, add exactly 5 mL of the internal standard solution, then add 0.05 mol/L phosphate buffer solution (pH 7.0) to make 50 mL, and use this solution as the sample solution. Separately, weigh accurately an amount of Cefotaxime RS, equivalent to about 20 mg (potency), dissolve in 0.05 mol/L phosphate buffer solution (pH 7.0) to make exactly 20 mL. Pipet 10 mL of this solution, add exactly 5 mL of the internal standard solution, then add 0.05 mol/L phosphate buffer solution (pH 7.0) to make 50 mL, and use this solution as the standard solution. Perform the test with 5 μ L each of the sample solution and standard solution as directed under Liquid Chromatography <2.01> according to the following conditions, and calculate the ratios, Q_T and Q_S , of the peak area of cefotaxime to that of the internal standard.

Amount [μg (potency)] of ceftazidime ($\text{C}_{22}\text{H}_{22}\text{N}_6\text{O}_7\text{S}_2$)
 $= M_S \times Q_T/Q_S \times 5000$

M_S : Amount [mg (potency)] of Cefazidime RS taken

Internal standard solution—A solution of dimedon in 0.05 mol/L phosphate buffer solution (pH 7.0) (11 in 10,000).

Operating conditions—

Detector: An ultraviolet absorption photometer (wavelength: 254 nm).

Column: A stainless steel column 4.6 mm in inside diameter and 10 cm in length, packed with hexasilanized silica gel for liquid chromatography (5 μm in particle diameter).

Column temperature: A constant temperature of about 25°C.

Mobile phase: Dissolve 4.26 g of anhydrous disodium hydrogen phosphate and 2.72 g of potassium dihydrogen phosphate in 980 mL of water, and add 20 mL of acetonitrile.

Flow rate: Adjust so that the retention time of ceftazidime is about 4 minutes.

System suitability—

System performance: When the procedure is run with 5 μL of the standard solution under the above operating conditions, the internal standard and ceftazidime are eluted in this order with the resolution between these peaks being not less than 3.

System repeatability: When the test is repeated 6 times with 5 μL of the standard solution under the above operating conditions, the relative standard deviation of the ratios of the peak area of ceftazidime to that of the internal standard is not more than 1.0%.

Containers and storage Containers—Tight containers.

Storage—Light-resistant.

Ceftazidime for Injection

注射用セフトジジム

Ceftazidime for Injection is a preparation for injection which is dissolved before use.

It contains not less than 93.0% and not more than 107.0% of the labeled potency of ceftazidime ($\text{C}_{22}\text{H}_{22}\text{N}_6\text{O}_7\text{S}_2$; 546.58).

Method of preparation Prepare as directed under Injections, with Cefazidime Hydrate.

Description Cefazidime for Injection is a white to pale yellow-white powder.

Identification Determine the absorption spectrum of a solution of Cefazidime for Injection (1 in 100,000) in phosphate buffer solution (pH 6.0) as directed under Ultraviolet-visible Spectrophotometry <2.24>: it exhibits a maximum between 255 nm and 259 nm.

pH <2.54> Dissolve an amount of Cefazidime for Injection, equivalent to 1.0 g (potency) of Cefazidime Hydrate, in 10 mL of water: the pH of this solution is 5.8 to 7.8.

Purity Clarity and color of solution—Dissolve 5 g of disodium hydrogen phosphate and 1 g of potassium dihydrogen phosphate in water to make 100 mL. In 10 mL of this solution dissolve an amount of Cefazidime for Injection, equivalent to 1.0 g (potency) of Cefazidime Hydrate: the solution is clear. Also, determine the absorption spectra of this solution as directed under Ultraviolet-visible Spectropho-

tometry <2.24>: the absorbance at 420 nm is not more than 0.3.

Loss on drying <2.41> Not more than 14.0% (0.1 g, in vacuum not exceeding 0.67 kPa, 60°C, 3 hours).

Bacterial endotoxins <4.01> Less than 0.067 EU/mg (potency).

Uniformity of dosage units <6.02> It meets the requirement of the Mass variation test.

Foreign insoluble matter <6.06> Perform the test according to Method 2: it meets the requirement.

Insoluble particulate matter <6.07> It meets the requirement.

Sterility <4.06> Perform the test according to the Membrane filter method: it meets the requirement.

Assay Weigh accurately the mass of the contents of not less than 10 containers of Cefazidime for Injection. Weigh accurately an amount of Cefazidime Hydrate, equivalent to about 0.25 g (potency), and dissolve in 0.05 mol/L phosphate buffer solution (pH 7.0) to make exactly 250 mL. Pipet 10 mL of this solution, add exactly 5 mL of the internal standard solution, add more 0.05 mol/L phosphate buffer solution (pH 7.0) to make 50 mL, and use this solution as the sample solution. Separately, weigh accurately an amount of Cefazidime RS, equivalent to about 25 mg (potency), and dissolve in 0.05 mol/L phosphate buffer solution (pH 7.0) to make exactly 25 mL. Pipet 10 mL of this solution, add exactly 5 mL of the internal standard solution, then add 0.05 mol/L phosphate buffer solution (pH 7.0) to make 50 mL, and use this solution as the standard solution. Then, proceed as directed in the Assay under Cefazidime Hydrate.

Amount [mg (potency)] of ceftazidime ($\text{C}_{22}\text{H}_{22}\text{N}_6\text{O}_7\text{S}_2$)
 $= M_S \times Q_T/Q_S \times 10$

M_S : Amount [mg (potency)] of Cefazidime RS taken

Internal standard solution—A solution of dimedon in 0.05 mol/L phosphate buffer solution (pH 7.0) (11 in 10,000).

Containers and storage Containers—Hermetic containers.

Storage—Light-resistant.

Cefteram Pivoxil

セフテラム ピボキシル

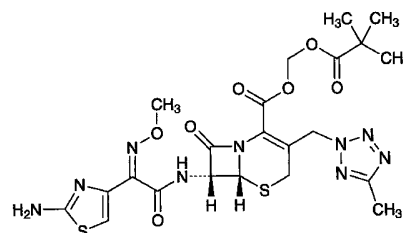

$\text{C}_{22}\text{H}_{27}\text{N}_9\text{O}_7\text{S}_2$; 593.64

2,2-Dimethylpropanoyloxymethyl (6R,7R)-7-[(Z)-2-(2-aminothiazol-4-yl)-2-(methoxyimino)acetyl]amino-3-(5-methyl-2H-tetrazol-2-ylmethyl)-8-oxo-5-thia-1-azabicyclo[4.2.0]oct-2-ene-2-carboxylate
 [82547-58-8, Cefteram]

Cefteram Pivoxil contains not less than 743 μg (potency) and not more than 824 μg (potency) per mg,

calculated on the anhydrous basis. The potency of Cefteram Pivoxil is expressed as mass (potency) of cefteram ($C_{16}H_{17}N_9O_5S_2$; 479.49).

Description Cefteram Pivoxil occurs as a white to pale yellow-white powder.

It is very soluble in acetonitrile, freely soluble in methanol, in ethanol (95) and in chloroform, and practically insoluble in water.

Identification (1) Determine the absorption spectrum of a solution of Cefteram Pivoxil in 0.05 mol/L hydrochloric acid-methanol TS (1 in 100,000) as directed under Ultraviolet-visible Spectrophotometry <2.24>, and compare the spectrum with the Reference Spectrum: both spectra exhibit similar intensities of absorption at the same wavelengths.

(2) Determine the infrared absorption spectrum of Cefteram Pivoxil as directed in the potassium bromide disk method under Infrared Spectrophotometry <2.25>, and compare the spectrum with the Reference Spectrum: both spectra exhibit similar intensities of absorption at the same wave numbers.

(3) Determine the 1H spectrum of a solution of Cefteram Pivoxil in deuterated chloroform for nuclear magnetic resonance spectroscopy (1 in 10) as directed under Nuclear Magnetic Resonance Spectroscopy <2.21>, using tetramethylsilane for nuclear magnetic resonance spectroscopy as an internal reference compound: it exhibits singlet signals A, B and C, at around δ 1.2 ppm, at around δ 2.5 ppm and at around δ 4.0 ppm, respectively. The ratio of the integrated intensity of these signals, A:B:C, is about 3:1:1.

Optical rotation <2.49> $[\alpha]_D^{20}$: +35 – +43° (0.4 g calculated on the anhydrous basis, methanol, 20 mL, 100 mm).

Purity (1) Heavy metals <1.07>—Proceed with 1.0 g of Cefteram Pivoxil according to Method 2, and perform the test. Prepare the control solution with 2.0 mL of Standard Lead Solution (not more than 20 ppm).

(2) Related substances—Dissolve 50 mg of Cefteram Pivoxil in 50 mL of the mobile phase, and use this solution as the sample solution. Pipet 1 mL of the sample solution, add the mobile phase to make exactly 50 mL, and use this solution as the standard solution. Perform the test with exactly 10 μ L each of the sample solution and standard solution as directed under Liquid Chromatography <2.01> according to the following conditions, and determine each peak area by the automatic integration method: the each area of the peaks, having the relative retention time of about 0.2 and about 0.9 to cefteram pivoxil, obtained from the sample solution is not larger than 1/2 times and 1.25 times the peak area of cefteram pivoxil from the standard solution, respectively, the area of the peak other than cefteram pivoxil and the peaks mentioned above is not larger than 1/4 times the peak area of cefteram pivoxil from the standard solution, and the total area of the peaks other than cefteram pivoxil is not larger than 2.75 times the peak area of cefteram pivoxil from the standard solution. For the area of the peak, having the relative retention time of about 0.1 to cefteram pivoxil, multiply the correction factor, 0.74.

Operating conditions—

Detector, column, column temperature, mobile phase, and flow rate: Proceed as directed in the operating conditions in the Assay.

Time span of measurement: About 2 times as long as the retention time of cefteram pivoxil.

System suitability—

Test for required detectability: To exactly 1 mL of the standard solution add the mobile phase to make exactly 10

mL. Confirm that the peak area of cefteram pivoxil obtained with 10 μ L of this solution is equivalent to 7 to 13% of that with 10 μ L of the standard solution.

System performance: When the procedure is run with 10 μ L of the standard solution under the above operating conditions, the number of theoretical plates and the symmetry factor of the peak of cefteram pivoxil are not less than 5000 and not more than 1.5, respectively.

System repeatability: When the test is repeated 6 times with 10 μ L of the standard solution under the above operating conditions, the relative standard deviation of the peak area of cefteram pivoxil is not more than 3.0%.

Water <2.48> Not more than 3.0% (0.3 g, coulometric titration).

Assay Weigh accurately an amount of Cefteram Pivoxil and Cefteram Pivoxil Mesitylene Sulfonate RS, equivalent to about 40 mg (potency), dissolve each in 20 mL of diluted acetonitrile (1 in 2), add exactly 5 mL of the internal standard solution and diluted acetonitrile (1 in 2) to make 50 mL, and use these solutions as the sample solution and standard solution. Perform the test with 10 μ L each of the sample solution and standard solution as directed under Liquid Chromatography <2.01> according to the following conditions, and calculate the ratios, Q_T and Q_S , of the peak area of cefteram pivoxil to that of the internal standard.

$$\begin{aligned} \text{Amount } [\mu\text{g (potency)}] \text{ of cefteram } (C_{16}H_{17}N_9O_5S_2) \\ = M_S \times Q_T / Q_S \times 1000 \end{aligned}$$

M_S : Amount [mg (potency)] of Cefteram Pivoxil Mesitylene Sulfonate RS taken

Internal standard solution—A solution of methyl parahydroxybenzoate in diluted acetonitrile (1 in 2) (1 in 1000).

Operating conditions—

Detector: An ultraviolet absorption photometer (wavelength: 254 nm).

Column: A stainless steel column 4.6 mm in inside diameter and 15 cm in length, packed with octadecylsilanized silica gel for liquid chromatography (5 μ m in particle diameter).

Column temperature: A constant temperature of about 25°C.

Mobile phase: To 100 mL of acetic acid-sodium acetate buffer solution (pH 5.0) add 375 mL of acetonitrile and water to make 1000 mL.

Flow rate: Adjust so that the retention time of cefteram pivoxil is about 14 minutes.

System suitability—

System performance: When the procedure is run with 10 μ L of the standard solution under the above operating conditions, the internal standard and cefteram pivoxil are eluted in this order with the resolution between these peaks being not less than 3.

System repeatability: When the test is repeated 6 times with 10 μ L of the standard solution under the above operating conditions, the relative standard deviation of the ratios of the peak area of cefteram pivoxil to that of the internal standard is not more than 1.0%.

Containers and storage Containers—Tight containers.

Storage—In a cold place.

Cefteram Pivoxil Fine Granules

セフテラム ピボキシル細粒

Cefteram Pivoxil Fine Granules contain not less than 90.0% and not more than 110.0% of the labeled potency of cefteram ($C_{16}H_{17}N_9O_5S_2$; 479.49).

Method of preparation Prepare as directed under Granules, with Cefteram Pivoxil.

Identification Powder Cefteram Pivoxil Fine Granules. To a portion of the powder, equivalent to 0.1 g (potency) of Cefteram Pivoxil, add 20 mL of methanol, shake well, and filter. To 1 mL of the filtrate add 0.05 mol/L hydrochloric acid-methanol TS to make 500 mL, and determine the absorption spectrum as directed under Ultraviolet-visible Spectrophotometry <2.24>: it exhibits a maximum between 262 nm and 266 nm.

Purity Related substances—Powder Cefteram Pivoxil Fine Granules, if necessary. To a portion, equivalent to 0.1 g (potency) of Cefteram Pivoxil, add diluted acetonitrile (1 in 2) to make 100 mL, disperse the particle by sonicating, then filter, and use the filtrate as the sample solution. Pipet 1 mL of the sample solution, add the mobile phase to make exactly 50 mL, and use this solution as the standard solution. Perform the test with exactly 10 μ L each of the sample solution and standard solution as directed under Liquid Chromatography <2.01> according to the following conditions, and determine each peak area by the automatic integration method: the area of the peak, having the relative retention time of about 0.9 to cefteram pivoxil obtained from the sample solution, is not larger than 1.75 times the peak area of cefteram pivoxil obtained from the standard solution, the area of the peak, having the relative retention time of about 0.1 from the sample solution, is not larger than 17/25 times the peak area of cefteram pivoxil from the standard solution, and the total area of the peaks other than cefteram pivoxil from the sample solution is not larger than 3.7 times the peak area of cefteram pivoxil from the standard solution. For the area of the peak, having the relative retention time of about 0.1 to cefteram pivoxil, multiply the correction factor, 0.74.

Operating conditions—

Proceed as directed in the operating conditions in the Purity (2) under Cefteram Pivoxil.

System suitability—

Proceed as directed in the system suitability in the Purity (2) under Cefteram Pivoxil.

Water <2.48> Not more than 0.3% (0.1 g (potency), coulometric titration).

Uniformity of dosage units <6.02> The Granules in single-dose packages meet the requirement of the Mass variation test.

Dissolution Being specified separately when the drug is granted approval based on the Law.

Assay Powder Cefteram Pivoxil Fine Granules, if necessary. Weigh accurately an amount of the powder, equivalent to about 0.3 g (potency) of Cefteram Pivoxil, add exactly 30 mL of the internal standard solution and diluted acetonitrile (1 in 2) to make 300 mL. Disperse the particle by sonicating, then filter, and use the filtrate as the sample solution. Separately, weigh accurately an amount of Cefteram Pivoxil Mesitylene Sulfonate RS, equivalent to about 50 mg (potency), dissolve in 20 mL of diluted acetonitrile (1 in 2), add ex-

actly 5 mL of the internal standard solution and diluted acetonitrile (1 in 2) to make 50 mL, and use this solution as the standard solution. Perform the test with 10 μ L each of the sample solution and standard solution as directed under Liquid Chromatography <2.01> according to the following conditions, and calculate the ratios, Q_T and Q_S , of the peak area of cefteram pivoxil to that of the internal standard.

$$\begin{aligned} & \text{Amount [mg (potency)] of cefteram } (C_{16}H_{17}N_9O_5S_2) \\ & = M_S \times Q_T / Q_S \times 6 \end{aligned}$$

M_S : Amount [mg (potency)] of Cefteram Pivoxil Mesitylene Sulfonate RS taken

Internal standard solution—A solution of methyl parahydroxybenzoate in diluted acetonitrile (1:2) (1 in 1000).

Operating conditions—

Proceed as directed in the operating conditions in the Assay under Cefteram Pivoxil.

System suitability—

Proceed as directed in the system suitability in the Assay under Cefteram Pivoxil.

Containers and storage Containers—Tight containers.

Cefteram Pivoxil Tablets

セフテラム ピボキシル錠

Cefteram Pivoxil Tablets contain not less than 90.0% and not more than 110.0% of the labeled potency of cefteram ($C_{16}H_{17}N_9O_5S_2$; 479.49).

Method of preparation Prepare as directed under Tablets, with Cefteram Pivoxil.

Identification To a quantity of powdered Cefteram Pivoxil Tablets, equivalent to 0.1 g (potency) of Cefteram Pivoxil, add 20 mL of methanol, shake well, and filter. To 1 mL of the filtrate add 0.05 mol/L hydrochloric acid-methanol TS to make 500 mL. Determine the absorption spectrum of this solution as directed under Ultraviolet-visible Spectrophotometry <2.24>: it exhibits a maximum between 262 nm and 266 nm.

Purity Related substances—To a quantity of powdered Cefteram Pivoxil Tablets, equivalent to 0.1 g (potency) of Cefteram Pivoxil, add diluted acetonitrile (1 in 2) to make 100 mL. Disperse this solution by sonicating, filter, and use the filtrate as the sample solution. Pipet 1 mL of the sample solution, add the mobile phase to make exactly 50 mL and use this solution as the standard solution. Perform the test with exactly 10 μ L each of the sample solution and standard solution as directed under Liquid Chromatography <2.01> according to the following conditions. Determine each peak area of both solutions by the automatic integration method: the area of the peak, having the relative retention time of about 0.9 to cefteram pivoxil, obtained from the sample solution is not larger than 1.75 times the peak area of cefteram pivoxil from the standard solution, and the area of the peak, having the relative retention time of about 0.1 from the sample solution is not larger than 17/25 times the peak area of cefteram pivoxil from the standard solution. Furthermore, the total area of the peaks other than cefteram pivoxil from the sample solution is not larger than 3.7 times the peak area of cefteram pivoxil from the standard solution. For the area of the peak, having the relative retention time of about 0.1 to cefteram pivoxil, multiply the correction factor, 0.74.

Operating conditions—

Proceed as directed in the operating conditions in the Purity (2) under Cefteram Pivoxil.

System suitability—

Proceed as directed in the system suitability in the Purity (2) under Cefteram Pivoxil.

Water <2.48> Not more than 4.0% (a quantity equivalent to 0.2 g (potency) of powdered Cefteram Pivoxil Tablets, volumetric titration, direct titration).

Uniformity of dosage units <6.02> Perform the Mass variation test, or the Content uniformity test according to the following method: it meets the requirement.

To 1 tablet of Cefteram Pivoxil Tablets add exactly 5 mL of the internal standard solution per 50 mg (potency) of Cefteram Pivoxil, and add diluted acetonitrile (1 in 2) to make V mL so that each mL contains about 1 mg (potency) of Cefteram Pivoxil. Disperse this solution by sonicating, filter through a membrane filter with pore size of not exceeding $0.45\ \mu\text{m}$, discard the first 10 mL of the filtrate, and use the subsequent filtrate as the sample solution. Separately, weigh accurately an amount of Cefteram Pivoxil Mesitylene Sulfonate RS, equivalent to about 50 mg (potency), dissolve in 20 mL of diluted acetonitrile (1 in 2), add exactly 5 mL of the internal standard solution, add diluted acetonitrile (1 in 2) to make 50 mL, and use this solution as the standard solution. Then, proceed as directed in the Assay under Cefteram Pivoxil.

$$\begin{aligned} \text{Amount [mg (potency)] of cefteram (C}_{16}\text{H}_{17}\text{N}_9\text{O}_5\text{S}_2) \\ = M_S \times Q_T/Q_S \times V/50 \end{aligned}$$

M_S : Amount [mg (potency)] of Cefteram Pivoxil Mesitylene Sulfonate RS taken

Internal standard solution—A solution of methyl parahydroxybenzoate in diluted acetonitrile (1 in 2) (1 in 1000).

Dissolution <6.10> When the test is performed at 75 revolutions per minute according to the Paddle method, using 900 mL of water as the dissolution medium, the dissolution rate in 30 minutes of Cefteram Pivoxil Tablets is not less than 75%.

Start the test with 1 tablet of Cefteram Pivoxil Tablets, withdraw not less than 20 mL of the medium at the specified minute after starting the test, and filter through a membrane filter with a pore size not exceeding $0.45\ \mu\text{m}$. Discard not less than 10 mL of the first filtrate, pipet V mL of the subsequent filtrate, add water to make exactly V' mL so that each mL contains about $22\ \mu\text{g}$ (potency) of Cefteram Pivoxil, and use this solution as the sample solution. Separately, weigh accurately an amount of Cefteram Pivoxil Mesitylene Sulfonate RS, equivalent to about 22 mg (potency), and dissolve in 20 mL of methanol, and add water to make exactly 50 mL. Pipet 5 mL of this solution, add water to make exactly 100 mL, and use this solution as the standard solution. Perform the test with the sample solution and standard solution as directed under Ultraviolet-visible Spectrophotometry <2.24>, using water as the blank, and determine the absorbances, A_T and A_S , at 300 nm.

$$\begin{aligned} \text{Dissolution rate (\%)} \text{ with respect to the labeled amount} \\ \text{of cefteram (C}_{16}\text{H}_{17}\text{N}_9\text{O}_5\text{S}_2) \\ = M_S \times A_T/A_S \times V'/V \times 1/C \times 90 \end{aligned}$$

M_S : Amount [mg (potency)] of Cefteram Pivoxil Mesitylene Sulfonate RS taken

C : Labeled amount [mg (potency)] of cefteram ($\text{C}_{16}\text{H}_{17}\text{N}_9\text{O}_5\text{S}_2$) in 1 tablet

Assay To a number of tablet of Cefteram Pivoxil Tablets, equivalent to about 1.0 g (potency) of Cefteram Pivoxil, add 120 mL of diluted acetonitrile (1 in 2), disperse by sonicating, and add diluted acetonitrile (1 in 2) to make exactly 200 mL. Centrifuge this solution, pipet 10 mL of the supernatant liquid, add exactly 5 mL of the internal standard solution, add diluted acetonitrile (1 in 2) to make 50 mL, filter through a membrane filter with pore size not exceeding $0.45\ \mu\text{m}$, discard the first 3 mL of the filtrate, and use the subsequent filtrate as the sample solution. Separately, weigh accurately an amount of Cefteram Pivoxil Mesitylene Sulfonate RS, equivalent to about 50 mg (potency), dissolve in 20 mL of diluted acetonitrile (1 in 2), add exactly 5 mL of the internal standard solution, add diluted acetonitrile (1 in 2) to make 50 mL, and use this solution as the standard solution. Then, proceed as directed in the Assay under Cefteram Pivoxil.

$$\begin{aligned} \text{Amount [mg (potency)] of cefteram (C}_{16}\text{H}_{17}\text{N}_9\text{O}_5\text{S}_2) \\ = M_S \times Q_T/Q_S \times 20 \end{aligned}$$

M_S : Amount [mg (potency)] of Cefteram Pivoxil Mesitylene Sulfonate RS taken

Internal standard solution—A solution of methyl parahydroxybenzoate in diluted acetonitrile (1 in 2) (1 in 1000).

Containers and storage Containers—Tight containers.

Storage—Light-resistant.

Ceftibuten Hydrate

セフチブテン水和物

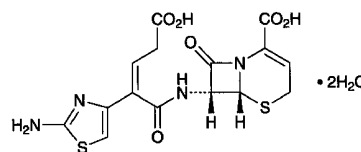

$\text{C}_{15}\text{H}_{14}\text{N}_4\text{O}_6\text{S}_2 \cdot 2\text{H}_2\text{O}$: 446.46

(6*R*,7*R*)-7-[(2*Z*)-2-(2-Aminothiazol-4-yl)-4-carboxybut-2-enoylamino]-8-oxo-5-thia-1-azabicyclo[4.2.0]oct-2-ene-2-carboxylic acid dihydrate

[118081-34-8]

Ceftibuten Hydrate contains not less than $900\ \mu\text{g}$ (potency) and not more than $1020\ \mu\text{g}$ (potency) per mg, calculated on the anhydrous basis. The potency of Ceftibuten Hydrate is expressed as mass (potency) of ceftibuten ($\text{C}_{15}\text{H}_{14}\text{N}_4\text{O}_6\text{S}_2$: 410.42).

Description Ceftibuten Hydrate occurs as a white to pale yellow-white crystalline powder.

It is freely soluble in *N,N*-dimethylformamide and in dimethyl sulfoxide, and practically insoluble in water, in ethanol (95) and in diethyl ether.

Identification (1) Determine the absorption spectrum of a solution of Ceftibuten Hydrate in 0.1 mol/L phosphate buffer solution for antibiotics (pH 8.0) (1 in 50,000) as directed under Ultraviolet-visible Spectrophotometry <2.24>, and compare the spectrum with the Reference Spectrum: both spectra exhibit similar intensities of absorption at the same wavelengths.

(2) Determine the infrared absorption spectrum of Ceftibuten Hydrate as directed in the paste method under the Infrared Spectrophotometry <2.25>, and compare the spectrum with the Reference Spectrum: both spectra exhibit

similar intensities of absorption at the same wave numbers.

(3) Determine the ^1H spectrum of a solution of Ceftributen Hydrate in deuterated dimethyl sulfoxide for nuclear magnetic resonance spectroscopy (1 in 30), using tetramethylsilane for nuclear magnetic resonance spectroscopy as an internal reference compound, as directed under Nuclear Magnetic Resonance Spectroscopy <2.21>: it exhibits doublet signals A and B, at around δ 3.2 ppm and at around δ 5.1 ppm, a quartet signal C, at around δ 5.8 ppm, and a singlet signal D, at around δ 6.3 ppm. The ratio of integrated intensity of each signal except the signal at around δ 3.2 ppm, B:C:D is about 1:1:1.

Optical rotation <2.49> $[\alpha]_D^{20}$: +135 – +155° (0.3 g calculated on the anhydrous basis, 0.1 mol/L phosphate buffer solution for antibiotics, pH 8.0, 50 mL, 100 mm).

Purity (1) Heavy metals <1.07>—Proceed with 2.0 g of Ceftributen Hydrate according to Method 2, and perform the test. Prepare the control solution with 2.0 mL of Standard Lead Solution (not more than 10 ppm).

(2) Related substances—(i) Keep the sample solution and the standard solution at not exceeding 5°C and use within 2 hours after preparation. Dissolve 25 mg of Ceftributen Hydrate in 20 mL of 0.1 mol/L phosphate buffer solution for antibiotics (pH 8.0). To 4 mL of this solution add 0.1 mol/L phosphate buffer solution for antibiotics (pH 8.0) to make 20 mL, and use this solution as the sample solution. Pipet 5 mL of the sample solution, add 0.1 mol/L phosphate buffer solution for antibiotics (pH 8.0) to make exactly 100 mL, and use this solution as the standard solution. Perform the test with exactly 5 μL each of the sample solution and standard solution as directed under Liquid Chromatography <2.01> according to the following conditions, and determine each peak area by the automatic integration method: the area of the peak other than ceftributen obtained from the sample solution is not larger than 1/5 times the peak area of ceftributen from the standard solution, and the total area of the peaks other than ceftributen from the sample solution is not larger than the peak area of ceftributen from the standard solution.

Operating conditions—

Detector, column, column temperature, mobile phase, and flow rate: Proceed as directed in the operating conditions in the Assay.

Time span of measurement: About 1.7 times as long as the retention time of ceftributen, beginning after the solvent peak.

System suitability—

Test for required detectability: Pipet 2 mL of the standard solution, and add 0.1 mol/L phosphate buffer solution for antibiotics (pH 8.0) to make exactly 20 mL. Confirm that the peak area of ceftributen obtained with 5 μL of this solution is equivalent to 7 to 13% of that with 5 μL of the standard solution.

System performance: Dissolve 5 mg of Ceftributen Hydrate in 20 mL of 0.1 mol/L hydrochloric acid TS, and allow to stand at 40°C for 1 hour. To 4 mL of this solution add 0.1 mol/L phosphate buffer solution for antibiotics (pH 8.0) to make 25 mL. When the procedure is run with 5 μL of this solution under the above operating conditions, trans-isomer of ceftributen and ceftributen are eluted in this order with the resolution between these peaks being not less than 2.0.

System repeatability: When the test is repeated 5 times with 5 μL of the standard solution under the above operating conditions, the relative standard deviation of the peak area of ceftributen is not more than 2.0%.

(ii) Keep the sample solution at not exceeding 5°C, and

use within 24 hours after preparation. To 5 mg of Ceftributen Hydrate add 20 mL of the mobile phase, sonicate, if necessary, then shake to dissolve, filter through a membrane filter with a pore size not exceeding 0.45 μm , and use the filtrate as the sample solution. Perform the test with 10 μL of the sample solution as directed under Liquid Chromatography <2.01> according to the following conditions. Determine each peak area by the automatic integration method, and calculate their amounts by the area percentage method: the total amount of the peaks that are eluted faster than ceftributen is not more than 5.0%. For the areas of these peaks, multiply the correction factor, 1.63, respectively.

Operating conditions—

Detector: An ultraviolet absorption photometer (wavelength: 263 nm).

Column: A stainless steel column 7.5 mm in inside diameter and 60 cm in length, packed with glycol etherified silica gel for liquid chromatography (10 μm in particle diameter).

Column temperature: A constant temperature of about 25°C.

Mobile phase: Dissolve 1.05 g of disodium hydrogen phosphate dodecahydrate and 0.58 g of potassium dihydrogen phosphate in water to make 1000 mL.

Flow rate: Adjust so that the retention time of ceftributen is about 20 minutes.

Time span of measurement: About 1.6 times as long as the retention time of ceftributen.

System suitability—

Test for required detectability: To 1 mL of the sample solution add the mobile phase to make 20 mL, and use this solution as the solution for system suitability test. Pipet 2 mL of the solution for system suitability test, and add the mobile phase to make exactly 20 mL. Confirm that the peak area of ceftributen obtained with 10 μL of this solution is equivalent to 7 to 13% of that with 10 μL of the solution for system suitability test.

System performance: When the procedure is run with 10 μL of the solution for system suitability test under the above operating conditions, the number of theoretical plates and the symmetry factor of the peak of ceftributen are not less than 10,000 and 0.8 – 1.2, respectively.

System repeatability: When the test is repeated 5 times with 10 μL of the solution for system suitability test under the above operating conditions, the relative standard deviation of the peak area of ceftributen is not more than 1.7%.

Water <2.48> Not less than 8.0% and not more than 13.0% (0.2 g, volumetric titration, direct titration. Use a mixture of pyridine for water determination and ethylene glycol for water determination (5:1) instead of methanol for water determination).

Residue on ignition <2.44> Not more than 0.1% (1 g).

Assay Keep the sample solution and the standard solution at not exceeding 5°C and use within 2 hours after preparation. Weigh accurately an amount of Ceftributen Hydrate and Ceftributen Hydrochloride RS, equivalent to about 10 mg (potency), dissolve each in about 36 mL of 0.1 mol/L phosphate buffer solution for antibiotics (pH 8.0), add exactly 4 mL each of the internal standard solution, shake, and use these solutions as the sample solution and the standard solution, respectively. Perform the test with 5 μL each of the sample solution and standard solution as directed under Liquid Chromatography <2.01> according to the following conditions, and calculate the ratios, Q_T and Q_S , of the peak area of ceftributen to that of the internal standard.

$$\begin{aligned} \text{Amount } [\mu\text{g (potency)}] \text{ of cefprozime (C}_{15}\text{H}_{14}\text{N}_4\text{O}_6\text{S}_2) \\ = M_S \times Q_T / Q_S \times 1000 \end{aligned}$$

M_S : Amount [mg (potency)] of Cefprozime Hydrochloride RS taken

Internal standard solution—A solution of methyl parahydroxybenzoate in acetonitrile (3 in 4000).

Operating conditions—

Detector: An ultraviolet absorption photometer (wavelength: 263 nm).

Column: A stainless steel column 4 mm in inside diameter and 20 cm in length, packed with octadecylsilanized silica gel for liquid chromatography (7 μm in particle diameter).

Column temperature: A constant temperature of about 25°C.

Mobile phase: A mixture of 0.005 mol/L *n*-decyl trimethylammonium bromide TS and acetonitrile (4:1).

Flow rate: Adjust so that the retention time of cefprozime is about 10 minutes.

System suitability—

System performance: Dissolve 5 mg of Cefprozime Hydrate in 20 mL of 0.1 mol/L hydrochloric acid TS, and allow to stand at 40°C for 1 hour. To 4 mL of this solution add 0.1 mol/L phosphate buffer solution for antibiotics (pH 8.0) to make 25 mL. When the procedure is run with 5 μL of this solution under the above operating conditions, trans-isomer of cefprozime and cefprozime are eluted in this order with the resolution between these peaks being not less than 1.5.

System repeatability: When the test is repeated 6 times with 5 μL of the standard solution under the above operating conditions, the relative standard deviation of the ratio of the peak area of cefprozime to that of the internal standard is not more than 1.0%.

Containers and storage Containers—Tight containers.

Storage—Light-resistant, and not exceeding 5°C.

Cefprozime Sodium

セフprozimeナトリウム

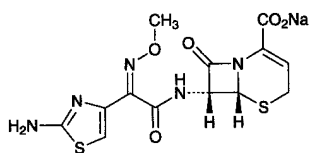

$\text{C}_{13}\text{H}_{12}\text{N}_5\text{NaO}_5\text{S}_2$: 405.38

Monosodium (6*R*,7*R*)-7-[(*Z*)-2-(2-aminothiazol-4-yl)-2-(methoxyimino)acetylamino]-8-oxo-5-thia-1-azabicyclo[4.2.0]oct-2-ene-2-carboxylate [68401-82-1]

Cefprozime Sodium contains not less than 925 μg (potency) and not more than 965 μg (potency) per mg, calculated on the anhydrous basis. The potency of Cefprozime Sodium is expressed as mass (potency) of cefprozime ($\text{C}_{13}\text{H}_{13}\text{N}_5\text{O}_5\text{S}_2$: 383.40).

Description Cefprozime Sodium occurs as a white to light yellow, crystals or crystalline powder.

It is very soluble in water, sparingly soluble in methanol, and practically insoluble in ethanol (95).

Identification (1) Determine the absorption spectrum of a solution of Cefprozime Sodium (1 in 63,000) as directed under Ultraviolet-visible Spectrophotometry <2.24>, and compare the spectrum with the Reference Spectrum: both

spectra exhibit similar intensities of absorption at the same wavelengths.

(2) Determine the infrared absorption spectrum of Cefprozime Sodium as directed in the potassium bromide disk method under Infrared Spectrophotometry <2.25>, and compare the spectrum with the Reference Spectrum: both spectra exhibit similar intensities of absorption at the same wave numbers.

(3) Determine the ^1H spectrum of a solution of Cefprozime Sodium in heavy water for nuclear magnetic resonance spectroscopy (1 in 10) as directed under Nuclear Magnetic Resonance Spectroscopy <2.21>, using sodium 3-trimethylsilylpropionate- d_4 for nuclear magnetic resonance spectroscopy as an internal reference compound: it exhibits a singlet signal A at around δ 4.0 ppm, a multiplet signal B around δ 6.3 ppm, and a singlet signal C at around δ 7.0 ppm. The ratio of integrated intensity of each signal, A:B:C, is about 3:1:1.

(4) Cefprozime Sodium responds to Qualitative Tests <1.09> (1) for sodium salt.

Optical rotation <2.49> $[\alpha]_D^{20}$: +125 – +145° (0.25 g calculated on the anhydrous bases, water, 25 mL, 100 mm).

pH <2.54> Dissolve 1.0 g of Cefprozime Sodium in 10 mL of water: the pH of the solution is between 6.0 and 8.0.

Purity (1) Clarity and color of solution—Dissolve 1.0 g of Cefprozime Sodium in 10 mL of water: the solution is clear. Perform the test with this solution as directed under Method for Color Matching <2.65>: the color is not more colored than Matching Fluid M.

(2) Heavy metals <1.07>—Proceed with 2.0 g of Cefprozime Sodium according to Method 2, and perform the test. Prepare the control solution with 2.0 mL of Standard Lead Solution (not more than 10 ppm).

(3) Arsenic <1.11>—Prepare the test solution with 2.0 g of Cefprozime Sodium according to Method 3, and perform the test (not more than 1 ppm).

(4) Related substances—Dissolve 0.11 g of Cefprozime Sodium in 100 mL of 0.1 mol/L phosphate buffer solution (pH 7.0) and use this solution as the sample solution. Perform the test with 5 μL of the sample solution as directed under Liquid Chromatography <2.01> according to the following conditions, and determine the areas of each peak by the automatic integration method: each peak area other than cefprozime is not more than 0.5% of the peak area of cefprozime, and the total area of peaks other than cefprozime is not more than 1.0% of that of cefprozime.

Operating conditions—

Detector, column, and column temperature: Proceed as directed in the operating conditions in the Assay.

Mobile phase: Dissolve 2.31 g of disodium hydrogenphosphate dodecahydrate and 1.42 g of citric acid monohydrate in 1000 mL of water, adjust to pH 3.6 with diluted phosphoric acid (1 in 10) or dilute sodium hydroxide TS. To 200 mL of this solution add 10 mL of acetonitrile.

Flow rate: Adjust so that the retention time of cefprozime is about 12 minutes.

Time span of measurement: About 5 times as long as the retention time of cefprozime, beginning after the solvent peak.

System suitability—

Test for required detectability: Pipet 1 mL of the sample solution, add 0.1 mol/L phosphate buffer solution (pH 7.0) to make exactly 100 mL, and use this solution as the solution for test for required detectability. Pipet 1 mL of the solution, add 0.1 mol/L phosphate buffer solution (pH 7.0) to

make exactly 10 mL, and confirm that the peak area of ceftizoxime obtained with 5 μ L of this solution is equivalent to 7 to 13% of that with 5 μ L of the solution for test for required detectability.

System performance: Dissolve about 10 mg of Ceftizoxime RS in 100 mL of 0.1 mol/L phosphate buffer solution (pH 7.0) and use this solution as the solution for system suitability test. When the procedure is run with 5 μ L of this solution under the above operating conditions, the number of theoretical plates and the symmetry factor of the peak of ceftizoxime are not less than 4000 and not more than 2.0, respectively.

System repeatability: When the test is repeated 6 times with 5 μ L of the solution for system suitability test under the above operating conditions, the relative standard deviation of the peak areas of ceftizoxime is not more than 2.0%.

Water <2.48> Not more than 8.5% (0.4 g, volumetric titration, direct titration).

Assay Weigh accurately an amount of Ceftizoxime Sodium and Ceftizoxime RS, equivalent to about 25 mg (potency), dissolve each in 0.1 mol/L phosphate buffer solution (pH 7.0), add exactly 20 mL of the internal standard solution, then add 0.1 mol/L phosphate buffer solution (pH 7.0) to make 50 mL, and use these solutions as the sample solution and the standard solution, respectively. Perform the test with 5 μ L each of the sample solution and standard solution as directed under Liquid Chromatography <2.01> according to the following conditions, and calculate the ratios, Q_T and Q_S , of the peak area of ceftizoxime to that of the internal standard.

$$\begin{aligned} \text{Amount } [\mu\text{g (potency)}] \text{ of ceftizoxime (C}_{13}\text{H}_{13}\text{N}_5\text{O}_5\text{S}_2) \\ = M_S \times Q_T / Q_S \times 1000 \end{aligned}$$

M_S : Amount [mg (potency)] of Ceftizoxime RS taken

Internal standard solution—A solution of 3-hydroxybenzoic acid in 0.1 mol/L phosphate buffer solution (pH 7.0) (3 in 400).

Operating conditions—

Detector: An ultraviolet absorption photometer (wavelength: 254 nm).

Column: A stainless steel column 4.6 mm in inside diameter and 25 cm in length, packed with octadecylsilanized silica gel for liquid chromatography (10 μ m in particle diameter).

Column temperature: A constant temperature of about 35°C.

Mobile phase: Dissolve 2.31 g of disodium hydrogen phosphate dodecahydrate and 1.42 g of citric acid monohydrate in 1000 mL of water, and adjust to pH 3.6 with diluted phosphoric acid (1 in 10) or dilute sodium hydroxide TS. To 450 mL of this solution add 50 mL of acetonitrile.

Flow rate: Adjust so that the retention time of ceftizoxime is about 4 minutes.

System suitability—

System performance: When the procedure is run with 5 μ L of the standard solution under the above operating conditions, ceftizoxime and the internal standard are eluted in this order with the resolution between these peaks being not less than 7.0 and the symmetry factor of each peak is not more than 1.5.

System repeatability: When the test is repeated 6 times with 5 μ L of the standard solution under the above operating conditions, the relative standard deviation of the ratio of the peak area of ceftizoxime to that of the internal standard is not more than 1.0%.

Containers and storage Containers—Tight containers.

Storage—Light-resistant.

Ceftriaxone Sodium Hydrate

セフトリアキソンナトリウム水和物

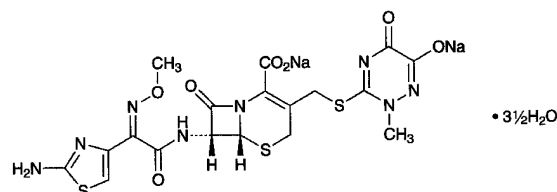

$\text{C}_{18}\text{H}_{16}\text{N}_8\text{Na}_2\text{O}_7\text{S}_3 \cdot 3\frac{1}{2}\text{H}_2\text{O}$: 661.60

Disodium (6R,7R)-7-[(Z)-2-(2-aminothiazol-4-yl)-2-(methoxyimino)acetylamino]-3-(6-hydroxy-2-methyl-5-oxo-2,5-dihydro-1,2,4-triazin-3-ylsulfanylmethyl)-8-oxo-5-thia-1-azabicyclo[4.2.0]oct-2-ene-2-carboxylate hemiheptahydrate
[104376-79-6]

Ceftriaxone Sodium Hydrate contains not less than 905 μ g (potency) and not more than 935 μ g (potency) per mg, calculated on the anhydrous basis. The potency of Ceftriaxone Sodium Hydrate is expressed as mass (potency) of ceftriaxone ($\text{C}_{18}\text{H}_{18}\text{N}_8\text{O}_7\text{S}_3$: 554.58).

Description Ceftriaxone Sodium Hydrate occurs as a white to yellow-white crystalline powder.

It is freely soluble in water and in dimethylsulfoxide, sparingly soluble in methanol, very slightly soluble in ethanol (99.5), and practically insoluble in acetonitrile.

Identification (1) Determine the absorption spectrum of a solution of Ceftriaxone Sodium Hydrate (1 in 100,000) as directed under Ultraviolet-visible Spectrophotometry <2.24>, and compare the spectrum with the Reference Spectrum or the spectrum of a solution of Ceftriaxone Sodium RS prepared in the same manner as the sample solution: both spectra exhibit similar intensities of absorption at the same wavelengths.

(2) Determine the ^1H spectrum of a solution of Ceftriaxone Sodium Hydrate in deuterated dimethylsulfoxide for nuclear magnetic resonance spectroscopy (1 in 10) as directed under Nuclear Magnetic Resonance Spectroscopy <2.21>, using tetramethylsilane for nuclear magnetic resonance spectroscopy as an internal reference compound: it exhibits singlet signals, A, B, C and D, at around δ 3.5 ppm, at around δ 3.8 ppm, at around δ 6.7 ppm and at around δ 7.2 ppm, respectively. The ratio of integrated intensity of each signal, A: B: C: D, is about 3:3:1:2. When the signal at around δ 3.5 ppm overlaps with the signal of water, perform the measurement in the probe kept at about 50°C.

(3) Ceftriaxone Sodium Hydrate responds to Qualitative Tests <1.09> (1) for sodium salt.

Optical rotation <2.49> $[\alpha]_D^{20}$: $-153 - -170^\circ$ (50 mg calculated on the anhydrous basis, water, 2.5 mL, 20 mm).

pH <2.54> Dissolve 0.6 g of Ceftriaxone Sodium Hydrate in 5 mL of water: the pH of the solution is between 6.0 and 8.0.

Purity (1) Clarity and color of solution—Dissolve 0.6 g of Ceftriaxone Sodium Hydrate in 5 mL of water: the solution is clear and light yellow.

(2) Heavy metals <1.07>—Proceed with 1.0 g of Ceftriaxone Sodium Hydrate according to Method 2, and

perform the test. Prepare the control solution with 2.0 mL of Standard Lead Solution (not more than 20 ppm).

(3) Arsenic <1.11>—Prepare the test solution with 1.0 g of Ceftriaxone Sodium Hydrate according to Method 3, and perform the test (not more than 2 ppm).

(4) Related substances 1—Dissolve 20 mg of Ceftriaxone Sodium Hydrate in 10 mL of the mobile phase, and use this solution as the sample solution. Pipet 1 mL of the sample solution, add a mixture of water and acetonitrile for liquid chromatography (11:9) to make exactly 100 mL, and use this solution as the standard solution. Perform the test with exactly 10 μ L each of the sample solution and standard solution as directed under Liquid Chromatography <2.01> according to the following conditions, and determine each peak area by the automatic integration method: the peak areas of the impurity 1 having the relative retention time of about 0.5 and the impurity 2 having the relative retention time of about 1.3 to ceftriaxone obtained from the sample solution are not larger than the peak area of ceftriaxone from the standard solution. For the areas of the peaks, the impurity 1 and the impurity 2, multiply their correction factors 0.9 and 1.2, respectively.

Operating conditions—

Detector: An ultraviolet absorption photometer (wavelength: 254 nm).

Column: A stainless steel column 4.6 mm in inside diameter and 25 cm in length, packed with octadecylsilanized silica gel for liquid chromatography (10 μ m in particle diameter).

Column temperature: A constant temperature of about 25°C.

Mobile phase: Dissolve 5.796 g of anhydrous disodium hydrogen phosphate and 3.522 g of potassium dihydrogen phosphate in water to make exactly 1000 mL, and use this solution as the solution A. Separately, dissolve 20.256 g of citric acid monohydrate and 7.840 g of sodium hydroxide in water to make exactly 1000 mL, and use this solution as the solution B. Dissolve 4.00 g of tetra-*n*-heptylammonium bromide in 450 mL of acetonitrile for liquid chromatography, add 55 mL of the solution A, 5 mL of the solution B and 490 mL of water.

Flow rate: Adjust so that the retention time of ceftriaxone is about 7 minutes.

Time span of measurement: About 2 times as long as the retention time of ceftriaxone.

System suitability—

Test for required detectability: To 5 mL of the sample solution, add a mixture of water and acetonitrile for liquid chromatography (11:9) to make 200 mL, and use this solution as the solution for system suitability test. Pipet 1 mL of the solution for system suitability test, and add a mixture of water and acetonitrile for liquid chromatography (11:9) to make exactly 100 mL. Confirm that the peak area of ceftriaxone obtained with 10 μ L of this solution is equivalent to 0.9 to 1.1% of that with 10 μ L of the solution for system suitability test.

System performance: Dissolve 10 mg of Ceftriaxone Sodium Hydrate in a mixture of water and acetonitrile for liquid chromatography (11:9) to make 5 mL, add 5 mL of a solution of diethyl terephthalate in a mixture of water and acetonitrile for liquid chromatography (11:9) (9 in 5000), and add a mixture of water and acetonitrile for liquid chromatography (11:9) to make 200 mL. When the procedure is run with 10 μ L of this solution under the above operating conditions, ceftriaxone and diethyl terephthalate are eluted in this order, with the resolution between these peaks being not less than 6.

System repeatability: When the test is repeated 6 times

with 10 μ L of the solution for system suitability test under the above operating conditions, the relative standard deviation of the peak area of ceftriaxone is not more than 1.0%.

(5) Related substances 2—Dissolve 10 mg of Ceftriaxone Sodium Hydrate in 10 mL of the mobile phase, and use this solution as the sample solution. Pipet 1 mL of the sample solution, add a mixture of acetonitrile for liquid chromatography and water (23:11) to make exactly 100 mL, and use this solution as standard solution. Perform the test with exactly 10 μ L each of the sample solution and standard solution as directed under Liquid Chromatography <2.01> according to the following conditions, and determine each peak area by the automatic integration method: the each peak area of the impurities which appear after the peak of ceftriaxone obtained from the sample solution is not larger than the peak area of ceftriaxone from the standard solution, and the total peak area of these impurities is not larger than 2.5 times of the peak area from the standard solution.

Operating conditions—

Detector: An ultraviolet absorption photometer (wavelength: 254 nm).

Column: A stainless steel column 4.6 mm in inside diameter and 25 cm in length, packed with octadecylsilanized silica gel for liquid chromatography (10 μ m in particle diameter).

Column temperature: A constant temperature of about 25°C.

Mobile phase: Dissolve 5.796 g of anhydrous disodium hydrogen phosphate and 3.522 g of potassium dihydrogen phosphate in water to make exactly 1000 mL, and use this solution as the solution A. Separately, dissolve 20.256 g of citric acid monohydrate and 7.840 g of sodium hydroxide in water to make exactly 1000 mL, and use this solution as the solution B. Dissolve 4.00 g of tetra-*n*-heptylammonium bromide in 450 mL of acetonitrile for liquid chromatography, and add 55 mL of the solution A, 5 mL of the solution B, 490 mL of water and 700 mL of acetonitrile for liquid chromatography.

Flow rate: Adjust so that the retention time of ceftriaxone is about 3 minutes.

Time span of measurement: About 10 times as long as the retention time of ceftriaxone.

System suitability—

Test for required detectability: Measure 5 mL of the sample solution, add a mixture of acetonitrile for liquid chromatography and water (23:11) to make 100 mL, and use this solution as the solution for system suitability test. Measure exactly 1 mL of the solution for system suitability test, and add a mixture of acetonitrile for liquid chromatography and water (23:11) to make exactly 100 mL. Confirm that the peak area of ceftriaxone obtained with 10 μ L of this solution is equivalent to 0.9 to 1.1% of that with 10 μ L of the solution for system suitability test.

System performance: Dissolve 10 mg of Ceftriaxone Sodium Hydrate in a mixture of acetonitrile for liquid chromatography and water (23:11) to make 5 mL, add 5 mL of a solution of diethyl terephthalate in a mixture of water and acetonitrile for liquid chromatography (11:9) (9 in 5000), and add a mixture of acetonitrile for liquid chromatography and water (23:11) to make 200 mL. When the procedure is run with 10 μ L of this solution under the above operating conditions, ceftriaxone and diethyl terephthalate are eluted in this order with the resolution between these peaks being not less than 3.

System repeatability: When the test is repeated 6 times with 10 μ L of the solution for system suitability test under the above operating conditions, the relative standard deviation of the peak area of ceftriaxone is not more than 1.0%.

Water <2.48> Not less than 8.0% and not more than 11.0% (0.15 g, volumetric titration, direct titration).

Assay Weigh accurately an amount of Ceftriaxone Sodium Hydrate and Ceftriaxone Sodium RS, equivalent to about 0.1 g (potency), dissolve each in a mixture of water and acetonitrile for liquid chromatography (11:9) to make exactly 50 mL. Pipet 5 mL of each solution, add exactly 5 mL of the internal standard solution and a mixture of water and acetonitrile for liquid chromatography (11:9) to make 200 mL, and use these solutions as the sample solution and the standard solution, respectively. Perform the test with 10 μ L each of the sample solution and standard solution as directed under Liquid Chromatography <2.01> according to the following conditions, and calculate the ratios, Q_T and Q_S , of the peak area of ceftriaxone to that of the internal standard.

$$\text{Amount } [\mu\text{g (potency)}] \text{ of ceftriaxone (C}_{18}\text{H}_{18}\text{N}_8\text{O}_7\text{S}_3) \\ = M_S \times Q_T / Q_S \times 1000$$

M_S : Amount [mg (potency)] of Ceftriaxone Sodium RS taken

Internal standard solution—A solution of diethyl terephthalate in a mixture of water and acetonitrile for liquid chromatography (11:9) (9 in 5000).

Operating conditions—

Detector: An ultraviolet absorption photometer (wavelength: 254 nm).

Column: A stainless steel column 4.6 mm in inside diameter and 25 cm in length, packed with octadecylsilanized silica gel for liquid chromatography (10 μ m in particle diameter).

Column temperature: A constant temperature of about 25°C.

Mobile phase: Dissolve 5.796 g of anhydrous disodium hydrogen phosphate and 3.522 g of potassium dihydrogen phosphate in water to make exactly 1000 mL, and use this solution as solution A. Dissolve 20.256 g of citric acid monohydrate and 7.840 g of sodium hydroxide in water to make exactly 1000 mL, and use this solution as solution B. Dissolve 4.00 g of tetra-*n*-heptylammonium bromide in 450 mL of acetonitrile for liquid chromatography, and add 490 mL of water, 55 mL of solution A, and 5 mL of solution B.

Flow rate: Adjust so that the retention time of ceftriaxone is about 7 minutes.

System suitability—

System performance: When the procedure is run with 10 μ L of the standard solution under the above operating conditions, ceftriaxone and the internal standard are eluted in this order with the resolution between these peaks being not less than 6.

System repeatability: When the test is repeated 6 times with 10 μ L of the standard solution under the above operating conditions, the relative standard deviation of the ratios of the peak area of ceftriaxone to that of the internal standard is not more than 1.0%.

Containers and storage Containers—Tight containers.

Storage—Light-resistant.

Cefuroxime Axetil

セフロキシム アキセチル

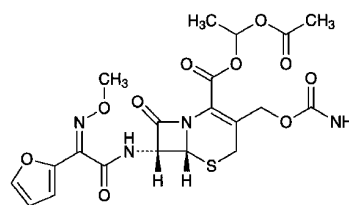

$\text{C}_{20}\text{H}_{22}\text{N}_4\text{O}_{10}\text{S}$: 510.47

(1*RS*)-1-Acetoxyethyl (6*R*,7*R*)-3-carbamoyloxymethyl-7-[(*Z*)-2-furan-2-yl-2-(methoxyimino)acetyl amino]-8-oxo-5-thia-1-azabicyclo[4.2.0]oct-2-ene-2-carboxylate [64544-07-6]

Cefuroxime Axetil contains not less than 800 μ g (potency) and not more than 850 μ g (potency) per mg, calculated on the anhydrous and acetone-free basis. The potency of Cefuroxime Axetil is expressed as mass (potency) of cefuroxime ($\text{C}_{16}\text{H}_{16}\text{N}_4\text{O}_8\text{S}$: 424.39).

Description Cefuroxime Axetil occurs as white to yellow-white non-crystalline powder.

It is freely soluble in dimethylsulfoxide, soluble in methanol, sparingly soluble in ethanol (95), and very slightly soluble in water.

Identification (1) Determine the absorption spectrum of a solution of Cefuroxime Axetil in methanol (3 in 200,000) as directed under Ultraviolet-visible Spectrophotometry <2.24>, and compare the spectrum with the Reference Spectrum or the spectrum of a solution of Cefuroxime Axetil RS prepared in the same manner as the sample solution: both spectra exhibit similar intensities of absorption at the same wavelengths.

(2) Determine the infrared absorption spectrum of Cefuroxime Axetil as directed in the potassium bromide disk method under Infrared Spectrophotometry <2.25>, and compare the spectrum with the Reference Spectrum or the spectrum of Cefuroxime Axetil RS: both spectra exhibit similar intensities of absorption at the same wave numbers.

(3) Determine the ^1H spectrum of a solution of Cefuroxime Axetil in deuterated dimethylsulfoxide for nuclear magnetic resonance spectroscopy (1 in 20) as directed under Nuclear Magnetic Resonance Spectroscopy <2.21>, using tetramethylsilane for nuclear magnetic resonance spectroscopy as an internal reference compound: it exhibits a doublet signal or a pair of doublet signals A at around δ 1.5 ppm, a pair of singlet signals B at around δ 2.1 ppm, and a singlet signal C at around δ 3.9 ppm. The ratio of the integrated intensity of each signal, A:B:C, is about 1:1:1.

Optical rotation <2.49> $[\alpha]_{\text{D}}^{20}$: +41 – +47° (0.5 g, methanol, 50 mL, 100 mm).

Purity (1) Heavy metals <1.07>—Proceed with 2.0 g of Cefuroxime Axetil according to Method 2, and perform the test. Prepare the control solution with 2.0 mL of Standard Lead Solution (not more than 10 ppm).

(2) Related substances—Dissolve 25 mg of Cefuroxime Axetil in 4 mL of methanol, add a solution of ammonium dihydrogenphosphate (23 in 1000) to make 10 mL, and use this solution as the sample solution. Pipet 1 mL of the sample solution, add 40 mL of methanol and a solution of ammonium dihydrogenphosphate (23 in 1000) to make exactly

100 mL, and use this solution as the standard solution. Perform the test with exactly 2 μ L each of the sample solution and standard solution as directed under Liquid Chromatography <2.01> according to the following conditions, and determine each peak area by the automatic integration method: the area of the peak other than cefuroxime axetil obtained from the sample solution is not larger than 1.5 times the total area of the two peaks of cefuroxime axetil from the standard solution, and the total area of the peaks other than cefuroxime axetil from the sample solution is not larger than 4 times the total area of the two peaks of cefuroxime axetil from the standard solution.

Operating conditions—

Detector, column, column temperature, mobile phase, and flow rate: Proceed as directed in the operating conditions in the Assay.

Time span of measurement: About 3 times as long as the retention time of the peak having the larger retention time of the two peaks of cefuroxime axetil, beginning after the solvent peak.

System suitability—

Test for required detectability: Pipet 1 mL of the standard solution, and add 4 mL of methanol and a solution of ammonium dihydrogenphosphate (23 in 1000) to make exactly 10 mL. Confirm that the total area of the two peaks of cefuroxime axetil obtained with 2 μ L of this solution is equivalent to 7 to 13% of that with 2 μ L of the standard solution.

System performance: When the procedure is run with 2 μ L of the standard solution under the above operating conditions, the resolution between the two peaks of cefuroxime axetil is not less than 1.5.

System repeatability: When the test is repeated 6 times with 2 μ L of the standard solution under the above operating conditions, the relative standard deviation of the total area of the two peaks of cefuroxime axetil is not more than 2.0%.

(3) Acetone—Weigh accurately about 1 g of Cefuroxime Axetil, add exactly 0.2 mL of the internal standard solution and dimethylsulfoxide to make 10 mL, and use this solution as the sample solution. Separately, weigh accurately about 0.5 g of acetone, and add dimethylsulfoxide to make exactly 100 mL. Pipet 0.2 mL of this solution, add exactly 0.2 mL of the internal standard solution and dimethylsulfoxide to make 10 mL, and use this solution as the standard solution. Perform the test with 1 μ L each of the sample solution and standard solution as directed under Gas Chromatography <2.02> according to the following conditions, and calculate the ratios, Q_T and Q_S , of the peak area of acetone to that of the internal standard: the amount of acetone is not more than 1.3%.

$$\text{Amount (\%)} \text{ of acetone} = M_S/M_T \times Q_T/Q_S \times 1/5$$

M_S : Amount (g) of acetone taken

M_T : Amount (g) of Cefuroxime Axetil taken

Internal standard solution—A solution of 1-propanol in dimethylsulfoxide (1 in 200).

Operating conditions—

Detector: A hydrogen flame-ionization detector.

Column: A glass column 3 mm in inside diameter and 2 m in length, packed with siliceous earth for gas chromatography coated with a mixture of polyethylene glycol 600 for gas chromatography and polyethylene glycol 1500 for gas chromatography (1:1) in the ratio of 20% (125 – 150 μ m in particle diameter).

Column temperature: A constant temperature of about 90°C.

Temperature of injection port: A constant temperature of about 115°C.

Carrier gas: Nitrogen.

Flow rate: Adjust so that the retention time of the internal standard is about 4 minutes.

System suitability—

System performance: When the procedure is run with 1 μ L of the standard solution under the above operating conditions, acetone and the internal standard are eluted in this order with the resolution between these peaks being not less than 5.

System repeatability: When the test is repeated 6 times with 1 μ L of the standard solution under the above operating conditions, the relative standard deviation of the ratio of the peak area of acetone to that of the internal standard is not more than 5.0%.

Water <2.48> Not more than 2.0% (0.4 g, volumetric titration, direct titration).

Residue on ignition <2.44> Not more than 0.2% (0.5 g).

Isomer ratio Perform the test with 10 μ L of the sample solution obtained in the Assay as directed under Liquid Chromatography <2.01> according to the following conditions, and determine the area, A_a , of the peak having the smaller retention time and the area, A_b , of the peak having the bigger retention time of the two peaks of cefuroxime axetil: $A_b/(A_a + A_b)$ is between 0.48 and 0.55.

Operating conditions—

Detector, column, column temperature, mobile phase, and flow rate: Proceed as directed in the operating conditions in the Assay.

System suitability—

System performance, and system repeatability: Proceed as directed in the system suitability in the Assay.

Assay Weigh accurately an amount of Cefuroxime Axetil and Cefuroxime Axetil RS, equivalent to about 50 mg (potency), and dissolve each in methanol to make exactly 50 mL. Pipet 10 mL each of these solutions, add exactly 5 mL of the internal standard solution, 5 mL of methanol and a solution of ammonium dihydrogen phosphate (23 in 1000) to make 50 mL, and use these solutions as the sample solution and standard solution. Perform the test with 10 μ L each of the sample solution and standard solution as directed under Liquid Chromatography <2.01> according to the following conditions, and calculate the ratios, Q_T and Q_S , of the sum area of the two peaks of cefuroxime axetil to the peak area of the internal standard.

$$\begin{aligned} &\text{Amount } [\mu\text{g (potency)}] \text{ of cefuroxime (C}_{16}\text{H}_{16}\text{N}_4\text{O}_8\text{S)} \\ &= M_S \times Q_T/Q_S \times 1000 \end{aligned}$$

M_S : Amount [mg (potency)] of Cefuroxime Axetil RS taken

Internal standard solution—A solution of acetanilide in methanol (27 in 5000).

Operating conditions—

Detector: An ultraviolet absorption photometer (wavelength: 278 nm).

Column: A stainless steel column 4.6 mm in inside diameter and 20 cm in length, packed with trimethylsilanized silica gel for liquid chromatography (5 μ m in particle diameter).

Column temperature: A constant temperature of about 25°C.

Mobile phase: A mixture of a solution of ammonium dihydrogen phosphate (23 in 1000) and methanol (5:3).

Flow rate: Adjust so that the retention time of the peak

having the smaller retention time of the two peaks of cefuroxime axetil is about 8 minutes.

System suitability—

System performance: When the procedure is run with 10 μL of the standard solution under the above operating conditions, the internal standard and cefuroxime axetil are eluted in this order with the resolution between the two peaks of cefuroxime axetil being not less than 1.5.

System repeatability: When the test is repeated 6 times with 10 μL of the standard solution under the above operating conditions, the relative standard deviation of the ratios of the sum area of the two peaks of cefuroxime axetil to the peak area of the internal standard is not more than 1.0%.

Containers and storage Containers—Tight containers.

Storage—Light-resistant.

Celecoxib

セレコキシブ

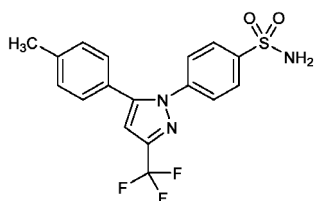

$\text{C}_{17}\text{H}_{14}\text{F}_3\text{N}_3\text{O}_2\text{S}$: 381.37

4-[5-(4-Methylphenyl)-3-(trifluoromethyl)-1H-pyrazol-1-yl]benzenesulfonamide
[169590-42-5]

Celecoxib contains not less than 98.0% and not more than 102.0% of celecoxib ($\text{C}_{17}\text{H}_{14}\text{F}_3\text{N}_3\text{O}_2\text{S}$), calculated on the anhydrous basis.

Description Celecoxib occurs as a white, powder or crystalline powder.

It is freely soluble in methanol, soluble in ethanol (99.5), and practically insoluble in water.

Melting point: 161 – 164°C

Celecoxib shows crystal polymorphism.

Identification (1) Determine the absorption spectrum of a solution of Celecoxib in methanol (1 in 100,000) as directed under Ultraviolet-visible Spectrophotometry <2.24>, and compare the spectrum with the Reference Spectrum or the spectrum of a solution of Celecoxib RS prepared in the same manner as the sample solution: both spectra exhibit similar intensities of absorption at the same wavelengths.

(2) Determine the infrared absorption spectrum of Celecoxib, as directed in the potassium bromide disk method under Infrared Spectrophotometry <2.25>, and compare the spectrum with the Reference Spectrum or the spectrum of Celecoxib RS: both spectra exhibit similar intensities of absorption at the same wave numbers.

Purity (1) Heavy metals <1.07>—Proceed with 1.0 g of Celecoxib according to Method 4, and perform the test. Prepare the control solution with 2.0 mL of Standard Lead Solution (not more than 20 ppm).

(2) Related substances—Use the sample solution obtained in the Assay as the sample solution. Separately, weigh accurately about 50 mg of Celecoxib RS, dissolve in a mixture of methanol and water (3:1) to make exactly 100 mL.

Pipet 1 mL of this solution, add a mixture of methanol and water (3:1) to make exactly 100 mL, and use this solution as the standard solution. Perform the test with exactly 25 μL each of the sample solution and standard solution as directed under Liquid Chromatography <2.01> according to the following conditions. Determine each peak area, A_T , in the sample solution and the peak area of celecoxib, A_S , in the standard solution by the automatic integration method, and calculate the amount of the related substances by the following equation: the amount of related substance A having the relative retention time of about 0.94 to celecoxib is not more than 0.4%, and each amount of the related substances other than related substance A is not more than 0.10%. Furthermore, the total amount of the related substances is not more than 0.5%.

$$\text{Amount (\% of related substance)} = M_S/M_T \times A_T/A_S$$

M_S : Amount (mg) of Celecoxib RS taken

M_T : Amount (mg) of Celecoxib taken

Operating conditions—

Detector, column, column temperature, mobile phase, and flow rate: Proceed as directed in the operating conditions in the Assay.

Time span of measurement: About 1.5 times as long as the retention time of celecoxib, beginning after the solvent peak.

System suitability—

System performance and system repeatability: Proceed as directed in the system suitability in the Assay.

Test for required detectability: Pipet 5 mL of the standard solution, and add a mixture of methanol and water (3:1) to make exactly 100 mL. Confirm that the peak area of celecoxib obtained with 25 μL of this solution is equivalent to 3.5 to 6.5% of that with 25 μL of the standard solution.

Water <2.48> Not more than 0.5% (0.3 g, volumetric titration, direct titration).

Residue on ignition <2.44> Not more than 0.2% (1.0 g, platinum crucible).

Assay Weigh accurately about 50 mg each of Celecoxib and Celecoxib RS, and dissolve each in a mixture of methanol and water (3:1) to make exactly 100 mL, and use these solutions as the sample solution and the standard solution, respectively. Perform the test with exactly 25 μL each of the sample solution and standard solution as directed under Liquid Chromatography <2.01> according to the following conditions, and determine the peak areas, A_T and A_S , of celecoxib in each solution.

$$\begin{aligned} \text{Amount (mg) of celecoxib (C}_{17}\text{H}_{14}\text{F}_3\text{N}_3\text{O}_2\text{S)} \\ = M_S \times A_T/A_S \end{aligned}$$

M_S : Amount (mg) of Celecoxib RS taken

Operating conditions—

Detector: An ultraviolet absorption photometer (wavelength: 215 nm).

Column: A stainless steel column 4.6 mm in inside diameter and 25 cm in length, packed with phenylated silica gel for liquid chromatography (5 μm in particle diameter).

Column temperature: A constant temperature of about 60°C.

Mobile phase: Adjust 0.02 mol/L potassium dihydrogen phosphate TS to pH 3.0 with phosphoric acid. To 600 mL of this solution add 300 mL of methanol for liquid chromatography and 100 mL of acetonitrile for liquid chromatography.

Flow rate: Adjust so that the retention time of celecoxib is about 22 minutes.

System suitability—

System performance: When the procedure is run with 25 μL of the standard solution under the above operating conditions, the number of theoretical plates and the symmetry factor of the peak of celecoxib are not less than 6000 and not more than 2.0, respectively.

System repeatability: When the test is repeated 6 times with 25 μL of the standard solution under the above operating conditions, the relative standard deviation of the peak area of celecoxib is not more than 1.0%.

Containers and storage Containers—Well-closed containers.

Others

Related substance A:

4-[5-(3-Methylphenyl)-3-(trifluoromethyl)-1*H*-pyrazol-1-yl]benzenesulfonamide

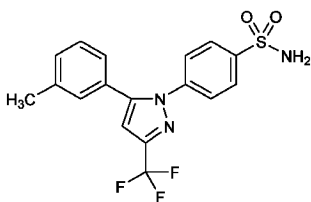
**Cellacefate****Cellulose Acetate Phthalate**

セラセフェート

[9004-38-0]

This monograph is harmonized with the European Pharmacopoeia and the U.S. Pharmacopoeia.

The parts of the text that are not harmonized are marked with symbols (◆ ◆).

Information on the harmonization with the European Pharmacopoeia and the U.S. Pharmacopoeia is available on the website of the Pharmaceuticals and Medical Devices Agency.

Cellacefate is a reaction product of phthalic anhydride and partially acetylated cellulose.

It contains not less than 21.5% and not more than 26.0% of acetyl group ($-\text{COCH}_3$; 43.04), and not less than 30.0% and not more than 36.0% of carboxybenzoyl group ($-\text{COC}_6\text{H}_4\text{COOH}$; 149.12), calculated on the anhydrous and free acid-free basis.

◆**Description** Cellacefate occurs as a white, powder or grain.

It is freely soluble in acetone, and practically insoluble in water and in ethanol (99.5).◆

Identification Determine the infrared absorption spectrum of Cellacefate as directed in the potassium bromide disk method under Infrared Spectrophotometry <2.25>, and compare the spectrum with the Reference Spectrum or the spectrum of Cellacefate for Identification RS: both spectra exhibit similar intensities of absorption at the same wave numbers.

Viscosity <2.53> Weigh accurately a quantity of Cellacefate, equivalent to 15 g calculated on the anhydrous basis, dissolve in 85 g of a mixture of acetone and water (249: 1 in mass), and use this solution as the sample solution. Perform

the test with the sample solution at $25 \pm 0.2^\circ\text{C}$ as directed in Method 1 to obtain the kinematic viscosity ν . Separately, determine the density, ρ , of the sample solution as directed under Determination of Specific Gravity and Density <2.56>, and calculate the viscosity of the sample solution, η , as $\eta = \rho\nu$: not less than 45 $\text{mPa}\cdot\text{s}$ and not more than 90 $\text{mPa}\cdot\text{s}$.

Purity (1) ◆Heavy metals <1.07>—Proceed with 2.0 g of Cellacefate according to Method 2, and perform the test. Prepare the control solution with 2.0 mL of Standard Lead Solution (not more than 10 ppm).◆

(2) Free acids—Weigh accurately about 3 g of Cellacefate, put in a glass-stoppered conical flask, add 100 mL of diluted methanol (1 in 2), stopper tightly, and filter after shaking for 2 hours. Wash both the flask and residue with two 10-mL portions each of diluted methanol (1 in 2), combine the washes to the filtrate, and titrate <2.50> with 0.1 mol/L sodium hydroxide VS (indicator: 2–3 drops of phenolphthalein TS). Perform the blank determination with 120 mL of diluted methanol (1 in 2), and make any necessary correction.

$$\text{Amount (\% of free acids)} = 0.8306A/M$$

A: Amount (mL) of 0.1 mol/L sodium hydroxide VS consumed

M: Amount (g) of Cellacefate taken, calculated on the anhydrous basis

The amount of free acids is not more than 3.0%, calculated as phthalic acid ($\text{C}_8\text{H}_6\text{O}_4$; 166.13).

Water <2.48> Not more than 5.0% (0.5 g, volumetric titration, direct titration, using a mixture of ethanol (99.5) and dichloromethane (3:2) instead of methanol for water determination).

Residue on ignition <2.44> Not more than 0.1% (1 g).

Assay (1) Carboxybenzoyl group—Weigh accurately about 1 g of Cellacefate, dissolve in 50 mL of a mixture of ethanol (95) and acetone (3:2), and titrate <2.50> with 0.1 mol/L sodium hydroxide VS (indicator: 2–3 drops of phenolphthalein TS). Perform a blank determination in the same manner, and make any necessary correction.

Content (%) of carboxybenzoyl group ($\text{C}_8\text{H}_5\text{O}_3$)

$$= \frac{1.491 \times A - (1.795 \times B)}{M} \times 100$$

A: Amount (mL) of 0.1 mol/L sodium hydroxide VS consumed

B: Amount (%) of free acids obtained in the Purity (2)

M: Amount (g) of Cellacefate taken, calculated on the anhydrous basis

(2) Acetyl group—Weigh accurately about 0.1 g of Cellacefate, put in a glass-stoppered conical flask, add exactly 25 mL of 0.1 mol/L sodium hydroxide VS, and boil for 30 minutes under a reflux condenser. After cooling, add 2–3 drops of phenolphthalein TS, and titrate <2.50> the excess of sodium hydroxide with 0.1 mol/L hydrochloric acid VS. Perform a blank determination in the same manner.

Content (%) of free acids and bound acetyl group ($\text{C}_2\text{H}_3\text{O}$)

$$= 0.4305A/M$$

A: Amount (mL) of 0.1 mol/L sodium hydroxide VS consumed, corrected by the blank determination

M: Amount (g) of Cellacefate taken, calculated on the anhydrous basis

Content (%) of acetyl group (C₂H₃O)
 $= 100 \times (P - 0.5182B)/(100 - B) - 0.5772C$

B: Amount (%) of free acids obtained in the Purity (2)

C: Content (%) of carboxybenzoyl group

P: Content (%) of free acids and bound acetyl group (C₂H₃O)

◆**Containers and storage** Containers—Tight containers.◆

Microcrystalline Cellulose

結晶セルロース

[9004-34-6, cellulose]

This monograph is harmonized with the European Pharmacopoeia and the U.S. Pharmacopoeia.

The corresponding part of the attributes/provisions which are agreed as non-harmonized within the scope of the harmonization is marked with symbols (◆ ◆), and the corresponding parts which are agreed as the JP local requirement other than the scope of the harmonization are marked with symbols (◇ ◇).

Information on the harmonization with the European Pharmacopoeia and the U.S. Pharmacopoeia is available on the website of the Pharmaceuticals and Medical Devices Agency.

Microcrystalline Cellulose is purified, partially depolymerized α-cellulose, obtained as a pulp from fibrous plant material, with mineral acids.

The label indicates the ◇mean degree of polymerization, loss on drying,◇ and bulk density values with a range.

◆**Description** Microcrystalline Cellulose occurs as a white crystalline powder having fluidity.

It is practically insoluble in water, in ethanol (95) and in diethyl ether.

It swells with sodium hydroxide TS on heating.◆

Identification (1) Dissolve 20 g of zinc chloride and 6.5 g of potassium iodide in 10.5 mL of water, add 0.5 g of iodine, and shake for 15 minutes. Place about 10 mg of Microcrystalline Cellulose on a watch glass, and disperse in 2 mL of this solution: the substance develops a blue-violet color.

(2) Determine the infrared absorption spectrum of Microcrystalline Cellulose as directed in the ATR method under Infrared Spectrophotometry <2.25>, and compare the spectrum with the spectrum of Microcrystalline Cellulose for Identification RS: both spectra exhibit similar intensities of absorption at the same wave numbers. If there are absorptions between 800 cm⁻¹ and 825 cm⁻¹, and between 950 cm⁻¹ and 1000 cm⁻¹, disregard the absorptions.

(3) Transfer about 1.3 g of Microcrystalline Cellulose, accurately weighed, to a 125-mL conical flask, and add exactly 25 mL each of water and 1 mol/L cupriethylenediamine TS. Immediately purge the solution with nitrogen, insert the stopper, and shake on a suitable mechanical shaker to dissolve. Perform the test with a suitable amount of this solution, taken exactly, according to Method 1 under Viscosity Determination <2.53> using a capillary viscometer having the viscosity constant (*K*) of approximately 0.03, at 25 ± 0.1°C, and determine the kinematic viscosity, *v*. Separately, perform the test with a mixture of exactly 25 mL each of water and 1 mol/L cupriethylenediamine TS in the same

manner as above, using a capillary viscometer having *K* of approximately 0.01, and determine the kinematic viscosity, *v*₀.

Calculate the relative viscosity, *η*_{rel}, of Microcrystalline Cellulose by the following formula:

$$\eta_{\text{rel}} = v/v_0$$

Obtain the product, [*η*]C, of intrinsic viscosity [*η*](mL/g) and concentration *C* (g/100 mL) from the value *η*_{rel} of the table. When calculate the degree of polymerization, *P*, by the following formula, *P* is not more than 350 ◇and within the labeled range.◇

$$P = 95[\eta]C/M_T$$

*M*_T: Amount (g) of the Microcrystalline Cellulose taken, calculated on the dried basis

pH <2.54> Shake 5.0 g of Microcrystalline Cellulose with 40 mL of water for 20 minutes, and centrifuge: the pH of the supernatant liquid is between 5.0 and 7.5.

Purity ◇(1) Heavy metals <1.07>—Proceed with 2.0 g of Microcrystalline Cellulose according to Method 2, and perform the test. Prepare the control solution with 2.0 mL of Standard Lead Solution (not more than 10 ppm).◇

(2) Water-soluble substances—Shake 5.0 g of Microcrystalline Cellulose with 80 mL of water for 10 minutes, filter with the aid of vacuum through a filter paper for quantitative analysis (5C) into a vacuum flask. Evaporate the filtrate in a tared evaporating dish to dryness without charring, dry at 105°C for 1 hour, cool in a desiccator, and weigh: the difference between the mass of the residue and the mass obtained from a blank determination does not exceed 12.5 mg.

(3) Diethyl ether-soluble substances—Place 10.0 g of Microcrystalline Cellulose in a column having an internal diameter of about 20 mm, and pass 50 mL of peroxide-free diethyl ether through the column. Evaporate the eluate to dryness in a previously dried and tared evaporation dish. Dry the residue at 105°C for 30 minutes, allow to cool in a desiccator, and weigh: the difference between the mass of the residue and the mass obtained from a blank determination does not exceed 5.0 mg.

Conductivity <2.51> Perform the test as directed in the Conductivity Measurement with the supernatant liquid obtained in the pH as the sample solution, and determine the conductivity at 25 ± 0.1°C. Determine in the same manner the conductivity of water used for the preparation of the sample solution: the difference between these conductivities is not more than 75 μS·cm⁻¹.

Loss on drying <2.41> Not more than 7.0% ◇and within a range as specified on the label◇ (1 g, 105°C, 3 hours).

Residue on ignition <2.44> Not more than 0.1% (2 g).

Bulk density (i) Apparatus—Use a volumeter shown in the figure. Put a No.8.6 sieve (2000 μm) on the top of the volumeter. A funnel is mounted over a baffle box, having four glass baffle plates inside which the sample powder slides as it passes. At the bottom of the baffle box is a funnel that collect the powder, and allows it to pour into a sample receiving cup mounted directly below it.

Table for Conversion of Relative Viscosity (η_{rel}) into the Product of Limiting Viscosity and Concentration ($[\eta]C$)

η_{rel}	$[\eta]C$									
	0.00	0.01	0.02	0.03	0.04	0.05	0.06	0.07	0.08	0.09
1.1	0.098	0.106	0.115	0.125	0.134	0.143	0.152	0.161	0.170	0.180
1.2	0.189	0.198	0.207	0.216	0.225	0.233	0.242	0.250	0.259	0.268
1.3	0.276	0.285	0.293	0.302	0.310	0.318	0.326	0.334	0.342	0.350
1.4	0.358	0.367	0.375	0.383	0.391	0.399	0.407	0.414	0.422	0.430
1.5	0.437	0.445	0.453	0.460	0.468	0.476	0.484	0.491	0.499	0.507
1.6	0.515	0.522	0.529	0.536	0.544	0.551	0.558	0.566	0.573	0.580
1.7	0.587	0.595	0.602	0.608	0.615	0.622	0.629	0.636	0.642	0.649
1.8	0.656	0.663	0.670	0.677	0.683	0.690	0.697	0.704	0.710	0.717
1.9	0.723	0.730	0.736	0.743	0.749	0.756	0.762	0.769	0.775	0.782
2.0	0.788	0.795	0.802	0.809	0.815	0.821	0.827	0.833	0.840	0.846
2.1	0.852	0.858	0.864	0.870	0.876	0.882	0.888	0.894	0.900	0.906
2.2	0.912	0.918	0.924	0.929	0.935	0.941	0.948	0.953	0.959	0.965
2.3	0.971	0.976	0.983	0.988	0.994	1.000	1.006	1.011	1.017	1.022
2.4	1.028	1.033	1.039	1.044	1.050	1.056	1.061	1.067	1.072	1.078
2.5	1.083	1.089	1.094	1.100	1.105	1.111	1.116	1.121	1.126	1.131
2.6	1.137	1.142	1.147	1.153	1.158	1.163	1.169	1.174	1.179	1.184
2.7	1.190	1.195	1.200	1.205	1.210	1.215	1.220	1.225	1.230	1.235
2.8	1.240	1.245	1.250	1.255	1.260	1.265	1.270	1.275	1.280	1.285
2.9	1.290	1.295	1.300	1.305	1.310	1.314	1.319	1.324	1.329	1.333
3.0	1.338	1.343	1.348	1.352	1.357	1.362	1.367	1.371	1.376	1.381
3.1	1.386	1.390	1.395	1.400	1.405	1.409	1.414	1.418	1.423	1.427
3.2	1.432	1.436	1.441	1.446	1.450	1.455	1.459	1.464	1.468	1.473
3.3	1.477	1.482	1.486	1.491	1.496	1.500	1.504	1.508	1.513	1.517
3.4	1.521	1.525	1.529	1.533	1.537	1.542	1.546	1.550	1.554	1.558
3.5	1.562	1.566	1.570	1.575	1.579	1.583	1.587	1.591	1.595	1.600
3.6	1.604	1.608	1.612	1.617	1.621	1.625	1.629	1.633	1.637	1.642
3.7	1.646	1.650	1.654	1.658	1.662	1.666	1.671	1.675	1.679	1.683
3.8	1.687	1.691	1.695	1.700	1.704	1.708	1.712	1.715	1.719	1.723
3.9	1.727	1.731	1.735	1.739	1.742	1.746	1.750	1.754	1.758	1.762
4.0	1.765	1.769	1.773	1.777	1.781	1.785	1.789	1.792	1.796	1.800
4.1	1.804	1.808	1.811	1.815	1.819	1.822	1.826	1.830	1.833	1.837
4.2	1.841	1.845	1.848	1.852	1.856	1.859	1.863	1.867	1.870	1.874
4.3	1.878	1.882	1.885	1.889	1.893	1.896	1.900	1.904	1.907	1.911
4.4	1.914	1.918	1.921	1.925	1.929	1.932	1.936	1.939	1.943	1.946
4.5	1.950	1.954	1.957	1.961	1.964	1.968	1.971	1.975	1.979	1.982
4.6	1.986	1.989	1.993	1.996	2.000	2.003	2.007	2.010	2.013	2.017
4.7	2.020	2.023	2.027	2.030	2.033	2.037	2.040	2.043	2.047	2.050
4.8	2.053	2.057	2.060	2.063	2.067	2.070	2.073	2.077	2.080	2.083
4.9	2.087	2.090	2.093	2.097	2.100	2.103	2.107	2.110	2.113	2.116
5.0	2.119	2.122	2.125	2.129	2.132	2.135	2.139	2.142	2.145	2.148
5.1	2.151	2.154	2.158	2.160	2.164	2.167	2.170	2.173	2.176	2.180
5.2	2.183	2.186	2.190	2.192	2.195	2.197	2.200	2.203	2.206	2.209
5.3	2.212	2.215	2.218	2.221	2.224	2.227	2.230	2.233	2.236	2.240
5.4	2.243	2.246	2.249	2.252	2.255	2.258	2.261	2.264	2.267	2.270
5.5	2.273	2.276	2.279	2.282	2.285	2.288	2.291	2.294	2.297	2.300
5.6	2.303	2.306	2.309	2.312	2.315	2.318	2.320	2.324	2.326	2.329
5.7	2.332	2.335	2.338	2.341	2.344	2.347	2.350	2.353	2.355	2.358
5.8	2.361	2.364	2.367	2.370	2.373	2.376	2.379	2.382	2.384	2.387
5.9	2.390	2.393	2.396	2.400	2.403	2.405	2.408	2.411	2.414	2.417
6.0	2.419	2.422	2.425	2.428	2.431	2.433	2.436	2.439	2.442	2.444
6.1	2.447	2.450	2.453	2.456	2.458	2.461	2.464	2.467	2.470	2.472
6.2	2.475	2.478	2.481	2.483	2.486	2.489	2.492	2.494	2.497	2.500
6.3	2.503	2.505	2.508	2.511	2.513	2.516	2.518	2.521	2.524	2.526
6.4	2.529	2.532	2.534	2.537	2.540	2.542	2.545	2.547	2.550	2.553
6.5	2.555	2.558	2.561	2.563	2.566	2.568	2.571	2.574	2.576	2.579
6.6	2.581	2.584	2.587	2.590	2.592	2.595	2.597	2.600	2.603	2.605
6.7	2.608	2.610	2.613	2.615	2.618	2.620	2.623	2.625	2.627	2.630
6.8	2.633	2.635	2.637	2.640	2.643	2.645	2.648	2.650	2.653	2.655
6.9	2.658	2.660	2.663	2.665	2.668	2.670	2.673	2.675	2.678	2.680

η_{rel}	$[\eta]C$									
	0.00	0.01	0.02	0.03	0.04	0.05	0.06	0.07	0.08	0.09
7.0	2.683	2.685	2.687	2.690	2.693	2.695	2.698	2.700	2.702	2.705
7.1	2.707	2.710	2.712	2.714	2.717	2.719	2.721	2.724	2.726	2.729
7.2	2.731	2.733	2.736	2.738	2.740	2.743	2.745	2.748	2.750	2.752
7.3	2.755	2.757	2.760	2.762	2.764	2.767	2.769	2.771	2.774	2.776
7.4	2.779	2.781	2.783	2.786	2.788	2.790	2.793	2.795	2.798	2.800
7.5	2.802	2.805	2.807	2.809	2.812	2.814	2.816	2.819	2.821	2.823
7.6	2.826	2.828	2.830	2.833	2.835	2.837	2.840	2.842	2.844	2.847
7.7	2.849	2.851	2.854	2.856	2.858	2.860	2.863	2.865	2.868	2.870
7.8	2.873	2.875	2.877	2.879	2.881	2.884	2.887	2.889	2.891	2.893
7.9	2.895	2.898	2.900	2.902	2.905	2.907	2.909	2.911	2.913	2.915
8.0	2.918	2.920	2.922	2.924	2.926	2.928	2.931	2.933	2.935	2.937
8.1	2.939	2.942	2.944	2.946	2.948	2.950	2.952	2.955	2.957	2.959
8.2	2.961	2.963	2.966	2.968	2.970	2.972	2.974	2.976	2.979	2.981
8.3	2.983	2.985	2.987	2.990	2.992	2.994	2.996	2.998	3.000	3.002
8.4	3.004	3.006	3.008	3.010	3.012	3.015	3.017	3.019	3.021	3.023
8.5	3.025	3.027	3.029	3.031	3.033	3.035	3.037	3.040	3.042	3.044
8.6	3.046	3.048	3.050	3.052	3.054	3.056	3.058	3.060	3.062	3.064
8.7	3.067	3.069	3.071	3.073	3.075	3.077	3.079	3.081	3.083	3.085
8.8	3.087	3.089	3.092	3.094	3.096	3.098	3.100	3.102	3.104	3.106
8.9	3.108	3.110	3.112	3.114	3.116	3.118	3.120	3.122	3.124	3.126
9.0	3.128	3.130	3.132	3.134	3.136	3.138	3.140	3.142	3.144	3.146
9.1	3.148	3.150	3.152	3.154	3.156	3.158	3.160	3.162	3.164	3.166
9.2	3.168	3.170	3.172	3.174	3.176	3.178	3.180	3.182	3.184	3.186
9.3	3.188	3.190	3.192	3.194	3.196	3.198	3.200	3.202	3.204	3.206
9.4	3.208	3.210	3.212	3.214	3.215	3.217	3.219	3.221	3.223	3.225
9.5	3.227	3.229	3.231	3.233	3.235	3.237	3.239	3.241	3.242	3.244
9.6	3.246	3.248	3.250	3.252	3.254	3.256	3.258	3.260	3.262	3.264
9.7	3.266	3.268	3.269	3.271	3.273	3.275	3.277	3.279	3.281	3.283
9.8	3.285	3.287	3.289	3.291	3.293	3.295	3.297	3.298	3.300	3.302
9.9	3.304	3.305	3.307	3.309	3.311	3.313	3.316	3.318	3.320	3.321
10	3.32	3.34	3.36	3.37	3.39	3.41	3.43	3.45	3.46	3.48
11	3.50	3.52	3.53	3.55	3.56	3.58	3.60	3.61	3.63	3.64
12	3.66	3.68	3.69	3.71	3.72	3.74	3.76	3.77	3.79	3.80
13	3.80	3.83	3.85	3.86	3.88	3.89	3.90	3.92	3.93	3.95
14	3.96	3.97	3.99	4.00	4.02	4.03	4.04	4.06	4.07	4.09
15	4.10	4.11	4.13	4.14	4.15	4.17	4.18	4.19	4.20	4.22
16	4.23	4.24	4.25	4.27	4.28	4.29	4.30	4.31	4.33	4.34
17	4.35	4.36	4.37	4.38	4.39	4.41	4.42	4.43	4.44	4.45
18	4.46	4.47	4.48	4.49	4.50	4.52	4.53	4.54	4.55	4.56
19	4.57	4.58	4.59	4.60	4.61	4.62	4.63	4.64	4.65	4.66

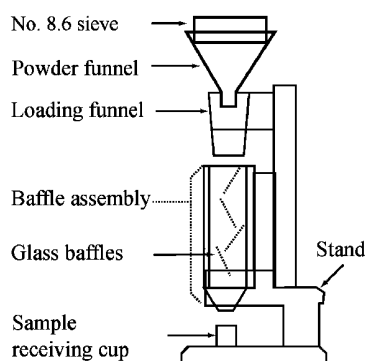

(ii) Procedure—Weigh accurately the mass of a brass or stainless steel cup, which has a capacity of 25.0 ± 0.05 mL and an inside diameter of 30.0 ± 2.0 mm, and put the cup directly below the funnel of the volumeter. Slowly pour Microcrystalline Cellulose 5.1 cm height from the upper part of the powder funnel through the sieve, at a rate suitable to

prevent clogging, until the cup overflows. If the clogging occurs, take out the sieve. Level the excess powder with the aid of a slide glass, weigh the filled cup, and weigh accurately the content of the cup, and then calculate the bulk density by the following expression: the bulk density is within the labeled specification.

$$\text{Bulk density (g/cm}^3\text{)} = A/25$$

A: Measured mass (g) of the content of the cup

Microbial limit <4.05> The acceptance criteria of TAMC and TYMC are 10^3 CFU/g and 10^2 CFU/g, respectively. *Escherichia coli*, *Salmonella*, *Pseudomonas aeruginosa* and *Staphylococcus aureus* are not observed.

◆**Containers and storage** Containers—Tight containers.◆

Powdered Cellulose

粉末セルロース

[9004-34-6, Cellulose]

This monograph is harmonized with the European Pharmacopoeia and the U.S. Pharmacopoeia.

The parts of the text that are not harmonized are marked with symbols (◆ ◆).

Information on the harmonization with the European Pharmacopoeia and the U.S. Pharmacopoeia is available on the website of the Pharmaceuticals and Medical Devices Agency.

Powdered Cellulose is a purified, mechanically disintegrated alpha cellulose obtained as a pulp, ◆ after partial hydrolysis as occasion demands◆, from fibrous plant materials.

The label indicates the mean degree of polymerization value with a range.

◆**Description** Powdered Cellulose occurs as a white powder.

It is practically insoluble in water, in ethanol (95) and in diethyl ether.◆

Identification (1) Dissolve 20 g of zinc chloride and 6.5 g of potassium iodide in 10.5 mL of water, add 0.5 g of iodine, and shake for 15 minutes. Place about 10 mg of Powdered Cellulose on a watch glass, and disperse in 2 mL of this solution: the substance develops a blue-violet color.

◆(2) Mix 30 g of Powdered Cellulose with 270 mL of water in a high-speed (18,000 revolutions per minute or more) blender for 5 minutes, transfer 100 mL of the dispersion to a 100-mL graduated cylinder, and allow to stand for 1 hour: a supernatant liquid appears above the layer of the cellulose.◆

(3) Transfer 0.25 g of Powdered Cellulose, accurately weighed, to a 125-mL conical flask, add exactly 25 mL each of water and 1 mol/L cupriethylenediamine TS, and proceed as directed in the Identification (3) under Microcrystalline Cellulose. The mean degree of polymerization, P, is not less than 440 and is within the labeled specification.

pH <2.54> Mix 10 g of Powdered Cellulose with 90 mL of water, and allow to stand for 1 hour with occasional stirring: the pH of the supernatant liquid is between 5.0 and 7.5.

Purity ◆(1) Heavy metals <1.07>—Proceed with 2.0 g of Powdered Cellulose according to Method 2, and perform the test. Prepare the control solution with 2.0 mL of Standard Lead Solution (not more than 10 ppm).◆

(2) Water-soluble substances—Shake 6.0 g of Powdered Cellulose with 90 mL of recently boiled and cooled water, and allow to stand for 10 minutes with occasional shaking. Filter, with the aid of vacuum through a filter paper, discard the first 10 mL of the filtrate, and pass the subsequent filtrate through the same filter, if necessary, to obtain a clear filtrate. Evaporate a 15.0-mL portion of the filtrate in a tared evaporating dish to dryness without charring, dry at 105°C for 1 hour, and weigh after allowing to cool in a desiccator: the difference between the mass of the residue and the mass obtained from a blank determination does not exceed 15.0 mg (1.5%).

(3) Diethyl ether-soluble substances—Place 10.0 g of Powdered Cellulose in a column having an internal diameter of about 20 mm, and pass 50 mL of peroxide-free diethyl

ether through the column. Evaporate the eluate to dryness in a previously dried and tared evaporation dish. Dry the residue at 105°C for 30 minutes, and weigh after allowing to cool in a desiccator: the difference between the mass of the residue and the mass obtained from a blank determination does not exceed 15.0 mg (0.15%).

Loss on drying <2.41> Not more than 6.5% (1 g, 105°C, 3 hours).

Residue on ignition <2.44> Not more than 0.3% (1 g calculated on the dried basis).

◆**Microbial limit** <4.05> The acceptance criteria of TAMC and TYMC are 10³ CFU/g and 10² CFU/g, respectively. *Escherichia coli*, *Salmonella*, *Pseudomonas aeruginosa* and *Staphylococcus aureus* are not observed.◆

◆**Containers and storage** Containers—Tight containers.◆

Celmoleukin (Genetical Recombination)

セルモロイキン(遺伝子組換え)

```

APTSSSTKKT QLQLEHLLLD LQMLNGINN YKNPKLTRML TFKFYMPKKA
TELKHLQCLE EELKPLEEVL NLAQSKNFHL RPRDLISNIN VIVLELKGSE
TTFMCEYADE TATIVEFLNR WITFCQSIIS TLT

```

C₆₉₃H₁₁₁₈N₁₇₈O₂₀₃S₇: 15415.82
[94218-72-1]

Celmoleukin (Genetical Recombination) is a recombinant human interleukin-2, and is a protein consisting of 133 amino acid residues. It is a solution.

It contains not less than 0.5 and not more than 1.5 mg of protein per mL, and 1 mg of this protein contains potency not less than 8.0 × 10⁶ units.

Description Celmoleukin (Genetical Recombination) occurs as a clear and colorless liquid.

Identification (1) Add 100 μL of protein digestive enzyme TS to 100 μL of Celmoleukin (Genetical Recombination), shake, leave standing at 37°C for 18 to 24 hours, and then add 2 μL of 2-mercaptoethanol. Leave at 37°C for a further 30 minutes, and add 5 μL of trifluoroacetic acid solution (1 in 10). Use this solution as the sample solution. Separately, process with celmoleukin for liquid chromatography by using the same method. Use this solution as the standard solution. Perform the test with 50 μL each of the sample solution and standard solution as directed under Liquid Chromatography <2.01> according to the following conditions, and compare the chromatograms obtained from the sample solution and standard solution: the similar peaks are observed at the same retention time.

Operating conditions—

Detector: An ultraviolet absorption photometer (wavelength: 215 nm).

Column: A stainless steel column 4 mm in inside diameter and 30 cm in length, packed with octadecylsilanized silica gel for liquid chromatography (particle size: 5 μm).

Column temperature: A constant temperature of about 25°C.

Mobile phase A: A solution of trifluoroacetic acid (1 in 1000).

Mobile phase B: A solution of trifluoroacetic acid in a

mixture of acetonitrile and water (17:3) (1 in 1000).

Flowing of mobile phase: Control the gradient by mixing the mobile phases A and B as directed in the following table.

Time after injection of sample (min)	Mobile phase A (vol%)	Mobile phase B (vol%)
0 – 5	100	0
5 – 45	100 → 60	0 → 40
45 – 75	60 → 0	40 → 100
75 – 85	0	100

Flow rate: Adjust so that the retention time of celmoleukin is about 70 minutes.

System suitability—

System performance: Add 2 μL of 2-mercaptoethanol to 100 μL of celmoleukin for liquid chromatography, leave at 37°C for 2 hours, and then run this solution under the above operating conditions. Celmoleukin and its reduced form are eluted in this order with the resolution between these peaks being not less than 1.5.

(2) Accurately measure an appropriate amount of Celmoleukin (Genetical Recombination), dilute by adding culture medium for celmoleukin, and prepare a sample solution containing 800 units per mL. Add 25 μL of the sample solution to 2 wells (A and B) of a flat-bottomed microtest plate for tissue culture, and then add 25 μL of reference anti-interleukin-2 antiserum solution diluted with culture medium for celmoleukin to well A and 25 μL of culture medium for celmoleukin to well B. Add 50 μL of culture medium for celmoleukin to another well (well C). After shaking the microtest plate, warm in air containing 5% carbon dioxide at 37°C for 30 minutes to 2 hours. Next, add to each well 50 μL of culture medium for celmoleukin containing the interleukin-2 dependent mouse natural killer cells NKC3 and culture at 37°C for 16 to 24 hours. Add 3-(4,5-dimethylthiazole-2-yl)-2,5-diphenyl-2*H*-tetrazolium bromide TS, culture at 37°C for 4 to 6 hours, and add sodium lauryl sulfate TS and leave for 24 to 48 hours. When the absorbance at 590 nm of the solution in each well is measured, the difference in absorbance between the solutions from wells A and C is not more than 3% of the difference in absorbance between the solutions from wells B and C.

Constituent amino acid When hydrolyze Celmoleukin (Genetical Recombination) according to Method 1 and Method 4 described in “1. Hydrolysis of Protein and Peptide”, and perform the test according to Method 1 described in “2. Methodologies of Amino Acid Analysis” under Amino Acid Analysis of Proteins <2.04>, the molar ratios of the respective amino acids are as follows: glutamic acid (or glutamine) is 17 or 18, threonine is 11 to 13, aspartic acid (or asparagine) is 11 or 12, lysine is 11, isoleucine is 7 or 8, serine is 6 to 9, phenylalanine is 6, alanine is 5, proline is 5 or 6, arginine is 4, methionine is 4, cysteine is 3 or 4, valine is 3 or 4, tyrosine is 3, histidine is 3, glycine is 2, and tryptophan is 1.

Procedure

(i) Hydrolysis Based on the results of the Assay (1), place an amount of Celmoleukin (Genetical Recombination), equivalent to about 50 μg as the total protein in two hydrolysis tubes, and evaporate to dryness under vacuum. To one of the hydrolysis tubes add 100 μL of a mixture of diluted hydrochloric acid (59 in 125), mercapto acetic acid and phenol (100:10:1), and shake. Place this hydrolysis tube in a vial and humidify the inside of the vial with 200 μL of the mixture of diluted hydrochloric acid (59 in 125), mercapto acetic acid

and phenol (100:10:1). Replace the vial interior with inert gas or reduce the pressure, and heat at about 115°C for 24 hours. After drying under vacuum, dissolve in 0.5 mL of 0.02 mol/L hydrochloric acid TS, and use this solution as the sample solution (1). To the other hydrolysis tube, add 100 μL of ice cold performic acid, oxidize for 1.5 hours on ice, add 50 μL of hydrobromic acid, and dry under vacuum. Add 200 μL of water, repeat the dry under vacuum procedure two more times, place the hydrolysis tube in a vial, and humidify the inside of the vial with 200 μL of diluted hydrochloric acid (59 in 125). Replace the vial interior with inert gas or reduce the pressure, and heat at about 115°C for 24 hours. After drying under vacuum, dissolve in 0.5 mL of 0.02 mol/L hydrochloric acid TS, and use this solution as the sample solution (2). Separately, weigh exactly 60 mg of L-aspartic acid, 100 mg of L-glutamic acid, 17 mg of L-alanine, 23 mg of L-methionine, 21 mg of L-tyrosine, 24 mg of L-histidine hydrochloride monohydrate, 58 mg of L-threonine, 22 mg of L-proline, 14 mg of L-cystine, 45 mg of L-isoleucine, 37 mg of L-phenylalanine, 32 mg of L-arginine hydrochloride, 32 mg of L-serine, 6 mg of glycine, 18 mg of L-valine, 109 mg of L-leucine, 76 mg of L-lysine hydrochloride, and 8 mg of L-tryptophan, dissolve with 0.1 mol/L hydrochloric acid TS to make exactly 500 mL, and use this solution as the standard solution. Transfer 40 μL each of the standard solution to two hydrolysis tubes, evaporate to dryness under vacuum, and proceed in the same way for each respective sample solution to make the standard solutions (1) and (2).

(ii) Amino acid analysis Perform the test with exactly 250 μL each of the sample solutions (1) and (2) and standard solutions (1) and (2) as directed under Liquid Chromatography <2.01> according to the following conditions, and from the peak areas for each amino acid obtained from the sample solutions (1) and (2) and standard solutions (1) and (2) calculate the molar number of the amino acids contained in 1 mL of the sample solutions (1) and (2). Furthermore, calculate the number of amino acids assuming there are 22 leucine residues in one mole of celmoleukin.

Operating conditions—

Detector: A visible absorption photometer [wavelength: 440 nm (proline) and 570 nm (amino acids other than proline)].

Column: A stainless steel column 4 mm in inside diameter and 25 cm in length, packed with strongly acidic ionexchange resin for liquid chromatography (Na type) (sulfonic acid group bound divinylbenzenepolystyrene) (5 μm in particle diameter).

Column temperature: Maintaining a constant temperature of about 48°C for 28 minutes after sample injection, then a constant temperature of about 62°C until 121 minutes after the injection.

Reaction temperature: A constant temperature of about 135°C.

Color developing time: About 1 minute.

Mobile phases A, B, C and D: Prepare according to the following table.

Mobile phase	A	B	C	D
Citric acid monohydrate	17.70 g	10.50 g	6.10 g	—
Trisodium citrate dihydrate	7.74 g	15.70 g	26.67 g	—
Sodium chloride	7.07 g	2.92 g	54.35 g	—
Sodium hydroxide	—	—	2.30 g	8.00 g
Methanol (99.5)	40 mL	—	—	—
Benzyl alcohol	—	10 mL	5 mL	—
Thiodiglycol	5 mL	5 mL	5 mL	—
Lauromacrogol solution (1 in 4)	4 mL	4 mL	4 mL	4 mL
Caprylic acid	0.1 mL	0.1 mL	0.1 mL	0.1 mL
Water	a sufficient quantity	a sufficient quantity	a sufficient quantity	a sufficient quantity
Total	1000 mL	1000 mL	1000 mL	1000 mL

Flowing of mobile phase: Control the gradient by mixing the mobile phases A, B, C and D as directed in the following table.

Time after injection of sample (min)	Mobile phase A (vol%)	Mobile phase B (vol%)	Mobile phase C (vol%)	Mobile phase D (vol%)
0 - 35	100	0	0	0
35 - 60	0	100	0	0
60 - 111	0	0	100	0
111 - 121	0	0	0	100

Reaction reagent: Mix 407 g of lithium acetate dihydrate, 245 mL of acetic acid (100) and 801 mL of 1-methoxy-2-propanol, add water to make 2000 mL, stir for 10 minutes while passing a current of nitrogen, and assign as solution A. Separately, to 1957 mL of 1-methoxy-2-propanol add 77 g of ninhydrin and 0.134 g of sodium borohydride, stir for 30 minutes while passing a current of nitrogen, and assign as solution B. Mix solutions A and B before use.

Flow rate of mobile phase: Adjust so that the retention times of serine and leucine are about 30 minutes and about 73 minutes, respectively (about 0.21 mL per minute).

Flow rate of reaction reagent: About 0.25 mL per minute.

System suitability—

System performance: To 2 mL of the standard solution add 0.02 mol/L hydrochloric acid TS to make 25 mL. When the procedure is run with 250 μ L of this solution under the above operating conditions, the resolution between the peaks of threonine and serine is not less than 1.2.

System repeatability: To 2 mL of the standard solution add 0.02 mol/L hydrochloric acid TS to make 25 mL. When the test is repeated 3 times with 250 μ L of this solution under the above operating conditions, the relative standard deviation of the peak area of aspartic acid, serine, arginine and proline is not more than 2.4%.

Molecular mass Based on the results of the Assay (1), add buffer for celmoleukin and dilute to prepare a sample solution so that there is about 0.5 mg of protein per mL. To vertical uncontinuous buffer SDS-polyacrylamide gel prepared from resolving gel for celmoleukin and stacking gel for celmoleukin add 20 μ L of the sample solution or 20 μ L of marker protein for celmoleukin molecular mass determination to each stacking gel well, and perform the electrophoresis. The molecular mass of the main electrophoretic band is between 12,500 and 13,800 when the band is stained by immersion in Coomassie staining TS.

pH <2.54> 4.5 - 5.5

Purity (1) Related substances—Perform the test with 10 μ L each of Celmoleukin (Genetical Recombination) and 0.01 mol/L acetic acid buffer solution (pH 5.0) as directed under Liquid Chromatography <2.01> under the following conditions, and measure the area of each peak by an automatic integration method. When the amounts of related substances other than celmoleukin are calculated by the area percentage method, the total amount is not more than 5%.

Operating conditions—

Detector: An ultraviolet absorption photometer (wavelength: 215 nm).

Column: Stainless steel tube with an inside diameter of 4 mm and a length of 30 cm packed with octadecylsilanized silica gel for liquid chromatography (particle size: 5 μ m).

Column temperature: A constant temperature of about 25°C.

Mobile phase A: A solution of trifluoroacetic acid in a mixture of acetic acid and water (3:2) (1 in 1000).

Mobile phase B: A solution of trifluoroacetic acid in a mixture of acetic acid and water (13:7) (1 in 1000).

Flowing of mobile phase: Control the gradient by mixing the mobile phases A and B as directed in the following table.

Time after injection of sample (min)	Mobile phase A (vol%)	Mobile phase B (vol%)
0 - 60	70 → 10	30 → 90

Flow rate: Adjust so that the retention time of celmoleukin is about 50 minutes.

Time span of measurement: About 1.3 times as long as the retention time of celmoleukin, beginning after the solvent peak.

System suitability—

Test for required detectability: Measure exactly 0.5 mL of Celmoleukin (Genetical Recombination), and add 0.01 mol/L acetic acid buffer solution (pH 5.0) to make exactly 50 mL. Confirm that the peak area of celmoleukin obtained with 10 μ L of this solution is equivalent to 0.9 to 1.1% of the peak area with 10 μ L of Celmoleukin (Genetical Recombination).

System performance: Add 2 μ L of 2-mercaptoethanol to 100 μ L of Celmoleukin (Genetical Recombination), leave at 37°C for 2 hours, and then run this solution under the above conditions. Celmoleukin and its reduced form are eluted in this order with the resolution between these peaks being not less than 3.0.

(2) Multimers—Dilute (at least 4 steps) the sample solution prepared in the Molecular mass with buffer solution for celmoleukin so that the protein content is within the range of 2 to 32 μ g per mL to prepare a series of standard solutions. Pipet 20 μ L each of the sample solution and the standard solutions into the stacking gel well, and perform vertical uncoupled buffer SDS-polyacrylamide gel electrophoresis followed by immersion in Coomassie staining TS. Each electrophoretic band is stained blue. Next, determine the peak area of the electrophoretic bands obtained from each standard solution using a densitometer and calculate the protein content using the calibration curve mentioned above. When determining the polymer proteins derived from celmoleukin, other than celmoleukin monomer, the amount is not more than 2% in relation to the total protein.

(3) Host cell proteins—Being specified separately when the drug is granted approval based on the Law.

(4) Host cell DNA—Being specified separately when the drug is granted approval based on the Law.

Bacterial endotoxins <4.01> Less than 100 EU/mL.

Ammonium acetate Measure exactly 0.1 mL of Celmoleukin (Genetical Recombination), add water to make exactly 10 mL, and use this solution as the sample solution. Separately, weigh accurately about 0.1 g of ammonium chloride, and add water to make exactly 100 mL. Measure exactly 5 mL of this solution, add water to make exactly 100 mL, and use this solution as the standard stock solution. Measure exactly 3 mL of the standard stock solution, add water to make exactly 50 mL, and use this solution as the standard solution. Perform the test with exactly 25 μ L each of the sample solution and standard solution as directed under Liquid Chromatography <2.01> according to the following conditions. When determining the area of the ammonium ion peak A_T and A_S , Celmoleukin (Genetical Recombination) contains not less than 0.28 mg and not more than 0.49 mg of ammonium acetate per mL.

Amount (mg) of ammonium acetate ($\text{CH}_3\text{COONH}_4$) per mL
 $= A_T/A_S \times M_S \times 0.003 \times 1.441$

M_S : Amount (mg) of ammonium chloride taken

0.003: Dilution correction factor

1.441: Molecular mass conversion coefficient for converting ammonium chloride to ammonium acetate

Operating conditions—

Detector: An electric conductivity detector.

Column: Resin column 5 mm in inside diameter and 25 cm in length, packed with weakly acidic ion exchange resin for liquid chromatography (particle size: 5.5 μ m).

Column temperature: A constant temperature of about 40°C.

Mobile phase: Diluted 0.1 mol/L methanesulfonic acid TS (3 in 10).

Flow rate: Adjust so that the retention time of ammonium is about 8 minutes.

System suitability—

System performance: Measure exactly 1 mL of Standard Sodium Stock Solution and 0.2 mL of Standard Potassium Stock Solution, and then add water to make exactly 100 mL. Measure exactly 5 mL of this solution and 3 mL of Standard Ammonium Solution, and then add water to make exactly 50 mL. When 25 μ L of this solution is run under the above conditions, sodium, ammonium and potassium are eluted in this order with the resolution between the peaks of sodium and ammonium being not less than 3.0.

System repeatability: When the test is repeated 5 times with 25 μ L of the standard solution under the above conditions, the relative standard deviation of the ammonium peak area is not more than 10%.

Assay (1) Total protein content—Measure accurately 1 mL of Celmoleukin (Genetical Recombination) and add water to make exactly 10 mL. Use this solution as the sample solution. Separately, weigh accurately about 50 mg of bovine serum albumin for assay in water to prepare standard dilution solutions of 50, 100, and 150 μ g/mL. Measure exactly 1 mL of the sample solution and each standard dilution solution, add exactly 2.5 mL of alkaline copper TS for protein content determination, shake, and leave for 15 minutes. Next, add exactly 2.5 mL of water and 0.5 mL of dilute Folin's TS, and leave at 37°C for 30 minutes. Measure the absorbances of these solutions at 750 nm as directed under Ultraviolet-visible Spectrophotometry <2.24>, using 1 mL of water processed in the same way as control. Using the calibration curve prepared from the absorbance of the standard dilution solution, calculate the protein content of Cel-

moleukin (Genetical Recombination).

(2) Specific activity—Measure exactly 0.1 mL of Celmoleukin (Genetical Recombination) and add exactly 0.9 mL of culture medium for celmoleukin to make the sample solution. Separately, take one Interleukin-2 RS and add exactly 1 mL of water to dissolve. This is the standard solution. Dilute exactly the sample and standard solutions in serially two-fold steps with culture medium for celmoleukin, and add equal volumes of interleukin-2 dependent mouse natural killer NKC3 cells to the serially diluted solutions. The control solution is a mixture of equal volumes of interleukin-2 dependent mouse natural killer NKC3 and culture medium for celmoleukin. Incubate these solutions at 37°C for 16 to 24 hours. Following this, add a volume of 3-(4,5-dimethylthiazole-2-yl)-2,5-diphenyl-2H-tetrazolium bromide TS that is 1/5 that of the volume of culture medium for celmoleukin, incubate at 37°C for 4 to 6 hours, add a volume of sodium lauryl sulfate TS equivalent to the volume of the culture medium for celmoleukin, and leave for 24 to 48 hours. After eluting the blue-colored pigment generated, perform the test on these solutions as directed under Ultraviolet-visible Spectrophotometry <2.24>, and measure the absorbance at 590 nm. Taking the absorbance obtained when 1000 to 2000 units of celmoleukin per mL are added as 100% and the absorbance of the control solution as 0%, determine the dilution factor (A) of the Interleukin-2 RS that shows an absorbance of 50% and dilution factor of Celmoleukin (Genetical Recombination) (B). Multiply the B/A value by the unit number of the Interleukin-2 RS to calculate the biological activity of 1 mL of Celmoleukin (Genetical Recombination). Calculate the ratio of biological activity in relation to protein content determined in the total protein content test.

Containers and storage Containers—Tight containers.

Storage—At -20°C or lower.

Cetanol

セタノール

Cetanol is a mixture of solid alcohols, and consists chiefly of cetanol ($\text{C}_{16}\text{H}_{34}\text{O}$: 242.44).

Description Cetanol occurs as unctuous, white, flakes, granules, or masses. It has a faint, characteristic odor. It is tasteless.

It is very soluble in pyridine, freely soluble in ethanol (95), in ethanol (99.5) and in diethyl ether, very slightly soluble in acetic anhydride, and practically insoluble in water.

Melting point <1.13> 47 – 53°C Prepare the sample according to Method 2, then attach tightly a capillary tube to the bottom of the thermometer by means of a rubber band or by any suitable means, and make the bottom of the capillary tube equal in position to the lower end of the thermometer. Insert this thermometer into a test tube 17 mm in inside diameter and about 170 mm in height, fasten the thermometer with cork stopper so that the lower end of the thermometer is about 25 mm distant from the bottom of the test tube. Suspend the test tube in a beaker containing water, and heat the beaker with constant stirring until the temperature rises to 5°C below the expected melting point. Then regulate the rate of increase to 1°C per minute. The temperature at which the sample is transparent and no turbidity is produced is taken as the melting point.

Acid value <1.13> Not more than 1.0.

Ester value <1.13> Not more than 2.0.

Hydroxyl value <1.13> 210 – 232

Iodine value <1.13> Not more than 2.0.

Purity (1) Clarity of solution—Dissolve 3.0 g of Cetanol in 25 mL of ethanol (99.5) by warming; the solution is clear.

(2) Alkalinity—To the solution obtained in (1) add 2 drops of phenolphthalein TS: no red color develops.

Residue on ignition <2.44> Not more than 0.05% (2 g).

Containers and storage Containers—Well-closed containers.

Cetirizine Hydrochloride

セチリジン塩酸塩

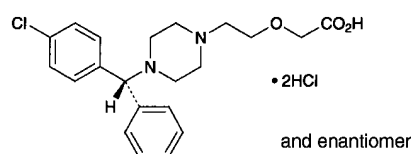

$C_{21}H_{25}ClN_2O_3 \cdot 2HCl$: 461.81

2-(2-{4-[(*RS*)-(4-Chlorophenyl)(phenyl)methyl]piperazin-1-yl}ethoxy)acetic acid dihydrochloride
[83881-52-1]

Cetirizine Hydrochloride, when dried, contains not less than 99.0% and not more than 101.0% of cetirizine hydrochloride ($C_{21}H_{25}ClN_2O_3 \cdot 2HCl$).

Description Cetirizine Hydrochloride occurs as a white crystalline powder.

It is very soluble in water, and slightly soluble in ethanol (99.5).

It dissolves in 0.1 mol/L hydrochloric acid TS.

A solution of Cetirizine Hydrochloride (1 in 10) shows no optical rotation.

Identification (1) Determine the absorption spectrum of a solution of Cetirizine Hydrochloride in 0.1 mol/L hydrochloric acid TS (1 in 50,000) as directed under Ultraviolet-visible Spectrophotometry <2.24>, and compare the spectrum with the Reference Spectrum: both spectra exhibit similar intensities of absorption at the same wavelengths.

(2) Determine the infrared absorption spectrum of Cetirizine Hydrochloride as directed in the potassium chloride disk method under Infrared Spectrophotometry <2.25>, and compare the spectrum with the Reference Spectrum: both spectra exhibit similar intensities of absorption at the same wave numbers.

(3) A solution of Cetirizine Hydrochloride (1 in 100) responds to Qualitative Tests <1.09> for chloride.

Purity (1) Heavy metals <1.07>—Proceed with 2.0 g of Cetirizine Hydrochloride according to Method 2, and perform the test. Prepare the control solution with 2.0 mL of Standard Lead Solution (not more than 10 ppm).

(2) Related substances—Dissolve 0.10 g of Cetirizine Hydrochloride in 50 mL of the mobile phase, and use this solution as the sample solution. Pipet 2 mL of the sample solution, add the mobile phase to make exactly 50 mL. Pipet 5 mL of this solution, add the mobile phase to make exactly 100 mL, and use this solution as the standard solution. Perform the test with exactly 10 μ L each of the sample solution

and standard solution as directed under Liquid Chromatography <2.01> according to the following conditions, and determine each peak area of each solution by the automatic integration method: the area of each peak other than cetirizine obtained from the sample solution is not larger than the peak area of cetirizine from the standard solution. And the total area of the peaks other than cetirizine from the sample solution is not larger than 2.5 times the peak area of cetirizine from the standard solution.

Operating conditions—

Detector: An ultraviolet absorption photometer (wavelength: 230 nm).

Column: A stainless steel column 4.0 mm in inside diameter and 25 cm in length, packed with silica gel for liquid chromatography (5 μ m in particle diameter).

Column temperature: A constant temperature of about 25°C.

Mobile phase: A mixture of acetonitrile and diluted 0.5 mol/L sulfuric acid TS (2 in 25) (47:3).

Flow rate: Adjust so that the retention time of cetirizine is about 9 minutes.

Time span of measurement: About 3 times as long as the retention time of cetirizine, beginning after the solvent peak.

System suitability—

Test for required detectability: Pipet 5 mL of the standard solution, and add the mobile phase to make exactly 10 mL. Confirm that the peak area of cetirizine obtained with 10 μ L of this solution is equivalent to 35 to 65% of that with 10 μ L of the standard solution.

System performance: Dissolve 20 mg of Cetirizine Hydrochloride in the mobile phase to make 100 mL. To 5 mL of this solution, add 3 mL of a solution of aminopyrine in the mobile phase (1 in 2500), and add the mobile phase to make 20 mL. When the procedure is run with 10 μ L of this solution under the above operating conditions, cetirizine and aminopyrine are eluted in this order with the resolution between these peaks being not less than 7.

System repeatability: When the test is repeated 6 times with 10 μ L of the standard solution under the above operating conditions, the relative standard deviation of the peak area of cetirizine is not more than 2.0%.

Loss on drying <2.41> Not more than 0.5% (1 g, in vacuum, 60°C, 3 hours).

Residue on ignition <2.44> Not more than 0.2% (1 g).

Assay Weigh accurately about 0.1 g of Cetirizine Hydrochloride, previously dried, dissolve in 70 mL of a mixture of acetone and water (7:3), and titrate <2.50> to the second equivalence point with 0.1 mol/L sodium hydroxide VS (potentiometric titration). Perform a blank determination in the same manner, and make any necessary correction.

Each mL of 0.1 mol/L sodium hydroxide VS
= 15.39 mg of $C_{21}H_{25}ClN_2O_3 \cdot 2HCl$

Containers and storage Containers—Well-closed containers.

Cetirizine Hydrochloride Tablets

セチリジン塩酸塩錠

Cetirizine Hydrochloride Tablets contain not less than 95.0% and not more than 105.0% of the labeled amount of cetirizine hydrochloride ($C_{21}H_{25}ClN_2O_3 \cdot 2HCl$; 461.81).

Method of preparation Prepare as directed under Tablets, with Cetirizine Hydrochloride.

Identification To a quantity of powdered Cetirizine Hydrochloride Tablets, equivalent to 10 mg of Cetirizine Hydrochloride, add about 70 mL of 0.1 mol/L hydrochloric acid TS, shake, add 0.1 mol/L hydrochloric acid TS to make 100 mL, and filter. To 4 mL of the filtrate add 0.1 mol/L hydrochloric acid TS to make 25 mL, and determine the absorption spectrum of this solution as directed under Ultraviolet-visible Spectrophotometry <2.24>: it exhibits a maximum between 230 nm and 234 nm.

Uniformity of dosage units <6.02> Perform the test according to the following method: it meets the requirement of the Content uniformity test.

Take 1 tablet of Cetirizine Hydrochloride Tablets, add $4V/5$ mL of sodium 1-heptanesulfonate solution (1 in 5000) adjusted to pH 3.0 with 0.5 mol/L sulfuric acid TS, sonicate for 20 minutes, add sodium 1-heptanesulfonate solution (1 in 5000) adjusted to pH 3.0 with 0.5 mol/L sulfuric acid TS to exactly V mL so that each mL contains about 0.2 mg of cetirizine hydrochloride ($C_{21}H_{25}ClN_2O_3 \cdot 2HCl$), and filter through a membrane filter with a pore size not exceeding $0.45 \mu\text{m}$. Discard the first 3 mL of the filtrate, pipet 5 mL of the subsequent filtrate, add exactly 2 mL of the internal standard solution, add acetonitrile to make 10 mL, and use this solution as the sample solution. Then, proceed as directed in the Assay.

$$\begin{aligned} & \text{Amount (mg) of cetirizine hydrochloride} \\ & (C_{21}H_{25}ClN_2O_3 \cdot 2HCl) \\ & = M_S \times Q_T/Q_S \times V/100 \end{aligned}$$

M_S : Amount (mg) of cetirizine hydrochloride for assay taken

Internal standard solution—A solution of propyl parahydroxybenzoate in the mobile phase (1 in 1000).

Dissolution <6.10> When the test is performed at 50 revolutions per minute according to the Paddle method, using 900 mL of water as the dissolution medium, the dissolution rates in 15 minutes of 5-mg tablet and in 30 minutes of 10-mg tablet are not less than 85% and not less than 80%, respectively.

Start the test with 1 tablet of Cetirizine Hydrochloride Tablets, withdraw not less than 20 mL of the medium at the specified minute after starting the test, and filter through a membrane filter with a pore size not exceeding $0.45 \mu\text{m}$. Discard not less than 10 mL of the first filtrate, pipet V mL of the subsequent filtrate, add water to make exactly V' mL so that each mL contains about $5.6 \mu\text{g}$ of cetirizine hydrochloride ($C_{21}H_{25}ClN_2O_3 \cdot 2HCl$), and use this solution as the sample solution. Separately, weigh accurately about 28 mg of cetirizine hydrochloride for assay, previously dried in vacuum at 60°C for 3 hours, and dissolve in water to make exactly 100 mL. Pipet 2 mL of this solution, add water to make exactly 100 mL, and use this solution as the standard solution. Determine the absorbances, A_T and A_S , at 230 nm

of the sample solution and the standard solution as directed under Ultraviolet-visible Spectrophotometry <2.24>.

$$\begin{aligned} & \text{Dissolution rate (\%)} \text{ with respect to the labeled amount} \\ & \text{of cetirizine hydrochloride } (C_{21}H_{25}ClN_2O_3 \cdot 2HCl) \\ & = M_S \times A_T/A_S \times V'/V \times 1/C \times 18 \end{aligned}$$

M_S : Amount (mg) of cetirizine hydrochloride for assay taken

C : Labeled amount (mg) of cetirizine hydrochloride ($C_{21}H_{25}ClN_2O_3 \cdot 2HCl$) in 1 tablet

Assay Weigh accurately not less than 20 Cetirizine Hydrochloride Tablets, and powder. Weigh accurately a portion of the powder, equivalent to about 10 mg of cetirizine hydrochloride ($C_{21}H_{25}ClN_2O_3 \cdot 2HCl$), add 40 mL of sodium 1-heptanesulfonate solution (1 in 5000) adjusted to pH 3.0 with 0.5 mol/L sulfuric acid TS, treat with ultrasonic waves for 20 minutes, add sodium 1-heptanesulfonate solution (1 in 5000) adjusted to pH 3.0 with 0.5 mol/L sulfuric acid TS, to make exactly 50 mL, and filter this solution through a membrane filter with a pore size not exceeding $0.45 \mu\text{m}$. Discard the first 3 mL of the filtrate, pipet 5 mL of the subsequent filtrate, add exactly 2 mL of the internal standard solution, add acetonitrile to make exactly 10 mL, and use this solution as the sample solution. Separately, weigh accurately about 20 mg of cetirizine hydrochloride for assay, previously dried in vacuum at 60°C for 3 hours, and add sodium 1-heptanesulfonate solution (1 in 5000) adjusted to pH 3.0 with 0.5 mol/L sulfuric acid TS, to make exactly 100 mL. Pipet 5 mL of this solution, add exactly 2 mL of the internal standard solution, add acetonitrile to make 10 mL, and use this solution as the standard solution. Perform the test with 20 μL each of the sample solution and standard solution as directed under Liquid Chromatography <2.01> according to the following conditions, and calculate the ratios, Q_T and Q_S , of the peak area of cetirizine to that of the internal standard.

$$\begin{aligned} & \text{Amount (mg) of cetirizine hydrochloride} \\ & (C_{21}H_{25}ClN_2O_3 \cdot 2HCl) \\ & = M_S \times Q_T/Q_S \times 1/2 \end{aligned}$$

M_S : Amount (mg) of cetirizine hydrochloride for assay taken

Internal standard solution—A solution of propyl parahydroxybenzoate in the mobile phase (1 in 1000).

Operating conditions—

Detector: An ultraviolet absorption photometer (wavelength: 230 nm).

Column: A stainless steel column 4.0 mm in inside diameter and 25 cm in length, packed with octylsilylated silica gel for liquid chromatography ($5 \mu\text{m}$ in particle diameter).

Column temperature: A constant temperature of about 25°C .

Mobile phase: A mixture of a solution of sodium 1-heptanesulfonate (1 in 2900) and acetonitrile (29:21), adjusted to pH 3.0 with 0.5 mol/L sulfuric acid TS.

Flow rate: Adjust so that the retention time of cetirizine is about 5 minutes.

System suitability—

System performance: When the procedure is run with 20 μL of the standard solution under the above operating conditions, cetirizine and the internal standard are eluted in this order with the resolution between these peaks being not less than 7.

System repeatability: When the test is repeated 6 times with 20 μL of the standard solution under the above operating conditions, the relative standard deviation of the ratio of

the peak area of cetirizine to that of the internal standard is not more than 1.0%.

Containers and storage Containers—Well-closed containers.

Cetotiamine Hydrochloride Hydrate

セトチアミン塩酸塩水和物

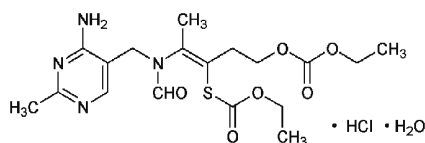

$C_{18}H_{26}N_4O_6S \cdot HCl \cdot H_2O$: 480.96
(3*Z*)-4-[*N*-[(4-Amino-2-methylpyrimidin-5-yl)methyl]-*N*-formylamino]-3-(ethoxycarbonylsulfanyl)pent-3-enyl ethyl carbonate monohydrochloride monohydrate
[616-96-6, anhydride]

Cetotiamine Hydrochloride Hydrate contains not less than 98.0% and not more than 102.0% of cetotiamine hydrochloride ($C_{18}H_{26}N_4O_6S \cdot HCl$: 462.95), calculated on the anhydrous basis.

Description Cetotiamine Hydrochloride Hydrate occurs as white, crystals or crystalline powder. It is odorless or has a faint characteristic odor.

It is freely soluble in water and in ethanol (99.5).

It dissolves in 0.01 mol/L hydrochloric acid TS.

Melting point: about 132°C (with decomposition).

Identification (1) Determine the absorption spectrum of a solution of Cetotiamine Hydrochloride Hydrate in 0.01 mol/L hydrochloric acid TS (1 in 50,000) as directed under Ultraviolet-visible Spectrophotometry <2.24>, and compare the spectrum with the Reference Spectrum or the spectrum of a solution of Cetotiamine Hydrochloride RS prepared in the same manner as the sample solution: both spectra exhibit similar intensities of absorption at the same wavelengths.

(2) Determine the infrared absorption spectrum of Cetotiamine Hydrochloride Hydrate as directed in the potassium bromide disk method under Infrared Spectrophotometry <2.25>, and compare the spectrum with the Reference Spectrum or the spectrum of Cetotiamine Hydrochloride RS: both spectra exhibit similar intensities of absorption at the same wave numbers.

(3) A solution of Cetotiamine Hydrochloride Hydrate (1 in 50) responds to Qualitative Tests <1.09> for chloride.

Purity (1) Clarity and color of solution—A solution obtained by dissolving 1.0 g of Cetotiamine Hydrochloride Hydrate in 10 mL of water is clear and has no more color than the following control solution.

Control solution: Mix exactly 1.5 mL of Cobalt (II) Chloride CS, exactly 36 mL of Iron (III) Chloride CS and exactly 12.5 mL of diluted dilute hydrochloric acid (1 in 10). Pipet 1 mL of this mixture, and add diluted dilute hydrochloric acid (1 in 10) to make exactly 100 mL.

(2) Heavy metals <1.07>—Proceed with 1.0 g of Cetotiamine Hydrochloride Hydrate according to Method 1, and perform the test. Prepare the control solution with 2.0 mL of Standard Lead Solution (not more than 20 ppm).

(3) Related substances—Dissolve 50 mg of Cetotiamine Hydrochloride Hydrate in 50 mL of the mobile phase, and use this solution as the sample solution. Pipet 1 mL of the

sample solution, add the mobile phase to make exactly 200 mL, and use this solution as the standard solution. Perform the test with exactly 10 μL each of the sample solution and standard solution as directed under Liquid Chromatography <2.01> according to the following conditions, and determine each peak area by the automatic integration method: the area of the peak other than cetotiamine obtained from the sample solution is not larger than the peak area of cetotiamine from the standard solution, and the total area of the peaks other than cetotiamine from the sample solution is not larger than 2 times the peak area of cetotiamine from the standard solution.

Operating conditions—

Detector, column, column temperature, mobile phase, and flow rate: Proceed as directed in the operating conditions in the Assay.

Time span of measurement: About 3 times as long as the retention time of cetotiamine, beginning after the solvent peak.

System suitability—

Test for required detectability: To exactly 2 mL of the standard solution add the mobile phase to make exactly 20 mL. Confirm that the peak area of cetotiamine obtained with 10 μL of this solution is equivalent to 7 to 13% of that with 10 μL of the standard solution.

System performance: When the procedure is run with 10 μL of the standard solution under the above operating conditions, the number of theoretical plates and the symmetry factor of the peak of cetotiamine are not less than 3000 and 0.7 – 1.0, respectively.

System repeatability: When the test is repeated 6 times with 10 μL of the standard solution under the above operating conditions, the relative standard deviation of the peak area of cetotiamine is not more than 2.0%.

Water <2.48> 3.0 – 5.0% (40 mg, coulometric titration).

Residue on ignition <2.44> Not more than 0.2% (1 g).

Assay Weigh accurately about 30 mg each of Cetotiamine Hydrochloride Hydrate and Cetotiamine Hydrochloride RS (separately determine the water <2.48> in the same manner as Cetotiamine Hydrochloride Hydrate), add exactly 10 mL each of the internal standard solution, then add a mixture of water and methanol (1:1) to make 50 mL. To 2 mL each of these solutions add a mixture of water and methanol (1:1) to make 10 mL, and use these solutions as the sample solution and the standard solution, respectively. Perform the test with 5 μL each of the sample solution and standard solution as directed under Liquid Chromatography <2.01> according to the following conditions, and calculate the ratios, Q_T and Q_S , of the peak area of cetotiamine to that of the internal standard.

$$\begin{aligned} & \text{Amount (mg) of cetotiamine hydrochloride} \\ & (C_{18}H_{26}N_4O_6S \cdot HCl) \\ & = M_S \times Q_T / Q_S \end{aligned}$$

M_S : Amount (mg) of Cetotiamine Hydrochloride RS taken, calculated on the anhydrous basis

Internal standard solution—A solution of propyl parahydroxybenzoate in a mixture of water and methanol (1:1) (1 in 800).

Operating conditions—

Detector: An ultraviolet absorption photometer (wavelength: 245 nm).

Column: A stainless steel column 4.6 mm in inside diameter and 15 cm in length, packed with octadecylsilanized silica gel for liquid chromatography (5 μm in particle diameter).

Column temperature: A constant temperature of about 25°C.

Mobile phase: Dissolve 1.0 g of sodium 1-heptanesulfonate in diluted acetic acid (100) (1 in 100) to make 1000 mL. To 1 volume of this solution add 1 volume of methanol.

Flow rate: Adjust so that the retention time of cetotiamine is about 10 minutes.

System suitability—

System performance: When the procedure is run with 5 µL of the standard solution under the above operating conditions, cetotiamine and the internal standard are eluted in this order with the resolution between these peaks being not less than 5.

System repeatability: When the test is repeated 6 times with 5 µL of the standard solution under the above operating conditions, the relative standard deviation of the ratio of the peak area of cetotiamine to that of the internal standard is not more than 1.0%.

Containers and storage Containers—Tight containers.

Cetraxate Hydrochloride

セトラキサート塩酸塩

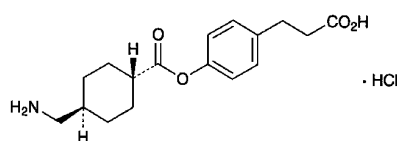

$C_{17}H_{23}NO_4 \cdot HCl$: 341.83

3-[4-[*trans*-4-(Aminomethyl)cyclohexylcarbonyloxy]-phenyl]propanoic acid monohydrochloride
[27724-96-5]

Cetraxate Hydrochloride, when dried, contains not less than 98.5% of cetraxate hydrochloride ($C_{17}H_{23}NO_4 \cdot HCl$).

Description Cetraxate Hydrochloride occurs as white, crystals or crystalline powder.

It is soluble in methanol, sparingly soluble in water and in ethanol (95), and practically insoluble in diethyl ether.

Melting point: about 236°C (with decomposition).

Identification (1) Determine the absorption spectrum of a solution of Cetraxate Hydrochloride in methanol (1 in 2500) as directed under Ultraviolet-visible Spectrophotometry <2.24>, and compare the spectrum with the Reference Spectrum: both spectra exhibit similar intensities of absorption at the same wavelengths.

(2) Dissolve 0.5 g of Cetraxate Hydrochloride in 5 mL of a mixture of water and 2-propanol (1:1) by warming, cool to below 25°C. Filter, dry the formed crystals in vacuum for 4 hours, and further dry at 105°C for 1 hour. Determine the infrared absorption spectrum of the dried matter as directed in the potassium chloride disk method under Infrared Spectrophotometry <2.25>, and compare the spectrum with the Reference Spectrum: both spectra exhibit similar intensities of absorption at the same wave numbers.

(3) A solution of Cetraxate Hydrochloride (1 in 100) responds to Qualitative Tests <1.09> (2) for chloride.

Purity (1) Heavy metals <1.07>—Proceed with 2.0 g of Cetraxate Hydrochloride according to Method 2, and perform the test. Prepare the control solution with 2.0 mL of Standard Lead Solution (not more than 10 ppm).

(2) Arsenic <1.11>—Prepare the test solution with 1.0 g

of Cetraxate Hydrochloride according to Method 3, and perform the test with a solution of magnesium nitrate hexahydrate in ethanol (95) (1 in 5) (not more than 2 ppm).

(3) *cis* Isomer—Dissolve 0.10 g of Cetraxate Hydrochloride in 10 mL of water, and use this solution as the sample solution. To exactly 5 mL of the sample solution add water to make exactly 100 mL. To exactly 2 mL of this solution add water to make exactly 50 mL, and use this solution as the standard solution. Perform the test with exactly 10 µL each of the sample solution and standard solution as directed under Liquid Chromatography <2.01> according to the following conditions. Determine each peak area of both solutions by the automatic integration method: the area of the peak, having the relative retention time 1.3 to 1.6 to cetraxate from the sample solution is not larger than the peak area of cetraxate from the standard solution.

Operating conditions—

Detector: An ultraviolet absorption photometer (wavelength: 220 nm).

Column: A stainless steel column 6 mm in inside diameter and 15 cm in length, packed with octadecylsilanized silica gel for liquid chromatography (5 µm in particle diameter).

Column temperature: A constant temperature of about 25°C.

Mobile phase: Adjust the pH of a mixture of water, methanol and 0.5 mol/L ammonium acetate TS (15:10:4) to 6.0 with acetic acid (31).

Flow rate: Adjust so that the retention time of cetraxate is about 10 minutes.

System suitability—

System performance: Dissolve 0.02 g of Cetraxate Hydrochloride and 0.01 g of phenol in 100 mL of water. To 2 mL of this solution add water to make 20 mL. When the procedure is run with 10 µL of this solution under the above operating conditions, cetraxate and phenol are eluted in this order with the resolution between these peaks being not less than 5.

System repeatability: When the test is repeated 6 times with 10 µL of the standard solution under the above operating conditions, the relative standard deviation of the peak area of cetraxate is not more than 2.0%.

(4) 3-(*p*-Hydroxyphenyl)propionic acid—To 0.10 g of Cetraxate Hydrochloride add exactly 2 mL of the internal standard solution and methanol to make 10 mL, and use this solution as the sample solution. Separately, dissolve 25 mg of 3-(*p*-hydroxyphenyl)propionic acid in methanol to make exactly 100 mL. To exactly 2 mL of this solution add exactly 2 mL of the internal standard solution and methanol to make 10 mL, and use this solution as the standard solution. Perform the test with 10 µL each of the sample solution and standard solution as directed under Liquid Chromatography <2.01> according to the following conditions, and calculate the ratios, Q_T and Q_S , of the peak area of 3-(*p*-hydroxyphenyl)propionic acid to that of the internal standard: Q_T is not larger than Q_S .

Internal standard solution—A solution of caffeine in methanol (1 in 4000).

Operating conditions—

Detector: An ultraviolet absorption photometer (wavelength: 230 nm).

Column: A stainless steel column 6 mm in inside diameter and 15 cm in length, packed with octadecylsilanized silica gel for liquid chromatography (5 µm in particle diameter).

Column temperature: A constant temperature of about 40°C.

Mobile phase: Adjust the pH of a mixture of water, methanol and 0.5 mol/L ammonium acetate TS (15:5:2) to 5.5

with acetic acid (31).

Flow rate: Adjust so that the retention time of 3-(*p*-hydroxyphenyl)propionic acid is about 7 minutes.

System suitability—

System performance: When the procedure is run with 10 μ L of the standard solution under the above operating conditions, 3-(*p*-hydroxyphenyl)propionic acid and the internal standard are eluted in this order with the resolution between these peaks being not less than 5.

System repeatability: When the test is repeated 6 times with 10 μ L of the standard solution under the above operating conditions, the relative standard deviation of the ratio of the peak area of 3-(*p*-hydroxyphenyl)propionic acid to that of the internal standard is not more than 1.0%.

(5) Related substances—Dissolve 0.10 g of Cetraxate Hydrochloride in 10 mL of methanol, and use this solution as the sample solution. Pipet 1 mL of the sample solution, add methanol to make exactly 100 mL, and use this solution as the standard solution. Perform the test with these solutions as directed under Thin-layer Chromatography <2.03>. Spot 5 μ L each of the sample solution and standard solution on a plate of silica gel for thin-layer chromatography. Develop the plate with a mixture of chloroform, methanol and acetic acid (100) (20:4:3) to a distance of about 10 cm, and air-dry the plate. Spray evenly ninhydrin TS on the plate, and heat the plate at 90°C for 10 minutes: the spots other than the principal spot obtained from the sample solution are not more intense than the spot from the standard solution.

Loss on drying <2.41> Not more than 0.5% (0.5 g, 105°C, 3 hours).

Residue on ignition <2.44> Not more than 0.1% (1 g).

Assay Weigh accurately about 0.5 g of Cetraxate Hydrochloride, previously dried, dissolve in 100 mL of water, and adjust the pH of this solution to between 7.0 and 7.5 with dilute sodium hydroxide TS. To this solution add 10 mL of formaldehyde solution, stir for about 5 minutes, and titrate <2.50> with 0.1 mol/L sodium hydroxide VS by taking over about 20 minutes (potentiometric titration). Perform a blank determination in the same manner, and make any necessary correction.

Each mL of 0.1 mol/L sodium hydroxide VS
= 34.18 mg of $C_{17}H_{23}NO_4 \cdot HCl$

Containers and storage Containers—Tight containers.

Chenodeoxycholic Acid

ケノデオキシコール酸

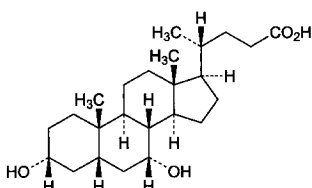

$C_{24}H_{40}O_4$: 392.57

3 α ,7 α -Dihydroxy-5 β -cholan-24-oic acid
[474-25-9]

Chenodeoxycholic Acid, when dried, contains not less than 98.0% and not more than 101.0% of chenodeoxycholic acid ($C_{24}H_{40}O_4$).

Description Chenodeoxycholic Acid occurs as white, crys-

tals, crystalline powder or powder.

It is freely soluble in methanol and in ethanol (99.5), soluble in acetone, and practically insoluble in water.

Identification Determine the infrared absorption spectrum of Chenodeoxycholic Acid, previously dried, as directed in the potassium bromide disk method under Infrared Spectrophotometry <2.25>, and compare the spectrum with the Reference Spectrum: both spectra exhibit similar intensities of absorption at the same wave numbers.

Optical rotation <2.49> $[\alpha]_D^{20}$: +11.0 – +13.0° (after drying, 0.4 g, ethanol (99.5), 20 mL, 100 mm).

Melting point <2.60> 164 – 169°C

Purity (1) Chloride <1.03>—Dissolve 0.36 g of Chenodeoxycholic Acid in 30 mL of methanol, add 10 mL of dilute nitric acid and water to make 50 mL, and perform the test with this solution. Prepare the control solution as follows: To 1.0 mL of 0.01 mol/L hydrochloric acid VS add 30 mL of methanol, 10 mL of dilute nitric acid and water to make 50 mL (not more than 0.1%).

(2) Heavy metals <1.07>—Proceed with 1.0 g of Chenodeoxycholic Acid according to Method 4, and perform the test. Prepare the control solution with 2.0 mL of Standard Lead Solution (not more than 20 ppm).

(3) Barium—To 2.0 g of Chenodeoxycholic Acid add 100 mL of water, and boil for 2 minutes. To this solution add 2 mL of hydrochloric acid, boil for 2 minutes, filter after cooling, and wash the filter with water until to get 100 mL of the filtrate. To 10 mL of the filtrate add 1 mL of dilute sulfuric acid: no turbidity appears.

(4) Related substances—Dissolve 0.20 g of Chenodeoxycholic Acid in a mixture of acetone and water (9:1) to make exactly 10 mL, and use this solution as the sample solution. Separately, dissolve 10 mg of lithocholic acid for thin-layer chromatography in the mixture of acetone and water (9:1) to make exactly 10 mL. Pipet 2 mL of this solution, add the mixture of acetone and water (9:1) to make exactly 100 mL, and use this solution as the standard solution (1). Separately, dissolve 10 mg of ursodeoxycholic acid in the mixture of acetone and water (9:1) to make exactly 100 mL, and use this solution as the standard solution (2). Separately, dissolve 10 mg of cholic acid for thin-layer chromatography in the mixture of acetone and water (9:1) to make exactly 100 mL, and use this solution as the standard solution (3). Pipet 1 mL of the sample solution, and add the mixture of acetone and water (9:1) to make exactly 20 mL. Pipet 0.5 mL, 1 mL, 2 mL, 3 mL and 5 mL of this solution, add the mixture of acetone and water (9:1) to each of them to make exactly 50 mL, and designate these solutions as standard solution A, standard solution B, standard solution C, standard solution D and standard solution E, respectively. Perform the test with these solutions as directed under Thin-layer Chromatography <2.03>. Spot 5 μ L each of the sample solution, standard solutions (1), (2), (3) and standard solutions A, B, C, D and E on a plate of silica gel for thin-layer chromatography. Develop the plate with a mixture of 4-methyl-2-pentanone, toluene and formic acid (16:6:1) to a distance of about 15 cm, air-dry the plate, and further dry at 120°C for 30 minutes. Immediately, spray evenly a solution of phosphomolybdic acid *n*-hydrate in ethanol (95) (1 in 5) on the plate, and heat the plate at 120°C for 2 to 3 minutes: the spot corresponding to the spot obtained from the standard solution (1) is not more intense than the spot from the standard solution (1), the spot corresponding to the spot from the standard solution (2) is not more intense than the spot from the standard solution (2), and the spot corresponding to the spot from the stand-

ard solution (3) is not more intense than the spot from the standard solution (3). As compared to the spots with the standard solutions A, B, C, D and E, the spots other than the principal spot and the spots mentioned above from the sample solution are not more intense than the spot from the standard solution E, and the total amount of them is not more than 1.5%.

Loss on drying <2.41> Not more than 1.5% (1 g, 105°C, 3 hours).

Residue on ignition <2.44> Not more than 0.1% (1 g).

Assay Weigh accurately about 0.5 g of Chenodeoxycholic Acid, previously dried, dissolve in 40 mL of ethanol (95) and 20 mL of water, and titrate <2.50> with 0.1 mol/L sodium hydroxide VS (potentiometric titration). Perform a blank determination in the same manner, and make any necessary correction.

Each mL of 0.1 mol/L sodium hydroxide VS
= 39.26 mg of C₂₄H₄₀O₄

Containers and storage Containers—Tight containers.

Chloral Hydrate

抱水クロラール

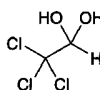

C₂H₃Cl₃O₂: 165.40
2,2,2-Trichloroethane-1,1-diol
[302-17-0]

Chloral Hydrate contains not less than 99.5% of chloral hydrate (C₂H₃Cl₃O₂).

Description Chloral Hydrate occurs as colorless crystals. It has a pungent odor and an acrid, slightly bitter taste.

It is very soluble in water, and freely soluble in ethanol (95) and in diethyl ether.

It slowly volatilizes in air.

Identification (1) Dissolve 0.2 g of Chloral Hydrate in 2 mL of water, and add 2 mL of sodium hydroxide TS: the turbidity is produced, and it separates into two clear layers by warming.

(2) Heat 0.2 g of Chloral Hydrate with 3 drops of aniline and 3 drops of sodium hydroxide TS: the disagreeable odor of phenylisocyanide (poisonous) is perceptible.

Purity (1) Clarity and color of solution—Dissolve 1.0 g of Chloral Hydrate in 2 mL of water: the solution is clear and colorless.

(2) Acidity—Dissolve 0.20 g of Chloral Hydrate in 2 mL of water, and add 1 drop of methyl orange TS: a yellow color develops.

(3) Chloride <1.03>—Perform the test with 1.0 g of Chloral Hydrate. Prepare the control solution with 0.30 mL of 0.01 mol/L hydrochloric acid VS (not more than 0.011%).

(4) Chloral alcoholate—Warm 1.0 g of Chloral Hydrate with 10 mL of sodium hydroxide TS, filter the upper layer, add iodine TS to the filtrate until a yellow color develops, and allow the solution to stand for 1 hour: no yellow precipitate is produced.

(5) Benzene—Warm the solution obtained in (1) with 3 mL of water: no odor of benzene is perceptible.

Residue on ignition <2.44> Not more than 0.1% (1 g).

Assay Weigh accurately about 4 g of Chloral Hydrate in a glass-stoppered flask, add 10 mL of water and exactly 40 mL of 1 mol/L sodium hydroxide VS, and allow the mixture to stand for exactly 2 minutes. Titrate <2.50> the excess sodium hydroxide immediately with 0.5 mol/L sulfuric acid VS (indicator: 2 drops of phenolphthalein TS). Perform a blank determination in the same manner, and make any necessary correction.

Each mL of 1 mol/L sodium hydroxide VS
= 165.4 mg of C₂H₃Cl₃O₂

Containers and storage Containers—Tight containers.

Chloramphenicol

クロラムフェニコール

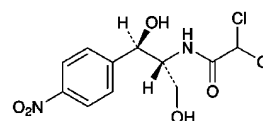

C₁₁H₁₂Cl₂N₂O₅: 323.13
2,2-Dichloro-*N*-[(1*R*,2*R*)-1,3-dihydroxy-1-(4-nitrophenyl)propan-2-yl]acetamide
[56-75-7]

Chloramphenicol contains not less than 980 μg (potency) and not more than 1020 μg (potency) per mg, calculated on the dried basis. The potency of Chloramphenicol is expressed as mass (potency) of chloramphenicol (C₁₁H₁₂Cl₂N₂O₅).

Description Chloramphenicol occurs as white to yellow-white, crystals or crystalline powder.

It is freely soluble in methanol and in ethanol (99.5), and slightly soluble in water.

Identification (1) Determine the absorption spectrum of the sample solution obtained in the Assay as directed under Ultraviolet-visible Spectrophotometry <2.24>, and compare the spectrum with the Reference Spectrum or the spectrum of a solution of Chloramphenicol RS prepared in the same manner as the sample solution: both spectra exhibit similar intensities of absorption at the same wavelengths.

(2) Determine the infrared absorption spectrum of Chloramphenicol as directed in the potassium bromide disk method under Infrared Spectrophotometry <2.25>, and compare the spectrum with the Reference Spectrum or the spectrum of Chloramphenicol RS: both spectra exhibit similar intensities of absorption at the same wave numbers.

Optical rotation <2.49> [α]_D²⁰: +18.5 – +21.5° (1.25 g, ethanol (99.5), 25 mL, 100 mm).

Melting point <2.60> 150 – 155°C

Purity (1) Heavy metals <1.07>—Proceed with 1.0 g of Chloramphenicol according to Method 2, and perform the test. Prepare the control solution with 2.5 mL of Standard Lead Solution (not more than 25 ppm).

(2) Related substances—Dissolve 0.10 g of Chloramphenicol in 10 mL of methanol, and use this solution as the sample solution. Pipet 1 mL of the sample solution, add methanol to make exactly 100 mL, and use this solution as the standard solution (1). Pipet 10 mL of the standard solution (1), add methanol to make exactly 20 mL, and use this

solution as the standard solution (2). Perform the test with these solutions as directed under Thin-layer Chromatography <2.03>. Spot 20 μL each of the sample solution and standard solutions (1) and (2) on a plate of silica gel with fluorescent indicator for thin-layer chromatography, develop the plate with a mixture of ethyl acetate, methanol and acetic acid (100) (10:1:1) to a distance of about 15 cm, and air-dry the plate. Examine under ultraviolet light (main wavelength: 254 nm): the spots other than the principal spot and the spot of the starting point obtained from the sample solution are not more intense than the spot from the standard solution (1), and the total amount of these spots from the sample solution is not more than 2.0%.

Loss on drying <2.41> Not more than 0.5% (1 g, 105°C, 3 hours).

Residue on ignition <2.44> Not more than 0.1% (1 g).

Assay Weigh accurately an amount of Chloramphenicol and Chloramphenicol RS, equivalent to about 50 mg (potency), dissolve each in 10 mL of methanol, and add water to make exactly 50 mL. Pipet 20 mL each of these solutions, and add water to make exactly 100 mL. Pipet 10 mL each of these solutions, add water to make exactly 100 mL, and use these solutions as the sample solution and standard solution. Determine the absorbances, A_T and A_S , of the sample solution and standard solution at 278 nm as directed under Ultraviolet-visible Spectrophotometry <2.24>.

Amount [μg (potency)] of chloramphenicol ($\text{C}_{11}\text{H}_{12}\text{Cl}_2\text{N}_2\text{O}_5$)
 $= M_S \times A_T / A_S \times 1000$

M_S : Amount [mg (potency)] of Chloramphenicol RS taken

Containers and storage Containers—Tight containers.

Chloramphenicol Palmitate

クロラムフェニコールパルミチン酸エステル

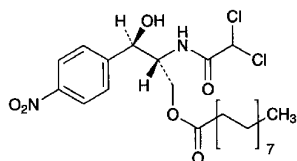

$\text{C}_{27}\text{H}_{42}\text{Cl}_2\text{N}_2\text{O}_6$; 561.54
 (2*R*,3*R*)-2-(Dichloroacetyl)amino-3-hydroxy-3-(4-nitrophenyl)propan-1-yl palmitate
 [530-43-8]

Chloramphenicol Palmitate contains not less than 558 μg (potency) and not more than 587 μg (potency) per mg, calculated on the dried basis. The potency of Chloramphenicol Palmitate is expressed as mass (potency) of chloramphenicol ($\text{C}_{11}\text{H}_{12}\text{Cl}_2\text{N}_2\text{O}_5$; 323.13).

Description Chloramphenicol Palmitate occurs as a white to grayish white, crystalline powder.

It is freely soluble in acetone, sparingly soluble in methanol and in ethanol (99.5), and practically insoluble in water.

Identification (1) Determine the absorption spectrum of a solution of Chloramphenicol Palmitate in ethanol (99.5) (1 in 33,000) as directed under Ultraviolet-visible Spectrophotometry <2.24>, and compare the spectrum with the Reference Spectrum or the spectrum of a solution of Chloramphenicol Palmitate RS prepared in the same manner as the

sample solution: both spectra exhibit similar intensities of absorption at the same wavelengths.

(2) Dissolve 5 mg each of Chloramphenicol Palmitate and Chloramphenicol Palmitate RS in 1 mL of acetone, and use these solutions as the sample solution and standard solution. Perform the test with these solutions as directed under Thin-layer Chromatography <2.03>. Spot 5 μL each of the sample solution and standard solution on a plate of silica gel with fluorescent indicator for thin-layer chromatography. Develop the plate with a mixture of acetone and cyclohexane (1:1) to a distance of about 10 cm, and air-dry the plate. Examine under ultraviolet light (main wavelength: 254 nm): the principal spot obtained from the sample solution has the same R_f value as the spot from the standard solution.

Optical rotation <2.49> $[\alpha]_D^{25}$: +21 – +25° (1 g calculated on the dried basis, ethanol (99.5), 20 mL, 100 mm).

Melting point <2.60> 91 – 96°C

Purity (1) Heavy metals <1.07>—Proceed with 1.0 g of Chloramphenicol Palmitate according to Method 4, and perform the test. Prepare the control solution with 2.0 mL of Standard Lead Solution (not more than 20 ppm).

(2) Arsenic <1.11>—Prepare the test solution with 1.0 g of Chloramphenicol Palmitate according to Method 3, and perform the test (not more than 2 ppm).

(3) Related substances—Dissolve 50 mg of Chloramphenicol Palmitate in 50 mL of methanol, and use this solution as the sample solution. Pipet 1 mL of the sample solution, add methanol to make exactly 100 mL, and use this solution as the standard solution. Perform the test with exactly 20 μL each of the sample solution and standard solution as directed under Liquid Chromatography <2.01> according to the following conditions. The test should be performed within 30 minutes after the sample solution and standard solution are prepared. Determine each peak area by the automatic integration method: the total area of the peaks other than the peak of chloramphenicol palmitate obtained from the sample solution is not larger than 3.5 times the peak area of chloramphenicol palmitate from the standard solution. For the peak areas for chloramphenicol, having the relative retention time of about 0.5 to chloramphenicol palmitate, and for chloramphenicol dipalmitate, having the relative retention time of about 5.0, multiply their correction factors, 0.5 and 1.4, respectively.

Operating conditions—

Detector: An ultraviolet absorption photometer (wavelength: 270 nm).

Column: A stainless steel column 6.0 mm in inside diameter and 15 cm in length, packed with octadecylsilanized silica gel for liquid chromatography (5 μm in particle diameter).

Column temperature: A constant temperature of about 20°C.

Mobile phase: Methanol.

Flow rate: Adjust so that the retention time of chloramphenicol palmitate is about 5 minutes.

Time span of measurement: About 6 times as long as the retention time of chloramphenicol palmitate.

System suitability—

Test for required detectability: Dissolve 50 mg of Chloramphenicol Palmitate in 50 mL of methanol. To 1 mL of this solution, add methanol to make 100 mL, and use this solution as the solution for system suitability test. Pipet 5 mL of the solution for system suitability test, and add methanol to make exactly 50 mL. Confirm that the peak area of chloramphenicol palmitate obtained with 20 μL of this solution is equivalent to 7 to 13% of that with 20 μL of the solution

for system suitability test.

System performance: When the procedure is run with 20 μL of the solution for system suitability test under the above operating conditions, the number of theoretical plates of the peak of chloramphenicol palmitate is not less than 5000.

System repeatability: When the test is repeated 6 times with 20 μL of the solution for system suitability test under the above operating conditions, the relative standard deviation of the peak area of chloramphenicol palmitate is not more than 1.0%.

Loss on drying <2.41> Not more than 1.0% (1 g, reduced pressure not exceeding 0.67 kPa, 60°C, 3 hours).

Assay Weigh accurately an amount of Chloramphenicol Palmitate and Chloramphenicol Palmitate RS, equivalent to about 37 mg (potency), dissolve each in 40 mL of methanol and 1 mL of acetic acid (100), and add methanol to make exactly 50 mL. Pipet 10 mL each of these solutions, add the mobile phase to make exactly 25 mL, and use these solutions as the sample solution and standard solution. Perform the test with exactly 10 μL each of the sample solution and standard solution as directed under Liquid Chromatography <2.01> according to the following conditions, and determine the peak areas, A_T and A_S , of chloramphenicol palmitate in each solution.

Amount [μg (potency)] of chloramphenicol ($\text{C}_{11}\text{H}_{12}\text{Cl}_2\text{N}_2\text{O}_5$)
 $= M_S \times A_T / A_S \times 1000$

M_S : Amount [mg (potency)] of Chloramphenicol Palmitate RS taken

Operating conditions—

Detector: An ultraviolet absorption photometer (wavelength: 280 nm).

Column: A stainless steel column 3.9 mm in inside diameter and 30 cm in length, packed with octadecylsilanized silica gel for liquid chromatography (10 μm in particle diameter).

Column temperature: A constant temperature of about 40°C.

Mobile phase: A mixture of methanol, water and acetic acid (100) (172:27:1).

Flow rate: Adjust so that the retention time of chloramphenicol palmitate is about 7 minutes.

System suitability—

System performance: When the procedure is run with 10 μL of the standard solution under the above operating conditions, the number of theoretical plates of the peak of chloramphenicol palmitate is not less than 2400.

System repeatability: When the test is repeated 6 times with 10 μL of the standard solution under the above operating conditions, the relative standard deviation of the peak area of chloramphenicol palmitate is not more than 1.0%.

Containers and storage Containers—Tight containers.

Storage—Light-resistant.

Chloramphenicol Sodium Succinate

クロラムフェニコールコハク酸エステルナトリウム

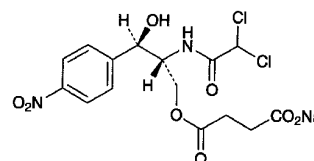

$\text{C}_{15}\text{H}_{15}\text{Cl}_2\text{N}_2\text{NaO}_8$; 445.18

Monosodium (2*R*,3*R*)-2-(dichloroacetyl)amino-3-hydroxy-3-(4-nitrophenyl)propan-1-yl succinate
 [982-57-0]

Chloramphenicol Sodium Succinate contains not less than 711 μg (potency) and not more than 740 μg (potency) per mg, calculated on the anhydrous basis. The potency of Chloramphenicol Sodium Succinate is expressed as mass (potency) of chloramphenicol ($\text{C}_{11}\text{H}_{12}\text{Cl}_2\text{N}_2\text{O}_5$; 323.13).

Description Chloramphenicol Sodium Succinate occurs as white to yellowish white, crystals or crystalline powder.

It is very soluble in water, and freely soluble in methanol and in ethanol (99.5).

It is hygroscopic.

Identification (1) Determine the absorption spectrum of a solution of Chloramphenicol Sodium Succinate (1 in 50,000) as directed under Ultraviolet-visible Spectrophotometry <2.24>, and compare the spectrum with the Reference Spectrum: both spectra exhibit similar intensities of absorption at the same wavelengths.

(2) Determine the infrared absorption spectrum of Chloramphenicol Sodium Succinate as directed in the potassium bromide disk method under Infrared Spectrophotometry <2.25>, and compare the spectrum with the Reference Spectrum: both spectra exhibit similar intensities of absorption at the same wave numbers.

(3) Chloramphenicol Sodium Succinate responds to Qualitative Tests <1.09> (1) for sodium salt.

Optical rotation <2.49> $[\alpha]_D^{25}$: +5 – +8° (1.25 g calculated on the anhydrous basis, water, 25 mL, 100 mm).

pH <2.54> The pH of a solution obtained by dissolving 1.4 g of Chloramphenicol Sodium Succinate in 5 mL of water is between 6.0 and 7.0.

Purity (1) Clarity and color of solution—Dissolve 1.0 g of Chloramphenicol Sodium Succinate in 10 mL of water: the solution is clear, and the absorbance at 420 nm of the solution determined as directed under Ultraviolet-visible Spectrophotometry <2.24> is not more than 0.30.

(2) Heavy metals <1.07>—Proceed with 1.0 g of Chloramphenicol Sodium Succinate according to Method 2, and perform the test. Prepare the control solution with 2.0 mL of Standard Lead Solution (not more than 20 ppm).

Water <2.48> Not more than 2.0% (1.0 g, volumetric titration, direct titration).

Assay Weigh accurately an amount of Chloramphenicol Sodium Succinate, equivalent to about 20 mg (potency), dissolve in water to make exactly 1000 mL, and use this solution as the sample solution. Separately, weigh accurately an amount of Chloramphenicol Succinate RS, equivalent to about 20 mg (potency), add about 50 mL of water to make a

suspension, and add gradually about 7 mL of 0.01 mol/L sodium hydroxide TS while stirring to adjust the pH to 7.0. To this solution add water to make exactly 1000 mL, and use this solution as the standard solution. Determine the absorbances, A_T and A_S , at 276 nm of the sample solution and standard solution as directed under Ultraviolet-visible Spectrophotometry <2.24>.

Amount [μg (potency)] of chloramphenicol ($\text{C}_{11}\text{H}_{12}\text{Cl}_2\text{N}_2\text{O}_5$)
 $= M_S \times A_T / A_S \times 1000$

M_S : Amount [mg (potency)] of Chloramphenicol Succinate RS taken

Containers and storage Containers—Hermetic containers.

Chloramphenicol and Colistin Sodium Methanesulfonate Ophthalmic Solution

クロラムフェニコール・コリスチンメタンサルホン酸ナトリウム点眼液

Chloramphenicol and Colistin Sodium Methanesulfonate Ophthalmic Solution is an aqueous ophthalmic preparation.

It contains not less than 90.0% and not more than 120.0% of the labeled potency of chloramphenicol ($\text{C}_{11}\text{H}_{12}\text{Cl}_2\text{N}_2\text{O}_5$; 323.13) and labeled Units of colistin A ($\text{C}_{53}\text{H}_{100}\text{N}_{16}\text{O}_{13}$; 1169.46).

Method of preparation Prepare as directed under Ophthalmic Liquids and Solutions, with Chloramphenicol and Colistin Sodium Methanesulfonate.

Description Chloramphenicol and Colistin Sodium Methanesulfonate Ophthalmic Solution is a clear, colorless to pale yellow liquid.

Identification (1) To a volume of Chloramphenicol and Colistin Sodium Methanesulfonate Ophthalmic Solution, equivalent to about 2.5 mg (potency) of Chloramphenicol, and add water to make 100 mL. Determine the absorption spectrum of this solution as directed under Ultraviolet-visible Spectrophotometry <2.24>, using water as a blank: it exhibits a maximum between 276 nm and 280 nm.

(2) To a volume of Chloramphenicol and Colistin Sodium Methanesulfonate Ophthalmic Solution, equivalent to about 5×10^5 Units of Colistin Sodium Methanesulfonate add 0.5 mL of ninhydrin TS, boil for 1 minute, and cool: a blue color develops.

Osmotic pressure ratio Being specified separately when the drug is granted approval based on the Law.

pH <2.54> 6.0 – 8.0

Foreign insoluble matter <6.11> It meets the requirement.

Insoluble particulate matter <6.08> It meets the requirement.

Sterility <4.06> Perform the test according to the Membrane filtration method: it meets the requirement.

Assay Perform the test according to the Cylinder-plate method as directed under Microbial Assay for Antibiotics <4.02> according to the following conditions.

(1) Chloramphenicol

(i) Test organism—*Kocuria rhizophila* ATCC 9341

(ii) Agar media for base layer and seed layer—Use the medium ii in 3) under (1) Agar media for seed and base layer.

(iii) Agar medium for transferring test organisms—Use the medium i in 2) under (2) Agar media for transferring test organisms.

(iv) Liquid medium for suspending test organisms—Use the medium (2) Liquid media for suspending test organisms of 3.2. Culture media.

(v) Standard solutions—Weigh accurately an amount of Chloramphenicol RS, equivalent to about 20 mg (potency), dissolve in 2 mL of ethanol (95), add phosphate buffer solution (pH 6.0) to make exactly 20 mL, and use this solution as the standard stock solution. Keep the standard stock solution at 15°C or below, and use within 30 days. Pipet a suitable amount of the standard stock solution before use, add phosphate buffer solution (pH 6.0) to make solutions so that each mL contains 100 μg (potency) and 25 μg (potency), and use these solutions as the high concentration standard solution and the low concentration standard solution, respectively.

(vi) Sample solutions—Weigh accurately an amount of Chloramphenicol and Colistin Sodium Methanesulfonate Ophthalmic Solution, equivalent to about 10 mg (potency) of Chloramphenicol, add phosphate buffer solution (pH 6.0) to make exactly 100 mL, and filter, if necessary. Pipet a suitable amount of this solution, add phosphate buffer solution (pH 6.0) to make solutions so that each mL contains 100 μg (potency) and 25 μg (potency), and use these solutions as the high concentration sample solution and the low concentration sample solution, respectively.

(2) Colistin Sodium Methanesulfonate

(i) Test organism—*Bordetella bronchiseptica* ATCC 4617

(ii) Agar medium for base layer—

Casein peptone 17.0 g

Sodium chloride 5.0 g

Glucose 2.5 g

Soybean peptone 3.0 g

Dipotassium hydrogen phosphate 2.0 g

Agar 20.0 g

Water 1000 mL

Mix all the ingredients, then add a suitable amount of sodium hydroxide TS so that the pH of the medium will be 7.2 to 7.3 after sterilization, and sterile.

(iii) Agar medium for seed layer—

Casein peptone 17.0 g

Glucose 2.5 g

Soybean peptone 3.0 g

Sodium chloride 5.0 g

Polysorbate 80 10.0 g

Dipotassium hydrogen phosphate 2.5 g

Agar 12.0 g

Water 1000 mL

Mix all the ingredients, then add a suitable amount of sodium hydroxide TS so that the pH of the medium will be 7.2 to 7.3 after sterilization, and sterile.

(iv) Agar medium for transferring test organisms—Use the medium i in 2) under (2) Agar media for transferring test organisms.

(v) Preparation of test organism and seeded agar layer—Cultivate the test organism on the slant of the agar medium for transferring test organism at 32 to 37°C for 16 to 24 hours. Subcultures at least three times. Cultivate the grown organism on the slant of the agar medium for transferring test organism at 32 to 37°C for 16 to 24 hours, add a suitable amount of water to the grown organism, and sus-

pend. Adjust the suspension so that the transmittance at 660 nm is 60% as directed under Ultraviolet-visible Spectrophotometry <2.24> using a spectrophotometer or a photoelectric photometer, and use this suspension as the test organism suspension. Keep the test organism suspension at 15°C or below, and use within 3 days. Before use, dissolve 0.13 mL of the test organism suspension, add it to 100 mL of agar medium for seed previously cooled at 48°C, mix thoroughly, and use this as the seeded agar layer.

(vi) Standard solutions—Weigh accurately an amount of Colistin Sodium Methanesulfonate RS, equivalent to about 1×10^6 Units, dissolve in phosphate buffer solution (pH 6.0) to make exactly 100 mL, and use this solution as the standard stock solution. Keep the standard stock solution at 10°C or below, and use within 7 days. Pipet a suitable amount of the standard stock solution before use, add phosphate buffer solution (pH 6.0) to make solutions so that each mL contains 1000 Units and 250 Units, and use these solutions as the high concentration standard solution and the low concentration standard solution, respectively.

(vii) Sample solutions—Weigh accurately an amount of Chloramphenicol and Colistin Sodium Methanesulfonate Ophthalmic Solution, equivalent to about 1×10^5 Units of Colistin Sodium Methanesulfonate, add phosphate buffer solution (pH 6.0) to make a solution so that each mL contains 1000 Units, and use this solution as the high concentration sample solution. Pipet 5 mL of the high concentration sample solution, add phosphate buffer solution (pH 6.0) to make a solution so that each mL contains 250 Units, and use this solution as the low concentration sample solution.

Containers and storage Containers—Tight containers.

Storage—At a temperature between 2°C and 8°C.

Chlordiazepoxide

クロルジアゼポキシド

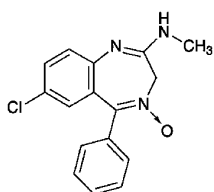

$C_{16}H_{14}ClN_3O$: 299.75

7-Chloro-2-methylamino-5-phenyl-3H-1,4-benzodiazepin-4-oxide
[58-25-3]

Chlordiazepoxide, when dried, contains not less than 98.5% of chlordiazepoxide ($C_{16}H_{14}ClN_3O$).

Description Chlordiazepoxide occurs as white to light yellow, crystals or crystalline powder.

It is freely soluble in acetic acid (100), sparingly soluble in ethanol (95), very slightly soluble in diethyl ether, and practically insoluble in water.

It dissolves in dilute hydrochloric acid.

It is gradually affected by light.

Melting point: about 240°C (with decomposition).

Identification (1) Determine the absorption spectrum of a solution of Chlordiazepoxide in 0.1 mol/L hydrochloric acid TS (1 in 200,000) as directed under Ultraviolet-visible Spectrophotometry <2.24>, and compare the spectrum with the Reference Spectrum or the spectrum of a solution of Chlor-

diazepoxide RS prepared in the same manner as the sample solution: both spectra exhibit similar intensities of absorption at the same wavelengths.

(2) Determine the infrared absorption spectra of Chlordiazepoxide, previously dried, as directed in the potassium bromide disk method under Infrared Spectrophotometry <2.25>, and compare the spectrum with the Reference Spectrum or the spectrum of dried Chlordiazepoxide RS: both spectra exhibit similar intensities of absorption at the same wave numbers.

(3) Proceed with Chlordiazepoxide as directed under Flame Coloration Test <1.04> (2), and perform the test: a green color develops.

Purity (1) Heavy metals <1.07>—Proceed with 1.0 g of Chlordiazepoxide according to Method 2, and perform the test. Prepare the control solution with 2.0 mL of Standard Lead Solution (not more than 20 ppm).

(2) Related substances—Conduct this procedure without exposure to light, using light-resistant vessels. Dissolve 0.20 g of Chlordiazepoxide in exactly 10 mL of a mixture of methanol and ammonia TS (97:3), and use this solution as the sample solution. Pipet 1 mL of the sample solution, add a mixture of methanol and ammonia TS (97:3) to make exactly 200 mL, and use this solution as the standard solution (1). Separately, dissolve 10 mg of 2-amino-5-chlorobenzophenone for thin-layer chromatography in methanol to make exactly 200 mL, and use this solution as the standard solution (2). Perform the test with these solutions as directed under Thin-layer Chromatography <2.03>. Spot 25 μ L of the sample solution and 5 μ L each of the standard solutions (1) and (2) on a plate of silica gel with fluorescent indicator for thin-layer chromatography. Develop the plate with a mixture of ethyl acetate and ethanol (99.5) (19:1) to a distance of about 12 cm, and air-dry the plate. Examine under ultraviolet light (main wavelength: 254 nm): the spots other than the principal spot obtained from the sample solution are not more intense than the spot from the standard solution (1). Spray evenly a solution of sodium nitrite in 1 mol/L hydrochloric acid TS (1 in 100) on the plate, allow to stand for 1 minute, and spray evenly *N*-(1-naphthyl)-*N'*-diethylethylenediamine oxalate-acetone TS on the plate: the spots from the sample solution are not more intense than the spots from the standard solution (2).

Loss on drying <2.41> Not more than 0.5% (1 g, in vacuum, phosphorus (V) oxide, 60°C, 4 hours).

Residue on ignition <2.44> Not more than 0.1% (1 g).

Assay Weigh accurately about 0.6 g of Chlordiazepoxide, previously dried, and dissolve in 50 mL of acetic acid (100). Titrate <2.50> with 0.1 mol/L perchloric acid VS until the color of the supernatant liquid changes from purple through blue-purple to blue (indicator: 3 drops of crystal violet TS). Perform a blank determination in the same manner, and make any necessary correction.

Each mL of 0.1 mol/L perchloric acid VS
= 29.98 mg of $C_{16}H_{14}ClN_3O$

Containers and storage Containers—Tight containers.

Storage—Light-resistant.

Chlordiazepoxide Powder

クロルジアゼポキシド散

Chlordiazepoxide Powder contains not less than 93.0% and not more than 107.0% of the labeled amount of chlordiazepoxide ($C_{16}H_{14}ClN_3O$: 299.75).

Method of preparation Prepare as directed under Granules or Powders, with Chlordiazepoxide.

Identification (1) Weigh a portion of Chlordiazepoxide Powder, equivalent to 0.01 g of Chlordiazepoxide, add 100 mL of 0.1 mol/L hydrochloric acid TS, shake, and filter. To 5 mL of the filtrate add 0.1 mol/L hydrochloric acid TS to make 100 mL, and determine the absorption spectrum of this solution as directed under Ultraviolet-visible Spectrophotometry <2.24>: it exhibits maxima between 244 nm and 248 nm and between 306 nm and 310 nm, and a minimum between 288 nm and 292 nm.

(2) Weigh a portion of Chlordiazepoxide Powder, equivalent to 0.02 g of Chlordiazepoxide, add 10 mL of methanol, shake for 5 minutes, then filter by suction through a glass filter (G4), evaporate the filtrate with the aid of a current of air to dryness, and dry the residue in vacuum at 60°C for 1 hour. Determine the infrared absorption spectrum of the residue as directed in the potassium bromide disk method under Infrared Spectrophotometry <2.25>: it exhibits absorption at the wave numbers of about 1625 cm^{-1} , 1465 cm^{-1} , 1265 cm^{-1} , 850 cm^{-1} and 765 cm^{-1} .

Purity Conduct this procedure without exposure to light, using light-resistant vessels. To a portion of Chlordiazepoxide Powder, equivalent to 50 mg of Chlordiazepoxide, add exactly 5 mL of a mixture of methanol and ammonia TS (97:3), shake, centrifuge, and use the supernatant liquid as the sample solution. Separately, dissolve 50 mg of Chlordiazepoxide RS in a mixture of methanol and ammonia TS (97:3) to make exactly 50 mL, and use this solution as the standard solution (1). Dissolve 5.0 mg of 2-amino-5-chlorobenzophenone for thin-layer chromatography in methanol to make exactly 200 mL, and use this solution as the standard solution (2). Perform the test with these solutions as directed under Thin-layer Chromatography <2.03>. Spot 25 μL of the sample solution and 10 μL each of the standard solutions (1) and (2) on a plate of silica gel with fluorescent indicator for thin-layer chromatography. Proceed as directed in the Purity (2) under Chlordiazepoxide.

Dissolution <6.10> When the test is performed at 100 revolutions per minute according to the Paddle method, using 900 mL of 2nd fluid for dissolution test as the dissolution medium, the dissolution rate in 60 minutes of Chlordiazepoxide Powder is not less than 70%.

Start the test with an accurately weighed amount of Chlordiazepoxide Powder, equivalent to about 3.3 mg of chlordiazepoxide ($C_{16}H_{14}ClN_3O$), withdraw not less than 15 mL of the medium at the specified minute after starting the test, and filter through a membrane filter with a pore size not exceeding 0.45 μm . Discard not less than 10 mL of the first filtrate, and use the subsequent filtrate as the sample solution. Separately, weigh accurately about 12 mg of Chlordiazepoxide RS, previously dried in a desiccator (in vacuum, phosphorus (V) oxide, 60°C) for 4 hours, dissolve in 20 mL of 0.1 mol/L hydrochloric acid TS, and add the dissolution medium to make exactly 200 mL. Pipet 3 mL of this solution, add the dissolution medium to make exactly 50 mL,

and use this solution as the standard solution. Determine the absorbances, A_T and A_S , at 260 nm of the sample solution and standard solution as directed under Ultraviolet-visible Spectrophotometry <2.24>.

Dissolution rate (%) with respect to the labeled amount of chlordiazepoxide ($C_{16}H_{14}ClN_3O$)

$$= M_S/M_T \times A_T/A_S \times 1/C \times 27$$

M_S : Amount (mg) of Chlordiazepoxide RS taken

M_T : Amount (g) of Chlordiazepoxide Powder taken

C: Labeled amount (mg) of chlordiazepoxide ($C_{16}H_{14}ClN_3O$) in 1 g

Assay Conduct this procedure without exposure to light, using light-resistant vessels. Weigh accurately a quantity of Chlordiazepoxide Powder, equivalent to about 0.1 g of chlordiazepoxide ($C_{16}H_{14}ClN_3O$), transfer to a glass-stoppered flask, wet with exactly 10 mL of water, add exactly 90 mL of methanol, stopper, shake vigorously for 15 minutes, and centrifuge. Pipet 10 mL of the supernatant liquid, add exactly 5 mL of the internal standard solution, add methanol to make 100 mL, and use this solution as the sample solution. Separately, weigh accurately about 0.1 g of Chlordiazepoxide RS, previously dried in a desiccator (in vacuum, phosphorus (V) oxide, 60°C) for 4 hours, and dissolve in exactly 10 mL of water and exactly 90 mL of methanol. Pipet 10 mL of this solution, add exactly 5 mL of the internal standard solution, add methanol to make 100 mL, and use this solution as the standard solution. Perform the test with 10 μL each of the sample solution and standard solution as directed under Liquid Chromatography <2.01> according to the following conditions, and calculate the ratios, Q_T and Q_S , of the peak area of chlordiazepoxide to that of the internal standard.

Amount (mg) of chlordiazepoxide ($C_{16}H_{14}ClN_3O$)

$$= M_S \times Q_T/Q_S$$

M_S : Amount (mg) of Chlordiazepoxide RS taken

Internal standard solution—A solution of isobutyl salicylate in methanol (1 in 20).

Operating conditions—

Detector: An ultraviolet absorption photometer (wavelength: 254 nm).

Column: A stainless steel column 4 mm in inside diameter and 25 cm in length, packed with octadecylsilanized silica gel for liquid chromatography (10 μm in particle diameter).

Column temperature: A constant temperature of about 25°C.

Mobile phase: A mixture of methanol and 0.02 mol/L ammonium dihydrogenphosphate TS (7:3).

Flow rate: Adjust so that the retention time of chlordiazepoxide is about 5 minutes.

System suitability—

System performance: When the procedure is run with 10 μL of the standard solution under the above operating conditions, chlordiazepoxide and the internal standard are eluted in this order with the resolution between these peaks being not less than 9.

System repeatability: When the test is repeated 6 times with 10 μL of the standard solution under the above operating conditions, the relative standard deviation of the ratios of the peak area of chlordiazepoxide to that of the internal standard is not more than 1.0%.

Containers and storage Containers—Tight containers.

Storage—Light-resistant.

Chlordiazepoxide Tablets

クロルジアゼポキシド錠

Chlordiazepoxide Tablets contain not less than 93.0% and not more than 107.0% of the labeled amount of chlordiazepoxide ($C_{16}H_{14}ClN_3O$: 299.75).

Method of preparation Prepare as directed under Tablets, with Chlordiazepoxide.

Identification (1) Weigh a portion of powdered Chlordiazepoxide Tablets, equivalent to 0.01 g of Chlordiazepoxide, add 100 mL of 0.1 mol/L hydrochloric acid TS, shake, and filter. To 5 mL of the filtrate add 0.1 mol/L hydrochloric acid TS to make 100 mL, and determine the absorption spectrum of this solution as directed under Ultraviolet-visible Spectrophotometry <2.24>: it exhibits maxima between 244 nm and 248 nm and between 306 nm and 310 nm, and a minimum between 288 nm and 292 nm.

(2) Weigh a portion of powdered Chlordiazepoxide Tablets, equivalent to 0.01 g of Chlordiazepoxide, add 10 mL of diethyl ether, shake vigorously, and centrifuge. Evaporate 5 mL of the supernatant liquid by warming on a water bath to dryness. Determine the infrared absorption spectrum of the residue as directed in the potassium bromide disk method under Infrared Spectrophotometry <2.25>: it exhibits absorption at the wave numbers of about 1625 cm^{-1} , 1465 cm^{-1} , 1265 cm^{-1} , 850 cm^{-1} and 765 cm^{-1} .

Purity Related substances—Conduct this procedure without exposure to light, using light-resistant vessels. To a portion of powdered Chlordiazepoxide Tablets, equivalent to 50 mg of Chlordiazepoxide, add exactly 5 mL of a mixture of methanol and ammonia TS (97:3), shake, centrifuge, and use the supernatant liquid as the sample solution. Separately, dissolve 50 mg of Chlordiazepoxide RS in a mixture of methanol and ammonia TS (97:3) to make exactly 50 mL, and use this solution as the standard solution (1). Dissolve 5.0 mg of 2-amino-5-chlorobenzophenone for thin-layer chromatography in methanol to make exactly 200 mL, and use this solution as the standard solution (2). Perform the test with these solutions as directed under Thin-layer Chromatography <2.03>. Spot 25 μL of the sample solution and 10 μL each of the standard solutions (1) and (2) on a plate of silica gel with fluorescent indicator for thin-layer chromatography. Proceed as directed in the Purity (2) under Chlordiazepoxide.

Uniformity of dosage units <6.02> Perform the test according to the following method: it meets the requirement of the Content uniformity test.

Conduct this procedure without exposure to light, using light-resistant vessels. To 1 tablet of Chlordiazepoxide Tablets add 1 mL of water, shake to disintegrate the tablet, then add 20 mL of methanol, shake, add methanol to make exactly 25 mL, and filter through a membrane filter with a pore size not exceeding $0.5\text{ }\mu\text{m}$. Discard the first 5 mL of the filtrate, take exactly V mL of the subsequent filtrate equivalent to about 2 mg of chlordiazepoxide ($C_{16}H_{14}ClN_3O$), add exactly 1 mL of the internal standard solution, then add methanol to make 20 mL, and use this solution as the sample solution. Then, proceed as directed in the Assay.

$$\begin{aligned} &\text{Amount (mg) of chlordiazepoxide (C}_{16}\text{H}_{14}\text{ClN}_3\text{O)} \\ &= M_S \times Q_T/Q_S \times 5/V \end{aligned}$$

M_S : Amount (mg) of Chlordiazepoxide RS taken

Internal standard solution—A solution of isobutyl salicylate

in methanol (1 in 20).

Dissolution <6.10> When the test is performed at 100 revolutions per minute according to the Paddle method, using 900 mL of 2nd fluid for dissolution test as the dissolution medium, the dissolution rate in 60 minutes of Chlordiazepoxide Tablets is not less than 70%.

Conduct this procedure without exposure to light, using light-resistant vessels. Start the test with 1 tablet of Chlordiazepoxide Tablets, withdraw not less than 30 mL of the medium at the specified minute after starting the test, and filter through a membrane filter with a pore size not exceeding $0.8\text{ }\mu\text{m}$. Discard not less than 10 mL of the first filtrate, pipet V mL of the subsequent filtrate, add the dissolution medium to make exactly V' mL so that each mL contains about $3.7\text{ }\mu\text{g}$ of chlordiazepoxide ($C_{16}H_{14}ClN_3O$), and use this solution as the sample solution. Separately, weigh accurately about 12 mg of Chlordiazepoxide RS, previously dried under reduced pressure with phosphorus (V) oxide as a desiccant at 60°C for 4 hours, dissolve in 5 mL of 0.1 mol/L hydrochloric acid TS, and add the dissolution medium to make exactly 200 mL. Pipet 3 mL of this solution, add the dissolution medium to make exactly 50 mL, and use this solution as the standard solution. Determine the absorbances, A_T and A_S , at 260 nm of the sample solution and standard solution as directed under Ultraviolet-visible Spectrophotometry <2.24>.

$$\begin{aligned} &\text{Dissolution rate (\%)} \text{ with respect to the labeled amount} \\ &\text{of chlordiazepoxide (C}_{16}\text{H}_{14}\text{ClN}_3\text{O)} \\ &= M_S \times A_T/A_S \times V'/V \times 1/C \times 27 \end{aligned}$$

M_S : Amount (mg) of Chlordiazepoxide RS taken

C : Labeled amount (mg) of chlordiazepoxide ($C_{16}H_{14}ClN_3O$) in 1 tablet

Assay Conduct this procedure without exposure to light, using light-resistant vessels. Weigh accurately a quantity of Chlordiazepoxide Tablets, equivalent to about 0.1 g of chlordiazepoxide ($C_{16}H_{14}ClN_3O$), add 10 mL of water, and shake well to disintegrate. Add 60 mL of methanol, shake well, add methanol to make exactly 100 mL, and centrifuge. Pipet 10 mL of the supernatant liquid, add exactly 5 mL of the internal standard solution, add methanol to make exactly 100 mL, and use this solution as the sample solution. Separately, weigh accurately about 10 mg of Chlordiazepoxide RS, previously dried in a desiccator (in vacuum, phosphorus (V) oxide, 60°C) for 4 hours, dissolve in 1 mL of water and a suitable amount of methanol, add exactly 5 mL of the internal standard solution, add methanol to make 100 mL, and use this solution as the standard solution. Perform the test with 10 μL each of the sample solution and standard solution as directed under Liquid Chromatography <2.01> according to the following conditions, and calculate the ratios, Q_T and Q_S , of the peak area of chlordiazepoxide to that of the internal standard.

$$\begin{aligned} &\text{Amount (mg) of chlordiazepoxide (C}_{16}\text{H}_{14}\text{ClN}_3\text{O)} \\ &= M_S \times Q_T/Q_S \times 10 \end{aligned}$$

M_S : Amount (mg) of Chlordiazepoxide RS taken

Internal standard solution—A solution of isobutyl salicylate in methanol (1 in 20).

Operating conditions—

Detector: An ultraviolet absorption photometer (wavelength: 254 nm).

Column: A stainless steel column 4 mm in inside diameter and 25 cm in length, packed with octadecylsilanized silica gel for liquid chromatography ($10\text{ }\mu\text{m}$ in particle diameter).

Column temperature: A constant temperature of about 25°C.

Mobile phase: A mixture of methanol and 0.02 mol/L ammonium dihydrogenphosphate TS (7:3).

Flow rate: Adjust so that the retention time of chlordiazeponide is about 5 minutes.

System suitability—

System performance: When the procedure is run with 10 µL of the standard solution under the above operating conditions, chlordiazeponide and the internal standard are eluted in this order with the resolution between these peaks being not less than 9.

System repeatability: When the test is repeated 6 times with 10 µL of the standard solution under the above operating conditions, the relative standard deviation of the ratios of the peak area of chlordiazeponide to that of the internal standard is not more than 1.0%.

Containers and storage Containers—Tight containers.

Chlorhexidine Gluconate Solution

クロルヘキシジングルコン酸塩液

Chlorhexidine Gluconate Solution is a solution of digluconate of chlorhexidine.

It contains not less than 19.0 w/v% and not more than 21.0 w/v% of chlorhexidine gluconate (C₂₂H₃₀Cl₂N₁₀·2C₆H₁₂O₇; 897.76).

Description Chlorhexidine Gluconate Solution is a clear, colorless or pale yellow liquid. It is odorless, and has a bitter taste.

It is miscible with water and with acetic acid (100). 1 mL of Chlorhexidine Gluconate Solution is miscible with not more than 5 mL of ethanol (99.5) and with not more than 3 mL of acetone. By further addition of each of these solvents, a white turbidity is formed.

It is gradually colored by light.

Specific gravity d_{20}^{20} : 1.06 – 1.07

Identification (1) To 0.05 mL of Chlorhexidine Gluconate Solution add 5 mL of methanol, 1 mL of bromine TS and 1 mL of 8 mol/L sodium hydroxide TS: a deep red color is produced.

(2) To 0.5 mL of Chlorhexidine Gluconate Solution add 10 mL of water and 0.5 mL of copper (II) sulfate TS: a white precipitate is formed. Heat to boiling: the precipitate changes to light purple.

(3) To 10 mL of Chlorhexidine Gluconate Solution add 5 mL of water, cool on ice, and add 5 mL of sodium hydroxide TS dropwise with stirring: a white precipitate is formed. Collect the precipitate by filtration, wash with water, recrystallize from diluted ethanol (95) (7 in 10), and dry at 105°C for 30 minutes: the crystals thus obtained melt <2.60> between 130°C and 134°C.

(4) Neutralize the filtrate obtained in (3) with 5 mol/L hydrochloric acid TS. To 5 mL of this solution add 0.65 mL of acetic acid (100) and 1 mL of freshly distilled phenylhydrazine, and heat on a water bath for 30 minutes. After cooling, scratch the inner wall of the vessel with a glass rod to induce crystallization. Collect the crystals, dissolve in 10 mL of hot water, add a small amount of activated charcoal, and filter. Cool the filtrate, scratch the inner side of the vessel, collect the formed crystals, and dry: the crystals thus obtained melt <2.60> at about 195°C (with decomposition).

pH <2.54> To 5.0 mL of Chlorhexidine Gluconate Solution add water to make 100 mL: the pH of the solution is between 5.5 and 7.0.

Purity 4-Chloroaniline—To 2.0 mL of Chlorhexidine Gluconate Solution add water to make exactly 100 mL. Pipet 5 mL of the solution, and add 20 mL of water and 5 mL of 1 mol/L hydrochloric acid TS. Add 0.3 mL of sodium nitrite TS, shake, and allow to stand for 2 minutes. Add 4 mL of ammonium amidosulfate TS, and then allow to stand for 1 minute. Add 5 mL of *N*-(1-naphthyl)-*N'*-diethylethylenediamine oxalate-acetone TS, allow to stand for 10 minutes, add 1 mL of ethanol (95), and then add water to make 50 mL: the color of the solution is not more intense than the following control solution.

Control solution: Dissolve 20 mg of 4-chloroaniline in 10 mL of 1 mol/L hydrochloric acid TS, and add water to make exactly 100 mL. Pipet 5 mL of the solution, and add water to make exactly 100 mL. Pipet 5 mL of the solution, add 20 mL of water and 5 mL of 1 mol/L hydrochloric acid TS, and proceed as directed for the preparation of the sample solution.

Residue on ignition <2.44> Not more than 0.1% (2 g, after evaporation).

Assay Pipet 2 mL of Chlorhexidine Gluconate Solution, evaporate to dryness on a water bath, dissolve the residue in 60 mL of acetic acid for nonaqueous titration, and titrate <2.50> with 0.1 mol/L perchloric acid VS (potentiometric titration). Perform a blank determination in the same manner, and make any necessary correction.

Each mL of 0.1 mol/L perchloric acid VS
= 22.44 mg of C₂₂H₃₀Cl₂N₁₀·2C₆H₁₂O₇

Containers and storage Containers—Tight containers.
Storage—Light-resistant.

Chlorhexidine Hydrochloride

クロルヘキシジン塩酸塩

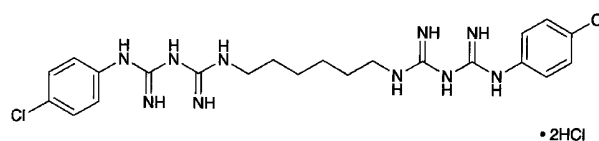

C₂₂H₃₀Cl₂N₁₀·2HCl: 578.37

1,1'-Hexamethylenebis[5-(4-chlorophenyl)biguanide] dihydrochloride
[3697-42-5]

Chlorhexidine Hydrochloride, when dried, contains not less than 98.0% of chlorhexidine hydrochloride (C₂₂H₃₀Cl₂N₁₀·2HCl).

Description Chlorhexidine Hydrochloride occurs as a white crystalline powder. It is odorless, and has a bitter taste.

It is soluble in formic acid, slightly soluble in methanol and in warm methanol, and practically insoluble in water, in ethanol (95) and in diethyl ether.

It is gradually colored by light.

Identification (1) Dissolve 0.01 g of Chlorhexidine Hydrochloride in 5 mL of methanol by warming, and add 1 mL of bromine TS and 1 mL of 8 mol/L sodium hydroxide TS: a deep red color is produced.

(2) Dissolve 0.3 g of Chlorhexidine Hydrochloride in 10

mL of 6 mol/L hydrochloric acid TS, cool in ice, and add 10 mL of 8 mol/L sodium hydroxide TS dropwise with stirring: a white precipitate is produced. Collect the precipitate, wash with water, recrystallize from diluted ethanol (95) (7 in 10), and dry at 105°C for 30 minutes: the crystals so obtained melt <2.60> between 130°C and 134°C.

(3) Dissolve 0.1 g of Chlorhexidine Hydrochloride in 50 mL of dilute nitric acid: the solution responds to Qualitative Tests <1.09> for chloride.

Purity (1) Heavy metals <1.07>—Proceed with 2.0 g of Chlorhexidine Hydrochloride according to Method 2, and perform the test. Prepare the control solution with 2.0 mL of Standard Lead Solution (not more than 10 ppm).

(2) Arsenic <1.11>—To 1.0 g of Chlorhexidine Hydrochloride in a crucible add 10 mL of a solution of magnesium nitrate hexahydrate in ethanol (95) (1 in 10), fire the ethanol (95) to burn, and heat gradually to incinerate. If a carbonized substance remains, moisten with a small amount of nitric acid, and ignite to incinerate. Cool, add 10 mL of dilute hydrochloric acid to the residue, dissolve by warming on a water bath, use this solution as the test solution, and perform the test (not more than 2 ppm).

(3) *p*-Chloroaniline—Dissolve 0.10 g of Chlorhexidine Hydrochloride in 2 mL of formic acid, and add 15 mL of 1 mol/L hydrochloric acid TS and 20 mL of water immediately. Add 0.3 mL of sodium nitrite TS, shake, and allow to stand for 2 minutes. Add 4 mL of ammonium amidosulfate TS, and then allow to stand for 1 minute. Add 5 mL of *N*-(1-naphthyl)-*N'*-diethylethylenediamine oxalate-acetone TS, allow to stand for 10 minutes, and add 1 mL of ethanol (95) and water to make 50 mL: the solution has no more color than the following control solution.

Control solution: Dissolve 20 mg of 4-chloroaniline in 10 mL of 1 mol/L hydrochloric acid TS, and add water to make exactly 100 mL. Pipet 5 mL of the solution, and add water to make exactly 100 mL. To 2.0 mL of the solution add 2 mL of formic acid, 15 mL of 1 mol/L hydrochloric acid TS and 20 mL of water, and proceed in the same manner.

Loss on drying <2.41> Not more than 2.0% (1 g, 130°C, 2 hours).

Residue on ignition <2.44> Not more than 0.1% (1 g).

Assay Weigh accurately about 0.2 g of Chlorhexidine Hydrochloride, previously dried, dissolve in 2.0 mL of formic acid, add 60 mL of acetic anhydride, and titrate <2.50> with 0.1 mol/L perchloric acid VS (potentiometric titration). Perform a blank determination in the same manner, and make any necessary correction.

Each mL of 0.1 mol/L perchloric acid VS
= 14.46 mg of C₂₂H₃₀Cl₂N₁₀·2HCl

Containers and storage Containers—Tight containers.
Storage—Light-resistant.

Chlorinated Lime

サラシ粉

Chlorinated Lime contains not less than 30.0% of available chlorine (Cl: 35.45).

Description Chlorinated Lime occurs as a white powder. It has a chlorine-like odor.

It dissolves partially in water. The solution changes red litmus paper to blue, then gradually decolorizes.

Identification (1) To Chlorinated Lime add dilute hydrochloric acid: a gas, which has the odor of chlorine, evolves, and the gas changes moistened starch-potassium iodide paper to blue.

(2) Shake 1 g of Chlorinated Lime with 10 mL of water, and filter: the filtrate responds to Qualitative Tests <1.09> (2) and (3) for calcium salt.

Assay Weigh accurately about 5 g of Chlorinated Lime, transfer to a mortar, and triturate thoroughly with 50 mL of water. Transfer to a 500-mL volumetric flask with the aid of water, and add water to make 500 mL. Mix well, immediately take exactly 50 mL of the mixture in an iodine flask, add 10 mL of potassium iodide TS and 10 mL of dilute hydrochloric acid, and titrate <2.50> the liberated iodine with 0.1 mol/L sodium thiosulfate VS (indicator: 3 mL of starch TS). Perform a blank determination in the same manner, and make any necessary correction.

Each mL of 0.1 mol/L sodium thiosulfate VS
= 3.545 mg of Cl

Containers and storage Containers—Tight containers.
Storage—Light-resistant, and in a cold place.

Chlormadinone Acetate

クロルマジノン酢酸エステル

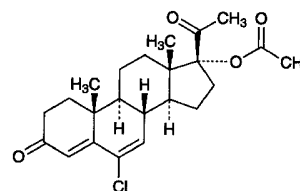

C₂₃H₂₉ClO₄: 404.93
6-Chloro-3,20-dioxopregna-4,6-dien-17-yl acetate
[302-22-7]

Chlormadinone Acetate, when dried, contains not less than 98.0% of chlormadinone acetate (C₂₃H₂₉ClO₄).

Description Chlormadinone Acetate occurs as white to light yellow, crystals or crystalline powder. It is odorless.

It is freely soluble in chloroform, soluble in acetonitrile, slightly soluble in ethanol (95) and in diethyl ether, and practically insoluble in water.

Identification (1) Dissolve 2 mg of Chlormadinone Acetate in 1 mL of ethanol (95), and add 1 mL of 1,3-dinitrobenzene TS and 1 mL of a solution of potassium hydroxide (1 in 5): a red-purple color develops.

(2) To 0.05 g of Chlormadinone Acetate add 2 mL of potassium hydroxide-ethanol TS, and boil on a water bath for 5 minutes. After cooling, add 2 mL of diluted sulfuric acid (2 in 7), and boil gently for 1 minute: the odor of ethyl acetate is perceptible.

(3) Determine the infrared absorption spectrum of Chlormadinone Acetate, previously dried, as directed in the potassium bromide disk method under Infrared Spectrophotometry <2.25>, and compare the spectrum with the Reference Spectrum or the spectrum of previously dried Chlormadinone Acetate RS: both spectra exhibit similar intensities of absorption at the same wave numbers.

(4) Perform the test with Chlormadinone Acetate as directed under Flame Coloration Test <1.04> (2): a green color

appears.

Optical rotation <2.49> $[\alpha]_D^{20}$: -10.0 – -14.0° (after drying, 0.2 g, acetonitrile, 10 mL, 100 mm).

Melting point <2.60> 211 – 215°C

Purity (1) Heavy metals <1.07>—Proceed with 1.0 g of Chlormadinone Acetate according to Method 2, and perform the test. Prepare the control solution with 2.0 mL of Standard Lead Solution (not more than 20 ppm).

(2) Arsenic <1.11>—Prepare the test solution with 1.0 g of Chlormadinone Acetate according to Method 3, and perform the test (not more than 2 ppm).

(3) Related substances—Dissolve 20 mg of Chlormadinone Acetate in 10 mL of acetonitrile, and use this solution as the sample solution. Pipet 1 mL of the sample solution, add acetonitrile to make exactly 100 mL, and use this solution as the standard solution. Perform the test with exactly 10 μL each of the sample solution and standard solution as directed under Liquid Chromatography <2.01> according to the following conditions, and determine each peak area by the automatic integration method: the total area of peaks other than the peak of chlormadinone acetate obtained from the sample solution is not larger than the peak area of chlormadinone acetate from the standard solution.

Operating conditions—

Detector: An ultraviolet absorption photometer (wavelength: 236 nm).

Column: A stainless steel column 6 mm in inside diameter and 15 cm in length, packed with octadecylsilanized silica gel for liquid chromatography (5 μm in particle diameter).

Column temperature: A constant temperature of about 30°C .

Mobile phase: A mixture of acetonitrile and water (13:7).

Flow rate: Adjust so that the retention time of chlormadinone acetate is about 10 minutes.

Time span of measurement: About 1.5 times as long as the retention time of chlormadinone acetate, beginning after the solvent peak.

System suitability—

Test for required detectability: To exactly 5 mL of the standard solution add acetonitrile to make exactly 50 mL. Confirm that the peak area of chlormadinone acetate obtained with 10 μL of this solution is equivalent to 7 to 13% of that with 10 μL of the standard solution.

System performance: Dissolve 8 mg of Chlormadinone Acetate and 2 mg of butyl parahydroxybenzoate in 100 mL of acetonitrile. When the procedure is run with 10 μL of this solution under the above operating conditions, butyl parahydroxybenzoate and chlormadinone acetate are eluted in this order with the resolution between these peaks being not less than 8.

System repeatability: When the test is repeated 6 times with 10 μL of the standard solution under the above operating conditions, the relative standard deviation of the peak area of chlormadinone acetate is not more than 1.0%.

Loss on drying <2.41> Not more than 0.5% (0.5 g, in vacuum, phosphorus (V) oxide, 4 hours).

Residue on ignition <2.44> Not more than 0.1% (0.5 g).

Assay Weigh accurately about 20 mg each of Chlormadinone Acetate and Chlormadinone Acetate RS, previously dried, and dissolve in ethanol (95) to make exactly 100 mL. Pipet 5 mL each of these solutions, to each add ethanol (95) to make exactly 100 mL, and use these solutions as the sample solution and the standard solution, respectively. Perform the test with these solutions as directed under Ultraviolet-

visible Spectrophotometry <2.24>, and determine the absorbances, A_T and A_S , at 285 nm.

$$\text{Amount (mg) of chlormadinone acetate (C}_{23}\text{H}_{29}\text{ClO}_4) = M_S \times A_T/A_S$$

M_S : Amount (mg) of Chlormadinone Acetate RS taken

Containers and storage Containers—Tight containers. Storage—Light-resistant.

Chlorobutanol

クロロブタノール

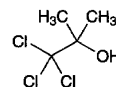

$\text{C}_4\text{H}_7\text{Cl}_3\text{O}$: 177.46

1,1,1-Trichloro-2-methylpropan-2-ol
[57-15-8]

Chlorobutanol contains not less than 98.0% of chlorobutanol ($\text{C}_4\text{H}_7\text{Cl}_3\text{O}$), calculated on the anhydrous basis.

Description Chlorobutanol occurs as colorless or white crystals. It has a camphoraceous odor.

It is very soluble in methanol, in ethanol (95) and in diethyl ether, and slightly soluble in water.

It slowly volatilizes in air.

Melting point: not lower than about 76°C .

Identification (1) To 5 mL of a solution of Chlorobutanol (1 in 200) add 1 mL of sodium hydroxide TS, then slowly add 3 mL of iodine TS: a yellow precipitate is produced and the odor of iodoform is perceptible.

(2) To 0.1 g of Chlorobutanol add 5 mL of sodium hydroxide TS, shake well the mixture, add 3 to 4 drops of aniline, and warm gently: the disagreeable odor of phenyl isocyanide (poisonous) is perceptible.

Purity (1) Acidity—Shake thoroughly 0.10 g of the powder of Chlorobutanol with 5 mL of water: the solution is neutral.

(2) Chloride <1.03>—Dissolve 0.5 g of Chlorobutanol in 25 mL of dilute ethanol, and add 6 mL of dilute nitric acid and water to make 50 mL. Perform the test using this solution as the test solution. Prepare the control solution with 1.0 mL of 0.01 mol/L hydrochloric acid VS by adding 25 mL of dilute ethanol, 6 mL of dilute nitric acid and water to make 50 mL (not more than 0.071%).

Water <2.48> Not more than 6.0% (0.2 g, volumetric titration, direct titration).

Residue on ignition <2.44> Not more than 0.1% (1 g).

Assay Transfer about 0.1 g of Chlorobutanol, accurately weighed, to a 200-mL conical flask, and dissolve in 10 mL of ethanol (95). Add 10 mL of sodium hydroxide TS, boil under a reflux condenser for 10 minutes, cool, add 40 mL of dilute nitric acid and exactly 25 mL of 0.1 mol/L silver nitrate VS, and shake well. Add 3 mL of nitrobenzene, and shake vigorously until the precipitate is coagulated. Titrate <2.50> the excess silver nitrate with 0.1 mol/L ammonium thiocyanate VS (indicator: 2 mL of ammonium iron (III) sulfate TS). Perform a blank determination in the same manner.

Each mL of 0.1 mol/L silver nitrate VS
= 5.915 mg of C₁₀H₁₂ClNO₄

Containers and storage Containers—Tight containers.

Chlorphenesin Carbamate

クロルフェネシンカルバミン酸エステル

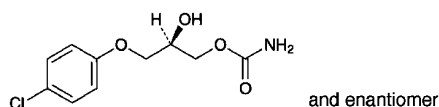

C₁₀H₁₂ClNO₄; 245.66
(2*RS*)-3-(4-Chlorophenoxy)-2-hydroxypropyl carbamate
[886-74-8]

Chlorphenesin Carbamate, when dried, contains not less than 98.0% and not more than 102.0% of chlorphenesin carbamate (C₁₀H₁₂ClNO₄).

Description Chlorphenesin Carbamate occurs as white, crystals or a crystalline powder.

It is freely soluble in methanol, in ethanol (95) and in pyridine, and slightly soluble in water.

A solution of Chlorphenesin Carbamate in ethanol (95) (1 in 20) shows no optical rotation.

Identification (1) Determine the absorption spectrum of a solution of Chlorphenesin Carbamate in ethanol (95) (3 in 200,000) as directed under Ultraviolet-visible Spectrophotometry <2.24>, and compare the spectrum with the Reference Spectrum: both spectra exhibit similar intensities of absorption at the same wavelengths.

(2) Determine the infrared absorption spectrum of Chlorphenesin Carbamate, as directed in the potassium bromide disk method under Infrared Spectrophotometry <2.25>, and compare the spectrum with the Reference Spectrum: both spectra exhibit similar intensities of absorption at the same wave numbers.

(3) Perform the test with Chlorphenesin Carbamate as directed under Flame Coloration Test <1.04> (2): a green color appears.

Melting point <2.60> 88 – 91°C

Purity (1) Heavy metals <1.07>—Dissolve 2.0 g of Chlorphenesin Carbamate in 20 mL of ethanol (95), and add 2 mL of dilute acetic acid and water to make 50 mL. Perform the test using this solution as the test solution. Prepare the control solution as follows: to 2.0 mL of Standard Lead Solution add 20 mL of ethanol (95), 2 mL of dilute acetic acid and water to make 50 mL (not more than 10 ppm).

(2) Arsenic <1.11>—Prepare the test solution with 1.0 g of Chlorphenesin Carbamate according to Method 3, and perform the test (not more than 2 ppm).

(3) Chlorphenesin-2-carbamate—Dissolve 0.10 g of Chlorphenesin Carbamate in 20 mL of a mixture of hexane for liquid chromatography and 2-propanol (7:3), and use this solution as the sample solution. Perform the test with 10 μL of the sample solution as directed under Liquid Chromatography <2.01> according to the following conditions. Determine the peak area, A_a, of chlorphenesin carbamate and the peak area, A_b, of chlorphenesin-2-carbamate by the automatic integration method: the ratio, A_b/(A_a + A_b), is not more than 0.007.

Operating conditions—

Detector: An ultraviolet absorption photometer (wave-

length: 280 nm).

Column: A stainless steel column 4 mm in inside diameter and 30 cm in length, packed with silica gel for liquid chromatography (5 μm in particle diameter).

Column temperature: A constant temperature of about 40°C.

Mobile phase: A mixture of hexane for liquid chromatography, 2-propanol and acetic acid (100) (700:300:1).

Flow rate: Adjust so that the retention time of chlorphenesin carbamate is about 9 minutes.

System suitability—

Test for required detectability: To 1 mL of the sample solution, add a mixture of hexane for liquid chromatography and 2-propanol (7:3) to make 100 mL, and use this solution as the solution for system suitability test. To exactly 5 mL of the solution for system suitability test add the mixture of hexane for liquid chromatography and 2-propanol (7:3) to make exactly 10 mL. Confirm that the peak area of chlorphenesin carbamate obtained with 10 μL of this solution is equivalent to 40 to 60% of that with 10 μL of the solution for system suitability test.

System performance: Dissolve 0.1 g of Chlorphenesin Carbamate in 50 mL of methanol. To 25 mL of this solution add 25 mL of dilute sodium hydroxide TS, and warm at 60°C for 20 minutes. To 20 mL of this solution add 5 mL of 1 mol/L hydrochloric acid TS, shake well with 20 mL of ethyl acetate, and allow to stand to separate the upper layer. When the procedure is run with 10 μL of this layer under the above operating conditions, chlorphenesin, chlorphenesin carbamate and chlorphenesin-2-carbamate are eluted in this order, with the relative retention times of chlorphenesin and chlorphenesin-2-carbamate to chlorphenesin carbamate being about 0.7 and about 1.2, respectively, and with the resolution between the peaks of chlorphenesin and chlorphenesin carbamate being not less than 2.0.

System repeatability: When the test is repeated 6 times with 10 μL of the solution for system suitability test under the above operating conditions, the relative standard deviation of the peak areas of chlorphenesin carbamate is not more than 2.0%.

(4) Related substances—Dissolve 0.10 g of Chlorphenesin Carbamate in 10 mL of ethanol (95), and use this solution as the sample solution. Pipet 1 mL of the sample solution, add ethanol (95) to make exactly 20 mL. Pipet 2 mL of this solution, add ethanol (95) to make exactly 20 mL, and use this solution as the standard solution. Perform the test with these solutions as directed under Thin-layer Chromatography <2.03>. Spot 50 μL each of the sample solution and standard solution on a plate of silica gel for thin-layer chromatography. Develop the plate with a mixture of ethyl acetate, methanol and ammonia solution (28) (17:2:1) to a distance of about 10 cm, and air-dry the plate. Allow the plate to stand in iodine vapor for 20 minutes: the spot other than the principal spot obtained from the sample solution is not more than one, and it is not more intense than the spot from the standard solution.

Loss on drying <2.41> Not more than 0.20% (1 g, in vacuum, silica gel, 4 hours).

Residue on ignition <2.44> Not more than 0.1% (1 g).

Assay Weigh accurately about 0.5 g of Chlorphenesin Carbamate, previously dried, dissolve in 20 mL of pyridine, add exactly 50 mL of 0.1 mol/L potassium hydroxide-ethanol TS, and warm at 70°C for 40 minutes. After cooling, add 100 mL of ethanol (95), and titrate <2.50> the excess potassium hydroxide with 0.1 mol/L hydrochloric acid VS until

the color of the solution changes from blue through blue-green to yellow (indicator: 1 mL of thymol blue TS). Perform a blank determination in the same manner.

Each mL of 0.1 mol/L potassium hydroxide-ethanol TS
= 24.57 mg of $C_{10}H_{12}ClNO_4$

Containers and storage Containers—Tight containers.

Chlorphenesin Carbamate Tablets

クロルフェネシンカルバミン酸エステル錠

Chlorphenesin Carbamate Tablets contain not less than 93.0% and not more than 107.0% of the labeled amount of chlorphenesin carbamate ($C_{10}H_{12}ClNO_4$; 245.66).

Method of preparation Prepare as directed under Tablets, with Chlorphenesin Carbamate.

Identification To a quantity of powdered Chlorphenesin Carbamate Tablets, equivalent to 0.15 g of Chlorphenesin Carbamate, add 60 mL of ethanol (95), sonicate, and add ethanol (95) to make 100 mL. Centrifuge 20 mL of this solution, add ethanol (95) to 1 mL of the supernatant liquid to make 100 mL, and determine the absorption spectrum of this solution as directed under Ultraviolet-visible Spectrophotometry <2.24>: it exhibits maxima between 226 nm and 230 nm, between 279 nm and 283 nm, and between 286 nm and 290 nm.

Uniformity of dosage units <6.02> Perform the Mass variation test, or the Content uniformity test according to the following method: it meets the requirement.

To 1 tablet of Chlorphenesin Carbamate Tablets add 10 mL of water to disintegrate the tablet, add 70 mL of a mixture of water and methanol (1:1), sonicate for 15 minutes with occasional stirring, then add the mixture of water and methanol (1:1) to make exactly 100 mL. Centrifuge this solution, pipet V mL of the supernatant liquid equivalent to about 2.5 mg of chlorphenesin carbamate ($C_{10}H_{12}ClNO_4$), add the mixture of water and methanol (1:1) to make exactly 25 mL, and use this solution as the sample solution. Separately, weigh accurately about 50 mg of chlorphenesin carbamate for assay, previously dried in a desiccator (in vacuum, silica gel) for 4 hours, and dissolve in the mixture of water and methanol (1:1) to make exactly 50 mL. Pipet 2 mL of this solution, add the mixture of water and methanol (1:1) to make exactly 20 mL, and use this solution as the standard solution. Determine the absorbances at 280 nm, A_T and A_S , of the sample solution and standard solution as directed under Ultraviolet-visible Spectrophotometry <2.24>.

$$\begin{aligned} & \text{Amount (mg) of chlorphenesin carbamate} \\ & (C_{10}H_{12}ClNO_4) \\ & = M_S \times A_T/A_S \times 1/V \times 5 \end{aligned}$$

M_S : Amount (mg) of chlorphenesin carbamate for assay taken

Dissolution <6.10> When the test is performed at 50 revolutions per minute according to the Paddle method, using 900 mL of water as the dissolution medium, the dissolution rate in 15 minutes of Chlorphenesin Carbamate Tablets is not less than 85%.

Start the test with 1 tablet of Chlorphenesin Carbamate Tablets, withdraw not less than 20 mL of the medium at the specified minute after starting the test, and filter through a

membrane filter with a pore size not exceeding 0.45 μ m. Discard not less than 10 mL of the first filtrate, pipet V mL of the subsequent filtrate, add water to make exactly V' mL so that each mL contains about 0.14 mg of chlorphenesin carbamate ($C_{10}H_{12}ClNO_4$), and use this solution as the sample solution. Separately, weigh accurately about 28 mg of chlorphenesin carbamate for assay, previously dried in a desiccator (in vacuum, silica gel) for 4 hours, dissolve in 1 mL of methanol, and add water to make exactly 50 mL. Pipet 5 mL of this solution, add water to make exactly 20 mL, and use this solution as the standard solution. Determine the absorbances, A_T and A_S , at 278 nm of the sample solution and standard solution as directed under Ultraviolet-visible Spectrophotometry <2.24>.

Dissolution rate (%) with respect to the labeled amount of chlorphenesin carbamate ($C_{10}H_{12}ClNO_4$)

$$= M_S \times A_T/A_S \times V'/V \times 1/C \times 450$$

M_S : Amount (mg) of chlorphenesin carbamate for assay taken

C : Labeled amount (mg) of chlorphenesin carbamate ($C_{10}H_{12}ClNO_4$) in 1 tablet

Assay Weigh accurately the mass of not less than 20 Chlorphenesin Carbamate Tablets, and powder them in an agate mortar. Weigh accurately a portion of the powder, equivalent to about 0.25 g of chlorphenesin carbamate ($C_{10}H_{12}ClNO_4$), add 30 mL of ethyl acetate, disperse by sonicating, then add ethyl acetate to make exactly 50 mL. Centrifuge 20 mL of this solution, pipet 2 mL of the supernatant liquid, add exactly 2 mL of the internal standard solution, add ethyl acetate to make 20 mL, and use this solution as the sample solution. Separately, weigh accurately about 0.1 g of chlorphenesin carbamate for assay, previously dried in a desiccator (in vacuum, silica gel) for 4 hours, and dissolve in ethyl acetate to make exactly 50 mL. Pipet 5 mL of this solution, add exactly 2 mL of the internal standard solution, then add ethyl acetate to make 20 mL, and use this solution as the standard solution. Perform the test with 10 μ L each of the sample solution and standard solution as directed under Liquid Chromatography <2.01> according to the following conditions, and calculate the ratios, Q_T and Q_S , of the peak area of chlorphenesin carbamate to that of the internal standard.

$$\begin{aligned} & \text{Amount (mg) of chlorphenesin carbamate } (C_{10}H_{12}ClNO_4) \\ & = M_S \times Q_T/Q_S \times 5/2 \end{aligned}$$

M_S : Amount (mg) of chlorphenesin carbamate for assay taken

Internal standard solution—A solution of ethenzamide in ethyl acetate (1 in 400).

Operating conditions—

Detector: An ultraviolet absorption photometer (wavelength: 280 nm).

Column: A stainless steel column 4 mm in inside diameter and 30 cm in length, packed with silica gel for liquid chromatography (5 μ m in particle diameter).

Column temperature: A constant temperature of about 40°C.

Mobile phase: A mixture of hexane for liquid chromatography, 2-propanol and acetic acid (100) (700:300:1).

Flow rate: Adjust so that the retention time of chlorphenesin carbamate is about 9 minutes.

System suitability—

System performance: Proceed as directed in the system suitability in the Purity (3) under Chlorphenesin Carbamate.

System repeatability: When the test is repeated 6 times

with 10 μL of the standard solution under the above operating conditions, the relative standard deviation of the ratio of the peak area of chlorphenesin carbamate to that of the internal standard is not more than 1.5%.

Containers and storage Containers—Well-closed containers.

Chlorpheniramine Maleate

クロルフェニラミンマレイン酸塩

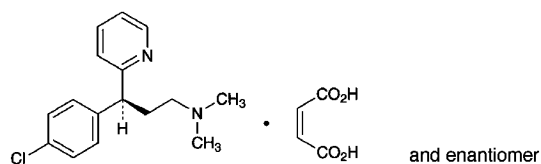

$\text{C}_{16}\text{H}_{19}\text{ClN}_2 \cdot \text{C}_4\text{H}_4\text{O}_4$: 390.86
(3*R*S)-3-(4-Chlorophenyl)-*N,N*-dimethyl-3-pyridin-2-ylpropylamine monomaleate
[113-92-8]

Chlorpheniramine Maleate, when dried, contains not less than 98.0% and not more than 101.0% of *dl*-chlorpheniramine maleate ($\text{C}_{16}\text{H}_{19}\text{ClN}_2 \cdot \text{C}_4\text{H}_4\text{O}_4$).

Description Chlorpheniramine Maleate occurs as white, fine crystals.

It is very soluble in acetic acid (100), freely soluble in water and in methanol, and soluble in ethanol (99.5).

It dissolves in dilute hydrochloric acid.

A solution of Chlorpheniramine Maleate (1 in 20) shows no optical rotation.

Identification (1) Determine the absorption spectrum of a solution of Chlorpheniramine Maleate in 0.1 mol/L hydrochloric acid TS (3 in 100,000) as directed under Ultraviolet-visible Spectrophotometry <2.24>, and compare the spectrum with the Reference Spectrum or the spectrum of a solution of Chlorpheniramine Maleate RS prepared in the same manner as the sample solution: both spectra exhibit similar intensities of absorption at the same wavelengths.

(2) Determine the infrared absorption spectrum of Chlorpheniramine Maleate, previously dried, as directed in the paste method under Infrared Spectrophotometry <2.25>, and compare the spectrum with the Reference Spectrum or the spectrum of previously dried Chlorpheniramine Maleate RS: both spectra exhibit similar intensities of absorption at the same wave numbers.

(3) Dissolve 0.10 g of Chlorpheniramine Maleate in 5 mL of methanol, and use this solution as the sample solution. Separately, dissolve 56 mg of maleic acid in 10 mL of methanol, and use this solution as the standard solution. Perform the test with these solutions as directed under Thin-layer Chromatography <2.03>. Spot 5 μL each of the sample solution and standard solution on a plate of silica gel for thin-layer chromatography. Develop the plate with a mixture of diethyl ether, methanol, acetic acid (100) and water (70:20:7:3) to a distance of about 12 cm, and air-dry the plate. Examine under ultraviolet light (main wavelength: 254 nm): a spot among two of the spots obtained with the sample solution shows the same intense and *R_f* value with the spot obtained with the standard solution.

pH <2.54> Dissolve 1.0 g of Chlorpheniramine Maleate in 100 mL of freshly boiled and cooled water: the pH of this solution is between 4.0 and 5.5.

Melting point <2.60> 130 – 135°C

Purity (1) Clarity and color of solution—Dissolve 1.0 g of Chlorpheniramine Maleate in 50 mL of water: the solution is clear and colorless.

(2) Heavy metals <1.07>—Proceed with 1.0 g of Chlorpheniramine Maleate according to Method 4, and perform the test. Prepare the control solution with 2.0 mL of Standard Lead Solution (not more than 20 ppm).

(3) Related substances—Dissolve 0.10 g of Chlorpheniramine Maleate in 100 mL of the mobile phase, and use this solution as the sample solution. Pipet 3 mL of the sample solution, and add the mobile phase to make exactly 100 mL. Pipet 2 mL of this solution, add the mobile phase to make exactly 20 mL, and use this solution as the standard solution. Perform the test with exactly 20 μL each of the sample solution and standard solution as directed under Liquid Chromatography <2.01> according to the following conditions, and determine each peak area by the automatic integration method: the area of the peak other than maleic acid and chlorpheniramine obtained from the sample solution is not larger than 2/3 times the peak area of chlorpheniramine from the standard solution, and the total area of the peaks other than maleic acid and chlorpheniramine from the sample solution is not larger than the peak area of chlorpheniramine from the standard solution.

Operating conditions—

Detector: An ultraviolet absorption photometer (wavelength: 225 nm).

Column: A stainless steel column 3.9 mm in inside diameter and 30 cm in length, packed with octadecylsilylated silica gel for liquid chromatography (10 μm in particle diameter).

Column temperature: A constant temperature of about 25°C.

Mobile phase: Dissolve 8.57 g of ammonium dihydrogenphosphate and 1 mL of phosphoric acid in water to make 1000 mL. To 800 mL of this solution add 200 mL of acetonitrile.

Flow rate: Adjust so that the retention time of chlorpheniramine is about 11 minutes.

Time span of measurement: About 4 times as long as the retention time of chlorpheniramine, beginning after the solvent peak.

System suitability—

Test for required detectability: To exactly 2.5 mL of the standard solution add the mobile phase to make exactly 25 mL. Confirm that the peak area of chlorpheniramine obtained with 20 μL of this solution is equivalent to 7 to 13% of that with 20 μL of the standard solution.

System performance: When the procedure is run with 20 μL of the standard solution under the above operating conditions, the number of theoretical plates and the symmetry factor of the peak of chlorpheniramine are not less than 4000 and not more than 2.0, respectively.

System repeatability: When the test is repeated 6 times with 20 μL of the standard solution under the above operating conditions, the relative standard deviation of the peak area of chlorpheniramine is not more than 4.0%.

Loss on drying <2.41> Not more than 0.5% (1 g, 105°C, 3 hours).

Residue on ignition <2.44> Not more than 0.1% (1 g).

Assay Dissolve about 0.4 g of Chlorpheniramine Maleate, previously dried and accurately weighed, in 20 mL of acetic acid (100). Titrate <2.50> with 0.1 mol/L perchloric acid VS until the color of the solution changes from purple through blue-green to green (indicator: 2 drops of crystal violet TS).

Perform a blank determination in the same manner, and make any necessary correction.

Each mL of 0.1 mol/L perchloric acid VS
= 19.54 mg of $C_{16}H_{19}ClN_2 \cdot C_4H_4O_4$

Containers and storage Containers—Tight containers.
Storage—Light-resistant.

Chlorpheniramine Maleate Injection

クロルフェニラミンマレイン酸塩注射液

Chlorpheniramine Maleate Injection is an aqueous injection.

It contains not less than 95.0% and not more than 105.0% of the labeled amount of *dl*-chlorpheniramine maleate ($C_{16}H_{19}ClN_2 \cdot C_4H_4O_4$: 390.86).

Method of preparation Prepare as directed under Injections, with Chlorpheniramine Maleate.

Description Chlorpheniramine Maleate Injection is a clear, colorless liquid.

pH: 4.5 – 7.0

Identification Take a volume of Chlorpheniramine Maleate Injection, equivalent to 25 mg of Chlorpheniramine Maleate, add 5 mL of dilute sodium hydroxide TS, and extract with 20 mL of hexane. Wash the hexane layer with 10 mL of water, shake with 0.5 g of anhydrous sodium sulfate for several minutes, and filter. Evaporate the filtrate in a water bath at 50°C under a reduced pressure, and determine the infrared absorption spectrum of the residue as directed in the liquid film method under Infrared Spectrophotometry <2.25>: it exhibits absorption at the wave numbers of about 2940 cm^{-1} , 2810 cm^{-1} , 2770 cm^{-1} , 1589 cm^{-1} , 1491 cm^{-1} , 1470 cm^{-1} , 1434 cm^{-1} , 1091 cm^{-1} and 1015 cm^{-1} .

Bacterial endotoxins <4.01> Less than 8.8 EU/mg.

Extractable volume <6.05> It meets the requirement.

Foreign insoluble matter <6.06> Perform the test according to Method 1: it meets the requirement.

Insoluble particulate matter <6.07> It meets the requirement.

Sterility <4.06> Perform the test according to the Membrane filtration method: it meets the requirement.

Assay Transfer an exactly measured volume of Chlorpheniramine Maleate Injection, equivalent to about 3 mg of chlorpheniramine maleate ($C_{16}H_{19}ClN_2 \cdot C_4H_4O_4$), to a 100-mL separator, add 20 mL of water and 2 mL of sodium hydroxide TS, and extract with two 50-mL portions of diethyl ether. Combine the diethyl ether extracts, wash with 20 mL of water, and then extract with 20-mL, 20-mL and 5-mL portions of 0.25 mol/L sulfuric acid TS successively. Combine all acid extracts, and add 0.25 mol/L sulfuric acid TS to make exactly 50 mL. Pipet 10 mL of this solution, add 0.25 mol/L sulfuric acid TS to make exactly 25 mL, and use this solution as the sample solution. Separately, weigh accurately about 30 mg of Chlorpheniramine Maleate RS, previously dried at 105°C for 3 hours, and dissolve in water to make exactly 200 mL. Pipet 20 mL of this solution, transfer to a 100-mL separator, add 2 mL of sodium hydroxide TS, and extract with two 50-mL portions of diethyl ether. Proceed in the same manner as for the preparation of the sample solution, and use the solution so obtained as the standard so-

lution. Determine the absorbances A_T and A_S of the sample solution and standard solution at a wavelength of the maximum absorbance at about 265 nm as directed under Ultraviolet-visible Spectrophotometry <2.24>.

Amount (mg) of chlorpheniramine maleate
($C_{16}H_{19}ClN_2 \cdot C_4H_4O_4$)
= $M_S \times A_T / A_S \times 1/10$

M_S : Amount (mg) of Chlorpheniramine Maleate RS taken

Containers and storage Containers—Hermetic containers.
Storage—Light-resistant.

Chlorpheniramine Maleate Powder

クロルフェニラミンマレイン酸塩散

Chlorpheniramine Maleate Powder contains not less than 93.0% and not more than 107.0% of the labeled amount of *dl*-chlorpheniramine maleate ($C_{16}H_{19}ClN_2 \cdot C_4H_4O_4$: 390.86).

Method of preparation Prepare as directed under Granules or Powders, with Chlorpheniramine Maleate.

Identification Weigh a portion of Chlorpheniramine Maleate Powder, equivalent to 50 mg of Chlorpheniramine Maleate, shake with 40 mL of 0.1 mol/L hydrochloric acid TS, and filter. Transfer the filtrate to a separator, and wash with 40 mL of hexane. Add 10 mL of sodium hydroxide TS, and extract with 20 mL of hexane. Wash the hexane layer with 5 mL of water. Centrifuge, if necessary, shake the hexane extract with 0.5 g of anhydrous sodium sulfate for several minutes, and filter. Evaporate the filtrate in a water bath at about 50°C under reduced pressure, and determine the infrared absorption spectrum of the residue as directed in the liquid film method under Infrared Spectrophotometry <2.25>: it exhibits absorption at the wave number of about 2940 cm^{-1} , 2810 cm^{-1} , 2770 cm^{-1} , 1589 cm^{-1} , 1491 cm^{-1} , 1470 cm^{-1} , 1434 cm^{-1} , 1091 cm^{-1} and 1015 cm^{-1} .

Dissolution <6.10> When the test is performed at 50 revolutions per minute according to the Paddle method, using 900 mL of water as the dissolution medium, the dissolution rate in 15 minutes of Chlorpheniramine Maleate Powder is not less than 85%.

Start the test with an accurately weighed amount of Chlorpheniramine Maleate Powder, equivalent to about 4 mg of chlorpheniramine maleate ($C_{16}H_{19}ClN_2 \cdot C_4H_4O_4$), withdraw not less than 20 mL of the medium at the specified minute after starting the test, and filter through a membrane filter with a pore size not exceeding 0.45 μm . Discard not less than 10 mL of the first filtrate, and use the subsequent filtrate as the sample solution. Separately, weigh accurately about 22 mg of Chlorpheniramine Maleate RS, previously dried at 105°C for 3 hours, and dissolve in water to make exactly 100 mL. Pipet 2 mL of this solution, add water to make exactly 100 mL, and use this solution as the standard solution. Perform the test with exactly 50 μL each of the sample solution and standard solution as directed under Liquid Chromatography <2.01> according to the following conditions, and determine the peak areas, A_T and A_S , of chlorpheniramine in each solution.

Dissolution rate (%) with respect to the labeled amount of chlorpheniramine maleate ($C_{16}H_{19}ClN_2 \cdot C_4H_4O_4$)
= $M_S / M_T \times A_T / A_S \times 1/C \times 18$

M_S : Amount (mg) of Chlorpheniramine Maleate RS taken
 M_T : Amount (g) of Chlorpheniramine Maleate Powder taken
 C: Labeled amount (mg) of chlorpheniramine maleate ($C_{16}H_{19}ClN_2 \cdot C_4H_4O_4$) in 1 g

Operating conditions—

Proceed as directed in the operating conditions in the Assay.

System suitability—

System performance: When the procedure is run with 50 μ L of the standard solution under the above operating conditions, the number of theoretical plates and the symmetry factor of the peak of chlorpheniramine are not less than 2000 and not more than 2.5, respectively.

System repeatability: When the test is repeated 6 times with 50 μ L of the standard solution under the above operating conditions, the relative standard deviation of the peak area of chlorpheniramine is not more than 2.0%.

Assay Weigh accurately an amount of Chlorpheniramine Maleate Powder, equivalent to about 4 mg of chlorpheniramine maleate ($C_{16}H_{19}ClN_2 \cdot C_4H_4O_4$), add 70 mL of the internal standard solution, shake for 15 minutes, then add the internal standard solution to make exactly 100 mL, and use this solution as the sample solution. Separately, weigh accurately about 20 mg of Chlorpheniramine Maleate RS, previously dried at 105°C for 3 hours, and add the internal standard to make exactly 100 mL. Pipet 20 mL of this solution, add the internal standard solution to make exactly 100 mL, and use this solution as the standard solution. Perform the test with 30 μ L each of the sample solution and standard solution as directed under Liquid Chromatography <2.01> according to the following conditions, and calculate the ratios, Q_T and Q_S , of the peak area of chlorpheniramine to that of the internal standard.

$$\begin{aligned} & \text{Amount (mg) of chlorpheniramine maleate} \\ & (C_{16}H_{19}ClN_2 \cdot C_4H_4O_4) \\ & = M_S \times Q_T / Q_S \times 1/5 \end{aligned}$$

M_S : Amount (mg) of Chlorpheniramine Maleate RS taken

Internal standard solution—To 7 mL of a solution of methyl parahydroxybenzoate in methanol (1 in 1000) add water to make 1000 mL.

Operating conditions—

Detector: An ultraviolet absorption photometer (wavelength: 265 nm).

Column: A stainless steel column 4.6 mm in inside diameter and 15 cm in length, packed with octadecylsilanized silica gel for liquid chromatography (5 μ m in particle diameter).

Column temperature: A constant temperature of about 40°C.

Mobile phase: Dissolve 1 g of sodium 1-heptane sulfonate in 900 mL of water, add 10 mL of acetic acid (100) and water to make 1000 mL. To 650 mL of this solution add 350 mL of acetonitrile.

Flow rate: Adjust so that the retention time of chlorpheniramine is about 8 minutes.

System suitability—

System performance: When the procedure is run with 30 μ L of the standard solution under the above operating conditions, the internal standard and chlorpheniramine are eluted in this order with the resolution between these peaks being not less than 2.0.

System repeatability: When the test is repeated 6 times with 30 μ L of the standard solution under the above operating conditions, the relative standard deviation of the ratio of

the peak area of chlorpheniramine to that of the internal standard is not more than 1.0%.

Containers and storage Containers—Tight containers.

Chlorpheniramine Maleate Tablets

クロルフェニラミンマレイン酸塩錠

Chlorpheniramine Maleate Tablets contain not less than 93.0% and not more than 107.0% of the labeled amount of *dl*-chlorpheniramine maleate ($C_{16}H_{19}ClN_2 \cdot C_4H_4O_4$; 390.86).

Method of preparation Prepare as directed under Tablets, with Chlorpheniramine Maleate.

Identification Weigh a portion of powdered Chlorpheniramine Maleate Tablets, equivalent to 50 mg of Chlorpheniramine Maleate, shake with 40 mL of 0.1 mol/L hydrochloric acid TS, and filter. Transfer the filtrate to a separator, and wash with 40 mL of hexane. Add 10 mL of sodium hydroxide TS, and extract with 20 mL of hexane. Wash the hexane layer with 5 mL of water. Centrifuge, if necessary, shake the hexane extract with 0.5 g of anhydrous sodium sulfate for several minutes, and filter. Evaporate the filtrate in a water bath at about 50°C under a reduced pressure, and determine the infrared absorption spectrum of the residue as directed in the liquid film method under Infrared Spectrophotometry <2.25>: it exhibits absorption at the wave numbers of about 2940 cm^{-1} , 2810 cm^{-1} , 2770 cm^{-1} , 1589 cm^{-1} , 1491 cm^{-1} , 1470 cm^{-1} , 1434 cm^{-1} , 1091 cm^{-1} and 1015 cm^{-1} .

Uniformity of dosage units <6.02> Perform the test according to the following method: it meets the requirement of the Content uniformity test.

To 1 tablet of Chlorpheniramine Maleate Tablets add 10 mL of water, shake to disintegrate the tablet, then add water to make exactly V mL of a solution containing about 80 μ g of chlorpheniramine maleate ($C_{16}H_{19}ClN_2 \cdot C_4H_4O_4$) per mL, and filter through a membrane filter with a pore size not exceeding 0.5 μ m. Pipet 5 mL of the filtrate, add exactly 2.5 mL of the internal standard solution, add water to make 10 mL, and use this solution as the sample solution. Separately, weigh accurately about 20 mg of Chlorpheniramine Maleate RS, previously dried at 105°C for 3 hours, and add water to make exactly 100 mL. Pipet 20 mL of this solution, add exactly 25 mL of the internal standard solution, add water to make 100 mL, and use this solution as the standard solution. Perform the test with 30 μ L each of the sample solution and standard solution as directed under Liquid Chromatography <2.01> according to the conditions described in the Assay, and calculate the ratios, Q_T and Q_S , of the peak area of chlorpheniramine to that of the internal standard.

$$\begin{aligned} & \text{Amount (mg) of chlorpheniramine maleate} \\ & (C_{16}H_{19}ClN_2 \cdot C_4H_4O_4) \\ & = M_S \times Q_T / Q_S \times V / 250 \end{aligned}$$

M_S : Amount (mg) of Chlorpheniramine Maleate RS taken

Internal standard solution—To 7 mL of a solution of methyl parahydroxybenzoate in methanol (1 in 250) add water to make 1000 mL.

Dissolution <6.10> When the test is performed at 50 revolutions per minute according to the Paddle method, using 900 mL of water as the dissolution medium, the dissolution rate in 45 minutes of Chlorpheniramine Maleate Tablets is not

less than 75%.

Start the test with 1 tablet of Chlorpheniramine Maleate Tablets, withdraw not less than 20 mL of the medium at the specified minute after starting the test, and filter through a membrane filter with a pore size not exceeding 0.45 μm . Discard not less than 10 mL of the first filtrate, pipet V mL of the subsequent filtrate, add water to make exactly V' mL so that each mL contains about 4.4 μg of chlorpheniramine maleate ($\text{C}_{16}\text{H}_{19}\text{ClN}_2\cdot\text{C}_4\text{H}_4\text{O}_4$), and use this solution as the sample solution. Separately, weigh accurately about 22 mg of Chlorpheniramine Maleate RS, previously dried at 105°C for 3 hours, and dissolve in water to make exactly 100 mL. Pipet 2 mL of this solution, add water to make exactly 100 mL, and use this solution as the standard solution. Perform the test with exactly 50 μL each of the sample solution and standard solution as directed under Liquid Chromatography <2.01>, and determine the peak areas, A_T and A_S , of chlorpheniramine in each solution.

Dissolution rate (%) with respect to the labeled amount of chlorpheniramine maleate ($\text{C}_{16}\text{H}_{19}\text{ClN}_2\cdot\text{C}_4\text{H}_4\text{O}_4$)

$$= M_S \times A_T/A_S \times V'/V \times 1/C \times 18$$

M_S : Amount (mg) of Chlorpheniramine Maleate RS taken
 C : Labeled amount (mg) of chlorpheniramine maleate ($\text{C}_{16}\text{H}_{19}\text{ClN}_2\cdot\text{C}_4\text{H}_4\text{O}_4$) in 1 tablet

Operating conditions—

Detector: An ultraviolet absorption photometer (wavelength: 265 nm).

Column: A stainless steel column 4.6 mm in inside diameter and 15 cm in length, packed with octadecylsilanized silica gel for liquid chromatography (5 μm in particle diameter).

Column temperature: A constant temperature of about 40°C.

Mobile phase: Dissolve 1 g of sodium 1-heptane sulfonate in 900 mL of water, add 10 mL of acetic acid (100), and add water to make 1000 mL. To 650 mL of this solution add 350 mL of acetonitrile.

Flow rate: Adjust so that the retention time of chlorpheniramine is about 8 minutes.

System suitability—

System performance: When the procedure is run with 50 μL of the standard solution under the above operating conditions, the number of theoretical plates and the symmetry factor of the peak of chlorpheniramine are not less than 2000 and not more than 2.5, respectively.

System repeatability: When the test is repeated 6 times with 50 μL of the standard solution under the above operating conditions, the relative standard deviation of the peak area of chlorpheniramine is not more than 2.0%.

Assay Weigh accurately the mass of not less than 20 Chlorpheniramine Maleate Tablets, and powder. Weigh accurately a portion of the powder, equivalent to about 4 mg of chlorpheniramine maleate ($\text{C}_{16}\text{H}_{19}\text{ClN}_2\cdot\text{C}_4\text{H}_4\text{O}_4$), add 70 mL of the internal standard solution, shake for 15 minutes, then add the internal standard solution to make exactly 100 mL, filter through a membrane filter with a pore size not exceeding 0.5 μm , and use this solution as the sample solution. Separately, weigh accurately about 20 mg of Chlorpheniramine Maleate RS, previously dried at 105°C for 3 hours, and add the internal standard to make exactly 100 mL. Pipet 20 mL of this solution, add the internal standard solution to make exactly 100 mL, and use this solution as the standard solution. Perform the test with 30 μL each of the sample solution and standard solution as directed under Liquid Chromatography <2.01> according to the following conditions, and calculate the ratios, Q_T and Q_S , of the peak area of

chlorpheniramine to that of the internal standard.

Amount (mg) of chlorpheniramine maleate ($\text{C}_{16}\text{H}_{19}\text{ClN}_2\cdot\text{C}_4\text{H}_4\text{O}_4$)

$$= M_S \times Q_T/Q_S \times 1/5$$

M_S : Amount (mg) of Chlorpheniramine Maleate RS taken

Internal standard solution—To 7 mL of a solution of methyl parahydroxybenzoate in methanol (1 in 1000) add water to make 1000 mL.

Operating conditions—

Detector: An ultraviolet absorption photometer (wavelength: 265 nm).

Column: A stainless steel column 4.6 mm in inside diameter and 15 cm in length, packed with octadecylsilanized silica gel for liquid chromatography (5 μm in particle diameter).

Column temperature: A constant temperature of about 40°C.

Mobile phase: Dissolve 1 g of sodium 1-heptane sulfonate in 900 mL of water, add 10 mL of acetic acid (100) and water to make 1000 mL. To 650 mL of this solution add 350 mL of acetonitrile.

Flow rate: Adjust so that the retention time of chlorpheniramine is about 8 minutes.

System suitability—

System performance: When the procedure is run with 30 μL of the standard solution under the above operating conditions, the internal standard and chlorpheniramine are eluted in this order with the resolution between these peaks being not less than 2.0.

System repeatability: When the test is repeated 6 times with 30 μL of the standard solution under the above operating conditions, the relative standard deviation of the ratio of the peak area of chlorpheniramine to that of the internal standard is not more than 1.0%.

Containers and storage Containers—Tight containers.

d-Chlorpheniramine Maleate

d-クロルフェニラミンマレイン酸塩

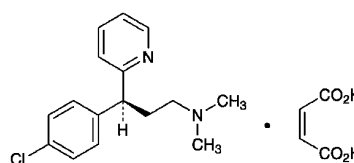

$\text{C}_{16}\text{H}_{19}\text{ClN}_2\cdot\text{C}_4\text{H}_4\text{O}_4$: 390.86
 (3*S*)-3-(4-Chlorophenyl)-*N,N*-dimethyl-3-pyridin-2-ylpropylamine monomaleate
 [2438-32-6]

d-Chlorpheniramine Maleate, when dried, contains not less than 99.0% and not more than 101.0% of *d*-chlorpheniramine maleate ($\text{C}_{16}\text{H}_{19}\text{ClN}_2\cdot\text{C}_4\text{H}_4\text{O}_4$).

Description *d*-Chlorpheniramine Maleate occurs as a white crystalline powder.

It is very soluble in water, in methanol and in acetic acid (100), and freely soluble in *N,N*-dimethylformamide and in ethanol (99.5).

It dissolves in dilute hydrochloric acid.

Identification (1) Determine the absorption spectrum of a solution of *d*-Chlorpheniramine Maleate in 0.1 mol/L hydrochloric acid TS (3 in 100,000) as directed under Ultraviolet-visible Spectrophotometry <2.24>, and compare the

spectrum with the Reference Spectrum: both spectra exhibit similar intensities of absorption at the same wavelengths.

(2) Determine the infrared absorption spectrum of *d*-Chlorpheniramine Maleate, previously dried, as directed in the paste method under Infrared Spectrophotometry <2.25>, and compare the spectrum with the Reference Spectrum: both spectra exhibit similar intensities of absorption at the same wave numbers.

(3) Dissolve 0.10 g of *d*-Chlorpheniramine Maleate in 5 mL of methanol, and use this solution as the sample solution. Separately, dissolve 56 mg of maleic acid in 10 mL of methanol, and use this solution as the standard solution. Perform the test with these solutions as directed under Thin-layer Chromatography <2.03>. Spot 5 μ L each of the sample solution and standard solution on a plate of silica gel for thin-layer chromatography. Develop the plate with a mixture of diethyl ether, methanol, acetic acid (100) and water (70:20:7:3) to a distance of about 12 cm, and air-dry the plate. Examine under ultraviolet light (main wavelength: 254 nm): a spot among two of the spots obtained with the sample solution shows the same intense to the spot obtained with the standard solution, and its *R_f* value is about 0.4.

Optical rotation <2.49> $[\alpha]_D^{20}$: +39.5 – +43.0° (after drying, 0.5 g, *N,N*-dimethylformamide, 10 mL, 100 mm).

pH <2.54> Dissolve 1.0 g of *d*-Chlorpheniramine Maleate in 100 mL of freshly boiled and cooled water: the pH of this solution is between 4.0 and 5.0.

Melting point <2.60> 111 – 115°C

Purity (1) Clarity and color of solution—Dissolve 1.0 g of *d*-Chlorpheniramine Maleate in 50 mL of water: the solution is clear and colorless.

(2) Heavy metals <1.07>—Proceed with 1.0 g of *d*-Chlorpheniramine Maleate according to Method 4 and perform the test. Prepare the control solution with 2.0 mL of Standard Lead Solution (not more than 20 ppm).

(3) Related substances—Dissolve 0.10 g of *d*-Chlorpheniramine Maleate in 100 mL of the mobile phase, and use this solution as the sample solution. Pipet 3 mL of the sample solution, add the mobile phase to make exactly 100 mL. Pipet 2 mL of this solution, add the mobile phase to make exactly 20 mL, and use this solution as the standard solution. Perform the test with exactly 20 μ L each of the sample solution and standard solution as directed under Liquid Chromatography <2.01> according to the following conditions, and determine each peak area by the automatic integration method: the area of the peak other than maleic acid and *d*-chlorpheniramine obtained from the sample solution is not larger than 2/3 times the peak area of *d*-chlorpheniramine from the standard solution, and the total area of these peaks is not larger than the peak area of *d*-chlorpheniramine from the standard solution.

Operating conditions—

Detector: An ultraviolet absorption photometer (wavelength: 225 nm).

Column: A stainless steel column 3.9 mm in inside diameter and 30 cm in length, packed with octadecylsilanized silica gel for liquid chromatography (10 μ m in particle diameter).

Column temperature: A constant temperature of about 25°C.

Mobile phase: Dissolve 8.57 g of ammonium dihydrogen phosphate and 1 mL of phosphoric acid in water to make 1000 mL. To 800 mL of this solution add 200 mL of acetonitrile.

Flow rate: Adjust so that the retention time of *d*-chlorpheniramine is about 11 minutes.

Time span of measurement: About 4 times as long as the retention time of *d*-chlorpheniramine, beginning after the solvent peak.

System suitability—

Test for required detectability: To exactly 2.5 mL of the standard solution add the mobile phase to make exactly 25 mL. Confirm that the peak area of *d*-chlorpheniramine obtained with 20 μ L of this solution is equivalent to 7 to 13% of that with 20 μ L of the standard solution.

System performance: When the procedure is run with 20 μ L of the standard solution under the above operating conditions, the number of theoretical plates and the symmetry factor of the peak of *d*-chlorpheniramine are not less than 4000 and not more than 2.0, respectively.

System repeatability: When the test is repeated 6 times with 20 μ L of the standard solution under the above operating conditions, the relative standard deviation of the peak area of *d*-chlorpheniramine is not more than 4.0%.

Loss on drying <2.41> Not more than 0.5% (1 g, 65°C, 4 hours).

Residue on ignition <2.44> Not more than 0.1% (1 g).

Assay Weigh accurately about 0.3 g of *d*-Chlorpheniramine Maleate, previously dried, and dissolve in 20 mL of acetic acid (100). Titrate <2.50> with 0.1 mol/L perchloric acid VS until the color of the solution changes from purple through blue-green to green (indicator: 2 drops of crystal violet TS). Perform a blank determination in the same manner, and make any necessary correction.

Each mL of 0.1 mol/L perchloric acid VS
= 19.54 mg of C₁₇H₁₉ClN₂·C₄H₄O₄

Containers and storage Containers—Tight containers.

Storage—Light-resistant.

Chlorpromazine Hydrochloride

クロルプロマジン塩酸塩

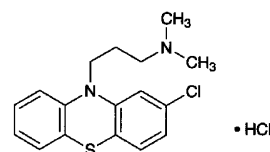

C₁₇H₁₉ClN₂S·HCl: 355.33

3-(2-Chloro-10*H*-phenothiazin-10-yl)-*N,N*-dimethylpropylamine monohydrochloride
[69-09-0]

Chlorpromazine Hydrochloride, when dried, contains not less than 99.0% of chlorpromazine hydrochloride (C₁₇H₁₉ClN₂S·HCl).

Description Chlorpromazine Hydrochloride occurs as a white to pale yellow crystalline powder. It is odorless, or has a faint, characteristic odor.

It is very soluble in water, freely soluble in ethanol (95) and in acetic acid (100), sparingly soluble in acetic anhydride, and practically insoluble in diethyl ether.

It is gradually colored by light.

Identification (1) To 5 mL of a solution of Chlorpromazine Hydrochloride (1 in 1000) add 1 drop of iron (III) chloride TS: a red color develops.

(2) Dissolve 0.1 g of Chlorpromazine Hydrochloride in

20 mL of water and 3 drops of dilute hydrochloric acid, add 10 mL of 2,4,6-trinitrophenol TS, and allow to stand for 5 hours. Collect the resulting precipitate, wash with water, recrystallize from a small portion of acetone, and dry at 105°C for 1 hour: the crystals so obtained melt <2.60> between 175°C and 179°C.

(3) Dissolve 0.5 g of Chlorpromazine Hydrochloride in 5 mL of water, add 2 mL of ammonia TS, and heat on a water bath for 5 minutes. Cool, filter, and render the filtrate acidic with dilute nitric acid: the solution responds to Qualitative Tests <1.09> (2) for chloride.

Melting point <2.60> 196 – 200°C

pH <2.54> Dissolve 1.0 g of Chlorpromazine Hydrochloride in 20 mL of freshly boiled and cooled water, and measure within 10 minutes: the pH of this solution is between 4.0 and 5.0.

Purity (1) Clarity and color of solution—A solution of 1.0 g of Chlorpromazine Hydrochloride in 20 mL of water, when observed within 10 minutes, is clear and colorless to pale yellow.

(2) Heavy metals <1.07>—Proceed with 1.0 g of Chlorpromazine Hydrochloride according to Method 2, and perform the test. Prepare the control solution with 2.0 mL of Standard Lead Solution (not more than 20 ppm).

Loss on drying <2.41> Not more than 0.5% (1 g, 105°C, 2 hours).

Residue on ignition <2.44> Not more than 0.1% (1 g).

Assay Weigh accurately about 0.7 g of Chlorpromazine Hydrochloride, previously dried, dissolve in 50 mL of a mixture of acetic anhydride and acetic acid (100) (7:3), and titrate <2.50> with 0.1 mol/L perchloric acid VS (potentiometric titration). Perform a blank determination in the same manner, and make any necessary correction.

Each mL of 0.1 mol/L perchloric acid VS
= 35.53 mg of C₁₇H₁₉ClN₂S.HCl

Containers and storage Containers—Tight containers.
Storage—Light-resistant.

Chlorpromazine Hydrochloride Injection

クロルプロマジン塩酸塩注射液

Chlorpromazine Hydrochloride Injection is an aqueous injection.

It contains not less than 95.0% and not more than 105.0% of the labeled amount of chlorpromazine hydrochloride (C₁₇H₁₉ClN₂S.HCl: 355.33).

Method of preparation Prepare as directed under Injections, with Chlorpromazine Hydrochloride.

Description Chlorpromazine Hydrochloride Injection is a clear, colorless or pale yellow liquid.

pH: 4.0 – 6.5

Identification (1) Proceed with a volume of Chlorpromazine Hydrochloride Injection, equivalent to 5 mg of Chlorpromazine Hydrochloride, as directed in the Identification (1) under Chlorpromazine Hydrochloride.

(2) Proceed with a volume of Chlorpromazine Hydrochloride Injection, equivalent to 0.1 g of Chlorpromazine

Hydrochloride, as directed in the Identification (2) under Chlorpromazine Hydrochloride.

Extractable volume <6.05> It meets the requirement.

Foreign insoluble matter <6.06> Perform the test according to Method 1: it meets the requirement.

Insoluble particulate matter <6.07> It meets the requirement.

Sterility <4.06> Perform the test according to the Membrane filtration method: it meets the requirement.

Assay Transfer an exactly measured volume of Chlorpromazine Hydrochloride Injection, equivalent to about 0.15 g of chlorpromazine hydrochloride (C₁₇H₁₉ClN₂S.HCl) to a separator, add 30 mL of water and 10 mL of a solution of sodium hydroxide (1 in 5), and extract with two 30-mL portions and three 20-mL portions of diethyl ether. Wash the combined diethyl ether extracts with successive 10-mL portions of water until the last washing shows no red color upon the addition of phenolphthalein TS. Concentrate the diethyl ether extracts on a water bath to 20 mL, add 5 g of anhydrous sodium sulfate, allow to stand for 20 minutes, and filter through a pledget of absorbent cotton. Wash with diethyl ether, combine the washings with the filtrate, and evaporate the diethyl ether on a water bath. Dissolve the residue in 50 mL of acetone and 5 mL of acetic acid (100), and titrate <2.50> with 0.05 mol/L perchloric acid VS until the color of the solution changes from red-purple to blue-purple (indicator: 3 drops of bromocresol green-methylrosaniline chloride TS). Perform a blank determination in the same manner, and make any necessary correction.

Each mL of 0.05 mol/L perchloric acid VS
= 17.77 mg of C₁₇H₁₉ClN₂S.HCl

Containers and storage Containers—Hermetic containers, and colored containers may be used.

Storage—Light-resistant.

Chlorpromazine Hydrochloride Tablets

クロルプロマジン塩酸塩錠

Chlorpromazine Hydrochloride Tablets contain not less than 93.0% and not more than 107.0% of the labeled amount of chlorpromazine hydrochloride (C₁₇H₁₉ClN₂S.HCl: 355.33).

Method of preparation Prepare as directed under Tablets, with Chlorpromazine Hydrochloride.

Identification (1) Shake a quantity of powdered Chlorpromazine Hydrochloride Tablets, equivalent to 0.2 g of Chlorpromazine Hydrochloride, with 40 mL of 0.1 mol/L hydrochloric acid TS, and filter. To 1 mL of the filtrate add 4 mL of water and 1 drop of iron (III) chloride TS: a red color develops.

(2) To 20 mL of the filtrate obtained in (1) add 10 mL of 2,4,6-trinitrophenol TS dropwise, and proceed as directed in the Identification (2) under Chlorpromazine Hydrochloride.

Uniformity of dosage units <6.02> Perform the test according to the following method: it meets the requirement of the Content uniformity test.

Conduct this procedures using light-resistant vessels. To 1 tablet of Chlorpromazine Hydrochloride Tablets add an

amount of a mixture of diluted phosphoric acid (1 in 500) and ethanol (99.5) (1:1) so that each mL contains about 0.83 mg of chlorpromazine hydrochloride ($C_{17}H_{19}ClN_2S.HCl$), sonicate for 5 minutes, then shake vigorously for 20 minutes, and add the mixture of diluted phosphoric acid (1 in 500) and ethanol (99.5) (1:1) to make exactly V mL so that each mL contains about 0.5 mg of chlorpromazine hydrochloride ($C_{17}H_{19}ClN_2S.HCl$). Filter through a membrane filter with a pore size not exceeding $0.45 \mu m$. Discard the first 3 mL of the filtrate, pipet 2.5 mL of the subsequent filtrate, add exactly 5 mL of the internal standard solution, then add the mixture of diluted phosphoric acid (1 in 500) and ethanol (99.5) (1:1) to make 25 mL, and use this solution as the sample solution. Then, proceed as directed in the Assay.

$$\begin{aligned} & \text{Amount (mg) of chlorpromazine hydrochloride} \\ & (C_{17}H_{19}ClN_2S.HCl) \\ & = M_S \times Q_T/Q_S \times V/50 \end{aligned}$$

M_S : Amount (mg) of chlorpromazine hydrochloride for assay taken

Internal standard solution—A solution of ethyl parahydroxybenzoate in the mixture of diluted phosphoric acid (1 in 500) and ethanol (99.5) (1:1) (1 in 4500).

Dissolution <6.10> When the test is performed at 75 revolutions per minute according to the Paddle method, using 900 mL of 2nd fluid for dissolution test as the dissolution medium, the dissolution rate in 60 minutes of Chlorpromazine Hydrochloride Tablets is not less than 75%.

Start the test with 1 tablet of Chlorpromazine Hydrochloride Tablets, withdraw not less than 20 mL of the medium at the specified minute after starting the test, and filter through a membrane filter with a pore size not exceeding $0.8 \mu m$. Discard not less than 10 mL of the first filtrate, pipet V mL of the subsequent filtrate, add the dissolution medium to make exactly V' mL so that each mL contains about $5.6 \mu g$ of chlorpromazine hydrochloride ($C_{17}H_{19}ClN_2S.HCl$), and use this solution as the sample solution. Separately, weigh accurately about 90 mg of chlorpromazine hydrochloride for assay, previously dried at $105^\circ C$ for 2 hours, dissolve in the dissolution medium to make exactly 200 mL. Pipet 5 mL of this solution, add the dissolution medium to make exactly 100 mL, further pipet 5 mL of this solution, add the dissolution medium to make exactly 20 mL, and use this solution as the standard solution. Determine the absorbances, A_T and A_S , of the sample solution and standard solution at 254 nm as directed under Ultraviolet-visible Spectrophotometry <2.24>.

$$\begin{aligned} & \text{Dissolution rate (\%)} \text{ with respect to labeled amount} \\ & \text{of chlorpromazine hydrochloride } (C_{17}H_{19}ClN_2S.HCl) \\ & = M_S \times A_T/A_S \times V'/V \times 1/C \times 45/8 \end{aligned}$$

M_S : Amount (mg) of chlorpromazine hydrochloride for assay taken

C : Labeled amount (mg) of chlorpromazine hydrochloride ($C_{17}H_{19}ClN_2S.HCl$) in 1 tablet

Assay Conduct this procedure without exposure to light, using light-resistant vessels. Weigh accurately, and powder not less than 20 Chlorpromazine Hydrochloride Tablets. Weigh accurately a portion of the powder, equivalent to about 50 mg of chlorpromazine hydrochloride ($C_{17}H_{19}ClN_2S.HCl$), add 60 mL of a mixture of diluted phosphoric acid (1 in 500) and ethanol (99.5) (1:1), sonicate for 5 minutes, then shake vigorously for 20 minutes, and add the mixture of diluted phosphoric acid (1 in 500) and ethanol (99.5) (1:1) to make exactly 100 mL. Filter the solution through a membrane filter with a pore size not exceeding

$0.45 \mu m$, and discard the first 3 mL of the filtrate. To exactly 2.5 mL of the subsequent filtrate add exactly 5 mL of the internal standard solution, then add the mixture of diluted phosphoric acid (1 in 500) and ethanol (99.5) (1:1) to make 25 mL, and use this solution as the sample solution. Separately, weigh accurately about 25 mg of chlorpromazine hydrochloride for assay, previously dried at $105^\circ C$ for 2 hours, and dissolve in the mixture of diluted phosphoric acid (1 in 500) and ethanol (99.5) (1:1) to make exactly 100 mL. Pipet 5 mL of this solution, add exactly 5 mL of the internal standard solution and the mixture of diluted phosphoric acid (1 in 500) and ethanol (99.5) (1:1) to make 25 mL, and use this solution as the standard solution. Perform the test with $10 \mu L$ each of the sample solution and standard solution as directed under Liquid Chromatography <2.01> according to the following conditions, and calculate the ratios, Q_T and Q_S , of the peak area of chlorpromazine to that of the internal standard.

$$\begin{aligned} & \text{Amount (mg) of chlorpromazine hydrochloride} \\ & (C_{17}H_{19}ClN_2S.HCl) = M_S \times Q_T/Q_S \times 2 \end{aligned}$$

M_S : Amount (mg) of chlorpromazine hydrochloride for assay taken

Internal standard solution—A solution of ethyl parahydroxybenzoate in a mixture of diluted phosphoric acid (1 in 500) and ethanol (99.5) (1:1) (1 in 4500).

Operating conditions—

Detector: An ultraviolet absorption photometer (wavelength: 256 nm).

Column: A stainless steel column 4.6 mm in inside diameter and 15 cm in length, packed with octadecylsilanized silica gel for liquid chromatography ($5 \mu m$ in particle diameter).

Column temperature: A constant temperature of about $25^\circ C$.

Mobile phase: A mixture of diluted 0.05 mol/L sodium dihydrogen phosphate TS (1 in 2) and acetonitrile (27:13).

Flow rate: Adjust so that the retention time of chlorpromazine is about 15 minutes.

System suitability—

System performance: When the procedure is run with $10 \mu L$ of the standard solution under the above operating conditions, the internal standard and chlorpromazine are eluted in this order with the resolution between these peaks being not less than 10.

System repeatability: When the test is repeated 6 times with $10 \mu L$ of the standard solution under the above operating conditions, the relative standard deviation of the ratio of the peak area of chlorpromazine to that of the internal standard is not more than 1.0%.

Containers and storage Containers—Tight containers.

Storage—Light-resistant.

Chlorpropamide

クロルプロパミド

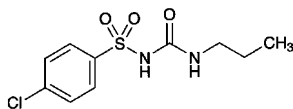

$C_{10}H_{13}ClN_2O_3S$: 276.74

4-Chloro-*N*-(propylcarbamoyl)benzenesulfonamide
[94-20-2]

Chlorpropamide, when dried, contains not less than 98.0% of chlorpropamide ($C_{10}H_{13}ClN_2O_3S$).

Description Chlorpropamide occurs as white, crystals or crystalline powder.

It is freely soluble in methanol and in acetone, soluble in ethanol (95), and slightly soluble in diethyl ether, and practically insoluble in water.

Identification (1) Dissolve 0.08 g of Chlorpropamide in 50 mL of methanol. To 1 mL of the solution add 0.01 mol/L hydrochloric acid TS to make 200 mL. Determine the absorption spectrum of the solution as directed under Ultraviolet-visible Spectrophotometry <2.24>, and compare the spectrum with the Reference Spectrum: both spectra exhibit similar intensities of absorption at the same wavelengths.

(2) Determine the infrared absorption spectrum of Chlorpropamide, previously dried, as directed in the potassium bromide disk method under Infrared Spectrophotometry <2.25>, and compare the spectrum with the Reference Spectrum: both spectra exhibit similar intensities of absorption at the same wave numbers.

(3) Perform the test with Chlorpropamide as directed under Flame Coloration Test <1.04> (2): a green color appears.

Melting point <2.60> 127 – 131°C

Purity (1) Acidity—To 3.0 g Chlorpropamide add 150 mL of water, and warm at 70°C for 5 minutes. Allow to stand in ice water for 1 hour, and filter. To 25 mL of the filtrate add 2 drops of methyl red TS and 0.30 mL of 0.1 mol/L sodium hydroxide VS: a yellow color develops.

(2) Chloride <1.03>—To 40 mL of the filtrate obtained in (1) add 6 mL of dilute nitric acid and water to make 50 mL. Perform the test using this solution as the test solution. Prepare the control solution with 0.25 mL of 0.01 mol/L hydrochloric acid VS (not more than 0.011%).

(3) Sulfate <1.14>—To 40 mL of the filtrate obtained in (1) add 1 mL of dilute hydrochloric acid and water to make 50 mL. Perform the test using this solution as the test solution. Prepare the control solution with 0.35 mL of 0.005 mol/L sulfuric acid VS (not more than 0.021%).

(4) Heavy metals <1.07>—Proceed with 2.0 g of Chlorpropamide according to Method 2, and perform the test. Prepare the control solution with 2.0 mL of Standard Lead Solution (not more than 10 ppm).

(5) Related substances—Dissolve 0.6 g of Chlorpropamide in acetone to make exactly 10 mL, and use this solution as the sample solution. Pipet 1 mL of the sample solution, add acetone to make exactly 300 mL, and use this solution as the standard solution (1). Separately, dissolve 60 mg of 4-chlorobenzene sulfonamide in acetone to make exactly 300 mL, and use this solution as the standard solution (2). Perform the test with these solutions as directed under

Thin-layer Chromatography <2.03>. Spot 5 μ L each of the sample solution and standard solutions (1) and (2) on a plate of silica gel for thin-layer chromatography. Develop the plate with a mixture of cyclohexane, 3-methyl-1-butanol, methanol and ammonia solution (28) (15:10:5:1) to a distance of about 10 cm, and air-dry the plate. After drying the plate at 100°C for 1 hour, spray evenly sodium hypochlorite TS on the plate, and air-dry for 15 minutes. Then spray evenly potassium iodide-starch TS on the plate: the spot obtained from the sample solution equivalent to the spot from the standard solution (2) is not more intense than the spot from the standard solution (2), and the spots other than the spot mentioned above and other than the principal spot is not more intense than the spot from the standard solution (1).

Loss on drying <2.41> Not more than 0.5% (1 g, 105°C, 3 hours).

Residue on ignition <2.44> Not more than 0.2% (1 g).

Assay Weigh accurately about 0.5 g of Chlorpropamide, previously dried, dissolve in 30 mL of neutralized ethanol, and add 20 mL of water. Titrate <2.50> with 0.1 mol/L sodium hydroxide VS (indicator: 3 drops of phenolphthalein TS).

Each mL of 0.1 mol/L sodium hydroxide VS
= 27.67 mg of $C_{10}H_{13}ClN_2O_3S$

Containers and storage Containers—Well-closed containers.

Chlorpropamide Tablets

クロルプロパミド錠

Chlorpropamide Tablets contain not less than 95.0% and not more than 105.0% of the labeled amount of chlorpropamide ($C_{10}H_{13}ClN_2O_3S$: 276.74).

Method of preparation Prepare as directed under Tablets, with Chlorpropamide.

Identification Take a quantity of powdered Chlorpropamide Tablets, equivalent to 0.08 g of Chlorpropamide, add 50 mL of methanol, shake, and filter. To 1 mL of the filtrate add 0.01 mol/L hydrochloric acid TS to make 200 mL, and determine the absorption spectrum of this solution as directed under Ultraviolet-visible Spectrophotometry <2.24>: it exhibits a maximum between 231 nm and 235 nm.

Uniformity of dosage units <6.02> Perform the test according to the following method: it meets the requirement of the Content uniformity test.

To 1 tablet of Chlorpropamide Tablets add 75 mL of the mobile phase, sonicate for 20 minutes with occasional strong shaking, then add the mobile phase to make exactly V mL so that each mL contains about 2.5 mg of Chlorpropamide. Centrifuge the solution, pipet 2 mL of the supernatant liquid, add the mobile phase to make exactly 100 mL, and use this solution as the sample solution. Then, proceed as directed in the Assay.

Amount (mg) of chlorpropamide ($C_{10}H_{13}ClN_2O_3S$)
= $M_S \times A_T / A_S \times V / 20$

M_S : Amount (mg) of chlorpropamide for assay taken

Dissolution <6.10> When the test is performed at 50 revolutions per minute according to the Paddle method, using 900

mL of 2nd fluid for dissolution test as the dissolution medium, the dissolution rate in 45 minutes of Chlorpropamide Tablets is not less than 70%.

Start the test with 1 tablet of Chlorpropamide Tablets, withdraw not less than 20 mL of the medium at the specified minute after starting the test, and filter through a membrane filter with a pore size not exceeding 0.8 μm . Discard not less than 10 mL of the first filtrate, pipet V mL of the subsequent filtrate, add the dissolution medium to make exactly V' mL so that each mL contains about 10 μg of chlorpropamide ($\text{C}_{10}\text{H}_{13}\text{ClN}_2\text{O}_3\text{S}$), and use this solution as the sample solution. Separately, weigh accurately about 50 mg of chlorpropamide for assay, previously dried at 105°C for 3 hours, dissolve in 10 mL of methanol, and add water to make exactly 50 mL. Pipet 1 mL of this solution, add the dissolution medium to make exactly 100 mL, and use this solution as the standard solution. Determine the absorbances, A_T and A_S , of the sample solution and standard solution at 232 nm as directed under Ultraviolet-visible Spectrophotometry <2.24>.

Dissolution rate (%) with respect to the labeled amount of chlorpropamide ($\text{C}_{10}\text{H}_{13}\text{ClN}_2\text{O}_3\text{S}$)

$$= M_S \times A_T / A_S \times V' / V \times 1 / C \times 18$$

M_S : Amount (mg) of chlorpropamide for assay taken
 C : Labeled amount (mg) of chlorpropamide ($\text{C}_{10}\text{H}_{13}\text{ClN}_2\text{O}_3\text{S}$) in 1 tablet

Assay Weigh accurately and powder not less than 20 Chlorpropamide Tablets. Weigh accurately a quantity of the powder, equivalent to about 50 mg of chlorpropamide ($\text{C}_{10}\text{H}_{13}\text{ClN}_2\text{O}_3\text{S}$), add 75 mL of the mobile phase, shake for 10 minutes, and add the mobile phase to make exactly 100 mL. Centrifuge this solution, pipet 10 mL of the supernatant liquid, add the mobile phase to make exactly 100 mL, and use this solution as the sample solution. Separately, weigh accurately about 50 mg of chlorpropamide for assay, previously dried at 105°C for 3 hours, dissolve in the mobile phase to make exactly 100 mL. Pipet 10 mL of this solution, add the mobile phase to make exactly 100 mL, and use this solution as the standard solution. Perform the test with exactly 20 μL each of the sample solution and standard solution as directed under Liquid Chromatography <2.01> according to the following conditions. Determine the peak areas, A_T and A_S , of chlorpropamide in each solution.

Amount (mg) of chlorpropamide ($\text{C}_{10}\text{H}_{13}\text{ClN}_2\text{O}_3\text{S}$)

$$= M_S \times A_T / A_S$$

M_S : Amount (mg) of chlorpropamide for assay taken

Operating conditions—

Detector: An ultraviolet absorption photometer (wavelength: 240 nm).

Column: A stainless steel column 4.6 mm in inside diameter and 25 cm in length, packed with octadecylsilanized silica gel for liquid chromatography (10 μm in particle diameter).

Column temperature: A constant temperature of about 25°C.

Mobile phase: A mixture of diluted acetic acid (100) (1 in 100) and acetonitrile (1:1).

Flow rate: Adjust so that the retention time of chlorpropamide is about 5 minutes.

System suitability—

System performance: When the procedure is run with 20 μL of the standard solution under the above operating conditions, the number of theoretical plates and the symmetry factor of the peak of chlorpropamide are not less than 1500 and not more than 1.5, respectively.

System repeatability: When the test is repeated 6 times

with 20 μL of the standard solution under the above operating conditions, the relative standard deviation of the peak area of chlorpropamide is not more than 1.5%.

Containers and storage Containers—Well-closed containers.

Cholecalciferol

Vitamin D₃

コレカルシフェロール

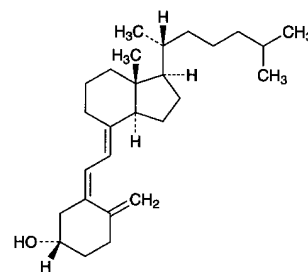

$\text{C}_{27}\text{H}_{44}\text{O}$: 384.64
 (3*S*,5*Z*,7*E*)-9,10-Secocholesta-5,7,10(19)-trien-3-ol
 [67-97-0]

Cholecalciferol contains not less than 97.0% and not more than 103.0% of cholecalciferol ($\text{C}_{27}\text{H}_{44}\text{O}$).

Description Cholecalciferol occurs as white crystals. It is odorless.

It is freely soluble in ethanol (95), in chloroform, in diethyl ether and in isooctane, and practically insoluble in water.

It is affected by air and by light.

Melting point: 84 – 88°C Transfer Cholecalciferol to a capillary tube, and dry for 3 hours in a desiccator (in vacuum at a pressure not exceeding 2.67 kPa). Immediately fireseal the capillary tube, put it in a bath fluid, previously heated to a temperature about 10°C below the expected melting point, and heat at a rate of rise of about 3°C per minute, and read the melting point.

Identification (1) Dissolve 0.5 mg of Cholecalciferol in 5 mL of chloroform, add 0.3 mL of acetic anhydride and 0.1 mL of sulfuric acid, and shake: a red color is produced, and rapidly changes through purple and blue to green.

(2) Determine the infrared absorption spectrum of Cholecalciferol as directed in the potassium bromide disk method under Infrared Spectrophotometry <2.25>, and compare the spectrum with the Reference Spectrum or the spectrum of Cholecalciferol RS: both spectra exhibit similar intensities of absorption at the same wave numbers.

Absorbance <2.24> $E_{1\text{cm}}^{1\%}$ (265 nm): 450 – 490 (10 mg, ethanol (95), 1000 mL).

Optical rotation <2.49> $[\alpha]_D^{20}$ +103 – +112° (50 mg, ethanol (95), 10 mL, 100 mm). Prepare the solution without delay, using Cholecalciferol from a container opened not longer than 30 minutes, previously, and determine the rotation within 30 minutes after the solution has been prepared.

Purity 7-Dehydrocholesterol—Dissolve 10 mg of Cholecalciferol in 2.0 mL of diluted ethanol (95) (9 in 10), add a solution prepared by dissolving 20 mg of digitonin in 2.0 mL of diluted ethanol (95) (9 in 10), and allow the mixture to stand for 18 hours: no precipitate is formed.

Assay Proceed with the operation avoiding contact with air or other oxidizing agents and using light-resistant containers. Dissolve separately about 30 mg each of Cholecalciferol and Cholecalciferol RS, accurately weighed, in isooctane to make exactly 50 mL. Pipet 10 mL each of these solutions, add 3 mL each of the internal standard solution, then add the mobile phase to make 50 mL, and use these solutions as the sample solution and the standard solution. Perform the test with 10 μ L each of the sample solution and standard solution as directed under Liquid Chromatography <2.01> according to the following conditions, and calculate the ratios, Q_T and Q_S , of the peak area of cholecalciferol to that of the internal standard.

Amount (mg) of cholecalciferol ($C_{27}H_{44}O = M_S \times Q_T/Q_S$)

M_S : Amount (mg) of Cholecalciferol RS taken

Internal standard solution—A solution of dimethyl phthalate in isooctane (1 in 100).

Operating conditions—

Detector: An ultraviolet absorption photometer (wavelength: 254 nm).

Column: A stainless steel column about 4 mm in inside diameter and 10 to 30 cm in length, packed with silica gel for liquid chromatography (5 to 10 μ m in particle diameter).

Column temperature: Ordinary temperature.

Mobile phase: A mixture of hexane and *n*-amylalcohol (997:3).

Flow rate: Adjust so that the retention time of cholecalciferol is about 25 minutes.

Selection of column: Dissolve 15 mg of Cholecalciferol RS in 25 mL of isooctane. Transfer this solution to a flask, heat under a reflux condenser in an oil bath for 2 hours, and cool to room temperature rapidly. Transfer this solution to a quartz test tube, and irradiate under a short-wave lamp (main wavelength: 254 nm) and a long-wave lamp (main wavelength: 365 nm) for 3 hours. To this solution add the mobile phase to make 50 mL. Proceed with 10 μ L of this solution under the above operating conditions. Use a column with the relative retention time of previtamin D₃, trans-vitamin D₃ and tachysterol D₃ to cholecalciferol being about 0.5, about 0.6 and about 1.1, respectively, and with resolution between previtamin D₃ and trans-vitamin D₃, and that between cholecalciferol and tachysterol D₃ being not less than 1.0.

Containers and storage Containers—Hermetic containers.

Storage—Light-resistant, under nitrogen atmosphere, and in a cold place.

Cholesterol

コレステロール

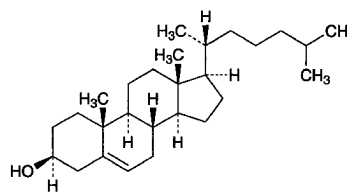

$C_{27}H_{46}O$: 386.65

Cholest-5-en-3 β -ol
[57-88-5]

Description Cholesterol occurs as white to pale yellow, crystals or grains. It is odorless, or has a slight odor. It is tasteless.

It is freely soluble in chloroform and in diethyl ether, sparingly soluble in ethanol (99.5) and in acetone, and practically insoluble in water.

It gradually changes to a yellow to light yellow-brown color by light.

Identification (1) Dissolve 0.01 g of Cholesterol in 1 mL of chloroform, add 1 mL of sulfuric acid, and shake: a red color develops in the chloroform layer, and the sulfuric acid layer shows a green fluorescence.

(2) Dissolve 5 mg of Cholesterol in 2 mL of chloroform, add 1 mL of acetic anhydride and 1 drop of sulfuric acid, and shake: a red color is produced, and it changes to green through blue.

Optical rotation <2.49> $[\alpha]_D^{25}$: $-29 - -36^\circ$ (after drying, 0.2 g, acetone, 10 mL, 100 mm).

Melting point <2.60> 147 – 150°C

Purity (1) Clarity of solution—Place 0.5 g of Cholesterol in a glass-stoppered flask, dissolve in 50 mL of warm ethanol (95), and allow to stand at room temperature for 2 hours: no turbidity or deposit is produced.

(2) Acidity—Place 1.0 g of Cholesterol in a flask, dissolve in 10 mL of diethyl ether, add 10.0 mL of 0.1 mol/L sodium hydroxide VS, and shake for 1 minute. Expel the diethyl ether, and boil for 5 minutes. Cool, add 10 mL of water, and titrate <2.50> with 0.05 mol/L sulfuric acid VS (indicator: 2 drops of phenolphthalein TS). Perform a blank determination in the same manner.

The volume of 0.1 mol/L sodium hydroxide VS consumed is not more than 0.30 mL.

Loss on drying <2.41> Not more than 0.30% (1 g, in vacuum, 60°C, 4 hours).

Residue on ignition <2.44> Not more than 0.1% (1 g).

Containers and storage Containers—Tight containers.

Storage—Light-resistant.

Cibenzoline Succinate

シベンゾリンコハク酸塩

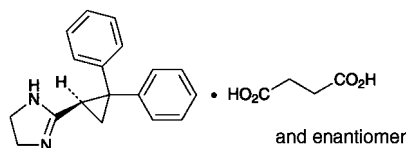

$C_{18}H_{18}N_2 \cdot C_4H_6O_4$: 380.44
 2-[(1*RS*)-2,2-Diphenylcyclopropan-1-yl]-4,5-dihydro-1*H*-imidazole monosuccinate
 [100678-32-8]

Cibenzoline Succinate, when dried, contains not less than 98.5% and not more than 101.0% of cibenzoline succinate ($C_{18}H_{18}N_2 \cdot C_4H_6O_4$).

Description Cibenzoline Succinate occurs as a white crystalline powder.

It is freely soluble in methanol and in acetic acid (100), and sparingly soluble in water and in ethanol (99.5).

A solution of Cibenzoline Succinate in methanol (1 in 10) shows no optical rotation.

Identification (1) Determine the absorption spectrum of a solution of Cibenzoline Succinate (1 in 50,000) as directed under Ultraviolet-visible Spectrophotometry <2.24>, and compare the spectrum with the Reference Spectrum: both spectra exhibit similar intensities of absorption at the same wavelengths.

(2) Determine the infrared absorption spectrum of Cibenzoline Succinate as directed in the paste method under Infrared Spectrophotometry <2.25>, and compare the spectrum with the Reference Spectrum: both spectra exhibit similar intensities of absorption at the same wave numbers.

(3) Shake 0.4 g of Cibenzoline Succinate with 2.5 mL of sodium hydroxide TS and 5 mL of ethyl acetate, allow to stand, and to 1 mL of the water layer so obtained add 0.5 mL of 1 mol/L hydrochloric acid TS and 0.5 mL of iron (III) chloride TS: a blown precipitate is formed.

Melting point <2.60> 163 – 167°C

pH <2.54> Dissolve 0.20 g of Cibenzoline Succinate in 10 mL of water: the pH of this solution is between 4.0 and 6.0.

Purity (1) Clarity and color of solution—A solution obtained by dissolving 0.20 g of Cibenzoline Succinate in 10 mL of water is clear and colorless.

(2) Heavy metals <1.07>—Proceed with 1.0 g of Cibenzoline Succinate according to Method 2, and perform the test. Prepare the control solution with 2.0 mL of Standard Lead Solution (not more than 20 ppm).

(3) Arsenic <1.11>—Prepare the test solution with 1.0 g of Cibenzoline Succinate according to Method 3, using a solution of magnesium nitrate hexahydrate in ethanol (95) (1 in 25), and perform the test (not more than 2 ppm).

(4) Related substances—Dissolve 0.10 g of Cibenzoline Succinate in 10 mL of methanol, and use this solution as the sample solution. Pipet 1 mL of the sample solution, and add methanol to make exactly 100 mL. Pipet 5 mL and 2 mL of this solution, add methanol to make them exactly 10 mL, and use these solutions as the standard solution (1) and the standard solution (2). Perform the test with these solutions as directed under Thin-layer Chromatography <2.03>. Spot 10 μ L each of the sample solution and standard solutions (1)

and (2) on a plate of silica gel with fluorescent indicator for thin-layer chromatography. Develop the plate with a mixture of ethyl acetate, methanol and ammonia solution (28) (20:3:2) to a distance of about 10 cm, air-dry the plate, and dry more at 80°C for 30 minutes. After cooling, examine under ultraviolet light (main wavelength: 254 nm): the spot other than the principal spot obtained from the sample solution is not more intense than the spot from the standard solution (1). Allow the plate to stand for 30 minutes in iodine vapor: the spot other than the principal spot from the sample solution is not more intense than the spot from the standard solution (1), and the spot, which is more intense than the spot from the standard solution (2), is not more than two.

Loss on drying <2.41> Not more than 0.3% (1 g, 105°C, 2 hours).

Residue on ignition <2.44> Not more than 0.1% (1 g).

Assay Weigh accurately about 0.4 g of Cibenzoline Succinate, previously dried, dissolve in 50 mL of acetic acid (100), and titrate <2.50> with 0.1 mol/L perchloric acid VS until the color of the solution changes from violet to blue-green through blue (indicator: 2 drops of crystal violet TS). Perform a blank determination in the same manner, and make any necessary correction.

Each mL of 0.1 mol/L perchloric acid VS
 = 38.04 mg of $C_{18}H_{18}N_2 \cdot C_4H_6O_4$

Containers and storage Containers—Tight containers.

Cibenzoline Succinate Tablets

シベンゾリンコハク酸塩錠

Cibenzoline Succinate Tablets contain not less than 95.0% and not more than 105.0% of the labeled amount of cibenzoline succinate ($C_{18}H_{18}N_2 \cdot C_4H_6O_4$: 380.44).

Method of preparation Prepare as directed under Tablets, with Cibenzoline Succinate.

Identification To a quantity of powdered Cibenzoline Succinate Tablets, equivalent to 50 mg of Cibenzoline Succinate, add 100 mL of water, shake for 10 minutes, and centrifuge. To 2 mL of the supernatant liquid add water to make 50 mL, and determine the absorption spectrum of this solution as directed under Ultraviolet-visible Spectrophotometry <2.24>: it exhibits a maximum between 221 nm and 225 nm.

Uniformity of dosage units <6.02> Perform the Mass variation test, or the Content uniformity test according to the following method: it meets the requirement.

To 1 tablet of Cibenzoline Succinate Tablets add a suitable amount of water so that each mL contains about 10 mg of cibenzoline succinate ($C_{18}H_{18}N_2 \cdot C_4H_6O_4$), and allow standing for 10 minutes while occasional shaking. To this solution add methanol so that each mL contains about 2 mg of cibenzoline succinate ($C_{18}H_{18}N_2 \cdot C_4H_6O_4$), add exactly 1 mL of the internal standard solution per 10 mg of cibenzoline succinate ($C_{18}H_{18}N_2 \cdot C_4H_6O_4$), then add methanol so that each mL contains about 1 mg of cibenzoline succinate ($C_{18}H_{18}N_2 \cdot C_4H_6O_4$). Centrifuge the solution, and use the supernatant liquid as the sample solution. Then, proceed as directed in the Assay.

Amount (mg) of cibenzoline succinate ($C_{18}H_{18}N_2 \cdot C_4H_6O_4$)
 = $M_S \times Q_T / Q_S \times C / 100$

M_S : Amount (mg) of cibenzoline succinate for assay taken
 C : Labeled amount (mg) of cibenzoline succinate
 $(C_{18}H_{18}N_2 \cdot C_4H_6O_4)$ in 1 tablet

Internal standard solution—Dissolve 0.1 g of 2-ethylhexyl parahydroxybenzoate in methanol to make 100 mL.

Dissolution <6.10> When the test is performed at 50 revolutions per minute according to the Paddle method, using 900 mL of water as the dissolution medium, the dissolution rate in 15 minutes of Cibenzoline Succinate Tablets is not less than 80%.

Start the test with 1 tablet of Cibenzoline Succinate Tablets, withdraw not less than 20 mL of the medium at the specified minute after starting the test, and filter through a membrane filter with a pore size not exceeding 0.45 μ m. Discard not less than 10 mL of the first filtrate, pipet V mL of the subsequent filtrate, add water to make exactly V' mL so that each mL contains about 11 μ g of cibenzoline succinate ($C_{18}H_{18}N_2 \cdot C_4H_6O_4$), and use this solution as the sample solution. Separately, weigh accurately about 28 mg of cibenzoline succinate for assay, previously dried at 105°C for 2 hours, and dissolve in water to make exactly 100 mL. Pipet 2 mL of this solution, add water to make exactly 50 mL, and use this solution as the standard solution. Determine the absorbances, A_T and A_S , of the sample solution and standard solution at 222 nm as directed under Ultraviolet-visible Spectrophotometry <2.24>.

Dissolution rate (%) with respect to the labeled amount of cibenzoline succinate ($C_{18}H_{18}N_2 \cdot C_4H_6O_4$)
 $= M_S \times A_T / A_S \times V' / V \times 1 / C \times 36$

M_S : Amount (mg) of cibenzoline succinate for assay taken
 C : Labeled amount (mg) of cibenzoline succinate
 $(C_{18}H_{18}N_2 \cdot C_4H_6O_4)$ in 1 tablet

Assay Weigh accurately not less than 20 Cibenzoline Succinate Tablets, and powder. Weigh accurately a portion of the powder, equivalent to about 0.1 g of cibenzoline succinate ($C_{18}H_{18}N_2 \cdot C_4H_6O_4$), add 10 mL of water, shake, and add 40 mL of methanol and exactly 10 mL of the internal standard solution. Shake for 20 minutes, add methanol to make 100 mL, centrifuge, and use the supernatant liquid as the sample solution. Separately, weigh accurately about 0.1 g of cibenzoline succinate for assay, previously dried at 105°C for 2 hours, add 10 mL of water and 40 mL of methanol to dissolve, then add exactly 10 mL of the internal standard solution and methanol to make 100 mL, and use this solution as the standard solution. Perform the test with 5 μ L each of the sample solution and standard solution as directed under Liquid Chromatography <2.01> according to the following conditions, and calculate the ratios, Q_T and Q_S , of the peak area of cibenzoline to that of the internal standard.

Amount (mg) of cibenzoline succinate ($C_{18}H_{18}N_2 \cdot C_4H_6O_4$)
 $= M_S \times Q_T / Q_S$

M_S : Amount (mg) of cibenzoline succinate for assay taken

Internal standard solution—Dissolve 0.1 g of 2-ethylhexyl parahydroxybenzoate in methanol to make 100 mL.

Operating conditions—

Detector: An ultraviolet absorption photometer (wavelength: 254 nm).

Column: A stainless steel column 4.6 mm in inside diameter and 5 cm in length, packed with octadecylsilanized silica gel for liquid chromatography (3 μ m in particle diameter).

Column temperature: A constant temperature of about 25°C.

Mobile phase: Dissolve 2.67 g of sodium di-2-ethylhexyl

sulfosuccinate in 2000 mL of a mixture of water, acetonitrile and diluted phosphoric acid (1 in 10) (1000:1000:1).

Flow rate: Adjust so that the retention time of cibenzoline is about 3 minutes.

System suitability—

System performance: When the procedure is run with 5 μ L of the standard solution under the above operating conditions, cibenzoline and the internal standard are eluted in this order with the resolution between these peaks being not less than 6.

System repeatability: When the test is repeated 6 times with 5 μ L of the standard solution under the above operating conditions, the relative standard deviation of the ratio of the peak area of cibenzoline to that of the internal standard is not more than 1.0%.

Containers and storage Containers—Tight containers.

Ciclacillin

シクラシリン

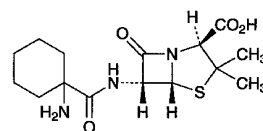

$C_{15}H_{23}N_3O_4S$: 341.43
 (2*S*,5*R*,6*R*)-6-[(1-Aminocyclohexanecarbonyl)amino]-3,3-dimethyl-7-oxo-4-thia-1-azabicyclo[3.2.0]heptane-2-carboxylic acid
 [3485-14-1]

Ciclacillin contains not less than 920 μ g (potency) and not more than 1010 μ g (potency) per mg, calculated on the anhydrous basis. The potency of Ciclacillin is expressed as mass (potency) of ciclacillin ($C_{15}H_{23}N_3O_4S$).

Description Ciclacillin occurs as white to light yellow-white crystalline powder.

It is sparingly soluble in water, slightly soluble in methanol, and practically insoluble in acetonitrile and in ethanol (99.5).

Identification Determine the infrared absorption spectrum of Ciclacillin as directed in the potassium bromide disk method under Infrared Spectrophotometry <2.25>, and compare the spectrum with the Reference Spectrum or the spectrum of Ciclacillin RS: both spectra exhibit similar intensities of absorption at the same wave numbers.

Optical rotation <2.49> $[\alpha]_D^{20}$: +300 – +315° (2 g, water, 100 mL, 100 mm).

Purity (1) Heavy metals <1.07>—Proceed with 1.0 g of Ciclacillin according to Method 2, and perform the test. Prepare the control solution with 2.0 mL of Standard Lead Solution (not more than 20 ppm).

(2) Arsenic <1.11>—Prepare the test solution with 1.0 g of Ciclacillin according to Method 3, and perform the test (not more than 2 ppm).

Water <2.48> Not more than 2.0% (1 g, volumetric titration, direct titration).

Assay Weigh accurately an amount of Ciclacillin and Ciclacillin RS, equivalent to about 50 mg (potency), dissolve each in a suitable amount of the mobile phase, add exactly 5

mL of the internal standard solution and the mobile phase to make 50 mL, and use these solutions as the sample solution and standard solution. Perform the test with 10 μ L each of the sample solution and standard solution as directed under Liquid Chromatography <2.01> according to the following conditions, and calculate the ratios, Q_T and Q_S , of the peak area of ciclacillin to that of the internal standard.

$$\begin{aligned} \text{Amount } [\mu\text{g (potency)] of ciclacillin (C}_{15}\text{H}_{23}\text{N}_3\text{O}_4\text{S)} \\ = M_S \times Q_T / Q_S \times 1000 \end{aligned}$$

M_S : Amount [mg (potency)] of Ciclacillin RS taken

Internal standard solution—A solution of orcin in the mobile phase (1 in 500).

Operating conditions—

Detector: An ultraviolet absorption photometer (wavelength: 254 nm).

Column: A stainless steel column 4 mm in inside diameter and 15 cm in length, packed with octadecylsilanized silica gel for liquid chromatography (5 μ m in particle diameter).

Column temperature: A constant temperature of about 25°C.

Mobile phase: Dissolve 0.771 g of ammonium acetate in about 900 mL of water, adjust the pH to 4.0 with acetic acid (100), and add water to make 1000 mL. To 850 mL of this solution add 150 mL of acetonitrile.

Flow rate: Adjust so that the retention time of ciclacillin is about 4 minutes.

System suitability—

System performance: When the procedure is run with 10 μ L of the standard solution under the above operating conditions, ciclacillin and the internal standard are eluted in this order with the resolution between these peaks being not less than 8.

System repeatability: When the test is repeated 6 times with 10 μ L of the standard solution under the above operating conditions, the relative standard deviation of the ratios of the peak areas of ciclacillin to that of the internal standard is not more than 1.0%.

Containers and storage Containers—Tight containers.

Ciclosporin

シクロスポリン

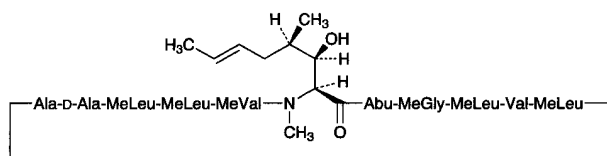

Abu = (2*S*)-2-Aminobutyric acid

MeGly = *N*-Methylglycine

MeLeu = *N*-Methylleucine

MeVal = *N*-Methylvaline

$C_{62}H_{111}N_{11}O_{12}$: 1202.61

cyclo{-[(2*S*,3*R*,4*R*,6*E*)-3-Hydroxy-4-methyl-2-methylamino-oct-6-enyl]-L-2-aminobutanoyl-*N*-methylglycyl-*N*-methyl-L-leucyl-L-valyl-*N*-methyl-L-leucyl-L-alanyl-D-alanyl-*N*-methyl-L-leucyl-*N*-methyl-L-leucyl-*N*-methyl-L-valyl-}

[59865-13-3]

Ciclosporin contains not less than 98.5% and not more than 101.5% of ciclosporin ($C_{62}H_{111}N_{11}O_{12}$), cal-

culated on the dried basis.

Description Ciclosporin occurs as a white powder.

It is very soluble in acetonitrile, in methanol and in ethanol (95), freely soluble in diethyl ether, and practically insoluble in water.

Identification Determine the infrared absorption spectrum of Ciclosporin as directed in the potassium bromide disk method under Infrared Spectrophotometry <2.25>, and compare the spectrum with the Reference Spectrum or the spectrum of Ciclosporin RS: both spectra exhibit similar intensities of absorption at the same wave numbers.

Optical rotation <2.49> $[\alpha]_D^{20}$: -185 – -193° (0.1 g calculated on the dried basis, methanol, 20 mL, 100 mm).

Purity (1) Clarity and color of solution—Dissolve 1.0 g of Ciclosporin in 10 mL of ethanol (95): the solution is clear, and has no more color than the following control solutions (1), (2) or (3).

Control solution (1): To exactly 3.0 mL of Iron (III) Chloride CS and exactly 0.8 mL of Cobalt (II) Chloride CS add diluted hydrochloric acid (1 in 40) to make exactly 100 mL.

Control solution (2): To exactly 3.0 mL of Iron (III) Chloride CS, exactly 1.3 mL of Cobalt (II) Chloride CS and exactly 0.5 mL of Copper (II) Sulfate CS add diluted hydrochloric acid (1 in 40) to make exactly 100 mL.

Control solution (3): To exactly 0.5 mL of Iron (III) Chloride CS and exactly 1.0 mL of Cobalt (II) Chloride CS add diluted hydrochloric acid (1 in 40) to make exactly 100 mL.

(2) Heavy metals <1.07>—Proceed with 1.0 g of Ciclosporin according to Method 2, and perform the test. Prepare the control solution with 2.0 mL of Standard Lead Solution (not more than 20 ppm).

(3) Related substances—Use the sample solution obtained in the Assay as the sample solution. Pipet 2 mL of the sample solution, add a mixture of water and acetonitrile (1:1) to make exactly 200 mL, and use this solution as the standard solution. Perform the test with exactly 20 μ L each of the sample solution and standard solution as directed under Liquid Chromatography <2.01> according to the following conditions. Determine each peak area of both solutions by the automatic integration method: the area of the peak other than the ciclosporin obtained from the sample solution is not larger than 7/10 times the peak area of ciclosporin from the standard solution, and the total area of all peaks other than the ciclosporin from the sample solution is not larger than 1.5 times the peak area of ciclosporin from the standard solution.

Operating conditions—

Detector, column, column temperature, mobile phase, and flow rate: Proceed as directed in the operating conditions in the Assay.

Time span of measurement: About 2 times as long as the retention time of ciclosporin, beginning after the solvent peak.

System suitability—

System performance: Proceed as directed in the system suitability in the Assay.

Test for required detectability: To exactly 2 mL of the standard solution add a mixture of water and acetonitrile (1:1) to make exactly 20 mL. Confirm that the peak area of ciclosporin obtained from 20 μ L of this solution is equivalent to 7 to 13% of that of ciclosporin obtained from 20 μ L of the standard solution.

System repeatability: When the test is repeated 6 times with 20 μ L of the standard solution under the above operating conditions, the relative standard deviation of the peak

area of ciclosporin is not more than 3.0%.

Loss on drying <2.41> Not more than 2.0% (1 g, in vacuum at a pressure not exceeding 0.67 kPa, 60°C, 3 hours).

Residue on ignition <2.44> Not more than 0.1% (0.5 g).

Assay Weigh accurately about 30 mg each of Ciclosporin and Ciclosporin RS (separately determine the loss on drying <2.41> under the same conditions as Ciclosporin), and dissolve each in a mixture of water and acetonitrile (1:1) to make exactly 25 mL, and use these solutions as the sample solution and standard solution. Perform the test with exactly 20 μ L each of the sample solution and standard solution as directed under Liquid Chromatography <2.01> according to the following conditions, and determine the peak areas, A_T and A_S , of ciclosporin in each solution.

$$\begin{aligned} & \text{Amount (mg) of ciclosporin (C}_{62}\text{H}_{111}\text{N}_{11}\text{O}_{12}) \\ & = M_S \times A_T / A_S \end{aligned}$$

M_S : Amount (mg) of Ciclosporin RS taken, calculated on the dried basis

Operating conditions—

Detector: An ultraviolet absorption photometer (wavelength: 210 nm).

Column: A stainless steel column 4 mm in inside diameter and 25 cm in length, packed with octadecylsilanized silica gel for liquid chromatography (5 μ m in particle diameter). Connect the sample injection port and the column with a stainless steel tube 0.3 mm in inside diameter and 1 m in length.

Column temperature: A constant temperature of about 80°C (including the sample injection port and the connecting tube).

Mobile phase: A mixture of water, acetonitrile, tert-butyl methyl ether and phosphoric acid (520:430:50:1).

Flow rate: Adjust so that the retention time of ciclosporin is about 27 minutes.

System suitability—

System performance: Dissolve 3 mg of Ciclosporin U in 2.5 mL of a mixture of water and acetonitrile (1:1), and add 2.5 mL of the standard solution. When the procedure is run with 20 μ L of this solution under the above operating conditions, ciclosporin U and ciclosporin are eluted in this order with the resolution between these peaks being not less than 1.2.

System repeatability: When the test is repeated 6 times with 20 μ L of the standard solution under the above operating conditions, the relative standard deviation of the peak area of ciclosporin is not more than 1.0%.

Containers and storage Containers—Tight containers.

Storage—Light-resistant.

Cilastatin Sodium

シラスタチンナトリウム

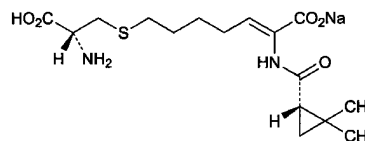

$\text{C}_{16}\text{H}_{25}\text{N}_2\text{NaO}_5\text{S}$: 380.43

Monosodium (2Z)-7-[[{(2R)-2-amino-2-carboxyethyl]sulfanyl]-2-[[{(1S)-2,2-dimethylcyclopropyl]carbonyl]amino]hept-2-enoate [81129-83-1]

Cilastatin Sodium contains not less than 98.0% and not more than 101.0% of cilastatin sodium ($\text{C}_{16}\text{H}_{25}\text{N}_2\text{NaO}_5\text{S}$), calculated on the anhydrous and residual solvent-free basis.

Description Cilastatin Sodium occurs as a white to pale yellowish white powder.

It is very soluble in water, freely soluble in methanol, and slightly soluble in ethanol (99.5).

It is hygroscopic.

Identification (1) Determine the infrared absorption spectrum of Cilastatin Sodium as directed in the potassium bromide disk method under Infrared Spectrophotometry <2.25>, and compare the spectrum with the Reference Spectrum: both spectra exhibit similar intensities of absorption at the same wave numbers.

(2) A solution of Cilastatin Sodium (1 in 10) responds to Qualitative Tests <1.09> for sodium salt.

Optical rotation <2.49> $[\alpha]_D^{20}$: +41.5 – +44.5° (0.1 g calculated on the anhydrous and residual solvent-free basis, a solution of hydrochloric acid in methanol (9 in 1000), 10 mL, 100 mL).

pH <2.54> The pH of a solution prepared by dissolving 1.0 g of Cilastatin Sodium in 100 mL of water is between 6.5 and 7.5.

Purity (1) Clarity and color of solution—Dissolve 1.0 g of Cilastatin Sodium in 100 mL of water: the solution is clear and the solution has no more color than the following control solution.

Control solution: To a mixture of 2.4 mL of Iron (III) Chloride CS and 0.6 mL of Cobalt (II) Chloride CS add water to make 10 mL, pipet 5 mL of this solution, and add water to make exactly 100 mL.

(2) Heavy metals <1.07>—Proceed with 1.0 g of Cilastatin Sodium according to Method 2, and perform the test. After carbonization, add 0.5 mL of sulfuric acid instead of nitric acid. Prepare the control solution with 2.0 mL of Standard Lead Solution (not more than 20 ppm).

(3) Arsenic <1.11>—To 2.0 g of Cilastatin Sodium add 5 mL of nitric acid and 1 mL of sulfuric acid, and heat carefully until white fumes are evolved. After cooling, heat with two 2-mL portions of nitric acid, then heat with several 2-mL portions of hydrogen peroxide (30) until a colorless or pale yellow solution is obtained. After cooling, heat again until white fumes are evolved. After cooling, add water to make 5 mL, and perform the test with this solution as the test solution: it shows no more color than the following color standard.

Color standard: Prepare a solution according to the above

procedure without using Cilastatin Sodium, add exactly 2 mL of Standard Arsenic Solution, and perform the test in the same manner as the test solution (not more than 1 ppm).

(4) Related substances—Dissolve about 40 mg of Cilastatin Sodium in 25 mL of water, and use this solution as the sample solution. Pipet 3 mL of the sample solution, add water to make exactly 100 mL, and use this solution as the standard solution. Perform the test with exactly 20 μ L each of the sample solution and standard solution as directed under Liquid Chromatography <2.01> according to the following conditions, and determine each peak area by the automatic integration method: the area of the peak other than cilastatin obtained from the sample solution is not larger than 1/6 times the peak area of cilastatin from the standard solution, and the total area of the peaks other than the peak of cilastatin from the sample solution is not larger than the peak area of cilastatin from the standard solution.

Operating conditions—

Detector: An ultraviolet absorption photometer (wavelength: 210 nm).

Column: A stainless steel column 4.5 mm in inside diameter and 25 cm in length, packed with octadecylsilanized silica gel for liquid chromatography (5 μ m in particle diameter).

Column temperature: A constant temperature of about 50°C.

Mobile phase A: A mixture of diluted phosphoric acid (1 in 1000) and acetonitrile (7:3).

Mobile phase B: Diluted phosphoric acid (1 in 1000).

Flowing of mobile phase: Control the gradient by mixing the mobile phases A and B as directed in the following table.

Time after injection of sample (min)	Mobile phase A (vol%)	Mobile phase B (vol%)
0 – 30	15 → 100	85 → 0
30 – 40	100	0

Flow rate: 2.0 mL per minute.

Time span of measurement: For 40 minutes.

System suitability—

Test for required detectability: Pipet 1 mL of the standard solution, and add water to make exactly 30 mL. Confirm that the peak area of cilastatin obtained with 20 μ L of this solution is equivalent to 2.3 to 4.5% of that with 20 μ L of the standard solution.

System performance: When the procedure is run with 20 μ L of the standard solution under the above operating conditions, the retention time of cilastatin is about 20 minutes, and the number of theoretical plates and the symmetry factor of the peak of cilastatin are not less than 10,000 and not more than 2.5, respectively.

System repeatability: When the test is repeated 3 times with 20 μ L of the standard solution under the above operating conditions, the relative standard deviation of the peak area of cilastatin is not more than 2.0%.

(5) Residual solvents <2.46>—Weigh accurately about 0.2 g of Cilastatin Sodium, add exactly 2 mL of the internal standard solution, dissolve in water to make 10 mL, and use this solution as the sample solution. Separately, measure exactly 2 mL of acetone, 0.5 mL of methanol and 0.5 mL of mesityl oxide, and add water to make exactly 1000 mL. Pipet 2 mL of this solution, add exactly 2 mL of the internal standard solution, add water to make 10 mL, and use this solution as the standard solution. Perform the test with 2 μ L each of the sample solution and standard solution as directed under Gas Chromatography <2.02> according to the following con-

ditions. Calculate the ratios of the peak areas of acetone, methanol and mesityl oxide and to the peak area of the internal standard, Q_{Ta} and Q_{Sa} , Q_{Tb} and Q_{Sb} , Q_{Tc} and Q_{Sc} , and calculate the amounts of acetone, methanol and mesityl oxide by the following equation: they are not more than 1.0%, not more 0.5% and not more than 0.4%, respectively.

$$\begin{aligned} \text{Amount (\%)} \text{ of acetone (CH}_3\text{COCH}_3) \\ = 1/M_T \times Q_{Ta}/Q_{Sa} \times 400 \times 0.79 \end{aligned}$$

$$\begin{aligned} \text{Amount (\%)} \text{ of methanol (CH}_3\text{OH)} \\ = 1/M_T \times Q_{Tb}/Q_{Sb} \times 100 \times 0.79 \end{aligned}$$

$$\begin{aligned} \text{Amount (\%)} \text{ of mesityl oxide (CH}_3\text{COCH} = \text{C(CH}_3)_2) \\ = 1/M_T \times Q_{Tc}/Q_{Sc} \times 100 \times 0.86 \end{aligned}$$

M_T : Amount (mg) of Cilastatin Sodium taken

0.79: Density (g/mL) of acetone and methanol

0.86: Density (g/mL) of mesityl oxide

*Internal standard solution—*To 0.5 mL of 1-propanol add water to make 1000 mL.

Operating conditions—

Detector: A hydrogen flame-ionization detector.

Column: A glass column 3.2 mm in inside diameter and 2.1 m in length, packed with tetrafluoroethylene polymer for gas chromatography (250 – 420 μ m) coated with polyethylene glycol 20 M for gas chromatography at the ratio of 10%.

Column temperature: A constant temperature of about 70°C.

Carrier gas: Helium.

Flow rate: Adjust so that the retention time of the internal standard is about 5 minutes.

Time span of measurement: About 3 times as long as the retention time of the internal standard.

System suitability—

System performance: When the procedure is run with 2 μ L of the standard solution under the above operating conditions, acetone, methanol, 1-propanol and mesityl oxide are eluted in this order, and these peaks completely separate each other.

System repeatability: When the test is repeated 6 times with 2 μ L of the standard solution under the above operating conditions, the relative standard deviations of the ratio of the peak area of acetone, methanol and mesityl oxide to that of the internal standard are not more than 4.0%, respectively.

Water <2.48> Not more than 2.0% (0.5 g, volumetric titration, direct titration).

Assay Weigh accurately about 0.3 g of Cilastatin Sodium, dissolve in 30 mL of methanol, add 5 mL of water, and adjust to pH 3.0 with 0.1 mol/L hydrochloric acid TS. Titrate <2.50> with 0.1 mol/L sodium hydroxide VS from the first equivalence point to the third equivalence point (potentiometric titration), and make any necessary correction.

$$\begin{aligned} \text{Each mL of 0.1 mol/L sodium hydroxide VS} \\ = 19.02 \text{ mg of C}_{16}\text{H}_{25}\text{N}_2\text{NaO}_5\text{S} \end{aligned}$$

Containers and storage Containers—Tight containers.

Storage—In a cold place.

Cilazapril Hydrate

シラザプリル水和物

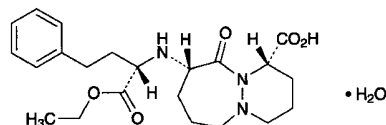

$C_{22}H_{31}N_3O_5 \cdot H_2O$: 435.51
 (1*S*,9*S*)-9-[(1*S*)-(1-Ethoxycarbonyl-3-phenylpropyl)amino]-10-oxooctahydro-6*H*-pyridazino[1,2-*a*][1,2]diazepine-1-carboxylic acid monohydrate
 [92077-78-6]

Cilazapril Hydrate contains not less than 98.5% and not more than 101.0% of cilazapril ($C_{22}H_{31}N_3O_5$: 417.50), calculated on the anhydrous basis.

Description Cilazapril Hydrate occurs as white to yellowish white, crystals or crystalline powder.

It is very soluble in methanol, freely soluble in ethanol (99.5) and in acetic acid (100), and slightly soluble in water.

It gradually turns yellow on exposure to light.

Melting point: about 101°C (with decomposition).

Identification (1) To 4 mL of a solution of Cilazapril Hydrate (1 in 1000) add 2 mL of Dragendorff's TS: an orange precipitate is produced.

(2) Determine the infrared absorption spectrum of Cilazapril Hydrate as directed in the potassium bromide disk method under Infrared Spectrophotometry <2.25>, and compare the spectrum with the Reference Spectrum: both spectra exhibit similar intensities of absorption at the same wave numbers.

Optical rotation <2.49> $[\alpha]_D^{20}$: $-53 - -58^\circ$ (0.2 g calculated on the anhydrous basis, methanol, 20 mL, 100 mm).

Purity (1) Chloride <1.03>—Perform the test using 1.0 g of Cilazapril Hydrate. Prepare the control solution with 0.25 mL of 0.01 mol/L hydrochloric acid VS (not more than 0.009%).

(2) **Sulfate** <1.14>—Dissolve 1.0 g of Cilazapril Hydrate in 40 mL of water and 1.5 mL of dilute hydrochloric acid, and add water to make 50 mL. Perform the test using this solution as the test solution. Prepare the control solution with 0.40 mL of 0.005 mol/L sulfuric acid VS (not more than 0.019%).

(3) **Heavy metals** <1.07>—Proceed with 1.0 g of Cilazapril Hydrate according to Method 4, and perform the test. However, use 10 mL of a solution of magnesium nitrate hexahydrate in ethanol (95) (1 in 8). Prepare the control solution with 2.0 mL of Standard Lead Solution (not more than 20 ppm).

(4) **Related substances**—Dissolve 0.10 g of Cilazapril Hydrate in 20 mL of methanol, and use this solution as the sample solution. Pipet 1 mL of the sample solution, add methanol to make exactly 100 mL, and use this solution as the standard solution (1). Pipet 3 mL of the standard solution (1), add methanol to make exactly 10 mL, and use this solution as the standard solution (2). Separately, pipet 2 mL of the standard solution (1), add methanol to make exactly 10 mL, and use this solution as the standard solution (3). Perform the test with these solutions as directed under Thin-layer Chromatography <2.03>. Spot 20 μ L each of the sample solution and three standard solutions on a plate of silica gel

with fluorescent indicator for thin-layer chromatography. Develop the plate with a mixture of ethyl acetate, methanol, acetic acid (100), hexane, and water (62:15:10:10:3) to a distance of about 15 cm, and air-dry the plate. Leave the plate in iodine vapor for 2 hours, and examine the plate under ultraviolet light (main wavelength: 254 nm): of the spots other than the principal spot with an R_f value close to 0.40 obtained from the sample solution, the spot in the vicinity of R_f value 0.17 is not more intense than the spot from the standard solution (1), and the spot in the vicinity of R_f value 0.44 is not more intense than the spot from the standard solution (2). The number of all other spot does not exceed 3, and of these spots, no more than one is more intense than the spot from the standard solution (3) and none are more intense than the spot from the standard solution (2).

Water <2.48> 3.5 – 5.0% (0.3 g, volumetric titration, direct titration).

Residue on ignition <2.44> Not more than 0.1% (0.5 g).

Assay Weigh accurately about 0.2 g of Cilazapril Hydrate, dissolve in 50 mL of acetic acid (100), and titrate <2.50> with 0.02 mol/L perchloric acid VS (potentiometric titration). Perform a blank determination in the same manner, and make any necessary correction.

Each mL of 0.02 mol/L perchloric acid VS
 = 8.350 mg of $C_{22}H_{31}N_3O_5$

Containers and storage Containers—Tight containers.
 Storage—Light-resistant.

Cilazapril Tablets

シラザプリル錠

Cilazapril Tablets contain not less than 93.0% and not more than 107.0% of the labeled amount of cilazapril ($C_{22}H_{31}N_3O_5$: 417.50).

Method of preparation Prepare as directed under Tablets, with Cilazapril Hydrate.

Identification To a quantity of powdered Cilazapril Tablets, equivalent to 2 mg of cilazapril ($C_{22}H_{31}N_3O_5$), add 2 mL of a mixture of acetonitrile and ethyl acetate (3:1), shake, sonicate for 30 seconds, centrifuge, and use the supernatant liquid as the sample solution. Separately, dissolve 5 mg of cilazapril in 5 mL of the mixture of acetonitrile and ethyl acetate (3:1), and use this solution as the standard solution. Perform the test with these solutions as directed under Thin-layer Chromatography <2.03>. Spot 20 μ L each of the sample solution and standard solution on a plate of silica gel with fluorescent indicator for thin-layer chromatography. Develop the plate with a mixture of ethyl acetate, methanol, acetic acid (100), hexane and water (62:15:10:10:3) to a distance of about 15 cm, and air-dry the plate. Place the plate in iodine vapor for 2 hours, and immediately examine under ultraviolet light (main wavelength: 254 nm): the spots obtained from the sample and standard solutions are dark brown and they show the same R_f value.

Uniformity of dosage units <6.02> Perform the test according to the following method: it meets the requirement of the Content uniformity test.

To 1 tablet of Cilazapril Tablets add 5 mL of a mixture of water and acetonitrile (7:3), shake well until disintegration, add the mixture of water and acetonitrile (7:3) to make

exactly V mL so that each mL contains about $25 \mu\text{g}$ of cilazapril ($\text{C}_{22}\text{H}_{31}\text{N}_3\text{O}_5$), and centrifuge. Pipet 4 mL of the supernatant liquid, add exactly 1 mL of the internal standard solution, add the mixture of water and acetonitrile (7:3) to make 10 mL, and use this solution as the sample solution. Separately, weigh accurately about 26 mg of cilazapril for assay (separately determine the water <2.48> in the same manner as Cilazapril Hydrate), and dissolve in the mixture of water and acetonitrile (7:3) to make exactly 50 mL. Pipet 2 mL of this solution, add exactly 10 mL of the internal standard solution, add the mixture of water and acetonitrile (7:3) to make 100 mL, and use this solution as the standard solution. Perform the test with $100 \mu\text{L}$ each of the sample solution and standard solution as directed under Liquid Chromatography <2.01> according to the following conditions, and calculate the ratios, Q_T and Q_S , of the peak area of cilazapril to that of the internal standard.

$$\begin{aligned} &\text{Amount (mg) of cilazapril (C}_{22}\text{H}_{31}\text{N}_3\text{O}_5) \\ &= M_S \times Q_T / Q_S \times V / 1000 \end{aligned}$$

M_S : Amount (mg) of cilazapril for assay taken, calculated on the anhydrous basis

Internal standard solution—A solution of dimethyl phthalate in a mixture of water and acetonitrile (7:3) (1 in 12,500).

Operating conditions—

Proceed as directed in the operating conditions in the Assay.

System suitability—

System performance: When the procedure is run with $100 \mu\text{L}$ of the standard solution under the above conditions, cilazapril and the internal standard are eluted in this order with the resolution between these peaks being not less than 6.

System repeatability: When the test is repeated 6 times with $100 \mu\text{L}$ of the standard solution under the above conditions, the relative standard deviation of the ratio of the peak area of cilazapril to that of the internal standard is not more than 2.0%.

Dissolution <6.10> When the test is performed at 50 revolutions per minute according to the Paddle method, using 900 mL of water as the dissolution medium, the dissolution rate in 15 minutes of Cilazapril Tablets is not less than 85%.

Start the test with 1 tablet of Cilazapril Tablets, withdraw not less than 20 mL of the medium at the specified minute after starting the test, and filter through a membrane filter with a pore size not exceeding $0.45 \mu\text{m}$. Discard not less than 10 mL of the first filtrate, pipet V mL of the subsequent filtrate, and add water to make exactly V' mL so that each mL contains about $0.28 \mu\text{g}$ of cilazapril ($\text{C}_{22}\text{H}_{31}\text{N}_3\text{O}_5$). Pipet 10 mL of the solution, add exactly 5 mL of acetonitrile, and use this solution as the sample solution. Separately, weigh accurately about 29 mg of cilazapril for assay (separately determine the water <2.48> in the same manner as Cilazapril Hydrate), and dissolve in water to make exactly 100 mL. Pipet 5 mL of the solution, add water to make exactly 100 mL. Then, pipet 2 mL of this solution, add water to make exactly 100 mL. Pipet 10 mL of this solution, add exactly 5 mL of acetonitrile, and use this solution as the standard solution. Perform the test with exactly $100 \mu\text{L}$ each of the sample solution and standard solution as directed under Liquid Chromatography <2.01> according to the following conditions, and determine the peak areas, A_T and A_S , of cilazapril in each solution.

Dissolution rate (%) with respect to the labeled amount of cilazapril ($\text{C}_{22}\text{H}_{31}\text{N}_3\text{O}_5$)

$$= M_S \times A_T / A_S \times V' / V \times 1 / C \times 9 / 10$$

M_S : Amount (mg) of cilazapril for assay taken, calculated on the anhydrous basis

C : Labeled amount (mg) of cilazapril ($\text{C}_{22}\text{H}_{31}\text{N}_3\text{O}_5$) in 1 tablet

Operating conditions—

Detector: An ultraviolet absorption photometer (wavelength: 210 nm).

Column: A stainless steel column 4.6 mm in inside diameter and 15 cm in length, packed with octadecylsilanized silica gel for liquid chromatography ($5 \mu\text{m}$ in particle diameter).

Column temperature: A constant temperature of about 25°C .

Mobile phase: To a solution consisting of 180 mL of tetrahydrofuran for liquid chromatography, 120 mL of acetonitrile for liquid chromatography and 3 mL of triethylamine add water to make 1000 mL, and adjust the pH to 2.5 with phosphoric acid.

Flow rate: Adjust so that the retention time of cilazapril is about 10 minutes.

System suitability—

System performance: When the procedure is run with $100 \mu\text{L}$ of the standard solution under the above operating conditions, the number of theoretical plates and the symmetry factor of the peak of cilazapril are not less than 3000 and not more than 2.0, respectively.

System repeatability: When the test is repeated 6 times with $100 \mu\text{L}$ of the standard solution under the above operating conditions, the relative standard deviation of the peak area of cilazapril is not more than 2.0%.

Assay Weigh accurately the mass of not less than 20 Cilazapril Tablets, and powder. Weigh accurately a portion of the powder, equivalent to about 1 mg of cilazapril ($\text{C}_{22}\text{H}_{31}\text{N}_3\text{O}_5$), add 30 mL of a mixture of water and acetonitrile (7:3), and sonicate for 5 minutes. Next, add exactly 5 mL of the internal standard solution, add the mixture of water and acetonitrile (7:3) to make 50 mL, and centrifuge. Filter the supernatant liquid through a membrane filter with a pore size not exceeding $0.5 \mu\text{m}$, and use the filtrate as the sample solution. Separately, weigh accurately about 26 mg of cilazapril for assay (separately determine the water <2.48> in the same manner as Cilazapril Hydrate), and dissolve in the mixture of water and acetonitrile (7:3) to make exactly 50 mL. Pipet 2 mL of this solution, add exactly 5 mL of the internal standard solution, add the mixture of water and acetonitrile (7:3) to make 50 mL, and use this solution as the standard solution. Perform the test with $50 \mu\text{L}$ each of the sample solution and standard solution as directed under Liquid Chromatography <2.01> according to the following conditions, and calculate the ratios, Q_T and Q_S , of the peak area of cilazapril to that of the internal standard.

$$\begin{aligned} &\text{Amount (mg) of cilazapril (C}_{22}\text{H}_{31}\text{N}_3\text{O}_5) \\ &= M_S \times Q_T / Q_S \times 1 / 25 \end{aligned}$$

M_S : Amount (mg) of cilazapril for assay taken, calculated on the anhydrous basis

Internal standard solution—A solution of dimethyl phthalate in a mixture of water and acetonitrile (7:3) (1 in 12,500).

Operating conditions—

Detector: An ultraviolet absorption photometer (wavelength: 210 nm).

Column: A stainless steel column 6 mm in inside diameter and 15 cm in length, packed with octadecylsilanized silica gel for liquid chromatography ($5 \mu\text{m}$ in particle diameter).

Column temperature: A constant temperature of about 23°C .

Mobile phase: To a solution consisting of 180 mL of tetrahydrofuran for liquid chromatography, 120 mL of acetonitrile for liquid chromatography and 3 mL of triethylamine add water to make 1000 mL, and adjust the pH to 2.5 with phosphoric acid.

Flow rate: Adjust so that the retention time of cilazapril is about 10 minutes.

System suitability—

System performance: When the procedure is run with 50 μ L of the standard solution under the above operating conditions, cilazapril and the internal standard are eluted in this order with the resolution between these peaks being not less than 6.

System repeatability: When the test is repeated 6 times with 50 μ L of the standard solution under the above operating conditions, the relative standard deviation of the ratio of the peak area of cilazapril to that of the internal standard is not more than 1.0%.

Containers and storage Containers—Tight containers.

Cilnidipine

シルニジピン

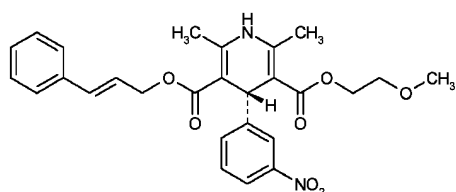

and enantiomer

$C_{27}H_{28}N_2O_7$; 492.52

3-(2-Methoxyethyl) 5-[(2E)-3-phenylprop-2-en-1-yl] (4RS)-2,6-dimethyl-4-(3-nitrophenyl)-1,4-dihydropyridine-3,5-dicarboxylate
[132203-70-4]

Cilnidipine, when dried, contains not less than 98.0% and not more than 102.0% of cilnidipine ($C_{27}H_{28}N_2O_7$).

Description Cilnidipine occurs as a faint yellow crystalline powder.

It is freely soluble in acetonitrile, sparingly soluble in methanol and in ethanol (99.5), and practically insoluble in water.

A solution of Cilnidipine in acetonitrile (1 in 100) shows no optical rotation.

It is gradually colored to reddish yellow and decomposed by light.

Identification (1) Determine the absorption spectrum of a solution of Cilnidipine in methanol (1 in 100,000) as directed under Ultraviolet-visible Spectrophotometry <2.24>, and compare the spectrum with the Reference Spectrum or the spectrum of a solution of Cilnidipine RS prepared in the same manner as the sample solution: both spectra exhibit similar intensities of absorption at the same wavelengths.

(2) Determine the infrared absorption spectrum of previously dried Cilnidipine as directed in the potassium bromide disk method under Infrared Spectrophotometry <2.25>, and compare the spectrum with the Reference Spectrum or the spectrum of dried Cilnidipine RS: both spectra exhibit similar intensities of absorption at the same wave numbers.

Melting point <2.60> 107 – 112°C

Purity (1) Heavy metals <1.07>—Proceed with 2.0 g of Cilnidipine according to Method 4, and perform the test. Prepare the control solution with 2.0 mL of Standard Lead Solution (not more than 10 ppm).

(2) Related substances—Conduct this procedure using light-resistant vessels. Dissolve 50 mg of Cilnidipine in 20 mL of acetonitrile, add the mobile phase to make 100 mL, and use this solution as the sample solution. Pipet 1 mL of the sample solution, add the mobile phase to make exactly 200 mL, and use this solution as the standard solution. Perform the test with exactly 10 μ L each of the sample solution and standard solution as directed under Liquid Chromatography <2.01> according to the following conditions, and determine each peak area by the automatic integration method: the area of the peak, having the relative retention time of about 0.5 to cilnidipine, obtained from the sample solution is not larger than 2/5 times the peak area of cilnidipine from the standard solution, the area of the peaks other than cilnidipine and the above mentioned peak from the sample solution is not larger than 1/5 times the peak area of cilnidipine from the standard solution, and the total area of the peaks other than cilnidipine from the sample solution is not larger than the peak area of cilnidipine from the standard solution. For the area of the peak, having the relative retention time of about 1.15, about 1.6, and about 1.7 to cilnidipine, multiply the correction factor, 1.5, 1.4, and 1.6, respectively.

Operating conditions—

Detector, column, column temperature, mobile phase, and flow rate: Proceed as directed in the operating conditions in the Assay.

Time span of measurement: About 3 times as long as the retention time of cilnidipine, beginning after the solvent peak.

System suitability—

System performance: Proceed as directed in the system suitability in the Assay.

Test for required detectability: Pipet 5 mL of the standard solution, add the mobile phase to make exactly 50 mL. Confirm that the peak area of cilnidipine obtained with 10 μ L of this solution is equivalent to 7 to 13% of that with 10 μ L of the standard solution.

System repeatability: When the test is repeated 6 times with 10 μ L of the standard solution under the above operating conditions, the relative standard deviation of the peak area of cilnidipine is not more than 2.0%.

Loss on drying <2.41> Not more than 0.5% (1.0 g, in vacuum, 60°C, 3 hours).

Residue on ignition <2.44> Not more than 0.1% (1 g).

Assay Conduct this procedure using light-resistant vessels. Weigh accurately about 50 mg each of Cilnidipine and Cilnidipine RS, both previously dried, dissolve in 20 mL of acetonitrile, and add the mobile phase to make exactly 100 mL, respectively. Pipet 5 mL each of these solutions, add exactly 5 mL of the internal standard solution, add the mobile phase to make 25 mL, and use these solutions as the sample solution and the standard solution, respectively. Perform the test with 10 μ L each of the sample solution and standard solution as directed under Liquid Chromatography <2.01> according to the following conditions, and calculate the ratios, Q_T and Q_S , of the peak area of cilnidipine to that of the internal standard.

Amount (mg) of cilnidipine ($C_{27}H_{28}N_2O_7$) = $M_S \times Q_T/Q_S$

M_S : Amount (mg) of Cilnidipine RS taken

Internal standard solution—A solution of butyl parahy-

droxybenzoate in acetonitrile (1 in 1000).

Operating conditions—

Detector: An ultraviolet absorption photometer (wavelength: 240 nm).

Column: A stainless steel column 4.6 mm in inside diameter and 25 cm in length, packed with perfluorohexylpropylsilylated silica gel for liquid chromatography (5 μm in particle diameter).

Column temperature: A constant temperature of about 25°C.

Mobile phase: Dissolve 1.36 g of sodium acetate trihydrate in water to make 1000 mL, and adjust to pH 5.5 with diluted acetic acid (100) (1 in 100). To 400 mL of this solution add 600 mL of methanol.

Flow rate: Adjust so that the retention time of cilnidipine is about 20 minutes.

System suitability—

System performance: After exposing Cilnidipine to a fluorescent light (15,000 lx·h), take 10 mg, dissolve in 4 mL of acetonitrile, and add the mobile phase to make 20 mL. When the procedure is run with 10 μL of this solution under the above operating conditions, the resolution between the peak of cilnidipine and the peak having the relative retention time of about 1.07 to cilnidipine is not less than 1.5.

System repeatability: When the test is repeated 6 times with 10 μL of the standard solution under the above operating conditions, the relative standard deviation of the ratio of the peak area of cilnidipine to that of the internal standard is not more than 1.0%.

Containers and storage Containers—Tight containers. Storage—Light-resistant.

Cilnidipine Tablets

シルニジピン錠

Cilnidipine Tablets contain not less than 95.0% and not more than 105.0% of the labeled amount of cilnidipine ($\text{C}_{27}\text{H}_{28}\text{N}_2\text{O}_7$; 492.52).

Method of preparation Prepare as directed under Tablets, with Cilnidipine.

Identification Powder Cilnidipine Tablets. To a portion of the powder, equivalent to 20 mg of Cilnidipine, add 20 mL of methanol, shake well, and centrifuge. To 1 mL of the supernatant liquid add methanol to make 100 mL. Determine the absorption spectrum of this solution as directed under Ultraviolet-visible Spectrophotometry <2.24>: it exhibits maxima between 238 nm and 242 nm and between 350 nm and 360 nm.

Purity Related substances—Conduct this procedure using light-resistant vessels. Powder Cilnidipine Tablets. To a portion of the powder, equivalent to 25 mg of Cilnidipine, add 40 mL of the mobile phase, shake well, and add the mobile phase to make 50 mL. Centrifuge, and use the supernatant liquid as the sample solution. Pipet 3 mL of the sample solution, add the mobile phase to make exactly 200 mL, and use this solution as the standard solution. Perform the test with exactly 20 μL each of the sample solution and standard solution as directed under Liquid Chromatography <2.01> according to the following conditions, and determine each peak area by the automatic integration method: the area of the peak, having the relative retention time of about 1.09 to cilnidipine, obtained from the sample solution is not larger

than 1/3 times the peak area of cilnidipine from the standard solution, the area of the peaks other than cilnidipine and the peak mentioned above from the sample solution is not larger than 2/15 times the peak area of cilnidipine from the standard solution, and the total area of the peaks other than cilnidipine from the sample solution is not larger than the peak area of cilnidipine from the standard solution. For the area of the peak, having the relative retention time of about 1.09 to cilnidipine, multiply the correction factor, 1.4.

Operating conditions—

Detector, column, column temperature, mobile phase, and flow rate: Proceed as directed in the operating conditions in the Assay.

Time span of measurement: About 2 times as long as the retention time of cilnidipine, beginning after the solvent peak.

System suitability—

Test for required detectability: Pipet 5 mL of the standard solution, add the mobile phase to make exactly 150 mL. Confirm that the peak area of cilnidipine obtained with 20 μL of this solution is equivalent to 2.4 to 4.3% of that with 20 μL of the standard solution.

System performance: When the procedure is run with 20 μL of standard solution under the above operating conditions, the number of theoretical plates and the symmetry factor of the peak of cilnidipine are not less than 15,000 and not more than 1.5, respectively.

System repeatability: When the test is repeated 6 times with 20 μL of the standard solution under the above operating conditions, the relative standard deviation of the peak area of cilnidipine is not more than 2.0%.

Uniformity of dosage units <6.02> Perform the test according to the following method: it meets the requirement of the Content uniformity test.

Conduct this procedure using light-resistant vessels. To 1 tablet of Cilnidipine Tablets add $V/10$ mL of water, and shake to completely disintegrate the tablet. Add acetonitrile to make exactly V mL so that each mL contains about 0.2 mg of cilnidipine ($\text{C}_{27}\text{H}_{28}\text{N}_2\text{O}_7$), and centrifuge. Pipet 4 mL of the supernatant liquid, add a mixture of acetonitrile and water (9:1) to make exactly 20 mL, filter, if necessary, and use this solution as the sample solution. Separately, weigh accurately about 20 mg of Cilnidipine RS, previously dried in vacuum at 60°C for 3 hours, dissolve in a mixture of acetonitrile and water (9:1) to make exactly 50 mL. Pipet 5 mL of this solution, add a mixture of acetonitrile and water (9:1) to make exactly 50 mL, and use this solution as the standard solution. Determine the absorbances, A_T and A_S , at 355 nm of the sample solution and standard solution as directed under Ultraviolet-visible Spectrophotometry <2.24> using a mixture of acetonitrile and water (9:1) as the control.

$$\begin{aligned} &\text{Amount (mg) of cilnidipine (C}_{27}\text{H}_{28}\text{N}_2\text{O}_7) \\ &= M_S \times A_T/A_S \times V/100 \end{aligned}$$

M_S : Amount (mg) of Cilnidipine RS taken

Dissolution <6.10> When the test is performed at 75 revolutions per minute according to the Paddle method, using 900 mL of a solution of polysorbate 80 (dissolving 1 g of polysorbate 80 in 1000 mL of 2nd fluid for dissolution test) as the dissolution medium, the dissolution rate in 90 minutes of Cilnidipine Tablets is not less than 70%.

Start the test with 1 tablet of Cilnidipine Tablets, withdraw not less than 20 mL of the medium at the specified minute after starting the test, and filter through a membrane filter with a pore size not exceeding 0.45 μm . Discard not less than 10 mL of the first filtrate, pipet V mL of the subsequent

filtrate, add the dissolution medium to make exactly V' mL so that each mL contains about $5.6 \mu\text{g}$ of cilnidipine ($\text{C}_{27}\text{H}_{28}\text{N}_2\text{O}_7$), and use this solution as the sample solution. Separately, weigh accurately about 28 mg of Cilnidipine RS, previously dried in vacuum at 60°C for 3 hours, dissolve in acetonitrile to make exactly 100 mL. Pipet 2 mL of this solution, add the dissolution medium to make exactly 100 mL, and use this solution as the standard solution. Perform the test with exactly $20 \mu\text{L}$ each of the sample solution and standard solution as directed under Liquid Chromatography <2.01> according to the following conditions, and determine the peak areas, A_T and A_S , of cilnidipine in each solution.

Dissolution rate (%) with respect to the labeled amount of cilnidipine ($\text{C}_{27}\text{H}_{28}\text{N}_2\text{O}_7$)

$$= M_S \times A_T / A_S \times V' / V \times 1 / C \times 18$$

M_S : Amount (mg) of Cilnidipine RS taken

C : Labeled amount (mg) of cilnidipine ($\text{C}_{27}\text{H}_{28}\text{N}_2\text{O}_7$) in 1 tablet

Operating conditions—

Detector: An ultraviolet absorption photometer (wavelength: 240 nm).

Column: A stainless steel column 4.6 mm in inside diameter and 15 cm in length, packed with octadecylsilanized silica gel for liquid chromatography ($5 \mu\text{m}$ in particle diameter).

Column temperature: A constant temperature of about 40°C .

Mobile phase: Dissolve 3.58 g of disodium hydrogen phosphate dodecahydrate in 1000 mL of water, and adjust to pH 6.0 with phosphoric acid. To 400 mL of this solution add 600 mL of acetonitrile.

Flow rate: Adjust so that the retention time of cilnidipine is about 8 minutes.

System suitability—

System performance: When the procedure is run with $20 \mu\text{L}$ of the standard solution under the above operating conditions, the number of theoretical plates and the symmetry factor of the peak of cilnidipine are not less than 2000 and not more than 2.0, respectively.

System repeatability: When the test is repeated 6 times with $20 \mu\text{L}$ of the standard solution under the above operating conditions, the relative standard deviation of the peak area of cilnidipine is not more than 2.0%.

Assay Conduct this procedure using light-resistant vessels. Weigh accurately the mass of not less than 20 Cilnidipine Tablets, and powder. Weigh accurately a portion of the powder, equivalent to about 25 mg of cilnidipine ($\text{C}_{27}\text{H}_{28}\text{N}_2\text{O}_7$), add 40 mL of the mobile phase, shake well, and add the mobile phase to make exactly 50 mL. Centrifuge this solution, pipet 5 mL of the supernatant liquid, add exactly 2.5 mL of the internal standard solution, add the mobile phase to make 25 mL, and use this solution as the sample solution. Separately, weigh accurately about 25 mg of Cilnidipine RS, previously dried in vacuum at 60°C for 3 hours, dissolve in the mobile phase to make exactly 50 mL. Pipet 5 mL of this solution, add exactly 2.5 mL of the internal standard solution, add the mobile phase to make 25 mL, and use this solution as the standard solution. Perform the test with $10 \mu\text{L}$ each of the sample solution and standard solution as directed under Liquid Chromatography <2.01> according to the following conditions, and calculate the ratios, Q_T and Q_S , of the peak area of cilnidipine to that of the internal standard.

Amount (mg) of cilnidipine ($\text{C}_{27}\text{H}_{28}\text{N}_2\text{O}_7$) = $M_S \times Q_T / Q_S$

M_S : Amount (mg) of Cilnidipine RS taken

Internal standard solution—A solution of 4,4'-difluorobenzophenone in the mobile phase (1 in 500).

Operating conditions—

Detector: An ultraviolet absorption photometer (wavelength: 240 nm).

Column: A stainless steel column 6 mm in inside diameter and 30 cm in length, packed with octadecylsilanized silica gel for liquid chromatography ($5 \mu\text{m}$ in particle diameter).

Column temperature: A constant temperature of about 40°C .

Mobile phase: Dissolve 3.58 g of disodium hydrogen phosphate dodecahydrate in 1000 mL of water, and adjust to pH 6.0 with phosphoric acid. To 400 mL of this solution add 600 mL of acetonitrile.

Flow rate: Adjust so that the retention time of cilnidipine is about 23 minutes.

System suitability—

System performance: When the procedure is run with $10 \mu\text{L}$ of the standard solution under the above operating conditions, the internal standard and cilnidipine are eluted in this order with the resolution between these peaks being not less than 15.

System repeatability: When the test is repeated 6 times with $10 \mu\text{L}$ of the standard solution under the above operating conditions, the relative standard deviation of the ratio of the peak area of cilnidipine to that of the internal standard is not more than 1.0%.

Containers and storage Containers—Tight containers.

Storage—Light-resistant.

Cilostazol

シロスタゾール

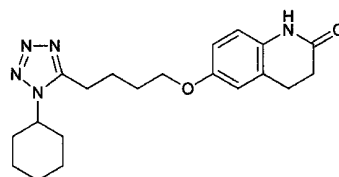

$\text{C}_{20}\text{H}_{27}\text{N}_5\text{O}_2$: 369.46

6-[4-(1-Cyclohexyl-1H-tetrazol-5-yl)butyloxy]-3,4-dihydroquinolin-2(1H)-one
[73963-72-1]

Cilostazol, when dried, contains not less than 98.5% and not more than 101.5% of cilostazol ($\text{C}_{20}\text{H}_{27}\text{N}_5\text{O}_2$).

Description Cilostazol occurs as white to pale yellow-white, crystals or crystalline powder.

It is slightly soluble in methanol, in ethanol (99.5) and in acetonitrile, and practically insoluble in water.

Identification (1) Determine the absorption spectrum of a solution of Cilostazol in methanol (1 in 100,000) as directed under Ultraviolet-visible Spectrophotometry <2.24>, and compare the spectrum with the Reference Spectrum or the spectrum of a solution of Cilostazol RS prepared in the same manner as the sample solution: both spectra exhibit similar intensities of absorption at the same wavelengths.

(2) Determine the infrared absorption spectrum of Cilostazol as directed in the potassium bromide disk method under Infrared Spectrophotometry <2.25>, and compare the spectrum with the Reference Spectrum or the spectrum of Cilostazol RS: both spectra exhibit similar intensities of absorption at the same wave numbers.

Melting point <2.60> 158 – 162°C

Purity (1) Heavy metals <1.07>—Proceed with 2.0 g of Cilostazol according to Method 2, and perform the test. Prepare the control solution with 2.0 mL of Standard Lead Solution (not more than 10 ppm).

(2) Related substances—Dissolve 25 mg of Cilostazol in 25 mL of acetonitrile, and use this solution as the sample solution. Pipet 1 mL of the sample solution, and add acetonitrile to make exactly 100 mL. Pipet 10 mL of this solution, add acetonitrile to make exactly 50 mL, and use this solution as the standard solution. Perform the test with exactly 10 µL each of the sample solution and standard solution as directed under Liquid Chromatography <2.01> according to the following conditions, and determine each peak area by the automatic integration method: the area of the peak other than cilostazol obtained from the sample solution is not larger than 7/10 times the peak area of cilostazol from the standard solution, and the total area of the peaks other than the peak of cilostazol from the sample solution is not larger than 1.2 times the peak area of cilostazol from the standard solution.

Operating conditions—

Detector: An ultraviolet absorption photometer (wavelength: 254 nm).

Column: A stainless steel column 4.6 mm in inside diameter and 15 cm in length, packed with silica gel for liquid chromatography (5 µm in particle diameter).

Column temperature: A constant temperature of about 25°C.

Mobile phase: A mixture of hexane, ethyl acetate and methanol (10:9:1).

Flow rate: Adjust so that the retention time of cilostazol is about 7 minutes.

Time span of measurement: About 3 times as long as the retention time of cilostazol, beginning after the solvent peak.

System suitability—

Test for required detectability: Pipet 1 mL of the standard solution, and add acetonitrile to make exactly 10 mL. Confirm that the peak area of cilostazol obtained with 10 µL of this solution is equivalent to 7 to 13% of that with 10 µL of the standard solution.

System performance: To 1 mL of the sample solution, add 1 mL of a solution prepared by dissolving 5 mg of 3,4-dihydro-6-hydroxy-2(1*H*)-quinolinone in 10 mL of acetonitrile and acetonitrile to make 100 mL. When the procedure is run with 10 µL of this solution under the above operating conditions, 3,4-dihydro-6-hydroxy-2(1*H*)-quinolinone and cilostazol are eluted in this order with the resolution between these peaks being not less than 9.

System repeatability: When the test is repeated 6 times with 10 µL of the standard solution under the above operating conditions, the relative standard deviation of the peak area of cilostazol is not more than 2.0%.

Loss on drying <2.41> Not more than 0.1% (1 g, 105°C, 2 hours).

Residue on ignition <2.44> Not more than 0.1% (1 g).

Assay Weigh accurately about 50 mg each of Cilostazol and Cilostazol RS, previously dried, dissolve each in a suitable amount of methanol, add exactly 5 mL of the internal standard solution and methanol to make 50 mL. To 1 mL each of these solutions add methanol to make 10 mL, and use these solutions as the sample solution and the standard solution, respectively. Perform the test with 10 µL each of the sample solution and standard solution as directed under Liquid Chromatography <2.01> according to the following conditions, and calculate the ratios, Q_T and Q_S , of the peak

area of cilostazol to that of the internal standard.

$$\text{Amount (mg) of cilostazol (C}_{20}\text{H}_{27}\text{N}_5\text{O}_2) = M_S \times Q_T/Q_S$$

M_S : Amount (mg) of Cilostazol RS taken

Internal standard solution—A solution of benzophenone in methanol (1 in 250).

Operating conditions—

Detector: An ultraviolet absorption photometer (wavelength: 254 nm).

Column: A stainless steel column 4.6 mm in inside diameter and 15 cm in length, packed with octadecylsilanized silica gel for liquid chromatography (5 µm in particle diameter).

Column temperature: A constant temperature of about 25°C.

Mobile phase: A mixture of water, acetonitrile and methanol (10:7:3).

Flow rate: Adjust so that the retention time of cilostazol is about 9 minutes.

System suitability—

System performance: When the procedure is run with 10 µL of the standard solution under the above operating conditions, cilostazol and the internal standard are eluted in this order with the resolution between these peaks being not less than 9.

System repeatability: When the test is repeated 5 times with 10 µL of the standard solution under the above operating conditions, the relative standard deviation of the ratio of the peak area of cilostazol to that of the internal standard is not more than 1.0%.

Containers and storage Containers—Well-closed containers.

Cilostazol Tablets

シロスタゾール錠

Cilostazol Tablets contain not less than 95.0% and not more than 105.0% of the labeled amount of cilostazol (C₂₀H₂₇N₅O₂; 369.46).

Method of preparation Prepare as directed under Tablets, with Cilostazol.

Identification Mix well an amount of powdered Cilostazol Tablets, equivalent to 50 mg of Cilostazol, with 10 mL of acetone, centrifuge, and use the supernatant liquid as the sample solution. Separately, dissolve 25 mg of Cilostazol RS in 5 mL of acetone, and use this solution as the standard solution. Perform the test with these solutions as directed under Thin-layer Chromatography <2.03>. Spot 6 µL each of the sample solution and standard solution on a plate of silica gel for thin-layer chromatography, develop the plate with a mixture of ethyl acetate, acetonitrile, methanol and formic acid (75:25:5:1) to a distance of about 12 cm, and air-dry the plate. Spray evenly Dragendorff's TS for spraying on the plate: the principal spot obtained from the sample solution and the spot from the standard solution are orange in color and have the same R_f value.

Uniformity of dosage units <6.02> Perform the Mass variation test, or the Content uniformity test according to the following method: it meets the requirement.

To 1 tablet of Cilostazol Tablets add 2 mL of water to disintegrate the tablet, add the internal standard solution exactly 5 mL for a 50-mg tablet and exactly 10 mL for a 100-mg tablet, and add methanol to make 50 mL. Shake for

10 minutes for the 50-mg tablet and for 20 minutes for the 100-mg tablet. To 1 mL of the solution add methanol to make 10 mL for the 50-mg tablet and 20 mL for the 100-mg tablet, filter through a membrane filter with a pore size not exceeding 0.5 μm , and use the filtrate as the sample solution. Proceed as directed in the Assay.

$$\begin{aligned} &\text{Amount (mg) of cimetazol (C}_{20}\text{H}_{27}\text{N}_5\text{O}_2) \\ &= M_S \times Q_T/Q_S \times C/50 \end{aligned}$$

M_S : Amount (mg) of Cimetazol RS taken

C : Labeled amount (mg) of cimetazol (C₂₀H₂₇N₅O₂) in 1 tablet

Internal standard solution—A solution of benzophenone in methanol (1 in 250).

Dissolution <6.10> When the test is performed at 50 revolutions per minute according to the Paddle method, using 900 mL of a solution of sodium lauryl sulfate (3 in 1000) as the dissolution medium, the dissolution rates of a 50-mg tablet in 45 minutes and a 100-mg tablet in 60 minutes are not less than 75% and not less than 70%, respectively.

Start the test with 1 tablet of Cimetazol Tablets, withdraw not less than 20 mL of the medium at the specified minute after starting the test, and filter through a membrane filter with a pore size not exceeding 0.45 μm . Discard not less than 10 mL of the first filtrate, pipet V mL of the subsequent filtrate, add the dissolution medium to make exactly V' mL so that each mL contains about 5.6 μg of cimetazol (C₂₀H₂₇N₅O₂), and use this solution as the sample solution. Separately, weigh accurately about 28 mg of Cimetazol RS, previously dried at 105°C for 2 hours, and dissolve in methanol to make exactly 100 mL. Pipet 4 mL of this solution, add the dissolution medium to make exactly 200 mL, and use this solution as the standard solution. Determine the absorbances, A_T and A_S , of the sample solution and standard solution at 257 nm as directed under Ultraviolet-visible Spectrophotometry <2.24> using the dissolution medium as the control.

$$\begin{aligned} &\text{Dissolution rate (\%)} \text{ with respect to the labeled amount} \\ &\text{of cimetazol (C}_{20}\text{H}_{27}\text{N}_5\text{O}_2) \\ &= M_S \times A_T/A_S \times V'/V \times 1/C \times 18 \end{aligned}$$

M_S : Amount (mg) of Cimetazol RS taken

C : Labeled amount (mg) of cimetazol (C₂₀H₂₇N₅O₂) in 1 tablet

Assay Weigh accurately the mass of not less than 20 Cimetazol Tablets, and powder. Weigh accurately a portion of the powder, equivalent to about 50 mg of cimetazol (C₂₀H₂₇N₅O₂), add exactly 5 mL of the internal standard solution and methanol to make 50 mL, and shake well for 10 minutes. To 1 mL of this solution add methanol to make 10 mL, filter through a membrane filter with a pore size not exceeding 0.5 μm , and use the filtrate as the sample solution. Separately, weigh accurately about 50 mg of Cimetazol RS, previously dried at 105°C for 2 hours, dissolve in a suitable amount of methanol, and add exactly 5 mL of the internal standard solution, and add methanol to make 50 mL. To 1 mL of this solution add methanol to make 10 mL, and use this solution as the standard solution. Perform the test with 10 μL each of the sample solution and standard solution as directed under Liquid Chromatography <2.01> according to the following conditions, and calculate the ratios, Q_T and Q_S , of the peak area of cimetazol to that of the internal standard.

$$\text{Amount (mg) of cimetazol (C}_{20}\text{H}_{27}\text{N}_5\text{O}_2) = M_S \times Q_T/Q_S$$

M_S : Amount (mg) of Cimetazol RS taken

Internal standard solution—A solution of benzophenone in methanol (1 in 250).

Operating conditions—

Proceed as directed in the operating conditions in the Assay under Cimetazol.

System suitability—

System performance: Proceed as directed in the system suitability in the Assay under Cimetazol.

System repeatability: When the test is repeated 6 times with 10 μL of the standard solution under the above operating conditions, the relative standard deviation of the ratio of the peak area of cimetazol to that of the internal standard is not more than 1.5%.

Containers and storage Containers—Well-closed containers.

Cimetidine

シメチジン

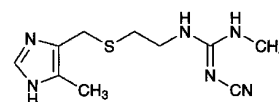

C₁₀H₁₆N₆S: 252.34

2-Cyano-1-methyl-3-[(5-methyl-1H-imidazol-4-yl)methylsulfanyl]ethylguanidine
[51481-61-9]

Cimetidine, when dried, contains not less than 99.0% of cimetidine (C₁₀H₁₆N₆S).

Description Cimetidine occurs as a white crystalline powder. It is odorless, and has a bitter taste.

It is freely soluble in methanol and in acetic acid (100), sparingly soluble in ethanol (95), slightly soluble in water, and practically insoluble in diethyl ether.

It dissolves in dilute hydrochloric acid.

It is gradually colored by light.

Identification (1) To 0.1 mL of a solution of Cimetidine in ethanol (95) (1 in 100) add 5 mL of citric acid-acetic anhydride TS, and heat in a water bath for 15 minutes: a red-purple color develops.

(2) Determine the infrared absorption spectrum of Cimetidine, previously dried, as directed in the potassium bromide disk method under the Infrared Spectrophotometry <2.25>, and compare the spectrum with the Reference Spectrum: both spectra exhibit similar intensities of absorption at the same wave numbers.

pH <2.54> Dissolve 0.5 g of Cimetidine in 50 mL of freshly boiled and cooled water, shake for 5 minutes and filter: the pH of the filtrate is between 9.0 and 10.5.

Melting point <2.60> 140 – 144°C

Purity (1) Clarity and color of solution—Dissolve 1.0 g of Cimetidine in 10 mL of methanol: the solution is clear and colorless to pale yellow in color.

(2) Heavy metals <1.07>—Proceed with 2.0 g of Cimetidine according to Method 2, and perform the test. Prepare the control solution with 2.0 mL of Standard Lead Solution (not more than 10 ppm).

(3) Arsenic <1.11>—Dissolve 1.0 g of Cimetidine in 5 mL of dilute hydrochloric acid, and perform the test with this so-

lution (not more than 2 ppm).

(4) Related substances—Dissolve 0.5 g of Cimetidine in 10 mL of methanol, and use this solution as the sample solution. Pipet 1 mL of the sample solution, add methanol to make exactly 100 mL. Pipet 1 mL of this solution, add methanol to make exactly 10 mL, and use this solution as the standard solution. Perform the test with these solutions as directed under Thin-layer Chromatography <2.03>. Spot 4 μ L each of the sample solution and standard solution on a plate of silica gel for thin-layer chromatography. Develop the plate with a mixture of ethyl acetate, methanol and ammonia solution (28) (21:2:2) to a distance of about 15 cm, air-dry the plate, and then dry at 80°C for 30 minutes. Allow the plate to stand in iodine vapor for 45 minutes: the spots other than the principal spot obtained from the sample solution are not more intense than the spot from the standard solution.

Loss on drying <2.41> Not more than 0.5% (1 g, 105°C, 3 hours).

Residue on ignition <2.44> Not more than 0.2% (1 g).

Assay Weigh accurately about 0.24 g of Cimetidine, previously dried, dissolve in 75 mL of acetic acid (100), and titrate <2.50> with 0.1 mol/L perchloric acid VS (potentiometric titration). Perform a blank determination in the same manner, and make any necessary correction.

Each mL of 0.1 mol/L perchloric acid VS
= 25.23 mg of C₁₀H₁₆N₆S

Containers and storage Containers—Well-closed containers.

Storage—Light-resistant.

Cinoxacin

シノキサシン

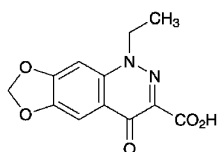

C₁₂H₁₀N₂O₅; 262.22

5-Ethyl-8-oxo-5,8-dihydro[1,3]dioxolo[4,5-g]cinnoline-7-carboxylic acid
[28657-80-9]

Cinoxacin, when dried, contains not less than 98.0% and not more than 101.0% of cinoxacin (C₁₂H₁₀N₂O₅).

Description Cinoxacin occurs as a white to pale yellow crystalline powder. It is odorless or has a slight, characteristic odor. It has a bitter taste.

It is slightly soluble in *N,N*-dimethylformamide and in acetone, very slightly soluble in ethanol (99.5), and practically insoluble in water.

It dissolves in sodium hydroxide TS.

Melting point: about 265°C (with decomposition).

Identification (1) Dissolve 30 mg of Cinoxacin in 10 mL of dilute sodium hydroxide TS, and add water to make 100 mL. To 1 mL of this solution add 0.1 mol/L hydrochloric acid TS to make 50 mL. Determine the absorption spectrum of this solution as directed under Ultraviolet-visible Spectrophotometry <2.24>, and compare the spectrum with the Ref-

erence Spectrum: both spectra exhibit similar intensities of absorption at the same wavelengths.

(2) Determine the infrared absorption spectrum of Cinoxacin as directed in the potassium bromide disk method under Infrared Spectrophotometry <2.25>, and compare the spectrum with the Reference Spectrum: both spectra exhibit similar intensities of absorption at the same wave numbers.

Purity (1) Sulfate <1.14>—Dissolve 0.20 g of Cinoxacin in 10 mL of dilute sodium hydroxide TS, add 20 mL of 0.1 mol/L hydrochloric acid TS, shake, filter, and add water to the filtrate to make 50 mL. Perform the test using this solution as the test solution. Prepare the control solution with 0.20 mL of 0.005 mol/L sulfuric acid VS by adding 10 mL of dilute sodium hydroxide TS, 20 mL of 0.1 mol/L hydrochloric acid TS, and water to make 50 mL (not more than 0.048%).

(2) Heavy metals <1.07>—Proceed with 1.0 g of Cinoxacin according to Method 2, and perform the test. Prepare the control solution with 2.0 mL of Standard Lead Solution (not more than 20 ppm).

(3) Related substances—Dissolve 10 mg of Cinoxacin in 10 mL of acetone, and use this solution as the sample solution. Pipet 1 mL of the sample solution, add acetone to make exactly 200 mL, and use this solution as the standard solution. Perform the test with these solutions as directed under Thin-layer Chromatography <2.03>. Spot 10 μ L each of the sample solution and standard solution on a plate of silica gel with fluorescent indicator for thin-layer chromatography. Develop the plate with a mixture of acetonitrile, water and ammonia solution (28) (14:4:1) to a distance of about 10 cm, and air-dry the plate. Examine under ultraviolet light (main wavelength: 254 nm): the spots other than the principal spot obtained from the sample solution are not more intense than the spot from the standard solution.

Loss on drying <2.41> Not more than 0.5% (1 g, 105°C, 1 hour).

Residue on ignition <2.44> Not more than 0.2% (1 g).

Assay Weigh accurately about 0.4 g of Cinoxacin, previously dried, add 60 mL of a mixture of acetic anhydride and acetic acid (100) (7:3), and dissolve by warming. After cooling, titrate <2.50> with 0.1 mol/L perchloric acid VS (potentiometric titration). Perform a blank determination in the same manner, and make any necessary correction.

Each mL of 0.1 mol/L perchloric acid VS
= 26.22 mg of C₁₂H₁₀N₂O₅

Containers and storage Containers—Tight containers.

Cinoxacin Capsules

シノキサシンカプセル

Cinoxacin Capsules contain not less than 95.0% and not more than 105.0% of the labeled amount of cinoxacin (C₁₂H₁₀N₂O₅; 262.22).

Method of preparation Prepare as directed under Capsules, with Cinoxacin.

Identification To a quantity of the contents of Cinoxacin Capsules, equivalent to 10 mg of Cinoxacin, add 20 mL of acetone, shake well, and centrifuge. To 3 mL of the supernatant liquid add acetone to make 10 mL, and use this solution as the sample solution. Separately, dissolve 10 mg of cinoxacin

cin for assay in 20 mL of acetone. To 3 mL of this solution add acetone to make 10 mL, and use this solution as the standard solution. Perform the test with these solutions as directed under Thin-layer Chromatography <2.03>. Spot 10 μ L each of the sample solution and standard solution on a plate of silica gel with fluorescent indicator for thin-layer chromatography. Develop the plate with a mixture of acetonitrile, water and ammonia solution (28) (14:4:1) to a distance of about 10 cm, and air-dry the plate. Examine under ultraviolet light (main wavelength: 254 nm): the principal spot obtained from the sample solution and the spot from the standard solution show a blue-purple color and the same R_f value.

Uniformity of dosage units <6.02> Perform the test according to the following method: it meets the requirement of the Content uniformity test.

To 1 capsule of Cinoxacin Capsules add 40 mL of dilute sodium hydroxide TS, and dissolve the capsule in lukewarm water with occasional shaking. After cooling, add water and shake well, add water to make exactly V mL so that each mL contains about 1 mg of cinoxacin ($C_{12}H_{10}N_2O_5$), and filter. Discard the first 20 mL of the filtrate, pipet 1 mL of the subsequent filtrate, add 0.1 mol/L hydrochloric acid TS to make exactly 100 mL, and use this solution as the sample solution. Separately, weigh accurately about 0.2 g of cinoxacin for assay, previously dried at 105°C for 1 hour, dissolve in 40 mL of dilute sodium hydroxide TS, and add water to make exactly 200 mL. Pipet 1 mL of this solution, add 0.1 mol/L of hydrochloric acid TS to make exactly 100 mL, and use this solution as the standard solution. Perform the test with the sample solution and standard solution as directed under Ultraviolet-visible Spectrophotometry <2.24>, and determine the absorbances, A_T and A_S , at 354 nm.

$$\begin{aligned} \text{Amount (mg) of cinoxacin (C}_{12}\text{H}_{10}\text{N}_2\text{O}_5) \\ = M_S \times A_T/A_S \times V/200 \end{aligned}$$

M_S : Amount (mg) of cinoxacin for assay taken

Dissolution <6.10> When the test is performed at 50 revolutions per minute according to the Paddle method using the sinker, using 900 mL of 2nd solution for dissolution test as the dissolution medium, the dissolution rate in 90 minutes of Cinoxacin Capsules is not less than 70%.

Start the test with 1 capsule of Cinoxacin Capsules, withdraw not less than 20 mL of the medium at the specified minute after starting the test, and filter through a membrane filter with a pore size not exceeding 0.45 μ m. Discard not less than 10 mL of the first filtrate, pipet V mL of the subsequent filtrate, add the dissolution medium to make exactly V' mL so that each mL contains about 11 μ g of cinoxacin ($C_{12}H_{10}N_2O_5$), and use this solution as the sample solution. Separately, weigh accurately about 22 mg of cinoxacin for assay, previously dried at 105°C for 1 hour, and dissolve in the dissolution medium to make exactly 100 mL. Pipet 5 mL of this solution, add the dissolution medium to make exactly 100 mL, and use this solution as the standard solution. Perform the test with the sample solution and standard solution as directed under Ultraviolet-visible Spectrophotometry <2.24>, and determine the absorbances, A_T and A_S , at 351 nm.

Dissolution rate (%) with respect to the labeled amount of cinoxacin ($C_{12}H_{10}N_2O_5$)

$$= M_S \times A_T/A_S \times V'/V \times 1/C \times 45$$

M_S : Amount (mg) of cinoxacin for assay taken

C : Labeled amount (mg) of cinoxacin ($C_{12}H_{10}N_2O_5$) in 1 capsule

Assay Weigh accurately the mass of not less than 20 Cinoxacin Capsules, take out the contents, and powder. Wash the capsule shells with a small amount of diethyl ether, allow to stand at room temperature to vaporize the diethyl ether, weigh accurately the mass of the capsule shells, and calculate the mass of the contents. Weigh accurately a portion of the powder, equivalent to about 50 mg of cinoxacin ($C_{12}H_{10}N_2O_5$), add 10 mL of dilute sodium hydroxide TS, shake, add water to make exactly 100 mL, and filter. Discard the first 20 mL of the filtrate, pipet 1 mL of the subsequent filtrate, add 0.1 mol/L hydrochloric acid TS to make exactly 50 mL, and use this solution as the sample solution. Separately, weigh accurately about 50 mg of cinoxacin for assay, previously dried at 105°C for 1 hour, dissolve in 10 mL of dilute sodium hydroxide TS, and add water to make exactly 100 mL. Pipet 1 mL of this solution, add 0.1 mol/L hydrochloric acid TS to make exactly 50 mL, and use this solution as the standard solution. Perform the test with the sample solution and standard solution as directed under Ultraviolet-visible Spectrophotometry <2.24>, and determine the absorbances, A_T and A_S , at 354 nm.

$$\begin{aligned} \text{Amount (mg) of cinoxacin (C}_{12}\text{H}_{10}\text{N}_2\text{O}_5) \\ = M_S \times A_T/A_S \end{aligned}$$

M_S : Amount (mg) of cinoxacin for assay taken

Containers and storage Containers—Well-closed containers.

Ciprofloxacin

シプロフロキサシン

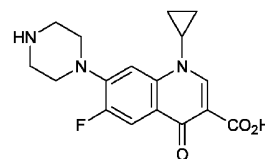

$C_{17}H_{18}FN_3O_3$: 331.34

1-Cyclopropyl-6-fluoro-4-oxo-7-(piperazin-1-yl)-1,4-dihydroquinoline-3-carboxylic acid
[8572I-33-I]

Ciprofloxacin, when dried, contains not less than 98.5% and not more than 101.0% of ciprofloxacin ($C_{17}H_{18}FN_3O_3$).

Description Ciprofloxacin occurs as a white to light yellow-white, crystalline powder.

It is practically insoluble in water and in ethanol (99.5).

It dissolves in ammonia TS.

It is gradually colored to yellow tint by light.

Melting point: about 270°C (with decomposition).

Identification (1) Determine the infrared absorption spectrum of Ciprofloxacin, as directed in the potassium bromide disk method under Infrared Spectrophotometry <2.25>, and compare the spectrum with the Reference Spectrum or the spectrum of the Ciprofloxacin RS: both spectra exhibit similar intensities of absorption at the same wave numbers.

(2) Conduct this procedure using light-resistant vessels. Dissolve 50 mg each of Ciprofloxacin and Ciprofloxacin RS in 5 mL of ammonia TS, and use these solutions as the sample solution and the standard solution, respectively. Perform the test with these solutions as directed under Thin-layer Chromatography <2.03>. Spot 5 μ L each of the sample solu-

tion and the standard solution on a plate of silica gel with fluorescent indicator for thin-layer chromatography. After allowing to stand this plate in the vapor of ammonia for 15 minutes, develop the plate with a mixture of methanol, dichloromethane, ammonia solution (28) and acetonitrile (4:4:2:1) to a distance of about 10 cm, and air-dry the plate. Examine under ultraviolet light (main wavelength: 254 nm): the principal spot obtained from the sample solution and the spot from the standard solution show the same R_f value.

Purity (1) Chloride <1.03>—To 1.5 g of Ciprofloxacin add 75 mL of water, and boil for 5 minutes. After cooling, add water to make 75 mL, and filter. To 25 mL of the filtrate add 6 mL of dilute nitric acid and water to make 50 mL. Perform the test using this solution as the test solution. Prepare the control solution as follows: to 0.30 mL of 0.01 mol/L hydrochloric acid VS add 6 mL of dilute sulfuric acid and water to make 50 mL (not more than 0.021%).

(2) Heavy metals <1.07>—Proceed with 2.0 g of Ciprofloxacin according to Method 4, and perform the test. Prepare the control solution with 2.0 mL of Standard Lead Solution (not more than 10 ppm).

(3) Fluoroquinolonic acid—Conduct this procedure using light-resistant vessels. Dissolve 50 mg of Ciprofloxacin in ammonia TS to make exactly 5 mL, and use this solution as the sample solution. Separately, dissolve 10 mg of fluoroquinolonic acid for thin-layer chromatography in 0.1 mL of ammonia TS and water to make exactly 100 mL. Pipet 2 mL of this solution, add water to make exactly 10 mL, and use this solution as the standard solution. Perform the test with these solutions as directed under Thin-layer Chromatography <2.03>. Spot 5 μL each of the sample solution and the standard solution on a plate of silica gel with fluorescent indicator for thin-layer chromatography. After allowing to stand this plate in the vapor of ammonia for 15 minutes, develop the plate with a mixture of methanol, dichloromethane, ammonia solution (28) and acetonitrile (4:4:2:1) to a distance of about 10 cm, and air-dry the plate. Examine under ultraviolet light (main wavelength: 254 nm): the spot obtained from the sample solution, corresponding to the spot obtained from the standard solution, is not more intense than that obtained from the standard solution.

(4) Related substances—Conduct this procedure using light-resistant vessels. To 25 mg of Ciprofloxacin add 2 mL of a mixture of water and phosphoric acid (13:1), then add the mobile phase to make 50 mL, and use this solution as the sample solution. Pipet 2 mL of the sample solution, add the mobile phase to make exactly 20 mL. Pipet 1 mL of this solution, add the mobile phase to make exactly 50 mL, and use this solution as the standard solution. Perform the test with exactly 50 μL each of the sample solution and standard solution as directed under Liquid Chromatography <2.01> according to the following conditions. Determine each peak area by the automatic integration method: the area of the peak other than ciprofloxacin obtained from the sample solution is not larger than the peak area of ciprofloxacin from the standard solution, and the total area of the peaks other than ciprofloxacin from the sample solution is not larger than 2.5 times the peak area of ciprofloxacin from the standard solution. For the area of peak, having the relative retention time of about 0.4, about 0.5, and about 1.2 to ciprofloxacin, multiply the correction factor, 6.7, 1.3, and 1.4, respectively.

Operating conditions—

Detector, column, column temperature, mobile phase, and flow rate: Proceed as directed in the operating conditions in the Assay.

Time span of measurement: About 2.3 times as long as the retention time of ciprofloxacin, beginning after the solvent peak.

System suitability—

Test for required detectability: Pipet 5 mL of the standard solution, and add the mobile phase to make exactly 20 mL. Confirm that the peak area of ciprofloxacin obtained with 50 μL of this solution is equivalent to 20 to 30% of that with 50 μL of the standard solution.

System performance: When the procedure is run with 50 μL of the standard solution under the above operating conditions, the number of theoretical plates and the symmetry factor of the peak of ciprofloxacin are not less than 3500 and not more than 1.5, respectively.

System repeatability: When the test is repeated 6 times with 50 μL of the standard solution under the above operating conditions, the relative standard deviation of the peak area of ciprofloxacin is not more than 2.0%.

Loss on drying <2.41> Not more than 1.0% (2 g, in vacuum, 120°C, 6 hours).

Residue on ignition <2.44> Not more than 0.1% (2 g).

Assay Conduct this procedure using light-resistant vessels. Weigh accurately about 25 mg each of Ciprofloxacin and Ciprofloxacin RS, both dried previously, add 2 mL of a mixture of water and phosphoric acid (13:1), add the mobile phase to make exactly 50 mL, and use these solutions as the sample solution and the standard solution, respectively. Perform the test with exactly 10 μL each of the sample solution and standard solution as directed under Liquid Chromatography <2.01> according to the following conditions, and determine the peak areas, A_T and A_S , of ciprofloxacin in each solution.

$$\begin{aligned} &\text{Amount (mg) of ciprofloxacin (C}_{17}\text{H}_{18}\text{FN}_3\text{O}_3) \\ &= M_S \times A_T/A_S \end{aligned}$$

M_S : Amount (mg) of Ciprofloxacin RS taken

Operating conditions—

Detector: An ultraviolet absorption photometer (wavelength: 278 nm).

Column: A stainless steel column 4 mm in inside diameter and 25 cm in length, packed with octadecylsilanized silica gel for liquid chromatography (5 μm in particle diameter).

Column temperature: A constant temperature of about 40°C.

Mobile phase: To 2.88 g of phosphoric acid add water to make 1000 mL, and adjust to pH 3.0 with triethylamine. To 870 mL of this solution add 130 mL of acetonitrile.

Flow rate: Adjust so that the retention time of ciprofloxacin is about 7 minutes.

System suitability—

System performance: When the procedure is run with 10 μL of the standard solution under the above operating conditions, the number of theoretical plates and the symmetry factor of the peak of ciprofloxacin are not less than 3500 and not more than 2.0, respectively.

System repeatability: When the test is repeated 6 times with 10 μL of the standard solution under the above operating conditions, the relative standard deviation of the peak area of ciprofloxacin is not more than 1.0%.

Containers and storage Containers—Tight containers.

Storage—Light-resistant.

Ciprofloxacin Hydrochloride Hydrate

シプロフロキサシン塩酸塩水和物

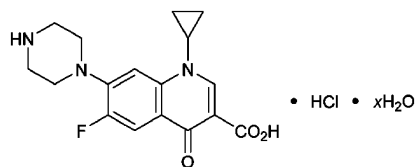

C₁₇H₁₈FN₃O₃·HCl·xH₂O

1-Cyclopropyl-6-fluoro-4-oxo-7-(piperazin-1-yl)-

1,4-dihydroquinoline-3-carboxylic acid monohydrochloride hydrate
[86393-32-0, monohydrochloride monohydrate]

Ciprofloxacin Hydrochloride Hydrate contains not less than 98.0% and not more than 102.0% of ciprofloxacin hydrochloride (C₁₇H₁₈FN₃O₃·HCl: 367.80), calculated on the anhydrous basis.

Description Ciprofloxacin Hydrochloride Hydrate occurs as a white to pale yellow crystalline powder.

It is sparingly soluble in water, slightly soluble in methanol, and very slightly soluble in ethanol (99.5).

It is gradually colored to a slightly brownish light yellow by light.

Identification (1) Determine the infrared absorption spectrum of Ciprofloxacin Hydrochloride Hydrate, as directed in the potassium chloride disk method under Infrared Spectrophotometry <2.25>, and compare the spectrum with the Reference Spectrum: both spectra exhibit similar intensities of absorption at the same wave numbers.

(2) Conduct this procedure using light-resistant vessels. Dissolve 50 mg of Ciprofloxacin Hydrochloride Hydrate in 5 mL of water, and use this solution as the sample solution. Separately, dissolve 45 mg of Ciprofloxacin RS in 5 mL of ammonia TS, and use this solution as the standard solution. Perform the test with these solutions, as directed under Thin-layer Chromatography <2.03>. Spot 5 μL each of the sample solution and standard solution on a plate of silica gel with fluorescent indicator for thin-layer chromatography. After allowing to stand the plate in the vapor of ammonia for 15 minutes, develop the plate with a mixture of methanol, dichloromethane, ammonia solution (28) and acetonitrile (4:4:2:1) to a distance of about 10 cm, and air-dry the plate. Examine under ultraviolet light (main wavelength: 254 nm): the principal spot obtained from the sample solution and the spot obtained from the standard solution show the same R_f value.

(3) A solution of Ciprofloxacin Hydrochloride Hydrate (1 in 500) responds to Qualitative Tests <1.09> for chloride.

Purity (1) Sulfate <1.14>—Perform the test with 0.5 g of Ciprofloxacin Hydrochloride Hydrate. Prepare the control solution with 0.50 mL of 0.005 mol/L sulfuric acid VS (not more than 0.048%).

(2) Heavy metals <1.07>—Proceed with 1.0 g of Ciprofloxacin Hydrochloride Hydrate according to Method 2, and perform the test. Prepare the control solution with 1.0 mL of Standard Lead Solution (not more than 10 ppm).

(3) Fluoroquinolonic acid—Conduct this procedure using light-resistant vessels. Dissolve 50 mg of Ciprofloxacin Hydrochloride Hydrate in water to make exactly 5 mL, and use this solution as the sample solution. Separately, dissolve 10 mg of fluoroquinolonic acid for thin-layer chroma-

phy in 0.1 mL of ammonia TS and water to make exactly 100 mL. Pipet 2 mL of this solution, add water to make exactly 10 mL, and use this solution as the standard solution. Perform the test with these solutions as directed under Thin-layer Chromatography <2.03>. Spot 5 μL each of the sample solution and standard solution on a plate of silica gel with fluorescent indicator for thin-layer chromatography. After allowing to stand the plate in the vapor of ammonia for 15 minutes, develop the plate with a mixture of methanol, dichloromethane, ammonia solution (28) and acetonitrile (4:4:2:1) to a distance of about 10 cm, and air-dry the plate. Examine under ultraviolet light (main wavelength: 254 nm): the spot obtained from the sample solution, corresponding to the spot from the standard solution, is not more intense than that from the standard solution.

(4) Related substances—Conduct this procedure using light-resistant vessels. Dissolve 25 mg of Ciprofloxacin Hydrochloride Hydrate in 50 mL of mobile phase, and use this solution as the sample solution. Pipet 2 mL of the sample solution, add the mobile phase to make exactly 20 mL. Pipet 1 mL of this solution, add the mobile phase to make exactly 50 mL, and use this solution as the standard solution. Perform the test with exactly 50 μL each of the sample solution and standard solution as directed under Liquid Chromatography <2.01> according to the following conditions. Determine each peak area by the automatic integration method: the area of the peaks other than ciprofloxacin obtained from the sample solution is not larger than the peak area of ciprofloxacin from the standard solution, and the total area of the peaks other than ciprofloxacin from the sample solution is not larger than 2.5 times the peak area of ciprofloxacin from the standard solution. For the area of the peaks, having the relative retention times of about 0.4, about 0.5, and about 1.2 to ciprofloxacin, multiply the correction factors, 6.7, 1.3, and 1.4, respectively.

Operating conditions—

Detector, column, column temperature, mobile phase, and flow rate: Proceed as directed in the operating conditions in the Assay.

Time span of measurement: About 2 times as long as the retention time of ciprofloxacin, beginning after the solvent peak.

System suitability—

Test for required detectability: Pipet 5 mL of the standard solution, and add the mobile phase to make exactly 20 mL. Confirm that the peak area of ciprofloxacin obtained with 50 μL of this solution is equivalent to 20 to 30% of that with 50 μL of the standard solution.

System performance: When the procedure is run with 50 μL of the standard solution under the above operating conditions, the number of theoretical plates and the symmetry factor of the peak of ciprofloxacin are not less than 3500 and not more than 1.5, respectively.

System repeatability: When the test is repeated 6 times with 50 μL of the standard solution under the above operating conditions, the relative standard deviation of the peak area of ciprofloxacin is not more than 2.0%.

Water <2.48> 4.7 – 6.7% (0.2 g, volumetric titration, direct titration).

Residue on ignition <2.44> Not more than 0.1% (1 g).

Assay Conduct this procedure using light-resistant vessels. Weigh accurately about 25 mg of Ciprofloxacin Hydrochloride Hydrate, dissolve in the mobile phase to make exactly 50 mL, and use this solution as the sample solution. Separately, weigh accurately about 22.5 mg of Ciprofloxacin RS, previ-

ously dried at 120°C in vacuum for 6 hours, add 2 mL of a mixture of water and phosphoric acid (13:1), then add the mobile phase to make exactly 50 mL, and use this solution as the standard solution. Perform the test with exactly 10 μ L each of the sample solution and standard solution as directed under Liquid Chromatography <2.01> according to the following operating conditions, and determine the peak areas, A_T and A_S , of ciprofloxacin in each solution.

$$\text{Amount (mg) of ciprofloxacin hydrochloride} \\ (\text{C}_{17}\text{H}_{18}\text{FN}_3\text{O}_3 \cdot \text{HCl}) = M_S \times A_T / A_S \times 1.110$$

M_S : Amount (mg) of Ciprofloxacin RS taken

Operating conditions—

Detector: An ultraviolet absorption photometer (wavelength: 278 nm).

Column: A stainless steel column 4 mm in inside diameter and 25 cm in length, packed with octadecylsilanized silica gel for liquid chromatography (5 μ m in particle diameter).

Column temperature: A constant temperature of about 40°C.

Mobile phase: To 2.88 g of phosphoric acid add water to make 1000 mL, and adjust to pH 3.0 with triethylamine. To 870 mL of this solution add 130 mL of acetonitrile for liquid chromatography.

Flow rate: Adjust so that the retention time of ciprofloxacin is about 7 minutes.

System suitability—

System performance: When the procedure is run with 10 μ L of the standard solution under the above operating conditions, the number of theoretical plates and the symmetry factor of the peak of ciprofloxacin are not less than 3500 and not more than 2.0, respectively.

System repeatability: When the test is repeated 6 times with 10 μ L of the standard solution under the above operating conditions, the relative standard deviation of the peak area of ciprofloxacin is not more than 1.0%.

Containers and storage Containers—Tight containers.
Storage—Light-resistant.

Cisplatin

シスプラチン

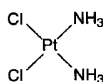

$\text{Cl}_2\text{H}_6\text{N}_2\text{Pt}$: 300.05
(SP-4-2)-Diamminedichloroplatinum
[15663-27-1]

Cisplatin, when dried, contains not less than 98.0% and not more than 102.0% of cisplatin ($\text{Cl}_2\text{H}_6\text{N}_2\text{Pt}$).

Description Cisplatin occurs as a yellow crystalline powder.

It is sparingly soluble in *N,N*-dimethylformamide, slightly soluble in water, and practically insoluble in ethanol (99.5).

Identification (1) To 5 mL of a solution of Cisplatin (1 in 2000) add 2 to 3 drops of a solution of tin (II) chloride dihydrate (1 in 100): a brown precipitate is formed.

(2) Determine the absorption spectrum of a solution of Cisplatin in a solution of sodium chloride in 0.01 mol/L hydrochloric acid TS (9 in 1000) (1 in 2000) as directed under Ultraviolet-visible Spectrophotometry <2.24>, and compare

the spectrum with the Reference Spectrum or the spectrum of a solution of Cisplatin RS prepared in the same manner as the sample solution: both spectra exhibit similar intensities of absorption at the same wavelengths.

(3) Determine the infrared absorption spectrum of Cisplatin as directed in the potassium bromide disk method under Infrared Spectrophotometry <2.25>, and compare the spectrum with the Reference Spectrum or the spectrum of Cisplatin RS: both spectra exhibit similar intensities of absorption at the same wave numbers.

(4) A solution of Cisplatin (1 in 2000) responds to Qualitative Tests <1.09> (1) for chloride.

Purity Ammonium aminotrichloroplatinate—Conduct this procedure using light-resistant vessels. Dissolve 50 mg of Cisplatin in a solution of sodium chloride (9 in 1000) to make exactly 100 mL, and use this solution as the sample solution. Separately, dissolve 10 mg of ammonium aminotrichloroplatinate for liquid chromatography, previously dried at 80°C for 3 hours, in the solution of sodium chloride (9 in 1000) to make exactly 200 mL. Pipet 2 mL of this solution, add the solution of sodium chloride (9 in 1000) to make exactly 20 mL, and use this solution as the standard solution. Perform the test with exactly 40 μ L each of the sample solution and standard solution as directed under Liquid Chromatography <2.01> according to the following conditions, and determine the peak area of ammonium aminotrichloroplatinate by the automatic integration method: the peak area obtained from the sample solution is not larger than that from the standard solution.

Operating conditions—

Detector: An ultraviolet absorption photometer (wavelength: 209 nm).

Column: A stainless steel column 4.6 mm in inside diameter and 25 cm in length, packed with silica gel for liquid chromatography having quaternary ammonium groups (10 μ m in particle diameter).

Column temperature: A constant temperature of about 25°C.

Mobile phase: A solution of ammonium sulfate (1 in 800).

Flow rate: Adjust so that the retention time of ammonium aminotrichloroplatinate is about 8 minutes.

System suitability—

System performance: When the procedure is run with 40 μ L of the standard solution under the above operating conditions, the number of theoretical plates and the symmetry factor of the peak of ammonium aminotrichloroplatinate are not less than 1500 and not more than 2.0, respectively.

System repeatability: When the test is repeated 6 times with 40 μ L of the standard solution under the above operating conditions, the relative standard deviation of the peak area of ammonium aminotrichloroplatinate is not more than 3.0%.

Loss on drying <2.41> Not more than 0.1% (1 g, 105°C, 4 hours).

Assay Conduct this procedure using light-resistant vessels. Weigh accurately about 25 mg each of Cisplatin and Cisplatin RS, previously dried, dissolve in *N,N*-dimethylformamide to make exactly 25 mL, and use these solutions as the sample solution and standard solution. Perform the test with exactly 40 μ L each of the sample solution and standard solution as directed under Liquid Chromatography <2.01> according to the following conditions, and determine the peak areas, A_T and A_S , of cisplatin in each solution.

$$\text{Amount (mg) of cisplatin } (\text{Cl}_2\text{H}_6\text{N}_2\text{Pt}) = M_S \times A_T / A_S$$

M_3 : Amount (mg) of Cisplatin RS taken

Operating conditions—

Detector: An ultraviolet absorption photometer (wavelength: 310 nm).

Column: A stainless steel column 4.6 mm in inside diameter and 25 cm in length, packed with aminopropylsilylated silica gel for liquid chromatography (5 μ m in particle diameter).

Column temperature: A constant temperature of about 25°C.

Mobile phase: A mixture of ethyl acetate, methanol, water and *N,N*-dimethylformamide (25:16:5:5).

Flow rate: Adjust so that the retention time of cisplatin is about 4 minutes.

System suitability—

System performance: When the procedure is run with 40 μ L of the standard solution under the above operating conditions, the number of theoretical plates and the symmetry factor of the peak of cisplatin are not less than 3000 and not more than 2.0, respectively.

System repeatability: When the test is repeated 6 times with 40 μ L of the standard solution under the above operating conditions, the relative standard deviation of the peak area of cisplatin is not more than 1.0%.

Containers and storage Containers—Tight containers.

Citicoline

シチコリン

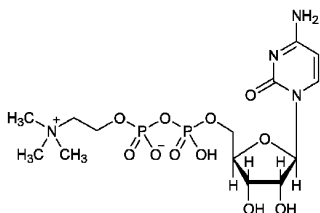

$C_{14}H_{26}N_4O_{11}P_2$: 488.32

P'-[2-(Trimethylammonio)ethyl] cytidine
5'-(monohydrogen diphosphate)
[987-78-0]

Citicoline contains not less than 98.0% and not more than 102.0% of citicoline ($C_{14}H_{26}N_4O_{11}P_2$), calculated on the dried basis.

Description Citicoline occurs as a white crystalline powder.

It is very soluble in water, and practically insoluble in ethanol (99.5).

It dissolves in 0.01 mol/L hydrochloric acid TS.

Identification (1) Determine the absorption spectrum of a solution of Citicoline in 0.01 mol/L hydrochloric acid TS (3 in 200,000) as directed under Ultraviolet-visible Spectrophotometry <2.24>, and compare the spectrum with the Reference Spectrum or the spectrum of a solution of Citicoline RS prepared in the same manner as the sample solution: both spectra exhibit similar intensities of absorption at the same wavelengths.

(2) Determine the infrared absorption spectrum of Citicoline as directed in the potassium bromide disk method under Infrared Spectrophotometry <2.25>, and compare the spectrum with the Reference Spectrum or the spectrum of Citicoline RS: both spectra exhibit similar intensities of absorption at the same wave numbers.

pH <2.54> The pH of a solution obtained by dissolving 1.0 g of Citicoline in 100 mL of water is between 2.5 and 3.5.

Purity (1) Clarity and color of solution—Dissolve 1.0 g of Citicoline in 8 mL of water: the solution is clear and colorless.

(2) Heavy metals <1.07>—Proceed with 2.0 g of Citicoline according to Method 1, and perform the test. Prepare the control solution with 2.0 mL of Standard Lead Solution (not more than 10 ppm).

(3) Arsenic <1.11>—Prepare the test solution with 1.0 g of Citicoline according to Method 4, and perform the test (not more than 2 ppm).

(4) Free phosphoric acid—Weigh accurately about 0.1 g of Citicoline, dissolve in water to make exactly 10 mL, and use this solution as the sample solution. Separately, pipet 4 mL of Standard Phosphoric Acid Solution, add water to make exactly 10 mL, and use this solution as the standard solution. To each of the sample solution and the standard solution, add exactly 1 mL of hexaammonium heptamolybdate-sulfuric acid TS and exactly 0.5 mL of 1-amino-2-naphthol-4-sulfonic acid TS, and after shaking, allow to stand for 30 minutes at $20 \pm 1^\circ\text{C}$. To exactly 2 mL each of these solutions add water to make exactly 10 mL, and determine the absorbances, A_T and A_S , of the solutions obtained from the sample solution and the standard solution at 730 nm as directed under Ultraviolet-visible Spectrometry <2.24>, using the solution, obtained by proceeding with 10 mL of water in the same manner as the sample solution, as the blank. The amount of free phosphoric acid is not more than 0.1%.

$$\begin{aligned} \text{Amount (\%)} \text{ of free phosphoric acid (H}_3\text{PO}_4) \\ = 1/M \times A_T/A_S \times 10.32 \end{aligned}$$

M : Amount (mg) of Citicoline taken, calculated on the dried basis

(5) Related substances—Dissolve 0.10 g of Citicoline in water to make 100 mL, and use this solution as the sample solution. Pipet 1 mL of the sample solution, add water to make exactly 200 mL, and use this solution as the standard solution. Perform the test with exactly 10 μ L each of the sample solution and standard solution as directed under Liquid Chromatography <2.01> according to the following conditions, and determine each peak area by the automatic integration method: the area of the peaks other than citicoline obtained from the sample solution is not larger than 3/5 times the peak area of citicolins from the standard solution, and the total area of the peaks other than citicoline from the sample solution is not larger than the peak area of citicoline from the standard solution. For the area of the peaks, having the relative retention times of about 0.62, about 0.64 and about 1.3 to citicoline, multiply the correction factors, 1.2, 0.7 and 0.5, respectively.

Operating conditions—

Detector, column, column temperature, mobile phase, and flow rate: Proceed as directed in the operating conditions in the Assay.

Time span of measurement: About 2 times as long as the retention time of citicoline.

System suitability—

Test for required detectability: Pipet 4 mL of the standard solution, and add water to make exactly 50 mL. Confirm that the peak area of citicoline obtained with 10 μ L of this solution is equivalent to 5.6 to 10.4% of that with 10 μ L of the standard solution.

System performance: When the procedure is run with 10 μ L of the standard solution under the above operating con-

ditions, the number of theoretical plates and the symmetry factor of the peak of citicoline are not less than 2000 and 0.9 to 1.6, respectively.

System repeatability: When the test is repeated 6 times with 10 μ L of the standard solution under the above operating conditions, the relative standard deviation of the peak area of citicoline is not more than 2.0%.

Loss on drying <2.41> Not more than 5.0% (1 g, in vacuum, phosphorus (V) oxide, 100°C, 4 hours).

Assay Weigh accurately about 0.1 g of Citicoline, and dissolve in water to make exactly 100 mL. Pipet 1 mL of this solution, add water to make exactly 100 mL, and use this solution as the sample solution. Separately, weigh accurately about 25 mg of Citicoline RS (separately determine the loss on drying <2.41> under the same conditions as Citicoline), and dissolve in water to make exactly 25 mL. Pipet 1 mL of this solution, add water to make exactly 100 mL, and use this solution as the standard solution. Perform the test with exactly 10 μ L each of the sample solution and standard solution as directed under Liquid Chromatography <2.01> according to the following conditions, and determine the peak areas, A_T and A_S , of citicoline in each solution.

$$\begin{aligned} \text{Amount (mg) of citicoline (C}_{14}\text{H}_{26}\text{N}_4\text{O}_{11}\text{P}_2) \\ = M_S \times A_T/A_S \times 4 \end{aligned}$$

M_S : Amount (mg) of Citicoline RS taken, calculated on the dried basis

Operating conditions—

Detector: An ultraviolet absorption photometer (wavelength: 254 nm).

Column: Combine 2 stainless steel columns (4 mm in inside diameter and 25 cm in length) packed with strongly basic ion exchange resin for liquid chromatography (10 μ m in particle diameter) in series.

Column temperature: A constant temperature of about 30°C.

Mobile phase: Dissolve 8.17 g of potassium dihydrogen phosphate in water to make 1000 mL. Adjust the pH of this solution to 3.5 with phosphoric acid.

Flow rate: Adjust so that the retention time of citicoline is about 26 minutes.

System suitability—

System performance: When the procedure is run with 10 μ L of the standard solution under the above operating conditions, the number of theoretical plates and the symmetry factor of the peak of citicoline are not less than 2000 and 0.9 to 1.6, respectively.

System repeatability: When the test is repeated 6 times with 10 μ L of the standard solution under the above operating conditions, the relative standard deviation of the peak area of citicoline is not more than 1.0%.

Containers and storage Containers—Tight containers.

Anhydrous Citric Acid

無水クエン酸

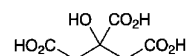

$C_6H_8O_7$: 192.12

2-Hydroxypropane-1,2,3-tricarboxylic acid
[77-92-9]

This monograph is harmonized with the European Pharmacopoeia and the U.S. Pharmacopoeia.

The parts of the text that are not harmonized are marked with symbol \blacklozenge .

Information on the harmonization with the European Pharmacopoeia and the U.S. Pharmacopoeia is available on the website of the Pharmaceuticals and Medical Devices Agency.

Anhydrous Citric Acid contains not less than 99.5% and not more than 100.5% of anhydrous citric acid ($C_6H_8O_7$), calculated on the anhydrous basis.

Description Anhydrous Citric Acid occurs as colorless crystals, white granules or crystalline powder.

It is very soluble in water, and freely soluble in ethanol (99.5%). \blacklozenge

Identification Determine the infrared absorption spectrum of Anhydrous Citric Acid, previously dried at 105°C for 2 hours, as directed in the potassium bromide disk method under Infrared Spectrophotometry <2.25>, and compare the spectrum with the Reference Spectrum: both spectra exhibit similar intensities of absorption at the same wave numbers.

Purity (1) Clarity and color of solution—Dissolve 2.0 g of Anhydrous Citric Acid in water to make 10 mL: the solution is clear and colorless or has no more color than the following control solutions (1), (2) or (3).

Control solution (1): To 1.5 mL of Cobalt (II) Chloride CS and 6.0 mL of Iron (III) Chloride CS add diluted dilute hydrochloric acid (1 in 10) to make 1000 mL.

Control solution (2): To 2.5 mL of Cobalt (II) Chloride CS, 6.0 mL of Iron (III) Chloride CS and 1.0 mL of Copper (II) Sulfate CS add diluted dilute hydrochloric acid (1 in 10) to make 1000 mL.

Control solution (3): To 0.15 mL of Cobalt (II) Chloride CS, 7.2 mL of Iron (III) Chloride CS and 0.15 mL of Copper (II) Sulfate CS add diluted dilute hydrochloric acid (1 in 10) to make 1000 mL.

(2) Sulfates—Dissolve 2.0 g of Anhydrous Citric Acid in water to make 30 mL, and use this solution as the sample solution. Separately, dissolve 0.181 g of potassium sulfate in diluted ethanol (3 in 10) to make exactly 500 mL. Pipet 5 mL of this solution, and add diluted ethanol (3 in 10) to make exactly 100 mL. To 4.5 mL of this solution add 3 mL of a solution of barium chloride dihydrate (1 in 4), shake, and allow to stand for 1 minute. To 2.5 mL of this solution add 15 mL of the sample solution and 0.5 mL of acetic acid (31), and allow to stand for 5 minutes: the solution has no more turbidity than the following control solution (not more than 150 ppm).

Control solution: Dissolve 0.181 g of potassium sulfate in water to make exactly 500 mL. Pipet 5 mL of this solution, add water to make exactly 100 mL, and proceed in the same manner as above using this solution instead of the sample solution.

(3) Oxalic acid—Dissolve 0.80 g of Anhydrous Citric Acid in 4 mL of water, add 3 mL of hydrochloric acid and 1 g of zinc, and boil for 1 minute. After allowing to stand for 2 minutes, take the supernatant liquid, add 0.25 mL of a solution of phenylhydrazinium chloride (1 in 100), heat to boil, and then cool quickly. To this solution add the equal volume of hydrochloric acid and 0.25 mL of a solution of potassium hexacyanoferrate (III) (1 in 20), mix, and allow to stand for 30 minutes: the solution has no more color than the following control solution prepared at the same time (not more than 360 ppm expressed as oxalic anhydride).

Control solution: To 4 mL of a solution of oxalic acid dihydrate (1 in 10,000) add 3 mL of hydrochloric acid and 1 g of zinc, and proceed in the same manner as the test solution.

◆(4) Heavy metals <1.07>—Proceed with 2.0 g of Anhydrous Citric Acid according to Method 2, and perform the test. Prepare the control solution with 2.0 mL of Standard Lead Solution (not more than 10 ppm).◆

(5) Readily carbonizable substances—Place 1.0 g of Anhydrous Citric Acid in a Nessler tube, add 10 mL of sulfuric acid, immediately heat in a $90 \pm 1^\circ\text{C}$ water bath for 60 minutes, and cool quickly. Compare the color of 2.0 mL each of this solution and Matching Fluid K, using test tubes 12 mm in outside diameter, from a side against white background: the solution is not more colored than the matching fluid.

Water <2.48> Not more than 1.0% (2 g, volumetric titration, direct titration).

Residue on ignition <2.44> Not more than 0.1% (1 g).

Assay Weigh accurately about 0.55 g of Anhydrous Citric Acid, dissolve in 50 mL of water, and titrate with 1 mol/L sodium hydroxide VS (indicator: 1 drop of phenolphthalein TS).

Each mL of 1 mol/L sodium hydroxide VS
= 64.04 mg of $\text{C}_6\text{H}_8\text{O}_7$

◆**Containers and storage** Containers—Tight containers.◆

Citric Acid Hydrate

クエン酸水和物

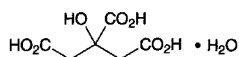

$\text{C}_6\text{H}_8\text{O}_7 \cdot \text{H}_2\text{O}$: 210.14

2-Hydroxypropane-1,2,3-tricarboxylic acid monohydrate
[5949-29-1]

This monograph is harmonized with the European Pharmacopoeia and the U.S. Pharmacopoeia.

The parts of the text that are not harmonized are marked with symbol (◆ ◆).

Information on the harmonization with the European Pharmacopoeia and the U.S. Pharmacopoeia is available on the website of the Pharmaceuticals and Medical Devices Agency.

Citric Acid Hydrate contains not less than 99.5% and not more than 100.5% of anhydrous citric acid ($\text{C}_6\text{H}_8\text{O}_7$: 192.12), calculated on the anhydrous basis.

◆**Description** Citric Acid Hydrate occurs as colorless crystals, white granules or crystalline powder.

It is very soluble in water, and freely soluble in ethanol (99.5).

It is efflorescent in dry air.◆

Identification Determine the infrared absorption spectrum of Citric Acid Hydrate, previously dried at 105°C for 2 hours, as directed in the potassium bromide disk method under Infrared Spectrophotometry <2.25>, and compare the spectrum with the Reference Spectrum: both spectra exhibit similar intensities of absorption at the same wave numbers.

Purity (1) Clarity and color of solution—Dissolve 2.0 g of Citric Acid Hydrate in water to make 10 mL: the solution is clear and colorless or has no more color than the following control solutions (1), (2) or (3).

Control solution (1): To 1.5 mL of Cobalt (II) Chloride CS and 6.0 mL of Iron (III) Chloride CS add diluted dilute hydrochloric acid (1 in 10) to make 1000 mL.

Control solution (2): To 2.5 mL of Cobalt (II) Chloride CS, 6.0 mL of Iron (III) Chloride CS and 1.0 mL of Copper (II) Sulfate CS add diluted dilute hydrochloric acid (1 in 10) to make 1000 mL.

Control solution (3): To 0.15 mL of Cobalt (II) Chloride CS, 7.2 mL of Iron (III) Chloride CS and 0.15 mL of Copper (II) Sulfate CS add diluted dilute hydrochloric acid (1 in 10) to make 1000 mL.

(2) Sulfates—Dissolve 2.0 g of Citric Acid Hydrate in water to make 30 mL, and use this solution as the sample solution. Separately, dissolve 0.181 g of potassium sulfate in diluted ethanol (3 in 10) to make exactly 500 mL. Pipet 5 mL of this solution, and add diluted ethanol (3 in 10) to make exactly 100 mL. To 4.5 mL of this solution add 3 mL of a solution of barium chloride dihydrate (1 in 4), shake, and allow to stand for 1 minute. To 2.5 mL of this solution add 15 mL of the sample solution and 0.5 mL of acetic acid (31), and allow to stand for 5 minutes: the solution has no more turbidity than the following control solution. (not more than 150 ppm).

Control solution: Dissolve 0.181 g of potassium sulfate in water to make exactly 500 mL. Pipet 5 mL of this solution, add water to make exactly 100 mL, and proceed in the same manner as above using this solution instead of the sample solution.

(3) Oxalic acid—Dissolve 0.80 g of Citric Acid Hydrate in 4 mL of water, add 3 mL of hydrochloric acid and 1 g of zinc, and boil for 1 minute. After allowing to stand for 2 minutes, take the supernatant liquid, add 0.25 mL of a solution of phenylhydrazinium chloride (1 in 100), heat to boil, and then cool quickly. To this solution add the equal volume of hydrochloric acid and 0.25 mL of a solution of potassium hexacyanoferrate (III) (1 in 20), mix, and allow to stand for 30 minutes: the solution has no more color than the following control solution prepared at the same time (not more than 360 ppm expressed as oxalic anhydride).

Control solution: To 4 mL of a solution of oxalic acid dihydrate (1 in 10,000) add 3 mL of hydrochloric acid and 1 g of zinc, and proceed in the same manner as the test solution.

◆(4) Heavy metals <1.07>—Proceed with 2.0 g of Citric Acid Hydrate according to Method 2, and perform the test. Prepare the control solution with 2.0 mL of Standard Lead Solution (not more than 10 ppm).◆

(5) Readily carbonizable substances—Place 1.0 g of Citric Acid Hydrate in a Nessler tube, add 10 mL of sulfuric acid, immediately heat in a $90 \pm 1^\circ\text{C}$ water bath for 60 minutes, and cool quickly. Compare the color of 2.0 mL each of this solution and Matching Fluid K, using test tubes 12 mm in outside diameter, from a side against white background: the solution is not more colored than the matching fluid.

Water <2.48> Not less than 7.5% and not more than 9.0% (0.5 g, volumetric titration, direct titration).

Residue on ignition <2.44> Not more than 0.1% (1 g).

Assay Weigh accurately about 0.55 g of Citric Acid Hydrate, dissolve in 50 mL of water, and titrate <2.50> with 1 mol/L sodium hydroxide VS (indicator: 1 drop of phenolphthalein TS).

Each mL of 1 mol/L sodium hydroxide VS
= 64.04 mg of C₃₈H₆₉O₇

◆**Containers and storage** Containers—Tight containers.◆

Clarithromycin

クラリスロマイシン

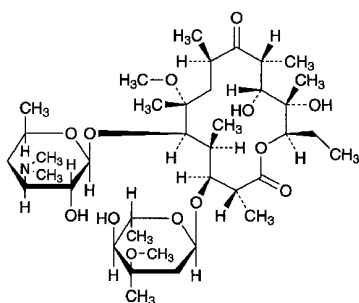

C₃₈H₆₉NO₁₃; 747.95
(2*R*,3*S*,4*S*,5*R*,6*R*,8*R*,10*R*,11*R*,12*S*,13*R*)-5-(3,4,6-Trideoxy-3-dimethylamino-β-D-xylo-hexopyranosyloxy)-3-(2,6-dideoxy-3-C-methyl-3-O-methyl-α-L-ribo-hexopyranosyloxy)-11,12-dihydroxy-6-methoxy-2,4,6,8,10,12-hexamethyl-9-oxopentadecan-13-olide [81103-11-9]

Clarithromycin is a derivative of erythromycin.

It contains not less than 950 μg (potency) and not more than 1050 μg (potency) per mg, calculated on the anhydrous basis. The potency of Clarithromycin is expressed as mass (potency) of clarithromycin (C₃₈H₆₉NO₁₃).

Description Clarithromycin occurs as a white crystalline powder and has a bitter taste.

It is soluble in acetone and in chloroform, slightly soluble in methanol and in ethanol (95), and practically insoluble in water.

Identification (1) To 5 mg of Clarithromycin add 2 mL of sulfuric acid, and shake gently: a red-brown color develops.

(2) Dissolve 3 mg of Clarithromycin in 2 mL of acetone, and add 2 mL of hydrochloric acid: an orange color develops and changes immediately to red to deep purple.

(3) Determine the infrared absorption spectra of Clarithromycin and Clarithromycin RS as directed in the potassium bromide disk method under Infrared Spectrophotometry <2.25>, and compare these spectra: both spectra exhibit similar intensities of absorption at the same wave numbers.

Optical rotation <2.49> [α]_D²⁰: −96 – −106° (0.25 g calculated on the anhydrous basis, acetone, 25 mL, 100 mm).

Melting point <2.60> 220 – 227°C

Purity (1) Heavy metals <1.07>—Proceed with 2.0 g of Clarithromycin according to Method 4, and perform the

test. Prepare the control solution with 2.0 mL of Standard Lead Solution (not more than 10 ppm).

(2) Related substances—Weigh accurately about 0.1 g of Clarithromycin, dissolve in the mobile phase to make exactly 20 mL, and use this solution as the sample solution. Separately, weigh accurately about 10 mg of Clarithromycin RS, dissolve in the mobile phase to make exactly 20 mL, and use this solution as the standard solution. Perform the test with exactly 10 μL each of the sample solution and standard solution as directed under Liquid Chromatography <2.01> according to the following conditions, and determine the each peak area by the automatic integration method: the amount of each related substance calculated on the anhydrous basis is not more than 2.0%, and the total amount of them is not more than 5.0%. For these calculations, exclude any peak with an area of less than 0.05%.

Amount (%) of each related substance calculated on the anhydrous basis
= $M_S/M_T \times A_T/A_S \times 100$

Total amount (%) of the related substances calculated on the anhydrous basis
= $M_S/M_T \times \Sigma A_T/A_S \times 100$

M_S : Amount (mg) of Clarithromycin RS taken

M_T : Amount (mg) of Clarithromycin taken, calculated on the anhydrous basis

A_S : Peak area of clarithromycin obtained with the standard solution

A_T : Peak area of each related substance obtained with the sample solution

ΣA_T : Total area of the peaks other than clarithromycin obtained with the sample solution

Operating conditions—

Detector, column, column temperature, mobile phase, and flow rate: Proceed as directed in the operating conditions in the Assay.

Time span of measurement: About 5 times as long as the retention time of the main peak, beginning from 2 minutes after injection of the sample solution.

System suitability—

Test for required detectability: To exactly 2 mL of the standard solution add the mobile phase to make exactly 10 mL, and use this solution as the solution for system suitability test. Pipet 1 mL of the solution for system suitability test, add the mobile phase to make exactly 10 mL. Pipet 2.5 mL of this solution, add the mobile phase to make exactly 10 mL. Confirm that the peak area of clarithromycin obtained with 10 μL of this solution is equivalent to 0.25 – 0.75% of that with 10 μL of the standard solution.

System performance: When the procedure is run with 10 μL of the solution for system suitability test under the above operating conditions, the number of theoretical plates and the symmetry factor of the peak of clarithromycin are not less than 2500 and not more than 2.5, respectively.

System repeatability: When the test is repeated 6 times with 10 μL of the solution for system suitability test under the above operating conditions, the relative standard deviation of the peak area of clarithromycin is not more than 3.0%.

Water <2.48> Not more than 2.0% (0.5 g, volumetric titration, direct titration).

Residue on ignition <2.44> Not more than 0.1% (2 g).

Assay Weigh accurately an amount of Clarithromycin and Clarithromycin RS, equivalent to about 50 mg (potency),

and dissolve each in the mobile phase to make exactly 10 mL. Pipet 2 mL each of these solutions, add exactly 2 mL of the internal standard solution, add the mobile phase to make 20 mL, and use these solutions as the sample solution and the standard solution. Perform the test with 10 μ L each of the sample solution and standard solution as directed under Liquid Chromatography <2.01> according to the following conditions, and calculate the ratios, Q_T and Q_S , of the peak area of clarithromycin to that of the internal standard.

$$\begin{aligned} \text{Amount } [\mu\text{g (potency)}] \text{ of clarithromycin (C}_{38}\text{H}_{69}\text{NO}_{13}) \\ = M_S \times Q_T/Q_S \times 1000 \end{aligned}$$

M_S : Amount [mg (potency)] of Clarithromycin RS taken

Internal standard solution—A solution of butyl parahydroxybenzoate in the mobile phase (1 in 20,000).

Operating conditions—

Detector: An ultraviolet absorption photometer (wavelength: 210 nm).

Column: A stainless steel column 4 mm in inside diameter and 15 cm in length, packed with octadecylsilylated silica gel for liquid chromatography (5 μ m in particle diameter).

Column temperature: A constant temperature of about 50°C.

Mobile phase: A mixture of diluted 0.2 mol/L potassium dihydrogen phosphate TS (1 in 3) and acetonitrile (13:7).

Flow rate: Adjust so that the retention time of clarithromycin is about 8 minutes.

System suitability—

System performance: When the procedure is run with 10 μ L of the standard solution under the above operating conditions, clarithromycin and the internal standard are eluted in this order with the resolution between these peaks being not less than 3.

System repeatability: When the test is repeated 6 times with 10 μ L of the standard solution under the above operating conditions, the relative standard deviation of the ratios of the peak area of clarithromycin to that of the internal standard is not more than 2.0%.

Containers and storage Containers—Well-closed containers.

Clarithromycin for Syrup

シロップ用クラリスロマイシン

Clarithromycin for Syrup is a preparation for syrup, which is suspended before use.

It contains not less than 90.0% and not more than 110.0% of the labeled potency of clarithromycin (C₃₈H₆₉NO₁₃: 747.95).

Method of preparation Prepare as directed under Preparations for Syrups, with Clarithromycin.

Identification To an amount of Clarithromycin for Syrup, equivalent to 0.1 g (potency) of Clarithromycin, add 5 mL of acetone, and sonicate. After cooling with ice, centrifuge, take the supernatant liquid, and evaporate the solvent. Dissolve 10 mg of the residue and 2 mg of Clarithromycin RS in separate 2 mL of acetone, and use these solutions as the sample solution and the standard solution, respectively. Perform the test with these solutions as directed under Thin-layer Chromatography <2.03>. Spot 10 μ L each of the sample solution and standard solution on a plate of silica gel for thin-layer chromatography. Develop the plate with a mixture of

methanol, ethyl acetate and acetic acid (100) (90:10:1) to a distance of about 15 cm, and air-dry the plate. Spray evenly sulfuric acid on the plate, and heat the plate at 105°C for 10 minutes: the principal spot obtained from the sample solution and the spot from the standard solution show a black-purple color and the same R_f value.

Water <2.48> Not more than 3.0% (0.5 g, volumetric titration, direct titration).

Uniformity of dosage units <6.02> Perform the test according to the following method: Clarithromycin for Syrup in single-dose packages meet the requirement of the Content uniformity test.

To the total content of 1 package of Clarithromycin for Syrup add 3V/5 mL of ethanol (99.5), add exactly V/10 mL of the internal standard solution, sonicate with occasional vigorous shaking, and add ethanol (99.5) to make V mL so that each mL contains about 0.5 mg (potency) of Clarithromycin. Centrifuge this solution, and filter the supernatant liquid through a membrane filter with a pore size not exceeding 0.45 μ m. Discard the first 3 mL of the filtrate, and use the subsequent filtrate as the sample solution. Then, proceed as directed in the Assay.

$$\begin{aligned} \text{Amount [mg (potency)] of clarithromycin (C}_{38}\text{H}_{69}\text{NO}_{13}) \\ = M_S \times Q_T/Q_S \times V/100 \end{aligned}$$

M_S : Amount [mg (potency)] of Clarithromycin RS taken

Internal standard solution—A solution of butyl parahydroxybenzoate in ethanol (99.5) (1 in 12,500).

Dissolution <6.10> When the test is performed at 50 revolutions per minute according to the Paddle method, using 900 mL of disodium hydrogen phosphate-citric acid buffer solution (pH 5.5) as the dissolution medium, the dissolution rate in 90 minutes of Clarithromycin for Syrup is not less than 75%.

Start the test with an accurately weighed amount of Clarithromycin for Syrup, equivalent to about 50 mg (potency) of Clarithromycin, withdraw not less than 20 mL of the medium at the specified minute after starting the test, and filter through a membrane filter with a pore size not exceeding 0.45 μ m. Discard not less than 10 mL of the first filtrate, pipet 10 mL of the subsequent filtrate, add the mobile phase to make exactly 20 mL, and use this solution as the sample solution. Separately, weigh accurately an amount of Clarithromycin RS, equivalent to about 28 mg (potency), and dissolve in acetonitrile for liquid chromatography to make exactly 100 mL. Pipet 5 mL of this solution, add the mobile phase to make exactly 50 mL, and use this solution as the standard solution. Perform the test with exactly 100 μ L each of the sample solution and standard solution as directed under Liquid Chromatography <2.01> according to the following conditions, and determine the peak areas, A_T and A_S , of clarithromycin in each solution.

$$\begin{aligned} \text{Dissolution rate (\%)} \text{ with respect to the labeled amount} \\ \text{of clarithromycin (C}_{38}\text{H}_{69}\text{NO}_{13}) \\ = M_S/M_T \times A_T/A_S \times 1/C \times 180 \end{aligned}$$

M_S : Amount [mg (potency)] of Clarithromycin RS taken

M_T : Amount (g) of Clarithromycin for Syrup taken

C : Labeled amount of [mg (potency)] of clarithromycin (C₃₈H₆₉NO₁₃) in 1 g

Operating conditions—

Proceed as directed in the operating conditions in the Assay.

System suitability—

System performance: When the procedure is run with 100 μL of the standard solution under the above operating conditions, the number of theoretical plates and the symmetry factor of the peak of clarithromycin are not less than 3000 and not more than 2.0, respectively.

System repeatability: When the test is repeated 6 times with 100 μL of the standard solution under the above operating conditions, the relative standard deviation of the peak area of clarithromycin is not more than 2.0%.

Assay Weigh accurately an amount of crushed Clarithromycin for Syrup, equivalent to about 50 mg (potency) of Clarithromycin, add 60 mL of ethanol (99.5), add exactly 10 mL of the internal standard solution, sonicate with occasional vigorous shaking, and add ethanol (99.5) to make 100 mL. Centrifuge this solution, and filter the supernatant liquid through a membrane filter with a pore size not exceeding 0.45 μm . Discard the first 3 mL of the filtrate, and use the subsequent filtrate as the sample solution. Separately, weigh accurately an amount of Clarithromycin RS, equivalent about 50 mg (potency), and dissolve in ethanol (99.5) to make exactly 50 mL. Pipet 10 mL of this solution, add exactly 2 mL of the internal standard solution, add ethanol (99.5) to make 20 mL, and use this solution as the standard solution. Perform the test with 10 μL each of the sample solution and standard solution as directed under Liquid Chromatography <2.01> according to the following conditions, and calculate the ratios, Q_T and Q_S , of the peak area of clarithromycin to that of the internal standard.

$$\begin{aligned} \text{Amount [mg (potency)] of clarithromycin (C}_{38}\text{H}_{69}\text{NO}_{13}) \\ = M_S \times Q_T/Q_S \end{aligned}$$

M_S : Amount [mg (potency)] of Clarithromycin RS taken

Internal standard solution—A solution of butyl parahydroxybenzoate in ethanol (99.5) (1 in 12,500).

Operating conditions—

Detector: An ultraviolet absorption photometer (wavelength: 210 nm).

Column: A stainless steel column 4.6 mm in inside diameter and 15 cm in length, packed with octadecylsilanized silica gel for liquid chromatography (5 μm in particle diameter).

Column temperature: A constant temperature of about 50°C.

Mobile phase: A mixture of diluted 0.2 mol/L potassium dihydrogen phosphate TS (1 in 3) and acetonitrile for liquid chromatography (13:7).

Flow rate: Adjust so that the retention time of clarithromycin is about 8 minutes.

System suitability—

System performance: When the procedure is run with 10 μL of the standard solution under the above operating conditions, clarithromycin and the internal standard are eluted in this order with the resolution between these peaks being not less than 3.

System repeatability: When the test is repeated 6 times with 10 μL of the standard solution under the above operating conditions, the relative standard deviation of the ratio of the peak area of clarithromycin to that of the internal standard is not more than 2.0%.

Containers and storage Containers—Tight containers.

Storage—Light-resistant.

Clarithromycin Tablets

クラリスロマイシン錠

Clarithromycin Tablets contain not less than 93.0% and not more than 107.0% of the labeled potency of clarithromycin (C₃₈H₆₉NO₁₃: 747.95).

Method of preparation Prepare as directed under Tablets, with Clarithromycin.

Identification Shake a quantity of powdered Clarithromycin Tablets, equivalent to 60 mg (potency) of Clarithromycin, with 40 mL of acetone for 10 minutes, and centrifuge at 4000 rpm for 5 minutes. Evaporate 30 mL of the supernatant liquid, and determine the infrared absorption spectrum of the residue so obtained as directed in the potassium bromide disk method under Infrared Spectrophotometry <2.25>: it exhibits absorption at the wave numbers of about 2980 cm⁻¹, 2940 cm⁻¹, 1734 cm⁻¹, 1693 cm⁻¹, 1459 cm⁻¹, 1379 cm⁻¹ and 1171 cm⁻¹.

Uniformity of dosage units <6.02> Perform the Mass variation test, or the Content uniformity test according to the following method: it meets the requirement.

To 1 tablet of Clarithromycin Tablets add exactly $V/20$ mL of the internal standard solution (1), then add the mobile phase so that each mL contains about 5 mg (potency) of clarithromycin (C₃₈H₆₉NO₁₃) to make V mL, and disperse to fine particles by sonicating for 20 minutes while occasional vigorous shaking. Centrifuge this solution at 4000 rpm for 15 minutes, and filter the supernatant liquid through a membrane filter with a pore size not exceeding 0.45 μm . Then, proceed as directed in the Assay.

$$\begin{aligned} \text{Amount [mg (potency)] of clarithromycin (C}_{38}\text{H}_{69}\text{NO}_{13}) \\ = M_S \times Q_T/Q_S \times V/10 \end{aligned}$$

M_S : Amount [mg (potency)] of Clarithromycin RS taken

Internal standard solution (1)—A solution of butyl parahydroxybenzoate in the mobile phase (1 in 1000).

Internal standard solution (2)—To exactly 1 mL of the internal standard solution (1) add the mobile phase to make exactly 20 mL.

Dissolution <6.10> When the test is performed at 50 revolutions per minute according to the Paddle method, using 900 mL of 0.05 mol/L disodium hydrogen phosphate-citric acid buffer solution (pH 6.0) as the dissolution medium, the dissolution rates in 30 minutes of a 50-mg tablet and a 200-mg tablet are not less than 80% and not less than 75%, respectively.

Start the test with 1 tablet of Clarithromycin Tablets, withdraw not less than 20 mL of the medium at the specified minute after starting the test, and filter through a membrane filter with a pore size not exceeding 0.45 μm . Discard not less than 10 mL of the first filtrate, pipet V mL of the subsequent filtrate, add the mobile phase to make exactly V' mL so that each mL contains about 28 μg (potency) of Clarithromycin, and use this solution as the sample solution. Separately, weigh accurately an amount of Clarithromycin RS, equivalent to about 28 mg (potency), and dissolve in acetonitrile for liquid chromatography to make exactly 100 mL. Pipet 5 mL of this solution, add the mobile phase to make exactly 50 mL, and use this solution as the standard solution. Perform the test with exactly 100 μL each of the sample solution and standard solution as directed under Liquid Chromatography <2.01> according to the following conditions, and determine

the peak areas, A_T and A_S , of clarithromycin in each solution.

Dissolution rate (%) with respect to the labeled amount of clarithromycin ($C_{38}H_{69}NO_{13}$)

$$= M_S \times A_T/A_S \times V'/V \times 1/C \times 90$$

M_S : Amount [mg (potency)] of Clarithromycin RS taken
 C : Labeled amount [mg (potency)] of clarithromycin ($C_{38}H_{69}NO_{13}$) in 1 tablet

Operating conditions—

Proceed as directed in the operating conditions in the Assay.

System suitability—

System performance: When the procedure is run with 100 μ L of the standard solution under the above operating conditions, the number of theoretical plates and the symmetry factor of the peak of clarithromycin are not less than 3000 and not more than 2.0, respectively.

System repeatability: When the test is repeated 6 times with 100 μ L of the standard solution under the above operating conditions, the relative standard deviation of the peak area of clarithromycin is not more than 2.0%.

Assay To not less than 5 Clarithromycin Tablets add diluted 0.2 mol/L potassium dihydrogen phosphate TS (1 in 3) so that each mL contains about 8 mg (potency) of clarithromycin ($C_{38}H_{69}NO_{13}$), disperse to fine particles by sonicating, add exactly 1 mL of the internal standard solution (1) per 100 mg (potency) of clarithromycin, then add acetonitrile for liquid chromatography so that each mL contains about 5 mg (potency) of clarithromycin ($C_{38}H_{69}NO_{13}$), and disperse to fine particles by sonicating for 10 minutes while occasional vigorous shaking. Centrifuge of this solution at 4000 rpm for 15 minutes, and filter the supernatant liquid through a membrane filter with a pore size not exceeding 0.45 μ m. Discard the first 3 mL of the filtrate, to 2 mL of the subsequent filtrate add the mobile phase to make 20 mL, and use this solution as the sample solution. Separately, weigh accurately an amount of Clarithromycin RS, equivalent to about 50 mg (potency), and dissolve in the mobile phase to make exactly 10 mL. Pipet 2 mL of this solution, add exactly 2 mL of the internal standard solution (2) and the mobile phase to make 20 mL, and use this solution as the standard solution. Perform the test with 10 μ L each of the sample solution and standard solution as directed under Liquid Chromatography <2.01> according to the following conditions, and calculate the ratios, Q_T and Q_S , of the peak area of clarithromycin to that of the internal standard.

Amount [mg (potency)] of clarithromycin ($C_{38}H_{69}NO_{13}$)

$$= M_S \times Q_T/Q_S \times 1/5$$

M_S : Amount [mg (potency)] of Clarithromycin RS taken

Internal standard solution (1)—A solution of butyl parahydroxybenzoate in the mobile phase (1 in 1000).

Internal standard solution (2)—To exactly 1 mL of the internal standard solution (1) add the mobile phase to make exactly 20 mL.

Operating conditions—

Detector: An ultraviolet absorption photometer (wavelength: 210 nm).

Column: A stainless steel column 4.6 mm in inside diameter and 15 cm in length, packed with octadecylsilanized silica gel for liquid chromatography (5 μ m in particle diameter).

Column temperature: A constant temperature of about 50°C.

Mobile phase: A mixture of diluted 0.2 mol/L potassium

dihydrogen phosphate TS (1 in 3) and acetonitrile for liquid chromatography (13:7).

Flow rate: Adjust so that the retention time of clarithromycin is about 8 minutes.

System suitability—

System performance: When the procedure is run with 10 μ L of the standard solution under the above operating conditions, clarithromycin and the internal standard are eluted in this order with the resolution between these peaks being not less than 3.

System repeatability: When the test is repeated 6 times with 10 μ L of the standard solution under the above operating conditions, the relative standard deviation of the ratio of the peak area of clarithromycin to that of the internal standard is not more than 2.0%.

Containers and storage Containers—Well-closed containers.

Clebopride Malate

クレボプリドリンゴ酸塩

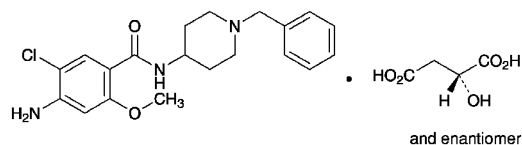

$C_{20}H_{24}ClN_3O_2 \cdot C_4H_6O_5$: 507.96
 4-Amino-*N*-(1-benzylpiperidin-4-yl)-5-chloro-2-methoxybenzamide mono-(2*RS*)-malate
 [57645-91-7]

Clebopride Malate, when dried, contains not less than 98.5% and not more than 101.0% of clebopride malate ($C_{20}H_{24}ClN_3O_2 \cdot C_4H_6O_5$).

Description Clebopride Malate occurs as a white crystalline powder.

It is freely soluble in acetic acid (100), soluble in methanol, sparingly soluble in water, and slightly soluble in ethanol (99.5).

A solution of Clebopride Malate in methanol (1 in 25) shows no optical rotation.

Identification (1) Determine the absorption spectrum of a solution of Clebopride Malate in methanol (1 in 80000) as directed under Ultraviolet-visible Spectrophotometry <2.24>, and compare the spectrum with the Reference Spectrum: both spectra exhibit similar intensities of absorption at the same wavelengths.

(2) Determine the infrared absorption spectrum of Clebopride Malate, previously dried, as directed in the potassium bromide disk method under Infrared Spectrophotometry <2.25>, and compare the spectrum with the Reference Spectrum: both spectra exhibit similar intensities of absorption at the same wave numbers.

(3) Perform the test with Clebopride Malate under Flame Coloration Test <1.04> (2): a green color appears.

Purity (1) Chloride <1.03>—Dissolve 1.0 g of Clebopride Malate in 20 mL of acetic acid (100), add 6 mL of dilute nitric acid and water to make 50 mL. Perform the test using this solution as the test solution. Prepare the control solution with 0.25 mL of 0.01 mol/L hydrochloric acid VS by adding 20 mL of acetic acid (100), 6 mL of dilute nitric acid and water to make 50 mL (not more than 0.009%).

(2) Heavy metals <1.07>—Proceed with 2.0 g of Clebopride Malate according to Method 2, and perform the test. Prepare the control solution with 2.0 mL of Standard Lead Solution (not more than 10 ppm).

(3) Related substances—Dissolve 0.10 g of Clebopride Malate in 10 mL of the mobile phase, and use this solution as the sample solution. Pipet 0.2 mL of the sample solution, add the mobile phase to make exactly 100 mL, and use this solution as the standard solution. Perform the test with exactly 10 μ L each of the sample solution and standard solution as directed under Liquid Chromatography <2.01> according to the following conditions. Determine each peak area of both solutions by the automatic integration method: the total area of the peaks other than clebopride obtained from the sample solution is not larger than the peak area of clebopride from the standard solution.

Operating conditions—

Detector: An ultraviolet absorption photometer (wavelength: 240 nm).

Column: A stainless steel column 4.6 mm in inside diameter and 25 cm in length, packed with octadecylsilanized silica gel for liquid chromatography (7 μ m in particle diameter).

Column temperature: A constant temperature of about 25°C.

Mobile phase: Dissolve 3.85 g of ammonium acetate in water to make 500 mL, and filter through a membrane filter with a pore size not exceeding 0.5 μ m. To 400 mL of the filtrate add 600 mL of methanol.

Flow rate: Adjust so that the retention time of clebopride is about 15 minutes.

Time span of measurement: About 2 times as long as the retention time of clebopride.

System suitability—

Test for required detectability: Pipet 10 mL of the standard solution, and add water to make exactly 100 mL. Confirm that the peak area of clebopride obtained with 10 μ L of this solution is equivalent to 7 to 13% of that with 10 μ L of the standard solution.

System performance: Dissolve 30 mg Clebopride Malate and 5 mg of propyl parahydroxybenzoate in the mobile phase to make 100 mL. When the procedure is run with 10 μ L of this solution under the above operating conditions, propyl parahydroxybenzoate and clebopride are eluted in this order with the resolution between these peaks being not less than 3.

System repeatability: When the test is repeated 6 times with 10 μ L of the standard solution under the above operating conditions, the relative standard deviation of the peak area of clebopride is not more than 2.5%.

Loss on drying <2.41> Not more than 0.5% (1 g, 105°C, 4 hours).

Residue on ignition <2.44> Not more than 0.1% (1 g).

Assay Weigh accurately about 0.5 g of Clebopride Malate, previously dried, dissolve in 30 mL of acetic acid (100), and titrate <2.50> with 0.1 mol/L perchloric acid VS (potentiometric titration). Perform a blank determination in the same manner, and make any necessary correction.

Each mL of 0.1 mol/L perchloric acid VS
= 50.80 mg of C₂₀H₂₄ClN₃O₂·C₄H₆O₅

Containers and storage Containers—Tight containers.

Clemastine Fumarate

クレマスチンフマル酸塩

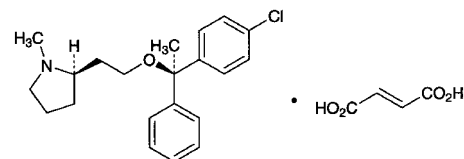

C₂₁H₂₆ClNO·C₄H₄O₄: 459.96
(2*R*)-2-[2-[(1*R*)-1-(4-Chlorophenyl)-1-phenylethoxy]ethyl]-1-methylpyrrolidine monofumarate
[14976-57-9]

Clemastine Fumarate, when dried, contains not less than 98.5% of clemastine fumarate (C₂₁H₂₆ClNO·C₄H₄O₄).

Description Clemastine Fumarate occurs as a white, crystalline powder. It is odorless.

It is sparingly soluble in methanol and in acetic acid (100), slightly soluble in ethanol (95), very slightly soluble in diethyl ether, and practically insoluble in water.

Identification (1) To 5 mg of Clemastine Fumarate add 5 mL of sulfuric acid, and shake to dissolve: a yellow color develops. Slowly drop this solution into 10 mL of water: the yellow color immediately disappears.

(2) To 0.01 g of Clemastine Fumarate add 1 mL of fuming nitric acid, and evaporate on a water bath to dryness. Then add 2 mL of diluted hydrochloric acid (1 in 2) and 0.2 g of zinc powder, heat for 10 minutes on a water bath, cool, and filter. Add 20 mL of water to the filtrate. The solution responds to Qualitative Tests <1.09> for primary aromatic amines.

(3) To 5 mL of a solution of Clemastine Fumarate (1 in 50,000), add 5 mL of 4-dimethylaminobenzaldehyde TS, and warm for 10 minutes: a red-purple color develops.

(4) Perform the test with Clemastine Fumarate as directed under Flame Coloration Test <1.04> (2): a green color appears.

(5) Dissolve 0.04 g of Clemastine Fumarate and 0.01 g of fumaric acid for thin-layer chromatography in 2 mL each of a mixture of ethanol (95) and water (4:1) by gentle warming, and use these solutions as the sample solution and the standard solution, respectively. Perform the test with these solutions as directed under Thin-layer Chromatography <2.03>. Spot 5 μ L each of the sample solution and standard solution on a plate of silica gel with fluorescent indicator for thin-layer chromatography. Develop the plate with a mixture of isopropyl ether, formic acid and water (90:7:3) to a distance of about 10 cm, and air-dry the plate. Examine the plate under ultraviolet light (main wavelength: 254 nm): the spot with larger *R_f* value from the sample solution has the same *R_f* value as the spot from the standard solution.

Optical rotation <2.49> [α]_D²⁰: +16 – +18° (after drying, 0.1 g, methanol, 10 mL, 100 mm).

Melting point <2.60> 176 – 180°C (with decomposition).

Purity (1) Clarity and color of solution—Dissolve 0.5 g of Clemastine Fumarate in 10 mL of methanol by warming: the solution is clear and colorless.

(2) Heavy metals <1.07>—Perform the test with 1.0 g of Clemastine Fumarate according to Method 2. Prepare the control solution with 2.0 mL of Standard Lead Solution (not

more than 20 ppm).

(3) Arsenic <1.11>—Take 1.0 g of Clemastine Fumarate, prepare the test solution according to Method 3, and perform the test (not more than 2 ppm).

(4) Related Substances—Dissolve 0.10 g of Clemastine Fumarate in 5 mL of methanol, and use this solution as the sample solution. Pipet 1 mL of the sample solution, add methanol to make exactly 250 mL, and use this solution as the standard solution (1). Pipet 5 mL of the standard solution (1), add methanol to make exactly 10 mL, and use this solution as the standard solution (2). Perform the test with these solutions as directed under Thin-layer Chromatography <2.03>. Spot 5 μ L each of the sample solution and standard solutions (1) and (2) on a plate of silica gel for thin-layer chromatography. Develop the plate with a mixture of chloroform, methanol and ammonia solution (28) (90:10:1) to a distance of about 15 cm, and air-dry the plate. After spraying evenly Dragendorff's TS on the plate, immediately spray evenly hydrogen peroxide TS: the spots other than the principal spot obtained from the sample solution are not more intense than the spot from the standard solution (1), and not more than 2 spots from the sample solution are more intense than the spot from the standard solution (2).

Loss on drying <2.41> Not more than 0.5% (1 g, 105°C, 4 hours).

Residue on ignition <2.44> Not more than 0.2% (1 g).

Assay Weigh accurately about 0.4 g of Clemastine Fumarate, previously dried, dissolved in 50 mL of acetic acid (100), and titrate <2.50> with 0.1 mol/L perchloric acid VS (potentiometric titration). Perform a blank determination in the same manner, and make any necessary correction.

Each mL of 0.1 mol/L perchloric acid VS
= 46.00 mg of $C_{21}H_{26}ClNO \cdot C_4H_4O_4$

Containers and storage Containers—Tight containers.

Clindamycin Hydrochloride

クリンダマイシン塩酸塩

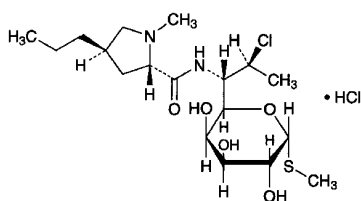

$C_{18}H_{33}ClN_2O_5S \cdot HCl$: 461.44

Methyl 7-chloro-6,7,8-trideoxy-6-[(2S,4R)-1-methyl-4-propylpyrrolidine-2-carboxamido]-1-thio-L-threo- α -D-galacto-octopyranoside monohydrochloride
[21462-39-5]

Clindamycin Hydrochloride is the hydrochloride of a derivative of lincomycin.

It contains not less than 838 μ g (potency) and not more than 940 μ g (potency) per mg, calculated on the anhydrous basis. The potency of Clindamycin Hydrochloride is expressed as mass (potency) of clindamycin ($C_{18}H_{33}ClN_2O_5S$: 424.98).

Description Clindamycin Hydrochloride occurs as white to grayish white, crystals or crystalline powder.

It is freely soluble in water and in methanol, and slightly

soluble in ethanol (99.5).

Identification (1) Determine the infrared absorption spectrum of Clindamycin Hydrochloride as directed in the potassium chloride disk method under Infrared Spectrophotometry <2.25>, and compare the spectrum with the Reference Spectrum or the spectrum of Clindamycin Hydrochloride RS: both spectra exhibit similar intensities of absorption at the same wave numbers.

(2) A solution of Clindamycin Hydrochloride (1 in 100) responds to Qualitative Tests <1.09> (2) for chloride.

Optical rotation <2.49> $[\alpha]_D^{25}$: +135 – +150° (0.5 g calculated on the anhydrous basis, water, 25 mL, 100 mm).

Purity (1) Heavy metals <1.07>—Proceed with 2.0 g of Clindamycin Hydrochloride according to Method 4, and perform the test. Prepare the control solution with 2.0 mL of Standard Lead Solution (not more than 10 ppm).

(2) Related substances—Use the sample solution obtained in the Assay as the sample solution. Pipet 1 mL of the sample solution, add the mobile phase to make exactly 100 mL, and use this solution as the standard solution. Perform the test with exactly 20 μ L each of the sample solution and standard solution as directed under Liquid Chromatography <2.01> according to the following conditions, and determine each peak area by the automatic integration method: the peak area of clindamycin B, having the relative retention time of about 0.7 to clindamycin, and that of 7-epiclindamycin, having the relative retention time of about 0.8, obtained from the sample solution are not larger than 2 times the peak area of clindamycin from the standard solution, the area of the peak other than clindamycin and the peaks mentioned above from the sample solution is not larger than the peak area of clindamycin from the standard solution, and the total area of the peaks other than clindamycin from the sample solution is not larger than 4 times the peak area of clindamycin from the standard solution.

Operating conditions—

Detector, column, column temperature, mobile phase, and flow rate: Proceed as directed in the operating conditions in the Assay.

Time span of measurement: About 2 times as long as the retention time of clindamycin, beginning after the solvent peak.

System suitability—

Test for required detectability: Pipet 1 mL of the standard solution, and add the mobile phase to make exactly 10 mL. Confirm that the peak area of clindamycin obtained with 20 μ L of this solution is equivalent to 7 to 13% of that with 20 μ L of the standard solution.

System performance: When the procedure is run with 20 μ L of the standard solution under the above operating conditions, the number of theoretical plates and the symmetry factor of the peak of clindamycin are not less than 6000 and not more than 1.5, respectively.

System repeatability: When the test is repeated 6 times with 20 μ L of the standard solution under the above operating conditions, the relative standard deviation of the peak area of clindamycin is not more than 2.0%.

Water <2.48> Not more than 6.0% (0.3 g, volumetric titration, direct titration).

Assay Weigh accurately an amount of Clindamycin Hydrochloride and Clindamycin Hydrochloride RS, equivalent to about 20 mg (potency), dissolve each in the mobile phase to make exactly 20 mL, and use these solutions as the sample solution and the standard solution, respectively. Perform the

test with exactly 20 μ L each of the sample solution and standard solution as directed under Liquid Chromatography <2.01> according to the following conditions, and determine the peak areas, A_T and A_S , of clindamycin in each solution.

$$\begin{aligned} \text{Amount } [\mu\text{g (potency)}] \text{ of clindamycin (C}_{18}\text{H}_{33}\text{ClN}_2\text{O}_5\text{S)} \\ = M_S \times A_T/A_S \times 1000 \end{aligned}$$

M_S : Amount [mg (potency)] of Clindamycin Hydrochloride RS taken

Operating conditions—

Detector: An ultraviolet absorption photometer (wavelength: 210 nm).

Column: A stainless steel column 4.6 mm in inside diameter and 25 cm in length, packed with octadecylsilanized silica gel for liquid chromatography (5 μ m in particle diameter).

Column temperature: A constant temperature of about 25°C.

Mobile phase: To 0.05 mol/L potassium dihydrogen phosphate TS add 8 mol/L potassium hydroxide TS to adjust the pH to 7.5. To 550 mL of this solution add 450 mL of acetonitrile for liquid chromatography.

Flow rate: Adjust so that the retention time of clindamycin is about 10 minutes.

System suitability—

System performance: When the procedure is run with 20 μ L of the standard solution under the above operating conditions, the number of theoretical plates and the symmetry factor of the peak of clindamycin are not less than 6000 and not more than 1.5, respectively.

System repeatability: When the test is repeated 6 times with 20 μ L of the standard solution under the above operating conditions, the relative standard deviation of the peak area of clindamycin is not more than 1.0%.

Containers and storage Containers—Tight containers.

Clindamycin Hydrochloride Capsules

クリンダマイシン塩酸塩カプセル

Clindamycin Hydrochloride Capsules contain not less than 93.0% and not more than 107.0% of the labeled potency of clindamycin (C₁₈H₃₃ClN₂O₅S; 424.98).

Method of preparation Prepare as directed under Capsules, with Clindamycin Hydrochloride.

Identification To an amount of the contents of Clindamycin Hydrochloride Capsules, equivalent to 10 mg (potency) of Clindamycin Hydrochloride, add 2 mL of methanol, shake well, centrifuge, and use the supernatant liquid as the sample solution. Separately, dissolve 10 mg of Clindamycin Hydrochloride RS in 2 mL of methanol, and use this solution as the standard solution. Perform the test with these solutions as directed under Thin-layer Chromatography <2.03>. Spot 10 μ L each of the sample solution and standard solution on a plate of silica gel for thin-layer chromatography. Develop the plate with a mixture of methanol, toluene and ammonia solution (28) (140:60:3) to a distance of about 12 cm, and air-dry the plate. Spray evenly a mixture of 500 mL of a solution of L-tartaric acid (1 in 5) and 50 mL of bismuth subnitrate TS on the plate: the R_f values of the principal spot with the sample solution and the spot with the standard solution are not different each other.

Uniformity of dosage units <6.02> Perform the test according to the following method: it meets the requirement of the Content uniformity test.

To 1 capsule of Clindamycin Hydrochloride Capsules add a suitable amount of the mobile phase, shake for 30 minutes, and add the mobile phase to make exactly V mL so that each mL contains 0.75 mg (potency) of Clindamycin Hydrochloride. Centrifuge this solution, and use the supernatant liquid as the sample solution. Then, proceed as directed in the Assay.

$$\begin{aligned} \text{Amount [mg (potency)] of clindamycin (C}_{18}\text{H}_{33}\text{ClN}_2\text{O}_5\text{S)} \\ = M_S \times A_T/A_S \times V/100 \end{aligned}$$

M_S : Amount [mg (potency)] of Clindamycin Hydrochloride RS taken

Dissolution <6.10> When the test is performed at 50 revolutions per minute according to the Paddle method using the sinker, using 900 mL of water as the dissolution medium, the dissolution rate of a 75-mg capsule in 15 minutes and that of a 150-mg capsule in 30 minutes are not less than 80%, respectively.

Start the test with 1 capsule of Clindamycin Hydrochloride Capsules, withdraw not less than 20 mL of the medium at the specified minute after starting the test, and filter through a membrane filter with a pore size not exceeding 0.45 μ m. Discard not less than 10 mL of the first filtrate, pipet V' mL of the subsequent filtrate, add water to make exactly V' so that each mL contains about 83 μ g (potency) of Clindamycin Hydrochloride, and use this solution as the sample solution. Separately, weigh accurately an amount of Clindamycin Hydrochloride RS, equivalent to about 17 mg (potency), dissolve in water to make exactly 200 mL, and use this solution as the standard solution. Perform the test with exactly 20 μ L each of the sample solution and standard solution as directed under Liquid Chromatography <2.01>, and determine the peak areas, A_T and A_S , of clindamycin in each solution.

$$\begin{aligned} \text{Dissolution rate (\%)} \text{ with respect to the labeled amount} \\ \text{of clindamycin (C}_{18}\text{H}_{33}\text{ClN}_2\text{O}_5\text{S)} \\ = M_S \times A_T/A_S \times V'/V \times 1/C \times 450 \end{aligned}$$

M_S : Amount [mg (potency)] of Clindamycin Hydrochloride RS taken

C : Labeled amount [mg (potency)] of clindamycin (C₁₈H₃₃ClN₂O₅S) in 1 tablet

Operating conditions—

Detector: An ultraviolet absorption photometer (wavelength: 210 nm).

Column: A stainless steel column 4.6 mm in inside diameter and 15 cm in length, packed with octadecylsilanized silica gel for liquid chromatography (5 μ m in particle diameter).

Column temperature: A constant temperature of about 40°C.

Mobile phase: Adjust the pH of 0.05 mol/L potassium dihydrogen phosphate TS to 7.5 with 8 mol/L potassium hydroxide TS. To 550 mL of this solution add 450 mL of acetonitrile.

Flow rate: Adjust so that the retention time of clindamycin is about 7 minutes.

System suitability—

System performance: When the procedure is run with 20 μ L of the standard solution under the above operating conditions, the number of theoretical plates and the symmetry factor of the peak of clindamycin are not less than 3000 and not more than 2.0, respectively.

System repeatability: When the test is repeated 6 times

with 20 μL of the standard solution under the above operating conditions, the relative standard deviation of the peak area of clindamycin is not more than 2.0%.

Assay Take out the contents of not less than 20 Clindamycin Hydrochloride Capsules, weigh accurately the mass of the contents, and powder. Weigh accurately a portion of the powder, equivalent to about 75 mg (potency) of Clindamycin Hydrochloride, add the mobile phase, shake for 30 minutes, and add the mobile phase to make exactly 100 mL. Centrifuge this solution, and use the supernatant liquid as the sample solution. Separately, weigh accurately an amount of Clindamycin Hydrochloride RS, equivalent to about 75 mg (potency), dissolve in the mobile phase to make exactly 100 mL, and use this solution as the standard solution. Perform the test with exactly 20 μL each of the sample solution and standard solution as directed under Liquid Chromatography <2.01> according to the following conditions, and determine the peak areas, A_T and A_S , of clindamycin in each solution.

$$\text{Amount [mg (potency)] of clindamycin (C}_{18}\text{H}_{33}\text{ClN}_2\text{O}_5\text{S)} \\ = M_S \times A_T / A_S$$

M_S : Amount [mg (potency)] of Clindamycin Hydrochloride RS taken

Operating conditions—

Detector: An ultraviolet absorption photometer (wavelength: 210 nm).

Column: A stainless steel column 4.6 mm in inside diameter and 15 cm in length, packed with octadecylsilanized silica gel for liquid chromatography (5 μm in particle diameter).

Column temperature: A constant temperature of about 40°C.

Mobile phase: To 0.05 mol/L of potassium dihydrogen phosphate TS add 8 mol/L potassium hydroxide TS to adjust the pH to 7.5. To 550 mL of this solution add 450 mL of acetonitrile for liquid chromatography.

Flow rate: Adjust so that the retention time of clindamycin is about 7 minutes.

System suitability—

System performance: When the procedure is run with 20 μL of the standard solution under the above operating conditions, the number of theoretical plates and the symmetry factor of the peak of clindamycin are not less than 3000 and not more than 2.0, respectively.

System repeatability: When the test is repeated 6 times with 20 μL of the standard solution under the above operating conditions, the relative standard deviation of the peak area of clindamycin is not more than 1.0%.

Containers and storage Containers—Tight containers.

Clindamycin Phosphate

クリンダマイシンリン酸エステル

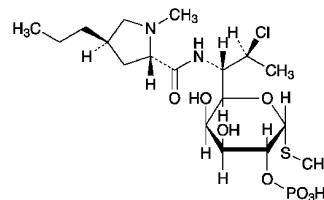

$\text{C}_{18}\text{H}_{34}\text{ClN}_2\text{O}_8\text{PS}$: 504.96

Methyl 7-chloro-6,7,8-trideoxy-6-[(2S,4R)-1-methyl-4-propylpyrrolidine-2-carboxamido]-1-thio-L-threo- α -D-galacto-octopyranoside 2-dihydrogen phosphate [24729-96-2]

Clindamycin Phosphate is a derivative of clindamycin.

It contains not less than 800 μg (potency) and not more than 846 μg (potency) per mg, calculated on the anhydrous basis. The potency of Clindamycin Phosphate is expressed as mass (potency) of clindamycin ($\text{C}_{18}\text{H}_{33}\text{ClN}_2\text{O}_5\text{S}$: 424.98).

Description Clindamycin Phosphate occurs as a white to pale yellow-white crystalline powder.

It is freely soluble in water, sparingly soluble in methanol, and practically insoluble in ethanol (95).

Identification Determine the infrared absorption spectrum of Clindamycin Phosphate, previously dried at 100°C for 2 hours, as directed in the paste method under Infrared Spectrophotometry <2.25>, and compare the spectrum with the Reference Spectrum or the spectrum of Clindamycin Phosphate RS previously dried at 100°C for 2 hours: both spectra exhibit similar intensities of absorption at the same wave numbers.

Optical rotation <2.49> $[\alpha]_D^{20}$: +115 – +130° (0.25 g calculated on the anhydrous basis, water, 25 mL, 100 mm).

pH <2.54> Dissolve 0.10 g of Clindamycin Phosphate in 10 mL of water. The pH of the solution is between 3.5 and 4.5.

Purity (1) Clarity and color of solution—Dissolve 1.0 g of Clindamycin Phosphate in 10 mL of freshly boiled and cooled water: the solution is clear and colorless.

(2) Heavy metals <1.07>—Proceed with 2.0 g of Clindamycin Phosphate according to Method 4, and perform the test. Prepare the control solution with 1.0 mL of Standard Lead Solution (not more than 5 ppm).

(3) Arsenic <1.11>—Prepare the test solution with 1.0 g of Clindamycin Phosphate according to Method 4, and perform the test (not more than 2 ppm).

(4) Related substances—Dissolve 0.1 g of Clindamycin Phosphate in 100 mL of the mobile phase, and use this solution as the sample solution. Pipet 1 mL of the sample solution, add the mobile phase to make exactly 100 mL, and use this solution as the standard solution. Perform the test with exactly 20 μL each of the sample solution and standard solution as directed under Liquid Chromatography <2.01> according to the following conditions, and determine each peak area by the automatic integration method: the peak area of clindamycin, having the relative retention time of about 1.8 to clindamycin phosphate, obtained from the sample solution is not larger than 1/2 times the peak area of clindamycin phosphate from the standard solution, and the total

area of the peaks other than clindamycin phosphate from the sample solution is not larger than 4 times the peak area of clindamycin phosphate from the standard solution.

Operating conditions—

Detector, column, column temperature, mobile phase, and flow rate: Proceed as directed in the operating conditions in the Assay.

Time span of measurement: About 2 times as long as the retention time of clindamycin phosphate, beginning after the solvent peak.

System suitability—

System performance, and system repeatability: Proceed as directed in the system suitability in the Assay.

Test for required detectability: Measure exactly 1 mL of the standard solution, and add the mobile phase to make exactly 10 mL. Confirm that the peak area of clindamycin phosphate obtained with 20 μ L of this solution is equivalent to 7 to 13% of that with 20 μ L of the standard solution.

Water <2.48> Not more than 6.0% (0.5 g, volumetric titration, direct titration).

Assay Weigh accurately an amount of Clindamycin Phosphate and Clindamycin Phosphate RS, equivalent to about 20 mg (potency), add exactly 25 mL of the internal standard solution and the mobile phase to make 100 mL, and use these solutions as the sample solution and standard solution. Perform the test with 20 μ L each of the sample solution and standard solution as directed under Liquid Chromatography <2.01> according to the following conditions, and calculate the ratios, Q_T and Q_S , of the peak area of clindamycin phosphate to that of the internal standard.

$$\begin{aligned} \text{Amount } [\mu\text{g (potency)}] \text{ of clindamycin (C}_{18}\text{H}_{33}\text{ClN}_2\text{O}_5\text{S)} \\ = M_S \times Q_T/Q_S \times 1000 \end{aligned}$$

M_S : Amount [mg (potency)] of Clindamycin Phosphate RS taken

Internal standard solution—A solution of methyl parahydroxybenzoate in the mobile phase (3 in 50,000).

Operating conditions—

Detector: An ultraviolet absorption photometer (wavelength: 210 nm).

Column: A stainless steel column 4 mm in inside diameter and 25 cm in length, packed with octylsilanized silica gel for liquid chromatography (5 μ m in particle diameter).

Column temperature: A constant temperature of about 25°C.

Mobile phase: Dissolve 10.54 g of potassium dihydrogen phosphate in 775 mL of water, adjust the pH to 2.5 with phosphoric acid, and add 225 mL of acetonitrile.

Flow rate: Adjust so that the retention time of clindamycin phosphate is about 8 minutes.

System suitability—

System performance: When the procedure is run with 20 μ L of the standard solution under the above operating conditions, clindamycin phosphate and the internal standard are eluted in this order with the resolution between these peaks being not less than 4.

System repeatability: When the test is repeated 6 times with 20 μ L of the standard solution under the above operating conditions, the relative standard deviation of the ratios of the peak area of clindamycin phosphate to that of the internal standard is not more than 2.5%.

Containers and storage Containers—Tight containers.

Clindamycin Phosphate Injection

クリンダマイシンリン酸エステル注射液

Clindamycin Phosphate Injection is an aqueous injection.

It contains not less than 90.0% and not more than 110.0% of the labeled potency of clindamycin phosphate (C₁₈H₃₄ClN₂O₈PS: 504.96).

Method of preparation Prepare as directed under Injections, with Clindamycin Phosphate.

Description Clindamycin Phosphate Injection is a clear, colorless or light yellow liquid.

Identification To a volume of Clindamycin Phosphate Injection, equivalent to 0.15 g (potency) of Clindamycin Phosphate, add 4 mL of water, 2 mL of 8 mol/L sodium hydroxide TS and 0.1 mL of sodium pentacyanonitrosylferrate (III) TS, mix, heat in a water bath for 10 minutes, and add 2 mL of hydrochloric acid: a blue-green color develops.

Osmotic pressure ratio Being specified separately when the drug is granted approval based on the Law.

pH <2.54> 6.0 – 7.0

Bacterial endotoxins <4.01> Less than 0.1 EU/mg (potency).

Extractable volume <6.05> It meets the requirement.

Foreign insoluble matter <6.06> Perform the test according to Method 1: it meets the requirement.

Insoluble particulate matter <6.07> It meets the requirement.

Sterility <4.06> Perform the test according to the Membrane filtration method: it meets the requirement.

Assay Measure exactly a volume of Clindamycin Phosphate Injection, equivalent to about 0.3 g (potency) of Clindamycin Phosphate, and add the mobile phase to make exactly 100 mL. Pipet 7 mL of this solution, add exactly 25 mL of the internal standard solution and the mobile phase to make 100 mL, and use this solution as the sample solution. Separately, weigh accurately an amount of Clindamycin Phosphate RS, equivalent to about 20 mg (potency), dissolve in exactly 25 mL of the internal standard solution, add the mobile phase to make 100 mL, and use this solution as the standard solution. Then, proceed as directed in the Assay under Clindamycin Phosphate.

$$\begin{aligned} \text{Amount [mg (potency)] of clindamycin phosphate} \\ (\text{C}_{18}\text{H}_{34}\text{ClN}_2\text{O}_8\text{PS}) \\ = M_S \times Q_T/Q_S \times 100/7 \end{aligned}$$

M_S : Amount [mg (potency)] of Clindamycin Phosphate RS taken

Internal standard solution—A solution of methyl parahydroxybenzoate in the mobile phase (3 in 50,000).

Containers and storage Containers—Hermetic containers.

Clinofibrate

クリノフィブラート

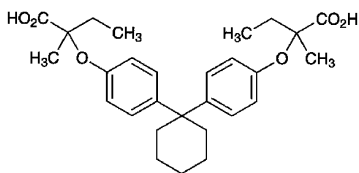

$C_{28}H_{36}O_6$: 468.58

2,2'-[Cyclohexane-1,1-diylbis(4,1-phenyleneoxy)]bis(2-methylbutanoic acid)

[30299-08-2]

Clinofibrate, when dried, contains not less than 98.5% of clinofibrate ($C_{28}H_{36}O_6$).

Description Clinofibrate occurs as a white to yellowish white powder. It is odorless and has no taste.

It is freely soluble in methanol, in ethanol (99.5), in acetone and in diethyl ether, and practically insoluble in water.

A solution of Clinofibrate in methanol (1 in 20) shows no optical rotation.

Melting point: about 146°C (with decomposition).

Identification (1) Determine the absorption spectrum of a solution of Clinofibrate in ethanol (99.5) (1 in 50,000) as directed under Ultraviolet-visible Spectrophotometry <2.24>, and compare the spectrum with the Reference Spectrum: both spectra exhibit similar intensities of absorption at the same wavelengths.

(2) Determine the infrared absorption spectrum of Clinofibrate, previously dried, as directed in the potassium bromide disk method under Infrared Spectrophotometry <2.25>, and compare the spectrum with the Reference Spectrum: both spectra exhibit similar intensities of absorption at the same wave numbers.

Purity (1) Heavy metals <1.07>—Proceed with 1.0 g of Clinofibrate according to Method 2, and perform the test. Prepare the control solution with 2.0 mL of Standard Lead Solution (not more than 20 ppm).

(2) Arsenic <1.11>—Prepare the test solution with 1.0 g of Clinofibrate according to Method 3, and perform the test (not more than 2 ppm).

(3) Related substances—Dissolve 0.10 g of Clinofibrate in 10 mL of acetone, and use this solution as the sample solution. Pipet 1 mL of the sample solution, and add acetone to make exactly 50 mL. Pipet 5 mL of this solution, add acetone to make exactly 20 mL, and use this solution as the standard solution. Perform the test with these solutions as directed under Thin-layer Chromatography <2.03>. Spot 50 μ L each of the sample solution and standard solution on a plate of silica gel with fluorescent indicator for thin-layer chromatography. Develop the plate with a mixture of chloroform, cyclohexane and acetic acid (100) (12:5:3) to a distance of about 12 cm, and air-dry the plate. Examine under ultraviolet light (main wavelength: 254 nm): the spots other than the principal spot obtained from the sample solution are not more intense than the spot from the standard solution.

Loss on drying <2.41> Not more than 1.0% (1 g, in vacuum, 60°C, 3 hours).

Residue on ignition <2.44> Not more than 0.2% (1 g).

Isomer ratio To 50 mg of Clinofibrate add 0.4 mL of thionyl chloride, stopper tightly, heat on a water bath of 60°C for 5 minutes with occasional shaking, and evaporate the excess thionyl chloride at a temperature not exceeding 60°C under reduced pressure. Dissolve the residue in 2 mL of toluene previously dried with synthetic zeolite for drying, add 2 mL of a solution of D-(+)- α -methylbenzylamine in toluene previously dried with synthetic zeolite for drying (3 in 100), mix gently, allow to stand for 10 minutes, and evaporate the toluene at a temperature not exceeding 60°C under reduced pressure. Dissolve the residue in 5 mL of chloroform, and use this solution as the sample solution. Perform the test with 5 μ L of the sample solution as directed under Liquid Chromatography <2.01> according to the following conditions. Determine each peak area, A_a , A_b and A_c , of three peaks appear in order near the retention time of 40 minutes: a value, $A_b/(A_a + A_b + A_c) \times 100$, is between 40 and 70.

Operating conditions—

Detector: An ultraviolet absorption photometer (wavelength: 254 nm).

Column: A stainless steel column about 4 mm in inside diameter and about 30 cm in length, packed with silica gel for liquid chromatography (5 μ m in particle diameter).

Column temperature: A constant temperature of about 20°C.

Mobile phase: A mixture of hexane and 2-propanol (500:3).

Flow rate: Adjust so that the retention time of the peak appearing first is about 35 minutes.

Selection of column: Proceed with 5 μ L of the sample solution under the above operating conditions. Use a column giving a complete separation of the three peaks.

Assay Weigh accurately about 0.45 g of Clinofibrate, previously dried, dissolve in 40 mL of ethanol (99.5), add 30 mL of water, and titrate <2.50> with 0.1 mol/L sodium hydroxide VS (indicator: 3 drops of phenolphthalein TS). Perform a blank determination in the same manner, and make any necessary correction.

Each mL of 0.1 mol/L sodium hydroxide VS
= 23.43 mg of $C_{28}H_{36}O_6$

Containers and storage Containers—Tight containers.

Clobetasol Propionate

クロベタゾールプロピオン酸エステル

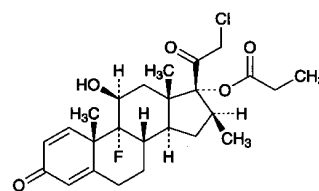

$C_{25}H_{32}ClFO_5$: 466.97

21-Chloro-9-fluoro-11 β ,17-dihydroxy-16 β -methylpregna-1,4-diene-3,20-dione 17-propanoate
[25122-46-7]

Clobetasol Propionate, when dried, contains not less than 97.0% and not more than 102.0% of clobetasol propionate ($C_{25}H_{32}ClFO_5$).

Description Clobetasol Propionate occurs as a white to pale yellow-white crystalline powder.

It is soluble in methanol and in ethanol (99.5), and practically insoluble in water.

It gradually turns yellow by light.

Melting point: about 196°C (with decomposition).

Identification Determine the infrared absorption spectra of Clobetasol Propionate as directed in the paste method under Infrared Spectrophotometry <2.25>, and compare the spectrum with the Reference Spectrum or the spectrum of Clobetasol Propionate RS: both spectra exhibit similar intensities of absorbance at the same wave numbers.

Optical rotation <2.49> $[\alpha]_D^{20}$: +109 – +115° (after drying, 0.1 g, methanol, 10 mL, 100 mm).

Purity (1) Heavy metals <1.07>—Proceed with 1.0 g of Clobetasol Propionate according to Method 2, and perform the test. Prepare the control solution with 2.0 mL of Standard Lead Solution (not more than 20 ppm).

(2) Related substances—Dissolve 10 mg of Clobetasol Propionate in 100 mL of the mobile phase, and use this solution as the sample solution. Pipet 5 mL of the sample solution, add the mobile phase to make exactly 200 mL, and use this solution as the standard solution. Perform the test with exactly 10 μ L each of the sample solution and standard solution as directed under Liquid Chromatography <2.01> according to the following conditions, and determine each peak area of these solutions by the automatic integration method: the area of the peak other than clobetasol propionate obtained from the sample solution is not larger than 2/5 times the peak area of clobetasol propionate from the standard solution. Furthermore, the total area of the peaks other than clobetasol propionate from the sample solution is not larger than the peak area of clobetasol propionate from the standard solution.

Operating conditions—

Detector, column, column temperature, mobile phase, and flow rate: Proceed as directed in the operating conditions in the Assay.

Time span of measurement: About 2.5 times as long as the retention time of clobetasol propionate, beginning after the solvent peak.

System suitability—

Test for required detectability: Pipet 2 mL of the standard solution, and add the mobile phase to make exactly 50 mL. Confirm that the peak area of clobetasol propionate obtained with 10 μ L of this solution is equivalent to 2.8 to 5.2% of that with 10 μ L of the standard solution.

System performance: Dissolve 20 mg of Clobetasol Propionate in 20 mL of methanol. To 5 mL of this solution add 10 mL of a solution of beclometasone dipropionate in methanol (1 in 1000), and then add the mobile phase to make 50 mL. When the procedure is run with 10 μ L of this solution under the above conditions, clobetasol propionate and beclometasone dipropionate are eluted in this order with the resolution between these peaks being not less than 8.

System repeatability: When the test is repeated 6 times with 10 μ L of the standard solution under the above conditions, the relative standard deviation of the peak area of clobetasol propionate is not more than 2.0%.

Loss on drying <2.41> Not more than 0.5% (1 g, 105°C, 3 hours).

Residue on ignition <2.44> Not more than 0.1% (1 g, platinum crucible).

Assay Weigh accurately about 10 mg each of Clobetasol Propionate and Clobetasol Propionate RS, both previously dried, dissolve each in the mobile phase, add exactly 100 mL

of the internal standard solution, add the mobile phase to make 250 mL, and use these solutions as the sample solution and standard solution. Perform the test with 10 μ L each of the sample solution and standard solution as directed under Liquid Chromatography <2.01> according to the following conditions, and calculate the ratios, Q_T and Q_S , of the peak area of clobetasol propionate to that of the internal standard.

$$\text{Amount (mg) of clobetasol propionate (C}_{25}\text{H}_{32}\text{ClFO}_5) = M_S \times Q_T/Q_S$$

M_S : Amount (mg) of Clobetasol Propionate RS taken

Internal standard solution—A solution of beclometasone dipropionate in the mobile phase (1 in 5000).

Operating conditions—

Detector: An ultraviolet absorption photometer (wavelength: 240 nm).

Column: A stainless steel column 4.6 mm in inside diameter and 15 cm in length, packed with octadecylsilanized silica gel for liquid chromatography (5 μ m in particle diameter).

Column temperature: A constant temperature of about 25°C.

Mobile phase: Dissolve 7.80 g of sodium dihydrogen phosphate dihydrate in 900 mL of water, adjust the pH to 2.5 with phosphoric acid, and then add water to make 1000 mL. To 425 mL of this solution add 475 mL of acetonitrile and 100 mL of methanol.

Flow rate: Adjust so that the retention time of clobetasol propionate is about 10 minutes.

System suitability—

System performance: When the procedure is run with 10 μ L of the standard solution under the above conditions, clobetasol propionate and the internal standard are eluted in this order with the resolution between these peaks being not less than 8.

System repeatability: When the test is repeated 6 times with 10 μ L of the standard solution under the above conditions, the relative standard deviation of the ratio of the peak area of clobetasol propionate to that of the internal standard is not more than 1.0%.

Containers and storage Containers—Tight containers.

Storage—Light-resistant.

Clozapramine Hydrochloride Hydrate

クロカプラミン塩酸塩水和物

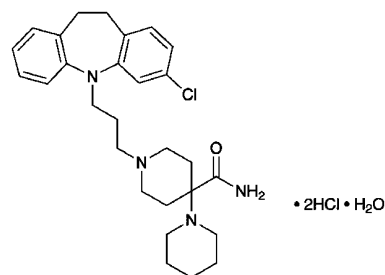

$\text{C}_{28}\text{H}_{37}\text{ClN}_4\text{O} \cdot 2\text{HCl} \cdot \text{H}_2\text{O}$: 572.01

1'-[3-(3-Chloro-10,11-dihydro-5H-dibenz[b,f]azepin-5-yl)propyl]-1,4'-bipiperidine-4'-carboxamide dihydrochloride monohydrate
[60789-62-0]

Clocapramine Hydrochloride Hydrate, when dried, contains not less than 98.0% of clocapramine hydrochloride ($C_{28}H_{37}ClN_4O \cdot 2HCl$; 553.99).

Description Clocapramine Hydrochloride Hydrate occurs as white, crystals or crystalline powder. It is odorless, and has a bitter taste.

It is freely soluble in acetic acid (100), sparingly soluble in water and in methanol, slightly soluble in ethanol (95), in chloroform and in isopropylamine, and practically insoluble in acetic anhydride and in diethyl ether.

It is gradually colored by light.

Melting point: about 260°C (with decomposition, after drying).

Identification (1) To 5 mL of a solution of Clocapramine Hydrochloride Hydrate (1 in 2500) add 1 mL of nitric acid: a blue color develops at first, and rapidly changes to deep blue, and then changes to green to yellow-green.

(2) Determine the absorption spectrum of a solution of Clocapramine Hydrochloride Hydrate in methanol (1 in 40,000) as directed under Ultraviolet-visible Spectrophotometry <2.24>, and compare the spectrum with the Reference Spectrum: both spectra exhibit similar intensities of absorption at the same wavelengths.

(3) Determine the infrared absorption spectrum of Clocapramine Hydrochloride Hydrate as directed in the potassium bromide disk method under Infrared Spectrophotometry <2.25>, and compare the spectrum with the Reference Spectrum: both spectra exhibit similar intensities of absorption at the same wave numbers.

(4) Dissolve 0.1 g of Clocapramine Hydrochloride Hydrate in 10 mL of water by warming, and after cooling, add 2 mL of ammonia TS, and filter. Acidify the filtrate with dilute nitric acid: the solution responds to Qualitative Tests <1.09> (2) for chloride.

Purity (1) Sulfate <1.14>—Dissolve 0.5 g of Clocapramine Hydrochloride Hydrate in 40 mL of water by warming, after cooling, and add 1 mL of dilute hydrochloric acid and water to make 50 mL. Perform the test using this solution as the test solution. Prepare the control solution with 0.50 mL of 0.005 mol/L sulfuric acid VS (not more than 0.048%).

(2) Heavy metals <1.07>—Proceed with 2.0 g of Clocapramine Hydrochloride Hydrate according to Method 2, and perform the test. Prepare the control solution with 2.0 mL of Standard Lead Solution (not more than 10 ppm).

(3) Related substances—Conduct this procedure without exposure to light, using light-resistant vessels. Dissolve 0.10 g of Clocapramine Hydrochloride Hydrate in 10 mL of a mixture of chloroform and isopropylamine (99:1), and use this solution as the sample solution. Pipet 1 mL of the sample solution, add a mixture of chloroform and isopropylamine (99:1) to make exactly 100 mL, and use this solution as the standard solution. Perform the test with these solutions as directed under Thin-layer Chromatography <2.03>. Spot 10 μ L each of the sample solution and standard solution on a plate of silica gel with fluorescent indicator for thin-layer chromatography. Develop the plate with a mixture of diethyl ether, ethyl acetate, methanol and ammonia solution (28) (100:70:40:1) to a distance of about 10 cm, and air-dry the plate. Examine under ultraviolet light (main wavelength: 254 nm): the spots other than the principal spot obtained from the sample solution are not more intense than the spot from the standard solution.

Loss on drying <2.41> 2.0 – 3.5% (0.5 g, in vacuum at a pressure not exceeding 0.67 kPa, phosphorus (V) oxide, 105°C, 4 hours).

Residue on ignition <2.44> Not more than 0.1% (1 g).

Assay Weigh accurately about 0.5 g of Clocapramine Hydrochloride Hydrate, previously dried, dissolve in 70 mL of a mixture of acetic anhydride and acetic acid (100) (6:1), and titrate <2.50> with 0.1 mol/L perchloric acid VS (potentiometric titration). Perform a blank determination in the same manner, and make any necessary correction.

Each mL of 0.1 mol/L perchloric acid VS
= 27.70 mg of $C_{28}H_{37}ClN_4O \cdot 2HCl$

Containers and storage Containers—Tight containers.

Storage—Light-resistant.

Clofedanol Hydrochloride

クロフェダノール塩酸塩

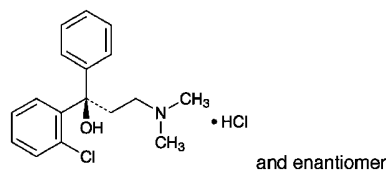

$C_{17}H_{20}ClNO \cdot HCl$: 326.26
(1*RS*)-1-(2-Chlorophenyl)-3-dimethylamino-1-phenylpropan-1-ol monohydrochloride
[511-13-7]

Clofedanol Hydrochloride, when dried, contains not less than 98.5% of clofedanol hydrochloride ($C_{17}H_{20}ClNO \cdot HCl$).

Description Clofedanol Hydrochloride occurs as white, crystals or crystalline powder.

It is freely soluble in methanol, in ethanol (95) and in acetic acid (100), sparingly soluble in water, and practically insoluble in diethyl ether.

A solution of Clofedanol Hydrochloride in methanol (1 in 20) does not show optical rotation.

Melting point: about 190°C (after drying, with decomposition).

Identification (1) Determine the absorption spectrum of a solution of Clofedanol Hydrochloride in 0.01 mol/L hydrochloric acid TS (1 in 2500) as directed under Ultraviolet-visible Spectrophotometry <2.24>, and compare the spectrum with the Reference Spectrum: both spectra exhibit similar intensities of absorption at the same wavelengths.

(2) Determine the infrared absorption spectrum of Clofedanol Hydrochloride, previously dried, as directed in the potassium bromide disk method under Infrared Spectrophotometry <2.25>, and compare the spectrum with the Reference Spectrum: both spectra exhibit similar intensities of absorption at the same wave numbers.

(3) A solution of Clofedanol Hydrochloride (1 in 100) responds to Qualitative Tests <1.09> for chloride.

Purity (1) Heavy metals <1.07>—Proceed with 2.0 g of Clofedanol Hydrochloride according to Method 2, and perform the test. Prepare the control solution with 2.0 mL of Standard Lead Solution (not more than 10 ppm).

(2) Related substances—Dissolve 0.05 g of Clofedanol Hydrochloride in 25 mL of methanol, and use this solution as the sample solution. Pipet 1 mL of the sample solution, add methanol to make exactly 100 mL, and use this solution as the standard solution. Perform the test with exactly 3 μ L

each of the sample solution and standard solution as directed under Liquid Chromatography <2.01> according to the following conditions. Determine each peak area of both solutions by the automatic integration method: the total area of the peaks other than clofedanol obtained from the sample solution is not larger than the peak area of clofedanol from the standard solution.

Operating conditions—

Detector: An ultraviolet absorption photometer (wavelength: 220 nm).

Column: A stainless steel column about 4 mm in inside diameter and about 15 cm in length, packed with octadecylsilylated silica gel for liquid chromatography (5 μm in particle diameter).

Column temperature: A constant temperature of about 40°C.

Mobile phase: Dissolve 1.34 g of potassium methanesulfonate in diluted phosphoric acid (1 in 1000) to make 1000 mL, and to 650 mL of this solution add 350 mL of methanol.

Flow rate: Adjust so that the retention time of clofedanol is about 9 minutes.

Selection of column: Dissolve 0.01 g each of Clofedanol Hydrochloride and ethyl parahydroxybenzoate in methanol to make 100 mL. Proceed with 3 μL of this solution under the above operating conditions, and calculate the resolution. Use a column giving elution of clofedanol and ethyl parahydroxybenzoate in this order with the resolution of these peaks being not less than 4.

Detection sensitivity: Adjust the detection sensitivity so that the peak height of clofedanol obtained from 3 μL of the standard solution composes between 20% and 50% of the full scale.

Time span of measurement: About three times as long as the retention time of clofedanol, beginning after the solvent peak.

Loss on drying <2.41> Not more than 2.0% (1 g, in vacuum, silica gel, 80°C, 3 hours).

Residue on ignition <2.44> Not more than 0.1% (1 g).

Assay Weigh accurately about 0.5 g of Clofedanol Hydrochloride, previously dried, dissolve in 15 mL of acetic acid (100), add 35 mL of acetic anhydride, and titrate <2.50> with 0.1 mol/L perchloric acid VS (potentiometric titration). Perform a blank determination in the same manner, and make any necessary correction.

Each mL of 0.1 mol/L perchloric acid VS
= 32.63 mg of C₁₇H₂₀ClNO.HCl

Containers and storage Containers—Tight containers.

Clofibrate

クロフィブラート

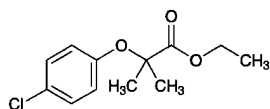

C₁₂H₁₅ClO₃: 242.70

Ethyl 2-(4-chlorophenoxy)-2-methylpropanoate
[637-07-0]

Clofibrate contains not less than 98.0% of clofibrate (C₁₂H₁₅ClO₃), calculated on the anhydrous

basis.

Description Clofibrate occurs as a colorless or light yellow, clear, oily liquid. It has a characteristic odor and taste, which is bitter at first, and subsequently sweet.

It is miscible with methanol, with ethanol (95), with ethanol (99.5), with diethyl ether and with hexane, and practically insoluble in water.

It is gradually decomposed by light.

Identification (1) Determine the absorption spectrum of a solution of Clofibrate in ethanol (99.5) (1 in 10,000) as directed under Ultraviolet-visible Spectrophotometry <2.24>, and compare the spectrum with the Reference Spectrum 1 or the spectrum of a solution of Clofibrate RS prepared in the same manner as the sample solution: both spectra exhibit similar intensities of absorption at the same wavelengths. Separately, determine the absorption spectrum of a solution of Clofibrate in ethanol (99.5) (1 in 100,000) as directed under Ultraviolet-visible Spectrophotometry <2.24>, and compare the spectrum with the Reference Spectrum 2 or the spectrum of a solution of Clofibrate RS prepared in the same manner as the sample solution: both spectra exhibit similar intensities of absorption at the same wavelengths.

(2) Determine the infrared absorption spectrum of Clofibrate as directed in the liquid film method under Infrared Spectrophotometry <2.25>, and compare the spectrum with the Reference Spectrum or the spectrum of Clofibrate RS: both spectra exhibit similar intensities of absorption at the same wave numbers.

Refractive index <2.45> n_D^{20} : 1.500 – 1.505

Specific gravity <2.56> d_4^{20} : 1.137 – 1.144

Purity (1) Acidity—Dissolve 2.0 g of Clofibrate in 100 mL of neutralized ethanol, and add 1 drop of phenolphthalein TS and 0.20 mL of 0.1 mol/L sodium hydroxide VS: the solution is red in color.

(2) Heavy metals <1.07>—Proceed with 2.0 g of Clofibrate according to Method 2, and perform the test. Prepare the control solution with 2.0 mL of Standard Lead Solution (not more than 10 ppm).

(3) Arsenic <1.11>—To 5.0 g of Clofibrate add 20 mL of nitric acid and 5 mL of sulfuric acid, and heat until white fumes are evolved. After cooling, if necessary, add further 5 mL of nitric acid, heat until white fumes are evolved, and repeat this procedure until the solution is colorless to light yellow. After cooling, add 15 mL of saturated ammonium oxalate solution, and heat again until white fumes are evolved. Cool, add water to make 25 mL, use 5 mL of this solution as the test solution, and perform the test.

Color standard: Prepare a solution according to the above procedure without using Clofibrate as the blank. Transfer 5 mL of the solution to a generator bottle, add 2.0 mL of Standard Arsenic Solution, and then proceed as directed in the test solution (not more than 20 ppm).

(4) p-Chlorophenol—To 1.0 g of Clofibrate add exactly 1 mL of the internal standard solution, then add the mobile phase to make 5 mL, and use this solution as the sample solution. Separately, dissolve 10 mg of 4-chlorophenol in a mixture of hexane and 2-propanol (9:1) to make exactly 100 mL. Pipet 10 mL of this solution, and add a mixture of hexane and 2-propanol (9:1) to make exactly 50 mL. Pipet 6 mL of this solution, add exactly 4 mL of the internal standard solution, then add the mobile phase to make 20 mL, and use this solution as the standard solution. Perform the test with 20 μL each of the sample solution and standard solution as directed under Liquid Chromatography <2.01> according

to the following conditions, and calculate the ratios, Q_T and Q_S , of the peak area of 4-chlorophenol to that of the internal standard: Q_T is not greater than Q_S .

Internal standard solution—A solution of 4-ethoxyphenol in the mobile phase (1 in 30,000).

Operating conditions—

Detector: An ultraviolet absorption photometer (wavelength: 275 nm).

Column: A stainless steel column about 4 mm in inside diameter and about 30 cm in length, packed with cyanopropylsilylated silica gel for liquid chromatography (5 to 10 μm in particle diameter).

Column temperature: A constant temperature of about 25°C.

Mobile phase: A mixture of hexane, 2-propanol and acetic acid (100) (1970:30:1).

Flow rate: Adjust so that the retention time of clofibrate is about 2 minutes.

Selection of column: Dissolve 10.0 g of Clofibrate, 6 mg of 4-chlorophenol and 6 mg of 4-ethoxyphenol in 1000 mL of hexane. Proceed with 20 μL of this solution under the above operating conditions, and calculate the resolution. Use a column giving elution of clofibrate, 4-chlorophenol and 4-ethoxyphenol in this order, with the resolution between the peaks of clofibrate and 4-chlorophenol is not less than 5, and with the resolution between the peaks of 4-chlorophenol and 4-ethoxyphenol is not less than 2.0.

Water <2.48> Not more than 0.2% (5 g, volumetric titration, direct titration).

Residue on ignition <2.44> Not more than 0.1% (1 g).

Assay Weigh accurately about 0.5 g of Clofibrate, add exactly 50 mL of 0.1 mol/L potassium hydroxide-ethanol VS, and heat in a water bath under a reflux condenser with a carbon dioxide absorbing tube (soda-lime) for 2 hours with frequent shaking. Cool, and titrate <2.50> immediately the excess potassium hydroxide with 0.1 mol/L hydrochloric acid VS (indicator: 3 drops of phenolphthalein TS). Perform a blank determination in the same manner.

Each mL of 0.1 mol/L potassium hydroxide-ethanol VS
= 24.27 mg of $\text{C}_{12}\text{H}_{15}\text{ClO}_3$

Containers and storage Containers—Tight containers.

Storage—Light-resistant.

Clofibrate Capsules

クロフィブラートカプセル

Clofibrate Capsules contain not less than 93.0% and not more than 107.0% of the labeled amount of clofibrate ($\text{C}_{12}\text{H}_{15}\text{ClO}_3$: 242.70).

Method of preparation Prepare as directed under Capsules, with Clofibrate.

Identification Cut and open Clofibrate Capsules, and use the contents as the sample. Determine the absorption spectrum of a solution of the sample in ethanol (99.5) (1 in 10,000) as directed under Ultraviolet-visible Spectrophotometry <2.24>: it exhibits a maximum between 278 nm and 282 nm, and it exhibits a maximum between 224 nm and 228 nm after diluting this solution 10 times with ethanol (99.5).

Purity *p*-Chlorophenol—Cut and open not less than 20 Clofibrate Capsules, and proceed with 1.0 g of the well-

mixed contents as directed in the Purity (4) under Clofibrate. **Internal standard solution**—A solution of 4-ethoxyphenol in the mobile phase (1 in 30,000).

Assay Weigh accurately not less than 20 Clofibrate Capsules, cut and open the capsules, rinse the inside of the capsules with a small amount of diethyl ether after taking out the contents, evaporate the diethyl ether by allowing the capsules to stand at room temperature, and weigh the capsules accurately. Weigh accurately an amount of the contents, equivalent to about 0.1 g of clofibrate ($\text{C}_{12}\text{H}_{15}\text{ClO}_3$), dissolve in acetonitrile to make exactly 100 mL. Pipet 5 mL of this solution, add exactly 5 mL of the internal standard solution, and use this solution as the sample solution. Separately, weigh accurately about 0.1 g of Clofibrate RS, proceed in the same manner as directed for the sample solution, and use the solution so obtained as the standard solution. Perform the test with 10 μL each of the sample solution and standard solution as directed under Liquid Chromatography <2.01> according to the following conditions, and calculate the ratios, Q_T and Q_S , of the peak area of clofibrate to that of the internal standard.

$$\begin{aligned} &\text{Amount (mg) of clofibrate (C}_{12}\text{H}_{15}\text{ClO}_3) \\ &= M_S \times Q_T/Q_S \end{aligned}$$

M_S : Amount (mg) of Clofibrate RS taken

Internal standard solution—A solution of ibuprofen in the mobile phase (1 in 100).

Operating conditions—

Detector: An ultraviolet absorption photometer (wavelength: 275 nm).

Column: A stainless steel column about 4 mm in inside diameter and about 30 cm in length, packed with octadecylsilylated silica gel for liquid chromatography (5 to 10 μm in particle diameter).

Column temperature: A constant temperature of about 25°C.

Mobile phase: A mixture of acetonitrile and diluted phosphoric acid (1 in 1000) (3:2).

Flow rate: Adjust so that the retention time of clofibrate is about 10 minutes.

Selection of column: Dissolve 0.05 g of clofibrate and 0.3 g of ibuprofen in 50 mL of acetonitrile. Proceed with 10 μL of this solution under the above operating conditions, and calculate the resolution. Use a column giving elution of ibuprofen and clofibrate in this order with the resolution between these peaks being not less than 6.

Containers and storage Containers—Well-closed containers.

Storage—Light-resistant.

Clomifene Citrate

クロミフェンクエン酸塩

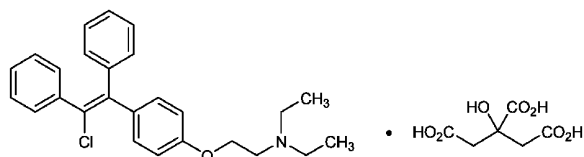

$C_{26}H_{28}ClNO \cdot C_6H_8O_7$; 598.08

2-[4-(2-Chloro-1,2-diphenylvinyl)phenoxy]-*N,N*-diethylethylamine monocitrate
[50-41-9]

Clomifene Citrate, when dried, contains not less than 98.0% of clomifene citrate ($C_{26}H_{28}ClNO \cdot C_6H_8O_7$).

Description Clomifene Citrate occurs as a white to pale yellow-white powder. It is odorless.

It is freely soluble in methanol and in acetic acid (100), sparingly soluble in ethanol (95), and practically insoluble in diethyl ether.

It gradually changes in color by light.

Melting point: about 115°C

Identification (1) To 2 mL of a solution of Clomifene Citrate in methanol (1 in 200) add 2 mL of Reinecke salt TS: a light red precipitate is produced.

(2) Determine the absorption spectrum of a solution of Clomifene Citrate in 0.1 mol/L hydrochloric acid TS (1 in 50,000) as directed under Ultraviolet-visible Spectrophotometry <2.24>, and compare the spectrum with the Reference Spectrum or the spectrum of a solution of Clomifene Citrate RS prepared in the same manner as the sample solution: both spectra exhibit similar intensities of absorption at the same wavelengths.

(3) A solution of Clomifene Citrate in methanol (1 in 200) responds to Qualitative Tests <1.09> (1) and (2) for citrate salt.

Purity (1) Clarity and color of solution—A solution of 1.0 g of Clomifene Citrate in 30 mL of methanol is clear and colorless.

(2) Heavy metals <1.07>—Proceed with 2.0 g of Clomifene Citrate according to Method 2, and perform the test. Prepare the control solution with 2.0 mL of Standard Lead Solution (not more than 10 ppm).

Loss on drying <2.41> Not more than 1.0% (1 g, in vacuum, phosphorus (V) oxide, 3 hours).

Residue on ignition <2.44> Not more than 0.1% (1 g).

Isomer ratio To 10 mg of Clomifene Citrate add 10 mL of water and 1 mL of sodium hydroxide TS, and shake to uniformly disperse. Add 10 mL of ethyl acetate, shake vigorously for 5 minutes, allow to stand for 5 minutes, and use the upper layer as the sample solution. Perform the test with 1 μ L of the sample solution as directed under Gas Chromatography <2.02> according to the following conditions. Determine the areas of two adjacent peaks, A_a and A_b , having the retention time of about 8 minutes, where A_a is the peak area of shorter retention time and A_b is the peak area of longer retention time: $A_b/(A_a + A_b)$ is between 0.3 and 0.5.

Operating conditions—

Detector: A hydrogen flame-ionization detector.

Column: A fused silica column 0.25 mm in inside diameter

and 15 m in length, coated the inside surface with a layer about 0.1 μ m thick of dimethylpolysiloxane for gas chromatography.

Column temperature: A constant temperature of about 230°C.

Injection port temperature: A constant temperature of about 270°C.

Detector temperature: A constant temperature of about 300°C.

Carrier gas: Helium.

Flow rate: Adjust so that the retention time of the first peak of clomifene citrate is about 7.5 minutes.

Split ratio: 1:50.

System suitability—

System performance: When the procedure is run with 1 μ L of the sample solution under the above operating conditions, the resolution between the two adjacent peaks having the retention time of about 8 minutes is not less than 5.

System repeatability: When the test is repeated 6 times with 1 μ L of the sample solution under the above operating conditions, the relative standard deviation of the result of $A_b/(A_a + A_b)$ is not more than 1.0%.

Assay Weigh accurately about 1 g of Clomifene Citrate, previously dried, dissolve in 50 mL of acetic acid (100), and titrate <2.50> with 0.1 mol/L perchloric acid VS (indicator: 2 drops of crystal violet TS). Perform a blank determination in the same manner, and make any necessary correction.

Each mL of 0.1 mol/L perchloric acid VS
= 59.81 mg of $C_{26}H_{28}ClNO \cdot C_6H_8O_7$

Containers and storage Containers—Tight containers.

Storage—Light-resistant.

Clomifene Citrate Tablets

クロミフェンクエン酸塩錠

Clomifene Citrate Tablets contain not less than 93.0% and not more than 107.0% of the labeled amount of the clomifene citrate ($C_{26}H_{28}ClNO \cdot C_6H_8O_7$; 598.08).

Method of preparation Prepare as directed under Tablets, with Clomifene Citrate.

Identification Weigh a portion of powdered Clomifene Citrate Tablets, equivalent to 50 mg of Clomifene Citrate, shake vigorously with 50 mL of methanol for 10 minutes, centrifuge, and use the supernatant liquid as the sample solution. Separately, dissolve 10 mg of Clomifene Citrate RS in 10 mL of methanol, and use this solution as the standard solution. Perform the test with these solutions as directed under Thin-layer Chromatography <2.03>. Spot 10 μ L each of the sample solution and standard solution on a plate of silica gel with fluorescent indicator for thin-layer chromatography. Develop the plate with a mixture of 2-propanol, toluene and diethylamine (10:10:1) to a distance of about 10 cm, and air-dry the plate. Examine under ultraviolet light (main wavelength: 254 nm): the spots from the sample solution and standard solution show the same R_f value.

Uniformity of dosage units <6.02> Perform the test according to the following method: it meets the requirement of the Content uniformity test.

To 1 tablet of Clomifene Citrate Tablets add 10 mL of water, and shake until the tablets are disintegrated. To this

solution add 50 mL of methanol, shake for 10 minutes, and add methanol to make exactly 100 mL. Centrifuge this solution, pipet 4 mL of the supernatant liquid, add methanol to make exactly V mL so that each mL contains about 20 μg of clomifene citrate ($\text{C}_{26}\text{H}_{28}\text{ClNO}\cdot\text{C}_6\text{H}_8\text{O}_7$), and use this solution as the sample solution. Proceed as directed in the Assay.

$$\begin{aligned} \text{Amount (mg) of clomifene citrate } (\text{C}_{26}\text{H}_{28}\text{ClNO}\cdot\text{C}_6\text{H}_8\text{O}_7) \\ = M_S \times A_T/A_S \times V/100 \end{aligned}$$

M_S : Amount (mg) of Clomifene Citrate RS taken

Dissolution <6.10> When the test is performed at 50 revolutions per minute according to the Paddle method, using 900 mL of 1st fluid for dissolution test as the dissolution medium, the dissolution rate in 30 minutes of Clomifene Citrate Tablets is not less than 80%.

Start the test with 1 tablet of Clomifene Citrate Tablets, withdraw not less than 20 mL of the medium at the specified minute after starting the test, and filter through a membrane filter with a pore size not exceeding 0.45 μm . Discard not less than 10 mL of the first filtrate, pipet V mL of the subsequent filtrate, add the dissolution medium to make exactly V' mL so that each mL contains about 28 μg of clomifene citrate ($\text{C}_{26}\text{H}_{28}\text{ClNO}\cdot\text{C}_6\text{H}_8\text{O}_7$), and use this solution as the sample solution. Separately, weigh accurately about 28 mg of Clomifene Citrate RS, previously dried in vacuum using phosphorus (V) oxide as a desiccant for 3 hours, and dissolve in methanol to make exactly 50 mL. Pipet 5 mL of this solution, add the dissolution medium to make exactly 100 mL, and use this solution as the standard solution. Determine the absorbances, A_T and A_S , at 291 nm of the sample solution and standard solution as directed under Ultraviolet-visible Spectrophotometry <2.24>, using the dissolution medium as the blank.

$$\begin{aligned} \text{Dissolution rate (\%)} \text{ with respect to the labeled amount} \\ \text{of clomifene citrate } (\text{C}_{26}\text{H}_{28}\text{ClNO}\cdot\text{C}_6\text{H}_8\text{O}_7) \\ = M_S \times A_T/A_S \times V'/V \times 1/C \times 90 \end{aligned}$$

M_S : Amount (mg) of Clomifene Citrate RS taken

C : Labeled amount (mg) of clomifene citrate ($\text{C}_{26}\text{H}_{28}\text{ClNO}\cdot\text{C}_6\text{H}_8\text{O}_7$) in 1 tablet

Assay Weigh accurately, and powder not less than 20 Clomifene Citrate Tablets. Weigh accurately a portion of the powder, equivalent to about 50 mg of clomifene citrate ($\text{C}_{26}\text{H}_{28}\text{ClNO}\cdot\text{C}_6\text{H}_8\text{O}_7$), add 50 mL of methanol, shake for 10 minutes, and add methanol to make exactly 100 mL. Centrifuge a portion of this solution, pipet 4 mL of the supernatant liquid, add methanol to make exactly 100 mL, and use this solution as the sample solution. Separately, weigh accurately about 50 mg of Clomifene Citrate RS, previously dried in a desiccator (in vacuum, phosphorus (V) oxide) for 3 hours, and dissolve in methanol to make exactly 100 mL. Pipet 4 mL of this solution, and dilute with methanol to make exactly 100 mL, and use this solution as the standard solution. Determine the absorbances, A_T and A_S , of the sample solution and the standard solution, respectively, at 295 nm as directed under Ultraviolet-visible Spectrophotometry <2.24>.

$$\begin{aligned} \text{Amount (mg) of clomifene citrate } (\text{C}_{26}\text{H}_{28}\text{ClNO}\cdot\text{C}_6\text{H}_8\text{O}_7) \\ = M_S \times A_T/A_S \end{aligned}$$

M_S : Amount (mg) of Clomifene Citrate RS taken

Containers and storage Containers—Tight containers.

Clomipramine Hydrochloride

クロミプラミン塩酸塩

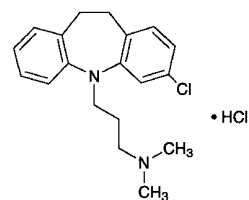

$\text{C}_{19}\text{H}_{23}\text{ClN}_2\cdot\text{HCl}$: 351.31

3-(3-Chloro-10,11-dihydro-5*H*-dibenz[*b,f*]azepin-5-yl)-*N,N*-dimethylpropylamine monohydrochloride
[17321-77-6]

Clomipramine Hydrochloride, when dried, contains not less than 98.5% of clomipramine hydrochloride ($\text{C}_{19}\text{H}_{23}\text{ClN}_2\cdot\text{HCl}$).

Description Clomipramine Hydrochloride occurs as a white to pale yellow, crystalline powder. It is odorless.

It is very soluble in acetic acid (100), freely soluble in water, in methanol and in chloroform, soluble in ethanol (95), sparingly soluble in acetic anhydride, slightly soluble in acetone, and practically insoluble in ethyl acetate and in diethyl ether.

Identification (1) Dissolve 3 mg of Clomipramine Hydrochloride in 1 mL of nitric acid: a deep blue color develops.

(2) Determine the absorption spectrum of a solution of Clomipramine Hydrochloride in 0.1 mol/L hydrochloric acid TS (3 in 100,000) as directed under Ultraviolet-visible Spectrophotometry <2.24>, and compare the spectrum with the Reference Spectrum: both spectra exhibit similar intensities of absorption at the same wavelengths.

(3) Take 1 g of Clomipramine Hydrochloride in a separator, dissolve in 10 mL of water, add 5 mL of sodium hydroxide TS, and extract with two 30-mL portions of diethyl ether [the water layer is used for Identification (4)]. Combine the diethyl ether extracts, add 20 mL of water, and shake. Take diethyl ether layer, dry with a small portion of anhydrous sodium sulfate, and filter. Evaporate the combined extracts by warming on a water bath, and proceed the test with the residue as directed under Flame Coloration Test <1.04> (2): a green color appears.

(4) The solution neutralized by adding dilute nitric acid to the water layer obtained in (3) responds to Qualitative Tests <1.09> for chloride.

pH <2.54> Dissolve 1.0 g of Clomipramine Hydrochloride in 10 mL of water: the pH of this solution is between 3.5 and 5.0.

Melting point <2.60> 192 – 196°C

Purity (1) Clarity and color of solution—Dissolve 1.0 g of Clomipramine Hydrochloride in 10 mL of water: the solution is clear and colorless to pale yellow.

(2) Heavy metals <1.07>—Proceed with 2.0 g of Clomipramine Hydrochloride according to Method 2, and perform the test. Prepare the control solution with 2.0 mL of Standard Lead Solution (not more than 10 ppm).

(3) Arsenic <1.11>—Prepare the test solution with 1.0 g of Clomipramine Hydrochloride according to Method 3, and perform the test (not more than 2 ppm).

(4) Related substances—Dissolve 0.20 g of Clomipramine Hydrochloride in 10 mL of methanol, and use this so-

lution as the sample solution. Separately, weigh 20 mg of Imipramine Hydrochloride, dissolve in methanol to make exactly 100 mL, and use this solution as the standard solution (1). Then pipet 1 mL of the sample solution, and add methanol to make exactly 50 mL. Pipet 5 mL of the solution, add methanol to make exactly 50 mL, and use this solution as the standard solution (2). Perform the test with these solutions as directed under Thin-layer Chromatography <2.03>. Spot 5 μ L each of the sample solution and standard solutions (1) and (2) on a plate of silica gel for thin-layer chromatography. Develop the plate with a mixture of ethyl acetate, acetone and ammonia solution (28) (15:5:1) to a distance of about 10 cm, and air-dry the plate. Spray evenly potassium dichromate-sulfuric acid TS on the plate: the spot obtained from the sample solution, corresponding to that from the standard solution (1), is not more intense than the spot from the standard solution (1). Each of the spots other than the principal spot and the spot mentioned above from the sample solution is not more intense than the spot from the standard solution (2).

Loss on drying <2.41> Not more than 0.5% (1 g, 105°C, 3 hours).

Residue on ignition <2.44> Not more than 0.1% (1 g).

Assay Weigh accurately about 0.5 g of Clomipramine Hydrochloride, previously dried, dissolve in 50 mL of a mixture of acetic anhydride and acetic acid (100) (7:3), and titrate <2.50> with 0.1 mol/L perchloric acid VS (potentiometric titration). Perform a blank determination in the same manner, and make any necessary correction.

$$\begin{aligned} \text{Each mL of 0.1 mol/L perchloric acid VS} \\ = 35.13 \text{ mg of } C_{19}H_{23}ClN_2.HCl \end{aligned}$$

Containers and storage Containers—Well-closed containers.

Storage—Light-resistant.

Clomipramine Hydrochloride Tablets

クロミプラミン塩酸塩錠

Clomipramine Hydrochloride Tablets contain not less than 92.0% and not more than 108.0% of the labeled amount of clomipramine hydrochloride ($C_{19}H_{23}ClN_2.HCl$: 351.31).

Method of preparation Prepare as directed under Tablets, with Clomipramine Hydrochloride.

Identification To a portion of powdered Clomipramine Hydrochloride Tablets, equivalent to 50 mg of Clomipramine Hydrochloride, add a suitable amount of 0.1 mol/L hydrochloric acid TS, shake thoroughly, and add 0.1 mol/L hydrochloric acid TS to make 250 mL. Centrifuge this solution, and to 10 mL of the supernatant liquid add 0.1 mol/L hydrochloric acid TS to make 100 mL. Determine the absorption spectrum of this solution as directed under Ultraviolet-visible Spectrophotometry <2.24>: it exhibits a maximum between 250 nm and 254 nm.

Uniformity of dosage unit <6.02> Perform the test according to the following method: it meets the requirement of the Content uniformity test.

To 1 tablet of Clomipramine Hydrochloride Tablets add $V/5$ mL of a mixture of methanol and 0.1 mol/L hydrochloric

acid TS (3:1), sonicate to disintegrate the tablet, and shake thoroughly for 30 minutes. To this solution add $3V/5$ mL of methanol, shake for 15 minutes, and add methanol to make exactly V mL so that each mL contains about 0.1 mg of clomipramine hydrochloride ($C_{19}H_{23}ClN_2.HCl$). Centrifuge this solution, and use the supernatant liquid as the sample solution. Then, proceed as directed in the Assay.

$$\begin{aligned} \text{Amount (mg) of clomipramine hydrochloride} \\ (C_{19}H_{23}ClN_2.HCl) \\ = M_S \times A_T/A_S \times V/250 \end{aligned}$$

M_S : Amount (mg) of clomipramine hydrochloride for assay taken

Dissolution <6.10> When the test is performed at 50 revolutions per minute according to the Paddle method, using 900 mL of water as the dissolution medium, the dissolution rates in 45 minutes of 10-mg tablet and in 90 minutes of 25-mg tablet are not less than 80%, respectively.

Start the test with 1 tablet of Clomipramine Hydrochloride Tablets, withdraw not less than 20 mL of the medium at the specified minute after starting the test, and filter through a membrane filter with a pore size not exceeding 0.45 μ m. Discard not less than 10 mL of the first filtrate, pipet V mL of the subsequent filtrate, add water to make exactly V' mL so that each mL contains about 11 μ g of clomipramine hydrochloride ($C_{19}H_{23}ClN_2.HCl$), and use this solution as the sample solution. Separately, weigh accurately about 28 mg of clomipramine hydrochloride for assay, previously dried at 105°C for 3 hours, and dissolve in water to make exactly 100 mL. Pipet 4 mL of this solution, add water to make exactly 100 mL, and use this solution as the standard solution. Determine the absorbances, A_T and A_S , of the sample solution and standard solution at 252 nm as directed under Ultraviolet-visible Spectrophotometry <2.24>.

$$\begin{aligned} \text{Dissolution rate (\%)} \text{ with respect to the labeled amount} \\ \text{of clomipramine hydrochloride } (C_{19}H_{23}ClN_2.HCl) \\ = M_S \times A_T/A_S \times V'/V \times 1/C \times 36 \end{aligned}$$

M_S : Amount (mg) of clomipramine hydrochloride for assay taken

C : Labeled amount (mg) of clomipramine hydrochloride ($C_{19}H_{23}ClN_2.HCl$) in 1 tablet

Assay Weigh accurately the mass of not less than 20 Clomipramine Hydrochloride Tablets, and powder. Weigh accurately a portion of the powder, equivalent to about 25 mg of clomipramine hydrochloride ($C_{19}H_{23}ClN_2.HCl$), add 50 mL of a mixture of methanol and 0.1 mol/L hydrochloric acid TS (3:1), sonicate, and shake thoroughly for 30 minutes. To this solution add 150 mL of methanol, shake for 15 minutes, and add methanol to make exactly 250 mL. Centrifuge this solution, and use the supernatant liquid as the sample solution. Separately, weigh accurately about 25 mg of clomipramine hydrochloride for assay, previously dried at 105°C for 3 hours, dissolve in 50 mL of a mixture of methanol and 0.1 mol/L hydrochloric acid TS (3:1), add methanol to make exactly 250 mL, and use this solution as the standard solution. Perform the test with exactly 20 μ L each of the sample solution and standard solution as directed under Liquid Chromatography <2.01> according to the following conditions, and determine the peak areas, A_T and A_S , of clomipramine in each solution.

$$\begin{aligned} \text{Amount (mg) of clomipramine hydrochloride} \\ (C_{19}H_{23}ClN_2.HCl) \\ = M_S \times A_T/A_S \end{aligned}$$

M_S : Amount (mg) of clomipramine hydrochloride for

assay taken

Operating conditions—

Detector: An ultraviolet absorption photometer (wavelength: 254 nm).

Column: A stainless steel column 4.6 mm in inside diameter and 25 cm in length, packed with octadecylsilanized silica gel for liquid chromatography (10 μm in particle diameter).

Column temperature: A constant temperature of about 25°C.

Mobile phase: Dissolve 2 g of sodium 1-octanesulfonate in 300 mL of water, and add 450 mL of methanol, 250 mL of acetonitrile and 1 mL of 0.5 mol/L sulfuric acid TS.

Flow rate: Adjust so that the retention time of clomipramine is about 13 minutes.

System suitability—

System performance: When the procedure is run with 20 μL of the standard solution under the above operating conditions, the number of theoretical plates and the symmetry factor of the peak of clomipramine are not less than 3000 and not more than 1.5, respectively.

System repeatability: When the test is repeated 6 times with 20 μL of the standard solution under the above operating conditions, the relative standard deviation of the peak area of clomipramine is not more than 1.0%.

Containers and storage Containers—Tight containers.

Clonazepam

クロナゼパム

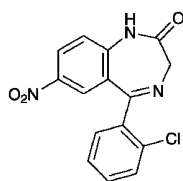

C₁₅H₁₀ClN₃O₃; 315.71

5-(2-Chlorophenyl)-7-nitro-1,3-dihydro-2H-1,4-benzodiazepin-2-one

[1622-61-3]

Clonazepam, when dried, contains not less than 99.0% of clonazepam (C₁₅H₁₀ClN₃O₃).

Description Clonazepam occurs as white to light yellow, crystals or crystalline powder.

It is sparingly soluble in acetic anhydride and in acetone, slightly soluble in methanol and in ethanol (95), very slightly soluble in diethyl ether, and practically insoluble in water.

It is gradually colored by light.

Melting point: about 240°C (with decomposition).

Identification (1) Determine the absorption spectrum of a solution of Clonazepam in methanol (1 in 100,000) as directed under Ultraviolet-visible Spectrophotometry <2.24>, and compare the spectrum with the Reference Spectrum: both spectra exhibit similar intensities of absorption at the same wavelengths.

(2) Determine the infrared absorption spectrum of Clonazepam, previously dried, as directed in the potassium bromide disk method under Infrared Spectrophotometry <2.25>, and compare the spectrum with the Reference Spectrum: both spectra exhibit similar intensities of absorption at the same wave numbers.

(3) Perform the test with Clonazepam as directed under

Flame Coloration Test <1.04> (2): a green color appears.

Purity (1) Chloride <1.03>—To 1.0 g of Clonazepam add 50 mL of water, allow to stand for 1 hour with occasional shaking, and filter. Discard the first 20 mL portion of the filtrate, take the subsequent 20 mL portion of the filtrate, and add 6 mL of dilute nitric acid and water to make 50 mL. Use this solution as the test solution, and perform the test. Prepare the control solution as follows: to 0.25 mL of 0.01 mol/L hydrochloric acid VS add 6 mL of dilute nitric acid and water to make 50 mL (not more than 0.022%).

(2) Heavy metals <1.07>—Proceed with 1.0 g of Clonazepam according to Method 4, and perform the test. Prepare the control solution with 2.0 mL of Standard Lead Solution (not more than 20 ppm).

(3) Related substances—Dissolve 0.25 g of Clonazepam in 10 mL of acetone, and use this solution as the sample solution. Pipet 1 mL of the sample solution, add acetone to make exactly 100 mL, then pipet 1 mL of this solution, add acetone to make exactly 10 mL, and use this solution as the standard solution. Perform the test with these solutions as directed under Thin-layer Chromatography <2.03>. Spot 10 μL each of the sample solution and standard solution on a plate of silica gel with fluorescent indicator for thin-layer chromatography. Develop the plate with a mixture of nitromethane and acetone (10:1) to a distance of about 12 cm, and air-dry the plate. Examine under ultraviolet light (main wavelength: 254 nm): the spots other than the principal spot obtained from the sample solution are not more intense than the spot from the standard solution.

Loss on drying <2.41> Not more than 0.30% (1 g, 105°C, 4 hours).

Residue on ignition <2.44> Not more than 0.1% (1 g).

Assay Weigh accurately about 0.5 g of Clonazepam, previously dried, dissolve in 70 mL of acetic anhydride, and titrate <2.50> with 0.1 mol/L perchloric acid VS (potentiometric titration). Perform a blank determination in the same manner, and make any necessary correction.

Each mL of 0.1 mol/L perchloric acid VS
= 31.57 mg of C₁₅H₁₀ClN₃O₃

Containers and storage Containers—Well-closed containers.

Storage—Light-resistant.

Clonazepam Fine Granules

クロナゼパム細粒

Clonazepam Fine Granules contain not less than 95.0% and not more than 105.0% of the labeled amount of clonazepam (C₁₅H₁₀ClN₃O₃; 315.71).

Method of preparation Prepare as directed under Granules, with Clonazepam.

Identification Powder Clonazepam Fine Granules. To a portion of the powder, equivalent to 1 mg of Clonazepam, add an appropriate volume of methanol and shake for 10 minutes, add methanol to make 100 mL, and filter. Determine the absorption spectrum of the filtrate as directed under Ultraviolet-visible Spectrophotometry <2.24>: it exhibits a maximum between 307 nm and 311 nm.

Dissolution Being specified separately when the drug is granted approval based on the Law.

Assay Powder Clonazepam Fine Granules. Weigh accurately a portion of the powder, equivalent to about 2.4 mg of clonazepam ($C_{15}H_{10}ClN_3O_3$), add exactly 30 mL of a mixture of methanol and water (7:3), and shake for 15 minutes. Centrifuge this solution, pipet 5 mL of the supernatant liquid, add a mixture of methanol and water (7:3) to make exactly 20 mL, and use this solution as the sample solution. Separately, weigh accurately about 20 mg of clonazepam for assay, previously dried at 105°C for 4 hours, dissolve in methanol to make exactly 50 mL. Pipet 5 mL of this solution, add a mixture of methanol and water (7:3) to make exactly 100 mL, and use this solution as the standard solution. Perform the test with exactly 15 μ L each of the sample solution and standard solution as directed under Liquid Chromatography <2.01> according to the following conditions, and determine the peak areas, A_T and A_S , of clonazepam in each solution.

$$\begin{aligned} & \text{Amount (mg) of clonazepam } (C_{15}H_{10}ClN_3O_3) \\ & = M_S \times A_T/A_S \times 3/25 \end{aligned}$$

M_S : Amount (mg) of clonazepam for assay taken

Operating conditions—

Detector: An ultraviolet absorption photometer (wavelength: 310 nm).

Column: A stainless steel column 4.6 mm in inside diameter and 15 cm in length, packed with octadecylsilanized silica gel for liquid chromatography (5 μ m in particle diameter).

Column temperature: A constant temperature of about 25°C.

Mobile phase: A mixture of water, acetonitrile and methanol (4:3:3).

Flow rate: Adjust so that the retention time of clonazepam is about 5 minutes.

System suitability—

System performance: When the procedure is run with 15 μ L of the standard solution under the above operating conditions, the number of theoretical plates and the symmetry factor of the peak of clonazepam are not less than 3000 and not more than 1.5, respectively.

System repeatability: When the test is repeated 6 times with 15 μ L of the standard solution under the above operating conditions, the relative standard deviation of the peak area of clonazepam is not more than 1.0%.

Containers and storage Containers—Tight containers.

Storage—Light-resistant.

Clonazepam Tablets

クロナゼパム錠

Clonazepam Tablets contain not less than 95.0% and not more than 105.0% of the labeled amount of clonazepam ($C_{15}H_{10}ClN_3O_3$; 315.71).

Method of preparation Prepare as directed under Tablets, with Clonazepam.

Identification Powder Clonazepam Tablets. To a portion of the powder, equivalent to 1 mg of Clonazepam, add an appropriate volume of methanol and shake for 10 minutes, then add methanol to make 100 mL, and filter. Determine the absorption spectrum of the filtrate as directed under Ultraviolet-visible Spectrophotometry <2.24>: it exhibits a maximum between 307 nm and 311 nm.

Uniformity of dosage units <6.02> Perform the test accord-

ing to the following method: it meets the requirement of the Content uniformity test.

To 1 tablet of Clonazepam Tablets, add $V/10$ mL of methanol, shake for 15 minutes, add 2-propanol to make exactly V mL so that each mL contains about 10 μ g of clonazepam ($C_{15}H_{10}ClN_3O_3$). Filter this solution through a membrane filter with a pore size not exceeding 0.45 μ m. Discard the first 10 mL of the filtrate, and use the subsequent filtrate as the sample solution. Separately, weigh accurately about 20 mg of clonazepam for assay, previously dried at 105°C for 4 hours, dissolve in methanol to make exactly 200 mL. Pipet 10 mL of this solution, add 2-propanol to make exactly 100 mL, and use this solution as the standard solution. Determine the absorbances, A_T and A_S , at 312 nm of the sample solution and standard solution as directed under Ultraviolet-visible Spectrophotometry <2.24>, using a mixture of 2-propanol and methanol (9:1) as the control.

$$\begin{aligned} & \text{Amount (mg) of clonazepam } (C_{15}H_{10}ClN_3O_3) \\ & = M_S \times A_T/A_S \times V/2000 \end{aligned}$$

M_S : Amount (mg) of clonazepam for assay taken

Dissolution <6.10> When the test is performed at 50 revolutions per minute according to the Paddle method, using 900 mL of water as the dissolution medium, the dissolution rate in 30 minutes of 0.5-mg tablet and 1-mg tablet is not less than 80%, and that of 2-mg tablet is not less than 75%.

Start the test with 1 tablet of Clonazepam Tablets, withdraw not less than 20 mL of the medium at the specified minute after starting the test, and filter through a membrane filter with a pore size not exceeding 0.45 μ m. Discard not less than 10 mL of the first filtrate, pipet V mL of the subsequent filtrate, add water to make exactly V' mL so that each mL contains about 0.56 μ g of clonazepam ($C_{15}H_{10}ClN_3O_3$), and use this solution as the sample solution. Separately, weigh accurately about 22 mg of clonazepam for assay, previously dried at 105°C for 4 hours, and dissolve in methanol to make exactly 100 mL. Pipet 5 mL of this solution, and add methanol to make exactly 50 mL. Pipet 5 mL of this solution and add water to make exactly 200 mL, and use this solution as the standard solution. Perform the test with exactly 100 μ L each of the sample solution and standard solution as directed under Liquid Chromatography <2.01> according to the following conditions, and determine the peak areas, A_T and A_S , of clonazepam in each solution.

$$\begin{aligned} & \text{Dissolution rate (\%)} \text{ with respect to the labeled amount} \\ & \text{of clonazepam } (C_{15}H_{10}ClN_3O_3) \\ & = M_S \times A_T/A_S \times V'/V \times 1/C \times 9/4 \end{aligned}$$

M_S : Amount (mg) of clonazepam for assay taken

C : Labeled amount (mg) of clonazepam ($C_{15}H_{10}ClN_3O_3$) in 1 tablet

Operating conditions—

Proceed as directed in the operating conditions in the Assay.

System suitability—

System performance: When the procedure is run with 100 μ L of the standard solution under the above operating conditions, the number of theoretical plates and the symmetry factor of the peak of clonazepam are not less than 2000 and not more than 2.0, respectively.

System repeatability: When the test is repeated 6 times with 100 μ L of the standard solution under the above operating conditions, the relative standard deviation of the peak area of clonazepam is not more than 2.0%.

Assay Weigh accurately the mass of not less than 20

Clonazepam Tablets, and powder. Weigh accurately a portion of the powder, equivalent to about 2.5 mg of clonazepam ($C_{15}H_{10}ClN_3O_3$), add exactly 50 mL of a mixture of methanol and water (7:3), and shake for 15 minutes. Centrifuge this solution, and use the supernatant liquid as the sample solution. Separately, weigh accurately about 25 mg of clonazepam for assay, previously dried at 105°C for 4 hours, dissolve in methanol to make exactly 25 mL. Pipet 5 mL of this solution, add a mixture of methanol and water (7:3) to make exactly 100 mL, and use this solution as the standard solution. Perform the test with exactly 10 μ L each of the sample solution and standard solution as directed under Liquid Chromatography <2.01> according to the following conditions, and determine the peak areas, A_T and A_S , of clonazepam in each solution.

$$\begin{aligned} &\text{Amount (mg) of clonazepam (C}_{15}\text{H}_{10}\text{ClN}_3\text{O}_3) \\ &= M_S \times A_T / A_S \times 1/10 \end{aligned}$$

M_S : Amount (mg) of clonazepam for assay taken

Operating conditions—

Detector: An ultraviolet absorption photometer (wavelength: 310 nm).

Column: A stainless steel column 4.6 mm in inside diameter and 15 cm in length, packed with octadecylsilylated silica gel for liquid chromatography (5 μ m in particle diameter).

Column temperature: A constant temperature of about 25°C.

Mobile phase: A mixture of water, acetonitrile and methanol (4:3:3).

Flow rate: Adjust so that the retention time of clonazepam is about 5 minutes.

System suitability—

System performance: When the procedure is run with 10 μ L of the standard solution under the above operating conditions, the number of theoretical plates and the symmetry factor of the peak of clonazepam are not less than 3000 and not more than 1.5, respectively.

System repeatability: When the test is repeated 6 times with 10 μ L of the standard solution under the above operating conditions, the relative standard deviation of the peak area of clonazepam is not more than 1.0%.

Containers and storage Containers—Tight containers.

Storage—Light-resistant.

Clonidine Hydrochloride

クロニジン塩酸塩

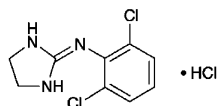

$C_9H_9Cl_2N_3 \cdot HCl$: 266.55

2-(2,6-Dichlorophenylimino)imidazolidine monohydrochloride
[4205-91-8]

Clonidine Hydrochloride, when dried, contains not less than 99.0% of clonidine hydrochloride ($C_9H_9Cl_2N_3 \cdot HCl$).

Description Clonidine Hydrochloride occurs as white, crystals or crystalline powder.

It is freely soluble in methanol, soluble in water and in ethanol (95), slightly soluble in acetic acid (100), and practi-

cally insoluble in acetic anhydride and in diethyl ether.

Identification (1) To 5 mL of a solution of Clonidine Hydrochloride (1 in 1000) add 6 drops of Dragendorff's TS: an orange precipitate is formed.

(2) Determine the absorption spectrum of a solution of Clonidine Hydrochloride in 0.01 mol/L hydrochloric acid TS (3 in 10,000) as directed under Ultraviolet-visible Spectrophotometry <2.24>, and compare the spectrum with the Reference Spectrum: both spectra exhibit similar intensities of absorption at the same wavelengths.

(3) Determine the infrared absorption spectrum of Clonidine Hydrochloride, previously dried, as directed in the potassium chloride disk method under Infrared Spectrophotometry <2.25>, and compare the spectrum with the Reference Spectrum: both spectra exhibit similar intensities of absorption at the same wave numbers.

(4) A solution of Clonidine Hydrochloride (1 in 50) responds to Qualitative Tests <1.09> for chloride.

pH <2.54> Dissolve 1.0 g of Clonidine Hydrochloride in 20 mL of water: the pH of this solution is between 4.0 and 5.5.

Purity (1) Clarity and color of solution—Dissolve 1.0 g of Clonidine Hydrochloride in 20 mL of water: the solution is clear and colorless.

(2) Heavy metals <1.07>—Proceed with 2.0 g of Clonidine Hydrochloride according to Method 1, and perform the test. Prepare the control solution with 2.0 mL of Standard Lead Solution (not more than 10 ppm).

(3) Arsenic <1.11>—Prepare the test solution with 0.5 g of Clonidine Hydrochloride according to Method 3, and perform the test (not more than 4 ppm).

(4) Related substances—Dissolve 0.20 g of Clonidine Hydrochloride in 2 mL of methanol, and use this solution as the sample solution. Pipet 1 mL of the sample solution, and add methanol to make exactly 100 mL. Pipet 1 mL and 2 mL of this solution, to each add methanol to make exactly 20 mL, and use these solutions as the standard solution (1) and the standard solution (2), respectively. Perform the test with these solutions as directed under Thin-layer Chromatography <2.03>. Spot 2 μ L each of the sample solution and standard solutions (1) and (2) on a plate of silica gel for thin-layer chromatography. Develop the plate with a mixture of toluene, 1,4-dioxane, ethanol (99.5) and ammonia solution (28) (10:8:2:1) to a distance of about 12 cm, air-dry the plate, and then dry at 100°C for 1 hour. Spray evenly sodium hypochlorite TS on the plate, air-dry the plate for 15 minutes, and then spray evenly potassium iodide starch TS on the plate: the spots other than the principal spot and the spot of the starting point obtained from the sample solution are not more intense than the spot from the standard solution (2), and the numbers of spots other than the principal spot and the spot of the starting point, which are more intense than the spot from the standard solution (1), are not more than 3.

Loss on drying <2.41> Not more than 0.5% (1 g, 105°C, 4 hours).

Residue on ignition <2.44> Not more than 0.1% (1 g).

Assay Weigh accurately about 0.4 g of Clonidine Hydrochloride, previously dried, and dissolve in 30 mL of acetic acid (100) by warming. After cooling, add 70 mL of acetic anhydride, and titrate <2.50> with 0.1 mol/L perchloric acid VS (potentiometric titration). Perform a blank determination in the same manner, and make any necessary correction.

Each mL of 0.1 mol/L perchloric acid VS
= 26.66 mg of $C_9H_9Cl_2N_3 \cdot HCl$

Containers and storage Containers—Tight containers.

Cloperastine Fendizoate

クロペラスチンフェンジゾ酸塩

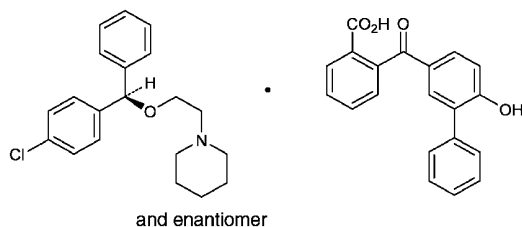

$C_{20}H_{24}ClNO \cdot C_{20}H_{14}O_4$: 648.19

1-[2-[(*R,S*)-(4-Chlorophenyl)(phenyl)methoxy]ethyl]piperidine mono[2-[(6-hydroxybiphenyl-3-yl)carbonyl]benzoate]
[85187-37-7]

Cloperastine Fendizoate, when dried, contains not less than 99.0% and not more than 101.0% of cloperastine fendizoate ($C_{20}H_{24}ClNO \cdot C_{20}H_{14}O_4$).

Description Cloperastine Fendizoate occurs as white, crystals or crystalline powder.

It is freely soluble in isopropylamine, slightly soluble in methanol, in ethanol (99.5) and in acetic acid (100), and practically insoluble in water.

A solution of Cloperastine Fendizoate in isopropylamine (1 in 20) shows no optical rotation.

Identification (1) Determine the absorption spectrum of a solution of Cloperastine Fendizoate in methanol (3 in 200,000) as directed under Ultraviolet-visible Spectrophotometry <2.24>, and compare the spectrum with the Reference Spectrum: both spectra exhibit similar intensities of absorption at the same wavelengths.

(2) Determine the infrared absorption spectrum of Cloperastine Fendizoate as directed in the potassium bromide disk method under Infrared Spectrophotometry <2.25>, and compare the spectrum with the Reference Spectrum: both spectra exhibit similar intensities of absorption at the same wave numbers.

Melting point <2.60> 186 – 190°C

Purity (1) Chloride <1.03>—To 2.0 g of Cloperastine Fendizoate add 50 mL of water, warm at 70°C for 5 minutes, cool, and filter. To 25 mL of the filtrate add 6 mL of dilute nitric acid and water to make 50 mL. Perform the test using this solution as the test solution. Prepare the control solution with 0.40 mL of 0.01 mol/L hydrochloric acid VS (not more than 0.014%).

(2) Heavy metals <1.07>—Proceed with 1.0 g of Cloperastine Fendizoate according to Method 2, and perform the test. Prepare the control solution with 2.0 mL of Standard Lead Solution (not more than 20 ppm).

(3) 4-Chlorobenzophenone—Dissolve exactly 25 mg of Cloperastine Fendizoate in the mobile phase A to make exactly 50 mL, and use this solution as the sample solution. Separately, dissolve exactly 25 mg of 4-chlorobenzophenone in the mobile phase A to make exactly 200 mL. Pipet 1 mL of this solution, add the mobile phase A to make exactly 100 mL, and use this solution as the standard solution. Perform the test with exactly 20 μ L each of the sample solution and

standard solution as directed under Liquid Chromatography <2.01> according to the following conditions, and determine the peak areas of 4-chlorobenzophenone by the automatic integration method: the peak area of 4-chlorobenzophenone obtained from the sample solution is not larger than that from the standard solution.

Operating conditions—

Detector: An ultraviolet absorption photometer (wavelength: 226 nm).

Column: A stainless steel column 4.6 mm in inside diameter and 15 cm in length, packed with octadecylsilanized silica gel for liquid chromatography (5 μ m in particle diameter).

Column temperature: A constant temperature of about 25°C.

Mobile phase A: A mixture of 0.1 mol/L potassium dihydrogen phosphate TS, acetonitrile for liquid chromatography and perchloric acid (400:320:1).

Mobile phase B: A mixture of acetonitrile for liquid chromatography, 0.1 mol/L potassium dihydrogen phosphate TS and perchloric acid (1050:450:1).

Flowing of mobile phase: Control the gradient by mixing the mobile phases A and B as directed in the following table.

Time after injection of sample (min)	Mobile phase A (vol%)	Mobile phase B (vol%)
0 – 12	100	0
12 – 22	100 → 0	0 → 100

Flow rate: 1.2 mL per minute.

System suitability—

Test for required detectability: Pipet 2 mL of the standard solution, and add the mobile phase A to make exactly 10 mL. Confirm that the peak area of 4-chlorobenzophenone obtained with 20 μ L of this solution is equivalent to 14 to 26% of that with 20 μ L of the standard solution.

System performance: When the procedure is run with 20 μ L of the standard solution under the above operating conditions, the number of theoretical plates and the symmetry factor of the peak of 4-chlorobenzophenone are not less than 10,000 and not more than 2.0, respectively.

System repeatability: When the test is repeated 6 times with 20 μ L of the standard solution under the above operating conditions, the relative standard deviation of the peak area of 4-chlorobenzophenone is not more than 2.0%.

Loss on drying <2.41> Not more than 0.5% (1 g, 105°C, 3 hours).

Residue on ignition <2.44> Not more than 0.1% (1 g).

Assay Weigh accurately about 1 g of dried Cloperastine Fendizoate, add 100 mL of acetic acid (100), warm to dissolve, cool, and titrate <2.50> with 0.1 mol/L perchloric acid VS (potentiometric titration). Perform a blank determination in the same manner, and make any necessary correction.

Each mL of 0.1 mol/L perchloric acid VS
= 64.82 mg of $C_{20}H_{24}ClNO \cdot C_{20}H_{14}O_4$

Containers and storage Containers—Well-closed containers.

Cloperastine Fendizoate Tablets

クロペラスチンフェンジゾ酸塩錠

Cloperastine Fendizoate Tablets contain not less than 95.0% and not more than 105.0% of the labeled amount of cloperastine fendizoate ($C_{20}H_{24}ClNO \cdot C_{20}H_{14}O_4$; 648.19).

Method of preparation Prepare as directed under Tablets, with Cloperastine Fendizoate.

Identification To a quantity of powdered Cloperastine Fendizoate Tablets, equivalent to 1.5 mg of Cloperastine Fendizoate, add methanol, shake thoroughly, add methanol to make 100 mL, and filter. Determine the absorption spectrum of the filtrate as directed under Ultraviolet-visible Spectrophotometry <2.24>: it exhibits maxima between 248 nm and 252 nm, and between 282 nm and 286 nm.

Uniformity of dosage units <6.02> Perform the test according to the following method: it meets the requirement of the Content uniformity test.

To 1 tablet of Cloperastine Fendizoate Tablets add exactly $V/10$ mL of the internal standard solution, add the mobile phase, shake vigorously until the tablet is disintegrated, add the mobile phase to make V mL so that each mL contains about 88 μ g of cloperastine fendizoate ($C_{20}H_{24}ClNO \cdot C_{20}H_{14}O_4$), and filter through a membrane filter with a pore size not exceeding 0.45 μ m. Discard the first 10 mL of the filtrate, and use the subsequent filtrate as the sample solution. Then, proceed as directed in the Assay.

$$\begin{aligned} & \text{Amount (mg) of cloperastine fendizoate} \\ & (C_{20}H_{24}ClNO \cdot C_{20}H_{14}O_4) \\ & = M_S \times Q_T/Q_S \times V/250 \end{aligned}$$

M_S : Amount (mg) of cloperastine fendizoate for assay taken

Internal standard solution—A solution of ethyl parahydroxybenzoate in the mobile phase (3 in 2000).

Dissolution <6.10> When the test is performed at 50 revolutions per minute according to the Paddle method, using 900 mL of 1st fluid for dissolution test as the dissolution medium, the dissolution rate in 90 minutes of Cloperastine Fendizoate Tablets is not less than 75%.

Start the test with 1 tablet of Cloperastine Fendizoate Tablets, withdraw not less than 20 mL of the medium at the specified minute after starting the test, and filter through a membrane filter with a pore size not exceeding 0.45 μ m. Discard not less than 10 mL of the first filtrate, pipet V mL of the subsequent filtrate, add the dissolution medium to make exactly V' mL so that each mL contains about 4.9 μ g of cloperastine fendizoate ($C_{20}H_{24}ClNO \cdot C_{20}H_{14}O_4$), and use this solution as the sample solution. Separately, weigh accurately about 25 mg of cloperastine fendizoate for assay, previously dried at 105°C for 3 hours, and dissolve in methanol to make exactly 200 mL. Pipet 4 mL of this solution, add the dissolution medium to make exactly 100 mL, and use this solution as the standard solution. Perform the test with exactly 10 μ L each of the sample solution and standard solution as directed under Liquid Chromatography <2.01> according to the following conditions, and determine the peak areas, A_T and A_S , of cloperastine in each solution.

Dissolution rate (%) with respect to the labeled amount of cloperastine fendizoate ($C_{20}H_{24}ClNO \cdot C_{20}H_{14}O_4$)

$$= M_S \times A_T/A_S \times V'/V \times 1/C \times 18$$

M_S : Amount (mg) of cloperastine fendizoate for assay taken

C : Labeled amount (mg) of cloperastine fendizoate ($C_{20}H_{24}ClNO \cdot C_{20}H_{14}O_4$) in 1 tablet

Operating conditions—

Proceed as directed in the operating conditions in the Assay.

System suitability—

System performance: When the procedure is run with 10 μ L of the standard solution under the above operating conditions, fendizoic acid and cloperastine are eluted in this order with the resolution between these peaks being not less than 6.

System repeatability: When the test is repeated 6 times with 10 μ L of the standard solution under the above operating conditions, the relative standard deviation of the peak area of cloperastine is not more than 2.0%.

Assay Weigh accurately the mass of not less than 20 tablets of Cloperastine Fendizoate Tablets, and powder. Weigh accurately a portion of the powder, equivalent to about 4.4 mg of cloperastine fendizoate ($C_{20}H_{24}ClNO \cdot C_{20}H_{14}O_4$), add exactly 5 mL of the internal standard solution, add 20 mL of the mobile phase, shake vigorously for 10 minutes, then add the mobile phase to make 50 mL, and filter through a membrane filter with a pore size not exceeding 0.45 μ m. Discard the first 10 mL of the filtrate and use the subsequent filtrate as the sample solution. Separately, weigh accurately about 22 mg of cloperastine fendizoate for assay, previously dried at 105°C for 3 hours, and dissolve in the mobile phase to make exactly 50 mL. Pipet 10 mL of this solution, add exactly 5 mL of the internal standard solution, add the mobile phase to make 50 mL, and use this solution as the standard solution. Perform the test with exactly 20 μ L each of the sample solution and standard solution as directed under Liquid Chromatography <2.01>, and calculate the ratios, Q_T and Q_S , of the peak area of cloperastine to that of the internal standard.

$$\begin{aligned} & \text{Amount (mg) of cloperastine fendizoate} \\ & (C_{20}H_{24}ClNO \cdot C_{20}H_{14}O_4) \\ & = M_S \times Q_T/Q_S \times 1/5 \end{aligned}$$

M_S : Amount (mg) of cloperastine fendizoate for assay taken

Internal standard solution—A solution of ethyl parahydroxybenzoate in the mobile phase (3 in 2000).

Operating conditions—

Detector: An ultraviolet absorption photometer (wavelength: 226 nm).

Column: A stainless steel column 4.6 mm in inside diameter and 15 cm in length, packed with octadecylsilanized silica gel for liquid chromatography (5 μ m in particle diameter).

Column temperature: A constant temperature of about 25°C.

Mobile phase: A mixture of 0.1 mol/L potassium dihydrogen phosphate TS, acetonitrile for liquid chromatography and perchloric acid (400:320:1).

Flow rate: Adjust so that the retention time of cloperastine is about 8 minutes.

System suitability—

System performance: When the procedure is run with 20 μ L of the standard solution under the above operating conditions, the internal standard, fendizoic acid and cloper-

astine are eluted in this order, and each resolution between these peaks is not less than 5, respectively.

System repeatability: When the test is repeated 6 times with 20 μL of the standard solution under the above operating conditions, the relative standard deviation of the ratio of the peak area of cloperastine to that of the internal standard is not more than 1.0%.

Containers and storage Containers—Tight containers.

Cloperastine Hydrochloride

クロペラスチン塩酸塩

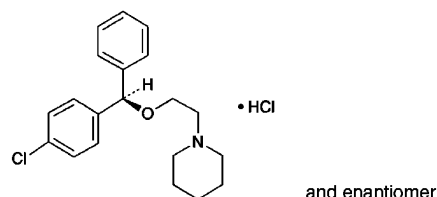

$\text{C}_{20}\text{H}_{24}\text{ClNO}\cdot\text{HCl}$: 366.32

1-{2-[(*RS*)-(4-Chlorophenyl)(phenyl)methoxy]ethyl}piperidine monohydrochloride

[14984-68-0]

Cloperastine Hydrochloride, when dried, contains not less than 98.5% of cloperastine hydrochloride ($\text{C}_{20}\text{H}_{24}\text{ClNO}\cdot\text{HCl}$).

Description Cloperastine Hydrochloride occurs as white, crystals or crystalline powder.

It is very soluble in water, in methanol, in ethanol (95) and in acetic acid (100), and soluble in acetic anhydride.

A solution of Cloperastine Hydrochloride (1 in 10) shows no optical rotation.

Identification (1) Determine the absorption spectrum of a solution of Cloperastine Hydrochloride in 0.1 mol/L hydrochloric acid TS (1 in 2500) as directed under Ultraviolet-visible Spectrophotometry <2.24>, and compare the spectrum with the Reference Spectrum 1: both spectra exhibit similar intensities of absorption at the same wavelengths. Separately, determine the absorption spectrum of a solution of Cloperastine Hydrochloride in 0.1 mol/L hydrochloric acid TS (1 in 62,500) as directed under Ultraviolet-visible Spectrophotometry <2.24>, and compare the spectrum with the Reference Spectrum 2: both spectra exhibit similar intensities of absorption at the same wavelengths.

(2) Determine the infrared absorption spectrum of Cloperastine Hydrochloride, previously dried, as directed in the potassium chloride disk method under Infrared Spectrophotometry <2.25>, and compare the spectrum with the Reference Spectrum: both spectra exhibit similar intensities of absorption at the same wave numbers.

(3) Shake 10 mL of a solution of Cloperastine Hydrochloride (1 in 100) with 2 mL of ammonia TS and 20 mL of diethyl ether, separate the water layer, wash the water layer with 20 mL of diethyl ether, and filter. Acidify the filtrate with dilute nitric acid: the solution responds to Qualitative Tests <1.09> for chloride.

Melting point <2.60> 149 – 153°C

Purity (1) Heavy metals <1.07>—Proceed with 1.0 g of Cloperastine Hydrochloride according to Method 2, and perform the test. Prepare the control solution with 2.0 mL of Standard Lead Solution (not more than 20 ppm).

(2) Related substances—Dissolve 40 mg of Cloperastine Hydrochloride in 50 mL of the mobile phase, and use this solution as the sample solution. Pipet 1 mL of the sample solution, add the mobile phase to make exactly 200 mL, and use this solution as the standard solution. Perform the test with exactly 20 μL each of the sample solution and standard solution as directed under Liquid Chromatography <2.01> according to the following conditions, and determine each peak area by the automatic integration method: the area of the peaks, having the relative retention times of about 0.8 and about 3.0 to cloperastine obtained from the sample solution are not larger than the peak area of cloperastine from the standard solution, and the area of the peak having the relative retention time about 2.0 from the sample solution is not larger than 5/3 times the peak area of cloperastine from the standard solution. The area of the peak other than cloperastine and the peaks mentioned above from the sample solution are not larger than 3/5 times the peak area of cloperastine from the standard solution, and the total area of these peaks is not larger than 2 times the peak area of cloperastine from the standard solution.

Operating conditions—

Detector: An ultraviolet absorption photometer (wavelength: 222 nm).

Column: A stainless steel column 4.6 mm in inside diameter and 15 cm in length, packed with octadecylsilanized silica gel for liquid chromatography (5 μm in particle diameter).

Column temperature: A constant temperature of about 25°C.

Mobile phase: A mixture of methanol, 0.1 mol/L potassium dihydrogen phosphate TS and perchloric acid (500:250:1).

Flow rate: Adjust so that the retention time of cloperastine is about 7 minutes.

Time span of measurement: About 4 times as long as the retention time of cloperastine, beginning after the solvent peak.

System suitability—

Test for required detectability: Pipet 2 mL of the standard solution, add the mobile phase to make exactly 20 mL. Confirm that the peak area of cloperastine obtained with 20 μL of this solution is equivalent to 7 to 13% of that with 20 μL of the standard solution.

System performance: Dissolve 30 mg of Cloperastine Hydrochloride and 40 mg of benzophenone in 100 mL of the mobile phase. To 2 mL of this solution add the mobile phase to make 50 mL. When the procedure is run with 20 μL of this solution under the above operating conditions, cloperastine and benzophenone are eluted in this order with the resolution between these peaks being not less than 6.

System repeatability: When the test is repeated 6 times with 20 μL of the standard solution under the above operating conditions, the relative standard deviation of the peak area of cloperastine is not more than 2.0%.

Loss on drying <2.41> Not more than 0.5% (1 g, 105°C, 3 hours).

Residue on ignition <2.44> Not more than 0.1% (1 g).

Assay Weigh accurately about 0.5 g of Cloperastine Hydrochloride, previously dried, dissolve in 70 mL of a mixture of acetic anhydride and acetic acid (100) (7:3), and titrate <2.50> with 0.1 mol/L perchloric acid VS (potentiometric titration). Perform a blank determination in the same manner, and make any necessary correction.

Each mL of 0.1 mol/L perchloric acid VS
= 36.63 mg of $\text{C}_{20}\text{H}_{24}\text{ClNO}\cdot\text{HCl}$

Containers and storage Containers—Tight containers.
Storage—Light-resistant.

Clopidogrel Sulfate

クロピドグレル硫酸塩

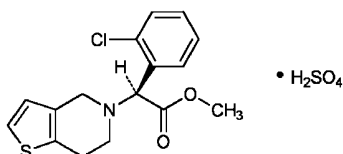

$C_{16}H_{16}ClNO_2S \cdot H_2SO_4$: 419.90

Methyl (2*S*)-2-(2-chlorophenyl)-2-[6,7-dihydrothieno[3,2-*c*]pyridin-5(4*H*)-yl]acetate monosulfate
[120202-66-6]

Clopidogrel Sulfate contains not less than 97.0% and not more than 101.5% of clopidogrel sulfate ($C_{16}H_{16}ClNO_2S \cdot H_2SO_4$), calculated on the anhydrous basis.

Description Clopidogrel Sulfate occurs as a white to pale yellow-white, crystalline powder or powder.

It is freely soluble in water and in methanol, and soluble in ethanol (99.5).

It gradually develops a brown color on exposure to light.

Melting point: about 177°C (with decomposition).

It shows crystal polymorphism.

Identification (1) Determine the absorption spectrum of a solution of Clopidogrel Sulfate in methanol (3 in 10,000) as directed under Ultraviolet-visible Spectrophotometry <2.24>, and compare the spectrum with the Reference Spectrum or the spectrum of a solution of Clopidogrel Sulfate RS prepared in the same manner as the sample solution: both spectra exhibit similar intensities of absorption at the same wavelengths.

(2) Determine the infrared absorption spectrum of Clopidogrel Sulfate as directed in the potassium bromide disk method under Infrared Spectrophotometry <2.25>, and compare the spectrum with the Reference Spectrum or the spectrum of Clopidogrel Sulfate RS: both spectra exhibit similar intensities of absorption at the same wave numbers. If any difference appears between the spectra, dissolve Clopidogrel Sulfate, or each of Clopidogrel Sulfate and Clopidogrel Sulfate RS in ethanol (99.5), respectively. Then evaporate the ethanol to dryness, and repeat the test on the residues dried in vacuum.

(3) Perform the test with Clopidogrel Sulfate as directed under Flame Coloration Test <1.04> (2): a green color appears.

(4) A solution of Clopidogrel Sulfate in a mixture of water and methanol (1:1) (1 in 100) responds to Qualitative Tests <1.09> (1) for sulfate.

Purity (1) Heavy metals <1.07>—Proceed with 1.0 g of Clopidogrel Sulfate according to Method 4, and perform the test. Prepare the control solution with 2.0 mL of Standard Lead Solution (not more than 20 ppm).

(2) Related substances—Dissolve 65 mg of Clopidogrel Sulfate in 10 mL of a mixture of acetonitrile for liquid chromatography and mobile phase A (3:2), and use this solution as the sample solution. Pipet 2 mL of the sample solution, and add a mixture of acetonitrile for liquid chromatography and the mobile phase A (3:2) to make exactly 100 mL. Pipet

2.5 mL of this solution, add a mixture of acetonitrile for liquid chromatography and the mobile phase A (3:2) to make exactly 50 mL, and use this solution as the standard solution. Perform the test with exactly 10 μ L each of the sample solution and standard solution as directed under Liquid Chromatography <2.01> according to the following conditions, and determine each peak area by the automatic integration method: the area of the peak, having the relative retention time of about 0.5 and about 1.1 to clopidogrel, obtained from the sample solution is not larger than 2 times the peak area of clopidogrel from the standard solution, the area of the peak other than clopidogrel and the peaks mentioned above from the sample solution is not larger than the peak area of clopidogrel from the standard solution, and the total area of the peaks other than clopidogrel from the sample solution is not larger than 5 times the peak area of clopidogrel from the standard solution.

Operating conditions—

Detector, column and column temperature: Proceed as directed in the operating conditions in the Assay.

Mobile phase A: Dissolve 0.87 g of sodium 1-pentanesulfonate in 1000 mL of water, and adjust to pH 2.5 with phosphoric acid. To 950 mL of this solution add 50 mL of methanol.

Mobile phase B: A mixture of acetonitrile for liquid chromatography and methanol (19:1).

Flowing of mobile phase: Control the gradient by mixing the mobile phases A and B as directed in the following table.

Time after injection of sample (min)	Mobile phase A (vol%)	Mobile phase B (vol%)
0 – 3	89.5	10.5
3 – 48	89.5 → 31.5	10.5 → 68.5
48 – 68	31.5	68.5

Flow rate: 1.0 mL per minute.

Time span of measurement: For 68 minutes after injection, beginning after the solvent peak.

System suitability—

Test for required detectability: To exactly 2 mL of the standard solution add a mixture of acetonitrile for liquid chromatography and the mobile phase A (3:2) to make exactly 20 mL. Confirm that the peak area of clopidogrel obtained with 10 μ L of this solution is equivalent to 7 to 13% of that with 10 μ L of the standard solution.

System performance: When the procedure is run with 10 μ L of the standard solution under the above operating conditions, the number of theoretical plates and the symmetry factor of the peak of clopidogrel are not less than 60,000 and not more than 2.0, respectively.

System repeatability: When the test is repeated 6 times with 10 μ L of the standard solution under the above operating conditions, the relative standard deviation of the peak area of clopidogrel is not more than 2.0%.

(3) Enantiomer—Dissolve 0.10 g of Clopidogrel Sulfate in 25 mL of ethanol (99.5) for liquid chromatography, add heptane for liquid chromatography to make 50 mL, and use this solution as the sample solution. Pipet 2.5 mL of the sample solution, and add a mixture of ethanol (99.5) for liquid chromatography and heptane for liquid chromatography (1:1) to make exactly 50 mL. Pipet 5 mL of this solution, add a mixture of ethanol (99.5) for liquid chromatography and heptane for liquid chromatography (1:1) to make exactly 50 mL, and use this solution as the standard solution. Perform the test with exactly 10 μ L each of the sample solution

and standard solution as directed under Liquid Chromatography <2.01> according to the following conditions, and determine each peak area by the automatic integration method: the peak area of the enantiomer, having the relative retention time of about 0.6 to clopidogrel, obtained from the sample solution is not larger than the peak area of clopidogrel from the standard solution.

Operating conditions—

Detector: An ultraviolet absorption photometer (wavelength: 220 nm).

Column: A stainless steel column 4.6 mm in inside diameter and 25 cm in length, packed with cellulose derivative-coated silica gel for liquid chromatography (10 μ m in particle diameter).

Column temperature: A constant temperature of about 25°C.

Mobile phase: A mixture of heptane for liquid chromatography and ethanol (99.5) for liquid chromatography (17:3).

Flow rate: Adjust so that the retention time of clopidogrel is about 18 minutes.

System suitability—

System performance: When the procedure is run with 10 μ L of the standard solution under the above operating conditions, the number of theoretical plates and the symmetry factor of the peak of clopidogrel are not less than 3500 and not more than 2.0, respectively.

System repeatability: When the test is repeated 6 times with 10 μ L of the standard solution under the above operating conditions, the relative standard deviation of the peak area of clopidogrel are not more than 2.0%.

Water <2.48> Not more than 0.5% (1 g, coulometric titration).

Residue on ignition <2.44> Not more than 0.1% (1 g).

Assay Weigh accurately about 45 mg each of Clopidogrel Sulfate and Clopidogrel Sulfate RS (separately, determine the water <2.48> in the same manner as Clopidogrel Sulfate), and dissolve them separately in the mobile phase to make exactly 50 mL. Take exactly 7 mL of each solution, add separately the mobile phase to make exactly 50 mL, and use these solutions as the sample solution and the standard solution, respectively. Perform the test with exactly 10 μ L each of the sample solution and standard solution as directed under Liquid Chromatography <2.01> according to the following conditions, and determine the peak areas, A_T and A_S , of clopidogrel in each solution.

Amount (mg) of clopidogrel sulfate ($C_{16}H_{16}ClNO_2S \cdot H_2SO_4$)
 $= M_S \times A_T / A_S$

M_S : Amount (mg) of Clopidogrel Sulfate RS taken, calculated on the anhydrous basis

Operating conditions—

Detector: An ultraviolet absorption photometer (wavelength: 220 nm).

Column: A stainless steel column 3.9 mm in inside diameter and 15 cm in length, packed with octadecylsilanized silica gel for liquid chromatography (5 μ m in particle diameter).

Column temperature: A constant temperature of about 30°C.

Mobile phase: Dissolve 0.87 g of sodium 1-pentanesulfonate in 1000 mL of water, and adjust to pH 2.5 with phosphoric acid. To 950 mL of this solution add 50 mL of methanol. To 600 mL of this solution, add 400 mL of a mixture of acetonitrile for liquid chromatography and methanol (19:1).

Flow rate: Adjust so that the retention time of clopidogrel

is about 8 minutes.

System suitability—

System performance: When the procedure is run with 10 μ L of the standard solution under the above operating conditions, the number of theoretical plates and the symmetry factor of the peak of clopidogrel are not less than 4500 and not more than 2.0, respectively.

System repeatability: When the test is repeated 6 times with 10 μ L of the standard solution under the above operating conditions, the relative standard deviation of the peak area of clopidogrel is not more than 1.0%.

Containers and storage Containers—Tight containers.

Storage—Light-resistant.

Clopidogrel Sulfate Tablets

クロピドゲレル硫酸塩錠

Clopidogrel Sulfate Tablets contain not less than 95.0% and not more than 105.0% of the labeled amount of clopidogrel ($C_{16}H_{16}ClNO_2S$; 321.82).

Method of preparation Prepare as directed under Tablets, with Clopidogrel Sulfate.

Identification To a quantity of powdered Clopidogrel Sulfate Tablets, equivalent to 75 mg of clopidogrel ($C_{16}H_{16}ClNO_2S$), add 50 mL of methanol, and after sonicating with ultrasonic waves with occasional shaking, add methanol to make 100 mL. To 10 mL of this solution add methanol to make 30 mL, and filter. Determine the absorption spectrum of the filtrate as directed under Ultraviolet-visible Spectrophotometry <2.24>: it exhibits maxima between 269 nm and 273 nm, and between 276 nm and 280 nm.

Purity Related substances—Keep the sample solution and the standard solution at 5°C or below and use within 24 hours. Take a quantity of Clopidogrel Sulfate Tablets equivalent to 0.15 g of clopidogrel ($C_{16}H_{16}ClNO_2S$), add 120 mL of the mobile phase, sonicate with occasional shaking until the tablets are disintegrated, and add the mobile phase to make 200 mL. Centrifuge this solution, to 10 mL of the supernatant liquid add the mobile phase to make 30 mL, and filter through a membrane filter with a pore size not exceeding 0.45 μ m. Discard the first 10 mL of the filtrate, and use the subsequent filtrate as the sample solution. Pipet 2 mL of the sample solution, add the mobile phase to make exactly 200 mL, and use this solution as the standard solution. Perform the test with exactly 10 μ L each of the sample solution and standard solution as directed under Liquid Chromatography <2.01> according to the following conditions, and determine each peak area by the automatic integration method: the area of the peaks, having the relative retention times of about 0.3, about 0.5 and about 0.9 to clopidogrel, obtained from the sample solution is not larger than 3/10 times the peak area of clopidogrel from the standard solution. The area of the peak having the relative retention time of about 2.0 from the sample solution is not larger than 1.2 times the peak area of clopidogrel from the standard solution. The area of the peak other than clopidogrel and the peaks mentioned above from the sample solution is not larger than 1/10 times the peak area of clopidogrel from the standard solution. The total area of the peaks other than clopidogrel from the sample solution is not larger than 1.7 times the peak area of clopidogrel from the standard solution.

Operating conditions—

Detector: An ultraviolet absorption photometer (wavelength: 220 nm).

Column: A stainless steel column of 4.6 mm in inside diameter and 15 cm in length, packed with ovomucoid-chemically bonded amino silica gel for liquid chromatography (5 μ m in particle diameter).

Column temperature: A constant temperature of about 25°C.

Mobile phase: Dissolve 1.36 g of potassium dihydrogen phosphate in 1000 mL of water, and to 750 mL of this solution add 250 mL of acetonitrile for liquid chromatography.

Flow rate: Adjust so that the retention time of clopidogrel is about 6 minutes.

Time span of measurement: About 2.5 times as long as the retention time of clopidogrel, beginning after the solvent peak.

System suitability—

Test for required detectability: To exactly 5 mL of the standard solution add the mobile phase to make exactly 100 mL. Confirm that the peak area of clopidogrel obtained with 10 μ L of this solution is equivalent to 3.5 to 6.5% of that with 10 μ L of the standard solution.

System performance: When the procedure is run with 10 μ L of the standard solution under the above operating conditions, the number of theoretical plates and the symmetry factor of the peak of clopidogrel are not less than 2500 and not more than 2.0, respectively.

System repeatability: When the test is repeated 6 times with 10 μ L of the standard solution under the above operating conditions, the relative standard deviation of the peak area of clopidogrel is not more than 2.0%.

Uniformity of dosage units <6.02> Perform the Mass variation test, or the Content uniformity test according to the following method: it meets the requirement.

To 1 tablet of Clopidogrel Sulfate Tablets add a suitable amount of the mobile phase, sonicate with occasional shaking until the tablet is disintegrated, and add the mobile phase to make exactly 50 mL. Filter the solution through a membrane filter with a pore size not exceeding 0.45 μ m. Discard the first 10 mL of the filtrate, pipet 2 mL of the subsequent filtrate, add exactly $V/5$ mL of the internal standard solution, and add the mobile phase to make V mL so that each mL contains about 0.1 mg of clopidogrel ($C_{16}H_{16}ClNO_2S$). Use this solution as the sample solution. Then, proceed as directed in the Assay.

$$\begin{aligned} &\text{Amount (mg) of clopidogrel (C}_{16}\text{H}_{16}\text{ClNO}_2\text{S)} \\ &= M_S \times Q_T/Q_S \times V/10 \times 0.766 \end{aligned}$$

M_S : Amount (mg) of Clopidogrel Sulfate RS taken, calculated on the anhydrous basis

Internal standard solution—A solution of isopropyl parahydroxybenzoate in the mobile phase (1 in 1500).

Dissolution <6.10> When the test is performed at 50 revolutions per minute according to the Paddle method, using 900 mL of water as the dissolution medium, the dissolution rate of 25-mg tablet in 30 minutes is not less than 70%, and that of 75-mg tablet in 45 minutes is not less than 80%.

Start the test with 1 tablet of Clopidogrel Sulfate Tablets, withdraw not less than 20 mL of the medium at the specified minute after starting the test, and filter through a membrane filter with a pore size not exceeding 0.45 μ m. Discard not less than 10 mL of the first filtrate, pipet V mL of the subsequent filtrate, add water to make exactly V' mL so that each mL contains about 28 μ g of clopidogrel ($C_{16}H_{16}ClNO_2S$), and

use this solution as the sample solution. Separately, weigh accurately about 30 mg of Clopidogrel Sulfate RS (separately determine the water <2.48> in the same manner as Clopidogrel Sulfate), dissolve in 5 mL of methanol, and add water to make exactly 100 mL. Pipet 6 mL of this solution, add water to make exactly 50 mL, and use this solution as the standard solution. Determine the absorbances, A_T and A_S , at 240 nm of the sample solution and standard solution as directed under Ultraviolet-visible Spectrophotometry <2.24>, using water as a blank.

Dissolution rate (%) with respect to the labeled amount of clopidogrel ($C_{16}H_{16}ClNO_2S$)

$$= M_S \times A_T/A_S \times V'/V \times 1/C \times 108 \times 0.766$$

M_S : Amount (mg) of Clopidogrel Sulfate RS taken, calculated on the anhydrous basis

C : Labeled amount (mg) of clopidogrel ($C_{16}H_{16}ClNO_2S$) in 1 tablet

Assay To 20 tablets of Clopidogrel Sulfate Tablets add 400 mL of the mobile phase, sonicate with occasional shaking until the tablets are disintegrated, add the mobile phase to make exactly 500 mL, and filter through a membrane filter with a pore size not exceeding 0.45 μ m. Discard the first 10 mL of the filtrate, pipet 5 mL of the subsequent filtrate, add the mobile phase to make exactly V mL so that each mL contains about 0.5 mg of clopidogrel ($C_{16}H_{16}ClNO_2S$). Pipet 4 mL of this solution, add exactly 4 mL of the internal standard solution and the mobile phase to make 20 mL, and use this solution as the sample solution. Separately, weigh accurately about 33 mg of Clopidogrel Sulfate RS (separately determine the water <2.48> in the same manner as Clopidogrel Sulfate), and dissolve in the mobile phase to make exactly 50 mL. Pipet 4 mL of this solution, add exactly 4 mL of the internal standard solution and the mobile phase to make 20 mL, and use this solution as the standard solution. Perform the test with 10 μ L each of the sample solution and standard solution as directed under Liquid Chromatography <2.01> according to the following conditions, and calculate the ratios, Q_T and Q_S , of the peak area of clopidogrel to that of the internal standard.

$$\begin{aligned} &\text{Amount (mg) of clopidogrel (C}_{16}\text{H}_{16}\text{ClNO}_2\text{S) in 1 tablet} \\ &\text{of Clopidogrel Sulfate Tablets} \\ &= M_S \times Q_T/Q_S \times V/10 \times 0.766 \end{aligned}$$

M_S : Amount (mg) of Clopidogrel Sulfate RS taken, calculated on the anhydrous basis

Internal standard solution—A solution of isopropyl parahydroxybenzoate in the mobile phase (1 in 1500).

Operating conditions—

Detector: An ultraviolet absorption photometer (wavelength: 220 nm).

Column: A stainless steel column of 3.9 mm in inside diameter and 15 cm in length, packed with octadecylsilanized silica gel for liquid chromatography (5 μ m in particle diameter).

Column temperature: A constant temperature of about 30°C.

Mobile phase: Dissolve 0.87 g of sodium 1-pentanesulfonate in 1000 mL of water, and adjust to pH 2.5 with phosphoric acid. To 950 mL of this solution add 50 mL of methanol. To 600 mL of this solution add 400 mL of a mixture of acetonitrile for liquid chromatography and methanol (19:1).

Flow rate: Adjust so that the retention time of clopidogrel is about 8 minutes.

System suitability—

System performance: When the procedure is run with 10

μL of the standard solution under the above operating conditions, the internal standard and clonidogrel are eluted in this order with the resolution between these peaks being not less than 4.

System repeatability: When the test is repeated 6 times with 10 μL of the standard solution under the above operating conditions, the relative standard deviation of the ratio of the peak area of clonidogrel to that of the internal standard is not more than 1.0%.

Containers and storage Containers—Tight containers.

Clorazepate Dipotassium

クロラゼパ酸二カリウム

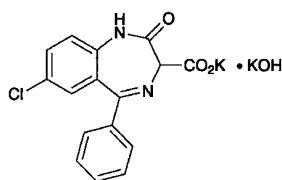

$\text{C}_{16}\text{H}_{10}\text{ClKN}_2\text{O}_3 \cdot \text{KOH}$: 408.92

Monopotassium 7-chloro-2-oxo-5-phenyl-2,3-dihydro-1*H*-1,4-benzodiazepine-3-carboxylate mono (potassium hydroxide)
[57109-90-7]

Clorazepate Dipotassium, when dried, contains not less than 98.5% and not more than 101.0% of clorazepate dipotassium ($\text{C}_{16}\text{H}_{10}\text{ClKN}_2\text{O}_3 \cdot \text{KOH}$).

Description Clorazepate Dipotassium occurs as white to light yellow, crystals or crystalline powder.

It is freely soluble in water, and very slightly soluble in ethanol (99.5).

It dissolves in acetic acid (100).

The pH of a solution obtained by dissolving 1 g of Clorazepate Dipotassium in 100 mL of water is between 11.5 and 12.5.

It gradually turns yellow on exposure to light.

Identification (1) Carefully and gradually ignite to redness 30 mg of Clorazepate Dipotassium with 50 mg of sodium. After cooling, add 3 drops of ethanol (99.5) and 5 mL of water, mix well, and filter: the filtrate responds to Qualitative Tests <1.09> for chloride.

(2) Determine the absorption spectrum of a solution of Clorazepate Dipotassium (1 in 200,000) as directed under Ultraviolet-visible Spectrophotometry <2.24>, and compare the spectrum with the Reference Spectrum: both spectra exhibit similar intensities of absorption at the same wavelengths.

(3) Determine the infrared absorption spectrum of Clorazepate Dipotassium as directed in the potassium bromide disk method under Infrared Spectrophotometry <2.25>, and compare the spectrum with the Reference Spectrum: both spectra exhibit similar intensities of absorption at the same wave numbers.

(4) Clorazepate Dipotassium responds to Qualitative Tests <1.09> (1) for potassium salt.

Purity (1) Chloride <1.03>—Dissolve 1.0 g of Clorazepate Dipotassium in 20 mL of water, add 20 mL of acetone, 6 mL of dilute nitric acid and water to make 50 mL. Perform the test with this solution as the test solution. Prepare the control solution as follows: To 0.40 mL of 0.01 mol/L hydrochloric acid VS add 20 mL of acetone, 6 mL of dilute nitric

acid and water to make 50 mL (not more than 0.014%).

(2) Heavy metals <1.07>—Proceed with 1.0 g of Clorazepate Dipotassium according to Method 2, and perform the test. Prepare the control solution with 2.0 mL of Standard Lead Solution (not more than 20 ppm).

(3) Arsenic <1.11>—Prepare the test solution with 1.0 g of Clorazepate Dipotassium according to Method 3, and perform the test (not more than 2 ppm).

(4) Related substances—Dissolve 15 mg of Clorazepate Dipotassium in 25 mL of a mixture of water, potassium carbonate solution (97 in 1000) and acetonitrile (3:1:1), and use this solution as the sample solution. Pipet 1 mL of the sample solution, add the mixture of water, potassium carbonate solution (97 in 1000) and acetonitrile (3:1:1) to make exactly 200 mL, and use this solution as the standard solution. Prepare these solutions quickly and perform the test within 3 minutes. Perform the test with exactly 5 μL each of the sample solution and standard solution as directed under Liquid Chromatography <2.01> according to the following conditions, and determine each peak area by the automatic integration method: the peak area of nordiazepam, having the relative retention time of about 3.0 to clorazepic acid, obtained from the sample solution is not larger than the peak area of clorazepic acid from the standard solution, the area of the peak other than clorazepic acid and nordiazepam is not larger than 1/5 times the peak area of clorazepic acid from the standard solution, and the total area of the peaks other than clorazepic acid is not larger than 2 times the peak area of clorazepic acid from the standard solution. For the area of the peak of nordiazepam, multiply the correction factor, 0.64.

Operating conditions—

Detector: An ultraviolet absorption photometer (wavelength: 232 nm).

Column: A stainless steel column 4.6 mm in inside diameter and 15 cm in length, packed with octadecylsilanized silica gel for liquid chromatography (5 μm in particle diameter).

Column temperature: A constant temperature of about 25°C.

Mobile phase: Dissolve 13.8 g of sodium dihydrogen phosphate dihydrate in 500 mL of water, and adjust to pH 8.0 with sodium hydroxide TS. To 100 mL of this solution add 400 mL of acetonitrile and 300 mL of water.

Flow rate: Adjust so that the retention time of clorazepic acid is about 1.3 minutes.

Time span of measurement: About 10 times as long as the retention time of clorazepic acid, beginning after the solvent peak.

System suitability—

Test for required detectability: To exactly 5 mL of the standard solution add the mixture of water, potassium carbonate solution (97 in 1000) and acetonitrile (3:1:1) to make exactly 25 mL. Confirm that the peak area of clorazepic acid obtained with 5 μL of this solution is equivalent to 15 to 25% of that with 5 μL of the standard solution.

System performance: When the procedure is run with 5 μL of the standard solution under the above operating conditions, the number of theoretical plates and the symmetry factor of the peak of clorazepic acid are not less than 3000 and not more than 1.5, respectively.

System repeatability: When the test is repeated 6 times with 5 μL of the standard solution under the above operating conditions, the relative standard deviation of the peak area of clorazepic acid is not more than 1.5%.

Loss on drying <2.41> Not more than 0.5% (1 g, in vacuum, phosphorus (V) oxide, 60°C, 5 hours).

Assay Weigh accurately about 0.15 g of Clorazepate Dipotassium, previously dried, dissolve in 100 mL of acetic acid (100), and titrate <2.50> with 0.1 mol/L perchloric acid VS until the color of solution changes from violet to blue-green through blue (indicator: 3 drops of crystal violet TS). Perform a blank determination in the same manner, and make any necessary correction.

Each mL of 0.1 mol/L perchloric acid VS
= 13.63 mg of $C_{16}H_{10}ClKN_2O_3 \cdot KOH$

Containers and storage Containers—Tight containers.
Storage—Light-resistant.

Clorazepate Dipotassium Capsules

クロラゼパ酸ニカリウムカプセル

Clorazepate Dipotassium Capsules contain not less than 93.0% and not more than 107.0% of the labeled amount of clorazepate dipotassium ($C_{16}H_{10}ClKN_2O_3 \cdot KOH$: 408.92).

Method of preparation Prepare as directed under Capsules, with Clorazepate Dipotassium.

Identification To 10 mL of the sample solution obtained in the Assay add water to make 20 mL. Determine the absorption spectrum of this solution as directed under Ultraviolet-visible Spectrophotometry <2.24>: it exhibits a maximum between 228 nm and 232 nm.

Purity Related substances—Take out the contents of Clorazepate Dipotassium Capsules, and powder. To a portion of the powder, equivalent to 15 mg of Clorazepate Dipotassium, add a mixture of water, potassium carbonate solution (97 in 1000) and acetonitrile (3:1:1) to make 25 mL, and shake for 10 minutes. Filter the solution through a membrane filter with a pore size not exceeding 0.45 μm , discard the first 5 mL of the filtrate, and use the subsequent filtrate as the sample solution. Pipet 1 mL of the sample solution, add a mixture of water, potassium carbonate solution (97 in 1000) and acetonitrile (3:1:1) to make exactly 200 mL, and use this solution as the standard solution. Then, proceed as directed in the Purity (4) under Clorazepate Dipotassium: the peak area of nordiazepam, having the relative retention time of about 3.0 to clorazepic acid, obtained from the sample solution is not larger than 3 times the peak area of clorazepic acid from the standard solution, and the total area of the peaks other than clorazepic acid and nordiazepam is not larger than the peak area of clorazepic acid from the standard solution. For the peak area of nordiazepam, multiply the correction factor, 0.64.

Uniformity of dosage units <6.02> Perform the test according to the following method: it meets the requirement of the Content uniformity test.

To 1 capsule of Clorazepate Dipotassium Capsules add 70 mL of water, shake for 15 minutes, and add water to make exactly 100 mL. Centrifuge the solution, pipet V mL of the supernatant liquid, add water to make exactly V' mL so that each mL contains about 12 μg of clorazepate dipotassium ($C_{16}H_{10}ClKN_2O_3 \cdot KOH$), and use this solution as the sample solution. Then, proceed as directed in the Assay.

Amount (mg) of clorazepate dipotassium
($C_{16}H_{10}ClKN_2O_3 \cdot KOH$)
= $M_S \times A_T/A_S \times V'/V \times 2/25$

M_S : Amount (mg) of clorazepate dipotassium for assay taken

Dissolution <6.10> When the test is performed at 50 revolutions per minute according to the Paddle method using the sinker, using 900 mL of water as the dissolution medium, the dissolution rate in 30 minutes of Clorazepate Dipotassium Capsules is not less than 80%.

Start the test with 1 capsule of Clorazepate Dipotassium Capsules, withdraw not less than 20 mL of the medium at the specified minute after starting the test, and filter through a membrane filter with a pore size not exceeding 0.45 μm . Discard not less than 10 mL of the first filtrate, pipet V mL of the subsequent filtrate, add water to make exactly V' mL so that each mL contains about 8.3 μg of clorazepate dipotassium ($C_{16}H_{10}ClKN_2O_3 \cdot KOH$), and use this solution as the sample solution. Separately, weigh accurately about 21 mg of clorazepate dipotassium for assay, previously dried in vacuum over phosphorus (V) oxide at 60°C for 5 hours, and dissolve in water to make exactly 100 mL. Pipet 4 mL of this solution, add water to make exactly 100 mL, and use this solution as the standard solution. Determine the absorbances, A_T and A_S , at 252 nm of the sample solution and standard solution as directed under Ultraviolet-visible Spectrophotometry <2.24>.

Dissolution rate (%) with respect to the labeled amount of clorazepate dipotassium ($C_{16}H_{10}ClKN_2O_3 \cdot KOH$)
= $M_S \times A_T/A_S \times V'/V \times 1/C \times 36$

M_S : Amount (mg) of clorazepate dipotassium for assay taken

C : Labeled amount (mg) of clorazepate dipotassium ($C_{16}H_{10}ClKN_2O_3 \cdot KOH$) in 1 capsule

Assay Carefully take out the contents of not less than 20 Clorazepate Dipotassium Capsules, weigh accurately the mass of the contents, and powder. Weigh accurately a portion of the powder, equivalent to about 15 mg of clorazepate dipotassium ($C_{16}H_{10}ClKN_2O_3 \cdot KOH$), add 70 mL of water, shake for 15 minutes, and add water to make exactly 100 mL. Centrifuge the solution, pipet 4 mL of the supernatant liquid, add water to make exactly 50 mL, and use this solution as the sample solution. Separately, weigh accurately about 15 mg of clorazepate dipotassium for assay, previously dried in vacuum over phosphorus (V) oxide at 60°C for 5 hours, and dissolve in water to make exactly 100 mL. Pipet 4 mL of this solution, add water to make exactly 50 mL, and use this solution as the standard solution. Perform the test with the sample solution and standard solution as directed under Ultraviolet-visible Spectrophotometry <2.24>, and determine the absorbances, A_T and A_S , at 252 nm.

Amount (mg) of clorazepate dipotassium
($C_{16}H_{10}ClKN_2O_3 \cdot KOH$)
= $M_S \times A_T/A_S$

M_S : Amount (mg) of clorazepate dipotassium for assay taken

Containers and storage Containers—Tight containers.

Clotiazepam

クロチアゼパム

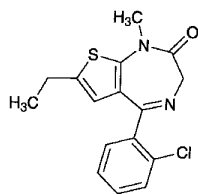

$C_{16}H_{15}ClN_2OS$: 318.82

5-(2-Chlorophenyl)-7-ethyl-1-methyl-1,3-dihydro-2H-thieno[2,3-e][1,4]diazepin-2-one
[33671-46-4]

Clotiazepam, when dried, contains not less than 98.5% of clotiazepam ($C_{16}H_{15}ClN_2OS$).

Description Clotiazepam occurs as white to light yellow-white, crystals or crystalline powder. It is odorless, and has a slightly bitter taste.

It is very soluble in chloroform, freely soluble in methanol, in ethanol (95), in acetone, in acetic acid (100) and in ethyl acetate, soluble in diethyl ether, and practically insoluble in water.

It dissolves in 0.1 mol/L hydrochloric acid TS.

It is gradually colored by light.

Identification (1) Dissolve 0.01 g of Clotiazepam in 3 mL of sulfuric acid: the solution shows a light yellow fluorescence under ultraviolet light (main wavelength: 365 nm).

(2) Determine the absorption spectrum of a solution of Clotiazepam in 0.1 mol/L hydrochloric acid TS (1 in 100,000) as directed under Ultraviolet-visible Spectrophotometry <2.24>, and compare the spectrum with the Reference Spectrum: both spectra exhibit similar intensities of absorption at the same wavelengths.

(3) Prepare the test solution with 0.01 g of Clotiazepam as directed under Oxygen Flask Combustion Method <1.06>, using 10 mL of diluted hydrogen peroxide (30) (1 in 5) as the absorbing liquid. Apply a small amount of water to the upper part of the Apparatus A, pull out C carefully, wash C, B and the inner side of A with 15 mL of methanol, and use the obtained solution as the test solution. Add 0.5 mL of dilute nitric acid to 15 mL of the test solution: this solution responds to Qualitative Tests <1.09> (2) for chloride. The remaining test solution responds to Qualitative Tests <1.09> (1) for sulfate.

Melting point <2.60> 106 – 109°C

Purity (1) Clarity and color of solution—Dissolve 1.0 g of Clotiazepam in 10 mL of ethanol (95): the solution is clear and is not more colored than the following control solution.

Control solution: To 5 mL of Matching Fluid C add 0.01 mol/L hydrochloric acid TS to make 10 mL.

(2) Chloride <1.03>—To 1.0 g of Clotiazepam add 50 mL of water, shake for 30 minutes, and filter. To 30 mL of the filtrate add 6 mL of dilute nitric acid and water to make 50 mL. Perform the test using this solution as the test solution. Prepare the control solution with 0.25 mL of 0.01 mol/L hydrochloric acid VS (not more than 0.015%).

(3) Heavy metals <1.07>—Proceed with 2.0 g of Clotiazepam according to Method 4, and perform the test. Prepare the control solution with 2.0 mL of Standard Lead Solution (not more than 10 ppm).

(4) Arsenic <1.11>—Prepare the test solution with 1.0 g

of Clotiazepam, according to Method 3, and perform the test (not more than 2 ppm).

(5) Related substances—Dissolve 0.25 g of Clotiazepam in 10 mL of acetone, and use this solution as the sample solution. Pipet 1 mL of the sample solution, add acetone to make exactly 20 mL, pipet 2 mL of this solution, add acetone to make exactly 50 mL, and use this solution as the standard solution. Perform the test with these solutions as directed under Thin-layer Chromatography <2.03>. Spot 10 μ L each of the sample solution and standard solution on a plate of silica gel with fluorescent indicator for thin-layer chromatography. Develop the plate with a mixture of chloroform and acetone (5:1) to a distance of about 10 cm, and air-dry the plate. Examine under ultraviolet light (main wavelength: 254 nm): the spots other than the principal spot obtained from the sample solution are not more intense than the spot from the standard solution.

Loss on drying <2.41> Not more than 0.5% (1 g, 80°C, 3 hours).

Residue on ignition <2.44> not more than 0.1% (1 g).

Assay Weigh accurately about 0.5 g of Clotiazepam, previously dried, dissolve in 80 mL of acetic acid (100), and titrate <2.50> with 0.1 mol/L perchloric acid (potentiometric titration). Perform a blank determination in the same manner, and make any necessary correction.

Each mL of 0.1 mol/L perchloric acid VS
= 31.88 mg of $C_{16}H_{15}ClN_2OS$

Containers and storage Containers—Tight containers.
Storage—Light-resistant.

Clotiazepam Tablets

クロチアゼパム錠

Clotiazepam Tablets contain not less than 95.0% and not more than 105.0% of the labeled amount of clotiazepam ($C_{16}H_{15}ClN_2OS$: 318.82).

Method of preparation Prepare as directed under Tablets, with Clotiazepam.

Identification Determine the absorption spectrum of the sample solution obtained in the Assay as directed under Ultraviolet-visible Spectrophotometry <2.24>: it exhibits a maximum between 260 nm and 264 nm.

Uniformity of dosage unit <6.02> Perform the test according to the following method: it meets the requirement of the Content uniformity test.

To 1 tablet of Clotiazepam Tablets add 35 mL of 0.1 mol/L hydrochloric acid TS, stir until the tablet is completely disintegrated, stir for a further 10 minutes, and add 0.1 mol/L hydrochloric acid TS to make exactly 50 mL. Centrifuge this solution, pipet V mL of the supernatant liquid, add 0.1 mol/L hydrochloric acid TS to make exactly V' mL so that each mL contains about 10 μ g of clotiazepam ($C_{16}H_{15}ClN_2OS$), and use this solution as the sample solution. Then, proceed as directed in the Assay.

Amount (mg) of clotiazepam ($C_{16}H_{15}ClN_2OS$)
= $M_S \times A_T/A_S \times V'/V \times 1/50$

M_S : Amount (mg) of clotiazepam for assay taken

Dissolution <6.10> When the test is performed at 50 revolutions per minute according to the Paddle method, using 900

mL of 1st fluid for dissolution test as the dissolution medium, the dissolution rate in 45 minutes of Clotiazepam Tablets is not less than 80%.

Start the test with 1 tablet of Clotiazepam Tablets, withdraw not less than 20 mL of the medium at the specified minute after starting the test, and filter through a membrane filter with a pore size not exceeding 0.45 μm . Discard not less than 10 mL of the first filtrate, pipet V mL of the subsequent filtrate, add the dissolution medium to make exactly V' mL so that each mL contains about 5.6 μg of clotiazepam ($\text{C}_{16}\text{H}_{15}\text{ClN}_2\text{OS}$), and use this solution as the sample solution. Separately, weigh accurately about 28 mg of clotiazepam for assay, previously dried at 80°C for 3 hours, and dissolve in ethanol (95) to make exactly 25 mL. Pipet 5 mL of this solution, and add the dissolution medium to make exactly 100 mL. Pipet 5 mL of this solution, add the dissolution medium to make exactly 50 mL, and use this solution as the standard solution. Determine the absorbances, A_T and A_S , of the sample solution and standard solution at 262 nm as directed under Ultraviolet-visible Spectrophotometry <2.24>, using the dissolution medium as the blank.

Dissolution rate (%) with respect to the labeled amount of clotiazepam ($\text{C}_{16}\text{H}_{15}\text{ClN}_2\text{OS}$)

$$= M_S \times A_T / A_S \times V' / V \times 1 / C \times 18$$

M_S : Amount (mg) of clotiazepam for assay taken

C : Labeled amount (mg) of clotiazepam ($\text{C}_{16}\text{H}_{15}\text{ClN}_2\text{OS}$) in 1 tablet

Assay To 20 Clotiazepam Tablets add 350 mL of 0.1 mol/L hydrochloric acid TS, stir until the tablets are completely disintegrated, stir for a further 10 minutes, and add 0.1 mol/L hydrochloric acid TS to make exactly 500 mL. Centrifuge this solution, pipet V mL of the supernatant liquid, add 0.1 mol/L hydrochloric acid TS to make exactly V' mL so that each mL contains about 10 μg of clotiazepam ($\text{C}_{16}\text{H}_{15}\text{ClN}_2\text{OS}$), and use this solution as the sample solution. Separately, weigh accurately about 25 mg of clotiazepam for assay, previously dried at 80°C for 3 hours, and dissolve in 0.1 mol/L hydrochloric acid TS to make exactly 50 mL. Pipet 2 mL of this solution, add 0.1 mol/L hydrochloric acid TS to make exactly 100 mL, and use this solution as the standard solution. Determine the absorbances, A_T and A_S , of the sample solution and standard solution at 261 nm as directed under Ultraviolet-visible Spectrophotometry <2.24>.

Amount (mg) of clotiazepam ($\text{C}_{16}\text{H}_{15}\text{ClN}_2\text{OS}$) in 1 tablet

$$= M_S \times A_T / A_S \times V' / V \times 1 / 100$$

M_S : Amount (mg) of clotiazepam for assay taken

Containers and storage Containers—Tight containers. Storage—Light-resistant.

Clotrimazole

クロトリマゾール

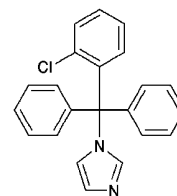

$\text{C}_{22}\text{H}_{17}\text{ClN}_2$: 344.84

1-[(2-Chlorophenyl)(diphenyl)methyl]-1H-imidazole
[23593-75-1]

Clotrimazole, when dried, contains not less than 98.0% of clotrimazole ($\text{C}_{22}\text{H}_{17}\text{ClN}_2$).

Description Clotrimazole occurs as a white, crystalline powder. It is odorless and tasteless.

It is freely soluble in dichloromethane and in acetic acid (100), soluble in *N,N*-dimethylformamide, in methanol and in ethanol (95), slightly soluble in diethyl ether, and practically insoluble in water.

Identification (1) To 0.1 g of Clotrimazole add 10 mL of 5 mol/L hydrochloric acid TS, dissolve by heating, and cool. To this solution add 3 drops of Reinecke salt TS: a light red precipitate is produced.

(2) Determine the absorption spectrum of a solution of Clotrimazole in methanol (1 in 5000) as directed under Ultraviolet-visible Spectrophotometry <2.24>, and compare the spectrum with the Reference Spectrum: both spectra exhibit similar intensities of absorption at the same wavelengths.

(3) Determine the infrared absorption spectrum of Clotrimazole, previously dried, as directed in the potassium bromide disk method under Infrared Spectrophotometry <2.25>, and compare the spectrum with the Reference Spectrum: both spectra exhibit similar intensities of absorption at the same wave numbers.

(4) Perform the test with Clotrimazole as directed under Flame Coloration Test <1.04> (2): a green color appears.

Melting point <2.60> 142 – 145°C

Purity (1) Clarity and color of solution—Dissolve 0.5 g of Clotrimazole in 10 mL of dichloromethane: the solution is clear and colorless.

(2) Chloride <1.03>—Dissolve 1.0 g of Clotrimazole in 40 mL of *N,N*-dimethylformamide, add 6 mL of dilute nitric acid and water to make 50 mL. Perform the test using this solution as the test solution. Prepare the control solution with 0.60 mL of 0.01 mol/L hydrochloric acid VS, 40 mL of *N,N*-dimethylformamide, 6 mL of dilute nitric acid and water to make 50 mL (not more than 0.021%).

(3) Sulfate <1.14>—Dissolve 0.5 g of Clotrimazole in 10 mL of methanol, and add 1 mL of dilute hydrochloric acid and water to make 50 mL. Perform the test using this solution as the test solution. Prepare the control solution with 0.05 mL of 0.005 mol/L sulfuric acid VS, 10 mL of methanol, 1 mL of dilute hydrochloric acid and water to make 50 mL (not more than 0.048%).

(4) Heavy metals <1.07>—Proceed with 2.0 g of Clotrimazole according to Method 2, and perform the test. Prepare the control solution with 2.0 mL of Standard Lead Solution (not more than 10 ppm).

(5) Arsenic <1.11>—Prepare the test solution with 1.0 g of Clotrimazole according to Method 3, and perform the test

(not more than 2 ppm).

(6) Imidazole—Dissolve 0.10 g of Clotrimazole in exactly 10 mL of dichloromethane, and use this solution as the sample solution. Separately, dissolve 25 mg of imidazole for thin-layer chromatography in dichloromethane to make exactly 50 mL. Pipet 5 mL of this solution, add dichloromethane to make exactly 50 mL, and use this solution as the standard solution. Perform the test with these solutions as directed under Thin-layer Chromatography <2.03>. Spot 10 μ L each of the sample solution and standard solution on a plate of silica gel for thin-layer chromatography. Develop the plate with a mixture of methanol and chloroform (3:2) to a distance of about 10 cm, and air-dry the plate. Spray evenly sodium hypochlorite TS on the plate, and air-dry the plate for 15 minutes, then spray evenly potassium iodide-starch TS on the plate: the spot obtained from the sample solution, corresponding to that from the standard solution, is not more intense than that from the standard solution.

(7) (2-Chlorophenyl)-diphenylmethanol—Dissolve 0.20 g of Clotrimazole in exactly 10 mL of dichloromethane, and use this solution as the sample solution. Separately, dissolve 10 mg of (2-chlorophenyl)-diphenylmethanol for thin-layer chromatography in dichloromethane to make exactly 100 mL, and use this solution as the standard solution. Perform the test with these solutions as directed under Thin-layer Chromatography <2.03>. Spot 10 μ L each of the sample solution and standard solution on a plate of silica gel with fluorescent indicator for thin-layer chromatography. Develop the plate with a mixture of ethyl acetate and ammonia solution (28) (50:1) to a distance of about 10 cm, and air-dry the plate. Examine under ultraviolet light (main wavelength: 254 nm): the spot obtained from the sample solution, corresponding to that from the standard solution, is not more intense than that from the standard solution.

Loss on drying <2.41> Not more than 0.5% (1 g, 105°C, 2 hours).

Residue on ignition <2.44> Not more than 0.1% (1 g).

Assay Weigh accurately about 0.35 g of Clotrimazole, previously dried, and dissolve in 80 mL of acetic acid (100), and titrate <2.50> with 0.1 mol/L perchloric acid VS (potentiometric titration). Perform a blank determination in the same manner, and make any necessary correction.

$$\begin{aligned} \text{Each mL of 0.1 mol/L perchloric acid VS} \\ = 34.48 \text{ mg of } C_{22}H_{17}ClN_2 \end{aligned}$$

Containers and storage Containers—Well-closed containers.

Storage—Light-resistant.

Cloxacillin Sodium Hydrate

クロキサシリンナトリウム水和物

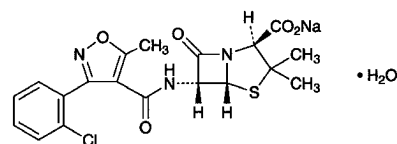

$C_{19}H_{17}ClN_3NaO_5S \cdot H_2O$: 475.88

Monosodium (2*S*,5*R*,6*R*)-6-[[3-(2-chlorophenyl)-5-methylisoxazole-4-carbonyl]amino]-3,3-dimethyl-7-oxo-4-thia-1-azabicyclo[3.2.0]heptane-2-carboxylate monohydrate
[7081-44-9]

Cloxacillin Sodium Hydrate contains not less than 900 μ g (potency) and not more than 960 μ g (potency) per mg, calculated on the anhydrous basis. The potency of Cloxacillin Sodium Hydrate is expressed as mass (potency) of cloxacillin ($C_{19}H_{18}ClN_3O_5S$: 435.88).

Description Cloxacillin Sodium Hydrate occurs as white to light yellow-white, crystals or crystalline powder.

It is freely soluble in water, in *N,N*-dimethylformamide and in methanol, and sparingly soluble in ethanol (95).

Identification (1) Determine the absorption spectrum of a solution of Cloxacillin Sodium Hydrate in methanol (1 in 2500) as directed under Ultraviolet-visible Spectrophotometry <2.24>, and compare the spectrum with the Reference Spectrum or the spectrum of a solution of Cloxacillin Sodium RS prepared in the same manner as the sample solution: both spectra exhibit similar intensities of absorption at the same wavelengths.

(2) Determine the infrared absorption spectrum of Cloxacillin Sodium Hydrate as directed in the potassium bromide disk method under Infrared Spectrophotometry <2.25>, and compare the spectrum with the Reference Spectrum or the spectrum of Cloxacillin Sodium RS: both spectra exhibit similar intensities of absorption at the same wave numbers.

(3) Cloxacillin Sodium Hydrate responds to Qualitative Tests <1.09> (1) for sodium salt.

Optical rotation <2.49> $[\alpha]_D^{20}$: +163 – +171° (1 g calculated on the anhydrous basis, water, 100 mL, 100 mm).

pH <2.54> Dissolve 1.0 g of Cloxacillin Sodium Hydrate in 10 mL of water: the pH of the solution is between 5.0 and 7.5.

Purity (1) Clarity and color of solution—A solution obtained by dissolving 1.0 g of Cloxacillin Sodium Hydrate in 10 mL of water is clear, and its absorbance at 430 nm, determined as directed under Ultraviolet-visible Spectrophotometry <2.24>, is not more than 0.04.

(2) Heavy metals <1.07>—Proceed with 1.0 g of Cloxacillin Sodium Hydrate according to Method 2, and perform the test. Prepare the control solution with 2.0 mL of Standard Lead Solution (not more than 20 ppm).

(3) Arsenic <1.11>—Prepare the test solution with 1.0 g of Cloxacillin Sodium Hydrate according to Method 5, and perform the test (not more than 2 ppm).

(4) Related substances—Dissolve 50 mg of Cloxacillin Sodium Hydrate in 50 mL of the mobile phase, and use this solution as the sample solution. Pipet 1 mL of the sample solution, add the mobile phase to make exactly 100 mL, and use this solution as the standard solution. Perform the test

with exactly 10 μL each of the sample solution and standard solution as directed under Liquid Chromatography <2.01> according to the following conditions, and determine each peak area by the automatic integration method: the area of the peak other than cloxacillin obtained from the sample solution is not larger than the peak area of cloxacillin from the standard solution, and the total area of the peaks other than cloxacillin from the sample solution is not larger than 3 times the peak area of cloxacillin from the standard solution.

Operating conditions—

Detector, column, column temperature, mobile phase, and flow rate: Proceed as directed in the operating conditions in the Assay.

Time span of measurement: About 3 times as long as the retention time of cloxacillin.

System suitability—

Test for required detectability: Pipet 1 mL of the standard solution, and add the mobile phase to make exactly 10 mL. Confirm that the peak area of cloxacillin obtained with 10 μL of this solution is equivalent to 7 to 13% of that with 10 μL of the standard solution.

System performance: When the procedure is run with 10 μL of the standard solution under the above operating conditions, the number of theoretical plates and the symmetry factor of the peak of cloxacillin are not less than 5000 and not more than 1.3, respectively.

System repeatability: When the test is repeated 6 times with 10 μL of the standard solution under the above operating conditions, the relative standard deviation of the peak area of cloxacillin is not more than 1.0%.

Water <2.48> 3.0 – 4.5% (0.2 g, volumetric titration, direct titration).

Assay Weigh accurately an amount of Cloxacillin Sodium Hydrate and Cloxacillin Sodium RS, equivalent to about 50 mg (potency), dissolve each in a suitable amount of the mobile phase, add exactly 5 mL of the internal standard solution, then add the mobile phase to make 50 mL, and use these solutions as the sample solution and the standard solution, respectively. Perform the test with 10 μL each of the sample solution and standard solution as directed under Liquid Chromatography <2.01> according to the following conditions, and calculate the ratios, Q_T and Q_S , of the peak area of cloxacillin to that of the internal standard.

$$\begin{aligned} \text{Amount } [\mu\text{g (potency)}] \text{ of cloxacillin (C}_{19}\text{H}_{18}\text{ClN}_3\text{O}_5\text{S)} \\ = M_S \times Q_T / Q_S \times 1000 \end{aligned}$$

M_S : Amount [mg (potency)] of Cloxacillin Sodium RS taken

Internal standard solution—A solution of guaifenesin in the mobile phase (1 in 200).

Operating conditions—

Detector: An ultraviolet absorption photometer (wavelength: 230 nm).

Column: A stainless steel column 6 mm in inside diameter and 15 cm in length, packed with octadecylsilanized silica gel for liquid chromatography (5 μm in particle diameter).

Column temperature: A constant temperature of about 25°C.

Mobile phase: Dissolve 4.95 g of diammonium hydrogen phosphate in 700 mL of water, add 250 mL of acetonitrile, adjust to pH 4.0 with phosphoric acid, and add water to make 1000 mL.

Flow rate: Adjust so that the retention time of cloxacillin is about 24 minutes.

System suitability—

System performance: When the procedure is run with 10 μL of the standard solution under the above operating conditions, guaifenesin and cloxacillin are eluted in this order with the resolution between these peaks being not less than 25.

System repeatability: When the test is repeated 6 times with 10 μL of the standard solution under the above operating conditions, the relative standard deviation of the ratio of the peak area of cloxacillin to that of the internal standard is not more than 1.0%.

Containers and storage Containers—Tight containers.

Cloxazolam

クロキサゾラム

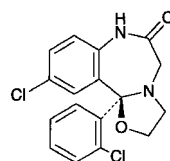

and enantiomer

$\text{C}_{17}\text{H}_{14}\text{Cl}_2\text{N}_2\text{O}_2$: 349.21
(11*bRS*)-10-Chloro-11*b*-(2-chlorophenyl)-2,3,7,11*b*-tetrahydro[1,3]oxazolo[3,2-*d*][1,4]benzodiazepin-6(5*H*)-one
[24166-13-0]

Cloxazolam, when dried, contains not less than 99.0% of cloxazolam ($\text{C}_{17}\text{H}_{14}\text{Cl}_2\text{N}_2\text{O}_2$).

Description Cloxazolam occurs as white, crystals or crystalline powder. It is odorless and tasteless.

It is freely soluble in acetic acid (100), sparingly soluble in dichloromethane, slightly soluble in ethanol (99.5) and in diethyl ether, very slightly soluble in ethanol (95), and practically insoluble in water.

It dissolves in dilute hydrochloric acid.

It is gradually colored by light.

Melting point: about 200°C (with decomposition).

Identification (1) Dissolve 0.01 g of Cloxazolam in 10 mL of ethanol (99.5) by heating, and add 1 drop of hydrochloric acid: the solution shows a light yellow color and a yellow-green fluorescence under ultraviolet light (main wavelength: 365 nm). Add 1 mL of sodium hydroxide TS to this solution: the color and fluorescence of this solution disappear immediately.

(2) Dissolve 0.01 g of Cloxazolam in 5 mL of dilute hydrochloric acid by heating in a water bath for 10 minutes. After cooling, 1 mL of this solution responds to Qualitative Tests <1.09> for primary aromatic amines.

(3) Place 2 g of Cloxazolam in a 200-mL flask, add 50 mL of ethanol (95) and 25 mL of sodium hydroxide TS, and boil under a reflux condenser for 4 hours. After cooling, neutralize with dilute hydrochloric acid, and extract with 30 mL of dichloromethane. Dehydrate with 3 g of anhydrous sodium sulfate, filter, and evaporate the dichloromethane of the filtrate. Dissolve the residue in 5 mL of methanol by heating on a water bath, and cool immediately in an ice bath. Collect the crystals, and dry the crystals in vacuum at 60°C for 1 hour: it melts <2.60> between 87°C and 91°C.

(4) Determine the absorption spectrum of a solution of Cloxazolam in ethanol (99.5) (1 in 100,000) as directed under Ultraviolet-visible Spectrophotometry <2.24>, and compare

the spectrum with the Reference Spectrum: both spectra exhibit similar intensities of absorption at the same wavelengths.

(5) Proceed with Cloxazolam as directed under Flame Coloration Test <1.04> (2), and perform the test: a green color appears.

Absorbance <2.24> $E_{1\text{cm}}^{1\%}$ (244 nm): 390 – 410 (after drying, 1 mg, ethanol (99.5), 100 mL).

Purity (1) Chloride <1.03>—To 1.0 g of Cloxazolam add 50 mL of water, allow to stand for 1 hour with occasional shaking, and filter. To 25 mL of this filtrate add 6 mL of dilute nitric acid and water to make 50 mL, and perform the test using this solution as the test solution. Prepare the control solution with 0.20 mL of 0.01 mol/L hydrochloric acid VS (not more than 0.014%).

(2) Heavy metals <1.07>—Proceed with 1.0 g of Cloxazolam according to Method 2, and perform the test. Prepare the control solution with 2.0 mL of Standard Lead Solution (not more than 20 ppm).

(3) Arsenic <1.11>—Place 1.0 g of Cloxazolam in a Kjeldahl flask, add 5 mL of sulfuric acid and 5 mL of nitric acid, and heat gently. Repeat the addition of 2 to 3 mL of nitric acid at times, and continue heating until a colorless to light yellow solution is obtained. After cooling, add 15 mL of saturated ammonium oxalate solution, and heat the solution until dense white fumes are evolved, and evaporate to a volume of 2 to 3 mL. After cooling, dilute with water to 10 mL, and perform the test with this solution as the test solution (not more than 2 ppm).

(4) Related substances—Dissolve 0.05 g of Cloxazolam in 10 mL of dichloromethane, and use this solution as the sample solution. Pipet 1 mL of the sample solution, add dichloromethane to make exactly 200 mL, and use this solution as the standard solution. Perform the test with these solutions as directed under Thin-layer Chromatography <2.03>. Spot 10 μL each of the sample solution and standard solution on a plate of silica gel with fluorescent indicator for thin-layer chromatography. Immediately after air-drying, develop the plate with a mixture of toluene and acetone (5:1) to a distance of about 10 cm, and air-dry the plate. Examine under ultraviolet light (main wavelength: 254 nm): the spots other than the principal spot from the sample solution are not more intense than that from the standard solution.

Loss on drying <2.41> Not more than 0.5% (1 g, 105°C, 3 hours).

Residue on ignition <2.44> Not more than 0.1% (1 g).

Assay Weigh accurately about 0.5 g of Cloxazolam, previously dried, and dissolve in 50 mL of acetic acid (100). Titrate <2.50> with 0.1 mol/L perchloric acid VS until the color of the solution changes from purple through blue to blue-green (indicator: 2 drops of crystal violet TS). Perform a blank determination in the same manner, and make any necessary correction.

Each mL of 0.1 mol/L perchloric acid VS
= 34.92 mg of $\text{C}_{17}\text{H}_{14}\text{Cl}_2\text{N}_2\text{O}_2$

Containers and storage Containers—Tight containers.

Storage—Light-resistant.

Cocaine Hydrochloride

コカイン塩酸塩

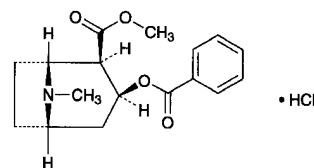

$\text{C}_{17}\text{H}_{21}\text{NO}_4 \cdot \text{HCl}$: 339.81

(1*R*,2*R*,3*S*,5*S*)-2-Methoxycarbonyl-8-methyl-8-azabicyclo[3.2.1]oct-3-yl benzoate monohydrochloride [53-21-4]

Cocaine Hydrochloride, when dried, contains not less than 98.0% of cocaine hydrochloride ($\text{C}_{17}\text{H}_{21}\text{NO}_4 \cdot \text{HCl}$).

Description Cocaine Hydrochloride occurs as colorless crystals or a white crystalline powder.

It is very soluble in water, freely soluble in ethanol (95) and in acetic acid (100), slightly soluble in acetic anhydride, and practically insoluble in diethyl ether.

Identification (1) Determine the absorption spectrum of a solution of Cocaine Hydrochloride in 0.01 mol/L hydrochloric acid TS (1 in 10,000) as directed under Ultraviolet-visible Spectrophotometry <2.24>, and compare the spectrum with the Reference Spectrum 1: both spectra exhibit similar intensities of absorption at the same wavelengths. Separately, determine the absorption spectrum of a solution of Cocaine Hydrochloride in 0.01 mol/L hydrochloric acid TS (1 in 50,000) as directed under Ultraviolet-visible Spectrophotometry <2.24>, and compare the spectrum with the Reference Spectrum 2: both spectra exhibit similar intensities of absorption at the same wavelengths.

(2) Determine the infrared absorption spectrum of Cocaine Hydrochloride, previously dried, as directed in the potassium bromide disk method under the Infrared Spectrophotometry <2.25>, and compare the spectrum with the Reference Spectrum: both spectra exhibit similar intensities of absorption at the same wave numbers.

(3) A solution of Cocaine Hydrochloride (1 in 50) responds to Qualitative Tests <1.09> (2) for chloride.

Optical rotation <2.49> $[\alpha]_{\text{D}}^{20}$: -70 – -73° (after drying, 0.5 g, water, 20 mL, 100 mm).

Purity (1) Acidity—Dissolve 0.5 g of Cocaine Hydrochloride in 10 mL of water, add 1 drop of methyl red TS, and neutralize with 0.01 mol/L sodium hydroxide VS: the consumed volume is not more than 1.0 mL.

(2) Cinnamyl cocaine—Dissolve 0.10 g of Cocaine Hydrochloride in 5 mL of water, and add 0.3 mL of diluted sulfuric acid (1 in 20) and 0.10 mL of 0.02 mol/L potassium permanganate VS: the red color does not disappear within 30 minutes.

(3) Isoatropyl cocaine—Dissolve 0.10 g of Cocaine Hydrochloride in 30 mL of water in a beaker. Transfer 5 mL of this solution to a test tube, add 1 drop of ammonia TS, and mix. After the precipitate is coagulated, add 10 mL of water, and transfer the mixture to the former beaker, to which 30 mL of water has been added previously. Wash the test tube with 10 mL of water, combine the washings with the mixture in the beaker, add 3 drops of ammonia TS to the combined mixture, and mix gently: a crystalline precipitate is produced. Allow to stand for 1 hour: the supernatant liquid is

clear.

Loss on drying <2.41> Not more than 1.0% (1 g, 105°C, 4 hours).

Residue on ignition <2.44> Not more than 0.1% (0.5 g).

Assay Weigh accurately about 0.5 g of Cocaine Hydrochloride, previously dried, dissolve in 50 mL of a mixture of acetic anhydride and acetic acid (100) (7:3), and titrate <2.50> with 0.1 mol/L perchloric acid VS (potentiometric titration). Perform a blank determination in the same manner, and make any necessary correction.

Each mL of 0.1 mol/L perchloric acid VS
= 33.98 mg of $C_{17}H_{21}NO_4 \cdot HCl$

Containers and storage Containers—Tight containers.
Storage—Light-resistant.

Cod Liver Oil

肝油

Cod Liver Oil is the fatty oils obtained from fresh livers and pyloric appendages of *Gadus macrocephalus* Tilesius or *Theragra chalcogramma* Pallas (*Gadidae*).

Cod Liver Oil contains not less than 2000 Vitamin A Units and not more than 5000 Vitamin A Units per g.

Description Cod Liver Oil is a yellow to orange oily liquid. It has a characteristic, slightly fishy odor and a mild taste.

It is miscible with chloroform.

It is slightly soluble in ethanol (95), and practically insoluble in water.

It is decomposed by air or by light.

Identification Dissolve 0.1 g of Cod Liver Oil in 10 mL of chloroform, and to 1 mL of this solution add 3 mL of antimony (III) chloride TS: a blue color develops immediately, but the color fades rapidly.

Specific gravity <1.13> d_{20}^{20} : 0.918 – 0.928

Acid value <1.13> Not more than 1.7.

Saponification value <1.13> 180 – 192

Unsaponifiable matter <1.13> Not more than 3.0%.

Iodine value <1.13> 130 – 170

Purity Rancidity—No unpleasant odor of rancid oil is perceptible on warming Cod Liver Oil.

Assay Proceed with about 0.5 g of Cod Liver Oil, accurately weighed, as directed in Method 2 under the Vitamin A Determination <2.55>, and perform the test.

Containers and storage Containers—Tight containers.

Storage—Light-resistant, and almost well-filled, or under nitrogen atmosphere.

Codeine Phosphate Hydrate

コデインリン酸塩水和物

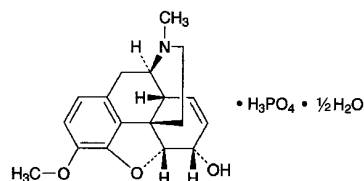

$C_{18}H_{21}NO_3 \cdot H_3PO_4 \cdot \frac{1}{2}H_2O$: 406.37
(5*R*,6*S*)-4,5-Epoxy-3-methoxy-17-methyl-7,8-didehydromorphinan-6-ol monophosphate hemihydrate
[41444-62-6]

Codeine Phosphate Hydrate contains not less than 98.0% of codeine phosphate ($C_{18}H_{21}NO_3 \cdot H_3PO_4$: 397.36), calculated on the anhydrous basis.

Description Codeine Phosphate Hydrate occurs as white to yellowish white, crystals or crystalline powder.

It is freely soluble in water and in acetic acid (100), slightly soluble in methanol and in ethanol (95), and practically insoluble in diethyl ether.

The pH of a solution of 1.0 g of Codeine Phosphate Hydrate in 10 mL of water is between 3.0 and 5.0.

It is affected by light.

Identification (1) Determine the absorption spectrum of a solution of Codeine Phosphate Hydrate (1 in 10,000) as directed under Ultraviolet-visible Spectrophotometry <2.24>, and compare the spectrum with the Reference Spectrum: both spectra exhibit similar intensities of absorption at the same wavelengths.

(2) Determine the infrared absorption spectrum of Codeine Phosphate Hydrate, previously dried at 105°C for 4 hours, as directed in the potassium bromide disk method under Infrared Spectrophotometry <2.25>, and compare the spectrum with the Reference Spectrum: both spectra exhibit similar intensities of absorption at the same wave numbers.

(3) A solution of Codeine Phosphate Hydrate (1 in 20) responds to Qualitative Tests <1.09> (1) for phosphate.

Optical rotation <2.49> $[\alpha]_D^{20}$: $-98 - -102^\circ$ (0.4 g calculated on the anhydrous basis, water, 20 mL, 100 mm).

Purity (1) Chloride <1.03>—Perform the test with 0.5 g of Codeine Phosphate Hydrate. Prepare the control solution with 0.30 mL of 0.01 mol/L hydrochloric acid VS (not more than 0.021%).

(2) Sulfate <1.14>—Perform the test with 0.20 g of Codeine Phosphate Hydrate. Prepare the control solution with 1.0 mL of 0.005 mol/L sulfuric acid VS (not more than 0.240%).

(3) Related substances—Dissolve 0.20 g of Codeine Phosphate Hydrate in 10 mL of a mixture of 0.01 mol/L hydrochloric acid TS and ethanol (99.5) (4:1), and use this solution as the sample solution. Pipet 1 mL of the sample solution, add a mixture of 0.01 mol/L hydrochloric acid TS and ethanol (99.5) (4:1) to make exactly 100 mL, and use this solution as the standard solution. Perform the test with these solutions as directed under Thin-layer Chromatography <2.03>. Spot 10 μ L each of the sample solution and standard solution on a plate of silica gel with fluorescent indicator for thin-layer chromatography. Develop the plate with a mixture of ethanol (99.5), toluene, acetone and ammonia solution (28) (14:14:7:1) to a distance of about 10 cm, and air-dry the

plate. Examine under ultraviolet light (main wavelength: 254 nm): the spots other than the principal spot obtained from the sample solution are not more intense than the spot from the standard solution.

Water <2.48> 1.5 – 3.0% (0.5 g, volumetric titration, direct titration).

Assay Dissolve about 0.5 g of Codeine Phosphate Hydrate, accurately weighed, in 70 mL of acetic acid (100), and titrate <2.50> with 0.1 mol/L perchloric acid VS until the color of the solution changes from purple through blue to greenish blue (indicator: 3 drops of crystal violet TS). Perform a blank determination in the same manner, and make any necessary correction.

Each mL of 0.1 mol/L perchloric acid VS
= 39.74 mg of $C_{18}H_{21}NO_3 \cdot H_3PO_4$

Containers and storage Containers—Tight containers.
Storage—Light-resistant.

1% Codeine Phosphate Powder

コデインリン酸塩散 1%

1% Codeine Phosphate Powder contains not less than 0.90% and not more than 1.10% of codeine phosphate hydrate ($C_{18}H_{21}NO_3 \cdot H_3PO_4 \cdot \frac{1}{2}H_2O$; 406.37).

Method of preparation

Codeine Phosphate Hydrate	10 g
Lactose Hydrate	a sufficient quantity
To make 1000 g	

Prepare as directed under Granules or Powders, with the above ingredients.

Identification Determine the absorption spectrum of a solution of 1% Codeine Phosphate Powder (1 in 100) as directed under Ultraviolet-visible Spectrophotometry <2.24>: it exhibits a maximum between 283 nm and 287 nm.

Dissolution <6.10> When the test is performed at 50 revolutions per minute according to the Paddle method, using 900 mL of water as the dissolution medium, the dissolution rate in 15 minutes of 1% Codeine Phosphate Powder is not less than 85%.

Start the test with about 2 g of 1% Codeine Phosphate Powder, accurately weighed, withdraw not less than 20 mL of the medium at the specified minute after starting the test, and filter through a membrane filter with a pore size not exceeding 0.45 μ m. Discard not less than 10 mL of the first filtrate, and use the subsequent filtrate as the sample solution. Separately, weigh accurately about 28 mg of codeine phosphate hydrate for assay (separately determine the water <2.48> in the same manner as Codeine Phosphate Hydrate), and dissolve in water to make exactly 100 mL. Pipet 4 mL of this solution, add water to make exactly 50 mL, and use this solution as the standard solution. Perform the test with exactly 50 μ L each of the sample solution and standard solution as directed under Liquid Chromatography <2.01> according to the following conditions, and determine the peak areas, A_T and A_S , of codeine in each solution.

Dissolution rate (%) with respect to the labeled amount of codeine phosphate hydrate ($C_{18}H_{21}NO_3 \cdot H_3PO_4 \cdot \frac{1}{2}H_2O$)
= $M_S/M_T \times A_T/A_S \times 36/5 \times 1.023$

M_S : Amount (mg) of codeine phosphate hydrate for assay taken, calculated on the anhydrous basis

M_T : Amount (g) of 1% Codeine Phosphate Powder taken

Operating conditions—

Proceed as directed in the operating conditions in the Assay.

System suitability—

System performance: When the procedure is run with 50 μ L of the standard solution under the above operating conditions, the number of theoretical plates and the symmetry factor of the peak of codeine are not less than 3000 and not more than 2.0, respectively.

System repeatability: When the test is repeated 6 times with 50 μ L of the standard solution under the above operating conditions, the relative standard deviation of the peak area of codeine is not more than 2.0%.

Assay Weigh accurately about 5 g of 1% Codeine Phosphate Powder, dissolve in water to make exactly 100 mL, then pipet 10 mL of this solution, add exactly 10 mL of the internal standard solution, and use this solution as the sample solution. Separately, weigh accurately about 50 mg of codeine phosphate hydrate for assay (previously determine the water <2.48> in the same manner as Codeine Phosphate Hydrate), dissolve in water to make exactly 100 mL, then pipet 10 mL of this solution, add exactly 10 mL of the internal standard solution, and use this solution as the standard solution. Perform the test with 20 μ L each of the sample solution and standard solution as directed under Liquid Chromatography <2.01> according to the following conditions, and calculate the ratios, Q_T and Q_S , of the peak area of codeine to that of the internal standard.

Amount (mg) of codeine phosphate hydrate
($C_{18}H_{21}NO_3 \cdot H_3PO_4 \cdot \frac{1}{2}H_2O$)
= $M_S \times Q_T/Q_S \times 1.023$

M_S : Amount (mg) of codeine phosphate hydrate for assay taken, calculated on the anhydrous basis

Internal standard solution—A solution of etilefrine hydrochloride (3 in 10,000).

Operating conditions—

Detector: An ultraviolet absorption photometer (wavelength: 280 nm).

Column: A stainless steel column 4.6 mm in inside diameter and 15 cm in length, packed with octadecylsilanized silica gel for liquid chromatography (5 μ m in particle diameter).

Column temperature: A constant temperature of about 40°C.

Mobile phase: Dissolve 1.0 g of sodium lauryl sulfate in 500 mL of diluted phosphoric acid (1 in 1000), and adjust the pH to 3.0 with sodium hydroxide TS. To 240 mL of this solution add 70 mL of tetrahydrofuran, and mix.

Flow rate: Adjust so that the retention time of codeine is about 10 minutes.

System suitability—

System performance: When the procedure is run with 20 μ L of the standard solution under the above operating conditions, codeine and the internal standard are eluted in this order with the resolution between these peaks being not less than 4.

System repeatability: When the test is repeated 5 times with 20 μ L of the standard solution under the above operating conditions, the relative standard deviation of the ratio of the peak area of codeine to that of the internal standard is not more than 1.0%.

Containers and storage Containers—Tight containers.

10% Codeine Phosphate Powder

コデインリン酸塩散 10%

10% Codeine Phosphate Powder contains not less than 9.3% and not more than 10.7% of codeine phosphate hydrate ($C_{18}H_{21}NO_3 \cdot H_3PO_4 \cdot \frac{1}{2}H_2O$: 406.37).

Method of preparation

Codeine Phosphate Hydrate	100 g
Lactose Hydrate	a sufficient quantity
To make 1000 g	

Prepare as directed under Powders, with the above ingredients.

Identification Determine the absorption spectrum of a solution of 10% Codeine Phosphate Powder (1 in 1000) as directed under Ultraviolet-visible Spectrophotometry <2.24>: it exhibits a maximum between 283 nm and 287 nm.

Dissolution <6.10> When the test is performed at 50 revolutions per minute according to the Paddle method, using 900 mL of water as the dissolution medium, the dissolution rate in 15 minutes of 10% Codeine Phosphate Powder is not less than 85%.

Start the test with about 0.2 g of 10% Codeine Phosphate Powder, accurately weighed, withdraw not less than 20 mL of the medium at the specified minute after starting the test, and filter through a membrane filter with a pore size not exceeding $0.45 \mu\text{m}$. Discard not less than 10 mL of the first filtrate, and use the subsequent filtrate as the sample solution. Separately, weigh accurately about 28 mg of codeine phosphate hydrate for assay (separately determine the water <2.48> in the same manner as Codeine Phosphate Hydrate), and dissolve in water to make exactly 100 mL. Pipet 4 mL of this solution, add water to make exactly 50 mL, and use this solution as the standard solution. Perform the test with exactly $50 \mu\text{L}$ each of the sample solution and standard solution as directed under Liquid Chromatography <2.01> according to the following conditions, and determine the peak areas, A_T and A_S , of codeine in each solution.

Dissolution rate (%) with respect to the labeled amount of codeine phosphate hydrate ($C_{18}H_{21}NO_3 \cdot H_3PO_4 \cdot \frac{1}{2}H_2O$)

$$= M_S/M_T \times A_T/A_S \times 18/25 \times 1.023$$

M_S : Amount (mg) of codeine phosphate hydrate for assay taken, calculated on the anhydrous basis

M_T : Amount (g) of 10% Codeine Phosphate Powder

Operating conditions—

Proceed as directed in the operating conditions in the Assay.

System suitability—

System performance: When the procedure is run with 50 μL of the standard solution under the above operating conditions, the number of theoretical plates and the symmetry factor of the peak of codeine are not less than 3000 and not more than 2.0, respectively.

System repeatability: When the test is repeated 6 times with 50 μL of the standard solution under the above operating conditions, the relative standard deviation of the peak area of codeine is not more than 2.0%.

Assay Weigh accurately about 2.5 g of 10% Codeine Phosphate Powder, dissolve in water to make exactly 100 mL, then pipet 2 mL of this solution, add exactly 10 mL of the in-

ternal standard solution and water to make 20 mL, and use this solution as the sample solution. Separately, weigh accurately about 50 mg of codeine phosphate hydrate for assay (previously determine the water <2.48> in the same manner as Codeine Phosphate Hydrate), dissolve in water to make exactly 100 mL, then pipet 10 mL of this solution, add exactly 10 mL of the internal standard solution, and use this solution as the standard solution. Perform the test with 20 μL each of the sample solution and standard solution as directed under Liquid Chromatography <2.01> according to the following conditions, and calculate the ratios, Q_T and Q_S , of the peak area of codeine to that of the internal standard:

$$\begin{aligned} &\text{Amount (mg) of codeine phosphate hydrate} \\ &(C_{18}H_{21}NO_3 \cdot H_3PO_4 \cdot \frac{1}{2}H_2O) \\ &= M_S \times Q_T/Q_S \times 5 \times 1.023 \end{aligned}$$

M_S : Amount (mg) of codeine phosphate hydrate for assay taken, calculated on the anhydrous basis

Internal standard solution—A solution of etilefrine hydrochloride (3 in 10,000).

Operating conditions—

Detector: An ultraviolet absorption photometer (wavelength: 280 nm).

Column: A stainless steel column 4.6 mm in inside diameter and 15 cm in length, packed with octadecylsilanized silica gel for liquid chromatography ($5 \mu\text{m}$ in particle diameter).

Column temperature: A constant temperature of about 40°C .

Mobile phase: Dissolve 1.0 g of sodium lauryl sulfate in 500 mL of diluted phosphoric acid (1 in 1000), and adjust the pH to 3.0 with sodium hydroxide TS. To 240 mL of this solution add 70 mL of tetrahydrofuran, and mix.

Flow rate: Adjust so that the retention time of codeine is about 10 minutes.

System suitability—

System performance: When the procedure is run with 20 μL of the standard solution under the above operating conditions, codeine and the internal standard are eluted in this order with the resolution between these peaks being not less than 4.

System repeatability: When the test is repeated 5 times with 20 μL of the standard solution under the above operating conditions, the relative standard deviation of the ratios of the peak area of codeine to that of the internal standard is not more than 1.0%.

Containers and storage Containers—Tight containers.

Codeine Phosphate Tablets

コデインリン酸塩錠

Codeine Phosphate Tablets contain not less than 93.0% and not more than 107.0% of the labeled amount of codeine phosphate hydrate ($C_{18}H_{21}NO_3 \cdot H_3PO_4 \cdot \frac{1}{2}H_2O$: 406.37)

Method of preparation Prepare as directed under Tablets, with Codeine Phosphate Hydrate.

Identification To a quantity of powdered Codeine Phosphate Tablets, equivalent to 0.1 g of Codeine Phosphate Hydrate, add 20 mL of water, shake, and filter. To 2 mL of the filtrate add water to make 100 mL, and determine the absorption spectrum as directed under Ultraviolet-visible Spectrophotometry <2.24>: it exhibits a maximum between

283 nm and 287 nm.

Uniformity of dosage units <6.02> Perform the test according to the following method: it meets the requirement of the Content uniformity test.

To 1 tablet of Codeine Phosphate Tablets add 3V/25 mL of water to disintegrate, add 2V/25 mL of diluted dilute sulfuric acid (1 in 20), and sonicate for 10 minutes. To this solution add exactly 2V/25 mL of the internal standard solution, add water to make V mL so that each mL contains about 0.2 mg of codeine phosphate hydrate ($C_{18}H_{21}NO_3 \cdot H_3PO_4 \cdot \frac{1}{2}H_2O$), filter, and use the filtrate as the sample solution. Separately, weigh accurately about 50 mg of codeine phosphate hydrate for assay (separately, determine the water <2.48> in the same manner as Codeine Phosphate Hydrate), and dissolve in water to make exactly 100 mL. Pipet 10 mL of this solution, add exactly 2 mL of the internal standard solution, add water to make 25 mL, and use this solution as the standard solution. Proceed as directed in the Assay.

$$\begin{aligned} & \text{Amount (mg) of codeine phosphate hydrate} \\ & (C_{18}H_{21}NO_3 \cdot H_3PO_4 \cdot \frac{1}{2}H_2O) \\ & = M_S \times Q_T/Q_S \times V/250 \times 1.023 \end{aligned}$$

M_S : Amount (mg) of codeine phosphate hydrate for assay taken, calculated on the anhydrous basis

Internal standard solution—A solution of ethylefrin hydrochloride (3 in 2000).

Dissolution <6.10> When the test is performed at 50 revolutions per minute according to the Paddle method, using 900 mL of water as the dissolution medium, the dissolution rate in 30 minutes of Codeine Phosphate Tablets is not less than 80%.

Start the test with 1 tablet of Codeine Phosphate Tablets, withdraw not less than 20 mL of the medium at the specified minute after starting the test, and filter through a membrane filter with a pore size not exceeding 0.45 μ m. Discard not less than 10 mL of the first filtrate, pipet V mL of the subsequent filtrate, add water to make exactly V' mL so that each mL contains about 5.6 μ g of codeine phosphate hydrate ($C_{18}H_{21}NO_3 \cdot H_3PO_4 \cdot \frac{1}{2}H_2O$), and use this solution as the sample solution. Separately, weigh accurately about 28 mg of codeine phosphate hydrate for assay (separately, determine the water <2.48> in the same manner as Codeine Phosphate Hydrate), dissolve in water to make exactly 100 mL. Pipet 2 mL of this solution, add water to make exactly 100 mL, and use this solution as the standard solution. Perform the test with exactly 100 μ L each of the sample solution and standard solution as directed under Liquid Chromatography <2.01> according to the following conditions, and determine the peak areas, A_T and A_S , of codeine in each solution.

Dissolution rate (%) with respect to the labeled amount of codeine phosphate hydrate ($C_{18}H_{21}NO_3 \cdot H_3PO_4 \cdot \frac{1}{2}H_2O$)

$$= M_S \times A_T/A_S \times V'/V \times 1/C \times 18 \times 1.023$$

M_S : Amount (mg) of codeine phosphate hydrate for assay taken, calculated on the anhydrous basis

C: Labeled amount (mg) of codeine phosphate hydrate ($C_{18}H_{21}NO_3 \cdot H_3PO_4 \cdot \frac{1}{2}H_2O$) in 1 tablet

Operating conditions—

Proceed as directed in the operating conditions in the Assay.

System suitability—

System performance: When the procedure is run with 100 μ L of the standard solution under the above operating conditions, the number of theoretical plates and the symmetry

factor of the peak of codeine are not less than 5000 and not more than 1.5, respectively.

System repeatability: When the test is repeated 6 times with 100 μ L of the standard solution under the above operating conditions, the relative standard deviation of the peak area of codeine is not more than 2.0%.

Assay Weigh accurately and powder not less than 20 Codeine Phosphate Tablets. Weigh accurately a portion of the powder, equivalent to about 0.1 g of codeine phosphate hydrate ($C_{18}H_{21}NO_3 \cdot H_3PO_4 \cdot \frac{1}{2}H_2O$), add 30 mL of water, shake, add 20 mL of diluted dilute sulfuric acid (1 in 20), sonicate the mixture for 10 minutes, and add water to make exactly 100 mL. Filter the solution, then pipet 5 mL of the filtrate, add exactly 10 mL of the internal standard solution and water to make 20 mL, and use this solution as the sample solution. Separately, weigh accurately about 50 mg of codeine phosphate hydrate for assay (previously determine the water <2.48> in the same manner as Codeine Phosphate Hydrate), dissolve in water to make exactly 100 mL, then pipet 10 mL of this solution, add exactly 10 mL of the internal standard solution, and use this solution as the standard solution. Perform the test with 20 μ L each of the sample solution and standard solution as directed under Liquid Chromatography <2.01> according to the following conditions, and calculate the ratios, Q_T and Q_S , of the peak area of codeine to that of the internal standard.

$$\begin{aligned} & \text{Amount (mg) of codeine phosphate hydrate} \\ & (C_{18}H_{21}NO_3 \cdot H_3PO_4 \cdot \frac{1}{2}H_2O) \\ & = M_S \times Q_T/Q_S \times 2 \times 1.023 \end{aligned}$$

M_S : Amount (mg) of codeine phosphate hydrate for assay taken, calculated on the anhydrous basis

Internal standard solution—A solution of etilefrin hydrochloride (3 in 10,000).

Operating conditions—

Detector: An ultraviolet absorption photometer (wavelength: 280 nm).

Column: A stainless steel column 4.6 mm in inside diameter and 15 cm in length, packed with octadecylsilanized silica gel for liquid chromatography (5 μ m in particle diameter).

Column temperature: A constant temperature of about 40°C.

Mobile phase: Dissolve 1.0 g of sodium lauryl sulfate in 500 mL of diluted phosphoric acid (1 in 1000), and adjust the pH to 3.0 with sodium hydroxide TS. To 240 mL of this solution add 70 mL of tetrahydrofuran, and mix.

Flow rate: Adjust so that the retention time of codeine is about 10 minutes.

System suitability—

System performance: When the procedure is run with 20 μ L of the standard solution under the above operating conditions, codeine and the internal standard are eluted in this order with the resolution between these peaks being not less than 4.

System repeatability: When the test is repeated 5 times with 20 μ L of the standard solution under the above operating conditions, the relative standard deviation of the ratios of the peak area of codeine to that of the internal standard is not more than 1.0%.

Containers and storage Containers—Tight containers.

Colchicine

コルヒチン

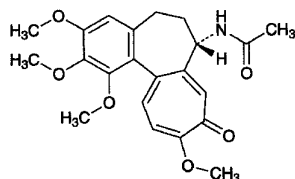

$C_{22}H_{25}NO_6$: 399.44

N-[(7*S*)-(1,2,3,10-Tetramethoxy-9-oxo-5,6,7,9-tetrahydrobenzo[*a*]heptalen-7-yl)]acetamide [64-86-8]

Colchicine contains not less than 97.0% and not more than 102.0% of colchicine ($C_{22}H_{25}NO_6$), calculated on the anhydrous and residual ethyl acetate-free basis.

Description Colchicine occurs as a yellowish white powder.

It is very soluble in methanol, freely soluble in *N,N*-dimethylformamide, in ethanol (95) and in acetic anhydride, and sparingly soluble in water.

It is colored by light.

Identification (1) Determine the absorption spectrum of a solution of Colchicine in ethanol (95) (1 in 100,000) as directed under Ultraviolet-visible Spectrophotometry <2.24>, and compare the spectrum with the Reference Spectrum: both spectra exhibit similar intensities of absorption at the same wavelengths.

(2) To 1 g of potassium bromide for infrared absorption spectrum add 0.5 mL of a solution of Colchicine in methanol (1 in 50), grind thoroughly, and dry in vacuum at 80°C for 1 hour. Determine the infrared absorption spectrum of this powder as directed in the potassium bromide disk method under Infrared Spectrophotometry <2.25>, and compare the spectrum with the Reference Spectrum: both spectra exhibit similar intensities of absorption at the same wave numbers.

Optical rotation <2.49> $[\alpha]_D^{20}$: $-235 - -250^\circ$ (0.1 g calculated on the anhydrous basis and corrected by the amount of ethyl acetate, ethanol (95), 10 mL, 100 mm).

Purity (1) Colchicine—Dissolve 0.10 g of Colchicine in 10 mL of water, and to 5 mL of this solution add 2 drops of iron (III) chloride TS: no definite green color develops.

(2) Chloroform and ethyl acetate—Weigh accurately about 0.6 g of Colchicine, dissolve in exactly 2 mL of the internal standard solution, add *N,N*-dimethylformamide to make 10 mL, and use this solution as the sample solution. Separately, weigh 0.30 g of chloroform using a 100-mL volumetric flask containing about 20 mL of *N,N*-dimethylformamide, and add *N,N*-dimethylformamide to make exactly 100 mL. Pipet 2 mL of this solution, add *N,N*-dimethylformamide to make exactly 200 mL, and use this solution as the standard solution (1). Separately, weigh accurately about 1.8 g of ethyl acetate using a 100-mL volumetric flask containing about 20 mL of *N,N*-dimethylformamide, and add *N,N*-dimethylformamide to make exactly 100 mL. Pipet 2 mL of this solution, add exactly 2 mL of the internal standard solution and *N,N*-dimethylformamide to make 10 mL, and use this solution as the standard solution (2). Perform the test with exactly 2 μ L each of the sample solution and standard solutions (1) and (2) as directed under Gas Chromatography <2.02> according to the following conditions:

the peak area of chloroform obtained from sample solution is not larger than that from the standard solution (1). Calculate the ratios of the peak area of ethyl acetate to that of the internal standard, Q_T and Q_S , of the sample solution and standard solution (2), and calculate the amount of ethyl acetate by the following formula: the amount of ethyl acetate is not more than 6.0%.

$$\begin{aligned} \text{Amount (\%)} \text{ of ethyl acetate (C}_4\text{H}_8\text{O}_2\text{)} \\ = M_S/M_T \times Q_T/Q_S \times 2 \end{aligned}$$

M_S : Amount (g) of ethyl acetate taken

M_T : Amount (g) of Colchicine taken

Internal standard solution—A solution of 1-propanol in *N,N*-dimethylformamide (3 in 200).

Operating conditions—

Detector: A hydrogen flame-ionization detector.

Column: A fused silica column 0.53 mm in inside diameter and 30 m in length, coated inside surface with polyethylene glycol 20 M for gas chromatography 1.0 μ m in thickness.

Column temperature: 60°C for 7 minutes, then up to 100°C at a rate of 40°C per minute if necessary, and hold at 100°C for 10 minutes.

Injection port temperature: A constant temperature of about 130°C.

Detector temperature: A constant temperature of about 200°C.

Carrier gas: Helium.

Flow rate: Adjust so that the retention time of ethyl acetate is about 3 minutes.

Split ratio: 1:20.

System suitability—

Test for required detectability: Pipet 2 mL of the standard solution (2), and add *N,N*-dimethylformamide to make exactly 25 mL. Pipet 1 mL of this solution, and add *N,N*-dimethylformamide to make exactly 50 mL. Confirm that the peak area of ethyl acetate obtained with 2 μ L of this solution is equivalent to 0.11 to 0.21% of that with 2 μ L of the standard solution (2).

System performance: To 1 mL of chloroform add *N,N*-dimethylformamide to make 10 mL. To 1 mL of this solution add 2 mL of ethyl acetate and *N,N*-dimethylformamide to make 100 mL. To 2 mL of this solution add 2 mL of the internal standard solution and *N,N*-dimethylformamide to make 10 mL. When the procedure is run with 2 μ L of this solution under the above operating conditions, ethyl acetate, chloroform and the internal standard are eluted in this order with the resolution between the peaks of chloroform and the internal standard being not less than 2.0.

System repeatability: When the test is repeated 3 times with 2 μ L of the standard solution (2) under the above operating conditions, the relative standard deviation of the ratio of the peak area of ethyl acetate to that of the internal standard is not more than 3.0%.

(3) Related substances—Dissolve 60 mg of Colchicine in 100 mL of diluted methanol (1 in 2). To 1 mL of this solution, add diluted methanol (1 in 2) to make 100 mL, and use this solution as the sample solution. Perform the test with 20 μ L of the sample solution as directed under Liquid Chromatography <2.01> according to the following conditions, and determine each peak area by the automatic integration method. Calculate the total amount of the peaks other than colchicine by the area percentage method: not more than 5.0%.

Operating conditions—

Detector: An ultraviolet absorption photometer (wavelength: 254 nm).

Column: A stainless steel column 4.6 mm in inside diameter and 25 cm in length, packed with octylsilanized silica gel for liquid chromatography (5 μ m in particle diameter).

Column temperature: A constant temperature of about 25°C.

Mobile phase: To 450 mL of 0.05 mol/L potassium dihydrogen phosphate TS add methanol to make 1000 mL. Adjust the pH to 5.5 with diluted phosphoric acid (7 in 200).

Flow rate: Adjust so that the retention time of colchicine is about 7 minutes.

Time span of measurement: About 2 times as long as the retention time of colchicine, beginning after the solvent peak.

System suitability—

Test for required detectability: Pipet 1 mL of the sample solution, and add diluted methanol (1 in 2) to make exactly 50 mL. Confirm that the peak area of colchicine obtained from 20 μ L of this solution is equivalent to 1.4 to 2.6% of that obtained from 20 μ L of the sample solution.

System performance: When the procedure is run with 20 μ L of the sample solution under the above operating conditions, the number of theoretical plates and the symmetry factor of the peak of colchicine are not less than 6000 and not more than 1.5, respectively.

System repeatability: When the test is repeated 6 times with 20 μ L of the sample solution under the above operating conditions, the relative standard deviation of the peak area of colchicine is not more than 2.0%.

Water <2.48> Not more than 2.0% (0.5 g, volumetric titration, back titration).

Assay Weigh accurately about 0.4 g of Colchicine, dissolve in 25 mL of acetic anhydride, and titrate <2.50> with 0.05 mol/L perchloric acid VS (potentiometric titration). Perform a blank determination in the same manner, and make any necessary correction.

Each mL of 0.05 mol/L perchloric acid VS
= 19.97 mg of C₂₂H₂₅NO₆

Containers and storage Containers—Tight containers.
Storage—Light-resistant.

Colestimide

コレステミド

[95522-45-5]

Colestimide is an anion exchange resin, composed of a copolymer of 2-methylimidazole and 1-chloro-2,3-epoxypropane.

It contains not less than 18.0% and not more than 20.0% of chlorine (Cl: 35.45), calculated on the dried basis.

Each g of Colestimide, calculated on the dried basis, exchanges with not less than 2.0 g and not more than 2.4 g of cholic acid (C₂₄H₃₉O₅: 407.56).

Description Colestimide occurs as a white to pale yellow-white powder.

It is practically insoluble in water and in ethanol (99.5).
It is hygroscopic.

Identification Determine the infrared absorption spectrum of Colestimide, previously dried, as directed in the potassium chloride disk method under Infrared Spectrophotometry <2.25>, and compare the spectrum with the Reference

Spectrum: both spectra exhibit similar intensities of absorption at the same wave numbers.

Purity (1) Heavy metals <1.07>—Take 2.0 g of Colestimide in a porcelain or platinum crucible, and carbonize by weakly heating. After cooling, add 10 mL of a solution of magnesium nitrate hexahydrate in ethanol (95) (1 in 10) and 5 mL of hydrogen peroxide (30), and ignite the ethanol. After cooling, add 1 mL of sulfuric acid, then, proceed according to Method 4, and perform the test. Prepare the control solution as follows: To 10 mL of a solution of magnesium nitrate hexahydrate in ethanol (95) (1 in 10) add 5 mL of hydrogen peroxide (30), and ignite the ethanol. After cooling, add 1 mL of sulfuric acid, then, proceed in the same manner as for the test solution, and add 2.0 mL of Standard Lead Solution and water to make 50 mL (not more than 10 ppm).

(2) Related substances—To exactly 0.50 g of Colestimide add exactly 20 mL of water, shake for 1 hour, centrifuge, and use the supernatant liquid as the sample solution. Determine the absorbance of the sample solution at 210 nm as directed under Ultraviolet-visible Spectrophotometry <2.24>: the absorbance is not more than 0.50.

Loss on drying <2.41> Not more than 10.0% (1 g, in vacuum, 105°C, 4 hours).

Residue on ignition <2.44> Not more than 0.1% (1 g).

Degree of swelling Weigh accurately about 1 g of Colestimide, put in a 25-mL glass stoppered measuring cylinder (about 11 mm in inside diameter), add 23 mL of water, shake for 2 minutes, and add water to make 25 mL. After standing for 2 hours, measure the volume of the resin layer, and determine the volume per g, calculated on the dried basis: the volume is 12 – 18 mL/g.

Assay (1) Chlorine—Weigh accurately about 0.2 g of Colestimide, add 50 mL of water, and shake. Add 1 mL of nitric acid and 25 mg of potassium nitrate, shake, and titrate <2.50> with 0.1 mol/L silver nitrate VS (potentiometric titration). Perform a blank determination in the same manner, and make any necessary correction.

Each mL of 0.1 mol/L silver nitrate VS
= 3.545 mg of Cl

(2) Exchange capacity—Weigh accurately about 0.45 g of sodium cholate hydrate (separately determine the water), dissolve in water to make exactly 100 mL, and use this solution as the sodium cholate standard stock solution. Separately, weigh accurately about 30 mg of Colestimide, add exactly 30 mL of the sodium cholate standard stock solution, shake for 1 hour, and centrifuge or filter through a membrane filter with a pore size not exceeding 0.8 μ m. Pipet 5 mL of the supernatant liquid or the filtrate, add exactly 5 mL of the internal standard solution, and use this solution as the sample solution. Separately, pipet 5 mL of the sodium cholate standard stock solution, add exactly 5 mL of the internal standard solution, and use this solution as the standard solution. Perform the test with 10 μ L each of the sample solution and standard solution as directed under Liquid Chromatography <2.01> according to the following conditions, and calculate the ratios, Q_T and Q_S , of the peak area of cholic acid to that of the internal standard.

Exchanged amount (g) of cholic acid per g of Colestimide, calculated on the dried basis

$$= M_S/M_T \times (Q_S - Q_T)/Q_S \times 3/10 \times 0.947$$

M_S : Amount (mg) of sodium cholate hydrate taken, calcu-

lated on the anhydrous basis

M_T : Amount (mg) of Colestimide taken, calculated on the dried basis

Internal standard solution—A solution of butyl parahydroxybenzoate in acetonitrile (1 in 80,000).

Operating conditions—

Detector: An ultraviolet absorption photometer (wavelength: 220 nm).

Column: A stainless steel column 4.6 mm in inside diameter and 25 cm in length, packed with octadecylsilanized silica gel for liquid chromatography (5 μ m in particle diameter).

Column temperature: A constant temperature of about 30°C.

Mobile phase: A mixture of diluted phosphoric acid (1 in 1000) and acetonitrile (1:1).

Flow rate: Adjust so that the retention time of cholic acid is about 7 minutes.

System suitability—

System performance: When the procedure is run with 10 μ L of the standard solution under the above operating conditions, cholic acid and the internal standard are eluted in this order with the resolution between these peaks being not less than 7.

System repeatability: When the test is repeated 6 times with 10 μ L of the standard solution under the above operating conditions, the relative standard deviation of the ratio of the peak area of cholic acid to that of the internal standard is not more than 1.0%.

Containers and storage Containers—Tight containers.

Colestimide Granules

コレステミド顆粒

Colestimide Granules contain not less than 87.0% and not more than 113.0% of the labeled amount of colestimide.

Method of preparation Prepare as directed under Granules, with Colestimide.

Identification Determine the infrared absorption spectrum of powdered Colestimide Granules as directed in the potassium chloride disk method under Infrared Spectrophotometry <2.25>: it exhibits absorption at the wave numbers of about 1587 cm^{-1} , 1528 cm^{-1} and 1262 cm^{-1} .

Uniformity of dosage units <6.02> Colestimide Granules in single-dose packages meet the requirement of the Mass variation test.

Disintegration <6.09> Carry out the test for 10 minutes with 0.09 – 0.11 g of Colestimide Granules in six glass tubes of the apparatus: it meets the requirement.

Assay Weigh accurately about 4.5 g of sodium cholate hydrate (separately determine the water), dissolve in water to make exactly 1000 mL, and use this solution as the sodium cholate standard stock solution. Take out the contents of not less than 20 single-dose packages of Colestimide Granules, weigh accurately an amount of the contents, equivalent to about 0.2 g of colestimide, add exactly 200 mL of the sodium cholate standard stock solution, shake for 1 hour, and centrifuge. Pipet 5 mL of the supernatant liquid, add exactly 5 mL of the internal standard solution, and use this solution as the sample solution. Then, proceed as directed in the Assay (2) under Colestimide.

Amount (mg) of colestimide
 $= M_S \times (Q_S - Q_T)/Q_S \times 1/5 \times 1/2.2 \times 0.947$

M_S : Amount (mg) of sodium cholate hydrate taken, calculated on the anhydrous basis

2.2: Quantity (g) of the cholic acid exchange per mg of colestimide

Internal standard solution—A solution of butyl parahydroxybenzoate in acetonitrile (1 in 80,000).

Containers and storage Containers—Tight containers.

Colestimide Tablets

コレステミド錠

Colestimide Tablets contain not less than 87.0% and not more than 113.0% of the labeled amount of colestimide.

Method of preparation Prepare as directed under Tablets, with Colestimide.

Identification Powder Colestimide Tablets. Determine the infrared absorption spectrum of a portion of the powder as directed in the potassium chloride disk method under Infrared Spectrophotometry <2.25>: it exhibits absorption at the wave numbers of about 1587 cm^{-1} , 1528 cm^{-1} , 1262 cm^{-1} , 1102 cm^{-1} and 1035 cm^{-1} .

Uniformity of dosage units <6.02> It meets the requirement of the Mass variation test.

Disintegration <6.09> When carry out the test for 10 minutes, it meets the requirement.

Assay Weigh accurately about 0.45 g of sodium cholate hydrate (separately determine the water), dissolve in water to make exactly 100 mL, and use this solution as the sodium cholate standard stock solution. Separately, weigh accurately the mass of not less than 20 Colestimide Tablets, and powder. Weigh accurately a portion of the powder, equivalent to about 30 mg of colestimide, add exactly 30 mL of the sodium cholate standard stock solution, shake for 1 hour, and centrifuge. Pipet 5 mL of the supernatant liquid, add exactly 5 mL of the internal standard solution, and use this solution as the sample solution. Separately, pipet 5 mL of the sodium cholate standard stock solution, add exactly 5 mL of the internal standard solution, and use this solution as the standard solution. Perform the test with 10 μ L each of the sample solution and standard solution as directed under Liquid Chromatography <2.01> according to the following conditions, and calculate the ratios, Q_T and Q_S , of the peak area of cholic acid to that of the internal standard.

Amount (mg) of colestimide
 $= M_S \times (Q_S - Q_T)/Q_S \times 3/10 \times 1/2.2 \times 0.947$

M_S : Amount (mg) of sodium cholate hydrate taken, calculated on the anhydrous basis

2.2: Exchanged amount (g) of cholic acid per g of colestimide, calculated on the dried basis

Internal standard solution—A solution of butyl parahydroxybenzoate in acetonitrile (1 in 80,000).

Operating conditions—

Detector: An ultraviolet absorption photometer (wavelength: 220 nm).

Column: A stainless steel column 4.6 mm in inside diameter and 25 cm in length, packed with octadecylsilanized silica

gel for liquid chromatography (5 μm in particle diameter).

Column temperature: A constant temperature of about 30°C.

Mobile phase: A mixture of diluted phosphoric acid (1 in 1000) and acetonitrile (1:1).

Flow rate: Adjust so that the retention time of cholic acid is about 7 minutes.

System suitability—

System performance: When the procedure is run with 10 μL of the standard solution under the above operating conditions, cholic acid and the internal standard are eluted in this order with the resolution between these peaks being not less than 7.

System repeatability: When the test is repeated 6 times with 10 μL of the standard solution under the above operating conditions, the relative standard deviation of the ratio of the peak area of cholic acid to that of the internal standard is not more than 1.0%.

Containers and storage Containers—Tight containers.

Colistin Sodium Methanesulfonate

コリスチンメタンスルホン酸ナトリウム

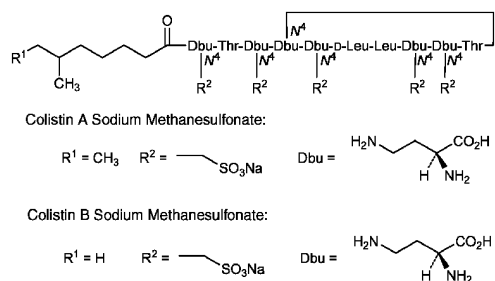

Colistin A Sodium Methanesulfonate

$\text{C}_{58}\text{H}_{105}\text{N}_{16}\text{Na}_5\text{O}_{28}\text{S}_5$: 1749.82

Colistin B Sodium Methanesulfonate

$\text{C}_{57}\text{H}_{103}\text{N}_{16}\text{Na}_5\text{O}_{28}\text{S}_5$: 1735.79

[8068-28-8, Colistin Sodium Methanesulfonate]

Colistin Sodium Methanesulfonate is the sodium salt of colistin derivatives.

It is a mixture of colistin A sodium methanesulfonate and colistin B sodium methanesulfonate.

It, when dried, contains not less than 11,500 Units and not more than 15,500 Units per mg. The unit of Colistin Sodium Methanesulfonate is expressed as mass of colistin A ($R = 6$ -methyloctanic acid, $R' = \text{H}$; $\text{C}_{53}\text{H}_{100}\text{N}_{16}\text{O}_{13}$: 1169.46).

Description Colistin Sodium Methanesulfonate occurs as a white to light yellow-white powder.

It is freely soluble in water, and practically insoluble in ethanol (95).

Identification (1) Dissolve 20 mg of Colistin Sodium Methanesulfonate in 2 mL of water, add 0.5 mL of sodium hydroxide TS, and add 5 drops of copper (II) sulfate TS while shaking: a blue-purple color develops.

(2) Dissolve 40 mg of Colistin Sodium Methanesulfonate in 1 mL of 1 mol/L hydrochloric acid TS, and add 0.5 mL of dilute iodine TS: the color of iodine disappears.

(3) Determine the infrared absorption spectrum of Colistin Sodium Methanesulfonate, previously dried, as directed in the potassium bromide disk method under Infrared Spectrophotometry <2.25>, and compare the spectrum with

the Reference Spectrum or the spectrum of dried Colistin Sodium Methanesulfonate RS: both spectra exhibit similar intensities of absorption at the same wave numbers.

(4) Colistin Sodium Methanesulfonate responds to Qualitative Tests <1.09> (1) for sodium salt.

pH <2.54> Dissolve 0.1 g of Colistin Sodium Methanesulfonate in 10 mL of water, and allow to stand for 30 minutes: the pH of the solution is between 6.5 and 8.5.

Purity (1) Clarity and color of solution—Dissolve 0.16 g of Colistin Sodium Methanesulfonate in 10 mL of water: the solution is clear and colorless.

(2) Heavy metals <1.07>—Proceed with 1.0 g of Colistin Sodium Methanesulfonate according to Method 4, and perform the test. Prepare the control solution with 3.0 mL of Standard Lead Solution (not more than 30 ppm).

(3) Arsenic <1.11>—Prepare the test solution with 1.0 g of Colistin Sodium Methanesulfonate according to Method 4, and perform the test (not more than 2 ppm).

(4) Free colistin—Dissolve 80 mg of Colistin Sodium Methanesulfonate in 3 mL of water, add 0.05 mL of a solution of silicotungstic acid 26-water (1 in 10), and immediately compare the solution with the reference suspension described under Test Methods for Plastic Containers <7.02>: the turbidity is not greater than that of the reference suspension (not more than 0.25%).

Loss on drying <2.41> Not more than 3.0% (0.1 g, reduced pressure, 60°C, 3 hours).

Assay Perform the test according to the Cylinder-plate method as directed under Microbial Assay for Antibiotics <4.02> according to the following conditions.

(i) Test organism—*Escherichia coli* NIHJ

(ii) Culture medium—To 10.0 g of peptone, 30.0 g of sodium chloride, 3.0 g of meat extract and 20.0 g of agar add 1000 mL of water, then add a suitable amount of sodium hydroxide TS so that the pH of the medium is being 6.5 to 6.6 after sterilization, sterile, and use this as the seeded agar medium and the agar medium for base layer.

(iii) Standard solutions—Weigh accurately an amount of Colistin Sodium Methanesulfonate RS, previously dried, dissolve in phosphate buffer solution (pH 6.0) to make a solution containing 100,000 Units per mL, and use this solution as the standard stock solution. Keep the standard stock solution at 10°C or below and use within 7 days. Take exactly a suitable amount of the standard stock solution before use, and add phosphate buffer solution (pH 6.0) to make solutions so that each mL contains 10,000 Units and 2500 Units, and use these solutions as the high concentration standard solution and the low concentration standard solution, respectively.

(iv) Sample solutions—Weigh accurately an amount of Colistin Sodium Methanesulfonate, previously dried, dissolve in phosphate buffer solution (pH 6.0) to make a solution containing about 100,000 Units per mL, and use this solution as the sample stock solution. Take exactly a suitable amount of the sample stock solution, add phosphate buffer solution (pH 6.0) to make solutions so that each mL contains 10,000 Units and 2500 Units, and use these solutions as the high concentration sample solution and the low concentration sample solution, respectively.

Containers and storage Containers—Tight containers.

Colistin Sulfate

コリスチン硫酸塩

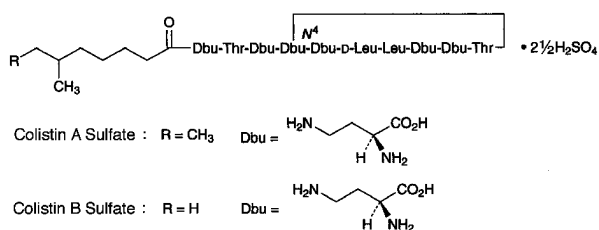

Colistin A Sulfate C₅₃H₁₀₀N₁₆O₁₃·2½H₂SO₄: 1414.66

Colistin B Sulfate C₅₂H₉₈N₁₆O₁₃·2½H₂SO₄: 1400.63

[1264-72-8]

Colistin Sulfate is the sulfate of a mixture of peptide substances having antibacterial activity produced by the growth of *Bacillus polymyxa* var. *colistinus*.

It, when dried, contains not less than 16,000 units per mg. The potency of Colistin Sulfate is expressed as unit calculated from the amount of colistin A (C₅₃H₁₀₀N₁₆O₁₃: 1169.46). One unit of Colistin Sulfate is equivalent to 0.04 μg of colistin A (C₅₃H₁₀₀N₁₆O₁₃).

Description Colistin Sulfate occurs as a white to light yellow-white powder.

It is freely soluble in water, and practically insoluble in ethanol (99.5).

It is hygroscopic.

Identification (1) Dissolve 20 mg of Colistin Sulfate in 2 mL of water, add 0.5 mL of sodium hydroxide TS, then add 5 drops of copper (II) sulfate TS while shaking: a purple color develops.

(2) Dissolve 50 mg of Colistin Sulfate in 10 mL of diluted hydrochloric acid (1 in 2). Transfer 1 mL of this solution in a tube for hydrolysis, seal, and heat at 135°C for 5 hours. After cooling, open the tube, and evaporate the content to dryness until the odor of hydrochloric acid is no more perceptible. Dissolve the residue in 0.5 mL of water, and use this solution as the sample solution. Separately, dissolve 20 mg each of L-leucine, L-threonine, phenylalanine and L-serine in 10 mL of water, and use these solutions as the standard solution (1), (2), (3) and (4). Perform the test with these solutions as directed under Thin-layer Chromatography <2.03>. Spot 1 μL each of the sample solution and standard solution (1), (2), (3) and (4) on a plate of cellulose for thin-layer chromatography. Develop the plate with a mixture of 1-butanol, acetic acid (100), water, pyridine and ethanol (99.5) (60:15:10:6:5) to a distance of about 10 cm, and dry the plate at 105°C for 10 minutes. Spray evenly ninhydrin TS on the plate, and heat at 110°C for 5 minutes: three principal spots are obtained from the sample solution, the R_f values of two spots of them are the same with those of the corresponding spots obtained from the standard solution (1) and the standard solution (2), and the R_f value of the rest principal spot is about 0.1. No spot is observed at the position corresponding to the spots from the standard solution (3) and the standard solution (4).

(3) A solution of Colistin Sulfate (1 in 20) responds to Qualitative Tests <1.09> (1) for sulfate.

Optical rotation <2.49> [α]_D²⁰: -63 - -73° (1.25 g, after drying, water, 25 mL, 100 mm).

pH <2.54> The pH of a solution obtained by dissolving

0.10 g of Colistin Sulfate in 10 mL of water is between 4.0 and 6.0.

Purity (1) Sulfuric acid—Weigh accurately about 0.25 g of previously dried Colistin Sulfate, dissolve in a suitable amount of water, adjust the pH to 11 with ammonia solution (28), and add water to make 100 mL. To this solution add exactly 10 mL of 0.1 mol/L barium chloride VS and 50 mL of ethanol (99.5), and titrate with <2.50> 0.1 mol/L disodium dihydrogen ethylenediamine tetraacetate VS until the blue-purple color of the solution disappears (indicator: 0.5 mg of phthalein purple): the amount of sulfuric acid (SO₄) is 16.0 to 18.0%.

Each mL of 0.1 mol/L barium chloride VS
= 9.606 mg of SO₄

(2) Related substances—Dissolve 50 mg of Colistin Sulfate in 10 mL of water, and use this solution as the sample solution. Pipet 1 mL of the sample solution, add water to make exactly 50 mL, and use this solution as the standard solution. Perform the test with these solutions as directed under Thin-layer Chromatography <2.03>. Spot 1 μL each of the sample solution and standard solution on a plate of silica gel for thin-layer chromatography. Develop the plate with a mixture of pyridine, 1-butanol, water and acetic acid (100) (6:5:4:1) to a distance of about 10 cm, and dry the plate at 100°C for 30 minutes. Spray evenly ninhydrin-butanol TS on the plate, and heat at 100°C for about 20 minutes: the spot other than the principal spot obtained from the sample solution is not more intense than the spot from the standard solution.

Loss on drying <2.41> Not more than 6.0% (1 g, in vacuum, 60°C, 3 hours).

Residue on ignition <2.44> Not more than 1.0% (1 g).

Assay Perform the test according to the Cylinder-plate method as directed under Microbial Assay for Antibiotics <4.02> according to the following conditions.

(i) Test organism—*Escherichia coli* NIHJ

(ii) Culture medium—Dissolve 10.0 g of peptone, 30.0 g of sodium chloride, 3.0 g of meat extract and 15.0 g of agar in 1000 mL of water, adjust the pH with sodium hydroxide TS so that the solution will be 6.5 to 6.6 after sterilization, and use as the agar media for seed layer and for base layer.

(iii) Standard solutions—Weigh accurately an amount of Colistin Sulfate RS, previously dried, equivalent to about 1,000,000 units, dissolve in phosphate buffer solution (pH 6.0) to make exactly 10 mL, and use this solution as the standard stock solution. Keep the standard stock solution at not exceeding 10°C, and use within 7 days. Take exactly a suitable amount of the standard stock solution before use, add phosphate buffer solution (pH 6.0) to make solutions so that each mL contains 10,000 units and 2500 units, and use these solutions as the high concentration standard solution and the low concentration standard solution, respectively.

(iv) Sample solutions—Weigh accurately an amount of Colistin Sulfate, previously dried, equivalent to about 1,000,000 units, and dissolve in phosphate buffer solution (pH 6.0) to make exactly 10 mL. Take exactly a suitable amount of this solution, add phosphate buffer solution (pH 6.0) to make solutions so that each mL contains 10,000 units and 2500 units, and use these solutions as the high concentration sample solution and the low concentration sample solution, respectively.

Containers and storage Containers—Tight containers.

Copovidone

コポビドン

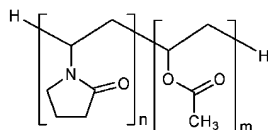

$(C_6H_9NO)_n(C_4H_6O_2)_m$
Poly[(2-oxopyrrolidin-1-yl)ethylene-co-(1-acetoxyethylene)]
[25086-89-9]

This monograph is harmonized with the European Pharmacopoeia and the U.S. Pharmacopoeia.

The corresponding part of the attributes/provisions which are agreed as non-harmonized within the scope of the harmonization is marked with symbols (◆ ◆), and the corresponding parts which are agreed as the JP local requirement other than the scope of the harmonization are marked with symbols (◇ ◇).

Information on the harmonization with the European Pharmacopoeia and the U.S. Pharmacopoeia is available on the website of the Pharmaceuticals and Medical Devices Agency.

Copovidone is a copolymer of 1-vinyl-2-pyrrolidone and vinyl acetate at the ratio by mass of 3:2.

It contains not less than 35.3% and not more than 42.0% of vinyl acetate ($C_4H_6O_2$: 86.09), and not less than 7.0% and not more than 8.0% of nitrogen (N: 14.01), calculated on the dried basis.

The nominal K-value is shown on the label.

◆**Description** Copovidone occurs as a white to yellowish white powder. It is odorless or has a faint, characteristic odor.

It is very soluble in methanol and in ethanol (95), and freely soluble in water.

It is hygroscopic.◆

Identification Determine the infrared absorption spectrum of Copovidone, previously dried, as directed in the potassium bromide disk method under Infrared Spectrophotometry <2.25>, and compare the spectrum with the Reference Spectrum: both spectra exhibit similar intensities of absorption at the same wave numbers.

pH <2.54> Dissolve 1.0 g of Copovidone in 10 mL of water: the pH of this solution is between 3.0 and 7.0.

Purity (1) Clarity and color of solution—Dissolve 1.0 g of Copovidone in 10 mL of water: the solution is clear or slightly opalescent and colorless to pale yellow, or pale red.

◇(2) Heavy metals <1.07>—Ignite 2.0 g of Copovidone as directed under Residue on Ignition Test <2.44>, add 2 mL of hydrochloric acid to the residue, then proceed according to Method 2, and perform the test. Prepare the control solution with 2.0 mL of Standard Lead Solution (not more than 10 ppm).◇

(3) Aldehydes—Weigh accurately about 1 g of Copovidone, dissolve in 0.05 mol/L pyrophosphate buffer solution (pH 9.0) to make exactly 100 mL. Stopper, heat at 60°C for 60 minutes, allow to cool to room temperature, and use this solution as the sample solution. Separately, dissolve 0.140 g of acetaldehyde ammonia trimer trihydrate in water to make exactly 200 mL. Pipet 1 mL of this solution, add 0.05 mol/L pyrophosphate buffer solution (pH 9.0) to make exactly 100

mL, and use this solution as the standard solution. Measure exactly 0.5 mL each of the sample solution, standard solution and water, transfer to separate 1-cm cells, add 2.5 mL of 0.05 mol/L pyrophosphate buffer solution (pH 9.0) and 0.2 mL of β -nicotinamide adenine dinucleotide TS to each of these cells, mix and stopper tightly. Allow to stand for 2 to 3 minutes at $22 \pm 2^\circ\text{C}$, and perform the test with these solutions as directed under Ultraviolet-visible Spectrophotometry <2.24> using water as the control solution. Determine the absorbances, A_{T1} , A_{S1} and A_{B1} , of the subsequent solutions of the sample solution, the standard solution and water (blank) at 340 nm. Then, add 0.05 mL of aldehyde dehydrogenase TS to each of the cells, stir, and stopper tightly. Allow to stand at $22 \pm 2^\circ\text{C}$ for 5 minutes. Determine the absorbances, A_{T2} , A_{S2} and A_{B2} , of these solutions in the same manner as above: the content of aldehyde is not more than 500 ppm.

$$\begin{aligned} \text{Content (ppm) of aldehydes [as acetaldehyde (CH}_3\text{CHO)]} \\ = C/M \times \{(A_{T2} - A_{T1}) - (A_{B2} - A_{B1})\} / \{(A_{S2} - A_{S1}) \\ - (A_{B2} - A_{B1})\} \times 100,000 \end{aligned}$$

M : Amount (g) of Copovidone taken, calculated on the dried basis

C : Concentration (mg/mL) of acetaldehyde in the standard solution, using 0.72 as conversion factor for acetaldehyde ammonia trimer trihydrate to acetaldehyde

(4) 1-Vinyl-2-pyrrolidone and free vinyl acetate—Store the sample solution and the standard solution at 5°C or below, and use within 8 hours. Weigh accurately about 0.25 g of Copovidone, dissolve in a mixture of water and acetonitrile (23:2) to make exactly 10 mL, and use this solution as the sample solution. Separately, dissolve 50 mg each of 1-vinyl-2-pyrrolidone and vinyl acetate in methanol to make exactly 100 mL. Pipet 1 mL of this solution and add methanol to make exactly 100 mL. Pipet 5 mL of this solution, add a mixture of water and acetonitrile (23:2) to make exactly 100 mL, and use this solution as the standard solution. Perform the test with exactly 20 μL each of the sample solution and standard solution as directed under Liquid Chromatography <2.07> according to the following conditions, determine the peak areas, A_{Ta} , A_{Tb} , A_{Sa} and A_{Sb} , of 1-vinyl-2-pyrrolidone and free vinyl acetate in each solution, and calculate the content of 1-vinyl-2-pyrrolidone and vinyl acetate by the following equations: they are not more than 10 ppm.

$$\begin{aligned} \text{Content (ppm) of 1-vinyl-2-pyrrolidone} \\ = A_{Ta}/A_{Sa} \times C_{Sa}/C_T \times 1000 \end{aligned}$$

$$\begin{aligned} \text{Content (ppm) of free vinyl acetate} \\ = A_{Tb}/A_{Sb} \times C_{Sb}/C_T \times 1000 \end{aligned}$$

C_{Sa} : Concentration ($\mu\text{g/mL}$) of 1-vinyl-2-pyrrolidone in the standard solution

C_{Sb} : Concentration ($\mu\text{g/mL}$) of vinyl acetate in the standard solution

C_T : Concentration (mg/mL) of Copovidone in the sample solution, calculated on the dried basis

Operating conditions—

Detector: An ultraviolet spectrophotometer (wavelength: 235 nm for 1-vinyl-2-pyrrolidone, 205 nm for vinyl acetate).

Column: Two stainless steel columns, one is 4 mm in inside diameter and 33 mm in length and the other is 4 mm in inside diameter and 250 mm in length, packed with octadecylsilanized silica gel for liquid chromatography (5 μm in particle diameter), and use them as the pre-column and the separation column, respectively.

Column temperature: A constant temperature of about

40°C.

Mobile phase: A mixture of water and acetonitrile (23:2).

Flow rate: 1.0 mL per minute (Retention times of 1-vinyl-2-pyrrolidone and vinyl acetate are about 17 and about 22 minutes, respectively).

Time span of measurement: For 40 minutes.

Washing of column: After each test with the sample solution, elute and wash away remaining sample by passing the mobile phase through the separation column or the pre-column backwards at the flow rate mentioned above for about 30 minutes.

System suitability—

System performance: When the procedure is run with 20 μ L of the standard solution under the above operating conditions (wavelength: 205 nm), 1-vinyl-2-pyrrolidone and vinyl acetate are eluted in this order with the resolution between these peaks being not less than 2.0.

System repeatability: When the test is repeated 6 times with 20 μ L of the standard solution under the above operating conditions, the relative standard deviations of the peak areas of 1-vinyl-2-pyrrolidone and vinyl acetate are not more than 2.0%, respectively.

(5) Peroxides—Weigh exactly an amount of Copovidone, equivalent to 4.0 g calculated on the dried basis, dissolve in water to make exactly 100 mL, and use this solution as the sample solution. To 25 mL of the sample solution add 2 mL of titanium (III) chloride-sulfuric acid TS, and mix. Allow to stand for 30 minutes, and perform the test with this solution as directed under Ultraviolet-visible Spectrophotometry <2.24>, using a solution prepared by adding 2 mL of diluted sulfuric acid (13 in 100) to 25 mL of the sample solution as a blank: the absorbance of the sample solution at 405 nm is not more than 0.35 (not more than 400 ppm, as hydrogen peroxide).

(6) Hydrazine—Weigh exactly an amount of Copovidone equivalent to 2.5 g calculated on the dried basis, transfer to a 50-mL centrifuge tube, add 25 mL of water, and stir to dissolve. Add 500 μ L of a solution of salicylaldehyde in methanol (1 in 20), stir and warm at 60°C for 15 minutes in a water bath. Allow to cool, add 2.0 mL of toluene, stopper tightly, shake vigorously for 2 minutes, centrifuge, and use the upper layer of the mixture as the sample solution. Separately, dissolve 90 mg of salicylaldazine in toluene to make exactly 100 mL. Pipet 1 mL of this solution, add toluene to make exactly 100 mL, and use this solution as the standard solution. Perform the test with these solutions as directed under Thin-layer Chromatography <2.03>. Spot 10 μ L each of the sample solution and standard solution on a plate of dimethylsilanized silica gel with fluorescent indicator for thin-layer chromatography. Develop the plate with a mixture of methanol and water (2:1) to a distance of about three-fourths of the length of the plate, and air-dry the plate. Examine under ultraviolet light (main wavelength: 365 nm): the fluorescence of the spot obtained from the sample solution corresponding to the spot having a *R_f* value of about 0.3 from the standard solution is not more intense than that of the spot from the standard solution (not more than 1 ppm).

(7) 2-Pyrrolidone—Weigh accurately about 1 g of Copovidone, add 5 mL of methanol for liquid chromatography, and sonicate to dissolve. Add water to make exactly 100 mL, and use this solution as the sample solution. Separately, dissolve 0.150 g of 2-pyrrolidone in a mixture of water and methanol for liquid chromatography (19:1) to make exactly 100 mL. Pipet 3 mL of this solution, add a mixture of water and methanol for liquid chromatography (19:1) to make exactly 100 mL, and use this solution as the standard solution. Perform the test with exactly 20 μ L each of the sample solu-

tion and standard solution as directed under Liquid Chromatography <2.01> according to the following conditions, and determine the peak areas, *A_T* and *A_S*, of 2-pyrrolidone in each solution. Calculate the content of 2-pyrrolidone by the following equation: not more than 0.5%.

$$\text{Content (\% of 2-pyrrolidone)} = A_T/A_S \times C_S/C_T \times 100$$

C_S: Concentration (mg/mL) of 2-pyrrolidone in the standard solution

C_T: Concentration (mg/mL) of Copovidone in the sample solution, calculated on the dried basis

Operating conditions—

Detector: An ultraviolet absorption photometer (wavelength: 205 nm).

Column: Two stainless steel columns, one is 4.0 mm in inside diameter and 10 mm in length and the other is 4.6 mm in inside diameter and 150 mm in length, packed with octadecylsilanized silica gel for liquid chromatography (5 μ m in particle diameter), and use them as the pre-column and the separation column, respectively.

Column temperature: A constant temperature of about 40°C.

Mobile phase: A mixture of water and methanol for liquid chromatography (19:1).

Flow rate: 0.8 mL per minute (retention time of 2-pyrrolidone is about 7 minutes).

Time span of measurement: For 30 minutes.

Washing of column: After each test with the sample solution, elute and wash away remaining sample by passing the mobile phase through the separation column or the pre-column backwards at the flow rate mentioned above for about 30 minutes.

System suitability—

System performance: When the procedure is run with 20 μ L of the standard solution under the above operating conditions, the symmetry factor of the peak of 2-pyrrolidone is not more than 1.5.

System repeatability: When the test is repeated 6 times with 20 μ L of the standard solution under the above operating conditions, the relative standard deviation of the peak area of 2-pyrrolidone is not more than 2.0%.

Loss on drying <2.41> Not more than 5.0% (0.5 g, 105°C, 3 hours).

Residue on ignition <2.44> Not more than 0.1% (1 g).

K-value Weigh accurately an amount of Copovidone, equivalent to 1.00 g, calculated on the dried basis, dissolve in water to make exactly 100 mL, allow to stand for 60 minutes, and use this solution as the sample solution. Perform the test with the sample solution and with water at 25°C as directed in Method 1 under Viscosity Determination <2.53>, and calculate the K-value by the following formula: the K-value of Copovidone is not less than 90.0% and not more than 110.0% of the nominal K-value.

$$K = \frac{1.5 \log v_{rel.} - 1}{0.15 + 0.003c} +$$

$$\frac{\sqrt{300c \log v_{rel.} + (c + 1.5c \log v_{rel.})^2}}{0.15c + 0.003c^2}$$

c: Mass (g) of Copovidone in 100 mL of the solution, calculated on the dried basis

v_{rel.}: Kinematic viscosity of the sample solution relative to that of water

Assay (1) Vinyl acetate—Weigh accurately about 2 g of

Copovidone, add exactly 25 mL of 0.5 mol/L potassium hydroxide-ethanol VS and a few glass beads, heat under reflux for 30 min. Titrate immediately with 0.5 mol/L hydrochloric acid VS (indicator: 1 mL of phenolphthalein TS). Perform a blank determination in the same manner, and make any necessary correction.

Amount (%) of vinyl acetate

$$= 0.1 \times \frac{86.09}{56.11} \times \frac{28.05 (n_2 - n_1)}{M}$$

M: Amount (g) of Copovidone taken, calculated on the dried basis

*n*₁: Volume (mL) of 0.5 mol/L hydrochloric acid VS consumed in the test

*n*₂: Volume (mL) of 0.5 mol/L hydrochloric acid VS consumed in the blank test

(2) Nitrogen—Weigh accurately about 0.1 g of Copovidone, and place in a Kjeldahl flask. Add 5 g of a decomposition accelerator (a powdered mixture of 33 g of potassium sulfate, 1 g of copper (II) sulfate pentahydrate and 1 g of titanium (IV) oxide), and wash down any adhering sample from the neck of the flask with a small amount of water. Add 7 mL of sulfuric acid allowing to flow down the inside wall of the flask. Heat the flask gradually until the solution has a clear, yellow-green color, and the inside wall of the flask is free from a carbonized material, and then heat for further 45 minutes. After cooling, add cautiously 20 mL of water, and connect the flask to the distillation apparatus previously washed by passing steam through it. To the absorption flask add 30 mL of a solution of boric acid (1 in 25), 3 drops of bromocresol green-methyl red TS and sufficient water to immerse the lower end of the condenser tube. Add 30 mL of a solution of sodium hydroxide (2 in 5) through the funnel, rinse cautiously the funnel with 10 mL of water, immediately close the clamp attached to the rubber tube, then start the distillation with steam to obtain 80 to 100 mL of the distillate. Remove the absorption flask from the lower end of the condenser tube, rinsing the end part with a small quantity of water, and titrate <2.50> the distillate with 0.025 mol/L sulfuric acid VS until the color of the solution changes from green through pale grayish blue to pale grayish red-purple. Perform a blank determination in the same manner, and make any necessary correction.

Each mL of 0.025 mol/L sulfuric acid VS = 0.700 mg of N

◆Containers and storage Containers—Tight containers.◆

Cortisone Acetate

コルチゾン酢酸エステル

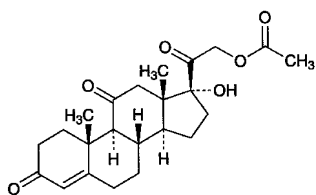

C₂₃H₃₀O₆: 402.48

17,21-Dihydroxypregn-4-ene-3,11,20-trione 21-acetate
[50-04-4]

Cortisone Acetate, when dried, contains not less than 97.0% and not more than 102.0% of cortisone acetate (C₂₃H₃₀O₆).

Description Cortisone Acetate occurs as white, crystals or crystalline powder.

It is sparingly soluble in methanol, slightly soluble in ethanol (99.5), and practically insoluble in water.

Melting point: about 240°C (with decomposition).

It shows crystal polymorphism.

Identification (1) To 2 mg of Cortisone Acetate add 2 mL of sulfuric acid, and allow to stand for a while: a yellowish green color is produced, and it gradually changes to yellow-orange. Examine the solution under ultraviolet light: the solution shows a light green fluorescence. Add carefully 10 mL of water to this solution: the color of the solution is discharged, and the solution remains clear.

(2) Determine the absorption spectrum of a solution of Cortisone Acetate in methanol (1 in 50,000) as directed under Ultraviolet-visible Spectrophotometry <2.24>, and compare the spectrum with the Reference Spectrum or the spectrum of a solution of Cortisone Acetate RS prepared in the same manner as the sample solution: both spectra exhibit similar intensities of absorption at the same wavelengths.

(3) Determine the infrared absorption spectrum of Cortisone Acetate, previously dried, as directed in the potassium bromide disk method under Infrared Spectrophotometry <2.25>, and compare the spectrum with the Reference Spectrum or the spectrum of previously dried Cortisone Acetate RS: both spectra exhibit similar intensities of absorption at the same wave numbers. If any difference appears between the spectra, dissolve Cortisone Acetate and Cortisone Acetate RS in acetone, respectively, then evaporate the acetone to dryness, and repeat the test on the residues.

Optical rotation <2.49> [α]_D²⁰: +207 – +216° (after drying, 0.1 g, methanol, 10 mL, 100 mm).

Purity Related substances—Dissolve 25 mg of Cortisone Acetate in 10 mL of a mixture of acetonitrile, water and acetic acid (100) (70:30:1), and use this solution as the sample solution. Pipet 1 mL of the sample solution add the mixture of acetonitrile, water and acetic acid (100) (70:30:1) to make exactly 100 mL, and use this solution as the standard solution. Perform the test with exactly 15 μL each of the sample solution and standard solution as directed under Liquid Chromatography <2.01> according to the following conditions, and determine each peak area by the automatic integration method: each peak area other than cortisone acetate obtained from the sample solution is not larger than 1/2 times the peak area of cortisone acetate from the standard solution, and the total area of the peaks other than cortisone acetate is not larger than 1.5 times the peak area of cortisone acetate from the standard solution.

Operating conditions—

Detector: An ultraviolet absorption photometer (wavelength: 254 nm).

Column: A stainless steel column 4.6 mm in inside diameter and 15 cm in length, packed with octadecylsilanized silica gel for liquid chromatography (5 μm in particle diameter).

Column temperature: A constant temperature of about 25°C.

Mobile phase A: A mixture of water and acetonitrile (7:3).

Mobile phase B: A mixture of acetonitrile and water (7:3).

Flowing of mobile phase: Control the gradient by mixing the mobile phases A and B as directed in the following table.

Time after injection of sample (min)	Mobile phase A (vol%)	Mobile phase B (vol%)
0 - 5	90	10
5 - 25	90 → 10	10 → 90
25 - 30	10	90

Flow rate: About 1 mL per minute.

Time span of measurement: About 3 times as long as the retention time of cortisone acetate, beginning after the solvent peak.

System suitability—

Test for required detectability: To exactly 1 mL of the standard solution add a mixture of acetonitrile, water and acetic acid (100) (70:30:1) to make exactly 10 mL. Confirm that the peak area of cortisone acetate obtained with 15 μ L of this solution is equivalent to 8 to 12% of that with 15 μ L of the standard solution.

System performance: When the procedure is run with 15 μ L of the sample solution under the above operating conditions, the number of theoretical plates and the symmetry factor of the peak of cortisone acetate are not less than 10,000 and not more than 1.3, respectively.

System repeatability: When the test is repeated 3 times with 15 μ L of the standard solution under the above operating conditions, the relative standard deviation of the peak area of cortisone acetate is not more than 5.0%.

Loss on drying <2.41> Not more than 1.0% (0.5 g, 105°C, 3 hours).

Residue on ignition <2.44> Not more than 0.1% (0.5 g).

Assay Dissolve about 10 mg each of Cortisone Acetate and Cortisone Acetate RS, previously dried and accurately weighed, in 50 mL of methanol, add exactly 5 mL each of the internal standard solution, then add methanol to make 100 mL, and use these solutions as the sample solution and the standard solution. Perform the test with 10 μ L each of the sample solution and standard solution as directed under Liquid Chromatography <2.01> according to the following conditions, and calculate the ratios, Q_T and Q_S , of the peak area of cortisone acetate to that of the internal standard.

$$\begin{aligned} &\text{Amount (mg) of cortisone acetate (C}_{23}\text{H}_{30}\text{O}_6) \\ &= M_S \times Q_T/Q_S \end{aligned}$$

M_S : Amount (mg) of Cortisone Acetate RS taken

Internal standard solution—A solution of butyl parahydroxybenzoate in methanol (3 in 5000).

Operating conditions—

Detector: An ultraviolet absorption photometer (wavelength: 254 nm).

Column: A stainless steel column 4.6 mm in inside diameter and 30 cm in length, packed with octadecylsilanized silica gel for liquid chromatography (10 μ m in particle diameter).

Column temperature: A constant temperature of about 25°C.

Mobile phase: A mixture of water and acetonitrile (13:7).

Flow rate: Adjust so that the retention time of cortisone acetate is about 12 minutes.

System suitability—

System performance: When the procedure is run with 10 μ L of the standard solution under the above operating conditions, cortisone acetate and the internal standard are eluted in this order with the resolution between these peaks being not less than 4.

System repeatability: When the test is repeated 6 times

with 10 μ L of the standard solution under the above operating conditions, the relative standard deviation of the ratios of the peak area of cortisone acetate to that of the internal standard is not more than 1.0%.

Containers and storage Containers—Tight containers.

Absorptive Cream

吸水クリーム

Method of preparation

White Petrolatum	400 g
Cetanol	100 g
White Beeswax	50 g
Sorbitan Sesquioleate	50 g
Lauromacrogol	5 g
Ethyl Parahydroxybenzoate or Methyl Parahydroxybenzoate	1 g
Butyl Parahydroxybenzoate or Propyl Parahydroxybenzoate	1 g
Purified Water or Purified Water in Containers	a sufficient quantity
To make 1000 g	

Melt White Petrolatum, Cetanol, White Beeswax, Sorbitan Sesquioleate and Lauromacrogol by heating on a water bath, mix and maintain at about 75°C. Add Methyl Parahydroxybenzoate or Ethyl Parahydroxybenzoate and Propyl Parahydroxybenzoate or Butyl Parahydroxybenzoate to Purified Water or Purified Water in Containers, dissolve by warming at 80°C. Combine both solutions, mix to make emulsion, cool, and stir thoroughly until it congeals.

Description Absorptive Cream is white in color and is lustrous. It has a slightly characteristic odor.

Containers and storage Containers—Tight containers.

Hydrophilic Cream

親水クリーム

Method of preparation

White Petrolatum	250 g
Stearyl Alcohol	200 g
Propylene Glycol	120 g
Polyoxyethylene hydrogenated castor oil 60	40 g
Glycerin Monostearate	10 g
Methyl Parahydroxybenzoate	1 g
Propyl Parahydroxybenzoate	1 g
Purified Water or Purified Water in Containers	a sufficient quantity
To make 1000 g	

Melt White Petrolatum, Stearyl Alcohol, polyoxyethylene hydrogenated castor oil 60 and Glycerin Monostearate by heating on a water bath, stir, and keep temperature of the mixture at about 75°C. To Propylene Glycol add Methyl Parahydroxybenzoate and Propyl Parahydroxybenzoate, melt by warming if necessary, dissolve in Purified Water or Purified Water in Containers, and warm to about 75°C. Add this solution to the above mixture, stir to form emulsion, cool, and stir thoroughly until it congeals.

Description Hydrophilic Cream is white in color. It has a slight, characteristic odor.

Containers and storage Containers—Tight containers.

Cresol

クレゾール

C₇H₈O: 108.14

Cresol is a mixture of isomeric cresols.

Description Cresol is a clear, colorless or yellow to yellow-brown liquid. It has a phenol-like odor.

It is miscible with ethanol (95) and with diethyl ether.

It is sparingly soluble in water.

It dissolves in sodium hydroxide TS.

A saturated solution of Cresol is neutral to bromocresol purple TS.

It is a highly refractive liquid.

It becomes dark brown by light or on aging.

Identification To 5 mL of a saturated solution of Cresol add 1 to 2 drops of dilute iron (III) chloride TS: a blue-purple color develops.

Specific gravity <2.56> d_{20}^{20} : 1.032 – 1.041

Purity (1) Hydrocarbons—Dissolve 1.0 mL of Cresol in 60 mL of water: the solution shows no more turbidity than that produced in the following control solution.

Control solution: To 54 mL of water add 6.0 mL of 0.005 mol/L sulfuric acid VS and 1.0 mL of barium chloride TS, and after thorough shaking, allow to stand for 5 minutes.

(2) Sulfur compounds—Transfer 20 mL of Cresol in a 100-mL conical flask, place a piece of moistened lead (II) acetate paper on the mouth of the flask, and warm for 5 minutes on a water bath: the lead (II) acetate paper may develop a yellow color, but neither a brown nor a dark tint.

Distilling range <2.57> 196 – 206°C, not less than 90 vol%.

Containers and storage Containers—Tight containers.

Storage—Light-resistant.

Cresol Solution

クレゾール水

Cresol Solution contains not less than 1.25 vol% and not more than 1.60 vol% of cresol.

Method of preparation

Saponated Cresol Solution	30 mL
Water, Purified Water or Purified Water in Containers	a sufficient quantity
To make 1000 mL	

Prepare by mixing the above ingredients.

Description Cresol Solution is a clear or slightly turbid, yellow solution. It has the odor of cresol.

Identification Shake 0.5 mL of the oily layer obtained in the Assay with 30 mL of water, filter, and perform the following tests using this filtrate as the sample solution:

(1) To 5 mL of the sample solution add 1 to 2 drops of

iron (III) chloride TS: a blue-purple color develops.

(2) To 5 mL of the sample solution add 1 to 2 drops of bromine TS: a light yellow, flocculent precipitate is produced.

Assay Transfer 200 mL of Cresol Solution, exactly measured, to a 500-mL distilling flask. Add 40 g of sodium chloride and 3 mL of dilute sulfuric acid, and connect the distilling apparatus with the distilling flask, and distil into a cassia flask which contains 30 g of powdered sodium chloride and 3 mL of kerosene, exactly measured, until the distillate measures 90 mL. Draw off the water from the condenser, and continue the distillation until water vapor begins to come out of the tip of the condenser. Shake often the cassia flask in warm water to dissolve the sodium chloride, and allow to stand for 15 minutes. After cooling to 15°C, add a saturated solution of sodium chloride, and allow to stand for more than 3 hours with occasional shaking. Allow to stand for 1 to 2 minutes with gentle shaking to combine the separated oil drops with the oil layer. The difference between the number of mL of the oil layer measured and 3 mL represents the amount (mL) of cresol.

Containers and storage Containers—Tight containers.

Saponated Cresol Solution

クレゾール石ケン液

Saponated Cresol Solution contains not less than 42 vol% and not more than 52 vol% of cresol.

Method of preparation

Cresol	500 mL
Fixed Oil	300 mL
Potassium Hydroxide	a suitable quantity
Water, Purified Water or Purified Water in Containers	a sufficient quantity
To make 1000 mL	

Dissolve Potassium Hydroxide, in required quantity for saponification, in a sufficient quantity of Water, Purified Water or Purified Water in Containers, add this solution to fixed oil, previously warmed, add a sufficient quantity of Ethanol, if necessary, heat in a water bath by thorough stirring, and continue the saponification. After complete saponification, add Cresol, stir thoroughly until the mixture becomes clear, and add sufficient Water, Purified Water or Purified Water in Containers to make 1000 mL. A corresponding amount of Sodium Hydroxide may be used in place of Potassium Hydroxide.

Description Saponated Cresol Solution is a yellow-brown to red-brown, viscous liquid. It has the odor of cresol.

It is miscible with water, with ethanol (95) and with glycerin.

It is alkaline.

Identification Proceed as directed in the Identification under Cresol, using the distillate in the Purity (3).

Purity (1) Alkalinity—Mix well 0.50 mL of Saponated Cresol Solution with 10 mL of neutralized ethanol, add 2 to 3 drops of phenolphthalein TS and 0.10 mL of 1 mol/L hydrochloric acid VS: no red color develops.

(2) Unsaponified matter—To 1.0 mL of Saponated Cresol Solution add 5 mL of water, and shake: the solution is clear.

(3) Cresol fraction—Transfer 180 mL of Saponated Cresol Solution to a 2000-mL distilling flask, add 300 mL of water and 100 mL of dilute sulfuric acid, and distil with steam until the distillate becomes clear. Draw off the water from the condenser, and continue the distillation until water vapor begins to come out of the tip of the condenser. Cool the condenser again, and continue distillation for 5 minutes. Dissolve 20 g of sodium chloride per 100 mL of the distillate, allow to stand, and collect the separated clear oil layer. After adding about 15 g of powdered calcium chloride for drying in small portions with frequent shaking, allow to stand for 4 hours. Filter, and distil exactly 50 mL of the filtrate: the distillate is not less than 43 mL between 196°C and 206°C.

Assay Transfer 5 mL of Saponated Cresol Solution, exactly measured, to a 500-mL distilling flask, holding the pipet vertically for 15 minutes to draw off the solution into the flask. Add 200 mL of water, 40 g of sodium chloride and 3 mL of dilute sulfuric acid, connect the distilling apparatus with the distilling flask, and distil into a cassia flask which contains 30 g of powdered sodium chloride and exactly 3 mL of kerosene, until the distillate reaches 90 mL. Draw off the water from the condenser, and continue the distillation until water vapor begins to come out of the tip of the condenser. Allow the cassia flask to stand in warm water for 15 minutes to dissolve the sodium chloride with frequent shaking. Cool to 15°C, add a saturated solution of sodium chloride, and allow to stand for more than 3 hours with occasional shaking. Allow to stand for 1 to 2 minutes with gentle shaking, and combine the separated oil drops with the oil layer. The volume (mL) subtracted 3 (mL) from the oil layer measured represents the amount (mL) of cresol.

Containers and storage Containers—Tight containers.
Storage—Light-resistant.

Croconazole Hydrochloride

クロコナゾール塩酸塩

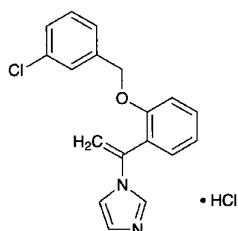

$C_{18}H_{15}ClN_2O \cdot HCl$: 347.24
1-[1-[2-(3-Chlorobenzoyloxy)phenyl]vinyl]-1H-imidazole
monohydrochloride
[77174-66-4]

Croconazole Hydrochloride, when dried, contains not less than 98.5% of croconazole hydrochloride ($C_{18}H_{15}ClN_2O \cdot HCl$).

Description Croconazole Hydrochloride occurs as white to pale yellow-white, crystals or crystalline powder.

It is very soluble in water, freely soluble in methanol, in ethanol (95) and in acetic acid (100), and practically insoluble in diethyl ether.

Identification (1) Determine the absorption spectrum of a solution of Croconazole Hydrochloride in methanol (1 in 20,000) as directed under Ultraviolet-visible Spectrophotometry <2.24>, and compare the spectrum with the Refer-

ence Spectrum: both spectra exhibit similar intensities of absorption at the same wavelengths.

(2) Determine the infrared absorption spectrum of Croconazole Hydrochloride, previously dried, as directed in the potassium chloride disk method under Infrared Spectrophotometry <2.25>, and compare the spectrum with the Reference Spectrum: both spectra exhibit similar intensities of absorption at the same wave numbers.

(3) Dissolve 0.05 g of Croconazole Hydrochloride in 10 mL of water, add 2 mL of sodium hydroxide TS and 20 mL of diethyl ether, and shake. Wash the separated aqueous layer with two 10-mL portions of diethyl ether, and acidify the solution with 2 mL of dilute nitric acid: the solution responds to Qualitative Tests <1.09> for chloride.

Melting point <2.60> 148 – 153°C

Purity (1) Heavy metals <1.07>—Proceed with 1.0 g of Croconazole Hydrochloride according to Method 4, and perform the test. Prepare the control solution with 1.0 mL of Standard Lead Solution (not more than 10 ppm).

(2) Related substances—Dissolve 50 mg of Croconazole Hydrochloride in 10 mL of methanol, and use this solution as the sample solution. Pipet 1 mL of the sample solution, add methanol to make exactly 100 mL, and use this solution as the standard solution. Perform the test with these solutions as directed under Thin-layer Chromatography <2.03>. Spot 10 μ L each of the sample solution and standard solution on a plate of silica gel with fluorescent indicator for thin-layer chromatography. Develop the plate with a mixture of ethyl acetate, hexane, methanol and ammonia solution (28) (30:15:5:1) to a distance of about 10 cm, and air-dry the plate. Examine under ultraviolet light (main wavelength: 254 nm): the spots other than the principal spot and the spot of the starting point obtained from the sample solution are not more intense than the spot from the standard solution.

Loss on drying <2.41> Not more than 0.5% (1 g, 60°C, 4 hours).

Residue on ignition <2.44> Not more than 0.1% (1 g).

Assay Weigh accurately about 0.6 g of Croconazole Hydrochloride, previously dried, dissolve in 10 mL of acetic acid (100), add 40 mL of acetic anhydride, and titrate <2.50> with 0.1 mol/L perchloric acid VS [indicator: 1 to 2 drops of a solution of malachite green oxalate in acetic acid (100) (1 in 100)] until the color of the solution changes from blue-green through green to yellow-green. Perform a blank determination in the same manner, and make any necessary correction.

Each mL of 0.1 mol/L perchloric acid VS
= 34.72 mg of $C_{18}H_{15}ClN_2O \cdot HCl$

Containers and storage Containers—Tight containers.
Storage—Light-resistant.

Crospovidone

クロスポビドン

This monograph is harmonized with the European Pharmacopoeia and the U.S. Pharmacopoeia.

The parts of the text that are not harmonized are marked with symbols (◆ ◆).

Information on the harmonization with the European Pharmacopoeia and the U.S. Pharmacopoeia is available on the website of the Pharmaceuticals and Medical Devices Agency.

Crospovidone is a cross-linked polymer of 1-vinyl-2-pyrrolidone.

It contains not less than 11.0% and not more than 12.8% of nitrogen (N: 14.01), calculated on the dried basis.

Two types of Crospovidone are available, depending on the particle size: type A and type B.

◆The label states the type.◆

◆**Description** Crospovidone occurs as a white to pale yellow-powder.

It is practically insoluble in water, in methanol and in ethanol (99.5).

It is hygroscopic.◆

Identification (1) Suspend 1 g of Crospovidone in 10 mL of water, add 0.1 mL of iodine TS, shake for 30 seconds, then add 1 mL of starch TS, and shake: a blue color is not produced within 30 seconds.

(2) When add 0.1 g of Crospovidone to 10 mL of water, shake to suspend, and allow the suspension to stand, a clear liquid is not produced within 15 minutes.

Particle size Weigh accurately about 20 g of Crospovidone, place in a 1000-mL conical flask, add 500 mL of water, shake for 30 minutes, and pour onto an accurately tared No. 235 (63 μ m) sieve, previously washed with hot water and dried at 105°C for a night, and wash the residue with water until the passing water is clear. Dry the residue together with the sieve in a drying machine at 105°C for 5 hours without air-circulation. After cooling down in a desiccator for 30 minutes, weigh the mass of the residue with sieve, and calculate the amount of the residue on the sieve by the following equation: Type A is more than 15%, and type B is not more than 15%.

$$\begin{aligned} &\text{Amount (\%)} \text{ of the residue of Crospovidone on} \\ &\text{No. 235 (63 } \mu\text{m) sieve} \\ &= (M_1 - M_3)/M_2 \times 100 \end{aligned}$$

M_1 : The mass (g) of the residue with sieve after 5 hours drying

M_2 : Amount (g) of Crospovidone taken, calculated on the dried basis

M_3 : Mass (g) of the sieve

Purity ◆(1) Heavy metals <I.07>—Proceed with 2.0 g of Crospovidone according to Method 2, and perform the test. Prepare the control solution with 2.0 mL of Standard Lead Solution (not more than 10 ppm).◆

(2) Water-soluble substances—Place 25.0 g of Crospovidone in a 400-mL beaker, add 200 mL of water, and stir for 1 hour. Transfer the suspension to a 250-mL volumetric flask, rinsing with water, and dilute to volume with water. Allow the bulk of the solids to settle. Filter about 100 mL of

the almost clear supernatant liquid through a 0.45 μ m membrane filter, protected by superimposing a 3 μ m membrane filter. Transfer exactly 50 mL of the clear filtrate to a tared 100-mL beaker, evaporate to dryness and dry at 105 – 110°C for 3 hours: the mass of the residue is not more than 75 mg.

(3) 1-Vinyl-2-pyrrolidone—To 1.250 g of Crospovidone add exactly 50 mL of methanol, and shake for 60 minutes. Leave bulk to settle, filter through a 0.2 μ m membrane filter, and use the filtrate as the sample solution. Separately, dissolve 50 mg of 1-vinyl-2-pyrrolidone in methanol to make exactly 100 mL. Pipet 1 mL of this solution, and add methanol to make exactly 100 mL. To exactly 5 mL of this solution add the mobile phase to make exactly 100 mL, and use this solution as the standard solution. Perform the test with exactly 50 μ L each of the sample solution and standard solution as directed under Liquid Chromatography <2.01> according to the following conditions: the peak area of 1-vinyl-2-pyrrolidone obtained from the sample solution is not larger than that from the standard solution (not more than 10 ppm).

Operating conditions—

Detector: An ultraviolet absorption photometer (wavelength: 235 nm).

Column: Two stainless steel columns, one is 4 mm in inside diameter and 25 mm in length and the other is 4 mm in inside diameter and 250 mm in length, they are packed with octadecylsilanized silica gel for liquid chromatography (5 μ m in particle diameter), and used them as the pre-column and the separation column, respectively.

Column temperature: A constant temperature of about 40°C.

Mobile phase: A mixture of water and acetonitrile (9:1).

Flow rate: 1.0 mL per minute.

Washing of pre-column: After each injection of the sample solution, wash the pre-column by passing the mobile phase backwards, at the same flow rate as applied in the test, for 30 minutes.

System suitability—

System performance: Dissolve 10 mg of 1-vinyl-2-pyrrolidone and 0.50 g of vinyl acetate in methanol to make 100 mL. To 1 mL of this solution add the mobile phase to make 100 mL. When the procedure is run with 50 μ L of this solution under the above operating conditions, 1-vinyl-2-pyrrolidone and vinyl acetate are eluted in this order with the resolution between these peaks being not less than 2.0.

System repeatability: When the test is repeated 6 times with 50 μ L of the standard solution under the above operating conditions, the relative standard deviation of the peak area of 1-vinyl-2-pyrrolidone is not more than 2.0%.

(4) Peroxides—

Method 1: Apply to the sample labeled as type A. Suspend 4.0 g of Crospovidone in 100 mL of water, and use as the sample suspension. To 25 mL of the sample suspension add 2 mL of titanium (III) chloride-sulfuric acid TS, allow to stand for 30 minutes, and filter. Determine the absorbance of the filtrate at 405 nm as directed under Ultraviolet-visible Spectrophotometry <2.24>, using the control, prepared by filtrating the sample suspension and adding 2 mL of diluted sulfuric acid (13 in 100) to 25 mL of this filtrate: not more than 0.35 (not more than 400 ppm expressed as hydrogen peroxide).

Method 2: Apply to the sample labeled as type B. Suspend 2.0 g of Crospovidone in 50 mL of water, and use as the sample suspension. To 10 mL of the sample suspension add water to make 25 mL, add 2 mL of titanium (III) chloride-sulfuric acid TS, allow to stand for 30 minutes, and filter. Determine the absorbance of the filtrate at 405 nm as di-

rected under Ultraviolet-visible Spectrophotometry <2.24>, using the control, prepared by filtrating the sample suspension, adding water to 10 mL of this filtrate to make 25 mL and 2 mL of diluted sulfuric acid (13 in 100): not more than 0.35 (not more than 1000 ppm expressed as hydrogen peroxide).

Loss on drying <2.41> Not more than 5.0% (0.5 g, 105°C, constant mass).

Residue on ignition <2.44> Not more than 0.1% (1 g).

Assay Weigh accurately about 0.1 g of Cropsvidone, place in a Kjeldahl flask, add 5 g of a decomposition accelerator (a powdered mixture of 33 g of potassium sulfate, 1 g of copper (II) sulfate pentahydrate and 1 g of titanium (IV) oxide) and 3 glass beads. Wash any adhering particles from the neck into the flask with a small quantity of water. Add 7 mL of sulfuric acid, allowing it to run down the inside wall of the flask. Gradually heat the flask until the solution has a clear, yellowish-green color, and the inside wall of the flask is free from carbonized material, and then heat for a further 45 minutes. After cooling, cautiously add 20 mL of water, and connect the flask to the distillation apparatus previously washed by passing steam through it. To the absorption flask add 30 mL of a solution of boric acid (1 in 25), 3 drops of bromocresol green-methyl red TS and sufficient water to immerse the lower end of the condenser tube. Add 30 mL of a solution of sodium hydroxide (21 in 50) through a funnel, cautiously rinse the funnel with 10 mL of water, immediately close the clamp attached to the rubber tube, then start the distillation with steam to obtain 80–100 mL of distillate. Remove the absorption flask from the lower end of the condenser tube, rinsing the end part with a small quantity of water, and titrate <2.50> the distillate with 0.025 mol/L sulfuric acid VS until the color of the solution changes from green through pale grayish blue to pale grayish red-purple. Carry out a blank determination in the same manner, and make any necessary correction.

Each mL of 0.025 mol/L sulfuric acid VS
= 0.7003 mg of N

Containers and storage Containers—Tight containers.

Cyanamide

シアナミド



CH₂N₂: 42.04
Aminonitrile
[420-04-2]

Cyanamide contains not less than 97.0% and not more than 101.0% of cyanamide (CH₂N₂), calculated on the anhydrous basis.

Description Cyanamide occurs as white, crystals or crystalline powder.

It is very soluble in water, in methanol, in ethanol (99.5) and in acetone.

The pH of a solution of 1.0 g of Cyanamide in 100 mL of water is between 5.0 and 6.5.

It is hygroscopic.

Melting point: about 46°C

Identification (1) To 1 mL of a solution of Cyanamide (1 in 100) add 1 mL of potassium 1,2-naphthoquinone-4-

sulfonate TS and 0.2 mL of sodium hydroxide TS: a deep red color develops.

(2) Drop one or two drops of a solution of Cyanamide in acetone (1 in 100) onto a potassium bromide disk prepared as directed in the potassium bromide disk method under Infrared Spectrophotometry <2.25>, and air-dry the disk. Determine the infrared absorption spectrum of the disk as directed in the film method under Infrared Spectrophotometry <2.25>, and compare the spectrum with the Reference Spectrum: both spectra exhibit similar intensities of absorption at the same wave numbers.

Purity (1) Clarity and color of solution—Dissolve 1.0 g of Cyanamide in 10 mL of water: the solution is clear and colorless.

(2) Heavy metals <1.07>—Proceed with 2.0 g of Cyanamide according to Method 1, and perform the test. Prepare the control solution with 2.0 mL of Standard Lead Solution (not more than 10 ppm).

Water <2.48> Not more than 1.0% (1 g, volumetric titration, direct titration).

Residue on ignition <2.44> Not more than 0.1% (1 g).

Assay Weigh accurately about 1 g of Cyanamide, and dissolve in water to make exactly 250 mL. Pipet 15 mL of this solution, add 2 to 3 drops of dilute nitric acid, 10 mL of ammonia TS and exactly 50 mL of 0.1 mol/L silver nitrate VS, and allow to stand for 15 minutes with occasional shaking. Add water to make exactly 100 mL, filter, discard the first 20 mL of the filtrate, and pipet 50 mL of the subsequent filtrate. After neutralizing this solution with dilute nitric acid, add 3 mL of dilute nitric acid, and titrate <2.50> the excess silver nitrate with 0.1 mol/L ammonium thiocyanate VS (indicator: 2 mL of ammonium iron (III) sulfate TS). Perform a blank determination in the same manner.

Each mL of 0.1 mol/L silver nitrate VS
= 2.102 mg of CH₂N₂

Containers and storage Containers—Tight containers.
Storage—In a cold place.

Cyanocobalamin

Vitamin B₁₂

シアノコバラミン

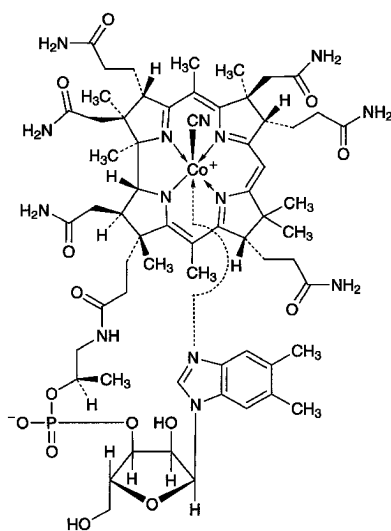
C₆₃H₈₈CoN₁₄O₁₄P: 1355.37

Co α -[α -(5,6-Dimethyl-1*H*-benzimidazol-1-yl)]-Co β -cyanocobamide
[68-19-9]

Cyanocobalamin contains not less than 96.0% and not more than 102.0% of cyanocobalamin (C₆₃H₈₈CoN₁₄O₁₄P), calculated on the dried basis.

Description Cyanocobalamin occurs as dark red, crystals or powder.

It is sparingly soluble in water, and slightly soluble in ethanol (99.5).

It is hygroscopic.

Identification (1) Determine the absorption spectrum of the sample solution obtained in the Assay as directed under Ultraviolet-visible Spectrophotometry <2.24>, and compare the spectrum with the Reference Spectrum or the spectrum of a solution of Cyanocobalamin RS prepared in the same manner as the sample solution: both spectra exhibit similar intensities of absorption at the same wavelengths.

(2) Mix 1 mg of Cyanocobalamin with 50 mg of potassium hydrogen sulfate, and fuse by igniting. Cool, break up the mass with a glass rod, add 3 mL of water, and dissolve by boiling. Add 1 drop of phenolphthalein TS, then add dropwise sodium hydroxide TS until a light red color just develops. Add 0.5 g of sodium acetate trihydrate, 0.5 mL of dilute acetic acid and 0.5 mL of a solution of disodium 1-nitroso-2-naphthol-3,6-disulfonate (1 in 500): a red to orange-red color is immediately produced. Then add 0.5 mL of hydrochloric acid, and boil for 1 minute: the red color does not disappear.

(3) Transfer 5 mg of Cyanocobalamin to a 50-mL distilling flask, dissolve in 5 mL of water, and add 2.5 mL of hypophosphorous acid. Connect the flask with a short condenser, and dips its tip into a test tube containing 1 mL of a solution of sodium hydroxide (1 in 50). Heat gently for 10 minutes, then distil 1 mL into a test tube. To the test tube add 4 drops of a saturated solution of ammonium iron (II) sulfate hexahydrate, shake gently, then add about 30 mg of sodium fluoride, and heat the contents to boil. Immediately

add dropwise diluted sulfuric acid (1 in 7) until a clear solution results, then add 3 to 5 drops more of diluted sulfuric acid (1 in 7): a blue to blue-green color develops.

pH <2.54> Dissolve 0.10 g of Cyanocobalamin in 20 mL of water: the pH of this solution is between 4.2 and 7.0.

Purity (1) Clarity and color of solution—Dissolve 20 mg of Cyanocobalamin in 10 mL of water: the solution is clear and red in color.

(2) Related substances—Conduct this procedure using light-resistant vessels. Dissolve 10 mg of Cyanocobalamin in 10 mL of the mobile phase, and use this solution as the sample solution. Pipet 3 mL of the sample solution, add the mobile phase to make exactly 100 mL, and use this solution as the standard solution. Perform the test with exactly 20 μ L each of the sample solution and standard solution as directed under Liquid Chromatography <2.01> according to the following conditions, and determine each peak area by the automatic integration method: the total area of the peak other than cyanocobalamin obtained from the sample solution is not larger than the peak area of cyanocobalamin from the standard solution.

Operating conditions—

Detector: An ultraviolet absorption photometer (wavelength: 361 nm).

Column: A stainless steel column 4.6 mm in inside diameter and 25 cm in length, packed with octylsilylated silica gel for liquid chromatography (5 μ m in particle diameter).

Column temperature: A constant temperature of about 30°C.

Mobile phase: Dissolve 10 g of anhydrous disodium hydrogen phosphate in 1000 mL of water, and adjust to pH 3.5 with phosphoric acid. To 147 mL of this solution add 53 mL of methanol.

Flow rate: Adjust so that the retention time of cyanocobalamin is about 7 minutes.

Time span of measurement: About 4 times as long as the retention time of cyanocobalamin, beginning after the solvent peak.

System suitability—

Test for required detectability: To 1 mL of the sample solution, add the mobile phase to make 100 mL, and use this solution as the solution for system suitability test. Pipet 1 mL of the solution for system suitability test, and add the mobile phase to make exactly 10 mL. Confirm that the peak area of cyanocobalamin obtained with 20 μ L of this solution is equivalent to 7 to 13% of that with 20 μ L of the solution for system suitability test.

System performance: Perform this procedure quickly after the solution is prepared. To 25 mg of cyanocobalamin add 10 mL of water, and warm, if necessary, to dissolve. After cooling, add 0.5 mL of sodium toluenesulfonchloramide TS, 0.5 mL of 0.05 mol/L hydrochloric acid TS and water to make 25 mL, mix, and allow the solution to stand for 5 minutes. To 1 mL of the solution add the mobile phase to make 10 mL. When the procedure is run with 20 μ L of the solution under the above operating conditions, two principal peaks appear with the resolution between these peaks being not less than 2.5.

System repeatability: When the test is repeated 6 times with 20 μ L of the solution for system suitability test under the above operating conditions, the relative standard deviation of the peak area of cyanocobalamin is not more than 3.0%.

Loss on drying <2.41> Not more than 12% (50 mg, in vacuum at a pressure not exceeding 0.67 kPa, phosphorus (V)

oxide, 100°C, 4 hours).

Assay Weigh accurately about 20 mg each of Cyanocobalamin and Cyanocobalamin RS (previously determine the loss on drying <2.41> under the same conditions as Cyanocobalamin), dissolve in water to make exactly 1000 mL, respectively, and use these solutions as the sample solution and the standard solution. Determine the absorbances, A_T and A_S , of the sample solution and standard solution, at 361 nm as directed under Ultraviolet-visible Spectrophotometry <2.24>.

$$\begin{aligned} &\text{Amount (mg) of cyanocobalamin (C}_{63}\text{H}_{88}\text{CoN}_{14}\text{O}_{14}\text{P)} \\ &= M_S \times A_T / A_S \end{aligned}$$

M_S : Amount (mg) of Cyanocobalamin RS taken, calculated on the dried basis

Containers and storage Containers—Tight containers.
Storage—Light-resistant.

Cyanocobalamin Injection

Vitamin B₁₂ Injection

シアノコバラミン注射液

Cyanocobalamin Injection is an aqueous injection.

It contains not less than 95.0% and not more than 115.0% of the labeled amount of cyanocobalamin (C₆₃H₈₈CoN₁₄O₁₄P: 1355.37).

Method of preparation Prepare as directed under Injections, with Cyanocobalamin.

Description Cyanocobalamin Injection is a clear, light red to red liquid.

Identification Determine the absorption spectrum of the sample solution obtained in the Assay as directed under Ultraviolet-visible Spectrophotometry <2.24>: it exhibits maxima between 277 nm and 279 nm, between 360 nm, and 362 nm and between 548 nm and 552 nm. Determine the absorbances, A_1 and A_2 , of this solution at the wavelengths of maximum absorption between 360 nm and 362 nm, and between 548 nm and 552 nm, respectively: the ratio A_2/A_1 is not less than 0.29 and not more than 0.32.

Bacterial endotoxins <4.01> Less than 0.30 EU/μg.

Extractable volume <6.05> It meets the requirement.

Foreign insoluble matter <6.06> Perform the test according to Method 1: it meets the requirement.

Insoluble particulate matter <6.07> It meets the requirement.

Sterility <4.06> Perform the test according to the Membrane filtration method: it meets the requirement.

Assay Measure exactly a volume of Cyanocobalamin Injection, equivalent to about 2 mg of cyanocobalamin (C₆₃H₈₈CoN₁₄O₁₄P), add water to make exactly 100 mL, and use this solution as the sample solution. Separately, weigh accurately about 20 mg of Cyanocobalamin RS (previously determine the loss on drying <2.41> under the same conditions as Cyanocobalamin), add water to make exactly 1000 mL, and use this solution as the standard solution. Then, proceed as directed in the Assay under Cyanocobalamin.

$$\begin{aligned} &\text{Amount (mg) of cyanocobalamin (C}_{63}\text{H}_{88}\text{CoN}_{14}\text{O}_{14}\text{P)} \\ &= M_S \times A_T / A_S \times 1/10 \end{aligned}$$

M_S : Amount (mg) of Cyanocobalamin RS taken, calculated on the dried basis

Containers and storage Containers—Hermetic containers, and colored containers may be used.

Storage—Light-resistant.

Cyclopentolate Hydrochloride

シクロペントラート塩酸塩

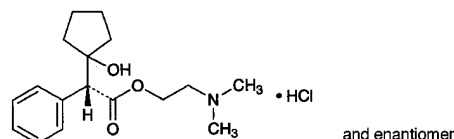

C₁₇H₂₅NO₃·HCl: 327.85

2-(Dimethylamino)ethyl (2*RS*)-2-(1-hydroxycyclopentyl)phenylacetate monohydrochloride [5870-29-1]

Cyclopentolate Hydrochloride, when dried, contains not less than 98.5% of cyclopentolate hydrochloride (C₁₇H₂₅NO₃·HCl).

Description Cyclopentolate Hydrochloride occurs as a white crystalline powder. It is odorless, or has a characteristic odor.

It is very soluble in water, freely soluble in ethanol (95), in acetic acid (100) and in chloroform, sparingly soluble in acetic anhydride, and practically insoluble in diethyl ether.

Identification (1) To 1 mL of a solution of Cyclopentolate Hydrochloride (1 in 100) add 1 mL of Reinecke salt TS: a light red precipitate is formed.

(2) Dissolve 0.2 g of Cyclopentolate Hydrochloride in 2 mL of water, add 2 mL of sodium hydroxide TS, and boil for 1 minute. After cooling, add 2 drops of nitric acid: a phenylacetic acid-like odor is perceptible.

(3) Determine the infrared absorption spectrum of Cyclopentolate Hydrochloride, previously dried, as directed in the potassium chloride disk method under Infrared Spectrophotometry <2.25>, and compare the spectrum with the Reference Spectrum: both spectra exhibit similar intensities of absorption at the same wave numbers.

(4) A solution of Cyclopentolate Hydrochloride (1 in 50) responds to Qualitative Tests <1.09> for chloride.

pH <2.54> Dissolve 0.20 g of Cyclopentolate Hydrochloride in 20 mL of water: the pH of this solution is between 4.5 and 5.5.

Melting point <2.60> 135 – 138°C

Purity (1) Clarity and color of solution—Dissolve 1.0 g of Cyclopentolate Hydrochloride in 10 mL of water: the solution is clear and colorless.

(2) Heavy metals <1.07>—Proceed with 1.0 g of Cyclopentolate Hydrochloride according to Method 1, and perform the test. Prepare the control solution with 2.0 mL of Standard Lead Solution (not more than 20 ppm).

(3) Related substances—Dissolve 0.20 g of Cyclopentolate Hydrochloride in 10 mL of chloroform, and use this solution as the sample solution. Pipet 1 mL of the sample solution, and add chloroform to make exactly 20 mL. Pipet 1 mL of this solution, add chloroform to make exactly 10 mL, and use this solution as the standard solution. Perform the test with these solutions as directed under Thin-layer Chromatography <2.27>.

matography <2.03>. Spot 10 μL each of the sample solution and standard solution on a plate of silica gel for thin-layer chromatography. Develop the plate with a mixture of 2-propanol, *n*-butyl acetate, water and ammonia solution (28) (100:60:23:17) to a distance of about 10 cm, and air-dry the plate. Spray evenly a solution of sulfuric acid in ethanol (99.5) (1 in 10) on the plate, and heat the plate at 120°C for 30 minutes. Examine under ultraviolet light (main wavelength: 254 nm): the spots other than the principal spot obtained from the sample solution are not more intense than the spot from the standard solution.

Loss on drying <2.41> Not more than 0.5% (1 g, 105°C, 4 hours).

Residue on ignition <2.44> Not more than 0.05% (1 g).

Assay Weigh accurately about 0.5 g of Cyclophosphamide Hydrate, previously dried, dissolve in 50 mL of a mixture of acetic anhydride and acetic acid (100) (4:1), and titrate <2.50> with 0.1 mol/L perchloric acid VS until the color of the solution changes from purple through blue-green to yellow-green (indicator: 2 drops of crystal violet TS). Perform a blank determination in the same manner, and make any necessary correction.

Each mL of 0.1 mol/L perchloric acid VS
= 32.79 mg of $\text{C}_7\text{H}_{15}\text{Cl}_2\text{N}_2\text{O}_2\text{P}\cdot\text{H}_2\text{O}$

Containers and storage Containers—Tight containers.

Cyclophosphamide Hydrate

シクロホスファミド水和物

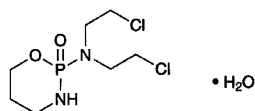

$\text{C}_7\text{H}_{15}\text{Cl}_2\text{N}_2\text{O}_2\text{P}\cdot\text{H}_2\text{O}$: 279.10
N,N-Bis(2-chloroethyl)-3,4,5,6-tetrahydro-2*H*-1,3,2-oxazaphosphorin-2-amine 2-oxide monohydrate
[6055-19-2]

Cyclophosphamide Hydrate contains not less than 97.0% of cyclophosphamide hydrate ($\text{C}_7\text{H}_{15}\text{Cl}_2\text{N}_2\text{O}_2\text{P}\cdot\text{H}_2\text{O}$).

Description Cyclophosphamide Hydrate occurs as white, crystals or crystalline powder. It is odorless.

It is very soluble in acetic acid (100), freely soluble in ethanol (95), in acetic anhydride and in chloroform, and soluble in water and in diethyl ether.

Melting point: 45 – 53°C

Identification (1) Dissolve 0.1 g of Cyclophosphamide Hydrate in 10 mL of water, and add 5 mL of silver nitrate TS: no precipitate is produced. Then boil this solution: a white precipitate is produced. Collect the precipitate, and add dilute nitric acid to a portion of this precipitate: it does not dissolve. Add excess ammonia TS to another portion of the precipitate: it dissolves.

(2) Add 1 mL of diluted sulfuric acid (1 in 25) to 0.02 g of Cyclophosphamide Hydrate, and heat until white fumes are evolved. After cooling, add 5 mL of water, and shake. Neutralize with ammonia TS, then acidify with dilute nitric acid: this solution responds to Qualitative Tests <1.09> (2) for phosphate.

Purity (1) Clarity and color of solution—Dissolve 0.20 g of Cyclophosphamide Hydrate in 10 mL of water: the solution is clear and colorless.

(2) Chloride <1.03>—Perform the test with 0.40 g of Cyclophosphamide Hydrate at a temperature not exceeding 20°C. Prepare the control solution with 0.40 mL of 0.01 mol/L hydrochloric acid VS (not more than 0.036%).

(3) Heavy metals <1.07>—Proceed with 1.0 g of Cyclophosphamide Hydrate according to Method 1, and perform the test. Prepare the control solution with 2.0 mL of Standard Lead Solution (not more than 20 ppm).

Water <2.48> 5.5 – 7.0% (0.5 g, volumetric titration, direct titration).

Assay Weigh accurately about 0.3 g of Cyclophosphamide Hydrate, add 15 mL of hydrogen chloride-ethanol TS, and heat in a water bath under a reflux condenser for 3.5 hours while protecting from moisture. Distil the ethanol under reduced pressure. Dissolve the residue in 40 mL of a mixture of acetic anhydride and acetic acid (100) (7:3), and titrate <2.50> with 0.1 mol/L perchloric acid-dioxane VS (indicator: 2 drops of crystal violet TS) until the color of the solution changes from blue through green to yellow. Perform a blank determination in the same manner, and make any necessary correction.

Each mL of 0.1 mol/L perchloric acid-dioxane VS
= 13.96 mg of $\text{C}_7\text{H}_{15}\text{Cl}_2\text{N}_2\text{O}_2\text{P}\cdot\text{H}_2\text{O}$

Containers and storage Containers—Tight containers.
Storage—Not exceeding 30°C.

Cyclophosphamide Tablets

シクロホスファミド錠

Cyclophosphamide Tablets contain not less than 93.0% and not more than 107.0% of the labeled amount of cyclophosphamide hydrate ($\text{C}_7\text{H}_{15}\text{Cl}_2\text{N}_2\text{O}_2\text{P}\cdot\text{H}_2\text{O}$: 279.10).

Method of preparation Prepare as directed under Tablets, with Cyclophosphamide Hydrate.

Identification To Cyclophosphamide Tablets add 1 mL of water for every 53 mg of Cyclophosphamide Hydrate, shake vigorously for 5 minutes, add 6 mL of methanol for every 53 mg of Cyclophosphamide Hydrate, and shake vigorously for 10 minutes. To this solution add methanol so that each mL contains about 5.3 mg of Cyclophosphamide Hydrate, and centrifuge. Filter the supernatant liquid through a membrane filter with a pore size not exceeding 0.45 μm . Discard not less than 3 mL of the first filtrate, and use the subsequent filtrate as the sample solution. Separately, dissolve 53 mg of cyclophosphamide hydrate for assay in 10 mL of a mixture of methanol and water (9:1), and use this solution as the standard solution. Perform the test with these solutions as directed under Thin-layer Chromatography <2.03>. Spot 2 μL each of the sample solution and standard solution on a plate of silica gel for thin-layer chromatography. Develop the plate with a mixture of 1-propanol and water (8:1) to a distance of about 10 cm, and air-dry the plate. Heat the plate at 130°C for 15 minutes. After cooling, spray evenly ninhydrin-butanol TS on the plate, and after air-drying heat at 130°C for 10 minutes: the principal spot obtained from the sample solution and the spot from the standard solution show a red-purple color and the same *R_f* value.

Uniformity of dosage units <6.02> Perform the test according to the following method: it meets the requirement of the Content uniformity test.

To 1 tablet of Cyclophosphamide Tablets add 3V/5 mL of a mixture of water and methanol (3:2), and shake vigorously to homogeneously disperse the tablet. To this solution add a mixture of water and methanol (3:2) to make exactly V mL so that each mL contains about 1.1 mg of cyclophosphamide hydrate (C₇H₁₅Cl₂N₂O₂P.H₂O), and centrifuge. Filter the supernatant liquid through a membrane filter with a pore size not exceeding 0.45 μm. Discard the first 3 mL of the filtrate, and use the subsequent filtrate as the sample solution. Then, proceed as directed in the Assay.

$$\begin{aligned} & \text{Amount (mg) of cyclophosphamide hydrate} \\ & (\text{C}_7\text{H}_{15}\text{Cl}_2\text{N}_2\text{O}_2\text{P.H}_2\text{O}) \\ & = M_S \times A_T/A_S \times V/50 \end{aligned}$$

M_S: Amount (mg) of cyclophosphamide hydrate for assay taken

Dissolution <6.10> When the test is performed at 100 revolutions per minute according to the Basket method, using 900 mL of water as the dissolution medium, the dissolution rate in 45 minutes of Cyclophosphamide Tablets is not less than 80%.

Start the test with 1 tablet of Cyclophosphamide Tablets, withdraw not less than 20 mL of the medium at the specified minute after starting the test, and filter through a membrane filter with a pore size not exceeding 0.45 μm. Discard not less than 10 mL of the first filtrate, pipet V' mL of the subsequent filtrate, add water to make exactly V' mL so that each mL contains about 59 μg of cyclophosphamide hydrate (C₇H₁₅Cl₂N₂O₂P.H₂O) and use this solution as the sample solution. Separately, weigh accurately about 30 mg of cyclophosphamide hydrate for assay, and dissolve in water to make exactly 50 mL. Pipet 2 mL of this solution, add water to make exactly 20 mL, and use this solution as the standard solution. Perform the test with exactly 50 μL each of the sample solution and standard solution as directed under Liquid Chromatography <2.01> according to the following conditions and determine the peak areas, A_T and A_S, of cyclophosphamide in each solution.

$$\begin{aligned} & \text{Dissolution rate (\%)} \text{ with respect to the labeled amount} \\ & \text{of cyclophosphamide hydrate (C}_7\text{H}_{15}\text{Cl}_2\text{N}_2\text{O}_2\text{P.H}_2\text{O)} \\ & = M_S \times A_T/A_S \times V'/V \times 1/C \times 180 \end{aligned}$$

M_S: Amount (mg) of cyclophosphamide hydrate for assay taken

C: Labeled amount (mg) of cyclophosphamide hydrate (C₇H₁₅Cl₂N₂O₂P.H₂O) in 1 tablet

Operating conditions—

Proceed as directed in the operating conditions in the Assay.

System suitability—

System performance: When the procedure is run with 50 μL of the standard solution under the above operating conditions, the number of theoretical plates and the symmetry factor of the peak of cyclophosphamide are not less than 5000 and not more than 1.5, respectively.

System repeatability: When the test is repeated 6 times with 50 μL of the standard solution under the above operating conditions, the relative standard deviation of the peak area of cyclophosphamide is not more than 2.0%.

Assay To 10 tablets of Cyclophosphamide Tablets add 13V/20 mL of a mixture of water and methanol (3:2), and shake vigorously to homogeneously disperse the tablets. To

this solution add a mixture of water and methanol (3:2) to make exactly V mL so that each mL contains about 2.7 mg of cyclophosphamide hydrate (C₇H₁₅Cl₂N₂O₂P.H₂O), and centrifuge. Filter the supernatant liquid through a membrane filter with a pore size not exceeding 0.45 μm. Discard the first 3 mL of the filtrate, pipet 4 mL of the subsequent filtrate, add a mixture of water and methanol (3:2) to make exactly 10 mL, and use this solution as the sample solution. Separately, weigh accurately about 53 mg of cyclophosphamide hydrate for assay, dissolve in a mixture of water and methanol (3:2) to make exactly 50 mL, and use this solution as the standard solution. Perform the test with exactly 20 μL each of the sample solution and standard solution as directed under Liquid Chromatography <2.01> according to the following conditions, and determine the peak area, A_T and A_S, of cyclophosphamide in each solution.

$$\begin{aligned} & \text{Amount (mg) of cyclophosphamide hydrate} \\ & (\text{C}_7\text{H}_{15}\text{Cl}_2\text{N}_2\text{O}_2\text{P.H}_2\text{O}) \\ & = M_S \times A_T/A_S \times V/200 \end{aligned}$$

M_S: Amount (mg) of cyclophosphamide hydrate for assay taken

Operating conditions—

Detector: An ultraviolet absorption photometer (wavelength: 205 nm).

Column: A stainless steel column 4.6 mm in inside diameter and 15 cm in length, packed with octadecylsilanized silica gel for liquid chromatography (5 μm in particle diameter).

Column temperature: A constant temperature of about 25°C.

Mobile phase: A mixture of water and methanol (3:2).

Flow rate: Adjust so that the retention time of cyclophosphamide is about 10 minutes.

System suitability—

System performance: When the procedure is run with 20 μL of the standard solution under the above operating conditions, the number of theoretical plates and the symmetry factor of the peak of cyclophosphamide are not less than 4000 and not more than 1.5, respectively.

System repeatability: When the test is repeated 6 times with 20 μL of the standard solution under the above operating conditions, the relative standard deviation of the peak area of cyclophosphamide is not more than 1.0%.

Containers and storage Containers—Tight containers.

Cycloserine

サイクロセリン

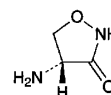

C₃H₆N₂O₂: 102.09

(4R)-4-Aminoisoxazolidin-3-one
[68-41-7]

Cycloserine contains not less than 950 μg (potency) and not more than 1020 μg (potency) per mg, calculated on the dried basis. The potency of Cycloserine is expressed as mass (potency) of cycloserine (C₃H₆N₂O₂).

Description Cycloserine occurs as white to light yellow-white, crystals or crystalline powder.

It is soluble in water, and sparingly soluble in ethanol (95).

Identification Determine the infrared absorption spectrum of Cycloserine, previously dried, as directed in the potassium bromide disk method under Infrared Spectrophotometry <2.25>, and compare the spectrum with the Reference Spectrum or the spectrum of previously dried Cycloserine RS: both spectra exhibit similar intensities of absorption at the same wave numbers.

Optical rotation <2.49> $[\alpha]_D^{20}$: +108 – +114° (2.5 g calculated on the dried basis, 2 mol/L sodium hydroxide TS, 50 mL, 100 mm).

pH <2.54> Dissolve 1.0 g of Cycloserine in 20 mL of water: the pH of the solution is between 5.0 and 7.4.

Purity (1) Heavy metals <1.07>—Proceed with 1.0 g of Cycloserine according to Method 4, and perform the test. Prepare the control solution with 2.0 mL of Standard Lead Solution (not more than 20 ppm).

(2) Condensation products—Dissolve 20 mg of Cycloserine in sodium hydroxide TS to make exactly 50 mL, and determine the absorbance of this solution at 285 nm as directed under Ultraviolet-visible Spectrophotometry <2.24>: not more than 0.8.

Loss on drying <2.41> Not more than 1.5% (0.5 g, reduced pressure, 60°C, 3 hours).

Residue on ignition <2.44> Not more than 0.5% (1 g).

Assay Perform the test according to the Cylinder-plate method as directed under Microbial Assay for Antibiotics <4.02> according to the following conditions.

(i) Test organism—*Bacillus subtilis* ATCC 6633

(ii) Culture medium—Use the medium i in 1) Medium for test organism [5] under (1) Agar media for seed and base layer. Adjust the pH of the medium so that it will be 6.0 to 6.1 after sterilization.

(iii) Standard solutions—Weigh accurately an amount of Cycloserine RS, previously dried at 60°C for 3 hours under reduced pressure of not exceeding 0.67 kPa, equivalent to about 40 mg (potency), dissolve in water to make exactly 100 mL, and use this solution as the standard stock solution. Keep the standard stock solution at 5°C or below and use within 24 hours. Take exactly a suitable amount of the standard stock solution before use, and add phosphate buffer solution (pH 6.0) to make solutions so that each mL contains 100 µg (potency) and 50 µg (potency), and use these solutions as the high concentration standard solution and the low concentration standard solution, respectively.

(iv) Sample solutions—Weigh accurately an amount of Cycloserine equivalent to about 40 mg (potency), dissolve in water to make exactly 100 mL. Take exactly a suitable amount of this solution, add phosphate buffer solution (pH 6.0) to make solutions so that each mL contains 100 µg (potency) and 50 µg (potency), and use these solutions as the high concentration sample solution and the low concentration sample solution, respectively.

Containers and storage Containers—Well-closed containers.

Cyproheptadine Hydrochloride Hydrate

シプロヘプタジン塩酸塩水和物

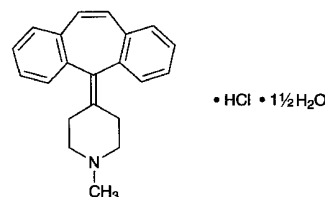

$C_{21}H_{21}N \cdot HCl \cdot \frac{1}{2}H_2O$: 350.88
4-(5*H*-Dibenzo[*a,d*]cyclohepten-5-ylidene)-1-methylpiperidine monohydrochloride sesquihydrate
[41354-29-4]

Cyproheptadine Hydrochloride Hydrate, when dried, contains not less than 98.5% of cyproheptadine hydrochloride ($C_{21}H_{21}N \cdot HCl$: 323.86).

Description Cyproheptadine Hydrochloride Hydrate occurs as a white to pale yellow crystalline powder. It is odorless, and has a slightly bitter taste.

It is freely soluble in methanol and in acetic acid (100), soluble in chloroform, sparingly soluble in ethanol (95), slightly soluble in water, and practically insoluble in diethyl ether.

Identification (1) Dissolve 0.1 g of Cyproheptadine Hydrochloride Hydrate in 10 mL of methanol, apply 1 drop of this solution on filter paper, air-dry, and examine under ultraviolet light (main wavelength: 254 nm): the solution shows a pale blue fluorescence.

(2) Weigh 0.1 g of Cyproheptadine Hydrochloride Hydrate, transfer to a separator, dissolve in 5 mL of chloroform, add 4 mL of water and 1 mL of sodium carbonate TS, and shake. Transfer the chloroform layer to another separator, and wash with 4 mL of water by shaking well. Filter the chloroform layer through absorbent cotton moistened previously with chloroform, and evaporate the filtrate to dryness. Dissolve the residue in 8 mL of dilute ethanol by warming at 65°C. Rub the inner wall of the container with a glass rod while cooling until crystallization begins, and allow to stand for 30 minutes. Collect the crystals, and dry at 80°C for 2 hours: the crystals melt <2.60> between 111°C and 115°C.

(3) Determine the absorption spectrum of a solution of Cyproheptadine Hydrochloride Hydrate in ethanol (95) (1 in 100,000) as directed under Ultraviolet-visible Spectrophotometry <2.24>, and compare the spectrum with the Reference Spectrum: both spectra exhibit similar intensities of absorption at the same wavelengths.

(4) A saturated solution of Cyproheptadine Hydrochloride Hydrate responds to Qualitative Tests <1.09> (2) for chloride.

Purity (1) Acidity—Dissolve 2.0 g of Cyproheptadine Hydrochloride Hydrate in 25 mL of methanol, and add 1 drop of methyl red TS and 0.30 mL of 0.1 mol/L sodium hydroxide VS: a yellow color develops.

(2) Heavy metals <1.07>—Proceed with 1.0 g of Cyproheptadine Hydrochloride Hydrate according to Method 2, and perform the test. Prepare the control solution with 2.0 mL of Standard Lead Solution (not more than 20 ppm).

Loss on drying <2.41> 7.0 – 9.0% (1 g, in vacuum at a pres-

sure not exceeding 0.67 kPa, 100°C, 5 hours).

Residue on ignition <2.44> Not more than 0.1% (1 g).

Assay Weigh accurately about 0.5 g of Cyproheptadine Hydrochloride Hydrate, previously dried, and dissolve in 20 mL of acetic acid (100) by warming at 50°C. After cooling, add 40 mL of acetic anhydride, and titrate <2.50> with 0.1 mol/L perchloric acid VS (potentiometric titration). Perform a blank determination in the same manner, and make any necessary correction.

Each mL of 0.1 mol/L perchloric acid VS
= 32.39 mg of C₂₁H₂₁N.HCl

Containers and storage Containers—Well-closed containers.

L-Cysteine

L-システイン

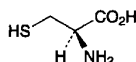

C₃H₇NO₂S: 121.16

(2*R*)-2-Amino-3-sulfanylpropanoic acid
[52-90-4]

L-Cysteine contains not less than 98.5% and not more than 101.0% of L-cysteine (C₃H₇NO₂S), calculated on the dried basis.

Description L-Cysteine occurs as white crystals or a white crystalline powder. It has a characteristic odor and a pungent taste.

It is freely soluble in water, and practically insoluble in ethanol (99.5).

It dissolves in 1 mol/L hydrochloric acid TS.

Identification Determine the infrared absorption spectrum of L-Cysteine as directed in the potassium bromide disk method under Infrared Spectrophotometry <2.25>, and compare the spectrum with the Reference Spectrum: both spectra exhibit similar intensities of absorption at the same wave numbers.

Optical rotation <2.49> [α]_D²⁰: +8.0 – +10.0° (2 g calculated on the dried basis, 1 mol/L hydrochloric acid TS, 25 mL, 100 mm).

pH <2.54> The pH of a solution prepared by dissolving 1.25 g of L-Cysteine in 50 mL of water is 4.7 to 5.7.

Purity (1) Clarity and color of solution—Dissolve 1.0 g of L-Cysteine in 20 mL of water: the solution is clear and colorless.

(2) Chloride <1.03>—Dissolve 0.30 g of L-Cysteine in 10 mL of diluted nitric acid (1 in 4), add 10 mL of hydrogen peroxide (30), heat for 20 minutes in a boiling water bath, cool, and then add water to make 50 mL. Perform the test using this solution as the test solution. Prepare the control solution with 0.35 mL of 0.01 mol/L hydrochloric acid VS (not more than 0.041%).

(3) Sulfate <1.14>—Dissolve 0.6 g of L-Cysteine in 30 mL of water and 3 mL of dilute hydrochloric acid, and add water to make 50 mL. Perform the test using this solution as the test solution. Prepare the control solution as follows: To 0.35 mL of 0.005 mol/L sulfuric acid VS add 3 mL of dilute hydrochloric acid and water to make 50 mL. Prepare the test

solution and the control solution with 4 mL of barium chloride TS, respectively (not more than 0.028%).

(4) Ammonium <1.02>—Perform the test with 0.25 g of L-Cysteine, using the distillation under reduced pressure. Prepare the control solution with 5.0 mL of Standard Ammonium Solution (not more than 0.02%).

(5) Heavy metals <1.07>—Proceed with 1.0 g of L-Cysteine according to Method 4, and perform the test. Prepare the control solution with 1.0 mL of Standard Lead Solution (not more than 10 ppm).

(6) Iron <1.10>—Prepare the test solution with 1.0 g of L-Cysteine according to Method 1, and perform the test according to Method A. Prepare the control solution with 1.0 mL of Standard Iron Solution (not more than 10 ppm).

(7) Related substances—Dissolve 0.10 g of L-Cysteine in *N*-ethylmaleimide solution (1 in 50) to make exactly 10 mL, leave for 30 minutes, and use this solution as the sample solution. Pipet 1 mL of the sample solution, add water to make exactly 10 mL, pipet 1 mL of this solution, add water to make exactly 50 mL, and use this solution as the standard solution (1). Separately, dissolve 0.10 g of L-cystine in 0.5 mol/L hydrochloric acid TS to make exactly 20 mL. Pipet 1 mL of this solution, add water to make 100 mL, and use this solution as the standard solution (2). Perform the test with these solutions as directed under Thin-layer Chromatography <2.03>. Spot 10 μ L each of the sample solution and standard solutions (1) and (2) on a plate of silica gel for thin-layer chromatography. Develop the plate with a mixture of 1-butanol, water, and acetic acid (100) (3:1:1) to a distance of about 10 cm, and dry the plate for 30 minutes at 80°C. Spray the plate evenly with a solution of ninhydrin in a mixture of methanol and acetic acid (100) (97:3) (1 in 100), and then heat at 80°C for 10 minutes: the spot obtained from the sample solution corresponding to the spot from the standard solution (2) is not more intense than the spot from the standard solution (2). Also, the spots other than the principal spot and the spots mentioned above from the sample solution are not more intense than the spot from the standard solution (1).

Loss on drying <2.41> Not more than 0.5% (1 g, in vacuum, phosphorus (V) oxide, 3 hours).

Residue on ignition <2.44> Not more than 0.1% (1 g).

Assay Weigh accurately about 0.2 g of L-Cysteine, place it in a stoppered flask, and dissolve in 20 mL of water. Dissolve 4 g of potassium iodide in this solution, immediately place in ice cold water, add 5 mL of dilute hydrochloric acid and exactly 25 mL of 0.05 mol/L iodine VS, leave in a dark place for 20 minutes, and then titrate <2.50> an excess amount of iodine with 0.1 mol/L sodium thiosulfate VS (indicator: starch TS). Perform a blank determination in the same manner.

Each mL of 0.05 mol/L iodine VS = 12.12 mg of C₃H₇NO₂S

Containers and storage Containers—Tight containers.

L-Cysteine Hydrochloride Hydrate

L-システイン塩酸塩水和物

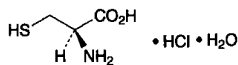

$C_3H_7NO_2S \cdot HCl \cdot H_2O$: 175.63
(2*R*)-2-Amino-3-sulfanypropanoic acid monohydrochloride monohydrate
[7048-04-6]

L-Cysteine Hydrochloride Hydrate contains not less than 98.5% and not more than 101.0% of L-cysteine hydrochloride ($C_3H_7NO_2S \cdot HCl$: 157.62), calculated on the dried basis.

Description L-Cysteine Hydrochloride Hydrate occurs as white, crystals or crystalline powder. It has a characteristic odor and a strong acid taste.

It is very soluble in water, and soluble in ethanol (99.5).

It dissolves in 6 mol/L hydrochloric acid TS.

Identification (1) Determine the infrared absorption spectrum of L-Cysteine Hydrochloride Hydrate as directed in the potassium chloride disk method under Infrared Spectrophotometry <2.25>, and compare the spectrum with the Reference Spectrum: both spectra exhibit similar intensities of absorption at the same wave numbers.

(2) To 10 mL of a solution of L-Cysteine Hydrochloride Hydrate (1 in 50) add 1 mL of hydrogen peroxide (30), heat on a water bath for 20 minutes, and cool: the solution responds to Qualitative Tests <1.09> (2) for chloride.

Optical rotation <2.49> $[\alpha]_D^{20}$: +6.0 – +7.5° (2 g, calculated on the dried basis, 6 mol/L hydrochloric acid TS, 25 mL, 100 mm).

pH <2.54> The pH of a solution prepared by dissolving 1.0 g of L-Cysteine Hydrochloride Hydrate in 100 mL of water is between 1.3 and 2.3.

Purity (1) Clarity and color of solution—A solution obtained by dissolving 1.0 g of L-Cysteine Hydrochloride Hydrate in 10 mL of water is clear and colorless.

(2) Sulfate <1.14>—Dissolve 0.8 g of L-Cysteine Hydrochloride Hydrate in 30 mL of water and 3 mL of dilute hydrochloric acid, and add water to make 50 mL. Perform the test using this solution as the test solution. Prepare the control solution as follows: To 0.35 mL of 0.005 mol/L sulfuric acid VS add 3 mL of dilute hydrochloric acid and water to make 50 mL. To both of the test solution and the control solution add 4 mL of barium chloride TS (not more than 0.021%).

(3) Ammonium <1.02>—Perform the test with 0.25 g of L-Cysteine Hydrochloride Hydrate using the distillation under reduced pressure. Prepare the control solution with 5.0 mL of Standard Ammonium Solution (not more than 0.02%).

(4) Heavy metals <1.07>—Proceed with 1.0 g of L-Cysteine Hydrochloride Hydrate according to Method 4, and perform the test. Prepare the control solution with 1.0 mL of Standard Lead Solution (not more than 10 ppm).

(5) Iron <1.10>—Prepare the test solution with 1.0 g of L-Cysteine Hydrochloride Hydrate according to Method 1, and perform the test according to Method A. Prepare the control solution with 1.0 mL of Standard Iron Solution (not more than 10 ppm).

(6) Related substances—Dissolve 0.10 g of L-Cysteine Hydrochloride Hydrate in *N*-ethylmaleimide solution (1 in 50) to make 10 mL, allow to stand for 30 minutes, and use this solution as the sample solution. Pipet 1 mL of the sample solution, add water to make exactly 10 mL. Pipet 1 mL of this solution, add water to make exactly 50 mL, and use this solution as the standard solution. Perform the test with these solutions as directed under Thin-Layer Chromatography <2.03>. Spot 5 μ L each of the sample solution and standard solution on a plate of silica gel for thin-layer chromatography. Then develop with a mixture of 1-butanol, water and acetic acid (100) (3:1:1) to a distance of about 10 cm, and dry the plate at 80°C for 30 minutes. Spray evenly a solution of ninhydrin in a mixture of methanol and acetic acid (100) (97:3) (1 in 100) on the plate, and then heat at 80°C for 10 minutes: the spot other than the principal spot obtained from the sample solution is not more intense than the spot from the standard solution.

Loss on drying <2.41> 8.5 – 12.0% (1 g, in vacuum, phosphorus (V) oxide, 20 hours).

Residue on ignition <2.44> Not more than 0.1% (1 g).

Assay Weigh accurately about 0.25 g of L-Cysteine Hydrochloride Hydrate, place in a glass-stoppered flask, and dissolve in 20 mL of water. Dissolve 4 g of potassium iodide in this solution, soak immediately in ice cold water, add 5 mL of dilute hydrochloric acid and exactly 25 mL of 0.05 mol/L iodine VS, allow to stand for 20 minutes in a dark place, titrate <2.50> the excess of iodine with 0.1 mol/L sodium thiosulfate VS (indicator: starch TS). Perform a blank determination in the same manner, and make any necessary correction.

Each mL of 0.05 mol/L iodine VS
= 15.76 mg of $C_3H_7NO_2S \cdot HCl$

Containers and storage Containers—Tight containers.

L-Cystine

L-シスチン

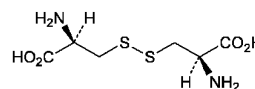

$C_6H_{12}N_2O_4S_2$: 240.30
3,3'-Disulfanediylylbis[(2*R*)-2-aminopropanoic acid]
[56-89-3]

L-Cystine, when dried, contains not less than 99.0% and not more than 101.0% of L-cystine ($C_6H_{12}N_2O_4S_2$).

Description L-Cystine occurs as white, crystals or crystalline powder.

It is practically insoluble in water and in ethanol (99.5).

It dissolves in 1 mol/L hydrochloric acid TS.

Identification Determine the infrared absorption spectrum of L-Cystine as directed in the potassium bromide disk method under Infrared Spectrophotometry <2.25>, and compare the spectrum with the Reference Spectrum: both spectra exhibit similar intensities of absorption at the same wave numbers.

Optical rotation <2.49> $[\alpha]_D^{20}$: –215 – –225° (after drying, 1 g, 1 mol/L hydrochloric acid TS, 50 mL, 100 mm).

Purity (1) Clarity and color of solution—A solution obtained by dissolving 1.0 g of L-Cystine in 10 mL of 2 mol/L hydrochloric acid TS is clear and colorless.

(2) Chloride <1.03>—Dissolve 0.5 g of L-Cystine in 10 mL of dilute nitric acid, add 10 mL of hydrogen peroxide (30), and heat in a water bath for 10 minutes. After cooling, add water to make 50 mL, and perform the test using this solution as the test solution. Prepare the control solution with 0.30 mL of 0.01 mol/L hydrochloric acid VS (not more than 0.021%).

(3) Sulfate <1.14>—Dissolve 0.6 g of L-Cystine in 5 mL of dilute hydrochloric acid, add water to make 45 mL, and perform the test using this solution as the test solution. Prepare the control solution as follows: To 0.35 mL of 0.005 mol/L sulfuric acid VS add 5 mL of dilute hydrochloric acid and water to make 45 mL. To both the test and control solutions add 5 mL of barium chloride TS (not more than 0.028%).

(4) Ammonium <1.02>—Perform the test with 0.25 g of L-Cystine, using the distillation under reduced pressure. Prepare the control solution with 5.0 mL of Standard Ammonium Solution (not more than 0.02%).

(5) Heavy metals <1.07>—Proceed with 1.0 g of L-Cystine according to Method 4, and perform the test. Prepare the control solution with 1.0 mL of Standard Lead Solution (not more than 10 ppm).

(6) Iron <1.10>—Prepare the test solution with 1.0 g of L-Cystine according to Method 3, and perform the test according to Method A. Prepare the control solution with 1.0 mL of Standard Iron Solution (not more than 10 ppm).

(7) Related substances—Dissolve 0.20 g of L-Cystine in 20 mL of 1 mol/L hydrochloric acid TS, and use this solution as the sample solution. Pipet 1 mL of the sample solution, and add water to make exactly 10 mL. Pipet 1 mL of this solution, add water to make exactly 50 mL, and use this solution as the standard solution. Perform the test with these solutions as directed under Thin-layer Chromatography <2.03>. Spot 5 μ L each of the sample solution and standard solution on a plate of silica gel for thin-layer chromatography. Develop the plate with a mixture of 1-propanol and ammonia solution (28) (67:33) to a distance of about 10 cm, and dry the plate at 80°C for 30 minutes. Spray evenly a solution of ninhydrin in a mixture of methanol and acetic acid (100) (97:3) (1 in 100) on the plate, and heat the plate at 80°C for 10 minutes: the spot other than the principal spot obtained from the sample solution is not more intense than the spot from the standard solution.

Loss on drying <2.41> Not more than 0.3% (1 g, 105°C, 3 hours).

Residue on ignition <2.44> Not more than 0.1% (1 g).

Assay Weigh accurately about 30 mg of L-Cystine, previously dried, and perform the test as directed under Nitrogen Determination <1.08>.

$$\begin{aligned} \text{Each mL of 0.005 mol/L sulfuric acid VS} \\ = 1.202 \text{ mg of } \text{C}_6\text{H}_{12}\text{N}_2\text{O}_4\text{S}_2 \end{aligned}$$

Containers and storage Containers—Tight containers.
Storage—Light-resistant.

Cytarabine

シタラビン

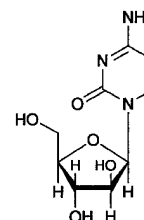

$\text{C}_9\text{H}_{13}\text{N}_3\text{O}_5$: 243.22

1- β -D-Arabinofuranosylcytosine
[147-94-4]

Cytarabine, when dried, contains not less than 98.5% and not more than 101.0% of cytarabine ($\text{C}_9\text{H}_{13}\text{N}_3\text{O}_5$).

Description Cytarabine occurs as white, crystals or crystalline powder.

It is freely soluble in water, soluble in acetic acid (100), and very slightly soluble in ethanol (99.5).

It dissolves in 0.1 mol/L hydrochloric acid TS.

Melting point: about 214°C (with decomposition).

Identification (1) Determine the absorption spectrum of a solution of Cytarabine in 0.1 mol/L hydrochloric acid TS (1 in 100,000) as directed under Ultraviolet-visible Spectrophotometry <2.24>, and compare the spectrum with the Reference Spectrum: both spectra exhibit similar intensities of absorption at the same wavelengths.

(2) Determine the infrared absorption spectrum of Cytarabine as directed in the potassium bromide disk method under Infrared Spectrophotometry <2.25>, and compare the spectrum with the Reference Spectrum: both spectra exhibit similar intensities of absorption at the same wave numbers.

Optical rotation <2.49> $[\alpha]_{\text{D}}^{20}$: +154 – +160° (after drying, 0.1 g, water, 10 mL, 100 mm).

pH <2.54> Dissolve 0.20 g of Cytarabine in 20 mL of water: the pH of this solution is between 6.5 and 8.0.

Purity (1) Clarity and color of solution—Dissolve 1.0 g of Cytarabine in 10 mL of water: the solution is clear and colorless.

(2) Chloride <1.03>—Perform the test with 1.0 g of Cytarabine. Prepare the control solution with 0.25 mL of 0.01 mol/L hydrochloric acid VS (not more than 0.009%).

(3) Heavy metals <1.07>—Proceed with 1.0 g of Cytarabine according to Method 1, and perform the test. Prepare the control solution with 2.0 mL of Standard Lead Solution (not more than 20 ppm).

(4) Related substances—Dissolve 0.10 g of Cytarabine in 10 mL of water, and use this solution as the sample solution. Pipet 1 mL of the sample solution, add water to make exactly 200 mL, and use this solution as the standard solution (1). Pipet 10 mL of the standard solution (1), add water to make exactly 25 mL and use this solution as the standard solution (2). Perform the test with these solutions as directed under Thin-layer Chromatography <2.03>. Spot 10 μ L each of the sample solution and standard solutions (1) and (2) on a plate of silica gel with fluorescent indicator for thin-layer chromatography. Develop the plate with 1-butanol saturated with water to a distance of about 12 cm, and air-dry the

plate. Examine under ultraviolet light (main wavelength: 254 nm): the spots other than the principal spot obtained from the sample solution are not more intense than the spot from the standard solution (1), and the number of them which are more intense than the spot from the standard solution (2) is not more than two. Spray evenly acidic potassium permanganate TS on the plate: any spot other than the principal spot does not appear.

Loss on drying <2.41> Not more than 1.0% (1 g, in vacuum, silica gel, 4 hours).

Residue on ignition <2.44> Not more than 0.5% (1 g).

Assay Weigh accurately about 0.2 g of Cytarabine, previously dried, dissolve in 50 mL of acetic acid (100), and titrate <2.50> with 0.05 mol/L perchloric acid VS (potentiometric titration). Perform a blank determination in the same manner, and make any necessary correction.

$$\begin{aligned} \text{Each mL of 0.05 mol/L perchloric acid VS} \\ = 12.16 \text{ mg of } C_9H_{13}N_3O_5 \end{aligned}$$

Containers and storage Containers—Tight containers.

Danazol

ダナゾール

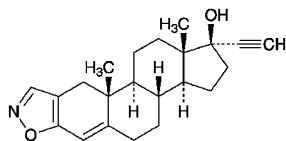

$C_{22}H_{27}NO_2$: 337.46
17 α -Pregna-2,4-dien-20-yno[2,3-*d*]isoxazol-17-ol
[17230-88-5]

Danazol, when dried, contains not less than 98.5% and not more than 101.0% of danazol ($C_{22}H_{27}NO_2$).

Description Danazol occurs as a white to pale yellow crystalline powder.

It is soluble in acetone, sparingly soluble in ethanol (99.5), and practically insoluble in water.

Melting point: about 225°C (with decomposition).

Identification (1) Determine the absorption spectrum of a solution of Danazol in ethanol (95) (1 in 50,000) as directed under Ultraviolet-visible Spectrophotometry <2.24>, and compare the spectrum with the Reference Spectrum or the spectrum of a solution of Danazol RS prepared in the same manner as the sample solution: both spectra exhibit similar intensities of absorption at the same wavelengths.

(2) Determine the infrared absorption spectrum of Danazol as directed in the potassium bromide disk method under Infrared Spectrophotometry <2.25>, and compare the spectrum with the Reference Spectrum or the spectrum of Danazol RS: both spectra exhibit similar intensities of absorption at the same wave numbers.

Optical rotation <2.49> $[\alpha]_D^{20}$: +8 – +11° (after drying, 0.25 g, ethanol (99.5), 50 mL, 100 mm).

Purity (1) Chloride <1.03>—To 2.0 g of Danazol add 80 mL of water, shake well, and boil for 5 minutes. After cooling, add water to make 100 mL, and filter through a glass filter (G4). Discard the first 30 mL of the filtrate, take 40 mL of the subsequent filtrate, and add 6 mL of dilute nitric acid and water to make 50 mL. Perform the test using this solu-

tion as the test solution. Prepare the control solution with 0.25 mL of 0.01 mol/L hydrochloric acid VS (not more than 0.011%).

(2) Heavy metals <1.07>—Proceed with 2.0 g of Danazol according to Method 2, and perform the test. Prepare the control solution with 2.0 mL of Standard Lead Solution (not more than 10 ppm).

(3) Related substances—Dissolve 0.20 g of Danazol in 4 mL of acetone, and use this solution as the sample solution. Pipet 2 mL of the sample solution, add acetone to make exactly 200 mL. Pipet 4 mL of this solution, add acetone to make exactly 20 mL, and use this solution as the standard solution. Perform the test with these solutions as directed under Thin-layer Chromatography <2.03>. Spot 5 μ L each of the sample solution and standard solution on a plate of silica gel with fluorescent indicator for thin-layer chromatography. Develop the plate with a mixture of cyclohexane and ethyl acetate (3:2) to a distance of about 15 cm, and air-dry the plate. Examine under ultraviolet light (main wavelength: 254 nm): the spots other than the principal spot and the spot of the starting point obtained from the sample solution are not more intense than the spot from the standard solution.

Loss on drying <2.41> Not more than 0.2% (1 g, in vacuum, phosphorous (V) oxide, 60°C, 4 hours).

Residue on ignition <2.44> Not more than 0.1% (1 g).

Assay Weigh accurately about 25 mg each of Danazol and Danazol RS, previously dried, dissolve separately in ethanol (95) to make exactly 50 mL. Pipet 2 mL each of these solutions, add ethanol (95) to make exactly 50 mL, and use these solutions as the sample solution and the standard solution, respectively. Perform the test with the sample solution and standard solution as directed under Ultraviolet-visible Spectrophotometry <2.24>, and determine the absorbances, A_T and A_S , at 285 nm.

$$\begin{aligned} \text{Amount (mg) of danazol (} C_{22}H_{27}NO_2 \text{)} \\ = M_S \times A_T/A_S \end{aligned}$$

M_S : Amount (mg) of Danazol RS taken

Containers and storage Containers—Well-closed containers.

Storage—Light-resistant.

Dantrolene Sodium Hydrate

ダントロレンナトリウム水和物

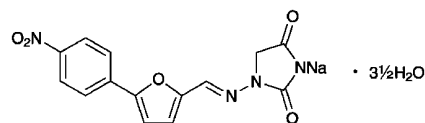

$C_{14}H_9N_4NaO_5 \cdot 3\frac{1}{2}H_2O$: 399.29
Monosodium 3-[5-(4-nitrophenyl)furan-2-ylmethylene]amino-2,5-dioxo-1,3-imidazolidinate hemiheptahydrate
[14663-23-1, anhydride]

Dantrolene Sodium Hydrate contains not less than 98.0% of dantrolene sodium ($C_{14}H_9N_4NaO_5$: 336.23), calculated on the anhydrous basis.

Description Dantrolene Sodium Hydrate occurs as a yellowish orange to deep orange, crystalline powder.

It is soluble in propylene glycol, sparingly soluble in meth-

anol, slightly soluble in ethanol (95), very slightly soluble in water and in acetic acid (100), and practically insoluble in acetone, in tetrahydrofuran and in diethyl ether.

Identification (1) Determine the absorption spectrum of a solution of Dantrolene Sodium Hydrate in methanol (1 in 100,000) as directed under Ultraviolet-visible Spectrophotometry <2.24>, and compare the spectrum with the Reference Spectrum: both spectra exhibit similar intensities of absorption at the same wavelengths.

(2) Determine the infrared absorption spectrum of Dantrolene Sodium Hydrate as directed in the potassium bromide disk method under Infrared Spectrophotometry <2.25>, and compare the spectrum with the Reference Spectrum: both spectra exhibit similar intensities of absorption at the same wave numbers.

(3) To 0.1 g of Dantrolene Sodium Hydrate add 20 mL of water and 2 drops of acetic acid (100), shake well, and filter: the filtrate responds to Qualitative Tests <1.09> (1) for sodium salt.

Purity (1) Alkalinity—To 0.7 g of Dantrolene Sodium Hydrate add 10 mL of water, shake well, and centrifuge or filter through a membrane filter. To 5 mL of the supernatant liquid or the filtrate add 45 mL of water, 3 drops of phenolphthalein TS and 0.10 mL of 0.1 mol/L hydrochloric acid VS: a red color is not produced.

(2) Heavy metals <1.07>—Proceed with 1.0 g of Dantrolene Sodium Hydrate according to Method 2, and perform the test. Prepare the control solution with 2.0 mL of Standard Lead Solution (not more than 20 ppm).

(3) Related Substances—Dissolve 50 mg of Dantrolene Sodium Hydrate in 20 mL of tetrahydrofuran and 2 mL of acetic acid (100), add ethanol (99.5) to make 100 mL, and use this solution as the sample solution. Pipet 1 mL of the sample solution, add ethanol (99.5) to make exactly 50 mL, and use this solution as the standard solution. Perform the test with exactly 10 μ L of the sample solution and standard solution as directed under Liquid Chromatography <2.01> according to the following conditions. Determine each peak area from these solutions by the automatic integration method: the total area of peaks other than dantrolene obtained from the sample solution is not larger than the peak area of dantrolene from the standard solution.

Operating conditions—

Detector: An ultraviolet absorption photometer (wavelength: 300 nm).

Column: A stainless steel column about 4 mm in inside diameter and about 15 cm in length, packed with silica gel for liquid chromatography (5 μ m in particle diameter).

Column temperature: A constant temperature of about 30°C.

Mobile phase: A mixture of hexane, acetic acid (100) and ethanol (99.5) (90:10:9).

Flow rate: Adjust so that the retention time of dantrolene is about 8 minutes.

Selection of column: Dissolve 5 mg of Dantrolene Sodium Hydrate and 0.1 g of theophylline in 20 mL of tetrahydrofuran and 2 mL of acetic acid (100), and add ethanol (99.5) to make 100 mL. To 10 mL of this solution add ethanol (99.5) to make 100 mL. Proceed with 10 μ L of this solution under the above operating conditions, and calculate the resolution. Use a column giving elution of theophylline and dantrolene in this order with the resolution between these peaks being not less than 6.

Detection sensitivity: Adjust so that the peak height of dantrolene from 10 μ L of the standard solution is 10 to 40% of the full scale.

Time span of measurement: About twice as long as the retention time of dantrolene, beginning after the solvent peak.

Water <2.48> 14.5 – 17.0% (0.2 g, volumetric titration, direct titration).

Assay Weigh accurately about 0.7 g of Dantrolene Sodium Hydrate, dissolve in 180 mL of a mixture of propylene glycol and acetone (1:1), and titrate <2.50> with 0.1 mol/L perchloric acid VS (potentiometric titration). Perform a blank determination in the same manner, and make any necessary correction.

Each mL of 0.1 mol/L perchloric acid VS
= 33.62 mg of C₁₄H₉N₄NaO₅

Containers and storage Containers—Tight containers.

Daunorubicin Hydrochloride

ダウノルビシン塩酸塩

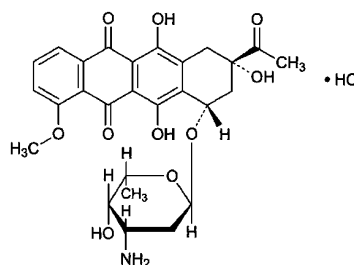

C₂₇H₂₉NO₁₀.HCl: 563.98
(2*S*,4*S*)-2-Acetyl-4-(3-amino-2,3,6-trideoxy- α -L-lyxo-hexopyranosyloxy)-2,5,12-trihydroxy-7-methoxy-1,2,3,4-tetrahydrotetracycline-6,11-dione monohydrochloride
[23541-50-6]

Daunorubicin Hydrochloride is the hydrochloride of an anthracycline substance having antitumor activity produced by the growth of *Streptomyces peucetius* or *Streptomyces coeruleorubidus*.

It contains not less than 940 μ g (potency) and not more than 1050 μ g (potency) per mg, calculated on the dried basis. The potency of Daunorubicin Hydrochloride is expressed as mass (potency) of daunorubicin hydrochloride (C₂₇H₂₉NO₁₀.HCl).

Description Daunorubicin Hydrochloride occurs as a red powder.

It is soluble in water and in methanol, and slightly soluble in ethanol (99.5).

Identification (1) Determine the absorption spectrum of a solution of Daunorubicin Hydrochloride in methanol (1 in 100,000) as directed under Ultraviolet-visible Spectrophotometry <2.24>, and compare the spectrum with the Reference Spectrum or the spectrum of a solution of Daunorubicin Hydrochloride RS prepared in the same manner as the sample solution: both spectra exhibit similar intensities of absorption at the same wavelengths.

(2) Determine the infrared absorption spectrum of Daunorubicin Hydrochloride as directed in the potassium chloride disk method under Infrared Spectrophotometry <2.25>, and compare the spectrum with the Reference Spectrum or the spectrum of Daunorubicin Hydrochloride RS: both spectra exhibit similar intensities of absorption at the

same wave numbers.

(3) A solution of Daunorubicin Hydrochloride (1 in 50) responds to Qualitative Tests <1.09> (2) for chloride.

Optical rotation <2.49> $[\alpha]_D^{20}$: +250 - +275° (15 mg calculated on the dried basis, methanol, 10 mL, 100 mm).

pH <2.54> Dissolve 0.15 g of Daunorubicin Hydrochloride in 30 mL of water: the pH of the solution is between 4.5 and 6.0.

Purity (1) Clarity and color of solution—Dissolve 20 mg of Daunorubicin Hydrochloride in 10 mL of water: the solution is clear and red.

(2) Heavy metals <1.07>—Proceed with 1.0 g of Daunorubicin Hydrochloride according to Method 2, and perform the test. Prepare the control solution with 2.0 mL of Standard Lead Solution (not more than 20 ppm).

(3) Related substances—Weigh accurately about 50 mg of Daunorubicin Hydrochloride, dissolve in diluted acetonitrile (43 in 100) to make exactly 50 mL, and use this solution as the sample solution. Separately, weigh accurately about 50 mg of Daunorubicin Hydrochloride RS, and dissolve in diluted acetonitrile (43 in 100) to make exactly 50 mL. Pipet 1 mL of this solution, add diluted acetonitrile (43 in 100) to make exactly 200 mL, and use this solution as the standard solution (1). Separately, weigh accurately about 5 mg of Doxorubicin Hydrochloride RS, and dissolve in diluted acetonitrile (43 in 100) to make exactly 100 mL. Pipet 1 mL of this solution, add diluted acetonitrile (43 in 100) to make exactly 10 mL, and use this solution as the standard solution (2). Perform the test with exactly 5 μ L each of the sample solution and standard solutions (1) and (2) as directed under Liquid Chromatography <2.01> according to the following conditions. Determine each peak area by the automatic integration method, and calculate the amounts of related substances by the following equations: each amount of each peak, having a relative retention time of about 0.3, about 0.6, about 0.7, about 0.8, about 1.7 and about 2.0 to daunorubicin, is not more than 1.3%, not more than 1.0%, not more than 0.3%, not more than 0.5%, not more than 0.4% and not more than 0.5%, respectively, and the amount of doxorubicin is not more than 0.4%. Furthermore, the total amount of the peaks, other than daunorubicin and the peaks mentioned above, is not more than 0.4%. For the area of the peak, having a relative retention time of about 0.3 to daunorubicin, multiply the correction factor, 0.7.

Each amount (%) of related substances other than doxorubicin

$$= M_{S1}/M_T \times A_T/A_{S1} \times 1/2$$

M_{S1} : Amount (mg) of Daunorubicin Hydrochloride RS taken

M_T : Amount (mg) of Daunorubicin Hydrochloride taken

A_{S1} : Peak area of daunorubicin obtained from the standard solution (1)

A_T : Peak area of each related substance obtained from the sample solution

$$\text{Amount (\%)} \text{ of doxorubicin} = M_{S2}/M_T \times A_T/A_{S2} \times 5$$

M_{S2} : Amount (mg) of Doxorubicin Hydrochloride RS taken

M_T : Amount (mg) of Daunorubicin Hydrochloride taken

A_{S2} : Peak area of doxorubicin obtained from the standard solution (2)

A_T : Peak area of doxorubicin obtained from the sample solution

Operating conditions—

Detector: An ultraviolet absorption photometer (wavelength: 254 nm).

Column: A stainless steel column 4.6 mm in inside diameter and 25 cm in length, packed with octadecylsilanized silica gel for liquid chromatography (5 μ m in particle diameter).

Column temperature: A constant temperature of about 25°C.

Mobile phase: Dissolve 2.88 g of sodium lauryl sulfate and 2.25 g of phosphoric acid in water to make 1000 mL. To 570 mL of this solution add 430 mL of acetonitrile.

Flow rate: Adjust so that the retention time of daunorubicin is about 26 minutes.

Time span of measurement: About 2 times as long as the retention time of daunorubicin.

System suitability—

Test for required detectability: To exactly 1 mL of the standard solution (1) add diluted acetonitrile (43 in 100) to make exactly 10 mL. Confirm that the peak area of daunorubicin obtained with 5 μ L of this solution is equivalent to 7 to 13% of that with 5 μ L of the standard solution (1).

System performance: Dissolve 5 mg each of Daunorubicin Hydrochloride and doxorubicin hydrochloride in 25 mL of diluted acetonitrile (43 in 100). To 1 mL of this solution add diluted acetonitrile (43 in 100) to make 10 mL. When the procedure is run with 5 μ L of this solution under the above operating conditions, doxorubicin and daunorubicin are eluted in this order with the resolution between these peaks being not less than 13.

System repeatability: When the test is repeated 6 times with 5 μ L of the standard solution (1) under the above operating conditions, the relative standard deviation of the peak area of daunorubicin is not more than 3.0%.

Loss on drying <2.41> Not more than 7.5% (0.1 g, reduced pressure not exceeding 0.67 kPa, 60°C, 3 hours).

Assay Weigh accurately an amount of Daunorubicin Hydrochloride and Daunorubicin Hydrochloride RS, equivalent to about 20 mg (potency), dissolve each in a suitable amount of the mobile phase, add exactly 4 mL of the internal standard solution and the mobile phase to make 20 mL, and use these solutions as the sample solution and the standard solution, respectively. Perform the test with 5 μ L each of the sample solution and standard solution as directed under Liquid Chromatography <2.01> according to the following conditions, and calculate the ratios, Q_T and Q_S , of the peak area of daunorubicin to that of the internal standard.

$$\begin{aligned} &\text{Amount } [\mu\text{g (potency)}] \text{ of daunorubicin hydrochloride} \\ &(\text{C}_{27}\text{H}_{29}\text{NO}_{10}\cdot\text{HCl}) \\ &= M_S \times Q_T/Q_S \times 1000 \end{aligned}$$

M_S : Amount [mg (potency)] of Daunorubicin Hydrochloride RS taken

Internal standard solution—A solution of 2-naphthalenesulfonic acid in the mobile phase (1 in 100).

Operating conditions—

Detector: An ultraviolet absorption photometer (wavelength: 254 nm).

Column: A stainless steel column 4.6 mm in inside diameter and 30 cm in length, packed with octadecylsilanized silica gel for liquid chromatography (10 μ m in particle diameter).

Column temperature: A constant temperature of about 25°C.

Mobile phase: Adjust the pH of a mixture of water and

acetonitrile (31:19) to 2.2 with phosphoric acid.

Flow rate: Adjust so that the retention time of daunorubicin is about 9 minutes.

System suitability—

System performance: When the procedure is run with 5 μ L of the standard solution under the above operating conditions, the internal standard and daunorubicin are eluted in this order with the resolution between these peaks being not less than 2.0.

System repeatability: When the test is repeated 6 times with 5 μ L of the standard solution under the above operating conditions, the relative standard deviation of the ratios of the peak area of daunorubicin to that of the internal standard is not more than 2.0%.

Containers and storage Containers—Tight containers.

Deferoxamine Mesilate

デフェロキサミンメシル酸塩

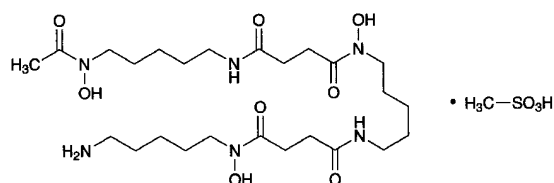

$C_{25}H_{48}N_6O_8 \cdot CH_4O_3S$; 656.79

N-[5-(Acetylhydroxyamino)pentyl]-*N'*-(5-[3-[(5-aminopentyl)hydroxycarbonyl]propanoylamino]pentyl)-*N'*-hydroxysuccinamide monomethanesulfonate [138-14-7]

Deferoxamine Mesilate contains not less than 98.0% and not more than 102.0% of deferoxamine mesilate ($C_{25}H_{48}N_6O_8 \cdot CH_4O_3S$), calculated on the anhydrous basis.

Description Deferoxamine Mesilate occurs as a white to pale yellow-white crystalline powder.

It is freely soluble in water, and practically insoluble in ethanol (99.5), in 2-propanol and in diethyl ether.

Melting point: about 147°C (with decomposition).

Identification (1) To 5 mL of a solution of Deferoxamine Mesilate (1 in 500) add 1 drop of iron (III) chloride TS: a deep red color develops.

(2) A 50 mg portion of Deferoxamine Mesilate responds to Qualitative Tests <1.09> (1) for mesilate.

(3) Determine the infrared absorption spectrum of Deferoxamine Mesilate as directed in the potassium bromide disk method under Infrared Spectrophotometry <2.25>, and compare the spectrum with the Reference Spectrum or the spectrum of Deferoxamine Mesilate RS: both spectra exhibit similar intensities of absorption at the same wave numbers.

pH <2.54> Dissolve 1.0 g of Deferoxamine Mesilate in 10 mL of water: the pH of this solution is between 3.5 and 5.5.

Purity (1) Clarity and color of solution—Dissolve 1.0 g of Deferoxamine Mesilate in 10 mL of water: the solution is clear and colorless to pale yellow.

(2) Chloride <1.03>—Perform the test with 1.0 g of Deferoxamine Mesilate. Prepare the control solution with 0.90 mL of 0.01 mol/L hydrochloric acid VS (not more than 0.032%).

(3) Sulfate <1.14>—Perform the test with 0.6 g of

Deferoxamine Mesilate. Prepare the control solution with 0.50 mL of 0.005 mol/L sulfuric acid VS (not more than 0.040%).

(4) Heavy metals <1.07>—Proceed with 2.0 g of Deferoxamine Mesilate according to Method 4, and perform the test. Prepare the control solution with 2.0 mL of Standard Lead Solution (not more than 10 ppm).

(5) Arsenic <1.11>—Prepare the test solution with 1.0 g of Deferoxamine Mesilate according to Method 3, and perform the test. Use a solution of magnesium nitrate hexahydrate in ethanol (95) (1 in 10) (not more than 2 ppm).

(6) Related substances—Dissolve 50 mg of Deferoxamine Mesilate in 50 mL of the mobile phase, and use this solution as the sample solution. Pipet 3 mL of the sample solution, add the mobile phase to make exactly 50 mL, and use this solution as the standard solution. Perform the test with exactly 20 μ L each of the sample solution and standard solution as directed under Liquid Chromatography <2.01> according to the following conditions. Determine each peak area of both solutions by the automatic integration method: the total area of peaks other than deferoxamine obtained from the sample solution is not larger than the peak area of deferoxamine from the standard solution.

Operating conditions—

Detector: An ultraviolet absorption photometer (wavelength: 230 nm).

Column: A stainless steel column 4 mm in inside diameter and 20 cm in length, packed with octadecylsilylated silica gel for liquid chromatography (10 μ m in particle diameter).

Column temperature: A constant temperature of about 40°C.

Mobile phase: Dissolve 1.32 g of diammonium hydrogen phosphate, 0.37 g of disodium dihydrogen ethylenediamine tetraacetate dihydrate and 1.08 g of sodium 1-heptanesulfonate in 950 mL of water, and adjust the pH of this solution to 2.8 with phosphoric acid. To 800 mL of this solution add 100 mL of 2-propanol.

Flow rate: Adjust so that the retention time of deferoxamine is about 15 minutes.

Time span of measurement: About two times as long as the retention time of deferoxamine, beginning after the solvent peak.

System suitability—

Test for required detectability: To exactly 2 mL of the standard solution add the mobile phase to make exactly 100 mL. Confirm that the peak area of deferoxamine obtained with 20 μ L of this solution is equivalent to 1.5 to 2.5% of that with 20 μ L of the standard solution.

System performance: Dissolve 16 mg of Deferoxamine Mesilate and 4 mg of methyl parahydroxybenzoate in 50 mL of the mobile phase. When the procedure is run with 20 μ L of this solution under the above operating conditions, deferoxamine and methyl parahydroxybenzoate are eluted in this order with the resolution between these peaks being not less than 4.

System repeatability: When the test is repeated 6 times with 20 μ L of the standard solution under the above operating conditions, the relative standard deviation of the peak areas of deferoxamine is not more than 3.0%.

Water <2.48> Not more than 2.0% (0.2 g, volumetric titration, direct titration).

Residue on ignition <2.44> Not more than 0.1% (1 g).

Assay Weigh accurately about 60 mg of Deferoxamine Mesilate and Deferoxamine Mesilate RS (previously determine the water <2.48> in the same manner as Deferoxamine

Mesilate), dissolve each in 20 mL of water, add exactly 10 mL of 0.05 mol/L sulfuric acid TS, and add water to make exactly 50 mL. Pipet 5 mL each of these solutions, add exactly 5 mL of 0.05 mol/L sulfuric acid TS and exactly 0.2 mL of iron (III) chloride TS, then add water to make exactly 50 mL, and use these solutions as the sample solution and the standard solution, respectively. Perform the test with these solutions as directed under Ultraviolet-visible Spectrophotometry <2.24>, using a solution prepared by adding 0.05 mol/L sulfuric acid TS to 0.2 mL of iron (III) chloride TS to make exactly 50 mL as the blank, and determine the absorbances, A_T and A_S , of each solution from the sample solution and the standard solution at 430 nm.

$$\begin{aligned} & \text{Amount (mg) of deferoxamine mesilate} \\ & (\text{C}_{25}\text{H}_{48}\text{N}_6\text{O}_8 \cdot \text{CH}_3\text{O}_3\text{S}) \\ & = M_S \times A_T / A_S \end{aligned}$$

M_S : Amount (mg) of Deferoxamine Mesilate RS taken, calculated on the anhydrous basis

Containers and storage Containers—Tight containers.

Dehydrocholic Acid

デヒドロコール酸

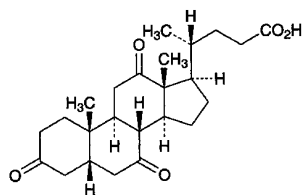

$\text{C}_{24}\text{H}_{34}\text{O}_5$: 402.52

3,7,12-Trioxo-5 β -cholan-24-oic acid
[81-23-2]

Dehydrocholic Acid, when dried, contains not less than 98.5% of dehydrocholic acid ($\text{C}_{24}\text{H}_{34}\text{O}_5$).

Description Dehydrocholic Acid occurs as a white crystalline powder. It is odorless, and has a bitter taste.

It is sparingly soluble in acetone, slightly soluble in ethanol (95), and practically insoluble in water.

It dissolves in sodium hydroxide TS.

Identification (1) Dissolve 5 mg of Dehydrocholic Acid in 1 mL of sulfuric acid and 1 drop of formaldehyde solution, and allow to stand for 5 minutes. Add 5 mL of water to the solution: the solution shows a yellow color and a blue-green fluorescence.

(2) To 0.02 g of Dehydrocholic Acid add 1 mL of ethanol (95), shake, add 5 drops of 1,3-dinitrobenzene TS and 0.5 mL of a solution of sodium hydroxide (1 in 8), and allow to stand: a purple to red-purple color develops, and gradually changes to brown.

Optical rotation <2.49> $[\alpha]_D^{25}$: +20 – +26° (after drying, 0.2 g, acetone, 10 mL, 100 mm).

Melting point <2.60> 233 – 242°C

Purity (1) Odor—To 2.0 g of Dehydrocholic Acid add 100 mL of water, and boil for 2 minutes: the solution is odorless.

(2) Clarity and color of solution—To 0.10 g of Dehydrocholic Acid, previously powdered in a mortar, add 30 mL of ethanol (95), and dissolve by shaking for 10 minutes: the so-

lution is clear and colorless.

(3) Chloride <1.03>—To 2.0 g of Dehydrocholic Acid add 100 mL of water, shake for 5 minutes and filter, and use this filtrate as the sample solution. To 25 mL of the sample solution add 6 mL of dilute nitric acid, heat in a water bath for 6 minutes, filter after cooling, and collect the clear filtrate. Wash the residue with 10 mL of water, combine the washings and the filtrate, dilute with water to 50 mL, and perform the test using this solution as the test solution. Prepare the control solution with 0.30 mL of 0.01 mol/L hydrochloric acid VS (not more than 0.021%).

(4) Sulfate <1.14>—Add 1 mL of dilute hydrochloric acid to 25 mL of the sample solution obtained in (3), heat in a water bath for 6 minutes, filter after cooling, and collect the clear filtrate. Wash the residue with 10 mL of water, combine the washings and the filtrate, dilute with water to 50 mL, and perform the test using this solution as the test solution. Prepare the control solution with 0.50 mL of 0.005 mol/L sulfuric acid VS (not more than 0.048%).

(5) Heavy metals <1.07>—Proceed with 1.0 g of Dehydrocholic Acid according to Method 2, and perform the test. Prepare the control solution with 2.0 mL of Standard Lead Solution (not more than 20 ppm).

(6) Barium—To the solution obtained in (1) add 2 mL of hydrochloric acid, and boil for 2 minutes. Cool, filter, and wash with water until 100 mL of the filtrate is obtained. To 10 mL of the filtrate add 1 mL of dilute sulfuric acid: no turbidity is produced.

Loss on drying <2.41> Not more than 1.0% (1 g, 105°C, 2 hours).

Residue on ignition <2.44> Not more than 0.2% (1 g).

Assay Weigh accurately about 0.5 g of Dehydrocholic Acid, previously dried, add 40 mL of neutralized ethanol and 20 mL of water, and dissolve by warming. Add 2 drops of phenolphthalein TS, titrate <2.50> with 0.1 mol/L sodium hydroxide VS, adding 100 mL of freshly boiled and cooled water as the end point is approached, and continue the titration.

Each mL of 0.1 mol/L sodium hydroxide VS
= 40.25 mg of $\text{C}_{24}\text{H}_{34}\text{O}_5$

Containers and storage Containers—Well-closed containers.

Purified Dehydrocholic Acid

精製デヒドロコール酸

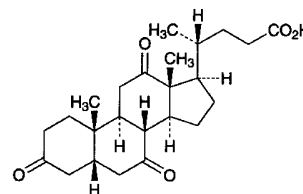

$\text{C}_{24}\text{H}_{34}\text{O}_5$: 402.52

3,7,12-Trioxo-5 β -cholan-24-oic acid
[81-23-2]

Purified Dehydrocholic Acid, when dried, contains not less than 99.0% of dehydrocholic acid ($\text{C}_{24}\text{H}_{34}\text{O}_5$).

Description Purified Dehydrocholic Acid occurs as a white crystalline powder. It is odorless, and has a bitter taste.

It is sparingly soluble in acetone, slightly soluble in ethanol (95), and practically insoluble in water.

It dissolves in sodium hydroxide TS.

Identification (1) Dissolve 5 mg of Purified Dehydrocholic Acid in 1 mL of sulfuric acid and 1 drop of formaldehyde solution, and allow to stand for 5 minutes. Add 5 mL of water to the solution: the solution shows a yellow color and blue-green fluorescence.

(2) To 0.02 g of Purified Dehydrocholic Acid add 1 mL of ethanol (95), shake, add 5 drops of 1,3-dinitrobenzene TS and 0.5 mL of a solution of sodium hydroxide (1 in 8), and allow to stand: a purple to red-purple color develops, and gradually changes to brown.

Optical rotation <2.49> $[\alpha]_D^{25}$: +20 - +26° (after drying, 0.2 g, acetone, 10 mL, 100 mm).

Melting point <2.60> 237 - 242°C

Purity (1) Odor—To 2.0 g of Purified Dehydrocholic Acid add 100 mL of water, and boil for 2 minutes: the solution is odorless.

(2) Clarity and color of solution—Dissolve 0.10 g of Purified Dehydrocholic Acid, previously powdered in a mortar, in 30 mL of ethanol (95) by shaking for 10 minutes: the solution is clear and colorless.

(3) Chloride <1.03>—To 2.0 g of Purified Dehydrocholic Acid add 100 mL of water, shake for 5 minutes and filter, and use this filtrate as the sample solution. To 25 mL of the sample solution add 6 mL of dilute nitric acid, heat in a water bath for 6 minutes, filter after cooling, and collect the clear filtrate. Wash the residue with 10 mL of water, combine the washings and the filtrate, dilute with water to 50 mL, and perform the test using this solution as the test solution. Prepare the control solution with 0.30 mL of 0.01 mol/L hydrochloric acid VS (not more than 0.021%).

(4) Sulfate <1.14>—Add 1 mL of dilute hydrochloric acid to 25 mL of the sample solution obtained in (3), heat in a water bath for 6 minutes, filter after cooling, and collect the clear filtrate. Wash the residue with 10 mL of water, combine the washings and the filtrate, dilute with water to 50 mL, and perform the test using this solution as the test solution. Prepare the control solution with 0.50 mL of 0.005 mol/L sulfuric acid VS (not more than 0.048%).

(5) Heavy metals <1.07>—Proceed with 1.0 g of Purified Dehydrocholic Acid according to Method 2, and perform the test. Prepare the control solution with 2.0 mL of Standard Lead Solution (not more than 20 ppm).

(6) Barium—To the solution obtained in (1) add 2 mL of hydrochloric acid, and boil for 2 minutes, cool, filter, and wash the filter with water until 100 mL of the filtrate is obtained. To 10 mL of the filtrate add 1 mL of dilute sulfuric acid: no turbidity is produced.

Loss on drying <2.41> Not more than 1.0% (1 g, 105°C, 2 hours).

Residue on ignition <2.44> Not more than 0.2% (1 g).

Assay Weigh accurately about 0.5 g of Purified Dehydrocholic Acid, previously dried, add 40 mL of neutralized ethanol and 20 mL of water, and dissolve by warming. Add 2 drops of phenolphthalein TS, then titrate <2.50> with 0.1 mol/L sodium hydroxide VS, adding 100 mL of freshly boiled and cooled water as the end point is approached, and continue the titration.

Each mL of 0.1 mol/L sodium hydroxide VS
= 40.25 mg of $C_{24}H_{34}O_5$

Containers and storage Containers—Well-closed containers.

Dehydrocholic Acid Injection

デヒドロコール酸注射液

Dehydrocholic Acid Injection is an aqueous injection.

It contains not less than 95.0% and not more than 105.0% of the labeled amount of dehydrocholic acid ($C_{24}H_{34}O_5$; 402.52).

Method of preparation Dissolve Purified Dehydrocholic Acid in a solution of Sodium Hydroxide, and prepare as directed under Injections.

Description Dehydrocholic Acid Injection is a clear, colorless to light yellow liquid, and has a bitter taste.

pH: 9 - 11

Identification Transfer a volume of Dehydrocholic Acid Injection, equivalent to 0.1 g of Purified Dehydrocholic Acid, to a separator, and add 10 mL of water and 1 mL of dilute hydrochloric acid: a white precipitate is produced. Extract the mixture with three 15-mL portions of chloroform, combine all the chloroform extracts, evaporate the chloroform on a water bath, and dry the residue at 105°C for 1 hour: the residue so obtained melts <2.60> between 235°C and 242°C.

Purity Heavy metals <1.07>—Evaporate a volume of Dehydrocholic Acid Injection, equivalent to 1.0 g of Purified Dehydrocholic Acid, on a water bath to dryness. Proceed with the residue according to Method 2, and perform the test. Prepare the control solution with 2.0 mL of Standard Lead Solution (not more than 20 ppm).

Bacterial endotoxins <4.01> Less than 0.30 EU/mg.

Extractable volume <6.05> It meets the requirement.

Foreign insoluble matter <6.06> Perform the test according to Method 1: it meets the requirement.

Insoluble particulate matter <6.07> It meets the requirement.

Sterility <4.06> Perform the test according to the Membrane filtration method: it meets the requirement.

Assay Transfer an exactly measured volume of Dehydrocholic Acid Injection, equivalent to about 0.5 g of dehydrocholic acid ($C_{24}H_{34}O_5$), to a 100-mL separator, and add, if necessary, water to make 25 mL. Add 2 mL of hydrochloric acid, and extract with 25-mL, 20-mL and 15-mL portions of chloroform successively. Combine the chloroform extracts, wash with cold water until the washings become negative to acid, and evaporate the chloroform on a water bath. Dissolve the residue in 40 mL of neutralized ethanol and 20 mL of water by warming. Add 2 drops of phenolphthalein TS to this solution, titrate <2.50> with 0.1 mol/L sodium hydroxide VS, adding 100 mL of freshly boiled and cooled water as the end point is approached, and continue the titration.

Each mL of 0.1 mol/L sodium hydroxide VS
= 40.25 mg of $C_{24}H_{34}O_5$

Containers and storage Containers—Hermetic containers, and colored containers may be used.

Storage—Light-resistant.

Demethylchlortetracycline Hydrochloride

デメチルクロルテトラサイクリン塩酸塩

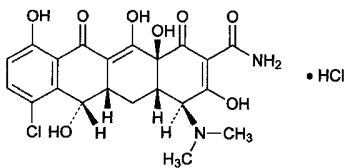

$C_{21}H_{21}ClN_2O_8 \cdot HCl$: 501.31
 (4*S*,4*aS*,5*aS*,6*S*,12*aS*)-7-Chloro-4-dimethylamino-3,6,10,12,12*a*-pentahydroxy-1,11-dioxo-1,4,4*a*,5,5*a*,6,11,12*a*-octahydrotetracycline-2-carboxamide monohydrochloride
 [64-73-3]

Demethylchlortetracycline Hydrochloride is the hydrochloride of a tetracycline substance having antibacterial activity produced by the growth of the mutant of *Streptomyces aureofaciens*.

It contains not less than 900 μg (potency) and not more than 1010 μg (potency) per mg, calculated on the dried basis. The potency of Demethylchlortetracycline Hydrochloride is expressed as mass (potency) of demethylchlortetracycline hydrochloride ($C_{21}H_{21}ClN_2O_8 \cdot HCl$).

Description Demethylchlortetracycline Hydrochloride occurs as a yellow crystalline powder.

It is soluble in water, and slightly soluble in ethanol (99.5).

Identification (1) Dissolve 40 mg of Demethylchlortetracycline Hydrochloride in 250 mL of water. To 10 mL of this solution add 85 mL of water and 5 mL of a solution of sodium hydroxide (1 in 5). Determine the absorption spectrum of this solution as directed under Ultraviolet-visible Spectrophotometry <2.24>, and compare the spectrum with the Reference Spectrum or the spectrum of a solution of Demethylchlortetracycline Hydrochloride RS prepared in the same manner as the sample solution: both spectra exhibit similar intensities of absorption at the same wavelengths.

(2) Determine the infrared absorption spectrum of Demethylchlortetracycline Hydrochloride as directed in the potassium chloride disk method under Infrared Spectrophotometry <2.25>, and compare the spectrum with the Reference Spectrum or the spectrum of Demethylchlortetracycline Hydrochloride RS: both spectra exhibit similar intensities of absorption at the same wave numbers.

(3) A solution of Demethylchlortetracycline Hydrochloride (1 in 100) responds to Qualitative Tests <1.09> (2) for chloride.

Optical rotation <2.49> $[\alpha]_D^{20}$: $-248 - -263^\circ$ (0.25 g calculated on the dried basis, 0.1 mol/L hydrochloric acid TS, 25 mL, 100 mm).

pH <2.54> Dissolve 1.0 g of Demethylchlortetracycline Hydrochloride in 100 mL of water: the pH of the solution is between 2.0 and 3.0.

Purity (1) Heavy metals <1.07>—Proceed with 1.0 g of Demethylchlortetracycline Hydrochloride according to Method 2, and perform the test. Prepare the control solution with 2.0 mL of Standard Lead Solution (not more than 20 ppm).

(2) Related substances—Dissolve 25 mg of Demethylchlortetracycline Hydrochloride in 50 mL of 0.01 mol/L hydrochloric acid TS, and use this solution as the sample solution. Pipet 5 mL of the sample solution, add 0.01 mol/L hydrochloric acid TS to make exactly 100 mL, and use this solution as the standard solution. Perform the test with exactly 20 μL each of the sample solution and standard solution as directed under Liquid Chromatography <2.01> according to the following conditions. Determine each peak area by the automatic integration method: the area of the peak other than demethylchlortetracycline obtained from the sample solution is not larger than 1.2 times the peak area of demethylchlortetracycline from the standard solution, and the total area of the peaks other than demethylchlortetracycline from the sample solution is not larger than 2 times the peak area of demethylchlortetracycline from the standard solution.

Operating conditions—

Detector, column, column temperature, mobile phase, and flow rate: Proceed as directed in the operating conditions in the Assay.

Time span of measurement: About 2 times as long as the retention time of demethylchlortetracycline, beginning after the solvent peak.

System suitability—

System performance: Proceed as directed in the system suitability in the Assay.

Test for required detectability: To 10 mL of the standard solution add 0.01 mol/L hydrochloric acid TS to make 50 mL, and use this solution as the solution for system suitability test. Pipet 5 mL of the solution for system suitability test, and add 0.01 mol/L hydrochloric acid TS to make exactly 50 mL. Confirm that the peak area of demethylchlortetracycline obtained with 20 μL of this solution is equivalent to 7 to 13% of that with 20 μL of the solution for system suitability test.

System repeatability: When the test is repeated 6 times with 20 μL of the standard solution under the above operating conditions, the relative standard deviation of the peak area of demethylchlortetracycline is not more than 1.0%.

Loss on drying <2.41> Not more than 2.0% (1 g, in vacuum, 60°C, 3 hours).

Residue on ignition <2.44> Not more than 0.2% (1 g).

Assay Weigh accurately an amount of Demethylchlortetracycline Hydrochloride and Demethylchlortetracycline Hydrochloride RS, equivalent to about 25 mg (potency), dissolve each in 0.01 mol/L hydrochloric acid TS to make exactly 50 mL, and use these solutions as the sample solution and the standard solution, respectively. Perform the test with exactly 20 μL each of the sample solution and standard solution as directed under Liquid Chromatography <2.01> according to the following conditions, and determine the peak areas, A_T and A_S , of demethylchlortetracycline in each solution.

$$\begin{aligned} &\text{Amount } [\mu\text{g (potency)}] \text{ of demethylchlortetracycline} \\ &\text{hydrochloride } (C_{21}H_{21}ClN_2O_8 \cdot HCl) \\ &= M_S \times A_T / A_S \times 1000 \end{aligned}$$

M_S : Amount [mg (potency)] of Demethylchlortetracycline Hydrochloride RS taken

Operating conditions—

Detector: An ultraviolet absorption photometer (wavelength: 254 nm).

Column: A stainless steel column 4.1 mm in inside diameter and 25 cm in length, packed with styrene-divinylbenzene

copolymer for liquid chromatography (10 μm in particle diameter).

Column temperature: A constant temperature of about 60°C.

Mobile phase: Dissolve 3.5 g of dipotassium hydrogen phosphate, 1.5 g of tetrabutylammonium hydrogensulfate and 0.4 g of disodium dihydrogen ethylenediamine tetraacetate dihydrate in 300 mL of water, and adjust the pH to 8.5 with sodium hydroxide TS. To this solution add 75.0 g of *t*-butanol and water to make 1000 mL.

Flow rate: Adjust so that the retention time of demethylchlortetracycline is about 8 minutes.

System suitability—

System performance: Heat 10 mL of the standard solution on a water bath for 60 minutes. When the procedure is run with 20 μL of this solution so obtained under the above operating conditions, 4-epidemethylchlortetracycline and demethylchlortetracycline are eluted in this order with the resolution between these peaks being not less than 3. The relative retention time of 4-epidemethylchlortetracycline to demethylchlortetracycline is about 0.7.

System repeatability: When the test is repeated 6 times with 20 μL of the standard solution under the above operating conditions, the relative standard deviation of the peak area of demethylchlortetracycline is not more than 1.0%.

Containers and storage Containers—Tight containers.

Storage—Light-resistant.

Deslanoside

デスラノシド

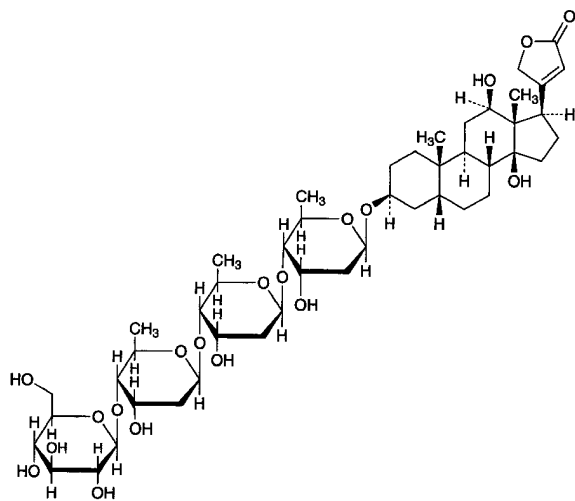

$\text{C}_{47}\text{H}_{74}\text{O}_{19}$: 943.08

3 β -[β -D-Glucopyranosyl-(1 \rightarrow 4)-2,6-dideoxy- β -D-ribo-hexopyranosyl-(1 \rightarrow 4)-2,6-dideoxy- β -D-ribo-hexopyranosyl-(1 \rightarrow 4)-2,6-dideoxy- β -D-ribo-hexopyranosyloxy]-12 β ,14-dihydroxy-5 β ,14 β -card-20(22)-enolide

[17598-65-1]

Deslanoside, when dried, contains not less than 90.0% and not more than 102.0% of deslanoside ($\text{C}_{47}\text{H}_{74}\text{O}_{19}$).

Description Deslanoside occurs as colorless or white crystals or a white, crystalline powder. It is odorless.

It is freely soluble in dehydrated pyridine, sparingly soluble in methanol, slightly soluble in ethanol (95), and practi-

cally insoluble in water and in diethyl ether.

It is hygroscopic.

Identification Transfer 1 mg of Deslanoside to a small test tube about 10 mm in inside diameter, dissolve in 1 mL of a solution of iron (III) chloride hexahydrate in acetic acid (100) (1 in 1000), and underlay gently with 1 mL of sulfuric acid: at the zone of contact of two liquids a brown ring is produced, and the color of the upper layer near to the contact zone changes gradually to blue through purple, and the entire acetic acid layer shows a blue-green color through a deep blue color.

Purity (1) Clarity and color of solution—Dissolve 20 mg of Deslanoside in 10 mL of ethanol (95) and 3 mL of water by warming, cool, and dilute to 100 mL with water: the solution is clear and colorless.

(2) Related substances—Dissolve 10 mg of Deslanoside in exactly 5 mL of methanol, and use this solution as the sample solution. Dissolve 1.0 mg of Deslanoside RS in exactly 5 mL of methanol, and use this solution as the standard solution. Perform the test with these solutions as directed under Thin-layer Chromatography <2.03>. Spot 20 μL each of the sample solution and standard solution on a plate of silica gel for thin-layer chromatography. Develop the plate with a mixture of dichloromethane, methanol and water (84:15:1) to a distance of about 13 cm, and air-dry the plate. Spray evenly dilute sulfuric acid on the plate, and heat the plate at 110°C for 10 minutes: the spots other than the principal spot obtained from the sample solution are not larger and not more intense than the spot from the standard solution.

Optical rotation <2.49> $[\alpha]_D^{20}$: +6.5 – +8.5° (after drying, 0.5 g, dehydrated pyridine, 25 mL, 100 mm).

Loss on drying <2.41> Not more than 8.0% (0.5 g, in vacuum, phosphorus (V) oxide, 60°C, 4 hours).

Residue on ignition <2.44> Not more than 0.5% (0.1 g).

Assay Dissolve about 12 mg each of Deslanoside and Deslanoside RS, previously dried and accurately weighed, in 20 mL each of methanol, add water to make exactly 100 mL, and use these solutions as the sample solution and the standard solution, respectively. Pipet 5 mL each of these solutions, transfer to light-resistant, 25-mL volumetric flasks, shake well with 5 mL each of 2,4,6-trinitrophenol TS and 0.5 mL each of a solution of sodium hydroxide (1 in 10), add diluted methanol (1 in 4) to make 25 mL, and allow to stand at a temperature between 18°C and 22°C for 25 minutes. Determine the absorbances, A_T and A_S , of the subsequent solutions of the sample solution and the standard solution, respectively, at 485 nm as directed under Ultraviolet-visible Spectrophotometry <2.24>, using a solution prepared with 5 mL of diluted methanol (1 in 5) in the same manner as the blank.

Amount (mg) of deslanoside ($\text{C}_{47}\text{H}_{74}\text{O}_{19}$) = $M_S \times A_T/A_S$

M_S : Amount (mg) of Deslanoside RS taken

Containers and storage Containers—Tight containers.

Deslanoside Injection

デスラノシド注射液

Deslanoside Injection is an aqueous injection.

It contains not less than 90.0% and not more than 110.0% of the labeled amount of deslanoside ($C_{47}H_{74}O_{19}$; 943.08).

Method of preparation Dissolve Deslanoside in 10 vol% ethanol and prepare as directed under Injections. It may contain Glycerin. It may be prepared with a suitable amount of Ethanol and Water for Injection or Sterile Water for Injection in Containers.

Description Deslanoside Injection is a clear and colorless liquid.

pH: 5.0 – 7.0

Identification (1) Place a volume of Deslanoside Injection, equivalent to 2 mg of Deslanoside, in a separator, add sodium chloride in the ratio of 0.2 g to each mL of this solution, and extract with three 10-mL portions of chloroform. Combine the chloroform extracts, mix uniformly, pipet 15 mL of this solution, and evaporate the chloroform under reduced pressure. Proceed with the residue as directed in the Identification under Deslanoside.

(2) Evaporate the remaining chloroform extract obtained in (1) under reduced pressure, dissolve the residue in 5 mL of methanol, and use this solution as the sample solution. Separately, dissolve 1 mg of Deslanoside RS in 5 mL of methanol, and use this solution as the standard solution. Perform the test with these solutions as directed under Thin-layer Chromatography <2.03>. Spot 20 μ L each of these solutions on a plate of silica gel for thin-layer chromatography. Develop the plate with a mixture of dichloromethane, methanol and water (84:15:1) to a distance of about 13 cm, and air-dry the plate. Spray evenly dilute sulfuric acid upon the plate, and heat the plate at 110°C for 10 minutes: the spots from the sample solution and standard solution show a black color and have the same Rf value.

Bacterial endotoxins <4.01> Less than 500 EU/mg.

Extractable volume <6.05> It meets the requirement.

Foreign insoluble matter <6.06> Perform the test according to Method 1: it meets the requirement.

Insoluble particulate matter <6.07> It meets the requirement.

Sterility <4.06> Perform the test according to the Membrane filtration method: it meets the requirement.

Assay Measure exactly a volume of Deslanoside Injection, equivalent to about 3 mg of deslanoside ($C_{47}H_{74}O_{19}$). Add 5 mL of methanol and water to make exactly 25 mL. Use this solution as the sample solution, and proceed as directed in the Assay under Deslanoside.

$$\begin{aligned} \text{Amount (mg) of deslanoside (C}_{47}\text{H}_{74}\text{O}_{19}) \\ = M_S \times A_T/A_S \times 1/4 \end{aligned}$$

M_S : Amount (mg) of Deslanoside RS taken

Containers and storage Containers—Hermetic containers.
Storage—Light-resistant.

Dexamethasone

デキサメタゾン

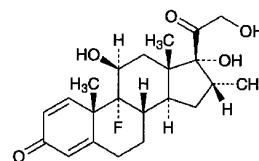

$C_{22}H_{29}FO_5$; 392.46

9-Fluoro-11 β ,17,21-trihydroxy-16 α -methylpregna-1,4-diene-3,20-dione
[50-02-2]

Dexamethasone, when dried, contains not less than 97.0% and not more than 102.0% of dexamethasone ($C_{22}H_{29}FO_5$).

Description Dexamethasone occurs as white to pale yellow, crystals or crystalline powder.

It is sparingly soluble in methanol, in ethanol (95) and in acetone, slightly soluble in acetonitrile, and practically insoluble in water.

Melting point: about 245°C (with decomposition).

It shows crystal polymorphism.

Identification (1) Proceed with 10 mg of Dexamethasone as directed under Oxygen Flask Combustion Method <1.06>, using a mixture of 0.5 mL of 0.01 mol/L sodium hydroxide TS and 20 mL of water as the absorbing liquid: the solution obtained responds to Qualitative Tests <1.09> for fluoride.

(2) Dissolve 1 mg of Dexamethasone in 10 mL of ethanol (95). Mix 2 mL of the solution with 10 mL of phenylhydrazinium chloride TS, heat in a water bath at 60°C for 20 minutes, and cool the solution. Determine the absorption spectrum of the solution as directed under Ultraviolet-visible Spectrophotometry <2.24>, using as the blank the solution prepared with 2 mL of ethanol (95) in the same manner as the former solution, and compare the spectrum with the Reference Spectrum or the spectrum of a solution of Dexamethasone RS prepared in the same manner as the former solution: both spectra exhibit similar intensities of absorption at the same wavelengths.

(3) Determine the infrared absorption spectrum of Dexamethasone, previously dried, as directed in the potassium bromide disk method under Infrared Spectrophotometry <2.25>, and compare the spectrum with the Reference Spectrum or the spectrum of previously dried Dexamethasone RS: both spectra exhibit similar intensities of absorption at the same wave numbers. If any difference appears between the spectra, dissolve Dexamethasone and Dexamethasone RS in acetone, respectively, then evaporate the acetone to dryness, and repeat the test on the residues.

Optical rotation <2.49> $[\alpha]_D^{20}$: +86 – +94° (after drying, 0.1 g, methanol, 10 mL, 100 mm).

Purity (1) Heavy metals <1.07>—Proceed with 1.0 g of Dexamethasone according to Method 2, and perform the test. Prepare the control solution with 3.0 mL of Standard Lead Solution (not more than 30 ppm).

(2) Related substances—Dissolve 0.18 g of Dexamethasone in 100 mL of acetonitrile. To 33 mL of this solution add a solution, prepared by dissolving 1.32 g of ammonium formate in water to make 1000 mL and adjusted to pH 3.6 with formic acid, to make 100 mL, and use this solution as the sample solution. To exactly 1 mL of the sample solution add

the mobile phase to make exactly 100 mL, and use this solution as the standard solution. Perform the test with exactly 10 μ L each of the sample solution and standard solution as directed under Liquid Chromatography <2.01> according to the following conditions, and determine each peak area by the automatic integration method: each peak area other than dexamethasone obtained from the sample solution is not larger than the peak area of dexamethasone from the standard solution, and the total area of the peaks other than dexamethasone from the sample solution is not larger than 2 times the peak area of dexamethasone from the standard solution.

Operating conditions—

Detector: An ultraviolet absorption photometer (wavelength: 254 nm).

Column: A stainless steel column 4.6 mm in inside diameter and 25 cm in length, packed with phenylsilylated silica gel for liquid chromatography (5 μ m in particle diameter).

Column temperature: A constant temperature of about 25°C.

Mobile phase: Dissolve 1.32 g of ammonium formate in 1000 mL of water, and adjust the pH to 3.6 with formic acid. To 670 mL of this solution add 330 mL of acetonitrile.

Flow rate: Adjust so that the retention time of dexamethasone is about 13 minutes.

Time span of measurement: About 4 times as long as the retention time of dexamethasone, beginning after the solvent peak.

System suitability—

Test for required detectability: To exactly 1 mL of the standard solution add the mobile phase to make exactly 10 mL. Confirm that the peak area of dexamethasone obtained with 10 μ L of this solution is equivalent to 8 to 12% of that with 10 μ L of the standard solution.

System performance: When the procedure is run with 10 μ L of the standard solution under the above operating conditions, the number of theoretical plates and the symmetry factor of the peak of dexamethasone are not less than 5000 and not more than 1.5, respectively.

System repeatability: When the test is repeated 6 times with 10 μ L of the standard solution under the above operating conditions, the relative standard deviation of the peak area of dexamethasone is not more than 1.0%.

Loss on drying <2.41> Not more than 0.5% (0.2 g, 105°C, 3 hours).

Residue on ignition <2.44> Not more than 0.1% (0.2 g, platinum crucible).

Assay Dissolve about 10 mg each of Dexamethasone and Dexamethasone RS, previously dried and accurately weighed, in 70 mL each of diluted methanol (1 in 2), add exactly 5 mL each of the internal standard solution, then add diluted methanol (1 in 2) to make 100 mL, and use these solutions as the sample solution and standard solution. Perform the test with 10 μ L each of the sample solution and standard solution as directed under Liquid Chromatography <2.01> according to the following conditions, and calculate the ratios, Q_T and Q_S , of the peak area of dexamethasone to that of the internal standard.

$$\begin{aligned} &\text{Amount (mg) of dexamethasone (C}_{22}\text{H}_{29}\text{FO}_5) \\ &= M_S \times Q_T / Q_S \end{aligned}$$

M_S : Amount (mg) of Dexamethasone RS taken

Internal standard solution—A solution of propyl parahydroxybenzoate in diluted methanol (1 in 2) (1 in 1000).

Operating conditions—

Detector: An ultraviolet absorption photometer (wavelength: 254 nm).

Column: A stainless steel column 4 mm in inside diameter and 30 cm in length, packed with octadecylsilylated silica gel for liquid chromatography (10 μ m in particle diameter).

Column temperature: A constant temperature of about 25°C.

Mobile phase: A mixture of water and acetonitrile (2:1).

Flow rate: Adjust so that the retention time of dexamethasone is about 6 minutes.

System suitability—

System performance: When the procedure is run with 10 μ L of the standard solution under the above operating conditions, dexamethasone and the internal standard are eluted in this order with the resolution between these peaks being not less than 6.

System repeatability: When the test is repeated 6 times with 10 μ L of the standard solution under the above operating conditions, the relative standard deviation of the ratio of the peak area of dexamethasone to that of the internal standard is not more than 1.0%.

Containers and storage Containers—Tight containers.

Storage—Light-resistant.

Dextran 40

デキストラン 40

Dextran 40 is a product obtained by partial decomposition of polysaccharide, which is produced by fermentation of sucrose with *Leuconostoc mesenteroides* van Tieghem (*Lactobacillaceae*), and the average molecular mass is about 40,000.

When dried, it contains not less than 98.0% and not more than 102.0% of dextran 40.

Manufacture Dextran 40 is produced by the manufacturing method to eliminate or minimize impurities having a possible antigenicity. The manufacturing method is verified to meet the antigenicity test.

Antigenicity Dissolve 10.0 g of Dextran 40 in isotonic sodium chloride solution to make 100 mL, sterilize, and use this solution as the sample solution. Inject 1.0 mL of the sample solution on 3 occasions at intervals of 2 days intraperitoneally to each of 4 well-nourished, healthy guinea pigs weighing 250 to 300 g. Inject 0.10 mL of horse serum intraperitoneally to each of 4 guinea pigs of another group as a control. Inject 0.20 mL of the sample solution intravenously to each of 2 guinea pigs of the first group 14 days after the first intraperitoneal injection and into each of the remaining 2 guinea pigs 21 days after the injection, and inject 0.20 mL of horse serum intravenously in the same manner into each guinea pig of the second group. Observe the signs of respiratory distress, collapse or death of the animals for 30 minutes after each intravenous injection and 24 hours later: the animals of the first group exhibit no signs mentioned above.

All the animals of the second group exhibit symptoms of respiratory distress or collapse and not less than 3 animals are killed.

Description Dextran 40 occurs as a white, amorphous powder. It is odorless and tasteless.

It is practically insoluble in ethanol (95) and in diethyl

ether.

It dissolves gradually in water.
It is hygroscopic.

Identification To 1 mL of a solution of Dextran 40 (1 in 3000) add 2 mL of anthrone TS: a blue-green color develops and turns gradually dark blue-green. Then to this solution add 1 mL of diluted sulfuric acid (1 in 2) or 1 mL of acetic acid (100): the solution does not change in color.

pH <2.54> Dissolve 1.0 g of Dextran 40 in 10 mL of water: the pH of this solution is between 5.0 and 7.0.

Purity (1) Clarity and color of solution—Dissolve 1.0 g of Dextran 40 in 10 mL of water by warming: the solution is clear and colorless.

(2) Chloride <1.03>—Perform the test with 2.0 g of Dextran 40. Prepare the control solution with 1.0 mL of 0.01 mol/L hydrochloric acid VS (not more than 0.018%).

(3) Heavy metals <1.07>—Proceed with 1.0 g of Dextran 40 according to Method 1, and perform the test. Prepare the control solution with 2.0 mL of Standard Lead Solution (not more than 20 ppm).

(4) Arsenic <1.11>—Prepare the test solution with 1.5 g of Dextran 40 according to Method 1, and perform the test (not more than 1.3 ppm).

(5) Nitrogen—Weigh accurately about 2 g of Dextran 40, previously dried, and perform the test as directed under Nitrogen Determination <1.08>, where 10 mL of sulfuric acid is used for decomposition, and 45 mL of a solution of sodium hydroxide (2 in 5) is added: the amount of nitrogen (N: 14.01) is not more than 0.010%.

(6) Reducing substances—Weigh exactly 3.00 g of Dextran 40, previously dried, dissolve in water to make exactly 50 mL, and use this solution as the sample solution. Separately, weigh exactly 0.450 g of glucose, previously dried, dissolve in water to make exactly 500 mL, and use this solution as the control solution. Pipet 5 mL each of the sample solution and the control solution, and add water to make exactly 50 mL, respectively. Pipet 5 mL each of these solutions, add 5 mL of alkaline copper TS, exactly measured, and heat for 15 minutes in a water bath. After cooling, add 1 mL of a solution of potassium iodine (1 in 40) and 1.5 mL of dilute sulfuric acid, and titrate <2.50> with 0.005 mol/L sodium thiosulfate VS (indicator: 2 mL of starch TS).

The titrant consumed for the sample solution is not less than that for the control solution.

Loss on drying <2.41> Not more than 5.0% (1 g, 105°C, 6 hours).

Residue on ignition <2.44> Not more than 0.1% (1 g).

Bacterial endotoxins <4.01> Less than 2.5 EU/g.

Viscosity <2.53> (1) Dextran 40—Weigh accurately 0.2 to 0.5 g of Dextran 40, previously dried, dissolve in water to make exactly 100 mL, and use this solution as the sample solution. Perform the test with the sample solution and with water as directed in Method 1 at 25°C: the intrinsic viscosity is between 0.16 and 0.19.

(2) High-molecular fraction—Weigh accurately about 6 g of Dextran 40, previously dried, dissolve in water to make exactly 100 mL, and transfer to a flask. Add slowly enough methanol to get 7% to 10% of the precipitate (usually 80 to 90 mL) at 25 ± 1°C with stirring. Dissolve the precipitate at 35°C in a water bath with occasional shaking, and allow to stand for more than 15 hours at 25 ± 1°C. Remove the supernatant liquid by decantation, and heat the precipitate of the lower layer to dryness on a water bath. Dry

the residue, and determine the intrinsic viscosity of the dried substance as directed in (1): the value is not more than 0.27.

(3) Low-molecular fraction—Weigh accurately about 6 g of Dextran 40, previously dried, dissolve in water to make exactly 100 mL, and transfer to a flask. Add slowly enough methanol to get 90% to 93% of the precipitate (usually 115 to 135 mL) at 25 ± 1°C with stirring, centrifuge at 25°C, and evaporate the supernatant liquid to dryness on a water bath. Dry the residue, and determine the intrinsic viscosity of the dried substance as directed in (1): the value is not less than 0.09.

Assay Weigh accurately about 3 g of Dextran 40, previously dried, dissolve in water to make exactly 50 mL, and use this solution as the sample solution. Determine the optical rotation α_D with the sample solution as directed under Optical Rotation Determination <2.49> in a 100-mL cell at 20 ± 1°C.

$$\text{Amount (mg) of dextran 40} = \alpha_D \times 253.8$$

Containers and storage Containers—Tight containers.

Dextran 40 Injection

デキストラン 40 注射液

Dextran 40 Injection is an aqueous injection.

It contains not less than 9.5 w/v% and not more than 10.5 w/v% of dextran 40.

Method of preparation

Dextran 40	10 g
Isotonic Sodium Chloride Solution	a sufficient quantity
To make 100 mL	

Prepare as directed under Injections, with the above ingredients.

No preservative is added.

Description Dextran 40 Injection is a clear and colorless liquid. It is slightly viscous.

Identification (1) Dilute 1 mL of Dextran 40 Injection with water to 200 mL, and to 1 mL of the diluted solution add 2 mL of anthrone TS: a blue-green color develops and turns gradually dark blue-green. Add 1 mL of diluted sulfuric acid (1 in 2) or 1 mL of acetic acid (100) to this solution: the solution does not change in color.

(2) Dextran 40 Injection responds to Qualitative Tests <1.09> for sodium salt and for chloride.

pH <2.54> 4.5 – 7.0

Bacterial endotoxins <4.01> Less than 0.50 EU/mL.

Extractable volume <6.05> It meets the requirement.

Viscosity <2.53> To 2 to 5 mL of Dextran 40 Injection add isotonic sodium chloride solution to make exactly 100 mL, and use this solution as the sample solution. Perform the test with the sample solution and with isotonic sodium chloride solution as directed in Method 1 at 25°C: the intrinsic viscosity is between 0.16 and 0.19. Calculate the concentration of the sample solution (g/100 mL) as directed in the Assay.

Assay To exactly 30 mL of Dextran 40 Injection add water to make exactly 50 mL, and use this solution as the sample solution. Determine the optical rotation α_D with the sample

solution as directed under Optical Rotation Determination <2.49> in a 100-mm cell at $20 \pm 1^\circ\text{C}$.

$$\begin{aligned} &\text{Amount (mg) of dextran 40 in 100 mL of} \\ &\text{Dextran 40 Injection} \\ &= \alpha_D \times 846.0 \end{aligned}$$

Containers and storage Containers—Hermetic containers. Plastic containers for aqueous injections may be used.

Storage—Avoid exposure to undue fluctuations in temperature.

Dextran 70

デキストラン 70

Dextran 70 is a product obtained by partial decomposition of polysaccharide, which is produced by fermentation of sucrose with *Leuconostoc mesenteroides* van Tieghem (*Lactobacillaceae*), and the average molecular mass is about 70,000.

When dried, it contains not less than 98.0% and not more than 102.0% of dextran 70.

Description Dextran 70 occurs as a white, amorphous powder. It is odorless and tasteless.

It is practically insoluble in ethanol (95) and in diethyl ether.

It dissolves gradually in water.

It is hygroscopic.

Identification To 1 mL of a solution of Dextran 70 (1 in 3000) add 2 mL of anthrone TS: a blue-green color develops and turns gradually dark blue-green. Then to this solution add 1 mL of diluted sulfuric acid (1 in 2) or 1 mL of acetic acid (100): the solution does not change in color.

pH <2.54> Dissolve 3.0 g of Dextran 70 in 50 mL of water: the pH of this solution is between 5.0 and 7.0.

Purity (1) Clarity and color of solution—Dissolve 1.0 g of Dextran 70 in 10 mL of water with warming: the solution is clear and colorless.

(2) Chloride <1.03>—With 2.0 g of Dextran 70, perform the test. Prepare the control solution with 1.0 mL of 0.01 mol/L hydrochloric acid VS (not more than 0.018%).

(3) Heavy metals <1.07>—Proceed with 1.0 g of Dextran 70 according to Method 1, and perform the test. Prepare the control solution with 2.0 mL of Standard Lead Solution (not more than 20 ppm).

(4) Arsenic <1.11>—Prepare the test solution with 1.5 g of Dextran 70 according to Method 1, and perform the test (not more than 1.3 ppm).

(5) Nitrogen—Weigh accurately about 2 g of Dextran 70, previously dried, perform the test as directed under Nitrogen Determination <1.08>, where 10 mL of sulfuric acid is used for decomposition, and 45 mL of a solution of sodium hydroxide (2 in 5) is added: the amount of nitrogen (N: 14.007) is not more than 0.010%.

(6) Reducing substances—Weigh exactly 3.00 g of Dextran 70, previously dried, dissolve in water to make exactly 50 mL, and use this solution as the sample solution. Separately, weigh exactly 0.300 g of glucose, previously dried, dissolve in water to make exactly 500 mL, and use this solution as the control solution. Pipet 5 mL each of the sample solution and the control solution, and add water to make exactly 50 mL, respectively. Pipet 5 mL of these diluted solutions, add exactly 5 mL of alkaline copper TS, and heat for

15 minutes in a water bath. After cooling, add 1 mL of a solution of potassium iodide (1 in 40) and 1.5 mL of dilute sulfuric acid, and titrate <2.50> with 0.005 mol/L sodium thio-sulfate VS (indicator: 2 mL of starch TS).

The titrant consumed for the sample solution is not less than that for the control solution.

Loss on drying <2.41> Not more than 5.0% (1 g, 105°C , 6 hours).

Residue on ignition <2.44> Not more than 0.1% (1 g).

Viscosity <2.53> (1) Dextran 70—Weigh accurately 0.2 to 0.5 g of Dextran 70, previously dried, dissolve in water to make exactly 100 mL, and use this solution as the sample solution. Perform the test with the sample solution and with water as directed in Method 1 at 25°C : the intrinsic viscosity is between 0.21 and 0.26.

(2) High-molecular fraction—Weigh accurately about 6 g of Dextran 70, previously dried, dissolve in water to make exactly 100 mL, and transfer to a flask. Add slowly enough methanol to get 7% to 10% of the precipitate (usually, 75 to 85 mL) at $25 \pm 1^\circ\text{C}$ with stirring. Dissolve the precipitate in a water bath at 35°C with occasional shaking, and allow to stand for more than 15 hours at $25 \pm 1^\circ\text{C}$. Remove the supernatant liquid by decantation, and heat the precipitate of the lower layer on a water bath to dryness. Dry the residue, and determine the intrinsic viscosity of the dried residue as directed in (1): the value is not more than 0.35.

(3) Low-molecular fraction—Weigh accurately about 6 g of Dextran 70, previously dried, dissolve in water to make exactly 100 mL, and transfer to a flask. Add slowly enough methanol to get 90% to 93% of the precipitate (usually 110 to 130 mL) at $25 \pm 1^\circ\text{C}$ with stirring, centrifuge at 25°C , and evaporate the supernatant liquid to dryness on a water bath. Dry the residue, and determine the intrinsic viscosity of the dried residue as directed in (1): the value is not less than 0.10.

Antigenicity Dissolve 6.0 g of Dextran 70 in isotonic sodium chloride solution to make 100 mL, sterilize, and use this solution as the sample solution. Inject 1.0 mL of the sample solution on 3 occasions at intervals of 2 days intraperitoneally to each of 4 well-nourished, healthy guinea pigs weighing 250 to 300 g. Separately, inject 0.10 mL of horse serum intraperitoneally to each of 4 guinea pigs of another group as a control. Inject 0.20 mL of the sample solution intravenously to each of 2 guinea pigs of the first group 14 days after the first intraperitoneal injection and into each of the remaining 2 guinea pigs 21 days after the injection, and inject 0.20 mL of horse serum intravenously in the same manner into each guinea pig of the second group. Observe the signs of respiratory distress, collapse or death of the animals for 30 minutes after each intravenous injection and 24 hours later: the animals of the first group exhibit no signs mentioned above.

All the animals of the second group exhibit symptoms of respiratory distress or collapse and not less than 3 animals are killed.

Pyrogen <4.04> Dissolve 6.0 g of Dextran 70 in isotonic sodium chloride solution to make 100 mL, and perform the test: this solution meets the requirement.

Assay Weigh accurately about 3 g of Dextran 70, previously dried, dissolve in water to make exactly 50 mL, and use this solution as the sample solution. Determine the optical rotation α_D as directed under Optical Rotation Determination <2.49> in a 100-mm cell at $20 \pm 1^\circ\text{C}$.

Amount (mg) of dextran $70 \times \alpha_D = 253.8$

Containers and storage Containers—Tight containers.

Dextran Sulfate Sodium Sulfur 5

デキストラン硫酸エステルナトリウム イオウ 5

Dextran Sulfate Sodium Sulfur 5 is a sodium salt of sulfate ester obtained by sulfation of partial decomposition products of dextran, which is produced by fermentation of sucrose with *Leuconostoc mesenteroides* Van Tieghem (*Lactobacillaceae*).

Description Dextran Sulfate Sodium Sulfur 5 occurs as a white to light yellow-white powder. It is odorless, and has a saline taste.

It is freely soluble in water and practically insoluble in ethanol (95) and in diethyl ether.

It is hygroscopic.

Identification (1) To 10 mL of a solution of toluidine blue (1 in 100,000) add 0.05 mL of a solution of Dextran Sulfate Sodium Sulfur 5 (3 in 50) dropwise: a color of the solution changes from blue to red-purple.

(2) To 1 mL of a solution of Dextran Sulfate Sodium Sulfur 5 (1 in 1500) add 2 mL of anthrone TS: a blue-green color develops, which turns dark blue-green gradually. Then, add 1 mL of diluted sulfuric acid (1 in 2) or 1 mL of acetic acid (100) to this solution: the solution remains dark blue-green.

(3) A solution of Dextran Sulfate Sodium Sulfur 5 (1 in 100) responds to Qualitative Tests <1.09> (1) for sodium salt.

Optical rotation <2.49> $[\alpha]_D^{20}$: +135.0 – +155.0° (1.5 g calculated on the dried basis, water, 25 mL, 100 mm).

Viscosity <2.53> Weigh accurately about 1.5 g of Dextran Sulfate Sodium Sulfur 5, calculated on the dried basis, dissolve in a solution of sodium chloride (29 in 500) to make exactly 100 mL, and use this solution as the sample solution. Perform the test with the sample solution and a solution of sodium chloride (29 in 500) at $25 \pm 0.02^\circ\text{C}$ as directed: the intrinsic viscosity is between 0.030 and 0.040.

pH <2.54> Dissolve 1.0 g of Dextran Sulfate Sodium Sulfur 5 in 20 mL of water: the pH of this solution is between 5.5 and 7.5.

Purity (1) Clarity and color of solution—Dissolve 2.5 g of Dextran Sulfate Sodium Sulfur 5 in 50 mL of water: the solution is clear. And, determine the absorbance of the solution at 420 nm as directed under Ultraviolet-visible Spectrophotometry <2.24>: not more than 0.090.

(2) Chloride <1.03>—Perform the test with 0.10 g of Dextran Sulfate Sodium Sulfur 5. Prepare the control solution with 0.30 mL of 0.01 mol/L hydrochloric acid VS (not more than 0.106%).

(3) Sulfate <1.14>—Dissolve 0.10 g of Dextran Sulfate Sodium Sulfur 5 in 6 mL of water, add 0.6 mL of barium chloride TS, and heat in a water bath for 4 minutes. After cooling, add 1 mL of dilute hydrochloric acid and water to make 50 mL, allow to stand for 10 minutes, and observe: the turbidity of the solution is not more intense than that of the control solution. Prepare the control solution as follows: to 0.50 mL of 0.005 mol/L sulfuric acid VS add 6 mL of water, and proceed in the same manner (not more than 0.240%).

(4) Heavy metals <1.07>—Proceed with 1.0 g of Dextran Sulfate Sodium Sulfur 5 according to Method 2, and per-

form the test. Prepare the control solution with 2.0 mL of Standard Lead Solution (not more than 20 ppm).

(5) Arsenic <1.11>—Prepare the test solution with 1.0 g of Dextran Sulfate Sodium Sulfur 5 according to Method 3, and perform the test (not more than 2 ppm).

Sulfur content Weigh accurately about 1.0 g of Dextran Sulfate Sodium Sulfur 5, dissolve in 5 mL of water, add 1.5 mL of hydrochloric acid, and heat in a water bath for 1 hour. After cooling, add water to make exactly 100 mL, and use this solution as the sample solution. To exactly 10 mL of the sample solution add exactly 20 mL of 0.02 mol/L barium chloride VS, add 5 mL of methanol, and heat in a water bath for 30 minutes. After cooling, neutralize with sodium hydroxide TS, and add 70 mL of water, 10 mL of a solution of zinc disodium ethylenediamine tetraacetate tetrahydrate (1 in 20), 3 mL of ammonium chloride TS and 7 mL of strong ammonium water, and titrate <2.50> with 0.02 mol/L disodium dihydrogen ethylenediamine tetraacetate VS until the color of the solution changes from red to light blue (indicator: 5 drops of eriochrome black T TS). Perform a blank determination in the same manner. Amount of sulfur (S: 32.07), calculated on the dried basis, is between 3.0 and 6.0%.

Each mL of 0.02 mol/L barium chloride VS
= 0.6414 mg of S

Loss on drying <2.41> Not more than 10.0% (0.5 g, in vacuum, phosphorus (V) oxide, 60°C , 4 hours).

Containers and storage Containers—Tight containers.

Dextran Sulfate Sodium Sulfur 18

デキストラン硫酸エステルナトリウム イオウ 18

Dextran Sulfate Sodium Sulfur 18 is a sodium salt of sulfate ester obtained by sulfation of partial decomposition products of dextran, which is produced by fermentation of sucrose with *Leuconostoc mesenteroides* Van Tieghem (*Lactobacillaceae*).

Description Dextran Sulfate Sodium Sulfur 18 occurs as a white to light yellow-white powder. It is odorless, and has a saline taste.

It is freely soluble in water and practically insoluble in ethanol (95) and in diethyl ether.

It is hygroscopic.

Identification (1) To 10 mL of a solution of toluidine blue (1 in 100,000) add 0.05 mL of a solution of Dextran Sulfate Sodium Sulfur 18 (3 in 50) dropwise: a color of the solution changes from blue to red-purple.

(2) To 1 mL of a solution of Dextran Sulfate Sodium Sulfur 18 (1 in 1500) add 2 mL of anthrone TS: a blue-green color develops, which turns dark blue-green gradually. Then, add 1 mL of diluted sulfuric acid (1 in 2) or 1 mL of acetic acid (100) to this solution: the solution remains dark blue-green.

(3) A solution of Dextran Sulfate Sodium Sulfur 18 (1 in 100) responds to Qualitative Tests <1.09> (1) for sodium salt.

Optical rotation <2.49> $[\alpha]_D^{20}$: +90.0 – +110.0° (1.5 g calculated on the dried basis, water, 25 mL, 100 mm).

Viscosity <2.53> Weigh accurately about 1.5 g of Dextran Sulfate Sodium Sulfur 18, calculated on the dried basis, dissolve in a solution of sodium chloride (29 in 500) to make exactly 100 mL, and use this solution as the sample solution.

Perform the test with the sample solution and a solution of sodium chloride (29 in 500) at $25 \pm 0.02^\circ\text{C}$ as directed: the intrinsic viscosity is between 0.020 and 0.032.

pH <2.54> Dissolve 1.0 g of Dextran Sulfate Sodium Sulfur 18 in 20 mL of water: the pH of this solution is between 5.5 and 7.5.

Purity (1) Chloride <1.03>—Perform the test with 0.10 g of Dextran Sulfate Sodium Sulfur 18. Prepare the control solution with 0.30 mL of 0.01 mol/L hydrochloric acid VS (not more than 0.106%).

(2) Sulfate <1.14>—Dissolve 0.10 g of Dextran Sulfate Sodium Sulfur 18 in 6 mL of water, add 0.6 mL of barium chloride TS, and heat in a water bath for 4 minutes. After cooling, add 1 mL of dilute hydrochloric acid and water to make 50 mL, allow to stand for 10 minutes, and observe: the turbidity of the solution is not more intense than that of the control solution. Prepare the control solution as follows: to 1.0 mL of 0.005 mol/L sulfuric acid VS add 6 mL of water, and proceed in the same manner (not more than 0.480%).

(3) Heavy metals <1.07>—Proceed with 1.0 g of Dextran Sulfate Sodium Sulfur 18 according to Method 2, and perform the test. Prepare the control solution with 2.0 mL of Standard Lead Solution (not more than 20 ppm).

(4) Arsenic <1.11>—Prepare the test solution with 1.0 g of Dextran Sulfate Sodium Sulfur 18 according to Method 3, and perform the test (not more than 2 ppm).

Sulfur content Weigh accurately about 0.5 g of Dextran Sulfate Sodium Sulfur 18, dissolve in 5 mL of water, add 1.5 mL of hydrochloric acid, and heat in a water bath for 1 hour. After cooling, add water to make exactly 100 mL, and use this solution as the sample solution. To exactly 10 mL of the sample solution add exactly 20 mL of 0.02 mol/L barium chloride VS, add 5 mL of methanol, and heat in a water bath for 30 minutes. After cooling, neutralize with sodium hydroxide TS, and add 70 mL of water, 10 mL of a solution of zinc disodium ethylenediamine tetraacetate tetrahydrate (1 in 20), 3 mL of ammonium chloride TS and 7 mL of strong ammonium water, and titrate <2.50> with 0.02 mol/L disodium dihydrogen ethylenediamine tetraacetate VS until the color of the solution changes from red to light blue (indicator: 5 drops of eriochrome black T TS). Perform a blank determination in the same manner. Amount of sulfur (S: 32.07), calculated on the dried basis, is between 15.0 and 20.0%.

Each mL of 0.02 mol/L barium chloride VS
= 0.6414 mg of S

Loss on drying <2.41> Not more than 10.0% (0.5 g, in vacuum, phosphorus (V) oxide, 60°C , 4 hours).

Containers and storage Containers—Tight containers.

Dextrin

デキストリン

Description Dextrin occurs as a white or light yellow, amorphous powder or granules. It has a slight, characteristic odor and a sweet taste. It does not irritate the tongue.

Dextrin is freely soluble in boiling water, soluble in water, and practically insoluble in ethanol (95) and in diethyl ether.

Identification To 0.1 g of Dextrin add 100 mL of water, shake, and filter if necessary. To 5 mL of the filtrate add 1 drop of iodine TS: a light red-brown or light red-purple color develops.

Purity (1) Clarity and color of solution—Take 2.0 g of Dextrin in a Nessler tube, add 40 mL of water, dissolve by heating, cool, and add water to make 50 mL: the solution is colorless or light yellow. It is clear, and even if turbid, the turbidity is not more than that of the following control solution.

Control solution: To 1.0 mL of 0.005 mol/L sulfuric acid VS add 1 mL of dilute hydrochloric acid, 46 mL of water and 2 mL of barium chloride TS, allow to stand for 10 minutes, and shake before use.

(2) Acidity—To 1.0 g of Dextrin add 5 mL of water, dissolve by heating, cool, and add 1 drop of phenolphthalein TS and 0.50 mL of 0.1 mol/L sodium hydroxide VS: a red color develops.

(3) Chloride <1.03>—To 2.0 g of Dextrin add 80 mL of water, dissolve by heating, cool, add water to make 100 mL, and filter. Take 40 mL of the filtrate, and add 6 mL of dilute nitric acid and water to make 50 mL. Perform the test using this solution as the test solution. Prepare the control solution with 0.30 mL of 0.01 mol/L hydrochloric acid VS (not more than 0.013%).

(4) Sulfate <1.14>—To 45 mL of the filtrate obtained in (3) add 1 mL of dilute hydrochloric acid and water to make 50 mL, and perform the test using this solution as the test solution. Prepare the control solution with 0.35 mL of 0.005 mol/L sulfuric acid VS (not more than 0.019%).

(5) Oxalate—To 1.0 g of Dextrin add 20 mL of water, dissolve by heating, cool, add 1 mL of acetic acid (31), and filter. To 5 mL of the filtrate add 5 drops of calcium chloride TS: no turbidity is produced immediately.

(6) Calcium—To a 5-mL portion of the filtrate obtained in (5) add 5 drops of ammonium oxalate TS: no turbidity is immediately produced.

(7) Heavy metals <1.07>—Proceed with 0.5 g of Dextrin according to Method 2, and perform the test. Prepare the control solution with 2.5 mL of Standard Lead Solution (not more than 50 ppm).

Loss on drying <2.41> Not more than 10% (0.5 g, 105°C , 4 hours).

Residue on ignition <2.44> Not more than 0.5% (0.5 g).

Containers and storage Containers—Well-closed containers.

Dextromethorphan Hydrobromide Hydrate

デキストロメトルファン臭化水素酸塩水和物

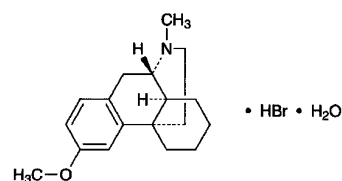

$\text{C}_{18}\text{H}_{25}\text{NO} \cdot \text{HBr} \cdot \text{H}_2\text{O}$: 370.32
(9*S*,13*S*,14*S*)-3-Methoxy-17-methylmorphinan
monohydrobromide monohydrate
[6700-34-1]

Dextromethorphan Hydrobromide Hydrate contains not less than 98.0% of dextromethorphan hydrobromide ($\text{C}_{18}\text{H}_{25}\text{NO} \cdot \text{HBr}$: 352.31), calculated on the anhydrous basis.

Description Dextromethorphan Hydrobromide Hydrate occurs as white, crystals or crystalline powder.

It is very soluble in methanol, freely soluble in ethanol (95) and in acetic acid (100), and sparingly soluble in water.

Melting point: about 126°C (Insert the capillary tube into the bath preheated to 116°C, and continue the heating so that the temperature rises at a rate of about 3°C per minute.)

Identification (1) Determine the absorption spectrum of a solution of Dextromethorphan Hydrobromide Hydrate (1 in 10,000) as directed under Ultraviolet-visible Spectrophotometry <2.24>, and compare the spectrum with the Reference Spectrum: both spectra exhibit similar intensities of absorption at the same wavelengths.

(2) Determine the infrared absorption spectrum of Dextromethorphan Hydrobromide Hydrate as directed in the potassium bromide disk method under Infrared Spectrophotometry <2.25>, and compare the spectrum with the Reference Spectrum: both spectra exhibit similar intensities of absorption at the same wave numbers.

(3) To 50 mL of a solution of Dextromethorphan Hydrobromide Hydrate (1 in 100) add 2 drops of phenolphthalein TS and sodium hydroxide TS until a red color develops. Add 50 mL of chloroform, shake, and add 5 mL of dilute nitric acid to 40 mL of the water layer. This solution responds to Qualitative Tests <1.09> for bromide.

Optical rotation <2.49> $[\alpha]_D^{20}$: +26 – +30° (0.34 g calculated on the anhydrous basis, water, 20 mL, 100 mm).

pH <2.54> Dissolve 1.0 g of Dextromethorphan Hydrobromide Hydrate in 100 mL of water: the pH of this solution is between 5.2 and 6.5.

Purity (1) Clarity and color of solution—Dissolve 0.20 g of Dextromethorphan Hydrobromide Hydrate in 20 mL of water: the solution is clear and colorless.

(2) *N,N*-dimethylaniline—To 0.50 g of Dextromethorphan Hydrobromide Hydrate add 20 mL of water, and dissolve by heating on a water bath. After cooling, add 2 mL of dilute acetic acid, 1 mL of sodium nitrite TS and water to make 25 mL: the solution has no more color than the following control solution.

Control solution: Dissolve 0.10 g of *N,N*-dimethylaniline in 400 mL of water by warming on a water bath, cool, and add water to make 500 mL. Pipet 5 mL of this solution, and add water to make 200 mL. To 1.0 mL of this solution add 2 mL of dilute acetic acid, 1 mL of sodium nitrite TS and water to make 25 mL.

(3) Heavy metals <1.07>—Proceed with 1.0 g of Dextromethorphan Hydrobromide Hydrate according to Method 4, and perform the test. Prepare the control solution with 2.0 mL of Standard Lead Solution (not more than 20 ppm).

(4) Phenolic compounds—Dissolve 5 mg of Dextromethorphan Hydrobromide Hydrate in 1 drop of dilute hydrochloric acid and 1 mL of water, add 2 drops of iron (III) chloride TS and 2 drops of potassium hexacyanoferrate (III) TS, shake, and allow to stand for 15 minutes: no blue-green color develops.

(5) Related substances—Dissolve 0.25 g of Dextromethorphan Hydrobromide Hydrate in 10 mL of methanol, and use this solution as the sample solution. Pipet 1 mL of the sample solution, add methanol to make exactly 200 mL, and use this solution as the standard solution. Perform the test with these solutions as directed under Thin-layer Chromatography <2.03>. Spot 5 μL each of the sample solution and standard solution on a plate of silica gel for thin-layer chromatography. Develop the plate with a mixture of tolu-

ene, ethyl acetate, methanol, dichloromethane and 13.5 mol/L ammonia TS (55:20:13:10:2) to a distance of about 15 cm, and air-dry the plate. Spray evenly bismuth potassium iodide TS on the plate, and then spray evenly hydrogen peroxide TS on the plate: the spots other than the principal spot obtained from the sample solution are not more intense than the spot from the standard solution.

Water <2.48> 4.0 – 5.5% (0.2 g, volumetric titration, back titration).

Residue on ignition <2.44> Not more than 0.1% (1 g).

Assay Weigh accurately about 0.5 g of Dextromethorphan Hydrobromide Hydrate, dissolve in 10 mL of acetic acid (100) and add 40 mL of acetic anhydride. Titrate <2.50> with 0.1 mol/L perchloric acid VS (potentiometric titration). Perform a blank determination, and make any necessary correction.

Each mL of 0.1 mol/L perchloric acid VS
= 35.23 mg of C₁₈H₂₅NO.HBr

Containers and storage Containers—Well-closed containers.

Diastase

ジアスターゼ

Diastase is an enzyme drug mainly prepared from malt. It has amylolytic activity.

It contains not less than 440 starch saccharifying activity units per g.

It is usually diluted with suitable diluents.

Description Diastase occurs as a light yellow to light brown powder.

It is hygroscopic.

Purity Rancidity—Diastase has no unpleasant or rancid odor, and has no unpleasant or rancid taste.

Loss on drying <2.41> Not more than 4.0% (1 g, 105°C, 5 hours).

Assay (i) Substrate solution—Use potato starch TS for amylolytic activity test.

(ii) Sample solution—Weigh accurately about 0.1 g of Diastase, and dissolve in water to make exactly 100 mL.

(iii) Procedure—Proceed as directed in 1.1. Measurement of starch saccharifying activity of 1. Assay for starch digestive activity under Digestion Test <4.03>.

Containers and storage Containers—Tight containers.

Storage—Not exceeding 30°C.

Diastase and Sodium Bicarbonate Powder

ジアスターゼ・重曹散

Method of preparation

Diastase	200 g
Sodium Bicarbonate	300 g
Precipitated Calcium Carbonate	400 g
Magnesium Oxide	100 g

To make 1000 g

Prepare before use as directed under Powders, with the above ingredients.

Description Diastase and Sodium Bicarbonate Powder occurs as a light yellow powder. It has a characteristic, salty taste.

Containers and storage Containers—Well-closed containers.

Compound Diastase and Sodium Bicarbonate Powder

複方ジアスターゼ・重曹散

Method of preparation

Diastase	200 g
Sodium Bicarbonate	600 g
Magnesium Oxide	150 g
Powdered Gentian	50 g

To make 1000 g

Prepare before use as directed under Powders, with the above ingredients.

Description Compound Diastase and Sodium Bicarbonate Powder occurs as a slightly brownish, light yellow powder. It has a characteristic odor and a bitter taste.

Containers and storage Containers—Well-closed containers.

Diazepam

ジアゼパム

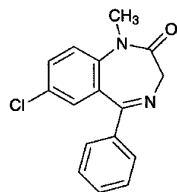

$C_{16}H_{13}ClN_2O$: 284.74

7-Chloro-1-methyl-5-phenyl-1,3-dihydro-2H-1,4-benzodiazepin-2-one
[439-14-5]

Diazepam, when dried, contains not less than 98.0% of diazepam ($C_{16}H_{13}ClN_2O$).

Description Diazepam occurs as a white to light yellow

crystalline powder. It is odorless, and has a slightly bitter taste.

It is freely soluble in acetone, soluble in acetic anhydride and in ethanol (95), sparingly soluble in diethyl ether, slightly soluble in ethanol (99.5), and practically insoluble in water.

Identification (1) Dissolve 10 mg of Diazepam in 3 mL of sulfuric acid, and observe under ultraviolet light (main wavelength: 365 nm): the solution shows a yellow-green fluorescence.

(2) Dissolve 2 mg of Diazepam in 200 mL of a solution of sulfuric acid in ethanol (99.5) (3 in 1000). Determine the absorption spectrum of the solution as directed under Ultraviolet-visible Spectrophotometry <2.24>, and compare the spectrum with the Reference Spectrum: both spectra exhibit similar intensities of absorption at the same wavelengths.

(3) Determine the infrared absorption spectrum of Diazepam, previously dried, as directed in the potassium bromide disk method under Infrared Spectrophotometry <2.25>, and compare the spectrum with the Reference Spectrum: both spectra exhibit similar intensities of absorption at the same wave numbers.

(4) Perform the test with Diazepam as directed under Flame Coloration Test <1.04> (2): a blue to blue-green color appears.

Melting point <2.60> 130 – 134°C

Purity (1) Clarity of solution—Dissolve 0.10 g of Diazepam in 20 mL of ethanol (95): the solution is clear.

(2) Chloride <1.03>—To 1.0 g of Diazepam add 50 mL of water, allow to stand for 1 hour, with occasional shaking, and filter. To 25 mL of the filtrate add 6 mL of dilute nitric acid and water to make 50 mL. Perform the test using this solution as the test solution. Prepare the control solution with 0.20 mL of 0.01 mol/L hydrochloric acid VS (not more than 0.014%).

(3) Heavy metals <1.07>—Proceed with 1.0 g of Diazepam according to Method 2, and perform the test. Prepare the control solution with 2.0 mL of Standard Lead Solution (not more than 20 ppm).

(4) Related substances—Dissolve 1.0 g of Diazepam in 10 mL of acetone, and use this solution as the sample solution. Pipette 1 mL of the sample solution, and add acetone to make exactly 100 mL. Pipet 1 mL of this solution, add acetone to make exactly 10 mL, and use this solution as the standard solution. Perform the test with these solutions as directed under Thin-layer Chromatography <2.03>. Spot 5 μ L each of the sample solution and standard solution on a plate of silica gel with fluorescent indicator for thin-layer chromatography. Develop the plate with a mixture of ethyl acetate and hexane (1:1) to a distance of about 12 cm, and air-dry the plate. Examine under ultraviolet light (main wavelength: 254 nm): the spots other than the principal spot obtained from the sample solution are not more intense than the spot from the standard solution.

Loss on drying <2.41> Not more than 0.5% (1 g, 105°C, 2 hours).

Residue on ignition <2.44> Not more than 0.1% (1 g).

Assay Weigh accurately about 0.6 g of Diazepam, previously dried, dissolve in 60 mL of acetic anhydride, and titrate <2.50> with 0.1 mol/L perchloric acid VS (potentiometric titration). Perform a blank determination in the same manner, and make any necessary correction.

Each mL of 0.1 mol/L perchloric acid VS
= 28.47 mg of $C_{16}H_{13}ClN_2O$

Containers and storage Containers—Tight containers.
Storage—Light-resistant.

Diazepam Tablets

ジアゼパム錠

Diazepam Tablets contain not less than 95.0% and not more than 105.0% of the labeled amount of diazepam ($C_{16}H_{13}ClN_2O$: 284.74).

Method of preparation Prepare as directed under Tablets, with Diazepam.

Identification To a portion of the powdered Diazepam Tablets, equivalent to 50 mg of Diazepam, add 50 mL of acetone, shake, and filter. Evaporate 1 mL of the filtrate on a water bath to dryness, and dissolve the residue with 100 mL of a solution of sulfuric acid in ethanol (99.5) (3 in 1000). Determine the absorption spectrum of this solution as directed under Ultraviolet-visible Spectrophotometry <2.24>: it exhibits maxima between 240 nm and 244 nm, between 283 nm and 287 nm, and between 360 nm and 370 nm.

Uniformity of dosage units <6.02> Perform the test according to the following method: it meets the requirement of the Content uniformity test.

To 1 tablet of Diazepam Tablets add 5 mL of water, and disintegrate the tablet by shaking. Then add 30 mL of methanol, shake for 10 minutes, add methanol to make exactly 50 mL, and centrifuge. Pipet V mL of the supernatant liquid, equivalent to 0.4 mg of diazepam ($C_{16}H_{13}ClN_2O$), add exactly 5 mL of the internal standard solution, then add methanol to make 20 mL, and use this solution as the sample solution. Separately, weigh accurately about 20 mg of diazepam for assay, previously dried at 105°C for 2 hours, and dissolve in methanol to make exactly 100 mL. Pipet 2 mL of this solution, add exactly 5 mL of the internal standard solution and add methanol to make 20 mL, and use this solution as the standard solution. Perform the test with 10 μ L each of the sample solution and standard solution as directed under Liquid Chromatography <2.01> under the following conditions, and calculate the ratios, Q_T and Q_S , of the peak area of diazepam to that of the internal standard.

$$\begin{aligned} \text{Amount (mg) of diazepam (C}_{16}\text{H}_{13}\text{ClN}_2\text{O)} \\ = M_S \times Q_T/Q_S \times 1/V \end{aligned}$$

M_S : Amount (mg) of diazepam for assay taken

Internal standard solution—A solution of ethyl parahydroxybenzoate in methanol (1 in 25,000).

Operating conditions—

Proceed as directed in the operating conditions in the Assay.

System suitability—

System performance: When the procedure is run with 10 μ L of the standard solution under the above operating conditions, the internal standard and diazepam are eluted in this order with the resolution between these peaks being not less than 6.

System repeatability: When the test is repeated 6 times with 10 μ L of the standard solution under the above operating conditions, the relative standard deviation of the ratio of the peak area of diazepam to that of the internal standard is not more than 1.0%.

Dissolution Being specified separately when the drug is granted approval based on the Law.

Assay Weigh accurately the mass of not less than 20 Diazepam Tablets, and powder. Weigh accurately a portion of the powder, equivalent to about 50 mg of diazepam ($C_{16}H_{13}ClN_2O$), add 10 mL of water, shake, then add 60 mL of methanol, shake for 10 minutes, add methanol to make exactly 100 mL, and centrifuge. Pipet 5 mL of the supernatant liquid, add exactly 5 mL of the internal standard solution, then add methanol to make 100 mL, and use this solution as the sample solution. Separately, weigh accurately about 50 mg of diazepam for assay, previously dried at 105°C for 2 hours, and dissolve in 10 mL of water and add methanol to make exactly 100 mL. Pipet 5 mL of this solution, add exactly 5 mL of the internal standard solution and add methanol to make 100 mL, and use this solution as the standard solution. Perform the test with 10 μ L each of the sample solution and standard solution as directed under Liquid Chromatography <2.01> according to the following conditions, and calculate the ratios, Q_T and Q_S , of the peak area of diazepam to that of the internal standard.

$$\begin{aligned} \text{Amount (mg) of diazepam (C}_{16}\text{H}_{13}\text{ClN}_2\text{O)} \\ = M_S \times Q_T/Q_S \end{aligned}$$

M_S : Amount (mg) of diazepam for assay taken

Internal standard solution—A solution of ethyl parahydroxybenzoate in methanol (1 in 5000).

Operating conditions—

Detector: An ultraviolet absorption photometer (wavelength: 254 nm).

Column: A stainless steel column 4 mm in inside diameter and 15 cm in length, packed with octadecylsilanized silica gel for liquid chromatography (5 μ m in particle diameter).

Column temperature: A constant temperature of about 40°C.

Mobile phase: A mixture of methanol and water (13:7).

Flow rate: Adjust so that the retention time of diazepam is about 10 minutes.

System suitability—

System performance: When the procedure is run with 10 μ L of the standard solution under the above operating conditions, the internal standard and diazepam are eluted in this order with the resolution between these peaks being not more than 6.

System repeatability: When the test is repeated 6 times with 10 μ L of the standard solution under the above operating conditions, the relative standard deviation of the ratio of the peak area of diazepam to that of the internal standard is not more than 1.0%.

Containers and storage Containers—Tight containers.

Dibekacin Sulfate

ジベカシン硫酸塩

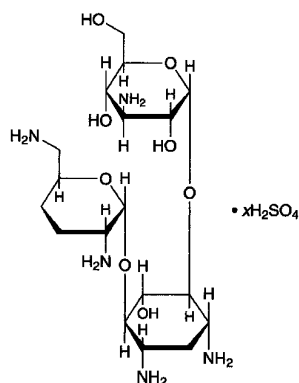

$C_{18}H_{37}N_5O_8 \cdot xH_2SO_4$

3-Amino-3-deoxy- α -D-glucopyranosyl-(1 \rightarrow 6)-[2,6-diamino-2,3,4,6-tetra-deoxy- α -D-erythro-hexopyranosyl-(1 \rightarrow 4)]-2-deoxy-D-streptamine sulfate
[58580-55-5]

Dibekacin Sulfate is the sulfate of a derivative of bekanamycin.

It contains not less than 640 μ g (potency) and not more than 740 μ g (potency) per mg, calculated on the dried basis. The potency of Dibekacin Sulfate is expressed as mass (potency) of dibekacin ($C_{18}H_{37}N_5O_8$; 451.52).

Description Dibekacin Sulfate occurs as a white to yellow-white powder.

It is very soluble in water, and practically insoluble in ethanol (99.5).

Identification (1) Dissolve 20 mg each of Dibekacin Sulfate and Dibekacin Sulfate RS in 1 mL of water, and use these solutions as the sample solution and standard solution. Perform the test with these solutions as directed under Thin-layer Chromatography <2.03>. Spot 5 μ L each of the sample solution and standard solution on a plate of silica gel for thin-layer chromatography. Develop the plate with a mixture of ammonia solution (28) and methanol (1:1) to a distance of about 10 cm, and air-dry the plate. Spray evenly 0.2% ninhydrin-water saturated 1-butanol TS, and heat at 100°C for 10 minutes: the principal spots obtained from the sample solution and the spot from the standard solution show a purple-brown color and the same *R_f* value.

(2) To 5 mL of a solution of Dibekacin Sulfate (1 in 50) add 1 drop of barium chloride TS: a white precipitate is produced.

Optical rotation <2.49> $[\alpha]_D^{20}$: +96 – +106° (0.25 g calculated on the dried basis, water, 25 mL, 100 mm).

pH <2.54> The pH of a solution obtained by dissolving 1.0 g of Dibekacin Sulfate in 20 mL of water is between 6.0 and 8.0.

Purity (1) Clarity and color of solution—Dissolve 3.0 g of Dibekacin Sulfate in 10 mL of water: the solution is clear. Determine the absorbance of this solution at 400 nm as directed under Ultraviolet-visible Spectrophotometry <2.24>: not more than 0.15.

(2) Heavy metals <1.07>—Proceed with 1.0 g of Dibekacin Sulfate according to Method 1, and perform the test. Prepare the control solution with 2.0 mL of Standard Lead

Solution (not more than 20 ppm).

Loss on drying <2.41> Not more than 5.0% (1 g, reduced pressure not exceeding 0.67 kPa, 60°C, 3 hours).

Assay Perform the test according to the Cylinder-plate method as directed under Microbial Assay for Antibiotics <4.02> according to the following conditions.

(i) Test organism—*Bacillus subtilis* ATCC 6633

(ii) Culture medium—Use the medium i in 1) under (1) Agar media for seed and base layer having pH 6.5 to 6.6 after sterilization.

(iii) Standard solutions—Weigh accurately an amount of Dibekacin Sulfate RS, previously dried, equivalent to about 20 mg (potency), dissolve in diluted phosphate buffer solution (pH 6.0) (1 in 2) to make exactly 50 mL, and use this solution as the standard stock solution. Keep the standard stock solution at 5 to 15°C and use within 30 days. Take exactly a suitable amount of the standard stock solution before use, add 0.1 mol/L phosphate buffer solution (pH 8.0) to make solutions so that each mL contains 20 μ g (potency) and 5 μ g (potency), and use these solutions as the high concentration standard solution and the low concentration standard solution, respectively.

(iv) Sample solutions—Weigh accurately an amount of Dibekacin Sulfate, equivalent to about 20 mg (potency), and dissolve in water to make exactly 50 mL. Take exactly a suitable amount of this solution, add 0.1 mol/L phosphate buffer solution (pH 8.0) to make solutions so that each mL contains 20 μ g (potency) and 5 μ g (potency), and use these solutions as the high concentration sample solution and the low concentration sample solution, respectively.

Containers and storage Containers—Tight containers.

Dibekacin Sulfate Ophthalmic Solution

ジベカシン硫酸塩点眼液

Dibekacin Sulfate Ophthalmic Solution is an aqueous ophthalmic preparation.

It contains not less than 90.0% and not more than 110.0% of the labeled potency of dibekacin ($C_{18}H_{37}N_5O_8$; 451.52).

Method of preparation Prepare as directed under Ophthalmic Liquids and Solutions, with Dibekacin Sulfate.

Description Dibekacin Sulfate Ophthalmic Solution is a clear, colorless liquid.

Identification To a volume of Dibekacin Sulfate Ophthalmic Solution add water so that each mL contains about 2.5 mg (potency) of Dibekacin Sulfate, and use this solution as the sample solution. Separately, dissolve an amount of Dibekacin Sulfate RS, equivalent to 5 mg (potency), in 2 mL of water, and use this solution as the standard solution. Perform the test with these solutions as directed under Thin-layer Chromatography <2.03>. Spot 10 μ L each of the sample solution and standard solution on a plate of silica gel for thin-layer chromatography. Proceed as directed in the Identification (1) under Dibekacin Sulfate.

pH <2.54> 6.5 – 7.5

Foreign insoluble matter <6.11> It meets the requirement.

Insoluble particulate matter <6.08> It meets the require-

ment.

Sterility <4.06> Perform the test according to the Membrane filtration method: it meets the requirement.

Assay Perform the test according to the Cylinder-plate method as directed under Microbial Assay for Antibiotics <4.02> according to the following conditions.

(i) Test organism, culture medium and standard solutions—Proceed as directed in the Assay under Dibekacin Sulfate.

(ii) Sample solutions—Pipet a volume of Dibekacin Sulfate Ophthalmic Solution, equivalent to about 12 mg (potency), and add water to make exactly 30 mL. Pipet a suitable volume of this solution, add 0.1 mol/L phosphate buffer solution (pH 8.0) to make solutions so that each mL contains 20 μ g (potency) and 5 μ g (potency), and use these solutions as the high concentration sample solution and the low concentration sample solution, respectively.

Containers and storage Containers—Tight containers.

Dibucaine Hydrochloride

Cinchocaine Hydrochloride

ジブカイン塩酸塩

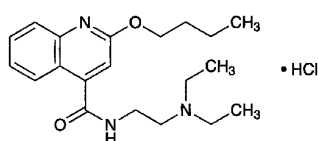

$C_{20}H_{29}N_3O_2 \cdot HCl$: 379.92

2-Butyloxy-*N*-(2-diethylaminoethyl)-4-quinolinecarboxamide monohydrochloride
[61-12-1]

Dibucaine Hydrochloride, when dried, contains not less than 98.0% of dibucaine hydrochloride ($C_{20}H_{29}N_3O_2 \cdot HCl$).

Description Dibucaine Hydrochloride occurs as white, crystals or crystalline powder.

It is very soluble in water, in ethanol (95) and in acetic acid (100), freely soluble in acetic anhydride, and practically insoluble in diethyl ether.

It is hygroscopic.

Identification (1) Determine the absorption spectrum of a solution of Dibucaine Hydrochloride in 1 mol/L hydrochloric acid TS (1 in 100,000) as directed under Ultraviolet-visible Spectrophotometry <2.24>, and compare the spectrum with the Reference Spectrum: both spectra exhibit similar intensities of absorption at the same wavelengths.

(2) Determine the infrared absorption spectrum of Dibucaine Hydrochloride, previously dried, as directed in the potassium bromide disk method under Infrared Spectrophotometry <2.25>, and compare the spectrum with the Reference Spectrum: both spectra exhibit similar intensities of absorption at the same wave numbers.

(3) A solution of Dibucaine Hydrochloride (1 in 10) responds to Qualitative Tests <1.09> for chloride.

pH <2.54> Dissolve 1.0 g of Dibucaine Hydrochloride in 50 mL of water: the pH of this solution is between 5.0 and 6.0.

Melting point <2.60> 95 – 100°C Charge Dibucaine Hydrochloride into a capillary tube for melting point determi-

nation, and dry in vacuum over phosphorus (V) oxide at 80°C for 5 hours. Seal immediately the open end of the tube, and determine the melting point.

Purity (1) Clarity and color of solution—Dissolve 1.0 g of Dibucaine Hydrochloride in 20 mL of water: the solution is clear and colorless. Determine the absorbance of this solution at 430 nm as directed under Ultraviolet-visible Spectrophotometry <2.24>, using water as the blank: it is not more than 0.03.

(2) Sulfate <1.14>—Perform the test with 0.30 g of Dibucaine Hydrochloride. Prepare the control solution with 0.35 mL of 0.005 mol/L sulfuric acid VS (not more than 0.056%).

(3) Heavy metals <1.07>—Proceed with 1.0 g of Dibucaine Hydrochloride according to Method 1, and perform the test. Prepare the control solution with 2.0 mL of Standard Lead Solution (not more than 20 ppm).

(4) Related substances—Dissolve 0.20 g of Dibucaine Hydrochloride in 5 mL of ethanol (95), and use this solution as the sample solution. Pipet 1 mL of the sample solution, add ethanol (95) to make exactly 20 mL, then pipet 2 mL of this solution, add ethanol (95) to make exactly 20 mL, and use this solution as the standard solution. Perform the test with these solutions as directed under Thin-layer Chromatography <2.03>. Spot 5 μ L each of the sample solution and standard solution on a plate of silica gel for thin-layer chromatography. Develop the plate with a mixture of ethyl acetate, water and acetic acid (100) (3:1:1) to a distance of about 10 cm, and air-dry the plate. Examine under ultraviolet (main wavelength: 254 nm): the spots other than the principal spot obtained from the sample solution are not more intense than the spot from the standard solution.

Loss on drying <2.41> Not more than 2.0% (1 g, in vacuum, phosphorus (V) oxide, 80°C, 5 hours).

Residue on ignition <2.44> Not more than 0.1% (1 g).

Assay Weigh accurately about 0.3 g of Dibucaine Hydrochloride, previously dried, dissolve in 50 mL of a mixture of acetic anhydride and acetic acid (100) (7:3), and titrate <2.50> with 0.1 mol/L perchloric acid VS (potentiometric titration). Perform a blank determination in the same manner, and make any necessary correction.

Each mL of 0.1 mol/L perchloric acid VS
= 19.00 mg of $C_{20}H_{29}N_3O_2 \cdot HCl$

Containers and storage Containers—Tight containers.

Diclofenac Sodium

ジクロフェナクナトリウム

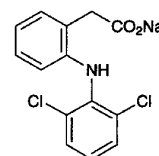

$C_{14}H_{10}Cl_2NNaO_2$: 318.13

Monosodium 2-(2,6-dichlorophenylamino)phenylacetate
[15307-79-6]

Diclofenac Sodium, when dried, contains not less than 98.5% of diclofenac sodium ($C_{14}H_{10}Cl_2NNaO_2$).

Description Diclofenac Sodium occurs as white to pale yellow

low-white, crystals or crystalline powder.

It is freely soluble in methanol and in ethanol (95), sparingly soluble in water and in acetic acid (100), and practically insoluble in diethyl ether.

It is hygroscopic.

Identification (1) To 1 mL of a solution of Diclofenac Sodium in methanol (1 in 250) add 1 mL of nitric acid: a dark red color develops.

(2) Perform the test with 5 mg of Diclofenac Sodium as directed under Flame Coloration Test <1.04> (2): a light green color appears.

(3) Determine the infrared absorption spectrum of Diclofenac Sodium, previously dried, as directed in the potassium bromide disk method under Infrared Spectrophotometry <2.25>, and compare the spectrum with the Reference Spectrum: both spectra exhibit similar intensities of absorption at the same wave numbers.

(4) A solution of Diclofenac Sodium (1 in 100) responds to Qualitative Tests <1.09> for sodium salt.

Purity (1) Heavy metals <1.07>—Proceed with 2.0 g of Diclofenac Sodium according to Method 2, and perform the test. Prepare the control solution with 2.0 mL of Standard Lead Solution (not more than 10 ppm).

(2) Arsenic <1.11>—Prepare the test solution with 1.0 g of Diclofenac Sodium according to Method 3, and perform the test (not more than 2 ppm).

(3) Related substances—Dissolve 0.05 g of Diclofenac Sodium in 50 mL of the mobile phase, and use this solution as the sample solution. Pipet 2 mL of the sample solution, and add the mobile phase to make exactly 50 mL. Pipet 5 mL of this solution, add the mobile phase to make exactly 100 mL, and use this solution as the standard solution. Perform the test with exactly 20 μ L each of these solutions as directed under Liquid Chromatography <2.01> according to the following conditions. Determine each peak area of these solutions by the automatic integration method: the area of each peak other than diclofenac obtained from the sample solution is not larger than the peak area of diclofenac from the standard solution.

Operating conditions—

Detector: An ultraviolet absorption photometer (wavelength: 240 nm).

Column: A stainless steel column 4.6 mm in inside diameter and 25 cm in length, packed with octadecylsilanized silica gel for liquid chromatography (7 μ m in particle diameter).

Column temperature: A constant temperature of about 40°C.

Mobile phase: A mixture of methanol and diluted acetic acid (100) (3 in 2500) (4:3).

Flow rate: Adjust so that the retention time of diclofenac is about 20 minutes.

Time span of measurement: About twice as long as the retention time of diclofenac, beginning after the solvent peak.

System suitability—

System performance: Dissolve 35 mg of ethyl parahydroxybenzoate and 0.05 g of propyl parahydroxybenzoate in 100 mL of the mobile phase. To 1 mL of this solution add the mobile phase to make 50 mL. When the procedure is run with 20 μ L of this solution under the above operating conditions, ethyl parahydroxybenzoate and propyl parahydroxybenzoate are eluted in this order with the resolution between these peaks being not less than 5.

System repeatability: When the test is repeated 6 times with 20 μ L of the standard solution under the above operating conditions, the relative standard deviation of the peak

areas of diclofenac is not more than 2.0%.

Loss on drying <2.41> Not more than 0.5% (1 g, 105°C, 3 hours).

Assay Weigh accurately about 0.5 g of Diclofenac Sodium, previously dried, dissolve in 40 mL of water in a separator, add 2 mL of dilute hydrochloric acid, and extract the precipitate formed with 50 mL of chloroform. Extract again with two 20-mL portions of chloroform, and filter the extract each time through a pledget of absorbent cotton moistened with chloroform. Wash the tip of the separator and the absorbent cotton with 15 mL of chloroform, combine the washing with the extracts, add 10 mL of a solution of 1 mol/L hydrochloric acid TS in ethanol (99.5) (1 in 100), and titrate <2.50> with 0.1 mol/L potassium hydroxide-ethanol VS from the first equivalent point to the second equivalent point (potentiometric titration).

Each mL of 0.1 mol/L potassium hydroxide-ethanol VS = 31.81 mg of $C_{14}H_{10}Cl_2NNaO_2$

Containers and storage Containers—Tight containers.

Diclofenac Sodium Suppositories

ジクロフェナクナトリウム坐剤

Diclofenac Sodium Suppositories contain not less than 93.0% and not more than 107.0% of the labeled amount of diclofenac sodium ($C_{14}H_{10}Cl_2NNaO_2$; 318.13).

Method of preparation Prepare as directed under Suppositories for Rectal Application, with Diclofenac Sodium.

Identification To an amount of Diclofenac Sodium Suppositories, equivalent to 25 mg of Diclofenac Sodium, add 200 mL of a mixture of methanol and 0.01 mol/L sodium hydroxide TS (99:1), and dissolve by warming. Cool while shaking, add a mixture of methanol and 0.01 mol/L sodium hydroxide TS (99:1) to make 250 mL, and filter through a pledget of absorbent cotton if necessary. To 10 mL of this solution add a mixture of methanol and 0.01 mol/L sodium hydroxide TS (99:1) to make 100 mL. Determine the absorption spectrum of this solution as directed under Ultraviolet-visible Spectrophotometry <2.24>: it exhibits a maximum between 280 nm and 284 nm.

Uniformity of dosage unit <6.02> Perform the test according to the following method: it meets the requirement of the Content uniformity test.

To 1 suppository of Diclofenac Sodium Suppositories add 5 mL of tetrahydrofuran, and sonicate to dissolve. Add a mixture of methanol and water (3:2) to make exactly 100 mL, shake, and filter through a membrane filter with a pore size not exceeding 0.5 μ m. Discard the first 5 mL of the filtrate, pipet V mL of the subsequent filtrate, add a mixture of methanol and water (3:2) to make exactly V' mL so that each mL contains about 0.125 mg of diclofenac sodium ($C_{14}H_{10}Cl_2NNaO_2$), and use this solution as the sample solution. Then, proceed as directed in the Assay.

Amount (mg) of diclofenac sodium ($C_{14}H_{10}Cl_2NNaO_2$)
= $M_S \times A_T/A_S \times V'/V \times 1/4$

M_S : Amount (mg) of diclofenac sodium for assay taken

Melting behavior of suppositories Perform the test according to Method 2 under Melting Point Determination <2.60>:

the melting range is between 33°C and 36°C.

Assay Weigh accurately the mass of not less than 20 Diclofenac Sodium Suppositories, cut into small pieces carefully, and mix uniformly. Weigh accurately a portion of the pieces, equivalent to about 25 mg of diclofenac sodium ($C_{14}H_{10}Cl_2NNaO_2$), add 5 mL of tetrahydrofuran, and sonicate to dissolve. Add a mixture of methanol and water (3:2) to make exactly 100 mL, shake, and filter through a membrane filter with a pore size not exceeding 0.5 μ m. Discard the first 5 mL of the filtrate, pipet 10 mL of the subsequent filtrate, add a mixture of methanol and water (3:2) to make exactly 20 mL, and use this solution as the sample solution. Separately, weigh accurately about 50 mg of diclofenac sodium for assay, previously dried, and dissolve in a mixture of methanol and water (3:2) to make exactly 100 mL. Pipet 5 mL of this solution, add a mixture of methanol and water (3:2) to make exactly 20 mL, and use this solution as the standard solution. Perform the test with exactly 20 μ L each of the sample solution and standard solution as directed under Liquid Chromatography <2.01> according to the following conditions, and determine the peak areas, A_T and A_S , of diclofenac in each solution.

$$\text{Amount (mg) of diclofenac sodium (C}_{14}\text{H}_{10}\text{Cl}_2\text{NNaO}_2) \\ = M_S \times A_T / A_S \times 1/2$$

M_S : Amount (mg) of diclofenac sodium for assay taken

Operating conditions—

Detector: An ultraviolet absorption photometer (wavelength: 254 nm).

Column: A stainless steel column 4.0 mm in inside diameter and 12.5 cm in length, packed with octadecylsilanized silica gel for liquid chromatography (5 μ m in particle diameter).

Column temperature: A constant temperature of about 25°C.

Mobile phase: Dissolve 13.6 g of sodium acetate trihydrate in water to make 1000 mL. To 200 mL of this solution add 300 mL of methanol.

Flow rate: Adjust so that the retention time of diclofenac is about 3.5 minutes.

System suitability—

System performance: When the procedure is run with 20 μ L of the standard solution under the above operating conditions, the number of theoretical plates and the symmetry factor of the peak of diclofenac are not less than 2000 and 0.7 to 1.5, respectively.

System repeatability: When the test is repeated 6 times with 20 μ L of the standard solution under the above operating conditions, the relative standard deviation of the peak area of diclofenac is not more than 1.0%.

Containers and storage Containers—Tight containers.

Storage—In a cold place.

Dicloxacillin Sodium Hydrate

ジクロキサシリンナトリウム水和物

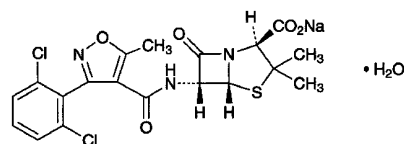

$C_{19}H_{16}Cl_2N_3NaO_5 \cdot H_2O$: 510.32

Monosodium (2*S*,5*R*,6*R*)-6-[[3-(2,6-dichlorophenyl)-5-methylisoxazole-4-carbonyl]amino]-3,3-dimethyl-7-oxo-4-thia-1-azabicyclo[3.2.0]heptane-2-carboxylate monohydrate
[13412-64-1]

Dicloxacillin Sodium Hydrate contains not less than 910 μ g (potency) and not more than 1020 μ g (potency) per mg, calculated on the anhydrous basis. The potency of Dicloxacillin Sodium Hydrate is expressed as mass (potency) of dicloxacillin ($C_{19}H_{17}Cl_2N_3O_5S$: 470.33).

Description Dicloxacillin Sodium Hydrate occurs as a white to light yellow-white crystalline powder.

It is freely soluble in water and in methanol, and soluble in ethanol (95).

Identification (1) Determine the absorption spectrum of a solution of Dicloxacillin Sodium Hydrate (1 in 2500) as directed under Ultraviolet-visible Spectrophotometry <2.24>, and compare the spectrum with the Reference Spectrum or the spectrum of a solution of Dicloxacillin Sodium RS prepared in the same manner as the sample solution: both spectra exhibit similar intensities of absorption at the same wavelengths.

(2) Determine the infrared absorption spectrum of Dicloxacillin Sodium Hydrate as directed in the potassium bromide disk method under Infrared Spectrophotometry <2.25>, and compare the spectrum with the Reference Spectrum or the spectrum of Dicloxacillin Sodium RS: both spectra exhibit similar intensities of absorption at the same wave numbers.

(3) Dicloxacillin Sodium Hydrate responds to Qualitative Tests <1.09> (1) for sodium salt.

Water <2.48> Not less than 3.0% and not more than 4.5% (0.1 g, volumetric titration, direct titration).

Assay Perform the test according to the Cylinder-plate method as directed under Microbial Assay for Antibiotics <4.02> according to the following conditions.

(i) Test organism—*Bacillus subtilis* ATCC 6633

(ii) Culture medium—Use the medium i in 1) under (1) Agar media for seed and base layer. Adjust the pH of the medium so that it will be 6.5 to 6.6 after sterilization.

(iii) Standard solutions—Weigh accurately an amount of Dicloxacillin Sodium RS equivalent to about 50 mg (potency), dissolve in phosphate buffer solution (pH 6.0) to make exactly 50 mL, and use this solution as the standard stock solution. Keep the standard stock solution at 5°C or below and use within 24 hours. Take exactly a suitable amount of the standard stock solution before use, add phosphate buffer solution (pH 6.0) to make solutions so that each mL contains 10 μ g (potency) and 2.5 μ g (potency), and use these solutions as the high concentration standard solution and the low concentration standard solution, respectively.

(iv) Sample solutions—Weigh accurately an amount of Dicloxacillin Sodium Hydrate equivalent to about 50 mg (potency), dissolve in phosphate buffer solution (pH 6.0) to make exactly 50 mL. Take exactly a suitable amount of the solution, add phosphate buffer solution (pH 6.0) to make solutions so that each mL contains 10 μ g (potency) and 2.5 μ g (potency), and use these solutions as the high concentration sample solution and the low concentration sample solution, respectively.

Containers and storage Containers—Tight containers.

Diethylcarbamazine Citrate

ジエチルカルバマジンクエン酸塩

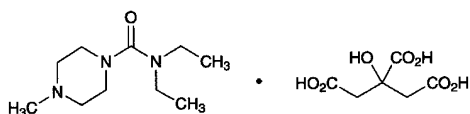

$C_{10}H_{21}N_3O \cdot C_6H_8O_7$: 391.42

N,N-Diethyl-4-methylpiperazine-1-carboxamide monocitrate
[1642-54-2]

Diethylcarbamazine Citrate, when dried, contains not less than 98.0% of diethylcarbamazine citrate ($C_{10}H_{21}N_3O \cdot C_6H_8O_7$).

Description Diethylcarbamazine Citrate occurs as a white, crystalline powder. It is odorless, and has an acid and bitter taste.

It is very soluble in water, soluble in ethanol (95), and practically insoluble in acetone, in chloroform and in diethyl ether.

A solution of Diethylcarbamazine Citrate (1 in 20) is acid. Diethylcarbamazine Citrate is hygroscopic.

Identification (1) Dissolve 0.5 g of Diethylcarbamazine Citrate in 2 mL of water, add 10 mL of sodium hydroxide TS, and extract with four 5-mL portions of chloroform. Wash the combined chloroform extracts with 10 mL of water, and evaporate the chloroform on a water bath. Add 1 mL of iodoethane to the residue, and boil gently under a reflux condenser for 5 minutes. Evaporate the excess iodoethane with the aid of a current of air, and dissolve the residue in 4 mL of ethanol (95). Cool the ethanol solution in an ice bath, with continuous stirring, add diethyl ether until precipitates are formed, and stir until crystallization is evident. Allow to stand in the ice bath for 30 minutes, and collect the precipitate. Dissolve the precipitate in 4 mL of ethanol (95), repeat the recrystallization in the same manner, then dry at 105°C for 4 hours: the crystals so obtained melt <2.60> between 151°C and 155°C.

(2) Neutralize the remaining aqueous layer obtained in (1) with dilute sulfuric acid: the solution responds to Qualitative Tests <1.09> (2) and (3) for citrate.

Melting point <2.60> 135.5 – 138.5°C

Purity Heavy metals <1.07>—Proceed with 2.0 g of Diethylcarbamazine Citrate according to Method 4, and perform the test. Prepare the control solution with 4.0 mL of Standard Lead Solution (not more than 20 ppm).

Loss on drying <2.41> Not more than 1.0% (2 g, 105°C, 4 hours).

Residue on ignition <2.44> Not more than 0.1% (1 g).

Assay Weigh accurately about 0.75 g of Diethylcarbamazine Citrate, previously dried, dissolve in 50 mL of acetic acid (100) by warming, cool, and titrate <2.50> with 0.1 mol/L perchloric acid VS (potentiometric titration). Perform a blank determination in the same manner, and make any necessary correction.

Each mL of 0.1 mol/L perchloric acid VS
= 39.14 mg of $C_{10}H_{21}N_3O \cdot C_6H_8O_7$

Containers and storage Containers—Tight containers.

Diethylcarbamazine Citrate Tablets

ジエチルカルバマジンクエン酸塩錠

Diethylcarbamazine Citrate Tablets contain not less than 95.0% and not more than 105.0% of the labeled amount of diethylcarbamazine citrate ($C_{10}H_{21}N_3O \cdot C_6H_8O_7$: 391.42).

Method of preparation Prepare as directed under Tablets, with Diethylcarbamazine Citrate.

Identification To a quantity of the powdered Diethylcarbamazine Citrate Tablets, equivalent to 0.1 g of Diethylcarbamazine Citrate, add 10 mL of water, shake well, and filter. To the filtrate add 1 mL of Reinecke salt TS: a light red precipitate is formed.

Uniformity of dosage units <6.02> Perform the Mass variation test, or the Content uniformity test according to the following method: it meets the requirement.

To 1 tablet of Diethylcarbamazine Citrate Tablets add 70 mL of the mobile phase, shake vigorously for 10 minutes, add the mobile phase to make exactly 100 mL, and filter through a membrane filter with a pore size not exceeding 0.45 μ m. Discard the first 3 mL of the filtrate, pipet *V* mL of the subsequent filtrate, equivalent to about 2.5 mg of diethylcarbamazine citrate ($C_{10}H_{21}N_3O \cdot C_6H_8O_7$), add exactly 5 mL of the internal standard solution, add the mobile phase to make 50 mL, and use this solution as the sample solution. Proceed as directed in the Assay.

Amount (mg) of diethylcarbamazine citrate
($C_{10}H_{21}N_3O \cdot C_6H_8O_7$)
= $M_S \times Q_T / Q_S \times 10 / V$

M_S : Amount (mg) of Diethylcarbamazine Citrate RS taken

Internal standard solution—A solution of 2-aminobenzimidazol in the mobile phase (1 in 12,500).

Dissolution <6.10> When the test is performed at 50 revolutions per minute according to the Paddle method, using 900 mL of water as the dissolution medium, the dissolution rate in 45 minutes of Diethylcarbamazine Citrate Tablets is not less than 80%.

Start the test with 1 tablet of Diethylcarbamazine Citrate Tablets, withdraw not less than 20 mL of the medium at the specified minute after starting the test, and filter through a membrane filter with a pore size not exceeding 0.45 μ m. Discard not less than 10 mL of the first filtrate, pipet *V* mL of the subsequent filtrate, add water to make exactly *V'* mL so that each mL contains about 56 μ g of diethylcarbamazine citrate ($C_{10}H_{21}N_3O \cdot C_6H_8O_7$), and use this solution as the sample solution. Separately, weigh accurately about 22 mg of Diethylcarbamazine Citrate RS, previously dried at 105°C for 4 hours, and dissolve in water to make exactly 100 mL.

Pipet 25 mL of this solution, add water to make exactly 100 mL, and use this solution as the standard solution. Perform the test with exactly 20 μ L each of the sample solution and standard solution as directed under Liquid Chromatography <2.01> according to the following conditions, and determine the peak areas, A_T and A_S , of diethylcarbamazine in each solution.

Dissolution rate (%) with respect to the labeled amount of diethylcarbamazine citrate ($C_{10}H_{21}N_3O \cdot C_6H_8O_7$)

$$= M_S \times A_T / A_S \times V' / V \times 1 / C \times 225$$

M_S : Amount (mg) of Diethylcarbamazine Citrate RS taken

C : Labeled amount (mg) of diethylcarbamazine citrate ($C_{10}H_{21}N_3O \cdot C_6H_8O_7$) in 1 tablet

Operating conditions—

Detector, column, column temperature, mobile phase, and flow rate: Proceed as directed in the operating conditions in the Assay.

System suitability—

System performance: When the procedure is run with 20 μ L of the standard solution under the above operating conditions, the number of theoretical plates and the symmetry factor of the peak of diethylcarbamazine are not less than 5000 and not more than 1.5, respectively.

System repeatability: When the test is repeated 6 times with 20 μ L of the standard solution under the above operating conditions, the relative standard deviation of the peak area of diethylcarbamazine is not more than 2.0%.

Assay Weigh accurately the mass of not less than 20 Diethylcarbamazine Citrate Tablets, and powder. Weigh accurately a portion of the powder, equivalent to about 50 mg of diethylcarbamazine citrate ($C_{10}H_{21}N_3O \cdot C_6H_8O_7$), add 70 mL of the mobile phase, shake vigorously for 10 minutes, add the mobile phase to make exactly 100 mL, and filter through a membrane filter with a pore size not exceeding 0.45 μ m. Discard the first 3 mL of the filtrate, pipet 5 mL of the subsequent filtrate, add exactly 5 mL of the internal standard solution, add the mobile phase to make 50 mL, and use this solution as the sample solution. Separately, weigh accurately about 25 mg of Diethylcarbamazine Citrate RS, previously dried at 105°C for 4 hours, dissolve in the mobile phase to make exactly 50 mL. Pipet 5 mL of this solution, add exactly 5 mL of the internal standard solution, add the mobile phase to make 50 mL, and use this solution as the standard solution. Perform the test with 20 μ L each of the sample solution and standard solution as directed under Liquid Chromatography <2.01> according to the following conditions, and calculate the ratios, Q_T and Q_S , of the peak area of diethylcarbamazine to that of the internal standard.

Amount (mg) of diethylcarbamazine citrate ($C_{10}H_{21}N_3O \cdot C_6H_8O_7$)

$$= M_S \times Q_T / Q_S \times 2$$

M_S : Amount (mg) of Diethylcarbamazine Citrate RS taken

Internal standard solution—A solution of 2-aminobenzimidazole in the mobile phase (1 in 12,500).

Operating conditions—

Detector: An ultraviolet absorption photometer (wavelength: 220 nm).

Column: A stainless steel column 4.6 mm in inside diameter and 15 cm in length, packed with octadecylsilanized silica gel for liquid chromatography (5 μ m in particle diameter).

Column temperature: A constant temperature of about

40°C.

Mobile phase: To 0.05 mol/L potassium dihydrogen phosphate TS add phosphoric acid to adjust the pH to 2.5. To 950 mL of this solution add 50 mL of methanol.

Flow rate: Adjust so that the retention time of diethylcarbamazine is about 14 minutes.

System suitability—

System performance: When the procedure is run with 20 μ L of the standard solution under the above operating conditions, diethylcarbamazine and the internal standard are eluted in this order with the resolution between these peaks being not less than 2.5.

System repeatability: When the test is repeated 6 times with 20 μ L of the standard solution under the above operating conditions, the relative standard deviation of the ratio of the peak area of diethylcarbamazine to that of the internal standard is not more than 1.0%.

Containers and storage Containers—Well-closed containers.

Difenidol Hydrochloride

ジフェニドール塩酸塩

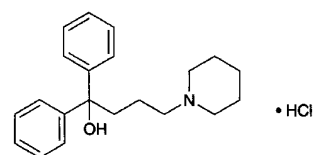

$C_{21}H_{27}NO \cdot HCl$: 345.91

1,1-Diphenyl-4-piperidin-1-ylbutan-1-ol monohydrochloride [3254-89-5]

Difenidol Hydrochloride, when dried, contains not less than 98.5% of difenidol hydrochloride ($C_{21}H_{27}NO \cdot HCl$).

Description Difenidol Hydrochloride occurs as white, crystals or crystalline powder. It is odorless.

It is freely soluble in methanol, soluble in ethanol (95), sparingly soluble in water and in acetic acid (100), and practically insoluble in diethyl ether.

Melting point: about 217°C (with decomposition).

Identification (1) Dissolve 0.01 g of Difenidol Hydrochloride in 1 mL of sulfuric acid: an orange-red color develops. To this solution add carefully 3 drops of water: the solution becomes yellowish brown, and colorless on the addition of 10 mL of water.

(2) To 5 mL of a solution of Difenidol Hydrochloride (1 in 100) add 2 mL of Reinecke salt TS: a light red precipitate is formed.

(3) To 10 mL of a solution of Difenidol Hydrochloride (1 in 100) add 2 mL of sodium hydroxide TS, and extract with two 15-mL portions of chloroform. Combine the extracts, wash with three 10-mL portions of water, evaporate the chloroform on a water bath, and dry the residue in a desiccator (in vacuum, silica gel, 55°C) for 5 hours: the residue melts <2.60> between 103°C and 106°C.

(4) A solution of Difenidol Hydrochloride (1 in 100) responds to Qualitative Tests <1.09> for chloride.

pH <2.54> Dissolve 1.0 g of Difenidol Hydrochloride in 100 mL of freshly boiled and cooled water: the pH of this solution is between 4.7 and 6.5.

Purity (1) Clarity and color of solution—Dissolve 1.0 g of Difenedol Hydrochloride in 10 mL of methanol: the solution is clear and colorless.

(2) Heavy metals <1.07>—Proceed with 1.0 g of Difenedol Hydrochloride according to Method 2, and perform the test. Prepare the control solution with 2.0 mL of Standard Lead Solution (not more than 20 ppm).

(3) Arsenic <1.11>—Prepare the test solution with 2.0 g of Difenedol Hydrochloride according to Method 3, and perform the test (not more than 1 ppm).

(4) Related substances—Dissolve 0.10 g of Difenedol Hydrochloride in methanol to make exactly 10 mL, and use this solution as the sample solution. Separately, dissolve 10 mg of 1,1-diphenyl-4-piperidino-1-butene hydrochloride for thin-layer chromatography in methanol to make exactly 20 mL, pipet 1 mL of this solution, add methanol to make exactly 10 mL, and use this solution as the standard solution. Perform the test with these solutions as directed under Thin-layer Chromatography <2.03>. Spot 5 μ L each of the sample solution and standard solution on a plate of silica gel with fluorescent indicator for thin-layer chromatography. Develop the plate with a mixture of toluene, methanol and acetic acid (100) (10:2:1) to a distance of about 15 cm, and air-dry the plate. Examine under ultraviolet light (main wavelength: 254 nm): the spots other than the principal spot obtained from the sample solution are not more intense than the spot from the standard solution.

Loss on drying <2.41> Not more than 0.5% (1 g, in vacuum, silica gel, 5 hours).

Residue on ignition <2.44> Not more than 0.1% (1 g).

Assay Weigh accurately about 0.35 g of Difenedol Hydrochloride, previously dried, dissolve in 30 mL of acetic acid (100) by warming if necessary, cool, add 30 mL of acetic anhydride, and titrate <2.50> with 0.05 mol/L perchloric acid VS (potentiometric titration). Perform a blank determination in the same manner, and make any necessary correction.

Each mL of 0.05 mol/L perchloric acid VS
= 17.30 mg of $C_{21}H_{27}NO.HCl$

Containers and storage Containers—Well-closed containers.

Diflorasone Diacetate

ジフロラゾン酢酸エステル

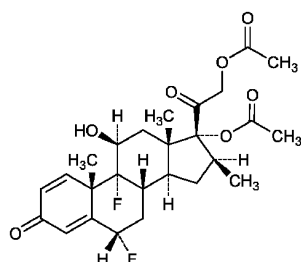

$C_{26}H_{32}F_2O_7$: 494.52

6 α ,9-Difluoro-11 β ,17,21-trihydroxy-16 β -methylpregna-1,4-diene-3,20-dione 17,21-diacetate
[33564-31-7]

Diflorasone Diacetate, when dried, contains not less than 97.0 and not more than 102.0% of diflorasone diacetate ($C_{26}H_{32}F_2O_7$).

Description Diflorasone Diacetate occurs as a white to pale yellow, crystals or crystalline powder.

It is soluble in acetonitrile, slightly soluble in ethanol (99.5), and practically insoluble in water.

Melting point: about 222°C (with decomposition).

Identification (1) Determine the infrared absorption spectrum of Diflorasone Diacetate, previously dried, as directed in the potassium bromide disk method under Infrared Spectrophotometry <2.25>, and compare the spectrum with the Reference Spectrum or the spectrum of previously dried Diflorasone Diacetate RS: both spectra exhibit similar intensities of absorption at the same wave numbers.

(2) Prepare the test solution with 10 mg of Diflorasone Diacetate as directed under Oxygen Flask Combustion Method <1.06>, using 20 mL of diluted 0.01 mol/L sodium hydroxide VS (1 in 40) as the absorbing liquid: the test solution responds to Qualitative Tests <1.09> for fluoride.

Optical rotation <2.49> $[\alpha]_D^{20}$: + 88 – + 93° (after drying, 0.1 g, acetonitrile, 10 mL, 100 mm).

Purity (1) Heavy metals <1.07>—Proceed with 1.0 g of Diflorasone Diacetate according to Method 2, and perform the test. Prepare the control solution with 1.0 mL of Standard Lead Solution (not more than 10 ppm).

(2) Related substances—Dissolve 20 mg of Diflorasone Diacetate in 20 mL of acetonitrile, and use this solution as the sample solution. Pipet 1 mL of the sample solution, add acetonitrile to make exactly 100 mL, and use this solution as the standard solution. Perform the test with exactly 10 μ L each of the sample solution and standard solution as directed under Liquid Chromatography <2.01> according to the following conditions. Determine each peak area by the automatic integration method: the areas of the peaks, having a relative retention time of about 0.5, about 0.7, about 0.9 and about 1.1 to diflorasone diacetate, obtained from the sample solution are respectively not larger than 1/4 times, 1/4 times, 1/2 times and 3/4 times the peak area of diflorasone diacetate from the standard solution, and the total area of the peaks other than diflorasone diacetate and the peaks mentioned above from the sample solutions is not larger than 1/5 times the peak area of diflorasone diacetate from the standard solution. Furthermore, the total area of the peaks other than diflorasone diacetate from the sample solution is not larger than 1.5 times the peak area of diflorasone diacetate from the standard solution.

Operating conditions—

Detector, column, column temperature, mobile phase, and flow rate: Proceed as directed in the operating conditions in the Assay.

Time span of measurement: About 1.4 times as long as the retention time of diflorasone diacetate, beginning after the solvent peak.

System suitability—

System performance: Proceed as directed in the system suitability in the Assay.

Test for required detectability: Pipet 2 mL of the standard solution, and add acetonitrile to make exactly 20 mL. Confirm that the peak area of diflorasone diacetate obtained with 10 μ L of this solution is equivalent to 7 to 13% of that with 10 μ L of the standard solution.

System repeatability: When the test is repeated 6 times with 10 μ L of the standard solution, the relative standard deviation of the peak area of diflorasone diacetate is not more than 2.0%.

Loss on drying <2.41> Not more than 1.0% (0.2 g, in vacuum, phosphorus (V) oxide, 60°C, 4 hours).

Residue on ignition <2.44> Not more than 0.2% (0.5 g, platinum crucible).

Assay Weigh accurately about 20 mg each of Diflorasone Diacetate and Diflorasone Diacetate RS, both previously dried, dissolve in exactly 4 mL each of the internal standard solution, add acetonitrile to make them 20 mL, and use these solutions as the sample solution and the standard solution, respectively. Perform the test with 10 μ L each of the sample solution and standard solution as directed under Liquid Chromatography <2.01> according to the following conditions, and calculate the ratios, Q_T and Q_S , of the peak area of diflorasone diacetate to that of the internal standard.

$$\begin{aligned} &\text{Amount (mg) of diflorasone diacetate (C}_{26}\text{H}_{23}\text{F}_2\text{O}_7) \\ &= M_S \times Q_T / Q_S \end{aligned}$$

M_S : Amount (mg) of Diflorasone Diacetate RS taken

Internal standard solution—A solution of methyl parahydroxybenzoate in acetonitrile (1 in 1000).

Operating conditions—

Detector: An ultraviolet absorption photometer (wavelength: 254 nm).

Column: A stainless steel column 6 mm in inside diameter and 15 cm in length, packed with octadecylsilanized silica gel for liquid chromatography (5 μ m in particle diameter).

Column temperature: A constant temperature of about 25°C.

Mobile phase: Dissolve 6.8 g of potassium dihydrogen phosphate in 1000 mL of water, and adjust to pH 4.0 with diluted phosphoric acid (1 in 200). To 550 mL of this solution add 400 mL of acetonitrile and 100 mL of tetrahydrofuran.

Flow rate: Adjust so that the retention time of diflorasone diacetate is about 15 minutes.

System suitability—

System performance: When the procedure is run with 10 μ L of the standard solution under the above operating conditions, the internal standard and diflorasone diacetate are eluted in this order with the resolution between these peaks being not less than 9.

System repeatability: When the test is repeated 6 times with 10 μ L of the standard solution under the above operating conditions, the relative standard deviation of the ratio of the peak area of diflorasone diacetate to that of the internal standard is not more than 1.0%.

Containers and storage Containers—Tight containers.

Diflucortolone Valerate

ジフルコルトロン吉草酸エステル

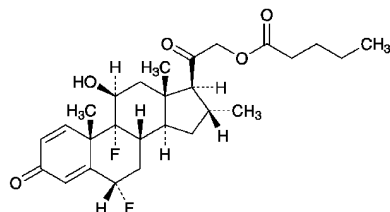

$C_{27}H_{36}F_2O_5$: 478.57

6 α ,9-Difluoro-11 β ,21-dihydroxy-16 α -methylpregna-1,4-diene-3,20-dione 21-pentanoate
[59198-70-8]

Diflucortolone Valerate contains not less than

98.0% and not more than 102.0% of diflucortolone valerate ($C_{27}H_{36}F_2O_5$), calculated on the dried basis.

Description Diflucortolone Valerate occurs as white, crystals or crystalline powder.

It is sparingly soluble in methanol and in ethanol (99.5), and practically insoluble in water.

Identification (1) Prepare the test solution by proceeding with 10 mg of Diflucortolone Valerate according to Oxygen Flask Combustion Method <1.06>, using a mixture of 0.5 mL of 0.01 mol/L sodium hydroxide TS and 20 mL of water as the absorbing liquid: the test solution responds to Qualitative Tests <1.09> for fluoride.

(2) Determine the absorption spectrum of a solution of Diflucortolone Valerate in methanol (3 in 200,000) as directed under Ultraviolet-visible Spectrophotometry <2.24>, and compare the spectrum with the Reference Spectrum or the spectrum of a solution of Diflucortolone Valerate RS prepared in the same manner as the sample solution: both spectra exhibit similar intensities of absorption at the same wavelengths.

(3) Determine the infrared absorption spectrum of Diflucortolone Valerate as directed in the potassium bromide disk method under Infrared Spectrophotometry <2.25>, and compare the spectrum with the Reference Spectrum or the spectrum of Diflucortolone Valerate RS: both spectra exhibit similar intensities of absorption at the same wave numbers.

Optical rotation <2.49> $[\alpha]_D^{20}$: +110 – +115° (0.1 g calculated on the dried basis, ethanol (99.5), 10 mL, 100 mm).

Melting point <2.60> 200 – 204°C

Purity (1) Heavy metals <1.07>—Proceed with 2.0 g of Diflucortolone Valerate in a platinum crucible according to Method 2, and perform the test. Prepare the control solution with 2.0 mL of Standard Lead Solution (not more than 10 ppm). Carbonize and incinerate as directed under Residue on Ignition <2.44>.

(2) Related substances—Use the sample solution obtained in the Assay as the sample solution. Perform the test with 10 μ L of the sample solution as directed under Liquid Chromatography <2.01> according to the following conditions. Determine each peak area of sample solution by the automatic integration method, and calculate the amounts of these peaks by the area percentage method: the amount of each peak of flucortolone valerate, 12 α diflucortolone valerate and 14 diflucortolone valerate, having the relative retention times of about 0.97, 1.03 and 1.05 to diflucortolone valerate, respectively, is not more than 0.6%, respectively; the amount of the peak of clocortolone valerate, having the relative retention time of about 1.09, is not more than 0.3%; and the amount of each peak other than those mentioned above is not more than 0.1%. Furthermore, the total amount of the peaks other than diflucortolone valerate is not more than 2.0%.

Operating conditions—

Detector, column, column temperature, mobile phase and flow rate: Proceed as directed in the operating conditions in the Assay.

Time span of measurement: About 1.4 times as long as the retention time of diflucortolone valerate, beginning after the solvent peak.

System suitability—

System performance and system repeatability: Proceed as directed in the system suitability in the Assay.

Test for required detectability: To 0.1 mL of the sample

solution, add a mixture of water and acetonitrile (1:1) to make 10 mL, and use this solution as the solution for system suitability test. Pipet 1 mL of the solution for system suitability test, and add a mixture of water and acetonitrile (1:1) to make exactly 20 mL. Confirm that the peak area of diflucortolone valerate obtained with 10 μ L of this solution is equivalent to 3.5 to 6.5% of that with 10 μ L of the solution for system suitability test.

Loss on drying <2.41> Not more than 0.5% (1 g, 105°C, 3 hours).

Residue on ignition <2.44> Not more than 0.1% (1 g, platinum crucible).

Assay Weigh accurately about 5 mg each of Diflucortolone Valerate and Diflucortolone Valerate RS (separately, determine the loss on drying <2.41> under the same conditions as Diflucortolone Valerate), dissolve each in a mixture of water and acetonitrile (1:1) to make exactly 10 mL, and use these solutions as the sample solution and the standard solution, respectively. Perform the test with exactly 10 μ L each of the sample solution and standard solution as directed under Liquid Chromatography <2.01> according to the following conditions, and determine the peak areas, A_T and A_S , of diflucortolone valerate in each solution.

$$\text{Amount (mg) of diflucortolone valerate (C}_{27}\text{H}_{36}\text{F}_2\text{O}_5) \\ = M_S \times A_T / A_S$$

M_S : Amount (mg) of Diflucortolone Valerate RS taken, calculated on dried basis

Operating conditions—

Detector: An ultraviolet absorption photometer (wavelength: 238 nm).

Column: A stainless steel column 4.6 mm in inside diameter and 25 cm in length, packed with sulfonamide group bound to hexadecylsilanized silica gel for liquid chromatography (5 μ m in particle diameter).

Column temperature: A constant temperature of about 25°C.

Mobile phase A: A mixture of 0.02 mol/L potassium dihydrogen phosphate TS, adjusted to pH 3.0 with phosphoric acid, and acetonitrile for liquid chromatography (11:9).

Mobile phase B: Acetonitrile for liquid chromatography.

Flowing of mobile phase: Control the gradient by mixing the mobile phases A and B as directed in the following table.

Time after injection of sample (min)	Mobile phase A (vol%)	Mobile phase B (vol%)
0 - 10	100 → 90	0 → 10
10 - 25	90	10
25 - 45	90 → 35	10 → 65
45 - 50	35	65

Flow rate: 1.0 mL per minute.

System suitability—

System performance: When the procedure is run with 10 μ L of the standard solution under the above operating conditions, the number of theoretical plates and the symmetry factor of the peak of diflucortolone valerate are not less than 10,000 and not more than 1.5, respectively.

System repeatability: When the test is repeated 6 times with 10 μ L of the standard solution under the above operating conditions, the relative standard deviation of the peak area of diflucortolone valerate is not more than 1.0%.

Containers and storage Containers—Tight containers.

Digoxin

ジゴキシン

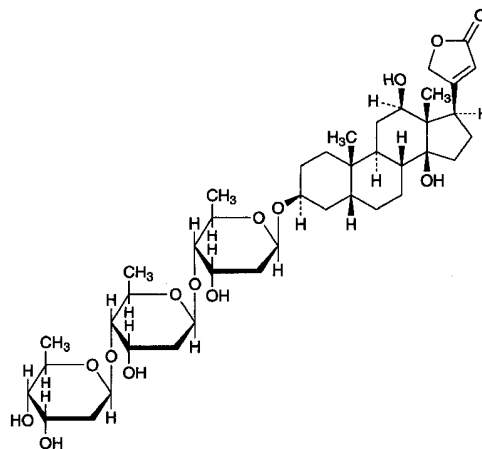

$C_{41}H_{64}O_{14}$: 780.94

3 β -[2,6-Dideoxy- β -D-ribo-hexopyranosyl-(1 \rightarrow 4)-2,6-dideoxy- β -D-ribo-hexopyranosyloxy]-12 β ,14-dihydroxy-5 β ,14 β -card-20(22)-enolide [20830-75-5]

Digoxin, when dried, contains not less than 96.0% and not more than 106.0% of digoxin ($C_{41}H_{64}O_{14}$).

Description Digoxin occurs as colorless or white crystals or a white crystalline powder.

It is freely soluble in pyridine, slightly soluble in ethanol (95), very slightly soluble in acetic acid (100), and practically insoluble in water.

Identification (1) Transfer 1 mg of Digoxin to a small test tube about 10 mm in inside diameter, dissolve in 1 mL of a solution of iron (III) chloride hexahydrate in acetic acid (100) (1 in 10,000), and underlay gently with 1 mL of sulfuric acid: at the zone of contact of the two liquids a brown ring free from a reddish color is produced, and the color of the upper layer near the contact zone changes to green through purple. Finally the entire acetic acid layer shows a green color through a deep blue color.

(2) Determine the infrared absorption spectrum of Digoxin, previously dried, as directed in the potassium bromide disk method under Infrared Spectrophotometry <2.25>, and compare the spectrum with the Reference Spectrum: both spectra exhibit similar intensities of absorption at the same wave numbers.

Optical rotation <2.49> $[\alpha]_D^{20}$: +10.0 – +13.0° (after drying, 0.20 g, dehydratead pyridine, 10 mL, 100 mm).

Purity (1) Clarity and color of solution—Dissolve 0.10 g of Digoxin in 15 mL of diluted ethanol (95) (4 in 5) by warming at 70°C: the solution is clear and colorless.

(2) Related substances—Dissolve 25.0 mg of Digoxin in 50 mL of warm ethanol (95), cool, and add ethanol (95) to make exactly 100 mL. Pipet 10 mL of this solution, add 10 mL of water and dilute ethanol to make exactly 50 mL, and use this solution as the sample solution. Separately, dissolve exactly 5.0 mg of Gitoxin for Purity RS, previously dried under reduced pressure at 105°C for 1 hour, in a mixture of acetonitrile and water (7:3) to make exactly 200 mL. Pipet 2 mL of this solution, add dilute ethanol to make exactly 50 mL, and use this solution as the standard solution. Perform

the test with exactly 10 μL each of the sample solution and standard solution as directed under Liquid Chromatography <2.01> according to the following conditions, and determine the peak areas, A_T and A_S , of digoxin: A_T is not larger than A_S , and the total area of the peaks other than digoxin and gitoxin from the sample solution, obtained by the area percentage method, is not more than 3%.

Operating conditions—

Detector, column, column temperature, mobile phase, and flow rate: Proceed as directed in the operating conditions in the Assay.

Time span of measurement: About 4 times as long as the retention time of digoxin, beginning after the solvent peak.

System suitability—

Test for required detectability: Dissolve 25 mg of Digoxin in 50 mL of warm ethanol (95), cool, and add ethanol (95) to make 100 mL. To 10 mL of this solution add 10 mL of water and dilute ethanol to make 50 mL, and use this solution as the solution for system suitability test. Pipet 2 mL of the solution for system suitability test, and add dilute ethanol to make exactly 100 mL. Pipet 5 mL of this solution, and add dilute ethanol to make exactly 100 mL. Confirm that the peak area of digoxin obtained with 10 μL of this solution is equivalent to 0.07 to 0.13% of that with 10 μL of the solution for system suitability test.

System performance: Dissolve 25 mg of Digoxin in 50 mL of warm ethanol (95), cool, and add ethanol (95) to make 100 mL. To 10 mL of this solution add 5 mL of a solution of propyl parahydroxybenzoate in ethanol (95) (1 in 4000), 10 mL of water and dilute ethanol to make 50 mL. When the procedure is run with 10 μL of this solution under the above operating conditions, digoxin and propyl parahydroxybenzoate are eluted in this order with the resolution between these peaks being not less than 5.

System repeatability: When the test is repeated 6 times with 10 μL of the solution for system suitability test under the above operating conditions, the relative standard deviation of the peak area of digoxin is not more than 2.5%.

Loss on drying <2.41> Not more than 1.0% (0.5 g, in vacuum, 105°C, 1 hour).

Residue on ignition <2.44> Not more than 0.5% (0.1 g).

Assay Weigh accurately about 25 mg each of Digoxin and Digoxin RS, previously dried, dissolve in 50 mL of warm ethanol (95), cool, and add ethanol (95) to make exactly 100 mL. Pipet 10 mL of these solutions, add exactly 5 mL of the internal standard solution, 10 mL of water and dilute ethanol to make 50 mL, and use these solutions as the sample solution and standard solution. Perform the test with 10 μL each of the sample solution and standard solution as directed under Liquid Chromatography <2.01> according to the following conditions, and calculate the ratios, Q_T and Q_S , of the peak area of digoxin to that of the internal standard.

$$\text{Amount (mg) of digoxin (C}_{41}\text{H}_{64}\text{O}_{14}) = M_S \times Q_T / Q_S$$

M_S : Amount (mg) of Digoxin RS taken

Internal standard solution—A solution of propyl parahydroxybenzoate in ethanol (95) (1 in 4000).

Operating conditions—

Detector: An ultraviolet absorption photometer (wavelength: 220 nm).

Column: A stainless steel column 4.6 mm in inside diameter and 25 cm in length, packed with octadecylsilanized silica gel for liquid chromatography (5 μm in particle diameter).

Column temperature: A constant temperature of about

30°C.

Mobile phase: A mixture of water and acetonitrile (7:3).

Flow rate: Adjust so that the retention time of digoxin is about 10 minutes.

System suitability—

System performance: When the procedure is run with 10 μL of the standard solution under the above operating conditions, digoxin and the internal standard are eluted in this order with the resolution between these peaks being not less than 5.

System repeatability: When the test is repeated 6 times with 10 μL of the standard solution under the above operating conditions, the relative standard deviation of the ratio of the peak area of digoxin to that of the internal standard is not more than 1.0%.

Containers and storage Containers—Tight containers.

Storage—Light-resistant.

Digoxin Injection

ジゴキシン注射液

Digoxin Injection is an aqueous injection.

It contains not less than 90.0% and not more than 105.0% of the labeled amount of digoxin ($\text{C}_{41}\text{H}_{64}\text{O}_{14}$: 780.94).

Method of preparation Prepare as directed under Injections, with a solution of Digoxin in 10 to 50 vol% ethanol.

Description Digoxin Injection is a clear, colorless liquid.

Identification Dilute Digoxin Injection, if necessary, with methanol so that each mL contains about 0.25 mg of Digoxin, and use this solution as the sample solution. In case where ingredients are suspected to affect the test, remove them by means of a solid-phase extraction. Separately, dissolve 0.5 mg of Digoxin RS in 2 mL of methanol, and use this solution as the standard solution. Perform the test with these solutions as directed under Thin-layer Chromatography <2.03>. Spot 10 μL each of the sample solution and standard solution on a plate of octadecylsilanized silica gel for thin-layer chromatography. Develop the plate with a mixture of methanol and water (7:3) to a distance of about 10 cm, and air-dry the plate. Spray evenly a mixture of a solution of trichloroacetic acid in ethanol (99.5) (1 in 4) and a freshly prepared solution of sodium toluenesulfonchloramide trihydrate (3 in 100) (4:1) on the plate, heat at 110°C for 10 minutes, and examine under ultraviolet light (main wavelength: 366 nm): the R_f values of the principal spots with the sample solution and the standard solution are not different each other.

Alcohol number <1.01> 0.8 – 1.2 (Method 1).

Purity Related substances—To a volume of Digoxin Injection, equivalent to about 2.5 mg of Digoxin, add dilute ethanol to make 50 mL, and use this solution as the sample solution. Perform the test with 10 μL of the sample solution as directed under Liquid Chromatography <2.01> according to the following conditions. Determine each peak area of the sample solution by the automatic integration method and calculate the amounts of these peaks by the area percentage method: the total amount of the peaks other than digoxin is not more than 5%.

Operating conditions—

Detector, column, column temperature, mobile phase and

flow rate: Proceed as directed in the operating conditions in the Assay.

Time span of measurement: About 4 times as long as the retention time of digoxin, beginning after the solvent peak.

System suitability—

Test for required detectability: Dissolve 25 mg of digoxin in 50 mL of warm ethanol (95), cool, add ethanol (95) to make 100 mL. To 10 mL of this solution add 10 mL of water and dilute ethanol to make 50 mL, and use this solution as the solution for system suitability test. Pipet 2 mL of the solution for system suitability test, and add dilute ethanol to make exactly 100 mL. Pipet 5 mL of this solution, and add dilute ethanol to make exactly 100 mL. Confirm that the peak area of digoxin obtained with 10 μ L this solution is equivalent to 0.07 to 0.13% of that with 10 μ L of the solution for system suitability test.

System performance: Dissolve 25 mg of digoxin in 50 mL of warm ethanol (95), cool, and add ethanol (95) to make 100 mL. To 10 mL of this solution add 5 mL of a solution of propyl parahydroxybenzoate in ethanol (95) (1 in 4000), 10 mL of water and dilute ethanol to make 50 mL. When the procedure is run with 10 μ L of this solution under the above operating conditions, digoxin and propyl parahydroxybenzoate are eluted in this order with the resolution between these peaks being not less than 5.

System repeatability: When the test is repeated 6 times with 10 μ L of the solution for system suitability test under the above operating conditions, the relative standard deviation of the peak area of digoxin is not more than 2.5%.

Bacterial endotoxins <4.01> Less than 200 EU/mg.

Extractable volume <6.05> It meets the requirements.

Foreign insoluble matter <6.06> Perform the test according to Method 1: it meets the requirement.

Insoluble particulate matter <6.07> Perform the test according to Method 1: it meets the requirement.

Sterility <4.06> Perform the test according to the Membrane filtration method: it meets the requirement.

Assay To an exact volume of Digoxin Injection, equivalent to about 2.5 mg of digoxin ($C_{41}H_{64}O_{14}$), add exactly 5 mL of the internal standard solution and dilute ethanol to make 50 mL, and use this solution as the sample solution. Separately, weigh accurately about 25 mg of Digoxin RS, previously dried under reduced pressure at 105°C for 1 hour, dissolve in 50 mL of warm ethanol (95), cool, and add ethanol (95) to make exactly 100 mL. Pipet 10 mL of this solution, add exactly 5 mL of the internal standard solution, 10 mL of water and dilute ethanol to make 50 mL, and use this solution as the standard solution. Perform the test with 10 μ L each of the sample solution and standard solution as directed under Liquid Chromatography <2.01> according to the following conditions, and calculate the ratios, Q_T and Q_S , of the peak area of digoxin to that of the internal standard.

$$\begin{aligned} &\text{Amount (mg) of digoxin (C}_{41}\text{H}_{64}\text{O}_{14}\text{)} \\ &= M_S \times Q_T / Q_S \times 1/10 \end{aligned}$$

M_S : Amount (mg) of Digoxin RS taken

Internal standard solution—A solution of propyl parahydroxybenzoate in ethanol (95) (1 in 4000).

Operating conditions—

Detector: An ultraviolet absorption photometer (wavelength: 220 nm).

Column: A stainless steel column 4.6 mm in inside diameter and 25 cm in length, packed with octadecylsilanized silica

gel for liquid chromatography (5 μ m in particle diameter).

Column temperature: A constant temperature of about 30°C.

Mobile phase: A mixture of water and acetonitrile (7:3).

Flow rate: Adjust so that the retention time of digoxin is about 10 minutes.

System suitability—

System performance: When the procedure is run with 10 μ L of the standard solution under the above operating conditions, digoxin and the internal standard are eluted in this order with the resolution between these peaks being not less than 5.

System repeatability: When the test is repeated 6 times with 10 μ L of the standard solution under the above operating conditions, the relative standard deviation of the ratio of the peak area of digoxin to that of the internal standard is not more than 1.0%.

Containers and storage Containers—Hermetic containers, and colored containers may be used.

Storage—Light-resistant.

Digoxin Tablets

ジゴキシン錠

Digoxin Tablets contain not less than 90.0% and not more than 105.0% of the labeled amount of digoxin ($C_{41}H_{64}O_{14}$: 780.94).

Method of preparation Prepare as directed under Tablets, with Digoxin.

Identification To an amount of powdered Digoxin Tablets, equivalent to 0.5 mg of Digoxin, add 2 mL of methanol, shake for 10 minutes, filter, and use the filtrate as the sample solution. Separately, dissolve 0.5 mg of Digoxin RS in 2 mL of methanol, and use this solution as the standard solution. Perform the test with these solutions as directed under Thin-layer Chromatography <2.03>. Spot 10 μ L each of the sample solution and standard solution on a plate of octadecylsilanized silica gel for thin-layer chromatography. Develop the plate with a mixture of methanol and water (7:3) to a distance of about 10 cm, and air-dry the plate. Spray evenly a mixture of a solution of trichloroacetic acid in ethanol (99.5) (1 in 4) and a freshly prepared solution of sodium toluenesulfonchloramide trihydrate (3 in 100) (4:1) on the plate, heat at 110°C for 10 minutes, and examine under ultraviolet light (main wavelength: 366 nm): the R_f values of the principal spots with the sample solution and the standard solution are not different each other.

Purity Related substances—Powder not less than 20 Digoxin Tablets. Weigh a portion of the powder equivalent to 2.5 mg of Digoxin, add 30 mL of dilute ethanol, sonicate for 20 minutes, and shake for 5 minutes. After cooling, add dilute ethanol to make 50 mL, filter, and use the filtrate as the sample solution. Perform the test with 10 μ L of the sample solution as directed under Liquid Chromatography <2.01> according to the following conditions. Determine each peak area of the sample solution by the automatic integration method and calculate the amount of these peaks by the area percentage method: the total amount of the peaks other than digoxin is not more than 5%.

Operating conditions—

Detector, column, column temperature, mobile phase and flow rate: Proceed as directed in the operating conditions in

the Assay.

Time span of measurement: About 4 times as long as the retention time of digoxin, beginning after the solvent peak.

System suitability—

Test for required detectability: Dissolve 25 mg of digoxin in 50 mL of warm ethanol (95), cool, add ethanol (95) to make 100 mL. To 10 mL of this solution add 10 mL of water and dilute ethanol to make 50 mL, and use this solution as the solution for system suitability test. Pipet 2 mL of the solution for system suitability test, and add dilute ethanol to make exactly 100 mL. Pipet 5 mL of this solution, and add dilute ethanol to make exactly 100 mL. Confirm that the peak area of digoxin obtained with 10 μ L of this solution is equivalent to 0.07 to 0.13% of that with 10 μ L of the solution for system suitability test.

System performance: Dissolve 25 mg of digoxin in 50 mL of warm ethanol (95), cool, and add ethanol (95) to make 100 mL. To 10 mL of this solution add 5 mL of a solution of propyl parahydroxybenzoate in ethanol (95) (1 in 4000), 10 mL of water and dilute ethanol to make 50 mL. When the procedure is run with 10 μ L of this solution under the above operating conditions, digoxin and propyl parahydroxybenzoate are eluted in this order with the resolution between these peaks being not less than 5.

System repeatability: When the test is repeated 6 times with 10 μ L of the solution for system suitability test under the above operating conditions, the relative standard deviation of the peak area of digoxin is not more than 2.5%.

Uniformity of dosage units <6.02> Perform the test according to the following method: it meets the requirement of the Content uniformity test.

To 1 tablet of Digoxin Tablets add 0.5 mL of water to disintegrate, then add exactly 0.5 mL of the internal standard solution, and add V mL of dilute ethanol so that each mL contains about 21 μ g of digoxin ($C_{41}H_{64}O_{14}$). Sonicate for 20 minutes, shake for 5 minutes, filter, and use the filtrate as the sample solution. Separately, weigh accurately about 25 mg of Digoxin RS, previously dried under reduced pressure at 105°C for 1 hour, dissolve in 50 mL of warm ethanol (95), cool, and add ethanol (95) to make exactly 100 mL. Pipet 10 mL of this solution, and add ethanol (95) to make exactly 20 mL. Pipet 1 mL of this solution, add exactly 0.5 mL of the internal standard solution, then add 1.5 mL of water and ($V - 2$) mL of dilute ethanol, and use this solution as the standard solution. Proceed with the sample solution and standard solution as directed in the Assay.

$$\begin{aligned} &\text{Amount (mg) of digoxin (C}_{41}\text{H}_{64}\text{O}_{14}\text{)} \\ &= M_S \times Q_T/Q_S \times 1/200 \end{aligned}$$

M_S : Amount (mg) of Digoxin RS taken

Internal standard solution—A solution of propyl parahydroxybenzoate in ethanol (95) (1 in 40,000/ V).

Dissolution <6.10> When the test is performed at 100 revolutions per minute according to the Basket method, using 500 mL of diluted hydrochloric acid (3 in 500) as the dissolution medium, the dissolution rate in 60 minutes of Digoxin Tablets is not less than 65%. No retest requirement is applied to Digoxin Tablets.

Start the test with 1 tablet of Digoxin Tablets, withdraw not less than 20 mL of the medium at the specified minute after starting the test, and filter through a membrane filter with a pore size not exceeding 0.8 μ m. Discard not less than 10 mL of the first filtrate, and use the subsequent filtrate as the sample solution. Separately, weigh accurately about 25 mg of Digoxin RS, previously dried in vacuum at 105°C for

1 hour, dissolve in a small portion of ethanol (95), and add a mixture of ethanol (95) and water (4:1) to make exactly 500 mL. Pipet 5 mL of this solution, add the dissolution medium to make exactly 500 mL, and use this solution as the standard solution. Pipet 2 mL each of the sample solution, the standard solution and the dissolution medium, and transfer to brown glass-stoppered test tubes. Add exactly 10 mL of 0.012 g/dL L-ascorbic acid-hydrochloric acid TS to these tubes, and shake. Immediately add exactly 1 mL of dilute hydrogen peroxide TS, shake well, and allow to stand at a constant temperature between 25°C and 30°C for 45 minutes. Determine the fluorescence intensities, F_T , F_S , and F_B , of these solutions at 360 nm of the excitation wavelength and at 485 nm of the fluorescence wavelength as directed under Fluorometry <2.22>, respectively.

Dissolution rate (%) with respect to the labeled amount of digoxin ($C_{41}H_{64}O_{14}$)

$$= M_S \times (F_T - F_B)/(F_S - F_B) \times 1/C$$

M_S : Amount (mg) of Digoxin RS taken

C : The labeled amount (mg) of digoxin ($C_{41}H_{64}O_{14}$) in 1 tablet

Assay Weigh accurately the mass of not less than 20 Digoxin Tablets, and powder. Weigh accurately a portion of the powder, equivalent to about 2.5 mg of digoxin ($C_{41}H_{64}O_{14}$), add 30 mL of dilute ethanol, sonicate for 20 minutes, and shake for 5 minutes. Add exactly 5 mL of the internal standard solution and dilute ethanol to make 50 mL, centrifuge, and use the supernatant liquid as the sample solution. Separately, weigh accurately about 25 mg of Digoxin RS, previously dried under reduced pressure at 105°C for 1 hour, dissolve in 50 mL of warm ethanol (95), cool, and add ethanol (95) to make exactly 100 mL. Pipet 10 mL of this solution, add exactly 5 mL of the internal standard solution, 10 mL of water and dilute ethanol to make 50 mL, and use this solution as the standard solution. Perform the test with 10 μ L each of the sample solution and standard solution as directed under Liquid Chromatography <2.01> according to the following conditions, and calculate the ratios, Q_T and Q_S , of the peak area of digoxin to that of the internal standard.

$$\begin{aligned} &\text{Amount (mg) of digoxin (C}_{41}\text{H}_{64}\text{O}_{14}\text{)} \\ &= M_S \times Q_T/Q_S \times 1/10 \end{aligned}$$

M_S : Amount (mg) of Digoxin RS taken

Internal standard solution—A solution of propyl parahydroxybenzoate in ethanol (95) (1 in 4000).

Operating conditions—

Detector: An ultraviolet absorption photometer (wavelength: 220 nm).

Column: A stainless steel column 4.6 mm in inside diameter and 25 cm in length, packed with octadecylsilanized silica gel for liquid chromatography (5 μ m in particle diameter).

Column temperature: A constant temperature of about 30°C.

Mobile phase: A mixture of water and acetonitrile (7:3).

Flow rate: Adjust so that the retention time of digoxin is about 10 minutes.

System suitability—

System performance: When the procedure is run with 10 μ L of the standard solution under the above operating conditions, digoxin and the internal standard are eluted in this order with the resolution between these peaks being not less than 5.

System repeatability: When the test is repeated 6 times with 10 μ L of the standard solution under the above operating conditions, the relative standard deviation of the ratio of

the peak area of digoxin to that of the internal standard is not more than 1.0%.

Containers and storage Containers—Tight containers.

Storage—Light-resistant.

Dihydrocodeine Phosphate

ジヒドロコデインリン酸塩

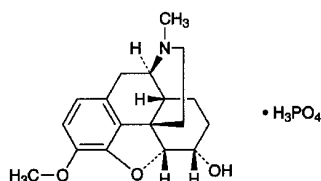

$C_{18}H_{23}NO_3 \cdot H_3PO_4$: 399.38

(5*R*,6*S*)-4,5-Epoxy-3-methoxy-17-methylmorphinan-6-ol monophosphate

[24204-13-5]

Dihydrocodeine Phosphate contains not less than 98.0% of dihydrocodeine phosphate ($C_{18}H_{23}NO_3 \cdot H_3PO_4$), calculated on the dried basis.

Description Dihydrocodeine Phosphate occurs as a white to yellowish white crystalline powder.

It is freely soluble in water and in acetic acid (100), slightly soluble in ethanol (95), and practically insoluble in diethyl ether.

The pH of a solution of 1.0 g of Dihydrocodeine Phosphate in 10 mL of water is between 3.0 and 5.0.

It is affected by light.

Identification (1) Determine the absorption spectrum of a solution of Dihydrocodeine Phosphate (1 in 10,000) as directed under Ultraviolet-visible Spectrophotometry <2.24>, and compare the spectrum with the Reference Spectrum: both spectra exhibit similar intensities of absorption at the same wavelengths.

(2) Determine the infrared spectrum of Dihydrocodeine Phosphate, previously dried, as directed in the potassium bromide disk method under Infrared Spectrophotometry <2.25>, and compare the spectrum with the Reference Spectrum: both spectra exhibit similar intensities of absorption at the same wave numbers.

(3) A solution of Dihydrocodeine Phosphate (1 in 20) responds to Qualitative Tests <1.09> (1) for phosphate.

Purity (1) Chloride <1.03>—Perform the test with 0.5 g of Dihydrocodeine Phosphate. Prepare the control solution with 0.30 mL of 0.01 mol/L hydrochloric acid VS (not more than 0.021%).

(2) Sulfate <1.14>—Perform the test with 0.20 g of Dihydrocodeine Phosphate. Prepare the control solution with 1.0 mL of 0.005 mol/L sulfuric acid VS (not more than 0.240%).

(3) Related substances—Dissolve 0.20 g of Dihydrocodeine Phosphate in 10 mL of diluted ethanol (1 in 2), and use this solution as the sample solution. Pipet 1 mL of the sample solution, add diluted ethanol (1 in 2) to make exactly 50 mL, and use this solution as the standard solution. Perform the test with these solutions as directed under Thin-layer Chromatography <2.03>. Spot 10 μ L of the sample solution and standard solution on a plate of silica gel with fluorescent indicator for thin-chromatography. Develop the plate with a mixture of ethanol (99.5), toluene, acetone and

ammonia solution (28) (14:14:7:1) to a distance of about 15 cm, and air-dry the plate. Examine under ultraviolet light (main wavelength: 254 nm): the spots other than the principal spot obtained from the sample solution are not more intense than the spot from the standard solution.

Loss on drying <2.41> Not more than 1.0% (0.5 g, 105°C, 4 hours).

Assay Weigh accurately about 0.5 g of Dihydrocodeine Phosphate, dissolve in 70 mL of acetic acid (100), and titrate <2.50> with 0.1 mol/L perchloric acid VS until the color of the solution changes from purple through blue to greenish blue (indicator: 3 drops of crystal violet TS). Perform a blank determination in the same manner, and make any necessary correction.

Each mL of 0.1 mol/L perchloric acid VS

= 39.94 mg of $C_{18}H_{23}NO_3 \cdot H_3PO_4$

Containers and storage Containers—Tight containers.

Storage—Light-resistant.

1% Dihydrocodeine Phosphate Powder

ジヒドロコデインリン酸塩散 1%

1% Dihydrocodeine Phosphate Powder contains not less than 0.90% and not more than 1.10% of dihydrocodeine phosphate ($C_{18}H_{23}NO_3 \cdot H_3PO_4$: 399.38).

Method of preparation

Dihydrocodeine Phosphate	10 g
Lactose Hydrate	a sufficient quantity
	To make 1000 g

Prepare as directed under Granules or Powders, with the above ingredients.

Identification Determine the absorption spectrum of a solution of 1% Dihydrocodeine Phosphate Powder (1 in 100) as directed under Ultraviolet-visible Spectrophotometry <2.24>: it exhibits a maximum between 281 nm and 285 nm.

Dissolution <6.10> When the test is performed at 50 revolutions per minute according to the Paddle method, using 900 mL of water as the dissolution medium, the dissolution rate in 15 minutes of 1% Dihydrocodeine Phosphate Powder is not less than 85%.

Start the test with about 1 g of 1% Dihydrocodeine Phosphate Powder, accurately weighed, withdraw not less than 20 mL of the medium at the specified minute after starting the test, and filter through a membrane filter with a pore size not exceeding 0.45 μ m. Discard not less than 5 mL of the first filtrate, and use the subsequent filtrate as the sample solution. Separately, weigh accurately about 50 mg of dihydrocodeine phosphate for assay (separately determine the loss on drying <2.41> at 105°C for 4 hours), and dissolve in water to make exactly 100 mL. Pipet 2 mL of this solution, add water to make exactly 100 mL, and use this solution as the standard solution. Perform the test with exactly 20 μ L each of the sample solution and standard solution as directed under Liquid Chromatography <2.01> according to the following conditions, and determine the peak areas, A_T and A_S , of dihydrocodeine in each solution.

Dissolution rate (%) with respect to the labeled amount of dihydrocodeine phosphate ($C_{18}H_{23}NO_3 \cdot H_3PO_4$)
 $= M_S/M_T \times A_T/A_S \times 9/5$

M_S : Amount (mg) of dihydrocodeine phosphate for assay taken, calculated on the dried basis

M_T : Amount (g) of 1% Dihydrocodeine Phosphate Powder taken

Operating conditions—

Proceed as directed in the operating conditions in the Assay.

System suitability—

System performance: When the procedure is run with 20 μ L of the standard solution under the above operating conditions, the number of theoretical plates and the symmetry factor of the peak of dihydrocodeine are not less than 3000 and not more than 2.0, respectively.

System repeatability: When the test is repeated 6 times with 20 μ L of the standard solution under the above operating conditions, the relative standard deviation of the peak area of dihydrocodeine is not more than 2.0%.

Assay Weigh accurately about 5 g of 1% Dihydrocodeine Phosphate Powder, dissolve in water to make exactly 100 mL, then pipet 10 mL of this solution, add exactly 10 mL of the internal standard solution, and use this solution as the sample solution. Separately, weigh accurately about 50 mg of dihydrocodeine phosphate for assay (separately determine the loss on drying <2.41> at 105°C for 4 hours), dissolve in water to make exactly 100 mL, then pipet 10 mL of this solution, add exactly 10 mL of the internal standard solution, and use this solution as the standard solution. Perform the test with 20 μ L each of the sample solution and standard solution as directed under Liquid Chromatography <2.01> according to the following conditions, and calculate the ratios, Q_T and Q_S , of the peak area of dihydrocodeine to that of the internal standard.

$$\begin{aligned} &\text{Amount (mg) of dihydrocodeine phosphate} \\ &(C_{18}H_{23}NO_3 \cdot H_3PO_4) \\ &= M_S \times Q_T/Q_S \end{aligned}$$

M_S : Amount (mg) of dihydrocodeine phosphate for assay taken, calculated on the dried basis

Internal standard solution—A solution of ethylefuran hydrochloride (3 in 10,000).

Operating conditions—

Detector: An ultraviolet absorption photometer (wavelength: 280 nm).

Column: A stainless steel column 4.6 mm in inside diameter and 15 cm in length, packed with octadecylsilanized silica gel for liquid chromatography (5 μ m in particle diameter).

Column temperature: A constant temperature of about 40°C.

Mobile phase: Dissolve 1.0 g of sodium lauryl sulfate in 500 mL of diluted phosphoric acid (1 in 1000), and adjust the pH to 3.0 with sodium hydroxide TS. To 240 mL of this solution add 70 mL of tetrahydrofuran.

Flow rate: Adjust so that the retention time of dihydrocodeine is about 9 minutes.

System suitability—

System performance: When the procedure is run with 20 μ L of the standard solution under the above operating conditions, dihydrocodeine and the internal standard are eluted in this order with the resolution between these peaks being not less than 4.

System repeatability: When the test is repeated 5 times with 20 μ L of the standard solution under the above operat-

ing conditions, the relative standard deviation of the ratios of the peak area of dihydrocodeine to that of the internal standard is not more than 1.0%.

Containers and storage Containers—Tight containers.

10% Dihydrocodeine Phosphate Powder

ジヒドロコデインリン酸塩散 10%

10% Dihydrocodeine Phosphate Powder contains not less than 9.3% and not more than 10.7% of dihydrocodeine phosphate ($C_{18}H_{23}NO_3 \cdot H_3PO_4$; 399.38).

Method of preparation

Dihydrocodeine Phosphate	100 g
Lactose Hydrate	a sufficient quantity
	To make 1000 g

Prepare as directed under Powders, with the above ingredients.

Identification Determine the absorption spectrum of a solution of 10% Dihydrocodeine Phosphate Powder (1 in 1000) as directed under Ultraviolet-visible Spectrophotometry <2.24>: it exhibits a maximum between 281 nm and 285 nm.

Dissolution <6.10> When the test is performed at 50 revolutions per minute according to the Paddle method, using 900 mL of water as the dissolution medium, the dissolution rate in 15 minutes of 10% Dihydrocodeine Phosphate Powder is not less than 85%.

Start the test with about 0.1 g of 10% Dihydrocodeine Phosphate Powder, accurately weighed, withdraw not less than 10 mL of the medium at the specified minute after starting the test, and filter through a membrane filter with a pore size not exceeding 0.45 μ m. Discard not less than 5 mL of the first filtrate, and use the subsequent filtrate as the sample solution. Separately, weigh accurately about 22 mg of dihydrocodeine phosphate for assay (separately determine the loss on drying <2.41> at 105°C for 4 hours), and dissolve in water to make exactly 100 mL. Pipet 5 mL of this solution, add water to make exactly 100 mL, and use this solution as the standard solution. Perform the test with exactly 50 μ L each of the sample solution and standard solution as directed under Liquid Chromatography <2.01> according to the following conditions, and determine the peak areas, A_T and A_S , of dihydrocodeine in each solution.

$$\begin{aligned} &\text{Dissolution rate (\%)} \text{ with respect to the labeled amount} \\ &\text{of dihydrocodeine phosphate } (C_{18}H_{23}NO_3 \cdot H_3PO_4) \\ &= M_S/M_T \times A_T/A_S \times 9/20 \end{aligned}$$

M_S : Amount (mg) of dihydrocodeine phosphate for assay taken, calculated on the dried basis

M_T : Amount (g) of 10% Dihydrocodeine Phosphate Powder taken

Operating conditions—

Proceed as directed in the operating conditions in the Assay.

System suitability—

System performance: When the procedure is run with 50 μ L of the standard solution under the above operating conditions, the number of theoretical plates and the symmetry factor of the peak of dihydrocodeine are not less than 3000

and not more than 2.0, respectively.

System repeatability: When the test is repeated 6 times with 50 μL of the standard solution under the above operating conditions, the relative standard deviation of the peak area of dihydrocodeine is not more than 2.0%.

Assay Weigh accurately about 2.5 g of 10% Dihydrocodeine Phosphate Powder, dissolve in water to make exactly 100 mL, then pipet 2 mL of this solution, add exactly 10 mL of the internal standard solution and water to make 20 mL, and use this solution as the sample solution. Separately, weigh accurately about 50 mg of dihydrocodeine phosphate for assay, (separately determine the loss on drying <2.41> at 105°C for 4 hours), dissolve in water to make exactly 100 mL, then pipet 10 mL of this solution, add exactly 10 mL of the internal standard solution, and use this solution as the standard solution. Perform the test with 20 μL each of the sample solution and standard solution as directed under Liquid Chromatography <2.01> according to the following conditions, and calculate the ratios, Q_T and Q_S , of the peak area of dihydrocodeine to that of the internal standard.

$$\begin{aligned} &\text{Amount (mg) of dihydrocodeine phosphate} \\ &(\text{C}_{18}\text{H}_{23}\text{NO}_3 \cdot \text{H}_3\text{PO}_4) \\ &= M_S \times Q_T / Q_S \times 5 \end{aligned}$$

M_S : Amount (mg) of dihydrocodeine phosphate for assay taken, calculated on the dried basis

Internal standard solution—A solution of ethylefrine hydrochloride (3 in 10,000).

Operating conditions—

Detector: An ultraviolet absorption photometer (wavelength: 280 nm).

Column: A stainless steel column 4.6 mm in inside diameter and 15 cm in length, packed with octadecylsilanized silica gel for liquid chromatography (5 μm in particle diameter).

Column temperature: A constant temperature of about 40°C.

Mobile phase: Dissolve 1.0 g of sodium lauryl sulfate in 500 mL of diluted phosphoric acid (1 in 1000), and adjust the pH to 3.0 with sodium hydroxide TS. To 240 mL of this solution add 70 mL of tetrahydrofuran.

Flow rate: Adjust so that the retention time of dihydrocodeine is about 9 minutes.

System suitability—

System performance: When the procedure is run with 20 μL of the standard solution under the above operating conditions, dihydrocodeine and the internal standard are eluted in this order with the resolution between these peaks being not less than 4.

System repeatability: When the test is repeated 5 times with 20 μL of the standard solution under the above operating conditions, the relative standard deviation of the ratios of the peak area of dihydrocodeine to that of the internal standard is not more than 1.0%.

Containers and storage Containers—Tight containers.

Dihydroergotamine Mesilate

ジヒドロエルゴタミンメシル酸塩

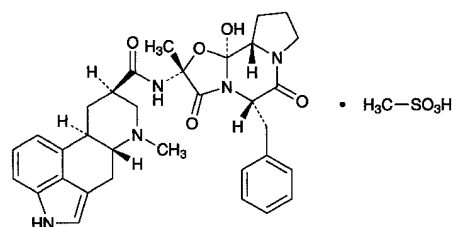

$\text{C}_{33}\text{H}_{37}\text{N}_5\text{O}_5 \cdot \text{CH}_4\text{O}_3\text{S}$: 679.78
(5'S,10R)-5'-Benzyl-12'-hydroxy-2'-methyl-9,10-dihydroergotaman-3',6',18-trione monomethanesulfonate
[6190-39-2]

Dihydroergotamine Mesilate contains not less than 97.0% of dihydroergotamine mesilate ($\text{C}_{33}\text{H}_{37}\text{N}_5\text{O}_5 \cdot \text{CH}_4\text{O}_3\text{S}$), calculated on the dried basis.

Description Dihydroergotamine Mesilate occurs as a white to yellowish white or grayish white to reddish white powder.

It is freely soluble in acetic acid (100), sparingly soluble in methanol and in chloroform, slightly soluble in water and in ethanol (95), and practically insoluble in acetic anhydride and in diethyl ether.

It is gradually colored by light.

Melting point: about 214°C (with decomposition).

Identification (1) Dissolve 1 mg of Dihydroergotamine Mesilate in 5 mL of a solution of L-tartaric acid (1 in 100). To 1 mL of this solution add 2 mL of 4-dimethylaminobenzaldehyde-ferric chloride TS, and shake: a blue color develops.

(2) To 0.1 g of Dihydroergotamine Mesilate add 0.4 g of sodium hydroxide, stir well, and incinerate by gradual ignition. After cooling, add 10 mL of water to the residue, heat to boiling, cool, and filter. To the filtrate add 0.5 mL of hydrochloric acid: the solution responds to Qualitative Tests <1.09> for sulfate. Separately, to 0.1 g of Dihydroergotamine Mesilate add 5 mL of dilute hydrochloric acid, shake for 5 minutes, filter, and to the filtrate add 1 mL of barium chloride TS: the solution is clear.

(3) Determine the absorption spectrum of a solution of Dihydroergotamine Mesilate in methanol (1 in 20,000) as directed under Ultraviolet-visible Spectrophotometry <2.24>, and compare the spectrum with the Reference Spectrum: both spectra exhibit similar intensities of absorption at the same wavelengths.

(4) Determine the infrared absorption spectrum of Dihydroergotamine Mesilate, previously dried, as directed in the potassium bromide disk method under Infrared Spectrophotometry <2.25>, and compare the spectrum with the Reference Spectrum: both spectra exhibit similar intensities of absorption at the same wave numbers.

Optical rotation <2.49> $[\alpha]_D^{20}$: $-16.7 - -22.7^\circ$ [0.5 g, calculated on the dried basis, a mixture of ethanol (99.5), chloroform and ammonia solution (28) (10:10:1), 20 mL, 100 mm].

pH <2.54> Dissolve 0.05 g of Dihydroergotamine Mesilate in 50 mL of water: the pH of this solution is between 4.4 and 5.4.

Purity (1) Clarity and color of solution—Dissolve 0.10 g of Dihydroergotamine Mesilate in 0.1 mL of a solution of

methanesulfonic acid (7 in 100) and 50 mL of water: the solution is clear, and has no more color than the following control solutions [1] or [2].

Control solution [1]: Pipet 0.6 mL of Iron (III) Chloride CS and 0.15 mL of Cobalt (II) Chloride CS, mix, and add diluted hydrochloric acid (1 in 40) to make exactly 100 mL.

Control solution [2]: Pipet 0.6 mL of Iron (III) Chloride CS, 0.25 mL of Cobalt (II) Chloride CS and 0.1 mL of Copper (II) Sulfate CS, mix, and add diluted hydrochloric acid (1 in 40) to make exactly 100 mL.

(2) Related substances—Conduct this procedure without exposure to light, using light-resistant vessels. Dissolve 0.10 g of Dihydroergotamine Mesilate in 5 mL of a mixture of chloroform and methanol (9:1), and use this solution as the sample solution. Pipet 1 mL of the sample solution, add a mixture of chloroform and methanol (9:1) to make exactly 200 mL, and use this solution as the standard solution (1). Pipet 10 mL of the standard solution (1), add a mixture of chloroform and methanol (9:1) to make exactly 25 mL, and use this solution as the standard solution (2). Perform the test with these solutions as directed under Thin-layer Chromatography <2.03>. Spot 5 μ L each of the sample solution and standard solutions (1) and (2) on a plate of silica gel for thin-layer chromatography. Develop the plate with a mixture of dichloromethane, ethyl acetate, methanol and ammonia solution (28) (50:50:6:1) to a distance of about 15 cm, and dry the plate with cold wind within 1 minute. Develop the plate again immediately with a freshly prepared mixture of dichloromethane, ethyl acetate, methanol and ammonia solution (28) (50:50:6:1) to a distance of about 15 cm, and air-dry the plate. Spray evenly 4-dimethylaminobenzaldehyde TS for spraying on the plate, and dry the plate with warm wind: the spots other than the principal spot obtained from the sample solution are not more intense than the spot from the standard solution (1), and the spots, which are more intense than the spot from the standard solution (2), are not more than two.

Loss on drying <2.41> Not more than 4.0% (0.5 g, in vacuum at a pressure not exceeding 0.67 kPa, 100°C, 6 hours).

Assay Weigh accurately about 0.2 g of Dihydroergotamine Mesilate, dissolve in 170 mL of a mixture of acetic anhydride and acetic acid (100) (10:1), and titrate <2.50> with 0.02 mol/L perchloric acid VS (potentiometric titration). Perform a blank determination in the same manner, and make any necessary correction.

Each mL of 0.02 mol/L perchloric acid VS
= 13.60 mg of $C_{33}H_{37}N_5O_5 \cdot CH_4O_3S$

Containers and storage Containers—Tight containers.
Storage—Light-resistant.

Dihydroergotoxine Mesilate

ジヒドロエルゴトキシンメシル酸塩

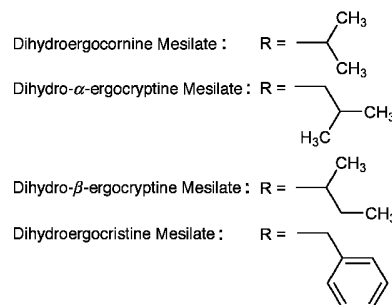
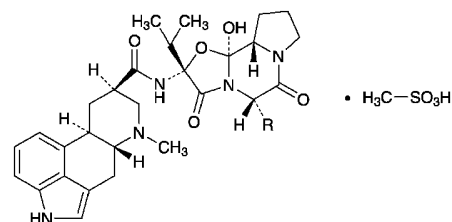

Dihydroergocornine Mesilate

$C_{31}H_{41}N_5O_5 \cdot CH_4O_3S$: 659.79
(5'S,10R)-12'-Hydroxy-2',5'-bis(1-methylethyl)-9,10-dihydroergotaman-3',6',18-trione monomethanesulfonate

Dihydro- α -ergocryptine Mesilate

$C_{32}H_{43}N_5O_5 \cdot CH_4O_3S$: 673.82
(5'S,10R)-12'-Hydroxy-2'-(1-methylethyl)-5'-(2-methylpropyl)-9,10-dihydroergotaman-3',6',18-trione monomethanesulfonate

Dihydro- β -ergocryptine Mesilate

$C_{32}H_{43}N_5O_5 \cdot CH_4O_3S$: 673.82
(5'S,10R)-12'-Hydroxy-2'-(1-methylethyl)-5'-(1-methylpropyl)-9,10-dihydroergotaman-3',6',18-trione monomethanesulfonate

Dihydroergocristine Mesilate

$C_{35}H_{41}N_5O_5 \cdot CH_4O_3S$: 707.84
(5'S,10R)-5'-Benzyl-12'-hydroxy-2'-(1-methylethyl)-9,10-dihydroergotaman-3',6',18-trione monomethanesulfonate

[8067-24-1, Dihydroergotoxine Mesilate]

Dihydroergotoxine Mesilate contains not less than 97.0% and not more than 103.0% of dihydroergotoxine mesilate [as a mixture of dihydroergocornine mesilate ($C_{31}H_{41}N_5O_5 \cdot CH_4O_3S$), dihydro- α -ergocryptine mesilate ($C_{32}H_{43}N_5O_5 \cdot CH_4O_3S$), dihydro- β -ergocryptine mesilate ($C_{32}H_{43}N_5O_5 \cdot CH_4O_3S$) and dihydroergocristine mesilate ($C_{35}H_{41}N_5O_5 \cdot CH_4O_3S$)], calculated on the anhydrous basis. The relative contents of dihydroergocornine mesilate ($C_{31}H_{41}N_5O_5 \cdot CH_4O_3S$), dihydroergocryptine mesilate ($C_{32}H_{43}N_5O_5 \cdot CH_4O_3S$) and dihydroergocristine mesilate ($C_{35}H_{41}N_5O_5 \cdot CH_4O_3S$) are 30.3–36.3% each, and the content ratio of dihydro- α -ergocryptine mesilate and dihydro- β -ergocryptine mesilate is 1.5–2.5:1.

Description Dihydroergotoxine Mesilate occurs as a white to pale yellow powder.

It is soluble in methanol, sparingly soluble in ethanol (95), slightly soluble in water, in acetonitrile and in chloroform, and practically insoluble in diethyl ether.

Identification Determine the infrared absorption spectrum of Dihydroergotoxine Mesilate as directed in the potassium bromide disk method under Infrared Spectrophotometry <2.25>, and compare the spectrum with the Reference Spectrum: both spectra exhibit similar intensities of absorption at the same wave numbers.

Optical rotation <2.49> $[\alpha]_D^{20}$: +11.0 – +15.0° (0.2 g calculated on the anhydrous basis, dilute ethanol, 20 mL, 100 mm).

Purity (1) Clarity and color of solution—Dissolve 0.10 g of Dihydroergotoxine Mesilate in 20 mL of water: the solution is clear and the color of the solution is not more intense than that of the following control solution.

Control solution: To a mixture of 1.0 mL of Cobalt (II) Chloride CS, 0.4 mL of Copper (II) Sulfate CS and 2.4 mL of Iron (III) Chloride CS add diluted hydrochloric acid (1 in 40) to make exactly 200 mL.

(2) Heavy metals <1.07>—Proceed with 1.0 g of Dihydroergotoxine Mesilate according to Method 2, and perform the test. Prepare the control solution with 2.0 mL of Standard Lead Solution (not more than 20 ppm).

(3) Related substances—Weigh accurately 0.100 g of Dihydroergotoxine Mesilate, dissolve it in a mixture of chloroform and methanol (9:1) to make exactly 5 mL, and use this solution as the sample solution. Separately, weigh accurately 10 mg of dihydroergocristine mesilate for thin-layer chromatography, and dissolve in a mixture of chloroform and methanol (9:1) to make exactly 100 mL. Pipet 6 mL, 4 mL and 2 mL of this solution, add a mixture of chloroform and methanol (9:1) to make exactly 10 mL, respectively, and use these solutions as the standard solutions (1), (2) and (3), respectively. Perform the test with these solutions as directed under Thin-layer Chromatography <2.03> without putting the filter paper in the developing vessel. Spot 5 μ L each of the sample solution and the standard solutions (1), (2) and (3) on a plate of silica gel for thin-layer chromatography. Develop the plate with a mixture of dichloromethane, ethyl acetate, methanol and ammonia solution (28) (50:50:3:1) to a distance of about 15 cm, and dry the plate with the aid of a cool air stream. Immediately after that, develop the plate again with a newly prepared mixture of dichloromethane, ethyl acetate, methanol and ammonia solution (28) (50:50:3:1) to a distance of about 15 cm, and dry the plate within 1 minute with the aid of a cool air stream. Spray evenly *p*-dimethylaminobenzal-dehyde-hydrochloric acid TS on the plate, dry the plate within 2 minutes with the aid of a cool air stream, and heat it at 40°C for 15 minutes: the spots other than the principal spot obtained from the sample solution are not more intense than the spot from the standard solution (1), not more than 2 spots are more intense than that from the standard solution (2), and not more than 4 spots are more intense than that from the standard solution (3).

Water <2.48> Not more than 5.0% (0.2 g, volumetric titration, direct titration).

Residue on ignition <2.44> Not more than 0.1% (1 g).

Assay (1) Dihydroergotoxine mesilate—Weigh accurately about 30 mg each of Dihydroergotoxine Mesilate and Dihydroergotoxine Mesilate RS, and dissolve them separately in a suitable amount of a mixture of water and acetonitrile (3:1). To these solutions add exactly 10 mL of the internal standard solution and an amount of a mixture of water and acetonitrile (3:1) to make 50 mL, and use these solutions as the sample solution and the standard solution. Perform the test with 20 μ L of the sample solution and standard solution

as directed under Liquid Chromatography <2.01> according to the following conditions, and calculate the ratios of the peak areas of dihydroergocornine, dihydro- α -ergocryptine, dihydroergocristine and dihydro- β -ergocryptine to the peak area of the internal standard of these solutions.

$$\begin{aligned} \text{Amount (mg) of dihydroergotoxine mesilate} \\ = M_S \times (Q_{TA} + Q_{TB} + Q_{TC} + Q_{TD}) / \\ (Q_{SA} + Q_{SB} + Q_{SC} + Q_{SD}) \end{aligned}$$

M_S : Amount (mg) of Dihydroergotoxine Mesilate RS taken, calculated on the anhydrous basis

Q_{TA} : Ratio of the peak area of dihydroergocornine to that of the internal standard of the sample solution \times 659.80

Q_{TB} : Ratio of the peak area of dihydro- α -ergocryptine to that of the internal standard of the sample \times 673.83

Q_{TC} : Ratio of the peak area of dihydroergocristine to that of the internal standard of the sample solution \times 707.85

Q_{TD} : Ratio of the peak area of dihydro- β -ergocryptine to that of the internal standard of the sample solution \times 673.83

Q_{SA} : Ratio of the peak area of dihydroergocornine to that of the internal standard of the standard solution \times 659.80

Q_{SB} : Ratio of the peak area of dihydro- α -ergocryptine to that of the internal standard of the standard solution \times 673.83

Q_{SC} : Ratio of the peak area of dihydroergocristine to that of the internal standard of the standard solution \times 707.85

Q_{SD} : Ratio of the peak area of dihydro- β -ergocryptine to that of the internal standard of the standard solution \times 673.83

Internal standard solution—Dissolve 0.04 g of chloramphenicol in a mixture of water and acetonitrile (3:1) to make 250 mL.

Operating conditions—

Detector: An ultraviolet absorption photometer (wavelength: 280 nm).

Column: A stainless steel column 4.6 mm in inside diameter and 15 cm in length, packed with octadecylsilanized silica gel for liquid chromatography (5 μ m in particle diameter).

Column temperature: A constant temperature of about 25°C.

Mobile phase: A mixture of water, acetonitrile and triethylamine (30:10:1).

Flow rate: Adjust so that the retention time of chloramphenicol is about 5 minutes.

System suitability—

System performance: When the procedure is run with 20 μ L of the standard solution under the above operating conditions, the internal standard, dihydroergocornine, dihydro- α -ergocryptine, dihydroergocristine and dihydro- β -ergocryptine are eluted in this order with the resolution between the peaks of dihydro- α -ergocryptine and dihydroergocristine being not less than 1.5.

System repeatability: When the test is repeated 6 times with 20 μ L of the standard solution under the above operating conditions, the relative standard deviation of the ratios of the peak area of dihydroergocornine, dihydro- α -ergocryptine, dihydroergocristine and dihydro- β -ergocryptine to that of the internal standard is not more than 0.5%.

(2) Relative contents of dihydroergocornine mesilate, dihydroergocryptine mesilate and dihydroergocristine mesilate—Calculate the relative amounts of dihydroergocor-

nine mesilate, dihydroergocryptine mesilate (dihydro- α -ergocryptine mesilate and dihydro- β -ergocryptine mesilate) and dihydroergocristine mesilate from the chromatogram obtained in Assay (1) for the sample solution using the following equations:

$$\text{Relative amount (\% of dihydroergocornine mesilate)} \\ = Q_{TA}/(Q_{TA} + Q_{TB} + Q_{TC} + Q_{TD}) \times 100$$

$$\text{Relative amount (\% of dihydroergocryptine mesilate)} \\ = (Q_{TB} + Q_{TD})/(Q_{TA} + Q_{TB} + Q_{TC} + Q_{TD}) \times 100$$

$$\text{Relative amount (\% of dihydroergocristine mesilate)} \\ = Q_{TC}/(Q_{TA} + Q_{TB} + Q_{TC} + Q_{TD}) \times 100$$

(3) Ratio of the content of dihydro- α -ergocryptine mesilate to dihydro- β -ergocryptine mesilate—Calculate the ratio of the amount of dihydro- α -ergocryptine mesilate to dihydro- β -ergocryptine mesilate from the chromatogram obtained in the Assay (1) for the sample solution using the following equations:

$$\text{Ratio of the content of dihydro-}\alpha\text{-ergocryptine} \\ \text{mesilate to dihydro-}\beta\text{-ergocryptine mesilate} \\ = Q_{TB}/Q_{TD}$$

Containers and storage Containers—Well-closed containers.

Storage—Light-resistant.

Dilazep Hydrochloride Hydrate

ジラゼブ塩酸塩水和物

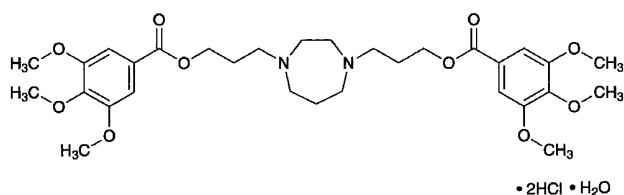

$C_{31}H_{44}N_2O_{10} \cdot 2HCl \cdot H_2O$: 695.63
3,3'-(1,4-Diazepane-1,4-diyl)dipropyl
bis(3,4,5-trimethoxybenzoate) dihydrochloride
monohydrate
[20153-98-4, anhydride]

Dilazep Hydrochloride Hydrate contains not less than 98.0% of dilazep hydrochloride ($C_{31}H_{44}N_2O_{10} \cdot 2HCl$: 677.62), calculated on the dried basis.

Description Dilazep Hydrochloride Hydrate occurs as a white crystalline powder. It is odorless.

It is freely soluble in acetic acid (100) and in chloroform, soluble in water, slightly soluble in ethanol (95) and in acetic anhydride, and practically insoluble in diethyl ether.

Melting point: 200 – 204°C Immerse the sample in a bath of 110°C, and raise the temperature at the rate of about 3°C per minute from 140°C to 150°C, about 10°C per minute from 160°C to 195°C and about 1°C per minute from 195°C.

Identification (1) To 1 mL of a solution of Dilazep Hydrochloride Hydrate (1 in 100) add 0.1 mL of a solution of hydroxylammonium chloride (1 in 10) and 0.1 mL of 8 mol/L potassium hydroxide TS, and warm in a water bath of 70°C for 10 minutes. After cooling, add 0.5 mL of dilute hydrochloric acid and 0.1 mL of iron (III) chloride TS: a purple color develops.

(2) To 5 mL of a solution of Dilazep Hydrochloride Hydrate (3 in 500) add 0.3 mL of Reinecke salt TS: a light red precipitate is formed.

(3) Determine the absorption spectrum of a solution of Dilazep Hydrochloride Hydrate (1 in 50,000) as directed under Ultraviolet-visible Spectrophotometry <2.24>, and compare the spectrum with the Reference Spectrum: both spectra exhibit similar intensities of absorption at the same wavelengths.

(4) Determine the infrared absorption spectrum of Dilazep Hydrochloride Hydrate as directed in the potassium chloride disk method under Infrared Spectrophotometry <2.25>, and compare the spectrum with the Reference Spectrum: both spectra exhibit similar intensities of absorption at the same wave numbers.

pH <2.54> Dissolve 1.0 g of Dilazep Hydrochloride Hydrate in 100 mL of water: the pH of this solution is between 3.0 and 4.0.

Purity (1) Clarity and color of solution—Dissolve 1.0 g of Dilazep Hydrochloride Hydrate in 20 mL of water: the solution is clear and colorless.

(2) Sulfate <1.14>—Perform the test with 0.5 g of Dilazep Hydrochloride Hydrate. Prepare the control solution with 0.50 mL of 0.005 mol/L sulfuric acid VS (not more than 0.048%).

(3) Heavy metals <1.07>—Proceed with 2.0 g of Dilazep Hydrochloride Hydrate according to Method 1, and perform the test. Prepare the control solution with 2.0 mL of Standard Lead Solution (not more than 10 ppm).

(4) Arsenic <1.11>—Prepare the test solution with 1.0 g of Dilazep Hydrochloride Hydrate according to Method 3, and perform the test (not more than 2 ppm).

(5) Related substances—Dissolve 0.40 g of Dilazep Hydrochloride Hydrate in 10 mL of chloroform, and use this solution as the sample solution. Pipet 1 mL of the sample solution, add chloroform to make exactly 200 mL, and use this solution as the standard solution. Perform the test with these solutions as directed under Thin-layer Chromatography <2.03>. Spot 5 μ L each of the sample solution and standard solution on a plate of silica gel for thin-layer chromatography. Develop the plate with a mixture of methanol, ethyl acetate, dichloromethane and hydrochloric acid (500:200:100:1) to a distance of about 10 cm, and air-dry the plate. Spray evenly Dragendorff's TS for spraying on the plate: the spots other than the principal spot obtained from the sample solution are not more intense than the spot from the standard solution.

Loss on drying <2.41> 2.0 – 3.0% (1 g, 105°C, 3 hours).

Residue on ignition <2.44> Not more than 0.1% (1 g).

Assay Weigh accurately about 0.3 g of Dilazep Hydrochloride Hydrate, dissolve in 40 mL of a mixture of acetic anhydride and acetic acid (100) (7:3), and titrate <2.50> with 0.1 mol/L perchloric acid VS (potentiometric titration). Perform a blank determination in the same manner, and make any necessary correction.

$$\text{Each mL of 0.1 mol/L perchloric acid VS} \\ = 33.88 \text{ mg of } C_{31}H_{44}N_2O_{10} \cdot 2HCl$$

Containers and storage Containers—Tight containers.

Diltiazem Hydrochloride

ジルチアゼム塩酸塩

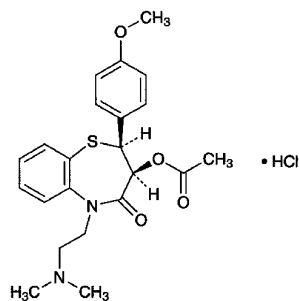

$C_{22}H_{26}N_2O_4S \cdot HCl$: 450.98

(2*S*,3*S*)-5-[2-(Dimethylamino)ethyl]-2-(4-methoxyphenyl)-4-oxo-2,3,4,5-tetrahydro-1,5-benzothiazepin-3-yl acetate monohydrochloride
[33286-22-5]

Diltiazem Hydrochloride, when dried, contains not less than 98.5% of diltiazem hydrochloride ($C_{22}H_{26}N_2O_4S \cdot HCl$).

Description Diltiazem Hydrochloride occurs as white, crystals or crystalline powder. It is odorless.

It is very soluble in formic acid, freely soluble in water, in methanol and in chloroform, sparingly soluble in acetonitrile, slightly soluble in acetic anhydride and in ethanol (99.5), and practically insoluble in diethyl ether.

Identification (1) Dissolve 0.05 g of Diltiazem Hydrochloride in 1 mL of 1 mol/L hydrochloric acid TS, add 2 mL of ammonium thiocyanate-cobalt (II) nitrate TS and 5 mL of chloroform, shake well, and allow to stand: a blue color develops in the chloroform layer.

(2) Proceed as directed under Oxygen Flask Combustion Method <1.06> with 0.03 g of Diltiazem Hydrochloride, using 20 mL of water as the absorbing liquid, and prepare the test solution: the test solution responds to Qualitative Tests <1.09> (1) for sulfate.

(3) Dissolve 0.01 g of Diltiazem Hydrochloride in 0.01 mol/L hydrochloric acid TS to make 100 mL. To 2 mL of the solution add 0.01 mol/L hydrochloric acid TS to make 20 mL. Determine the absorption spectrum of the solution as directed under Ultraviolet-visible Spectrophotometry <2.24>, and compare the spectrum with the Reference Spectrum: both spectra exhibit similar intensities of absorption at the same wavelengths.

(4) Determine the infrared absorption spectrum of Diltiazem Hydrochloride, previously dried, as directed in the potassium bromide disk method under Infrared Spectrophotometry <2.25>: it exhibits absorption at the wave numbers of about 1741 cm^{-1} , 1678 cm^{-1} , 1252 cm^{-1} and 1025 cm^{-1} .

(5) A solution of Diltiazem Hydrochloride (1 in 50) responds to Qualitative Tests <1.09> (2) for chloride.

Optical rotation <2.49> $[\alpha]_D^{20}$: +115 – +120° (after drying, 0.20 g, water, 20 mL, 100 mm).

Melting point <2.60> 210 – 215°C (with decomposition).

pH <2.54> Dissolve 1.0 g of Diltiazem Hydrochloride in 100 mL of water: the pH of this solution is between 4.3 and 5.3.

Purity (1) Clarity and color of solution—Dissolve 1.0 g of Diltiazem Hydrochloride in 20 mL of water: the solution

is clear and colorless.

(2) Sulfate <1.14>—Perform the test with 1.0 g of Diltiazem Hydrochloride. Prepare the control solution with 0.50 mL of 0.005 mol/L sulfuric acid VS (not more than 0.024%).

(3) Heavy metals <1.07>—Proceed with 2.0 g of Diltiazem Hydrochloride according to Method 2, and perform the test. Prepare the control solution with 2.0 mL of Standard Lead Solution (not more than 10 ppm).

(4) Arsenic <1.11>—Place 1.0 g of Diltiazem Hydrochloride in a decomposition flask, add 5 mL of nitric acid and 2 mL of sulfuric acid, put a small funnel on the neck of the flask, and heat cautiously until white fumes are evolved. After cooling, add 2 mL of nitric acid, heat, and repeat this procedure twice, add several 2-mL portions of hydrogen peroxide (30), and heat until the solution becomes colorless to pale yellow. After cooling, add 2 mL of saturated solution of ammonium oxalate monohydrate, and heat again until white fumes are evolved. After cooling, add water to make 5 mL, use this solution as the test solution, and perform the test: the test solution has no more color than the following control solution (not more than 2 ppm).

Control solution: Proceed in the same manner as the test solution without Diltiazem Hydrochloride, add 2.0 mL of Standard Arsenic Solution and water to make 5 mL, and proceed in the same manner as the test solution.

(5) Related substances—Dissolve 50 mg of Diltiazem Hydrochloride in 50 mL of diluted ethanol (4 in 5), and use this solution as the sample solution. Measure exactly 1 mL of the sample solution, add diluted ethanol (4 in 5) to make exactly 200 mL, and use this solution as the standard solution. Perform the test with exactly 20 μL each of the sample solution and standard solution as directed under Liquid Chromatography <2.01> according to the following conditions. Determine each peak area of both solutions by automatic integration method: the total area of peaks other than the peak of diltiazem obtained from the sample solution is not larger than 3/5 times the peak area of diltiazem from the standard solution.

Operating conditions—

Detector: An ultraviolet absorption photometer (wavelength: 240 nm).

Column: A stainless steel column 4.6 mm in inside diameter and 15 cm in length, packed with octadecylsilanized silica gel for liquid chromatography (5 μm in particle diameter).

Column temperature: A constant temperature of about 50°C.

Mobile phase: Dissolve 8 g of sodium acetate trihydrate and 1.5 g of *d*-camphorsulfonic acid in 500 mL of water, and filter using a membrane filter (0.4 μm in pore size). Add 250 mL each of acetonitrile and methanol to the filtrate.

Flow rate: Adjust so that the retention time of diltiazem is about 9 minutes.

Time span of measurement: About twice as long as the retention time of diltiazem, beginning after the solvent peak.

System suitability—

Test for required detectability: To exactly 2 mL of the standard solution add diluted ethanol (4 in 5) to make exactly 10 mL. Confirm that the peak area of diltiazem obtained with 20 μL of this solution is equivalent to 15 to 25% of that with 20 μL of the standard solution.

System performance: Dissolve 0.03 g of Diltiazem Hydrochloride, 0.02 g of *d*-3-hydroxy-*cis*-2,3-dihydro-5-[2-(dimethylamino)ethyl]-2-(4-methoxyphenyl)-1,5-benzothiazepin-4-(5*H*)-one hydrochloride (hereinafter referred to as de-acetyl substance) and 0.02 g of phenylbenzoate in 160 mL of ethanol (99.5), and add water to make 200 mL. When the

procedure is run with 20 μL of this solution under the above operating conditions, de-acetyl substance, diltiazem and phenyl benzoate are eluted in this order with the resolutions between the peaks of de-acetyl substance and diltiazem and between the peaks of diltiazem and phenyl benzoate being not less than 2.5, respectively.

System repeatability: When the test is repeated 6 times with 20 μL of the standard solution under the above operating conditions, the relative standard deviation of the peak area of diltiazem is not more than 2.0%.

Loss on drying <2.41> Not more than 0.5% (1 g, 105°C, 2 hours).

Residue on ignition <2.44> Not more than 0.1% (1 g).

Assay Weigh accurately about 0.7 g of Diltiazem Hydrochloride, previously dried, dissolve in 2.0 mL of formic acid, add 60 mL of acetic anhydride, and titrate <2.50> with 0.1 mol/L perchloric acid VS (potentiometric titration). Perform a blank determination in the same manner, and make any necessary correction.

Each mL of 0.1 mol/L perchloric acid VS
= 45.10 mg of $\text{C}_{22}\text{H}_{26}\text{N}_2\text{O}_4\text{S}\cdot\text{HCl}$

Containers and storage Containers—Tight containers.
Storage—Light-resistant.

Diltiazem Hydrochloride Extended-release Capsules

ジルチアゼム塩酸塩徐放カプセル

Diltiazem Hydrochloride Extended-release Capsules contain not less than 95.0% and not more than 105.0% of the labeled amount of diltiazem hydrochloride ($\text{C}_{22}\text{H}_{26}\text{N}_2\text{O}_4\text{S}\cdot\text{HCl}$: 450.98).

Method of preparation Prepare as directed under Capsules, with Diltiazem Hydrochloride.

Identification Take out the content of Diltiazem Hydrochloride Extended-release Capsules, and powder. To a portion of the powder, equivalent to 0.1 g of Diltiazem Hydrochloride, add 100 mL of 0.01 mol/L hydrochloric acid TS, shake thoroughly, and filter. To 1 mL of the filtrate add 0.01 mol/L hydrochloric acid TS to make 100 mL, and determine the absorption spectrum of this solution as directed under Ultraviolet-visible Spectrophotometry <2.24>: it exhibits a maximum between 234 nm and 238 nm.

Purity Related substances—Take out the content of Diltiazem Hydrochloride Extended-release Capsules, and powder. To a portion of the powder, equivalent to 50 mg of Diltiazem Hydrochloride, add 30 mL of methanol, shake vigorously for 20 minutes, then add methanol to make 50 mL, filter through a membrane filter with a pore size not exceeding 0.45 μm . Discard the first 10 mL of the filtrate, and use the subsequent filtrate as the sample solution. Pipet 3 mL of the sample solution, add methanol to make exactly 200 mL, and use this solution as the standard solution. Perform the test with exactly 20 μL each of the sample solution and standard solution as directed under Liquid Chromatography <2.01> according to the following conditions, and determine each peak area by the automatic integration method: the total area of the peaks other than diltiazem obtained from the sample solution is not larger than the peak area of diltiazem from the standard solution.

Operating conditions—

Detector, column, column temperature, mobile phase, and flow rate: Proceed as directed in the operating conditions in the Assay.

Time span of measurement: About 2 times as long as the retention time of diltiazem, beginning after the solvent peak.

System suitability—

System performance: Proceed as directed in the system suitability in the Assay.

Test for required detectability: Pipet 2 mL of the standard solution, and add methanol to make exactly 30 mL. Confirm that the peak area of diltiazem obtained with 20 μL of this solution is equivalent to 4.7 to 8.6% of that with 20 μL of the standard solution.

System repeatability: When the test is repeated 6 times with 20 μL of the standard solution under the above operating conditions, the relative standard deviation of the peak area of diltiazem is not more than 2.0%.

Uniformity of dosage units <6.02> Perform the Mass variation test, or the Content uniformity test according to the following method: it meets the requirement.

Take out the content of 1 capsule of Diltiazem Hydrochloride Extended-release Capsules, add $V/2$ mL of methanol, then add exactly $V/10$ mL of the internal standard solution, and shake vigorously for 20 minutes. Add methanol to make V mL so that each mL contains about 1 mg of diltiazem hydrochloride ($\text{C}_{22}\text{H}_{26}\text{N}_2\text{O}_4\text{S}\cdot\text{HCl}$), and filter through a membrane filter with a pore size not exceeding 0.45 μm . Discard the first 5 mL of the filtrate, pipet 3 mL of the subsequent filtrate, add methanol to make 20 mL, and use this solution as the sample solution. Then, proceed as directed in the Assay.

$$\begin{aligned} & \text{Amount (mg) of diltiazem hydrochloride} \\ & (\text{C}_{22}\text{H}_{26}\text{N}_2\text{O}_4\text{S}\cdot\text{HCl}) \\ & = M_S \times Q_T/Q_S \times V/100 \end{aligned}$$

M_S : Amount (mg) of diltiazem hydrochloride for assay taken

Internal standard solution—A solution of phenyl benzoate in methanol (3 in 400).

Dissolution Being specified separately when the drug is granted approval based on the Law.

Assay Take out the content of not less than 20 Diltiazem Hydrochloride Extended-release Capsules, weigh the mass of the content accurately, and powder. Weigh accurately a portion of the powder, equivalent to about 0.1 g of diltiazem hydrochloride ($\text{C}_{22}\text{H}_{26}\text{N}_2\text{O}_4\text{S}\cdot\text{HCl}$), add 50 mL of methanol, then add exactly 10 mL of the internal standard solution, shake vigorously for 20 minutes, and add methanol to make 100 mL. Filter this solution through a membrane filter with a pore size not exceeding 0.45 μm , discard the first 5 mL of the filtrate, to 3 mL of the subsequent filtrate add methanol to make 20 mL, and use this solution as the sample solution. Separately, weigh accurately about 0.1 g of diltiazem hydrochloride for assay, previously dried at 105°C for 2 hours, dissolve in 50 mL of methanol, add exactly 10 mL of the internal standard solution, and add methanol to make 100 mL. To 3 mL of this solution add methanol to make 20 mL, and use this solution as the standard solution. Perform the test with 20 μL each of the sample solution and standard solution as directed under Liquid Chromatography <2.01> according to the following conditions, and calculate the ratios, Q_T and Q_S , of the peak area of diltiazem to that of the internal standard.

$$\begin{aligned} & \text{Amount (mg) of diltiazem hydrochloride} \\ & (\text{C}_{22}\text{H}_{26}\text{N}_2\text{O}_4\text{S}\cdot\text{HCl}) \\ & = M_S \times Q_T/Q_S \end{aligned}$$

M_S : Amount (mg) of diltiazem hydrochloride for assay taken

Internal standard solution—A solution of phenyl benzoate in methanol (3 in 400).

Operating conditions—

Detector: An ultraviolet absorption photometer (wavelength: 240 nm).

Column: A stainless steel column 4.6 mm in inside diameter and 15 cm in length, packed with octadecylsilanized silica gel for liquid chromatography (5 μm in particle diameter).

Column temperature: A constant temperature of about 50°C.

Mobile phase: Dissolve 8 g of sodium acetate trihydrate and 1.5 g of *d*-camphorsulfonic acid in 500 mL of water, and filter through a membrane filter with a pore size not exceeding 0.45 μm . To the filtrate add 250 mL of acetonitrile and 250 mL of methanol.

Flow rate: Adjust so that the retention time of diltiazem is about 9 minutes.

System suitability—

System performance: Dissolve 30 mg of diltiazem hydrochloride, 20 mg of *d*-3-hydroxy-*cis*-2,3-dihydro-5-[2-(dimethylamino)ethyl]-2-(4-methoxyphenyl)-1,5-benzothiazepin-4(5*H*)-on hydrochloride (hereinafter referred to as de-acetyl substance) and 20 mg of phenyl benzoate in methanol to make 200 mL. When the procedure is run with 20 μL of this solution under the above operating conditions, de-acetyl substance, diltiazem and phenyl benzoate are eluted in this order and the resolutions between the peaks of de-acetyl substance and diltiazem and the peaks of diltiazem and phenyl benzoate are not less than 2.5, respectively.

System repeatability: When the test is repeated 6 times with 20 μL of the standard solution under the above operating conditions, the relative standard deviation of the ratio of the peak area of diltiazem to that of the internal standard is not more than 1.0%.

Containers and storage Containers—Tight containers.

Dimemorfan Phosphate

ジメモルファンリン酸塩

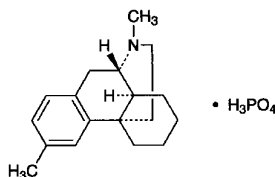

$\text{C}_{18}\text{H}_{25}\text{N}\cdot\text{H}_3\text{PO}_4$: 353.39
(9*S*,13*S*,14*S*)-3,17-Dimethylmorphinan monophosphate
[36304-84-4]

Dimemorfan Phosphate, when dried, contains not less than 98.5% of dimemorfan phosphate ($\text{C}_{18}\text{H}_{25}\text{N}\cdot\text{H}_3\text{PO}_4$).

Description Dimemorfan Phosphate occurs as white to pale yellow-white, crystals or crystalline powder.

It is freely soluble in acetic acid (100), sparingly soluble in water and in methanol, slightly soluble in ethanol (95), and practically insoluble in diethyl ether.

Melting point: about 265°C (with decomposition).

Identification (1) Determine the absorption spectrum of a solution of Dimemorfan Phosphate (1 in 5000) as directed under Ultraviolet-visible Spectrophotometry <2.24>, and compare the spectrum with the Reference Spectrum: both spectra exhibit similar intensities of absorption at the same wavelengths.

(2) Determine the infrared absorption spectrum of Dimemorfan Phosphate, previously dried, as directed in the potassium bromide disk method under Infrared Spectrophotometry <2.25>, and compare the spectrum with the Reference Spectrum: both spectra exhibits similar intensities of absorption at the same wave numbers.

(3) To 2 mL of a solution of Dimemorfan Phosphate (1 in 100) add 2 to 3 drops of silver nitrate TS: a yellow precipitate is formed, and it dissolves on the addition of dilute nitric acid.

Optical rotation <2.49> $[\alpha]_D^{20}$: +25 – +27° (after drying, 1 g, methanol, 100 mL, 100 mm).

pH <2.54> Dissolve 1.0 g of Dimemorfan Phosphate in 100 mL of water: the pH of this solution is between 4.0 and 5.0.

Purity (1) Heavy metals <1.07>—Proceed with 1.0 g of Dimemorfan Phosphate according to Method 1, and perform the test. Prepare the control solution with 2.0 mL of Standard Lead Solution (not more than 20 ppm).

(2) Arsenic <1.11>—Prepare the test solution with 1.0 g of Dimemorfan Phosphate according to Method 3, and perform the test. Use 10 mL of a solution of magnesium nitrate hexahydrate in ethanol (95) (1 in 10) (not more than 2 ppm).

(3) Related substances—Dissolve 0.10 g of Dimemorfan Phosphate in 10 mL of methanol, and use this solution as the sample solution. Pipet 1 mL of the sample solution, add methanol to make exactly 100 mL, and use this solution as the standard solution. Perform the test with these solutions as directed under Thin-layer Chromatography <2.03>. Spot 10 μL each of the sample solution and standard solution on a plate of silica gel for thin-layer chromatography. Develop the plate with a mixture of methanol, chloroform and ammonia solution (28) (150:150:1) to a distance of about 10 cm, and air-dry the plate. Spray evenly the plate with Dragendorff's TS for spraying: the spots other than the principal spot obtained from the sample solution are not more intense than the spot from the standard solution.

Loss on drying <2.41> Not more than 0.5% (1 g, 105°C, 3 hours).

Assay Weigh accurately about 0.6 g of Dimemorfan Phosphate, previously dried, dissolve in 100 mL of acetic acid (100), and titrate <2.50> with 0.1 mol/L perchloric acid VS (potentiometric titration). Perform a blank determination in the same manner, and make any necessary correction.

Each mL of 0.1 mol/L perchloric acid VS
= 35.34 mg of $\text{C}_{18}\text{H}_{25}\text{N}\cdot\text{H}_3\text{PO}_4$

Containers and storage Containers—Tight containers.

Dimenhydrinate

ジメンヒドリナート

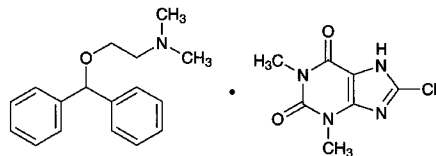

$C_{17}H_{21}NO \cdot C_7H_7ClN_4O_2$: 469.96
 2-(Diphenylmethoxy)-*N,N*-dimethylethylamine—
 8-chloro-1,3-dimethyl-1*H*-purine-2,6(3*H*,7*H*)-dione (1/1)
 [523-87-5]

Dimenhydrinate, when dried, contains not less than 53.0% and not more than 55.5% of diphenhydramine ($C_{17}H_{21}NO$: 255.36), and not less than 44.0% and not more than 47.0% of 8-chlorotheophylline ($C_7H_7ClN_4O_2$: 214.61).

Description Dimenhydrinate occurs as a white crystalline powder. It is odorless, and has a bitter taste.

It is very soluble in chloroform, freely soluble in ethanol (95), and slightly soluble in water and in diethyl ether.

Identification (1) Dissolve 0.5 g of Dimenhydrinate in 30 mL of dilute ethanol, add 30 mL of water, and use this solution as the sample solution. Transfer 30 mL of the sample solution to a separator, and add 2 mL of ammonia solution (28). Extract with two 10-mL portions of diethyl ether, combine the diethyl ether extracts, wash the combined extracts with 5 mL of water, and then extract the combined extracts with 15 mL of diluted hydrochloric acid (1 in 100). With this acid extract perform the following tests.

(i) To 5 mL of this acid extract add 5 drops of Reinecke salt TS: a light red precipitate is produced.

(ii) To 10 mL of this acid extract add 10 mL of 2,4,6-trinitrophenol TS dropwise, and allow to stand for 30 minutes. Collect the precipitate by filtering, recrystallize from dilute ethanol, and dry at 105°C for 30 minutes: the crystals melt <2.60> between 128°C and 133°C.

(2) To 30 mL of the sample solution obtained in (1) add 2 mL of dilute sulfuric acid, and cool for 30 minutes. Scratch the inside wall of the container frequently to facilitate crystallization. Filter, and wash the white crystals with a small amount of ice-cooled water. Dry the crystals for 1 hour at 105°C: the crystals melt <2.60> between 300°C and 305°C with decomposition.

(3) To 0.01 g of the crystals obtained in (2) add 10 drops of hydrogen peroxide TS and 1 drop of hydrochloric acid, and evaporate on a water bath to dryness: the residue shows a yellow-red color. When the dish containing the residue is held over a vessel containing 2 to 3 drops of ammonia TS, the color changes to red-purple, which is discharged on the addition of 2 to 3 drops of sodium hydroxide TS.

(4) Mix well 0.05 g of the crystals obtained in (2) with 0.5 g of sodium peroxide in a nickel crucible, and heat until the mass melts. Cool, dissolve the melted mass in 20 mL of water, and acidify with dilute nitric acid: the solution responds to Qualitative Tests <1.09> for chloride.

Melting point <2.60> 102 – 107°C

Purity (1) Chloride <1.03>—Transfer 50 mL of the filtrate obtained in the Assay (2) to a Nessler tube, add 1 mL of nitric acid, and allow to stand for 5 minutes: the turbidity of the solution is not greater than that of the following control

solution (not more than 0.044%).

Control solution: Dilute 0.25 mL of 0.01 mol/L hydrochloric acid VS with 6 mL of dilute nitric acid and with water to make 50 mL, add 1 mL of silver nitrate TS, and allow to stand for 5 minutes.

(2) Bromide and iodide—Place 0.10 g of Dimenhydrinate in a glass-stoppered test tube, and add 0.05 g of sodium nitrite, 10 mL of chloroform and 10 mL of dilute hydrochloric acid. Stopper, shake well, and allow to stand: the chloroform layer remains colorless.

Loss on drying <2.41> Not more than 0.5% (3 g, in vacuum, phosphorus (V) oxide, 24 hours).

Residue on ignition <2.44> Not more than 0.3% (1 g).

Assay (1) Diphenhydramine—Weigh accurately about 0.5 g of Dimenhydrinate, previously dried, transfer to a 250-mL separator, and add 50 mL of water, 3 mL of ammonia TS and 10 g of sodium chloride. Extract with six 15-mL portions of diethyl ether with shaking, combine the diethyl ether extracts, and wash the combined diethyl ether extracts with three 50-mL portions of water. To the diethyl ether extracts add exactly 25 mL of 0.05 mol/L sulfuric acid VS, and add 25 mL of water. Shake thoroughly, and evaporate the diethyl ether gently. Cool, and titrate the excess sulfuric acid with 0.1 mol/L sodium hydroxide VS (indicator: 3 drops of methyl red TS). Perform a blank determination in the same manner, and make any necessary correction.

Each mL of 0.05 mol/L sulfuric acid VS
 = 25.54 mg $C_{17}H_{21}NO$

(2) 8-Chlorotheophylline—Weigh accurately about 0.8 g of Dimenhydrinate, previously dried, transfer to a 200-mL volumetric flask, add 50 mL of water, 3 mL of ammonia TS and 6 mL of a solution of ammonium nitrate (1 in 10), and heat on a water bath for 5 minutes. Add exactly 25 mL of 0.1 mol/L silver nitrate VS, heat on a water bath for 15 minutes with occasional shaking, cool, and add water to make exactly 200 mL. Allow to stand overnight to settle the precipitate, and filter through a dry filter paper, discarding the first 20 mL of the filtrate. Measure exactly 100 mL of the subsequent filtrate, acidify with nitric acid, add 3 mL of nitric acid, and titrate the excess silver nitrate with 0.1 mol/L ammonium thiocyanate VS (indicator: 2 mL of ammonium iron (III) sulfate TS). Perform a blank determination in the same manner, and make any necessary correction.

Each mL of 0.1 mol/L silver nitrate VS
 = 21.46 mg of $C_7H_7ClN_4O_2$

Containers and storage Containers—Well-closed containers.

Dimenhydrinate Tablets

ジメンヒドリナート錠

Dimenhydrinate Tablets contain not less than 95.0% and not more than 105.0% of the labeled amount of dimenhydrinate ($C_{17}H_{21}NO \cdot C_7H_7ClN_4O_2$: 469.96).

Method of preparation Prepare as directed under Tablets, with Dimenhydrinate.

Identification (1) Triturate a quantity of powdered Dimenhydrinate Tablets, equivalent to 0.5 g of Dimenhydrinate, with 25 mL of warm ethanol (95), and filter.

Dilute the filtrate with 40 mL of water, and filter again. Use the filtrate as the sample solution. Transfer 30 mL of the sample solution to a separator, and proceed as directed in the Identification (1) under Dimenhydrinate.

(2) With 30 mL of the sample solution obtained in (1), proceed as directed in the Identification (2), (3) and (4) under Dimenhydrinate.

Dissolution <6.10> When the test is performed at 50 revolutions per minute according to the Paddle method, using 900 mL of water as the dissolution medium, the dissolution rate in 15 minutes of Dimenhydrinate Tablets is not less than 85%.

Start the test with 1 tablet of Dimenhydrinate Tablets, withdraw not less than 20 mL of the medium at the specified minute after starting the test, and filter through a membrane filter with a pore size not exceeding 0.45 μm . Discard not less than 10 mL of the first filtrate, pipet V mL of the subsequent filtrate, add water to make exactly V' mL so that each mL contains about 28 μg of dimenhydrinate ($\text{C}_{17}\text{H}_{21}\text{NO}\cdot\text{C}_7\text{H}_7\text{ClN}_4\text{O}_2$), and use this solution as the sample solution. Separately, weigh accurately about 28 mg of dimenhydrinate for assay, previously dried in vacuum using phosphorous (V) oxide as the desiccant for 24 hours, and dissolve in water to make exactly 50 mL. Pipet 5 mL of this solution, add water to make exactly 100 mL, and use this solution as the standard solution. Determine the absorbances, A_T and A_S , of the sample solution and standard solution at 276 nm as directed under Ultraviolet-visible Spectrophotometry <2.24>.

Dissolution rate (%) with respect to the labeled amount of dimenhydrinate ($\text{C}_{17}\text{H}_{21}\text{NO}\cdot\text{C}_7\text{H}_7\text{ClN}_4\text{O}_2$)

$$= M_S \times A_T / A_S \times V' / V \times 1 / C \times 90$$

M_S : Amount (mg) of dimenhydrinate for assay taken

C : Labeled amount (mg) of dimenhydrinate ($\text{C}_{17}\text{H}_{21}\text{NO}\cdot\text{C}_7\text{H}_7\text{ClN}_4\text{O}_2$) in 1 tablet

Assay Weigh accurately, and powder not less than 20 Dimenhydrinate Tablets. Weigh accurately a portion of the powder, equivalent to about 0.5 g of dimenhydrinate ($\text{C}_{17}\text{H}_{21}\text{NO}\cdot\text{C}_7\text{H}_7\text{ClN}_4\text{O}_2$), transfer to a flask, add 40 mL of ethanol (95), and heat with swirling on a water bath until the solution just boils. Continue to heat for 30 seconds, and filter through a glass filter (G4). Wash the filter with warm ethanol (95), transfer the filtrate and washings to a flask, and evaporate the ethanol on a water bath to make 5 mL. Add 50 mL of water, 3 mL of ammonia TS and 6 mL of a solution of ammonium nitrate (1 in 10), heat the mixture on a water bath for 5 minutes, add exactly 25 mL of 0.1 mol/L silver nitrate VS, and heat on a water bath for 15 minutes with occasional shaking. Transfer the mixture to a 200-mL volumetric flask, using water to rinse the flask, cool, add water to make exactly 200 mL, and proceed as directed in the Assay (2) under Dimenhydrinate.

$$\begin{aligned} &\text{Each mL of 0.1 mol/L silver nitrate VS} \\ &= 47.00 \text{ mg of } \text{C}_{17}\text{H}_{21}\text{NO}\cdot\text{C}_7\text{H}_7\text{ClN}_4\text{O}_2 \end{aligned}$$

Containers and storage Containers—Well-closed containers.

Dimercaprol

ジメルカプロール

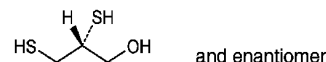

$\text{C}_3\text{H}_8\text{OS}_2$: 124.23
(2*R*,3*S*)-2,3-Disulfanylpropan-1-ol
[59-52-9]

Dimercaprol contains not less than 98.5% and not more than 101.5% of dimercaprol ($\text{C}_3\text{H}_8\text{OS}_2$).

Description Dimercaprol is a colorless or pale yellow liquid. It has a mercaptan-like, disagreeable odor.

It is miscible with methanol and with ethanol (99.5)

It is soluble in peanut oil, and sparingly soluble in water.

It shows no optical rotation.

Identification (1) Add 1 drop of Dimercaprol to a mixture of 1 drop of a solution of cobalt (II) chloride hexahydrate (1 in 200) and 5 mL of water: a yellow-brown color develops.

(2) Determine the infrared absorption spectrum of Dimercaprol as directed in the liquid film method under Infrared Spectrophotometry <2.25>, and compare the spectrum with the Reference Spectrum: both spectra exhibit similar intensities of absorption at the same wave numbers.

Refractive index <2.45> n_D^{20} : 1.570 – 1.575

Specific gravity <2.56> d_{20}^{20} : 1.238 – 1.248

Purity (1) Clarity and color of solution—Dissolve 1.0 mL of Dimercaprol in 20 mL of peanut oil: the solution is clear and colorless to pale yellow.

(2) Bromide—To 2.0 g of Dimercaprol add 25 mL of dilute potassium hydroxide-ethanol TS, and heat in a water bath under a reflux condenser for 2 hours. Evaporate the ethanol in a current of warm air, add 20 mL of water, and cool. Add a mixture of 10 mL of hydrogen peroxide (30) and 40 mL of water, boil gently under a reflux condenser for 10 minutes, and filter rapidly after cooling. Wash the residue with two 10-mL portions of water, combine the washings with the filtrate, add 10 mL of dilute nitric acid and exactly 5 mL of 0.1 mol/L silver nitrate VS, and titrate <2.50> the excess silver nitrate with 0.1 mol/L ammonium thiocyanate VS (indicator: 2 mL of ammonium iron (III) sulfate TS). Perform a blank determination in the same manner: not more than 1.0 mL of 0.1 mol/L silver nitrate VS is consumed.

(3) Heavy metals <1.07>—Proceed with 1.0 g of Dimercaprol according to Method 2, and perform the test. Prepare the control solution with 2.0 mL of Standard Lead Solution (not more than 20 ppm).

Assay Weigh accurately about 0.15 g of Dimercaprol into a glass-stoppered flask, dissolve in 10 mL of methanol, and titrate <2.50> immediately with 0.05 mol/L iodine VS until a pale yellow color is produced. Perform a blank determination in the same manner, and make any necessary correction.

Each mL of 0.05 mol/L iodine VS = 6.212 mg of $\text{C}_3\text{H}_8\text{OS}_2$

Containers and storage Containers—Tight containers.

Storage—Not exceeding 5°C.

Dimercaprol Injection

ジメルカプロール注射液

Dimercaprol Injection is an oily solution for injection.

It contains not less than 95.0% and not more than 105.0% of the labeled amount of dimercaprol ($C_3H_8OS_2$: 124.23).

Method of preparation Prepare as directed under Injections, with Dimercaprol. Benzyl Benzoate or Benzyl Alcohol may be added to increase the solubility.

Description Dimercaprol Injection is a clear, colorless or light yellow liquid. It has an unpleasant odor.

Identification Measure a volume of Dimercaprol Injection, equivalent to 30 mg of Dimercaprol, and proceed as directed in the Identification (1) under Dimercaprol.

Extractable volume <6.05> It meets the requirement.

Foreign insoluble matter <6.06> Perform the test according to Method 1: it meets the requirement.

Insoluble particulate matter <6.07> Perform the test according to Method 2: it meets the requirement.

Sterility <4.06> Perform the test according to the Membrane filtration method: it meets the requirement.

Assay Pipet a volume of Dimercaprol Injection, equivalent to about 0.1 g of dimercaprol ($C_3H_8OS_2$), into a flask, and rinse the pipet several times with a mixture of methanol and diethyl ether (3:1), adding the rinsings to the flask. Add the mixture of methanol and diethyl ether (3:1) to make 50 mL, and titrate <2.50> with 0.05 mol/L iodine VS until a yellow color persists. Perform a blank determination in the same manner, and make any necessary correction.

Each mL of 0.05 mol/L iodine VS
= 6.212 mg of $C_3H_8OS_2$

Containers and storage Containers—Hermetic containers.
Storage—In a cold place.

Dimorpholamine

ジモルホラミン

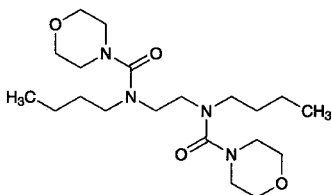

$C_{20}H_{38}N_4O_4$: 398.54
N,N'-(Ethane-1,2-diyl)bis(*N*-butylmorpholine-4-carboxamide)
[119-48-2]

Dimorpholamine, when dried, contains not less than 98.0% and not more than 101.0% of dimorpholamine ($C_{20}H_{38}N_4O_4$).

Description Dimorpholamine is a white to light yellow, crystalline powder, masses or syrupy liquid.

It is very soluble in ethanol (99.5) and in acetic anhydride,

and soluble in water.

The pH of a solution prepared by dissolving 1.0 g of Dimorpholamine in 10 mL of water is between 6.0 and 7.0.

It is hygroscopic.

Identification (1) Determine the absorption spectrum of a solution of Dimorpholamine (1 in 50,000) as directed under Ultraviolet-visible Spectrophotometry <2.24>, and compare the spectrum with the Reference Spectrum: both spectra exhibit similar intensities of absorption at the same wavelengths.

(2) Determine the infrared absorption spectrum of Dimorpholamine, previously dried, as directed in the potassium bromide disk method under the Infrared Spectrophotometry <2.25>, and compare the spectrum with the Reference Spectrum: both spectra exhibit similar intensities of absorption at the same wave numbers.

Purity (1) Clarity and color of solution—Dissolve 1.0 g of Dimorpholamine in 50 mL of water: the solution is clear and colorless to pale yellow.

(2) Chloride <1.03>—To 20 mL of the solution obtained in (1) add 6 mL of dilute nitric acid and water to make 50 mL. Perform the test using this solution as the test solution. Prepare the control solution with 0.40 mL of 0.01 mol/L hydrochloric acid VS (not more than 0.036%).

(3) Sulfate <1.14>—To 10 mL of the solution obtained in (1) add 1 mL of dilute hydrochloric acid and water to make 50 mL. Perform the test using this solution as the test solution. Prepare the control solution with 0.40 mL of 0.005 mol/L sulfuric acid VS (not more than 0.096%).

(4) Heavy metals <1.07>—Proceed with 2.0 g of Dimorpholamine according to Method 2, and perform the test. Prepare the control solution with 2.0 mL of Standard Lead Solution (not more than 10 ppm).

(5) Related substances—Dissolve 0.20 g of Dimorpholamine in 10 mL of ethanol (99.5), and use this solution as the sample solution. Pipet 1 mL of the sample solution, add ethanol (99.5) to make exactly 100 mL, and use this solution as the standard solution. Perform the test with these solutions as directed under Thin-layer Chromatography <2.03>. Spot 10 μ L each of the sample solution and standard solution on a plate of silica gel for thin-layer chromatography. Develop the plate with a mixture of ethanol (99.5) and water (4:1) to a distance of about 10 cm, and air-dry the plate. Allow the plate to stand in iodine vapor for 10 minutes: the spot other than the principal spot obtained from the sample solution is not more intense than the spot from the standard solution.

Loss on drying <2.41> Not more than 0.5% (1 g, in vacuum, phosphorus (V) oxide, 8 hours).

Residue on ignition <2.44> Not more than 0.1% (1 g).

Assay Weigh accurately about 0.6 g of Dimorpholamine, previously dried, dissolve in 50 mL of acetic anhydride, and titrate <2.50> with 0.1 mol/L perchloric acid VS (potentiometric titration). Perform a blank determination in the same manner, and make any necessary correction.

Each mL of 0.1 mol/L perchloric acid VS
= 39.85 mg of $C_{20}H_{38}N_4O_4$

Containers and storage Containers—Tight containers.
Storage—Light-resistant.

Dimorpholamine Injection

ジモルホラミン注射液

Dimorpholamine Injection is an aqueous injection.

It contains not less than 95.0% and not more than 105.0% of the labeled amount of dimorpholamine ($C_{20}H_{38}N_4O_4$; 398.54).

Method of preparation Prepare as directed under Injections, with Dimorpholamine.

Description Dimorpholamine Injection is a clear, colorless liquid.

pH: 3.0 – 5.5

Identification (1) To a volume of Dimorpholamine Injection, equivalent to 0.1 g of Dimorpholamine, add 3 drops of Dragendorff's TS: an orange color develops.

(2) To a volume of Dimorpholamine Injection, equivalent to 50 mg of Dimorpholamine, add 1 mL of dilute hydrochloric acid, and evaporate on a water bath to dryness. Dissolve the residue in 2 mL of hydrochloric acid, boil for 10 minutes under a reflux condenser, and evaporate to dryness on a water bath. Dissolve the residue with 1 mL of water, neutralize with sodium hydroxide TS, and add 0.2 mL of a solution of acetaldehyde (1 in 20), 0.1 mL of sodium pentacyanonitrosyl ferrate (III) TS and 0.5 mL of sodium carbonate TS: a blue color develops.

Bacterial endotoxins <4.01> Less than 5.0 EU/mg. Perform the test with the sample diluted to 0.15 w/v% with water for bacterial endotoxins test.

Extractable volume <6.05> It meets the requirement.

Foreign insoluble matter <6.06> Perform the test according to Method 1: it meets the requirement.

Insoluble particulate matter <6.07> It meets the requirement.

Sterility <4.06> Perform the test according to the Membrane filtration method: it meets the requirement.

Assay Pipet a volume of Dimorpholamine Injection, equivalent to about 30 mg of dimorpholamine ($C_{20}H_{38}N_4O_4$), and add water to make exactly 200 mL. Pipet 1 mL of this solution, shake with exactly 4 mL of the internal standard solution for 5 minutes, and use this solution as the sample solution. Separately, weigh accurately about 0.15 g of dimorpholamine for assay, previously dried in a desiccator (in vacuum, phosphorus (V) oxide) for 8 hours, and dissolve in water to make exactly 1000 mL. Pipet 1 mL of this solution, shake with exactly 4 mL of the internal standard solution for 5 minutes, and use this solution as the standard solution. Perform the test with 10 μ L each of the sample solution and standard solution as directed under Liquid Chromatography <2.01> according to the following conditions, and calculate the ratios, Q_T and Q_S , of the peak area of dimorpholamine to that of the internal standard.

$$\begin{aligned} \text{Amount (mg) of dimorpholamine (C}_{20}\text{H}_{38}\text{N}_4\text{O}_4) \\ = M_S \times Q_T / Q_S \times 1/5 \end{aligned}$$

M_S : Amount (mg) of dimorpholamine for assay taken

Internal standard solution—A solution of butyl parahydroxybenzoate in acetonitrile (1 in 25,000).

Operating conditions—

Detector: An ultraviolet absorption photometer (wave-

length: 216 nm).

Column: A stainless steel column 4.6 mm in inside diameter and 15 cm in length, packed with octadecylsilanized silica gel for liquid chromatography (5 μ m in particle diameter).

Column temperature: A constant temperature of about 40°C.

Mobile phase: A mixture of water and acetonitrile (1:1).

Flow rate: Adjust so that the retention time of dimorpholamine is about 4 minutes.

System suitability—

System performance: When the procedure is run with 10 μ L of the standard solution under the above operating conditions, dimorpholamine and the internal standard are eluted in this order with the resolution between these peaks being not less than 2.0.

System repeatability: When the test is repeated 6 times with 10 μ L of the standard solution under the above operating conditions, the relative standard deviation of the ratio of the peak area of dimorpholamine to that of the internal standard is not more than 1.0%.

Containers and storage Containers—Hermetic containers.

Dinoprost

ジノプロスト

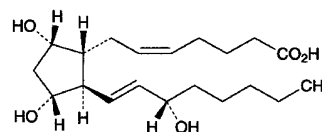

$C_{20}H_{34}O_5$; 354.48

(5Z)-7-[(1R,2R,3R,5S)-3,5-Dihydroxy-2-[(1E,3S)-3-hydroxyoct-1-en-1-yl]cyclopentyl]hept-5-enoic acid [5S1-11-1]

Dinoprost contains not less than 98.5% of dinoprost ($C_{20}H_{34}O_5$), calculated on the anhydrous basis.

Description Dinoprost occurs as white, waxy masses or powder, or a clear, colorless to light yellow and viscous liquid. It is odorless.

It is very soluble in *N,N*-dimethylformamide, freely soluble in methanol, in ethanol (99.5) and in diethyl ether, and very slightly soluble in water.

Identification (1) To 5 mg of Dinoprost add 2 mL of sulfuric acid, and dissolve by shaking for 5 minutes: a dark red color develops. To this solution add 30 mL of sulfuric acid: an orange color develops with a green fluorescence.

(2) Dissolve 1 mg of Dinoprost in 50 mL of diluted sulfuric acid (7 in 10), and warm in a water bath warmed at 50°C for 40 minutes. After cooling, determine the absorption spectrum of the solution as directed under Ultraviolet-visible Spectrophotometry <2.24>, and compare the spectrum with the Reference Spectrum: both spectra exhibit similar intensities of absorption at the same wavelengths.

(3) Warm Dinoprost at 40°C to effect a liquid, and determine the infrared absorption spectrum of the liquid as directed in the liquid film method under Infrared Spectrophotometry <2.25>, and compare the spectrum with the Reference Spectrum: both spectra exhibit similar intensities of absorption at the same wave numbers.

Optical rotation <2.49> $[\alpha]_D^{20}$: +24 – +31° (0.2 g, ethanol (99.5), 10 mL, 100 mm).

Purity (1) Clarity and color of solution—Dissolve 0.20 g of Dinoprost in 5 mL of ethanol (99.5); the solution is clear and colorless to pale yellow.

(2) Related substances—Dissolve 10 mg of Dinoprost in 2 mL of methanol, add water to make 10 mL, and use this solution as the sample solution. Pipet 3 mL of the sample solution, add diluted methanol (1 in 5) to make exactly 100 mL, and use this solution as the standard solution. Perform the test with exactly 10 μ L each of the sample solution and standard solution as directed under Liquid Chromatography <2.01> according to the following conditions. Determine each peak area of these solutions by the automatic integration method: the total area of the peaks other than dinoprost obtained from the sample solution is not larger than the peak area of dinoprost from the standard solution.

Operating conditions—

Detector: An ultraviolet absorption photometer (wavelength: 205 nm).

Column: A stainless steel column about 5 mm in inside diameter and about 15 cm in length, packed with octadecylsilanized silica gel for liquid chromatography (5 μ m in particle diameter).

Column temperature: A constant temperature of about 25°C.

Mobile phase: A mixture of 0.02 mol/L potassium dihydrogenphosphate TS and acetonitrile (5:2).

Flow rate: Adjust so that the retention time of dinoprost is about 20 minutes.

Selection of column: Dissolve 0.01 g each of isopropyl parahydroxybenzoate and propyl parahydroxybenzoate in 2 mL of methanol, and add water to make 10 mL. To 1 mL of this solution add diluted methanol (1 in 5) to make 30 mL, proceed with 10 μ L of this solution under the above operating conditions, and calculate the resolution. Use a column giving elution of isopropyl parahydroxybenzoate and propyl parahydroxybenzoate in this order with the resolution between these peaks being not less than 2.5.

Detection sensitivity: Adjust the detection sensitivity so that the peak height of dinoprost from the standard solution composes 5% to 15% of the full scale.

Time span of measurement: About 1.5 times as long as the retention time of dinoprost, beginning after the solvent peak.

Water <2.48> Not more than 0.5% (0.3 g, volumetric titration, direct titration).

Assay Weigh accurately about 50 mg of Dinoprost, dissolve in 30 mL of *N,N*-dimethylformamide, and titrate <2.50> with 0.02 mol/L tetramethylammonium hydroxide VS under a stream of nitrogen (potentiometric titration). Perform a blank determination in the same manner, and make any necessary correction.

$$\begin{aligned} &\text{Each mL of 0.02 mol/L tetramethylammonium} \\ &\text{hydroxide VS} \\ &= 7.090 \text{ mg of } C_{20}H_{34}O_5 \end{aligned}$$

Containers and storage Containers—Tight containers.

Storage—Light-resistant, and in a place not exceeding 5°C.

Diphenhydramine

ジフェンヒドรามミン

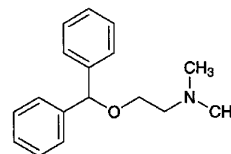

$C_{17}H_{21}NO$: 255.35

2-(Diphenylmethoxy)-*N,N*-dimethylethylamine
[58-73-1]

Diphenhydramine contains not less than 96.0% of diphenhydramine ($C_{17}H_{21}NO$).

Description Diphenhydramine is a clear, light yellow to yellow liquid. It has a characteristic odor, and has a burning taste at first, followed by a slight sensation of numbness on the tongue.

It is miscible with acetic anhydride, with acetic acid (100), with ethanol (95) and with diethyl ether.

It is very slightly soluble in water.

It is gradually affected by light.

Refractive index n_D^{20} : about 1.55

Boiling point: about 162°C (in vacuum, 0.67 kPa).

Identification (1) To 50 mg of Diphenhydramine add 2 mL of sulfuric acid: an orange-red precipitate is produced immediately, and its color changes to red-brown on standing. Add carefully 2 mL of water to this solution: the intensity of the color changes, but the color tone does not change.

(2) Dissolve 0.1 g of Diphenhydramine in 10 mL of dilute ethanol, add an excess of a saturated solution of 2,4,6-trinitrophenol in dilute ethanol with stirring, and cool in ice. Collect the produced crystals, recrystallize from dilute ethanol, and dry at 105°C for 30 minutes: the crystals melt <2.60> between 128°C and 133°C.

Specific gravity <2.56> d_{20}^{20} : 1.013 – 1.020

Purity (1) β -Dimethylaminoethanol—Dissolve 1.0 g of Diphenhydramine in 20 mL of diethyl ether, and extract with two 10-mL portions of water with thorough shaking. Combine the water extracts, and add 2 drops of phenolphthalein TS and 1.0 mL of 0.05 mol/L sulfuric acid VS: no red color develops.

(2) Benzohydrol—Transfer 1.0 g of Diphenhydramine to a separator, dissolve in 20 mL of diethyl ether, and extract with two 25-mL portions of diluted hydrochloric acid (1 in 15) with thorough shaking. Separate the diethyl ether layer, evaporate slowly on a water bath, and dry in a desiccator (in vacuum, silica gel) for 2 hours: the mass of the residue is not more than 20 mg.

(3) Heavy metals <1.07>—Proceed with 1.0 g of Diphenhydramine according to Method 2, and perform the test. Prepare the control solution with 2.0 mL of Standard Lead Solution (not more than 20 ppm).

Residue on ignition <2.44> Not more than 0.1% (1 g).

Assay Weigh accurately about 0.5 g of Diphenhydramine, dissolve in 50 mL of a mixture of acetic anhydride and acetic acid (100) (7:3), and titrate <2.50> with 0.1 mol/L perchloric acid VS (potentiometric titration). Perform a blank determination in the same manner, and make any necessary correction.

Each mL of 0.1 mol/L perchloric acid VS
= 25.54 mg of C₁₇H₂₁NO

Containers and storage Containers—Tight containers.

Storage—Light-resistant, and almost well-filled.

Diphenhydramine Hydrochloride

ジフェンヒドรามミン塩酸塩

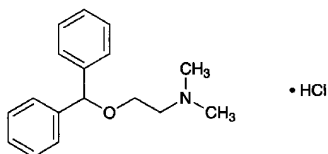

C₁₇H₂₁NO.HCl: 291.82

2-(Diphenylmethoxy)-N,N-dimethylethylamine
monohydrochloride

[147-24-0]

Diphenhydramine Hydrochloride, when dried, contains not less than 98.0% of diphenhydramine hydrochloride (C₁₇H₂₁NO.HCl).

Description Diphenhydramine Hydrochloride occurs as white, crystals or crystalline powder. It is odorless, and has a bitter taste, followed by a sensation of numbness on the tongue.

It is very soluble in methanol and in acetic acid (100), freely soluble in water and in ethanol (95), sparingly soluble in acetic anhydride, and practically insoluble in diethyl ether.

It is gradually affected by light.

Identification (1) Determine the absorption spectrum of a solution of Diphenhydramine Hydrochloride in methanol (1 in 2000) as directed under Ultraviolet-visible Spectrophotometry <2.24>, and compare the spectrum with the Reference Spectrum: both spectra exhibit similar intensities of absorption at the same wavelengths.

(2) Determine the infrared absorption spectrum of Diphenhydramine Hydrochloride as directed in the potassium chloride disk method under Infrared Spectrophotometry <2.25>, and compare the spectrum with the Reference Spectrum: both spectra exhibit similar intensities of absorption at the same wave numbers.

(3) A solution of Diphenhydramine Hydrochloride (1 in 50) responds to Qualitative Tests <1.09> for chloride.

pH <2.54> Dissolve 1.0 g of Diphenhydramine Hydrochloride in 10 mL of water: the pH of this solution is between 4.0 and 5.0.

Melting point <2.60> 166 – 170°C

Purity (1) Clarity and color of solution—Dissolve 1.0 g of Diphenhydramine Hydrochloride in 10 mL of water: the solution is clear and colorless.

(2) Heavy metals <1.07>—Proceed with 1.0 g of Diphenhydramine Hydrochloride according to Method 4, and perform the test. Prepare the control solution with 2.0 mL of Standard Lead Solution (not more than 20 ppm).

(3) Related substances—Dissolve 0.20 g of Diphenhydramine Hydrochloride in 10 mL of methanol, and use this solution as the sample solution. Pipet 1 mL of the sample solution, add methanol to make exactly 200 mL, and use this solution as the standard solution. Perform the test with these solutions as directed under Thin-layer Chromatography <2.03>. Spot 5 μL each of the sample solution and standard

solution on a plate of silica gel for thin-layer chromatography. Develop the plate with a mixture of hexane, ethyl acetate, methanol and ammonia solution (28) (10:4:2:1) to a distance of about 10 cm, and air-dry the plate. Spray evenly iodine TS on the plate: the spots other than the principal spot and the spot on the original point from the sample solution are not more intense than the spot from the standard solution.

Loss on drying <2.41> Not more than 0.5% (2 g, 105°C, 3 hours).

Residue on ignition <2.44> Not more than 0.1% (1 g).

Assay Weigh accurately about 0.4 g of Diphenhydramine Hydrochloride, previously dried, dissolve in 50 mL of a mixture of acetic anhydride and acetic acid (100) (7:3). Titrate <2.50> with 0.1 mol/L perchloric acid VS (potentiometric titration). Perform a blank determination in the same manner, and make any necessary correction.

Each mL of 0.1 mol/L perchloric acid VS
= 29.18 mg of C₁₇H₂₁NO.HCl

Containers and storage Containers—Tight containers.

Storage—Light-resistant.

Diphenhydramine and Bromovalerylurea Powder

ジフェンヒドรามミン・バレリル尿素散

Method of preparation

Diphenhydramine Tannate	90 g
Bromovalerylurea	500 g
Starch, Lactose Hydrate, or their mixture	a sufficient quantity
To make 1000 g	

Prepare as directed under Powders, with the above ingredients.

Description Diphenhydramine and Bromovalerylurea Powder occurs as a slightly grayish white powder.

Identification (1) To 0.1 g of Diphenhydramine and Bromovalerylurea Powder add 5 mL of dilute hydrochloric acid, 1 mL of ethanol (95) and 10 mL of water, shake, and filter. To the filtrate add 10 mL of sodium hydroxide TS, and extract with 10 mL of chloroform. Separate the chloroform layer, add 1 mL of bromophenol blue TS, and shake: a yellow color develops in the chloroform layer (diphenhydramine tannate).

(2) Shake 0.02 g of Diphenhydramine and Bromovalerylurea Powder with 10 mL of diethyl ether, filter, and evaporate the filtrate on a water bath. Dissolve the residue in 2 mL of sodium hydroxide TS, and add 5 mL of dimethylglyoxime-thiosemicarbazide TS, and heat on a water bath for 30 minutes: a red color develops (bromovalerylurea).

(3) Shake 0.3 g of Diphenhydramine and Bromovalerylurea Powder with 5 mL of methanol, filter, and use the filtrate as the sample solution. Dissolve 0.15 of bromovalerylurea and 0.03 g of diphenhydramine tannate in 5 mL each of methanol, and use the solutions as the standard solution (1) and standard solution (2). Perform the test with these solutions as directed under Thin-layer Chromatography <2.03>. Spot 5 μL each of the sample solution and standard solutions (1) and (2) on a plate of silica gel with fluores-

cent indicator for thin-layer chromatography. Develop the plate in a mixture of ethyl acetate, ethanol (99.5) and ammonia solution (28) (50:5:1) to a distance of about 10 cm. Air-dry the plate, and examine under ultraviolet light (main wavelength: 254 nm): 3 spots obtained from the sample solution and the corresponding spot from standard solutions (1) and (2) show the same *R_f* value. Spray Dragendorff's TS for spraying evenly on the plate: the spot from the standard solution (2) and the corresponding spot from the sample solution reveal an orange color.

Containers and storage Containers—Well-closed containers.

Diphenhydramine, Phenol and Zinc Oxide Liniment

ジフェンヒドラミン・フェノール・亜鉛華リニメント

Method of preparation

Diphenhydramine	20 g
Phenol and Zinc Oxide Liniment	980 g
To make 1000 g	

Dissolve and mix the above ingredients.

Description Diphenhydramine, Phenol and Zinc Oxide Liniment is a white to whitish, pasty mass. It has a slight odor of phenol.

Identification (1) To 3 g of Diphenhydramine, Phenol and Zinc Oxide Liniment add 20 mL of hexane, shake well, and separate the hexane layer. Shake thoroughly the hexane solution with 10 mL of 0.2 mol/L hydrochloric acid. Separate the aqueous layer, and adjust with sodium hydroxide TS to a pH of 4.6. Add 1 mL of bromophenol blue-potassium biphthalate TS and 10 mL of chloroform, and shake: a yellow color develops in the chloroform layer (diphenhydramine).

(2) Place 1 g of Diphenhydramine, Phenol and Zinc Oxide Liniment in a porcelain crucible, gradually raise the temperature by heating until the mass is charred, and ignite strongly: a yellow color is produced, and disappears on cooling. To the residue add 10 mL of water and 5 mL of dilute hydrochloric acid, shake well, and filter. Add 2 to 3 drops of potassium hexacyanoferrate (II) TS to the filtrate: a white precipitate is produced (zinc oxide).

(3) Shake 0.5 g of Diphenhydramine, Phenol and Zinc Oxide Liniment with 1 mL of water and 5 mL of chloroform, filter, and use the filtrate as the sample solution. Dissolve 0.01 g each of diphenhydramine and phenol in 5 mL each of chloroform, and use these solutions as the standard solution (1) and standard solution (2). Perform the test with these solutions as directed under Thin-layer Chromatography <2.03>. Spot 5 μ L each of the sample solution and standard solutions (1) and (2) on a plate of silica gel for thin-layer chromatography. Develop the plate with a mixture of ethyl acetate, ethanol (99.5) and ammonia solution (28) (50:5:1) to a distance of about 10 cm, and air-dry the plate. Allow the plate to stand in iodine vapor: two spots obtained from the sample solution and each spot from the standard solution (1) and (2) show the same *R_f* value. Sublime iodine, and spray Dragendorff's TS evenly upon the plate: the spot from standard solution (1) and the corresponding spot from the sample solution reveal an orange color.

Containers and storage Containers—Tight containers.
Storage—Light-resistant.

Diphenhydramine Tannate

タンニン酸ジフェンヒドラミン

Diphenhydramine Tannate is a compound of diphenhydramine and tannic acid.

It contains not less than 25.0% and not more than 35.0% of diphenhydramine ($C_{17}H_{21}NO$: 255.35).

Description Diphenhydramine Tannate occurs as a grayish white to light brown powder. It is odorless or has a slight, characteristic odor. It is tasteless.

It is slightly soluble in ethanol (95), and practically insoluble in water and in diethyl ether.

Identification (1) To 1 g of Diphenhydramine Tannate add 15 mL of water and 0.3 mL of dilute hydrochloric acid, shake thoroughly for 1 minute, filter, and use this filtrate as the sample solution. Transfer 10 mL of the sample solution to a separator, extract with two 20-mL portions of chloroform, combine the chloroform extracts, and evaporate on a water bath to dryness. To 5 mL of a solution of the residue (1 in 100) add 5 drops of Reinecke salt TS: a light red precipitate is produced.

(2) To 10 mL of a solution of the residue obtained in (1) (1 in 100) add 10 mL of 2,4,6-trinitrophenol TS dropwise, and allow to stand for 30 minutes. Collect the precipitate by filtration, recrystallize from dilute ethanol, and dry at 105°C for 30 minutes: the crystals melt <2.60> between 128°C and 133°C.

(3) To 1 mL of the sample solution obtained in (1) add 1 drop of iron (III) chloride TS: a dark blue-purple color develops.

Purity Heavy metals <1.07>—Proceed with 1.0 g of Diphenhydramine Tannate according to Method 2, and perform the test. Prepare the control solution with 2.0 mL of Standard Lead Solution (not more than 20 ppm).

Loss on drying <2.41> Not more than 7.0% (1 g, 105°C, 5 hours).

Residue on ignition <2.44> Not more than 1.0% (1 g).

Assay Transfer about 1.7 g of Diphenhydramine Tannate, accurately weighed, to a separator, dissolve in 20 mL of water and 3.0 mL of dilute hydrochloric acid with thorough shaking, add 20 mL of a solution of sodium hydroxide (1 in 10) and exactly 25 mL of isooctane, shake vigorously for 5 minutes, dissolve 2 g of sodium chloride with shaking, and allow to stand. To 20 mL of the isooctane layer add exactly 80 mL of acetic acid (100), and titrate <2.50> with 0.1 mol/L perchloric acid VS (potentiometric titration). Perform a blank determination in the same manner, and make any necessary correction.

$$\begin{aligned} \text{Each mL of 0.1 mol/L perchloric acid VS} \\ = 25.54 \text{ mg of } C_{17}H_{21}NO \end{aligned}$$

Containers and storage Containers—Tight containers.
Storage—Light-resistant.

Freeze-dried Diphtheria Antitoxin, Equine

乾燥ジフテリアウマ抗毒素

Freeze-dried Diphtheria Antitoxin, Equine, is a preparation for injection which is dissolved before use.

It contains diphtheria antitoxin in immunoglobulin of horse origin.

It conforms to the requirements of Freeze-dried Diphtheria Antitoxin, Equine, in the Minimum Requirements for Biological Products.

Description Freeze-dried Diphtheria Antitoxin, Equine, becomes a colorless or light yellow-brown, clear liquid or a slightly whitish turbid liquid on addition of solvent.

Diphtheria Toxoid

ジフテリアトキソイド

Diphtheria Toxoid is a liquid for injection containing diphtheria toxoid prepared by treating diphtheria toxin with formaldehyde by a method involving no appreciable loss of the immunogenicity.

It conforms to the requirements of Diphtheria Toxoid in the Minimum Requirements for Biological Products.

Description Diphtheria Toxoid is a clear, colorless to light yellow-brown liquid.

Adsorbed Diphtheria Toxoid for Adult Use

成人用沈降ジフテリアトキソイド

Adsorbed Diphtheria Toxoid for Adult Use is a liquid for injection containing diphtheria toxoid prepared by treating diphtheria toxin with formaldehyde by a method involving no appreciable loss of the immunogenicity and very few antigenic substances other than toxoid, and rendered insoluble with aluminum salt.

It conforms to the requirements of Adsorbed Diphtheria Toxoid for Adult Use in the Minimum Requirements of Biological Products.

Description Adsorbed Diphtheria Toxoid for Adult Use becomes a homogeneous, whitish turbid liquid on shaking.

Adsorbed Diphtheria-Purified Pertussis-Tetanus Combined Vaccine

沈降精製百日せきジフテリア破傷風混合ワクチン

Adsorbed Diphtheria-Purified Pertussis-Tetanus Combined Vaccine is a liquid for injection consisting of a liquid containing the protective antigen of *Bordetella pertussis*, Diphtheria Toxoid and a liquid containing tetanus toxoid obtained by detoxifying the tetanus toxin with formaldehyde solution without impairing its immunogenicity, to which aluminum is added to make the antigen and the toxoids insoluble.

It conforms to the requirements of Adsorbed Diphtheria-Purified Pertussis-Tetanus Combined Vaccine in the Minimum Requirements for Biological Products.

Description Adsorbed Diphtheria-Purified Pertussis-Tetanus Combined Vaccine becomes a homogeneous, white turbid liquid on shaking.

Adsorbed Diphtheria-Tetanus Combined Toxoid

沈降ジフテリア破傷風混合トキソイド

Adsorbed Diphtheria-Tetanus Combined Toxoid is a liquid for injection containing diphtheria toxoid and tetanus toxoid which are prepared by treating diphtheria toxin and tetanus toxin, respectively, with formaldehyde by a method involving no appreciable loss of the immunogenicity and rendered insoluble by adding aluminum salt.

It conforms to the requirements of Adsorbed Diphtheria-Tetanus Combined Toxoid in the Minimum Requirements for Biological Products.

Description Adsorbed Diphtheria-Tetanus Combined Toxoid becomes a homogeneous, whitish turbid liquid on shaking.

Dipyridamole

ジピリダモール

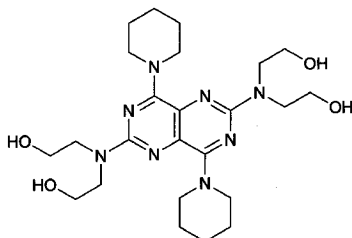

$C_{24}H_{40}N_8O_4$: 504.63
2,2',2'',2'''-[4,8-Di(piperidin-1-yl)pyrimido[5,4-d]pyrimidine-2,6-diyl]dinitrilo}tetraethanol
[58-32-2]

Dipyridamole, when dried, contains not less than 98.5% of dipyridamole ($C_{24}H_{40}N_8O_4$).

Description Dipyridamole occurs as yellow, crystals or crystalline powder. It is odorless, and has a slightly bitter taste.

It is freely soluble in chloroform, sparingly soluble in methanol and in ethanol (99.5), and practically insoluble in water and in diethyl ether.

Identification (1) Dissolve 5 mg of Dipyridamole in 2 mL of sulfuric acid, add 2 drops of nitric acid, and shake: a deep purple color develops.

(2) Determine the absorption spectrum of a solution of Dipyridamole in a mixture of methanol and hydrochloric acid (99:1) (1 in 100,000) as directed under Ultraviolet-visible Spectrophotometry <2.24>, and compare the spectrum with the Reference Spectrum: both spectra exhibit similar intensities of absorption at the same wavelengths.

(3) Determine the infrared absorption spectrum of Dipyridamole, previously dried, as directed in the potassium bromide disk method under Infrared Spectrophotometry <2.25>, and compare the spectrum with the Reference Spectrum: both spectra exhibit similar intensities of absorption at the same wave numbers.

Melting point <2.60> 165 – 169°C

Purity (1) Clarity and color of solution—Dissolve 0.5 g of Dipyridamole in 10 mL of chloroform: the solution is clear, and shows a yellow color.

(2) Heavy metals <1.07>—Proceed with 2.0 g of Dipyridamole according to Method 2, and perform the test. Prepare the control solution with 2.0 mL of Standard Lead Solution (not more than 10 ppm).

(3) Arsenic <1.11>—Prepare the test solution with 1.0 g of Dipyridamole according to Method 3, and perform the test (not more than 2 ppm).

(4) Related substances—Dissolve 50 mg of Dipyridamole in 50 mL of the mobile phase, and use this solution as the sample solution. Pipet 0.5 mL of the sample solution, add the mobile phase to make exactly 100 mL, and use this solution as the standard solution. Perform the test with exactly 20 μ L each of the sample solution and standard solution as directed under Liquid Chromatography <2.01> according to the following conditions, and determine each peak area by the automatic integration method: the total area of the peaks other than dipyridamole obtained from the sample solution is not larger than the peak area of dipyridamole from the

standard solution.

Operating conditions—

Detector: An ultraviolet absorption photometer (wavelength: 280 nm).

Column: A stainless steel column 4 mm in inside diameter and 15 cm in length, packed with octylsilanized silica gel for liquid chromatography (5 μ m in particle diameter).

Column temperature: A constant temperature of about 40°C.

Mobile phase: Dissolve 0.2 g of potassium dihydrogen phosphate in 200 mL of water, and add 800 mL of methanol.

Flow rate: Adjust so that the retention time of dipyridamole is about 4 minutes.

Time span of measurement: About 5 times as long as the retention time of dipyridamole.

System suitability—

Test for required detectability: To exactly 5 mL of the standard solution add the mobile phase to make exactly 25 mL. Confirm that the peak area of dipyridamole obtained with 20 μ L of this solution is equivalent to 15 to 25% of that with 20 μ L of the standard solution.

System performance: Dissolve 7 mg of Dipyridamole and 3 mg of terphenyl in 50 mL of methanol. When the procedure is run with 20 μ L of this solution under the above operating conditions, dipyridamole and terphenyl are eluted in this order with the resolution between these peaks being not less than 5.

System repeatability: When the test is repeated 6 times with 20 μ L of the standard solution under the above operating conditions, the relative standard deviation of the peak area of dipyridamole is not more than 1.0%.

Loss on drying <2.41> Not more than 0.2% (1 g, 105°C, 3 hours).

Residue on ignition <2.44> Not more than 0.1% (1 g).

Assay Weigh accurately about 0.6 g of Dipyridamole, previously dried, dissolve in 70 mL of methanol, and titrate <2.50> with 0.1 mol/L perchloric acid VS (potentiometric titration). Perform a blank determination in the same manner, and make any necessary correction.

Each mL of 0.1 mol/L perchloric acid VS
= 50.46 mg of $C_{24}H_{40}N_8O_4$

Containers and storage Containers—Well-closed containers.

Storage—Light-resistant.

Disopyramide

ジソピラミド

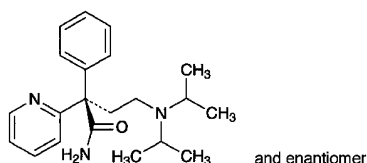

$C_{21}H_{29}N_3O$: 339.47

(2*RS*)-4-Bis(1-methylethyl)amino-2-phenyl-2-(pyridin-2-yl)butanamide

[3737-09-5]

Disopyramide contains not less than 98.5% of disopyramide ($C_{21}H_{29}N_3O$), calculated on the dried basis.

Description Disopyramide occurs as white, crystals or crystalline powder.

It is very soluble in methanol and in ethanol (95), freely soluble in acetic anhydride, in acetic acid (100) and in diethyl ether, and slightly soluble in water.

Identification (1) To 1 mL of a solution of Disopyramide in ethanol (95) (1 in 20) add 10 mL of 2,4,6-trinitrophenol TS, and warm: a yellow precipitate is formed. Filter this precipitate, wash with water, and dry at 105°C for 1 hour: the residue melts <2.60> between 172°C and 176°C.

(2) Determine the absorption spectrum of a solution of Disopyramide in 0.05 mol/L sulfuric acid-methanol TS (1 in 25,000) as directed under Ultraviolet-visible Spectrophotometry <2.24>, and compare the spectrum with the Reference Spectrum: both spectra exhibit similar intensities of absorption at the same wavelengths.

(3) Determine the infrared absorption spectrum of Disopyramide, previously dried, as directed in the potassium bromide disk method under Infrared Spectrophotometry <2.25>, and compare the spectrum with the Reference Spectrum: both spectra exhibit similar intensities of absorption at the same wave numbers.

Absorbance <2.24> $E_{1\text{cm}}^{1\%}$ (269 nm): 194 – 205 (10 mg, 0.05 mol/L sulfuric acid-methanol TS, 500 mL).

Purity (1) Heavy metals <1.07>—Dissolve 1.0 g of Disopyramide in 10 mL of ethanol (95), and add 2 mL of dilute acetic acid and water to make 50 mL. Perform the test using this solution as the test solution. Prepare the control solution as follows: to 2.0 mL of Standard Lead Solution add 10 mL of ethanol (95), 2 mL of dilute acetic acid and water to make 50 mL (not more than 20 ppm).

(2) Arsenic <1.11>—Prepare the test solution with 1.0 g of Disopyramide according to Method 3, and perform the test (not more than 2 ppm).

(3) Related substances—Dissolve 0.40 g of Disopyramide in 10 mL of methanol, and use this solution as the sample solution. Pipet 1 mL of the sample solution, add methanol to make exactly 400 mL, and use this solution as the standard solution. Perform the test with these solutions as directed under Thin-layer Chromatography <2.03>. Spot 10 μL each of the sample solution and standard solution on a plate of silica gel with fluorescent indicator for thin-layer chromatography. Develop the plate with a mixture of 1-butanol, water and ammonia solution (28) (45:4:1) to a distance of about 10 cm, and air-dry the plate. Examine under ultraviolet light (main wavelength: 254 nm): the spots other than the princi-

pal spot obtained from the sample solution are not more intense than the spot from the standard solution.

Loss on drying <2.41> Not more than 0.5% (0.5 g, in vacuum, 80°C, 2 hours).

Residue on ignition <2.44> Not more than 0.2% (1 g).

Assay Weigh accurately about 0.25 g of Disopyramide, dissolve in 30 mL of acetic acid (100), and titrate <2.50> with 0.1 mol/L perchloric acid VS (potentiometric titration). Perform a blank determination in the same manner, and make any necessary correction.

Each mL of 0.1 mol/L perchloric acid VS
= 16.97 mg of $C_{21}H_{29}N_3O$

Containers and storage Containers—Tight containers.

Distigmine Bromide

ジスチグミン臭化物

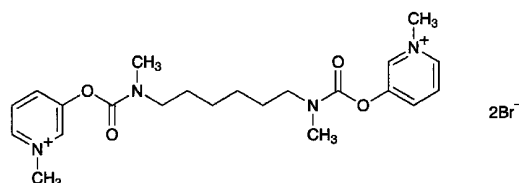

$C_{22}H_{32}Br_2N_4O_4$: 576.32

3,3'-[Hexane-1,6-diylbis(methyliminocarbonyloxy)]bis(1-methylpyridinium) dibromide

[15876-67-2]

Distigmine Bromide contains not less than 98.5% of distigmine bromide ($C_{22}H_{32}Br_2N_4O_4$), calculated on the anhydrous basis.

Description Distigmine Bromide occurs as a white crystalline powder.

It is very soluble in water, freely soluble in methanol, in ethanol (95) and in acetic acid (100), and slightly soluble in acetic anhydride.

The pH of a solution of Distigmine Bromide (1 in 100) is between 5.0 and 5.5.

It is slightly hygroscopic.

It is gradually colored by light.

Melting point: about 150°C (with decomposition).

Identification (1) Determine the absorption spectrum of a solution of Distigmine Bromide (1 in 25,000) as directed under Ultraviolet-visible Spectrophotometry <2.24>, and compare the spectrum with the Reference Spectrum: both spectra exhibit similar intensities of absorption at the same wavelengths.

(2) Determine the infrared absorption spectrum of Distigmine Bromide as directed in the potassium bromide disk method under Infrared Spectrophotometry <2.25>, and compare the spectrum with the Reference Spectrum: both spectra exhibit similar intensities of absorption at the same wave numbers.

(3) To 5 mL of a solution of Distigmine Bromide (1 in 10) add 2 mL of dilute nitric acid: the solution responds to Qualitative Tests <1.09> (1) for bromide.

Purity (1) Clarity and color of solution—Dissolve 0.25 g of Distigmine Bromide in 5 mL of water: the solution is clear and colorless.

(2) Sulfate <1.14>—Perform the test with 0.40 g of Dis-

tigmine Bromide. Prepare the control solution with 0.40 mL of 0.005 mol/L sulfuric acid VS (not more than 0.048%).

(3) Heavy metals <1.07>—Proceed with 2.0 g of Distigmine Bromide according to Method 2, and perform the test. Prepare the control solution with 2.0 mL of Standard Lead Solution (not more than 10 ppm).

(4) Related substances—Dissolve 40 mg of Distigmine Bromide in 10 mL of methanol, and use this solution as the sample solution. Pipet 1 mL of the sample solution, add methanol to make exactly 200 mL, and use this solution as the standard solution. Perform the test with these solutions as directed under Thin-layer Chromatography <2.03>. Spot 10 μ L each of the sample solution and standard solution on a plate of cellulose with fluorescent indicator for thin-layer chromatography. Develop the plate with a mixture of 1-butanol, water, ethanol (99.5) and acetic acid (100) (8:3:2:1) to a distance of about 13 cm, and air-dry the plate. Examine under ultraviolet light (main wavelength: 254 nm); the spots other than the principal spot from the sample solution are not more intense than the spot from the standard solution. Spray evenly Dragendorff's TS for spraying on the plate: the spots other than the principal spot obtained from the sample solution are not more intense than the spot from the standard solution.

Water <2.48> Not more than 1.0% (1 g, volumetric titration, direct titration).

Residue on ignition <2.44> Not more than 0.1% (1 g).

Assay Weigh accurately about 0.4 g of Distigmine Bromide, dissolve in 60 mL of a mixture of acetic anhydride and acetic acid (100) (8:1), and titrate <2.50> with 0.1 mol/L perchloric acid VS (potentiometric titration with platinum electrode). Perform a blank determination in the same manner, and make any necessary correction.

Each mL of 0.1 mol/L perchloric acid VS
= 28.82 mg of $C_{22}H_{32}Br_2N_4O_4$

Containers and storage Containers—Tight containers.
Storage—Light-resistant.

Distigmine Bromide Tablets

ジスチグミン臭化物錠

Distigmine Bromide Tablets contain not less than 95.0% and not more than 105.0% of the labeled amount of distigmine bromide ($C_{22}H_{32}Br_2N_4O_4$; 576.32).

Method of preparation Prepare as directed under Tablets, with Distigmine Bromide.

Identification Determine the absorption spectrum of the sample solution obtained in the Assay, as directed under Ultraviolet-visible Spectrophotometry <2.24>: it exhibits a maximum between 268 nm and 272 nm, and a minimum between 239 nm and 243 nm.

Uniformity of dosage units <6.02> Perform the test according to the following method: it meets the requirement of the Content uniformity test.

To 1 tablet of Distigmine Bromide Tablets add 30 mL of 0.1 mol/L hydrochloric acid TS, shake for 1 hour, add 0.1 mol/L hydrochloric acid TS to make exactly 50 mL, and filter. Discard the first 20 mL of the filtrate, pipet V mL of the subsequent filtrate, and add 0.1 mol/L hydrochloric acid

TS to make exactly V' mL so that each mL contains about 30 μ g of distigmine bromide ($C_{22}H_{32}Br_2N_4O_4$), and use this solution as the sample solution. Proceed as directed in the Assay.

Amount (mg) of distigmine bromide ($C_{22}H_{32}Br_2N_4O_4$)
= $M_S \times (A_{T2} - A_{T1}) / (A_{S2} - A_{S1}) \times V' / V \times 1/20$

M_S : Amount (mg) of distigmine bromide for assay taken, calculated on the anhydrous basis

Dissolution <6.10> When the test is performed at 75 revolutions per minute according to the Paddle method, using 500 mL of water as the dissolution medium, the dissolution rate in 30 minutes of Distigmine Bromide Tablets is not less than 80%.

Start the test with 1 tablet of Distigmine Bromide Tablets, withdraw not less than 20 mL of the medium at the specified minute after starting the test, and filter through a membrane filter with a pore size not exceeding 0.8 μ m. Discard not less than 10 mL of the first filtrate, pipet V mL of the subsequent filtrate, add water to make exactly V' mL so that each mL contains about 10 μ g of distigmine bromide ($C_{22}H_{32}Br_2N_4O_4$), and use this solution as the sample solution. Separately, weigh accurately about 50 mg of distigmine bromide for assay (separately determine the water <2.48> in the same manner as Distigmine Bromide), and dissolve in water to make exactly 100 mL. Pipet 10 mL of this solution, add water to make exactly 500 mL, and use this solution as the standard solution. Perform the test with the sample solution and standard solution as directed under Ultraviolet-visible Spectrophotometry <2.24>, and determine the absorbances, A_{T1} and A_{S1} , at 270 nm, and A_{T2} and A_{S2} , at 350 nm.

Dissolution rate (%) with respect to the labeled amount of distigmine bromide ($C_{22}H_{32}Br_2N_4O_4$)
= $M_S \times (A_{T1} - A_{T2}) / (A_{S1} - A_{S2}) \times V' / V \times 1/C \times 10$

M_S : Amount (mg) of distigmine bromide for assay taken, calculated on the anhydrous basis

C : Labeled amount (mg) of distigmine bromide ($C_{22}H_{32}Br_2N_4O_4$) in 1 tablet

Assay Weigh accurately and powder not less than 20 tablets of Distigmine Bromide Tablets. Weigh accurately a portion of the powder, equivalent to about 15 mg of Distigmine Bromide ($C_{22}H_{32}Br_2N_4O_4$), add 30 mL of 0.1 mol/L hydrochloric acid TS, shake for 1 hour, add 0.1 mol/L hydrochloric acid TS to make exactly 50 mL, and filter. Discard the first 20 mL of the filtrate, pipet 10 mL of the subsequent filtrate, add 0.1 mol/L hydrochloric acid TS to make exactly 100 mL, and use this solution as the sample solution. Separately, weigh accurately about 30 mg of distigmine bromide for assay (previously determine the water <2.48> in the same manner as Distigmine Bromide), and dissolve in 0.1 mol/L hydrochloric acid TS to make exactly 100 mL. Pipet 10 mL of this solution, add 0.1 mol/L hydrochloric acid TS to make exactly 100 mL, and use this solution as the standard solution. Determine the absorbances of the sample solution and standard solution, A_{T2} and A_{S2} , at 270 nm and, A_{T1} and A_{S1} , at 241 nm as directed under Ultraviolet-visible Spectrophotometry <2.24>, respectively.

Amount (mg) of distigmine bromide ($C_{22}H_{32}Br_2N_4O_4$)
= $M_S \times (A_{T2} - A_{T1}) / (A_{S2} - A_{S1}) \times 1/2$

M_S : Amount (mg) of distigmine bromide for assay taken, calculated on the anhydrous basis

Containers and storage Containers—Tight containers.

Disulfiram

ジスルフィラム

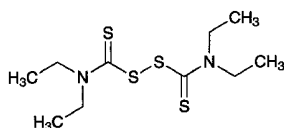

$C_{10}H_{20}N_2S_4$: 296.54
Tetraethylthiuram disulfide
[97-77-8]

Disulfiram, when dried, contains not less than 99.0% of disulfiram ($C_{10}H_{20}N_2S_4$).

Description Disulfiram occurs as white to yellowish white, crystals or crystalline powder.

It is freely soluble in acetone and in toluene, sparingly soluble in methanol and in ethanol (95), and practically insoluble in water.

Identification (1) Determine the absorption spectrum of a solution of Disulfiram in ethanol (95) (1 in 100,000) as directed under Ultraviolet-visible Spectrophotometry <2.24>, and compare the spectrum with the Reference Spectrum: both spectra exhibit similar intensities of absorption at the same wavelengths.

(2) Determine the infrared absorption spectrum of Disulfiram, previously dried, as directed in the potassium bromide disk method under Infrared Spectrophotometry <2.25>, and compare the spectrum with the Reference Spectrum: both spectra exhibit similar intensities of absorption at the same wave numbers.

Melting point <2.60> 70 – 73°C

Purity (1) Heavy metals <1.07>—Proceed with 2.0 g of Disulfiram according to Method 2, and perform the test. Prepare the control solution with 2.0 mL of Standard Lead Solution (not more than 10 ppm).

(2) Arsenic <1.11>—Prepare the test solution with 1.0 g of Disulfiram according to Method 4, and perform the test (not more than 2 ppm).

(3) Diethyldithiocarbamic acid—Dissolve 0.10 g of Disulfiram in 10 mL of toluene, and shake with 10 mL of diluted sodium carbonate TS (1 in 20). Discard the toluene layer, wash the water layer with 10 mL of toluene, shake with 5 drops of a solution of cupric sulfate (1 in 250) and 2 mL of toluene, and allow to stand: no light yellow color develops in the toluene layer.

(4) Related substances—Dissolve 50 mg of Disulfiram in 40 mL of methanol, add water to make 50 mL, and use this solution as the sample solution. Pipet 1 mL of the sample solution, add the mobile phase to make exactly 200 mL, and use this solution as the standard solution. Perform the test with exactly 10 μ L each of the sample solution and the standard solution as directed under Liquid Chromatography <2.01> according to the following conditions. Determine each peak area of both solutions by the automatic integration method: the total area of the peaks other than disulfiram obtained from the sample solution is not larger than the peak area of disulfiram from the standard solution.

Operating conditions—

Detector: An ultraviolet absorption photometer (wavelength: 210 nm).

Column: A stainless steel column about 5 mm in inside diameter and about 15 cm in length, packed with octadecyl-

silanized silica gel for liquid chromatography (5 μ m in particle diameter).

Column temperature: A constant temperature of about 25°C.

Mobile phase: A mixture of methanol and water (7:3).

Flow rate: Adjust so that the retention time of disulfiram is about 8 minutes.

Selection of column: Dissolve 50 mg of Disulfiram and 50 mg of benzophenone in 40 mL of methanol, and add water to make 50 mL. To 1 mL of this solution add the mobile phase to make 200 mL. Proceed with 10 μ L of this solution under the above operating conditions, and calculate the resolution. Use a column giving elution of benzophenone and disulfiram in this order with the resolution between these peaks being not less than 4.

Detection sensitivity: Adjust so that the peak height of disulfiram obtained from 10 μ L of the standard solution is 15 – 30 mm.

Time span of measurement: About 3.5 times of the retention time of disulfiram.

Loss on drying <2.41> Not more than 0.20% (2 g, silica gel, 24 hours).

Residue on ignition <2.44> Not more than 0.1% (2 g).

Assay Weigh accurately about 0.2 g of Disulfiram, previously dried, in an iodine bottle, dissolve in 20 mL of acetone, add 1.5 mL of water and 1.0 g of potassium iodide, and dissolve by shaking thoroughly. To this solution add 3.0 mL of hydrochloric acid, stopper the bottle tightly, shake, and allow to stand in a dark place for 3 minutes. Add 70 mL of water, and titrate <2.50> with 0.1 mol/L sodium thiosulfate VS (potentiometric titration). Perform a blank determination in the same manner, and make any necessary correction.

Each mL of 0.1 mol/L sodium thiosulfate VS
= 14.83 mg of $C_{10}H_{20}N_2S_4$

Containers and storage Containers—Tight containers.

Dobutamine Hydrochloride

ドブタミン塩酸塩

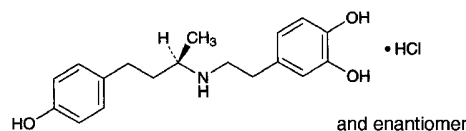

$C_{18}H_{23}NO_3 \cdot HCl$: 337.84
4-[2-[(1*R,S*)-3-(4-Hydroxyphenyl)-1-methylpropylamino]ethyl]benzene-1,2-diol monohydrochloride
[49745-95-1]

Dobutamine Hydrochloride, when dried, contains not less than 98.0% of dobutamine hydrochloride ($C_{18}H_{23}NO_3 \cdot HCl$).

Description Dobutamine Hydrochloride occurs as white to very pale orange, crystalline powder or grains.

It is freely soluble in methanol, sparingly soluble in water and in ethanol (95), and practically insoluble in diethyl ether.

A solution of Dobutamine Hydrochloride (1 in 100) shows no optical rotation.

Identification (1) Determine the infrared absorption spec-

tra of Dobutamine Hydrochloride, previously dried, as directed in the potassium bromide disk method under Infrared Spectrophotometry <2.25>, and compare the spectrum with the Reference Spectrum or the spectrum of dried Dobutamine Hydrochloride RS: both spectra exhibit similar intensities of absorption at the same wave numbers.

(2) A solution of Dobutamine Hydrochloride (1 in 50) responds to Qualitative Tests <1.09> (2) for chloride.

pH <2.54> Dissolve 1.0 g of Dobutamine Hydrochloride in 100 mL of water: the pH of this solution is between 4.0 and 5.5.

Melting point <2.60> 188 – 192°C

Purity (1) Clarity and color of solution—Dissolve 0.5 g of Dobutamine Hydrochloride in 30 mL of water: the solution is clear and colorless.

(2) Heavy metals <1.07>—Dissolve 1.0 g of Dobutamine Hydrochloride in 40 mL of water by warming, cool, and add 2 mL of dilute acetic acid and water to make 50 mL. Perform the test using this solution as the test solution. Prepare the control solution as follows: to 2.0 mL of Standard Lead Solution add water to make 50 mL (not more than 20 ppm).

(3) Related substances—Dissolve 0.10 g of Dobutamine Hydrochloride in 10 mL of methanol, and use this solution as the sample solution. Pipet 1 mL of the sample solution, add methanol to make exactly 200 mL, and use this solution as the standard solution. Perform the test with these solutions as directed under Thin-layer Chromatography <2.03>. Spot 10 μ L each of the sample solution and standard solution on a plate of silica gel for thin-layer chromatography. Develop the plate with a mixture of chloroform, methanol and formic acid (78:22:5) to a distance of about 12 cm, and air-dry the plate. Allow the plate to stand for 5 minutes in iodine vapor: the spots other than the principal spot obtained from the sample solution are not more intense than the spot from the standard solution.

Loss on drying <2.41> Not more than 0.30% (1 g, 105°C, 3 hours).

Residue on ignition <2.44> Not more than 0.1% (1 g).

Assay Weigh accurately about 0.1 g each of Dobutamine Hydrochloride and Dobutamine Hydrochloride RS, each previously dried, dissolve separately in exactly 10 mL of the internal standard solution, add diluted methanol (1 in 2) to make 50 mL, and use these solutions as the sample solution and the standard solution, respectively. Perform the test with 5 μ L each of the sample solution and standard solution as directed under Liquid Chromatography <2.01> according to the following conditions, and calculate the ratios, Q_T and Q_S , of the peak area of dobutamine to that of the internal standard, respectively.

$$\begin{aligned} & \text{Amount (mg) of dobutamine hydrochloride} \\ & (\text{C}_{18}\text{H}_{23}\text{NO}_3 \cdot \text{HCl}) \\ & = M_S \times Q_T / Q_S \end{aligned}$$

M_S : Amount (mg) of Dobutamine Hydrochloride RS taken

Internal standard solution—A solution of salicylamide in diluted methanol (1 in 2) (1 in 125).

Operating conditions—

Detector: An ultraviolet absorption photometer (wavelength: 280 nm).

Column: A stainless steel column 4.0 mm in inside diameter and 15 cm in length, packed with octadecylsilanized silica gel for liquid chromatography (7 μ m in particle diameter).

Column temperature: A constant temperature of about 25°C.

Mobile phase: A mixture of tartrate buffer solution (pH 3.0) and methanol (7:3).

Flow rate: Adjust so that the retention time of dobutamine is about 7 minutes.

System suitability—

System performance: When the procedure is run with 5 μ L of the standard solution under the above operating conditions, dobutamine and internal standard are eluted in this order with the resolution between these peaks being not less than 5.

System repeatability: When the test is repeated 6 times with 5 μ L of the standard solution under the above operating conditions, the relative standard deviation of the ratios of the peak area of dobutamine to that of the internal standard is not more than 1.0%.

Containers and storage Containers—Tight containers.

Docetaxel Hydrate

ドセタキセル水和物

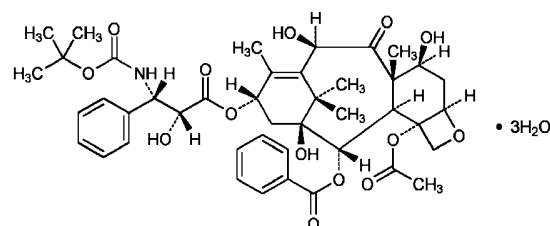

$\text{C}_{43}\text{H}_{53}\text{NO}_{14} \cdot 3\text{H}_2\text{O}$: 861.93

(1*S*,2*S*,3*R*,4*S*,5*R*,7*S*,8*S*,10*R*,13*S*)-4-Acetoxy-2-benzoyloxy-5,20-epoxy-1,7,10-trihydroxy-9-oxotax-11-en-13-yl (2*R*,3*S*)-3-(1,1-dimethylethyl)oxycarbonylamino-2-hydroxy-3-phenylpropanoate trihydrate
[148408-66-6]

Docetaxel Hydrate contains not less than 97.5% and not more than 102.0% of docetaxel ($\text{C}_{43}\text{H}_{53}\text{NO}_{14}$: 807.88), calculated on the anhydrous and residual solvent-free basis.

Description Docetaxel Hydrate occurs as a white crystalline powder.

It is freely soluble in *N,N*-dimethylformamide and in ethanol (99.5), soluble in methanol and in dichloromethane, and practically insoluble in water.

It decomposes on exposure to light.

Identification (1) Determine the absorption spectrum of a solution of Docetaxel Hydrate in methanol (1 in 50,000) as directed under Ultraviolet-visible Spectrophotometry <2.24>, and compare the spectrum with the Reference Spectrum or the spectrum of a solution of Docetaxel Hydrate RS prepared in the same manner as the sample solution: both spectra exhibit similar intensities of absorption at the same wavelengths.

(2) Dissolve 60 mg of Docetaxel Hydrate in 1 mL of dichloromethane. Perform the test with this solution as directed in the solution method under Infrared Spectrophotometry <2.25> using a fixed cell composed of potassium bromide optical plates with the cell length of 0.1 mm, and compare the spectrum with the Reference Spectrum or the spectrum of Docetaxel Hydrate RS: both spectra exhibit similar intensities of absorption at the same wave numbers.

Optical rotation <2.49> $[\alpha]_D^{20}$: $-39 - -41^\circ$ (0.2 g calculated on the anhydrous and residual solvent-free basis, methanol, 20 mL, 100 mm).

Purity (1) Heavy metals <1.07>—Proceed with 1.0 g of Docetaxel Hydrate according to Method 2, and perform the test. Prepare the control solution with 2.0 mL of Standard Lead Solution (not more than 20 ppm).

(2) Related substances—Perform the test with 10 μ L of the sample solution obtained in the Assay, as directed under Liquid Chromatography <2.01> according to the following conditions. Determine each peak area by the automatic integration method, and calculate the amount of them by the area percentage method: the amount of each peak, having the relative retention time of about 0.97, about 1.08, and about 1.13 to docetaxel, is not more than 0.50%, not more than 0.30%, and not more than 0.30%, respectively, the amount of each peak other than docetaxel and the peaks mentioned above is not more than 0.10%, and the total amount of the peaks other than docetaxel is not more than 1.0%. For the area of the peak, having the relative retention time of about 0.97 to docetaxel, multiply the correction factor 1.6.

Operating conditions—

Detector, column, column temperature, mobile phase, and flow rate: Proceed as directed in the operating conditions in the Assay.

Time span of measurement: For 39 minutes after injection, beginning after the solvent peak.

System suitability—

Test for required detectability: To 1 mL of the sample solution add a mixture of water, acetonitrile for liquid chromatography and acetic acid (100) (1000:1000:1) to make 100 mL. To 1 mL of this solution add a mixture of water, acetonitrile for liquid chromatography and acetic acid (100) (1000:1000:1) to make 10 mL, and use this solution as the solution for system suitability test. Pipet 5 mL of the solution for system suitability test, add a mixture of water, acetonitrile for liquid chromatography and acetic acid (100) (1000:1000:1) to make exactly 10 mL. Confirm that the peak area of docetaxel obtained with 10 μ L of this solution is equivalent to 35 to 65% of that with 10 μ L of the solution for system suitability test.

System performance: When the procedure is run with 10 μ L of the solution for system suitability test under the above operating conditions, the number of theoretical plates and the symmetry factor of the peak of docetaxel are not less than 100,000 and not more than 2.0, respectively.

System repeatability: When the test is repeated 6 times with 10 μ L of the solution for system suitability test under the above operating conditions, the relative standard deviation of the peak area of docetaxel is not more than 2.0%.

Water <2.48> 5.0 – 7.0% (50 mg, coulometric titration).

Residue on ignition <2.44> Not more than 0.1% (1 g).

Assay Weigh accurately about 50 mg each of Docetaxel Hydrate and Docetaxel RS (separately determine the water <2.48> and the residual solvent in the same manner as Docetaxel Hydrate), dissolve them separately in 2.5 mL of ethanol (99.5), add a mixture of water, acetonitrile for liquid chromatography and acetic acid (100) (1000:1000:1) to make exactly 50 mL, and use these solutions as the sample solution and the standard solution, respectively. Perform the test with exactly 10 μ L each of the sample solution and standard solution as directed under Liquid Chromatography <2.01> according to the following conditions, and determine the peak areas, A_T and A_S , of docetaxel in each solution.

Amount (mg) of docetaxel ($C_{43}H_{53}NO_{14}$) = $M_S \times A_T/A_S$

M_S : Amount (mg) of Docetaxel RS taken, calculated on the anhydrous and residual solvent-free basis

Operating conditions—

Detector: An ultraviolet absorption photometer (wavelength: 232 nm).

Column: A stainless steel column 4.6 mm in inside diameter and 15 cm in length, packed with octadecylsilanized silica gel for liquid chromatography (3.5 μ m in particle diameter).

Column temperature: A constant temperature of about 45°C.

Mobile phase A: Water.

Mobile phase B: Acetonitrile for liquid chromatography.

Flowing of mobile phase: Control the gradient by mixing the mobile phases A and B as directed in the following table.

Time after injection of sample (min)	Mobile phase A (vol%)	Mobile phase B (vol%)
0 – 9	72	28
9 – 39	72 → 28	28 → 72

Flow rate: 1.2 mL per minute.

System suitability—

System performance: When the procedure is run with 10 μ L of the standard solution under the above operating conditions, the number of theoretical plates and the symmetry factor of the peak of docetaxel are not less than 100,000 and not more than 2.0, respectively.

System repeatability: When the test is repeated 6 times with 10 μ L of the standard solution under the above operating conditions, the relative standard deviation of the peak area of docetaxel is not more than 1.0%.

Containers and storage Containers—Tight containers.

Storage—Light-resistant.

Docetaxel Injection

ドセタキセル注射液

Docetaxel Injection is a hydrophilic injection.

It contains not less than 93.0% and not more than 105.0% of the labeled amount of docetaxel ($C_{43}H_{53}NO_{14}$: 807.88).

Method of preparation Prepare as directed under Injections, with Docetaxel Hydrate.

Description Docetaxel Injection occurs as a clear and pale yellow to orange-yellow, liquid.

Identification To a volume of Docetaxel Injection, equivalent to 20 mg of docetaxel ($C_{43}H_{53}NO_{14}$), add 50 mL of methanol, and use this solution as the sample solution. Separately, dissolve 4 mg of docetaxel hydrate in 10 mL of methanol, and use this solution as the standard solution. Perform the test with these solutions as directed under Thin-layer Chromatography <2.03>. Spot 10 μ L each of the sample solution and standard solution on a plate of silica gel with fluorescent indicator for thin-layer chromatography. Then develop the plate with a mixture of ethyl acetate, heptane and ethanol (99.5) (12:3:1) to a distance of about 10 cm, and air-dry the plate. Examine under ultraviolet light (main wavelength: 254 nm): the R_f value of the spot from the sample solution and the standard solution is the same.

pH Being specified separately when the drug is granted approval based on the Law.

Purity Related substances—Perform the test with 20 μ L of the sample solution obtained in the Assay, as directed under Liquid Chromatography <2.01> according to the following conditions. Determine each peak area by the automatic integration method, and calculate the amount of them by the area percentage method: the amount of each peak, having the relative retention time of about 0.27, about 1.05, about 1.08, about 1.13, and about 1.18 to docetaxel, is not more than 0.30%, not more than 1.3%, not more than 1.5%, not more than 0.50%, and not more than 0.50%, respectively, the amount of each peak other than docetaxel, the peak having the relative retention time of about 0.97 and the peaks mentioned above is not more than 0.20%, and the total amount of the peaks other than docetaxel and the peak having the relative retention time of about 0.97 is not more than 3.5%. For the area of the peak, having the relative retention time of about 0.27 to docetaxel, multiply the correction factor 0.67.

Operating conditions—

Detector, column, column temperature, mobile phase, and flow rate: Proceed as directed in the operating conditions in the Assay under Docetaxel Hydrate.

Time span of measurement: For 39 minutes after injection, beginning after the solvent peak.

System suitability—

Test for required detectability: To 1 mL of the sample solution add a mixture of water, acetonitrile for liquid chromatography and acetic acid (100) (1000:1000:1) to make 100 mL, and use this solution as the solution for system suitability test. Pipet 5 mL of the solution for system suitability test, add a mixture of water, acetonitrile for liquid chromatography and acetic acid (100) (1000:1000:1) to make exactly 100 mL. Confirm that the peak area of docetaxel obtained with 20 μ L of this solution is equivalent to 3.5 to 6.5% of that with 20 μ L of the solution for system suitability test.

System performance: When the procedure is run with 20 μ L of the solution for system suitability test under the above operating conditions, the number of theoretical plates and the symmetry factor of the peak of docetaxel are not less than 100,000 and not more than 2.0, respectively.

System repeatability: When the test is repeated 6 times with 20 μ L of the solution for system suitability test under the above operating conditions, the relative standard deviation of the peak area of docetaxel is not more than 2.0%.

Bacterial endotoxins <4.01> Less than 2.5 EU/mg.

Extractable volume <6.05> It meets the requirement.

Foreign insoluble matter <6.06> Perform the test according to Method 1: it meets the requirement.

Insoluble particulate matter <6.07> It meets the requirement.

Sterility <4.06> Perform the test according to the Membrane filtration method: it meets the requirement.

Assay To exactly a volume of Docetaxel Injection, equivalent to about 20 mg of docetaxel ($C_{43}H_{53}NO_{14}$), add 5 mL of ethanol (99.5), further add a mixture of water, acetonitrile for liquid chromatography and acetic acid (100) (1000:1000:1) to make exactly 100 mL, and use this solution as the sample solution. Separately, weigh accurately about 40 mg of Docetaxel RS (separately determine the water <2.48> and the residual solvent in the same manner as Docetaxel Hydrate), dissolve in 20 mL of ethanol (99.5), add

a mixture of water, acetonitrile for liquid chromatography and acetic acid (100) (1000:1000:1) to make exactly 200 mL, and use this solution as the standard solution. Perform the test with exactly 20 μ L each of the sample solution and standard solution as directed under Liquid Chromatography <2.01> according to the following conditions, and determine the peak areas, A_T and A_S , of docetaxel in each solution.

$$\begin{aligned} \text{Amount (mg) of docetaxel (C}_{43}\text{H}_{53}\text{NO}_{14}) \\ = M_S \times A_T/A_S \times 1/2 \end{aligned}$$

M_S : Amount (mg) of Docetaxel RS taken, calculated on the anhydrous and residual solvent-free basis

Operating conditions—

Proceed as directed in the operating conditions in the Assay under Docetaxel Hydrate.

System suitability—

System performance: When the procedure is run with 20 μ L of the standard solution under the above operating conditions, the number of theoretical plates and the symmetry factor of the peak of docetaxel are not less than 100,000 and not more than 2.0, respectively.

System repeatability: When the test is repeated 6 times with 20 μ L of the standard solution under the above operating conditions, the relative standard deviation of the peak area of docetaxel is not more than 1.0%.

Containers and storage Containers—Hermetic containers.

Storage—Light-resistant.

Docetaxel for Injection

注射用ドセタキセル

Docetaxel for Injection is a preparation for injection which is dissolved before use.

It contains not less than 93.0% and not more than 105.0% of the labeled amount of docetaxel ($C_{43}H_{53}NO_{14}$; 807.88).

Method of preparation Prepare as directed under Injections, with Docetaxel Hydrate.

Description Docetaxel for Injection occurs as a clear and yellow to orange-yellow, viscous liquid.

Identification To an amount of Docetaxel for Injection, equivalent to 20 mg of docetaxel ($C_{43}H_{53}NO_{14}$), add 50 mL of methanol, and use this solution as the sample solution. Separately, dissolve 4 mg of docetaxel hydrate in 10 mL of methanol, and use this solution as the standard solution. Perform the test with these solutions as directed under Thin-layer Chromatography <2.03>. Spot 10 μ L each of the sample solution and standard solution on a plate of silica gel with fluorescent indicator for thin-layer chromatography. Then develop the plate with a mixture of ethyl acetate, heptane and ethanol (99.5) (12:3:1) to a distance of about 10 cm, and air-dry the plate. Examine under ultraviolet light (main wavelength: 254 nm): the R_f value of the spot obtained from the sample solution and the standard solution is the same.

pH Being specified separately when the drug is granted approval based on the Law.

Purity Related substances—Perform the test with 20 μ L of the sample solution obtained in the Assay, as directed under Liquid Chromatography <2.01> according to the following conditions. Determine each peak area by the automatic integration method, and calculate the amount of them by the

area percentage method: the amount of each peak, having the relative retention time of about 0.27, about 1.05, about 1.08, about 1.13, and about 1.18 to docetaxel, is not more than 0.30%, not more than 1.3%, not more than 1.5%, not more than 0.50%, and not more than 0.50%, respectively, the amount of each peak other than docetaxel, the peak having the relative retention time of about 0.97 and the peaks mentioned above is not more than 0.20%, and the total amount of the peaks other than docetaxel and the peak having the relative retention time of about 0.97 is not more than 3.5%. For the area of the peak, having the relative retention time of about 0.27 to docetaxel, multiply the correction factor 0.67.

Operating conditions—

Detector, column, column temperature, mobile phase, and flow rate: Proceed as directed in the operating conditions in the Assay under Docetaxel Hydrate.

Time span of measurement: For 39 minutes after injection, beginning after the solvent peak.

System suitability—

Test for required detectability: To 1 mL of the sample solution add a mixture of water, acetonitrile for liquid chromatography and acetic acid (100) (1000:1000:1) to make 100 mL, and use this solution as the solution for system suitability test. Pipet 5 mL of the solution for system suitability test, add a mixture of water, acetonitrile for liquid chromatography and acetic acid (100) (1000:1000:1) to make exactly 100 mL. Confirm that the peak area of docetaxel obtained with 20 μ L of this solution is equivalent to 3.5 to 6.5% of that with 20 μ L of the solution for system suitability test.

System performance: When the procedure is run with 20 μ L of the solution for system suitability test under the above operating conditions, the number of theoretical plates and the symmetry factor of the peak of docetaxel are not less than 100,000 and not more than 2.0, respectively.

System repeatability: When the test is repeated 6 times with 20 μ L of the solution for system suitability test under the above operating conditions, the relative standard deviation of the peak area of docetaxel is not more than 2.0%.

Bacterial endotoxins <4.01> Less than 2.5 EU/mg.

Uniformity of dosage units <6.02> It meets the requirement of the Mass variation test. (*T*: 120.0%).

Foreign insoluble matter <6.06> Perform the test according to Method 2: it meets the requirement.

Insoluble particulate matter <6.07> It meets the requirement.

Sterility <4.06> Perform the test according to the Membrane filtration method: it meets the requirement.

Assay Weigh accurately an amount of Docetaxel for Injection, equivalent to about 20 mg of docetaxel (C₄₃H₅₃NO₁₄), add 5 mL of ethanol (99.5), further add a mixture of water, acetonitrile for liquid chromatography and acetic acid (100) (1000:1000:1) to make exactly 100 mL, and use this solution as the sample solution. Separately, weigh accurately about 40 mg of Docetaxel RS (separately determine the water <2.48> and the residual solvent in the same manner as Docetaxel Hydrate), dissolve in 20 mL of ethanol (99.5), add a mixture of water, acetonitrile for liquid chromatography and acetic acid (100) (1000:1000:1) to make exactly 200 mL, and use this solution as the standard solution. Perform the test with exactly 20 μ L each of the sample solution and standard solution as directed under Liquid Chromatography <2.01> according to the following conditions, and determine the peak areas, *A_T* and *A_S*, of docetaxel in each solution.

Amount (mg) of docetaxel (C₄₃H₅₃NO₁₄) in 1 mL of Docetaxel for Injection

$$= M_S/M_T \times A_T/A_S \times d \times 1/2$$

M_S: Amount (mg) of Docetaxel RS taken, calculated on the anhydrous and residual solvent-free basis

M_T: Amount (mg) of Docetaxel for Injection taken

d: Density (g/mL) of Docetaxel for Injection

Operating conditions—

Proceed as directed in the operating conditions in the Assay under Docetaxel Hydrate.

System suitability—

System performance: When the procedure is run with 20 μ L of the standard solution under the above operating conditions, the number of theoretical plates and the symmetry factor of the peak of docetaxel are not less than 100,000 and not more than 2.0, respectively.

System repeatability: When the test is repeated 6 times with 20 μ L of the standard solution under the above operating conditions, the relative standard deviation of the peak area of docetaxel is not more than 1.0%.

Containers and storage Containers—Hermetic containers.

Storage—Light-resistant.

Domperidone

ドンペリドン

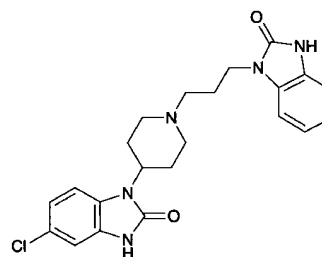

C₂₂H₂₄ClN₅O₂: 425.91

5-Chloro-1-[1-[3-(2-oxo-2,3-dihydro-1*H*-benzimidazol-1-yl)propyl]piperidin-4-yl]-1,3-dihydro-2*H*-benzimidazol-2-one

[57808-66-9]

Domperidone, when dried, contains not less than 99.0% and not more than 101.0% of domperidone (C₂₂H₂₄ClN₅O₂).

Description Domperidone occurs as a white to pale yellow, crystalline powder or powder.

It is freely soluble in acetic acid (100), slightly soluble in methanol and in ethanol (99.5), very slightly soluble in 2-propanol, and practically insoluble in water.

Melting point: about 243°C (with decomposition).

Identification (1) Determine the absorption spectrum of a solution of Domperidone in a mixture of 2-propanol and 0.1 mol/L hydrochloric acid TS (9:1) (1 in 50,000) as directed under Ultraviolet-visible Spectrophotometry <2.24>, and compare the spectrum with the Reference Spectrum: both spectra exhibit similar intensities of absorption at the same wavelengths.

(2) Determine the infrared absorption spectrum of Domperidone as directed in the potassium bromide disk method under Infrared Spectrophotometry <2.25>, and compare the spectrum with the Reference Spectrum: both spectra exhibit similar intensities of absorption at the same wave

numbers.

Purity (1) Heavy metals <1.07>—Proceed with 2.0 g of Domperidone according to Method 2, and perform the test. Prepare the control solution with 2.0 mL of Standard Lead Solution (not more than 10 ppm).

(2) Related substances—Dissolve 30 mg of Domperidone in 100 mL of methanol, and use this solution as the sample solution. Pipet 1 mL of the sample solution, add methanol to make exactly 200 mL, and use this solution as the standard solution. Perform the test with exactly 10 μ L each of the sample solution and standard solution as directed under Liquid Chromatography <2.01> according to the following conditions, and determine each peak area of each solution by the automatic integration method: the area of each peak other than domperidone obtained from the sample solution is not larger than 1/2 times the peak area of domperidone from the standard solution. Furthermore, the total area of the peaks other than domperidone is not larger than the peak area of domperidone from the standard solution.

Operating conditions—

Detector: An ultraviolet absorption photometer (wavelength: 287 nm).

Column: A stainless steel column 4.6 mm in inside diameter and 25 cm in length, packed with octylsilanized silica gel for liquid chromatography (5 μ m in particle diameter).

Column temperature: A constant temperature of about 35°C.

Mobile phase: Dissolve 2.72 g of potassium dihydrogen phosphate in water to make 1000 mL, and adjust the pH to 3.5 of this solution with a solution prepared by dissolving 2.31 g of phosphoric acid in water to make 1000 mL. To 500 mL of this solution add 500 mL of methanol.

Flow rate: Adjust so that the retention time of domperidone is about 9 minutes.

Time span of measurement: About 4 times as long as the retention time of domperidone, beginning after the solvent peak.

System suitability—

Test for required detectability: Pipet 2 mL of the standard solution, and add methanol to make exactly 5 mL. Confirm that the peak area of domperidone obtained with 10 μ L of this solution is equivalent to 30 to 50% of that with 10 μ L of the standard solution.

System performance: Dissolve 10 mg of Domperidone and 20 mg of ethyl parahydroxybenzoate in 100 mL of methanol. When the procedure is run with 10 μ L of this solution under the above operating conditions, domperidone and ethyl parahydroxybenzoate are eluted in this order with the resolution between these peaks being not less than 1.5.

System repeatability: When the test is repeated 6 times with 10 μ L of the standard solution under the above operating conditions, the relative standard deviation of the peak area of domperidone is not more than 3.0%.

Loss on drying <2.41> Not more than 0.5% (1 g, 105°C, 4 hours).

Residue on ignition <2.44> Not more than 0.1% (1 g).

Assay Weigh accurately about 0.5 g of Domperidone, previously dried, dissolve in 50 mL of acetic acid (100), and titrate <2.50> with 0.1 mol/L perchloric acid VS (potentiometric titration). Perform a blank determination in the same manner, and make any necessary correction.

Each mL of 0.1 mol/L perchloric acid VS
= 42.59 mg of C₂₂H₂₄ClN₅O₂

Containers and storage Containers—Well-closed contain-

ers.

Storage—Light-resistant.

Donepezil Hydrochloride

ドネペジル塩酸塩

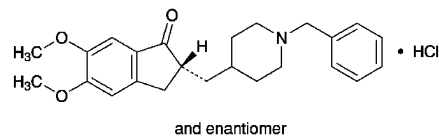

C₂₄H₂₉NO₃·HCl: 415.95

(2*RS*)-2-[(1-Benzylpiperidin-4-yl)methyl]-5,6-dimethoxy-2,3-dihydro-1*H*-inden-1-one monohydrochloride
[120011-70-3]

Donepezil Hydrochloride contains not less than 98.0% and not more than 102.0% of donepezil hydrochloride (C₂₄H₂₉NO₃·HCl), calculated on the anhydrous basis.

Description Donepezil Hydrochloride occurs as a white crystalline powder.

It is soluble in water, and slightly soluble in ethanol (99.5).

A solution of Donepezil Hydrochloride (1 in 100) shows no optical rotation.

Donepezil Hydrochloride shows crystal polymorphism.

Identification (1) Determine the absorption spectrum of a solution of Donepezil Hydrochloride (1 in 50,000) as directed under Ultraviolet-visible Spectrophotometry <2.24>, and compare the spectrum with the Reference Spectrum or the spectrum of a solution of Donepezil Hydrochloride RS prepared in the same manner as the sample solution: both spectra exhibit similar intensities of absorption at the same wavelengths.

(2) Determine the infrared absorption spectrum of Donepezil Hydrochloride as directed in the potassium bromide disk method under Infrared Spectrophotometry <2.25>, and compare the spectrum with the Reference Spectrum or the spectrum of Donepezil Hydrochloride RS: both spectra exhibit similar intensities of absorption at the same wave numbers. If any difference appears between the spectra, recrystallize the sample and the RS according to the method otherwise specified, filter and dry the crystals, and perform the test with the crystals.

(3) A solution of Donepezil Hydrochloride (1 in 50) responds to Qualitative Tests <1.09> (2) for chloride.

Purity (1) Heavy metals <1.07>—To 1.0 g of Donepezil Hydrochloride in a porcelain or platinum crucible add 5 mL of sulfuric acid, incinerate by heating gradually, then incinerate by ignition between 500 and 600°C. If a carbonized residue still retains, moisten the residue with a little amount of sulfuric acid, and incinerate again by ignition between 500 and 600°C. After cooling, dissolve the residue with 3 mL of hydrochloric acid, then evaporate to dryness on a water bath or hot plate, and dissolve the residue with 10 mL of water by warming. Then, proceed as directed in Method 4, and perform the test. Prepare the control solution with 1.0 mL of Standard Lead Solution (not more than 10 ppm).

(2) Related substances—Dissolve 50 mg of Donepezil Hydrochloride in 25 mL of the mobile phase. To 10 mL of this solution add the mobile phase to make 50 mL, and use this solution as the sample solution. Pipet 2 mL of the sample solution, and add the mobile phase to make exactly 100

mL. Pipet 5 mL of this solution, add the mobile phase to make exactly 100 mL, and use this solution as the standard solution. Perform the test with exactly 20 μ L each of the sample solution and standard solution as directed under Liquid Chromatography <2.01> according to the following conditions, and determine each peak area by the automatic integration method: the area of the peak other than donepezil obtained from the sample solution is not larger than the peak area of donepezil from the standard solution.

Operating conditions—

Detector, column, column temperature, mobile phase, and flow rate: Proceed as directed in the operating conditions in the Assay.

Time span of measurement: About 2 times as long as the retention time of donepezil, beginning after the solvent peak.

System suitability—

System performance: When the procedure is run with 20 μ L of the standard solution under the above operating conditions, the number of theoretical plates and the symmetry factor of the peak of donepezil are not less than 5000 and not more than 1.5, respectively.

System repeatability: When the test is repeated 6 times with 20 μ L of the standard solution under the above operating conditions, the relative standard deviation of the peak area of donepezil is not more than 2.0%.

Water <2.48> Not more than 0.2% (0.2 g, coulometric titration).

Residue on ignition <2.44> Not more than 0.1% (1 g).

Assay Weigh accurately about 50 mg each of Donepezil Hydrochloride and Donepezil Hydrochloride RS (separately determine the water <2.48> in the same manner as Donepezil Hydrochloride), dissolve them in the mobile phase to make exactly 25 mL. Pipet 10 mL each of these solutions, add the mobile phase to make exactly 50 mL, and use these solutions as the sample solution and the standard solution, respectively. Perform the test with exactly 20 μ L each of the sample solution and standard solution as directed under Liquid Chromatography <2.01> according to the following conditions, and determine the peak areas, A_T and A_S , of donepezil in each solution.

Amount (mg) of donepezil hydrochloride ($C_{24}H_{29}NO_3 \cdot HCl$)
 $= M_S \times A_T / A_S$

M_S : Amount (mg) of Donepezil Hydrochloride RS taken, calculated on the anhydrous basis

Operating conditions—

Detector: An ultraviolet absorption photometer (wavelength: 271 nm).

Column: A stainless steel column 4.6 mm in inside diameter and 15 cm in length, packed with octadecylsilanized silica gel for liquid chromatography (5 μ m in particle diameter).

Column temperature: A constant temperature of about 35°C.

Mobile phase: Dissolve 2.5 g of sodium 1-decansulfonate in 650 mL of water, and add 350 mL of acetonitrile and 1 mL of perchloric acid.

Flow rate: Adjust so that the retention time of donepezil is about 11 minutes.

System suitability—

System performance: When the procedure is run with 20 μ L of the standard solution under the above operating conditions, the number of theoretical plates and the symmetry factor of the peak of donepezil are not less than 5000 and not more than 1.5, respectively.

System repeatability: When the test is repeated 6 times

with 20 μ L of the standard solution under the above operating conditions, the relative standard deviation of the peak area of donepezil is not more than 1.0%.

Containers and storage Containers—Well-closed containers.

Donepezil Hydrochloride Fine Granules

ドネペジル塩酸塩細粒

Donepezil Hydrochloride Fine Granules contain not less than 95.0% and not more than 105.0% of the labeled amount of donepezil hydrochloride ($C_{24}H_{29}NO_3 \cdot HCl$; 415.95).

Method of preparation Prepare as directed under Granules, with Donepezil Hydrochloride.

Identification To 2.5 mL of the sample solution obtained in the Assay add water to make 100 mL. Determine the absorption spectrum of this solution as directed under Ultraviolet-visible Spectrophotometry <2.24>: it exhibits maxima between 228 nm and 232 nm, between 269 nm and 273 nm, and between 313 nm and 317 nm.

Uniformity of dosage units <6.02> Perform the test according to the following method: the Donepezil Hydrochloride Fine Granules in single-dose packages meet the requirement of the Content uniformity test.

To the total amount of the content of 1 package of Donepezil Hydrochloride Fine Granule add exactly V mL of 0.1 mol/L hydrochloric acid TS so that each mL contains about 0.2 mg of donepezil hydrochloride ($C_{24}H_{29}NO_3 \cdot HCl$), disperse the particles by sonicating with occasional shaking, and sonicate for a further 10 minutes. Centrifuge this solution, and use the supernatant liquid as the sample solution. Separately, weigh accurately about 50 mg of Donepezil Hydrochloride RS, (separately determine the water <2.48> in the same manner as Donepezil Hydrochloride), dissolve in a mixture of methanol and 0.1 mol/L hydrochloric acid TS (3:1) to make exactly 25 mL. Pipet 5 mL of this solution, add 0.1 mol/L hydrochloric acid TS to make exactly 50 mL, and use this solution as the standard solution. Perform the test with exactly 20 μ L each of the sample solution and standard solution as directed under Liquid Chromatography <2.01> according to the following conditions, and determine the peak areas, A_T and A_S , of donepezil in each solution.

Amount (mg) of donepezil hydrochloride ($C_{24}H_{29}NO_3 \cdot HCl$)
 $= M_S \times A_T / A_S \times V / 250$

M_S : Amount (mg) of Donepezil Hydrochloride RS taken, calculated on the anhydrous basis

Operating conditions—

Proceed as directed in the operating conditions in the Assay under Donepezil Hydrochloride.

System suitability—

System performance: When the procedure is run with 20 μ L of the standard solution under the above operating conditions, the number of theoretical plates and the symmetry factor of the peak of donepezil are not less than 4000 and not more than 1.5, respectively.

System repeatability: When the test is repeated 6 times with 20 μ L of the standard solution under the above operating conditions, the relative standard deviation of the peak

area of donepezil is not more than 1.0%.

Dissolution <6.10> When the test is performed at 50 revolutions per minute according to the Paddle method, using 900 mL of 2nd fluid for dissolution test as the dissolution medium, the dissolution rate in 15 minutes of Donepezil Hydrochloride Fine Granules is not less than 80%.

Start the test with an accurately weighed amount of Donepezil Hydrochloride Fine Granules, equivalent to about 3 mg of donepezil hydrochloride ($C_{24}H_{29}NO_3 \cdot HCl$), withdraw not less than 20 mL of the medium at the specified minute after starting the test, and filter through a membrane filter with a pore size not exceeding $0.45 \mu m$. Discard not less than 10 mL of the first filtrate, and use the subsequent filtrate as the sample solution. Separately, weigh accurately about 55 mg of Donepezil Hydrochloride RS (separately determine the water <2.48> in the same manner as Donepezil Hydrochloride), and dissolve in a mixture of methanol and 0.1 mol/L hydrochloric acid (3:1) to make exactly 50 mL. Pipet 5 mL of this solution, add the dissolution medium to make exactly 50 mL. Pipet 3 mL of this solution, add the dissolution medium to make exactly 100 mL, and use this solution as the standard solution. Perform the test with exactly $50 \mu L$ each of the sample solution and standard solution as directed under Liquid Chromatography <2.01> according to the following conditions, and determine the peak areas, A_T and A_S , of donepezil in each solution.

Dissolution rate (%) with respect to the labeled amount of donepezil hydrochloride ($C_{24}H_{29}NO_3 \cdot HCl$)

$$= M_S / M_T \times A_T / A_S \times 1 / C \times 27 / 5$$

M_S : Amount (mg) of Donepezil Hydrochloride RS taken, calculated on the anhydrous basis

M_T : Amount (mg) of Donepezil Hydrochloride Fine Granules taken

C : Labeled amount (mg) of donepezil hydrochloride ($C_{24}H_{29}NO_3 \cdot HCl$) in 1 g

Operating conditions—

Detector, column, and column temperature: Proceed as directed in the operating conditions in the Assay under Donepezil Hydrochloride.

Mobile phase: A mixture of water, acetonitrile and perchloric acid (650:350:1).

Flow rate: Adjust so that the retention time of donepezil is about 4 minutes.

System suitability—

System performance: When the procedure is run with $50 \mu L$ of the standard solution under the above operating conditions, the number of theoretical plates and the symmetry factor of the peak of donepezil are not less than 5000 and not more than 1.5, respectively.

System repeatability: When the test is repeated 6 times with $50 \mu L$ of the standard solution under the above operating conditions, the relative standard deviation of the peak area of donepezil is not more than 1.0%.

Assay Powder Donepezil Hydrochloride Fine Granules, if necessary. Weigh accurately a portion of the powder, equivalent to about 20 mg of donepezil hydrochloride ($C_{24}H_{29}NO_3 \cdot HCl$), add 30 mL of 0.1 mol/L hydrochloric acid TS, disperse into the fine particles by sonicating with occasional shaking, and sonicate for a further 15 minutes. Add 0.1 mol/L hydrochloric acid TS to make exactly 50 mL. Centrifuge this solution, and use the supernatant liquid as the sample solution. Separately, weigh accurately about 50 mg of Donepezil Hydrochloride RS (separately determine the water <2.48> in the same manner as Donepezil Hydro-

chloride), and dissolve in a mixture of methanol and 0.1 mol/L hydrochloric acid TS (3:1) to make exactly 25 mL. Pipet 10 mL of this solution, add 0.1 mol/L hydrochloric acid TS to make exactly 50 mL, and use this solution as the standard solution. Perform the test with exactly $20 \mu L$ each of the sample solution and standard solution as directed under Liquid Chromatography <2.01> according to the following conditions, and determine the peak areas, A_T and A_S , of donepezil in each solution.

Amount (mg) of donepezil hydrochloride ($C_{24}H_{29}NO_3 \cdot HCl$)

$$= M_S \times A_T / A_S \times 2 / 5$$

M_S : Amount (mg) of Donepezil Hydrochloride RS taken, calculated on the anhydrous basis

Operating conditions—

Proceed as directed in the operating conditions in the Assay under Donepezil Hydrochloride.

System suitability—

System performance: When the procedure is run with $20 \mu L$ of the standard solution under the above operating conditions, the number of theoretical plates and the symmetry factor of the peak of donepezil are not less than 5000 and not more than 1.5, respectively.

System repeatability: When the test is repeated 6 times with $20 \mu L$ of the standard solution under the above operating conditions, the relative standard deviation of the peak area of donepezil is not more than 1.0%.

Containers and storage Containers—Well-closed containers.

Storage—Light-resistant.

Donepezil Hydrochloride Tablets

ドネペジル塩酸塩錠

Donepezil Hydrochloride Tablets contain not less than 95.0% and not more than 105.0% of the labeled amount of donepezil hydrochloride ($C_{24}H_{29}NO_3 \cdot HCl$; 415.95).

Method of preparation Prepare as directed under Tablets, with Donepezil Hydrochloride.

Identification To 2.5 mL of the sample solution obtained in the Assay add water to make 100 mL. Determine the absorption spectrum of this solution as directed under Ultraviolet-visible Spectrophotometry <2.24>: it exhibits maxima between 228 nm and 232 nm, between 269 nm and 273 nm, and between 313 nm and 317 nm.

Uniformity of dosage units <6.02> Perform the test according to the following method: it meets the requirement of the Content uniformity test.

To 1 tablet of Donepezil Hydrochloride Tablets add exactly V mL of a mixture of methanol and 0.1 mol/L hydrochloric acid TS (3:1) so that each mL contains about 0.2 mg of donepezil hydrochloride ($C_{24}H_{29}NO_3 \cdot HCl$), disperse by sonicating. Shake until the tablet is disintegrated, and sonicate for a further 10 minutes. Centrifuge this solution, and use the supernatant liquid as the sample solution. Separately, weigh accurately about 50 mg of Donepezil Hydrochloride RS (separately, determine the water <2.48> in the same manner as Donepezil Hydrochloride), dissolve in a mixture of methanol and 0.1 mol/L hydrochloric acid TS (3:1) to make exactly 25 mL. Pipet 5 mL of this solution, add a mixture of methanol and 0.1 mol/L hydrochloric acid TS (3:1) to make

exactly 50 mL, and use this solution as the standard solution. Perform the test with exactly 20 μ L each of the sample solution and standard solution as directed under Liquid Chromatography <2.01> according to the following conditions, and determine the peak areas, A_T and A_S , of donepezil in each solution.

$$\text{Amount (mg) of donepezil hydrochloride (C}_{24}\text{H}_{29}\text{NO}_3\cdot\text{HCl)} \\ = M_S \times A_T/A_S \times V/250$$

M_S : Amount (mg) of Donepezil Hydrochloride RS taken, calculated on the anhydrous basis

Operating conditions—

Proceed as directed in the operating conditions in the Assay under Donepezil Hydrochloride.

System suitability—

System performance: When the procedure is run with 20 μ L of the standard solution under the above operating conditions, the number of theoretical plates and the symmetry factor of the peak of donepezil are not less than 4000 and not more than 1.5, respectively.

System repeatability: When the test is repeated 6 times with 20 μ L of the standard solution under the above operating conditions, the relative standard deviation of the peak area of donepezil is not more than 1.0%.

Dissolution <6.10> When the test is performed at 50 revolutions per minute according to the Paddle method, using 900 mL of 2nd fluid for dissolution test as the dissolution medium, the dissolution rate in 15 minutes of Donepezil Hydrochloride Tablets is not less than 80%.

Start the test with 1 tablet of Donepezil Hydrochloride Tablets, withdraw not less than 20 mL of the medium at the specified minute after starting the test, and filter through a membrane filter with a pore size not exceeding 0.45 μ m. Discard not less than 10 mL of the first filtrate, pipet V mL of the subsequent filtrate, add the dissolution medium to make exactly V' mL so that each mL contains about 3.3 μ g of donepezil hydrochloride (C₂₄H₂₉NO₃·HCl), and use this solution as the sample solution. Separately, weigh accurately about 55 mg of Donepezil Hydrochloride RS (separately determine the water <2.48> in the same manner as Donepezil Hydrochloride), and dissolve in a mixture of methanol and 0.1 mol/L hydrochloric acid TS (3:1) to make exactly 50 mL. Pipet 5 mL of this solution, and add the dissolution medium to make exactly 50 mL. Further, pipet 3 mL of this solution, add the dissolution medium to make exactly 100 mL, and use this solution as the standard solution. Perform the test with exactly 50 μ L each of the sample solution and standard solution as directed under Liquid Chromatography <2.01> according to the following conditions, and determine the peak areas, A_T and A_S , of donepezil in each solution.

$$\text{Dissolution rate (\%)} \text{ with respect to the labeled amount} \\ \text{of donepezil hydrochloride (C}_{24}\text{H}_{29}\text{NO}_3\cdot\text{HCl)} \\ = M_S \times A_T/A_S \times V'/V \times 1/C \times 27/5$$

M_S : Amount (mg) of Donepezil Hydrochloride RS taken, calculated on the anhydrous basis

C : Labeled amount (mg) of donepezil hydrochloride (C₂₄H₂₉NO₃·HCl) in 1 tablet

Operating conditions—

Detector, column, and column temperature: Proceed as directed in the operating conditions in the Assay under Donepezil Hydrochloride.

Mobil phase: A mixture of water, acetonitrile and perchloric acid (650:350:1).

Flow rate: Adjust so that the retention time of donepezil is

about 4 minutes.

System suitability—

System performance: When the procedure is run with 50 μ L of the standard solution under the above operating conditions, the number of theoretical plates and the symmetry factor of the peak of donepezil are not less than 5000 and not more than 1.5, respectively.

System repeatability: When the test is repeated 6 times with 50 μ L of the standard solution under the above operating conditions, the relative standard deviation of the peak area of donepezil is not more than 1.0%.

Assay Accurately weigh the mass of not less than 20 Donepezil Hydrochloride Tablets and powder. Weigh accurately a portion of the powder, equivalent to about 20 mg of donepezil hydrochloride (C₂₄H₂₉NO₃·HCl), add 30 mL of a mixture of methanol and 0.1 mol/L hydrochloric acid TS (3:1), disperse by sonicating, and add a mixture of methanol and 0.1 mol/L hydrochloric acid TS (3:1) to make exactly 50 mL. Centrifuge this solution, and use the supernatant liquid as the sample solution. Separately, weigh accurately about 50 mg of Donepezil Hydrochloride RS (separately, determine the water <2.48> in the same manner as Donepezil Hydrochloride), dissolve in a mixture of methanol and 0.1 mol/L hydrochloric acid TS (3:1) to make exactly 25 mL. Pipet 10 mL of this solution, add a mixture of methanol and 0.1 mol/L hydrochloric acid TS (3:1) to make exactly 50 mL, and use this solution as the standard solution. Perform the test with exactly 20 μ L each of the sample solution and standard solution as directed under Liquid Chromatography <2.01> according to the following conditions, and determine the peak areas, A_T and A_S , of donepezil in each solution.

$$\text{Amount (mg) of donepezil hydrochloride (C}_{24}\text{H}_{29}\text{NO}_3\cdot\text{HCl)} \\ = M_S \times A_T/A_S \times 2/5$$

M_S : Amount (mg) of Donepezil Hydrochloride RS taken, calculated on the anhydrous basis

Operating conditions—

Proceed as directed in the operating conditions in the Assay under Donepezil Hydrochloride.

System suitability—

System performance: When the procedure is run with 20 μ L of the standard solution under the above operating conditions, the number of theoretical plates and the symmetry factor of the peak of donepezil are not less than 5000 and not more than 1.5, respectively.

System repeatability: When the test is repeated 6 times with 20 μ L of the standard solution under the above operating conditions, the relative standard deviation of the peak area of donepezil is not more than 1.0%.

Containers and storage Containers—Well-closed containers.

Dopamine Hydrochloride

ドパミン塩酸塩

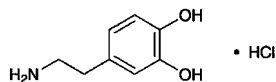

$C_8H_{11}NO_2 \cdot HCl$: 189.64

4-(2-Aminoethyl)benzene-1,2-diol monohydrochloride
[62-31-7]

Dopamine Hydrochloride, when dried, contains not less than 98.5% of dopamine hydrochloride ($C_8H_{11}NO_2 \cdot HCl$).

Description Dopamine Hydrochloride occurs as white, crystals or crystalline powder.

It is freely soluble in water and in formic acid, and sparingly soluble in ethanol (95).

Melting point: about 248°C (with decomposition).

Identification (1) Determine the absorption spectrum of a solution of Dopamine Hydrochloride in 0.1 mol/L hydrochloric acid TS (1 in 25,000) as directed under Ultraviolet-visible Spectrophotometry <2.24>, and compare the spectrum with the Reference Spectrum: both spectra exhibit similar intensities of absorption at the same wavelengths.

(2) Determine the infrared absorption spectrum of Dopamine Hydrochloride as directed in the potassium chloride disk method under Infrared Spectrophotometry <2.25>, and compare the spectrum with the Reference Spectrum: both spectra exhibit similar intensities of absorption at the same wave numbers.

(3) A solution of Dopamine Hydrochloride (1 in 50) responds to Qualitative Tests <1.09> (1) for chloride.

pH <2.54> Dissolve 1.0 g of Dopamine Hydrochloride in 50 mL of water: the pH of this solution is between 4.0 and 5.5.

Purity (1) Clarity and color of solution—Dissolve 1.0 g of Dopamine Hydrochloride in 10 mL of water: the solution is clear and colorless.

(2) Sulfate <1.14>—Perform the test with 0.8 g of Dopamine Hydrochloride. Prepare the control solution with 0.35 mL of 0.005 mol/L sulfuric acid VS (not more than 0.021%).

(3) Heavy metals <1.07>—Proceed with 1.0 g of Dopamine Hydrochloride according to Method 1, and perform the test. Prepare the control solution with 2.0 mL of Standard Lead Solution (not more than 20 ppm).

(4) Arsenic <1.11>—Prepare the test solution with 1.0 g of Dopamine Hydrochloride according to Method 1, and perform the test (not more than 2 ppm).

(5) Related substances—Dissolve 0.1 g of Dopamine Hydrochloride in 10 mL of water, and use this solution as the sample solution. Pipet 1 mL of the sample solution, add water to make exactly 250 mL, and use this solution as the standard solution. Perform the test with these solutions as directed under Thin-layer Chromatography <2.03>. Spot 5 μ L each of the sample solution and standard solution on a plate of cellulose with fluorescent indicator for thin-layer chromatography. Develop the plate with a mixture of 1-propanol, water and acetic acid (100) (16:8:1) to a distance of about 10 cm, and air-dry the plate. Spray evenly a solution of ninhydrin in acetone (1 in 50) on the plate, and heat the plate at 90°C for 10 minutes: the spots other than the principal spot obtained from the sample solution are not

more intense than the spot from the standard solution.

Loss on drying <2.41> Not more than 0.5% (1 g, 105°C, 3 hours).

Residue on ignition <2.44> Not more than 0.1% (1 g).

Assay Weigh accurately about 0.2 g of Dopamine Hydrochloride, previously dried, dissolve in 5 mL of formic acid, add exactly 15 mL of 0.1 mol/L perchloric acid VS, and heat on a water bath for 15 minutes. After cooling, add 50 mL of acetic acid (100), and titrate <2.50> the excess perchloric acid with 0.1 mol/L sodium acetate VS (potentiometric titration). Perform a blank determination in the same manner.

Each mL of 0.1 mol/L perchloric acid VS
= 18.96 mg of $C_8H_{11}NO_2 \cdot HCl$

Containers and storage Containers—Tight containers.

Dopamine Hydrochloride Injection

ドパミン塩酸塩注射液

Dopamine Hydrochloride Injection is an aqueous injection.

It contains not less than 97.0% and not more than 103.0% of the labeled amount of dopamine hydrochloride ($C_8H_{11}NO_2 \cdot HCl$: 189.64).

Method of preparation Prepare as directed under Injections, with Dopamine Hydrochloride.

Description Dopamine Hydrochloride Injection occurs as a clear, colorless liquid.

Identification To a volume of Dopamine Hydrochloride Injection, equivalent to 0.04 g of Dopamine Hydrochloride, add 0.1 mol/L hydrochloric acid TS to make 100 mL. To 5 mL of this solution add 0.1 mol/L hydrochloric acid TS to make 50 mL. Determine the absorption spectrum of this solution as directed under Ultraviolet-visible Spectrophotometry <2.24>: it exhibits a maximum between 278 nm and 282 nm.

pH <2.54> 3.0 – 5.0

Bacterial endotoxins <4.01> Less than 4.2 EU/mg.

Extractable volume <6.05> It meets the requirement.

Foreign insoluble matter <6.06> Perform the test according to Method 1: it meets the requirement.

Insoluble particulate matter <6.07> It meets the requirement.

Sterility <4.06> Perform the test according to the Membrane filtration method: it meets the requirement.

Assay To an exact volume of Dopamine Hydrochloride Injection, equivalent to about 30 mg of dopamine hydrochloride ($C_8H_{11}NO_2 \cdot HCl$), add the mobile phase to make exactly 50 mL. Pipet 2.5 mL of this solution, add exactly 2.5 mL of the internal standard solution and the mobile phase to make 20 mL, and use this solution as the sample solution. Separately, weigh accurately about 30 mg of dopamine hydrochloride for assay, previously dried at 105°C for 3 hours, dissolve in the mobile phase to make exactly 50 mL. Pipet 2.5 mL of this solution, add exactly 2.5 mL of the internal standard solution and the mobile phase to make 20 mL, and use this solution as the standard solution. Perform the test with 10 μ L each of the sample solution and standard solution

as directed under Liquid Chromatography <2.01> according to the following conditions, and calculate the ratios, Q_T and Q_S , of the peak area of dopamine to that of the internal standard.

$$\text{Amount (mg) of dopamine hydrochloride (C}_8\text{H}_{11}\text{NO}_2\cdot\text{HCl)} \\ = M_S \times Q_T/Q_S$$

M_S : Amount (mg) of dopamine hydrochloride for assay taken

Internal standard solution—A solution of uracil in the mobile phase (3 in 10,000).

Operating conditions—

Detector: An ultraviolet absorption photometer (wavelength: 280 nm).

Column: A stainless steel column 4.6 mm in inside diameter and 25 cm in length, packed with octadecylsilanized silica gel for liquid chromatography (5 μm in particle diameter).

Column temperature: A constant temperature of about 25°C.

Mobile phase: Disodium hydrogen phosphate-citric acid buffer solution (pH 3.0).

Flow rate: Adjust so that the retention time of dopamine is about 10 minutes.

System suitability—

System performance: When the procedure is run with 10 μL of the standard solution under the above operating conditions, the internal standard and dopamine are eluted in this order with the resolution between these peaks being not less than 10.

System repeatability: When the test is repeated 6 times with 10 μL of the standard solution under the above operating conditions, the relative standard deviation of the ratios of peak area of dopamine to that of the internal standard is not more than 1.0%.

Containers and storage Containers—Hermetic containers.

Plastic containers for aqueous injections may be used.

Doripenem Hydrate

ドリペネム水和物

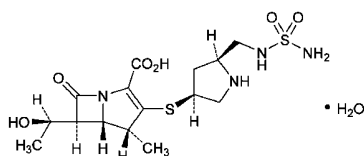

$\text{C}_{15}\text{H}_{24}\text{N}_4\text{O}_6\text{S}_2\cdot\text{H}_2\text{O}$: 438.52

(4*R*,5*S*,6*S*)-6-[(1*R*)-1-Hydroxyethyl]-4-methyl-7-oxo-3-[(3*S*,5*S*-5-[(sulfamoylamino)methyl]pyrrolidin-3-yl)sulfanyl]-1-azabicyclo[3.2.0]hept-2-ene-2-carboxylic acid monohydrate
[364622-82-2]

Doripenem Hydrate contains not less than 970 μg (potency) and not more than 1020 μg (potency) per mg, calculated on the anhydrous basis. The potency of Doripenem Hydrate is expressed as mass (potency) of doripenem ($\text{C}_{15}\text{H}_{24}\text{N}_4\text{O}_6\text{S}_2$: 420.50).

Description Doripenem Hydrate occurs as a white to pale yellow-brown-white crystalline powder.

It is sparingly soluble in water, slightly soluble in methanol, and practically insoluble in ethanol (99.5).

It is gradually colored to pale yellow-brown-white by light.

Identification (1) Determine the absorption spectrum of a

solution of Doripenem Hydrate (1 in 50,000) as directed under Ultraviolet-visible Spectrophotometry <2.24>, and compare the spectrum with the Reference Spectrum or the spectrum of a solution of Doripenem RS prepared in the same manner as the sample solution: both spectra exhibit similar intensities of absorption at the same wavelengths.

(2) Determine the infrared absorption spectrum of Doripenem Hydrate as directed in the potassium bromide disk method under Infrared Spectrophotometry <2.25>, and compare the spectrum with the Reference Spectrum or the spectrum of Doripenem RS: both spectra exhibit similar intensities of absorption at the same wave numbers.

Optical rotation <2.49> $[\alpha]_D^{20}$: +33 – +38° (0.25 g calculated on the anhydrous basis, water, 25 mL, 100 mm).

pH <2.54> Dissolve 0.3 g of Doripenem Hydrate in 30 mL of water: the pH of the solution is between 4.5 and 6.0.

Purity (1) Clarity and color of solution—Dissolve 0.2 g of Doripenem Hydrate in 20 mL of water, and perform the test with this solution as directed under Turbidity Measurement <2.61>: the solution is clear. Perform the test with this solution according to Method 2 under Methods for Color Matching <2.65>: the solution is not more colored than Matching Fluid Y4.

(2) Heavy metals <1.07>—Moisten 1.0 g of Doripenem Hydrate with sulfuric acid, cover loosely, and heat gently to carbonize. Then proceed according to Method 2, and perform the test. Prepare the control solution with 2.0 mL of Standard Lead Solution (not more than 20 ppm).

(3) Related substances (i)—Dissolve 20 mg of Doripenem Hydrate in 10 mL of water, and use this solution as the sample solution. Pipet 1 mL of the sample solution, add water to make exactly 100 mL, and use this solution as the standard solution. Perform the test with exactly 20 μL each of the sample solution and standard solution as directed under Liquid Chromatography <2.01> according to the following conditions. Determine each peak area by the automatic integration method: the peak areas of related substance A, having the relative retention time of about 2.2 to doripenem, related substance B, having the relative retention time of about 2.5, and related substance C, having the relative retention time of about 3.2, obtained from the sample solution, are not larger than 1/10 times the peak area of doripenem from the standard solution, and the area of the peak other than doripenem, the peaks mentioned above and the peak having the relative retention time of about 2.1, from the sample solution, is not larger than 1/20 times the peak area of doripenem from the standard solution. Furthermore, the total area of the peaks other than doripenem and the peak having the relative retention time of about 2.1 from the sample solution is not larger than 1/2 times the peak area of doripenem from the standard solution.

Operating conditions—

Detector: An ultraviolet absorption photometer (wavelength: 230 nm).

Column: A stainless steel column 4.6 mm in inside diameter and 15 cm in length, packed with octadecylsilanized silica gel for liquid chromatography (5 μm in particle diameter).

Column temperature: A constant temperature of about 30°C.

Mobile phase A: Dissolve 2.04 g of potassium dihydrogen phosphate in water to make 1000 mL, and adjust to pH 5.6 – 5.7 with a solution prepared by dissolving 2.61 g of dipotassium hydrogen phosphate in water to make 1000 mL. To 970 mL of this solution add 30 mL of acetonitrile for liquid chromatography.

Mobile phase B: Dissolve 2.04 g of potassium dihydrogen phosphate in water to make 1000 mL, and adjust to pH 5.6 – 5.7 with a solution prepared by dissolving 2.61 g of dipotassium hydrogen phosphate in water to make 1000 mL. To 700 mL of this solution add 300 mL of acetonitrile for liquid chromatography.

Flowing of mobile phase: Control the gradient by mixing the mobile phases A and B as directed in the following table.

Time after injection of sample (min)	Mobile phase A (vol%)	Mobile phase B (vol%)
0 – 15	100	0
15 – 45	100 → 50	0 → 50
45 – 50	50 → 0	50 → 100
50 – 55	0	100

Flow rate: 1.0 mL per minute.

Time span of measurement: For 55 minutes after injection, beginning after the peak having the relative retention time of about 0.2 to doripenem.

System suitability—

Test for required detectability: Pipet 1.5 mL of the standard solution, and add water to make exactly 50 mL. Confirm that the peak area of doripenem obtained with 20 μ L of this solution is equivalent to 2.1 to 3.9% of that with 20 μ L of the standard solution.

System performance: When the procedure is run with 20 μ L of the standard solution under the above operating conditions, the number of theoretical plates and the symmetry factor of the peak of doripenem are not less than 5000 and not more than 1.3, respectively.

System repeatability: When the test is repeated 3 times with 20 μ L of the standard solution under the above operating conditions, the relative standard deviation of the peak area of doripenem is not more than 0.95%.

(ii) Dissolve 20 mg of Doripenem Hydrate in 10 mL of water, and use this solution as the sample solution. Pipet 1 mL of the sample solution, and add water to make exactly 100 mL, and use this solution as the standard solution. Perform the test with exactly 20 μ L each of the sample solution and standard solution as directed under Liquid Chromatography <2.01> according to the following conditions. Determine each peak area by the automatic integration method: the peak area of related substance D, having the relative retention time of about 0.5 to doripenem, obtained from the sample solution is not larger than 2/5 times the peak area of doripenem from the standard solution.

Operating conditions—

Detector: An ultraviolet absorption photometer (wavelength: 215 nm).

Column: A stainless steel column 4.6 mm in inside diameter and 15 cm in length, packed with octadecyl-strong anion exchange-silanized silica gel for liquid chromatography (5 μ m in particle diameter).

Column temperature: A constant temperature of about 40°C.

Mobile phase: To 9 mL of phosphoric acid add 200 mL of water, add 20 mL of triethylamine, and add water to make 2000 mL. Adjust to pH 5.7 – 5.9 with phosphoric acid. To 950 mL of this solution add 50 mL of acetonitrile for liquid chromatography.

Flow rate: Adjust so that the retention time of doripenem is about 10 minutes.

System suitability—

Test for required detectability: Pipet 2 mL of the standard

solution, and add water to make exactly 20 mL. Confirm that the peak area of doripenem obtained with 20 μ L of this solution is equivalent to 7 to 13% of that with 20 μ L of the standard solution.

System performance: To 1 mL of the sample solution add 1 mL of 0.1 mol/L hydrochloric acid TS, allow to stand at 25 \pm 5°C for 15 minutes, and add water to make 100 mL. When the procedure is run with 20 μ L of this solution under the above operating conditions, related substance D and doripenem are eluted in this order with the resolution between these peaks being not less than 5. The number of theoretical plates and the symmetry factor of the peak of related substance D are not less than 300 and 0.7 to 1.3, respectively, and those of the peak of doripenem are not less than 5000 and 0.7 to 1.3, respectively.

System repeatability: When the test is repeated 6 times with 20 μ L of the standard solution under the above operating conditions, the relative standard deviation of the peak area of doripenem is not more than 2.0%.

(iii) Dissolve 20 mg of Doripenem Hydrate in 10 mL of water, and use this solution as the sample solution. Pipet 1 mL of the sample solution, add water to make exactly 100 mL, and use this solution as the standard solution. Perform the test with exactly 20 μ L each of the sample solution and standard solution as directed under Liquid Chromatography <2.01> according to the following conditions. Determine each peak area by the automatic integration method: the areas of the peaks, having the relative retention time of about 1.8, about 2.2 and about 2.3 to doripenem, obtained from the sample solution are not larger than 1/20, 7/100 and 1/20 times the peak area of doripenem from the standard solution, respectively.

Operating conditions—

Detector: An ultraviolet absorption photometer (wavelength: 310 nm).

Column: A stainless steel column 4.6 mm in inside diameter and 25 cm in length, packed with octadecylsilanized silica gel for liquid chromatography (3 μ m in particle diameter).

Column temperature: A constant temperature of about 30°C.

Mobile phase A: To 11 mL of perchloric acid add water to make 500 mL. To 100 mL of this solution add water to make 1000 mL. To 600 mL of this solution add 100 mL of water, and adjust to pH 1.9 – 2.0 with a solution prepared by adding water to 2.81 g of sodium perchlorate monohydrate to make 1000 mL. To 900 mL of this solution add 100 mL of acetonitrile.

Mobile phase B: To 11 mL of perchloric acid add water to make 500 mL. To 100 mL of this solution add water to make 1000 mL. To 600 mL of this solution add 100 mL of water, and adjust to pH 1.9 – 2.0 with a solution prepared by adding water to 2.81 g of sodium perchlorate monohydrate to make 1000 mL. To 300 mL of this solution add 200 mL of acetonitrile.

Flowing of mobile phase: Control the gradient by mixing the mobile phases A and B as directed in the following table.

Time after injection of sample (min)	Mobile phase A (vol%)	Mobile phase B (vol%)
0 – 25	100	0
25 – 55	100 → 0	0 → 100
55 – 60	0	100

Flow rate: 0.8 mL per minute.

System suitability—

Test for required detectability: Pipet 2.5 mL of the standard solution, and add water to make exactly 50 mL. Confirm that the peak area of doripenem obtained with 20 μ L of this solution is equivalent to 3.5 to 6.5% of that with 20 μ L of the standard solution.

System performance: When the procedure is run with 20 μ L of the standard solution under the above operating conditions, the number of theoretical plates and the symmetry factor of the peak of doripenem are not less than 15,000 and not more than 1.3, respectively.

System repeatability: When the test is repeated 3 times with 20 μ L of the standard solution under the above operating conditions, the relative standard deviation of the peak area of doripenem is not more than 0.95%.

Water <2.48> 4.0 – 5.0% (0.3 g, volumetric titration, back titration).

Residue on ignition <2.44> Not more than 0.1% (1 g).

Assay Weigh accurately amounts of Doripenem Hydrate and Doripenem RS (separately determine the water <2.48> in the same manner as Doripenem Hydrate), equivalent to about 25 mg (potency), dissolve each in water to make exactly 200 mL, and use these solutions as the sample solution and the standard solution, respectively. Perform the test with exactly 10 μ L each of the sample solution and standard solution as directed under Liquid Chromatography <2.01> according to the following conditions, and determine the peak areas, A_T and A_S , of doripenem in each solution.

$$\text{Amount } [\mu\text{g (potency)}] \text{ of doripenem } (\text{C}_{15}\text{H}_{24}\text{N}_4\text{O}_6\text{S}_2) \\ = M_S \times A_T / A_S \times 1000$$

M_S : Amount [mg (potency)] of Doripenem RS taken, calculated on the anhydrous basis

Operating conditions—

Detector: An ultraviolet absorption photometer (wavelength: 300 nm).

Column: A stainless steel column 4.6 mm in inside diameter and 15 cm in length, packed with octadecylsilanized silica gel for liquid chromatography (5 μ m in particle diameter).

Column temperature: A constant temperature of about 25°C.

Mobile phase: Adjust the pH of 90 mL of 0.02 mol/L potassium dihydrogen phosphate TS to pH 5.6 – 5.7 with a solution prepared by dissolving 3.48 g of dipotassium hydrogen phosphate in water to make 1000 mL. To 100 mL of this solution add water to make exactly 1000 mL. To 970 mL of this solution add 30 mL of acetonitrile.

Flow rate: Adjust so that the retention time of doripenem is about 15 minutes.

System suitability—

System performance: When the procedure is run with 10 μ L of the standard solution under the above operating conditions, the number of theoretical plates and the symmetry factor of the peak of doripenem are not less than 5000 and not more than 1.3, respectively.

System repeatability: When the test is repeated 6 times with 10 μ L of the standard solution under the above operating conditions, the relative standard deviation of the peak area of doripenem is not more than 1.0%.

Containers and storage Containers—Tight containers.

Storage—At a temperature between 2°C and 8°C.

Others

Related substance A:

(4*R*,5*S*,6*S*)-3-[(3*S*,5*S*)-5-[(*N*-(*E*-

(Dimethylamino)methylene]sulfamoyl]amino)methyl]pyrrolidin-3-ylsulfanyl]-6-[(1*R*)-1-hydroxyethyl]-4-methyl-7-oxo-1-azabicyclo[3.2.0]hept-2-ene-2-carboxylic acid

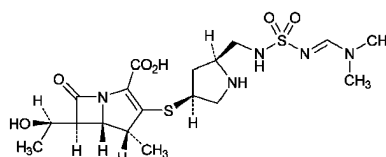

Related substance B:

(1*S*,4*S*,5*S*,6*R*)-4-[(1*R*)-1-Hydroxyethyl]-8-[(4*R*,5*S*,6*S*)-6-[(1*R*)-1-hydroxyethyl]-4-methyl-7-oxo-3-[(3*S*,5*S*)-5-[(sulfamoylamino)methyl]pyrrolidin-3-ylsulfanyl]-1-azabicyclo[3.2.0]hept-2-ene-2-carbonyl]-6-methyl-3-oxo-7-[(3*S*,5*S*)-5-[(sulfamoylamino)methyl]pyrrolidin-3-ylsulfanyl]-2-oxa-8-azabicyclo[3.2.1]octane-1-carboxylic acid

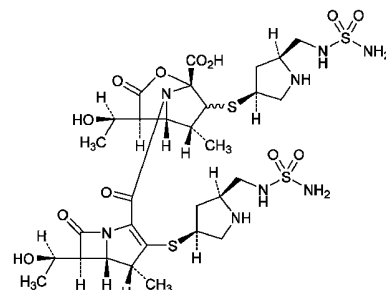

Related substance C:

(4*R*,5*S*,6*S*)-3-[(3*S*,5*S*)-5-[(*N*-(1,1-Dimethylethyl)sulfamoyl]amino)methyl]pyrrolidin-3-ylsulfanyl]-6-[(1*R*)-1-hydroxyethyl]-4-methyl-7-oxo-1-azabicyclo[3.2.0]hept-2-ene-2-carboxylic acid

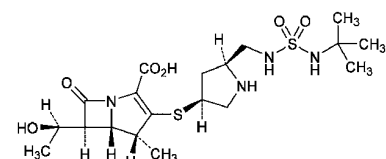

Related substance D:

(2*S*,3*R*,4*S*)-2-[(1*S*,2*R*)-1-Carboxy-2-hydroxypropyl]-3-methyl-4-[(3*S*,5*S*)-5-[(sulfamoylamino)methyl]pyrrolidin-3-ylsulfanyl]-3,4-dihydro-2*H*-pyrrole-5-carboxylic acid

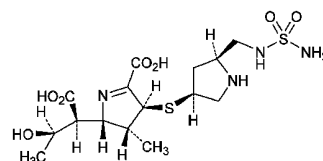
**Doripenem for Injection**

注射用ドリベネム

Doripenem for Injection is a preparation for injection, which is dissolved before use.

It contains not less than 95.0% and not more than 105.0% of the labeled potency of doripenem ($\text{C}_{15}\text{H}_{24}\text{N}_4\text{O}_6\text{S}_2$; 420.50).

Method of preparation Prepare as directed under Injections, with Doripenem Hydrate.

Description Doripenem for Injection occurs as a white to pale yellow-brown-white crystalline powder.

Identification Proceed as directed in the Identification (2) under Doripenem Hydrate.

pH <2.54> Dissolve an amount of Doripenem for Injection, equivalent to 0.3 g (potency) of Doripenem Hydrate, in 30 mL of water: the pH of the solution is between 4.5 and 6.0.

Purity (1) Clarity and color of solution—Dissolve an amount of Doripenem for Injection, equivalent to 0.2 g (potency) of Doripenem Hydrate in 20 mL of water, and proceed as directed in the Purity (1) under Doripenem Hydrate.

(2) Related substances—(i) Dissolve an amount of Doripenem for Injection, equivalent to 20 mg (potency) of Doripenem Hydrate, in 10 mL of water, and use this solution as the sample solution. Pipet 1 mL of the sample solution, add water to make exactly 100 mL, and use this solution as the standard solution. Perform the test with exactly 20 μ L each of the sample solution and standard solution as directed under Liquid Chromatography <2.01> according to the following conditions, and determine each peak area by the automatic integration method: the area of the peak other than doripenem and the peak having the relative retention time of about 2.1 to doripenem, related substance A having the relative retention time of about 2.2, related substance B having the relative retention time of about 2.5 and related substance C having the relative retention time of about 3.2, obtained from the sample solution, is not larger than 1/10 times the peak area of doripenem from the standard solution, and the total area of the peaks other than doripenem and the peak mentioned above from the sample solution is not larger than 1/2 times the peak area of doripenem from the standard solution.

Operating conditions—

Proceed as directed in the operating conditions in the Purity (3) (i) under Doripenem Hydrate.

System suitability—

Test for required detectability: Pipet 2.5 mL of the standard solution, and add water to make exactly 50 mL. Confirm that the peak area of doripenem obtained with 20 μ L of this solution is equivalent to 3.5 to 6.5% of that with 20 μ L of the standard solution.

System performance: When the procedure is run with 20 μ L of the standard solution under the above operating conditions, the number of theoretical plates and the symmetry factor of the peak of doripenem are not less than 5000 and not more than 1.3, respectively.

System repeatability: When the test is repeated 3 times with 20 μ L of the standard solution under the above operating conditions, the relative standard deviation of the peak area of doripenem is not more than 0.95%.

(ii) Dissolve an amount of Doripenem for Injection, equivalent to 20 mg (potency) of Doripenem Hydrate, in 10 mL of water, and use this solution as the sample solution. Pipet 1 mL of the sample solution, add water to make exactly 100 mL, and use this solution as the standard solution. Perform the test with exactly 20 μ L each of the sample solution and standard solution as directed under Liquid Chromatography <2.01> according to the following conditions. Determine each peak area by the automatic integration method: the peak area of related substance D, having the relative retention time of about 0.5 to doripenem, obtained from the sample solution is not larger than the peak area of doripenem from the standard solution.

Operating conditions—

Proceed as directed in the operating conditions in the Purity (3) (ii) under Doripenem Hydrate.

System suitability—

System performance: To 1 mL of the sample solution add 1 mL of 0.1 mol/L hydrochloric acid TS, allow to stand at $25 \pm 5^\circ\text{C}$ for 15 minutes, and add water to make 100 mL. When the procedure is run with 20 μ L of this solution under the above operating conditions, related substance D and doripenem are eluted in this order with the resolution between these peaks being not less than 5. The number of theoretical plates and the symmetry factor of the peak of related substance D are not less than 300 and 0.7 to 1.3, respectively, and those of the peak of doripenem are not less than 5000 and 0.7 to 1.3, respectively.

System repeatability: When the test is repeated 6 times with 20 μ L of the standard solution under the above operating conditions, the relative standard deviation of the peak area of doripenem is not more than 2.0%.

Water <2.48> 4.0 – 5.0% (0.3 g, volumetric titration, back titration).

Bacterial endotoxins <4.01> Less than 0.25 EU/mg (potency).

Uniformity of dosage units <6.02> It meets the requirement of the Mass variation test.

Foreign insoluble matter <6.06> Perform the test according to Method 2: it meets the requirement.

Insoluble particulate matter <6.07> It meets the requirement.

Sterility <4.06> Perform the test according to the Membrane filtration method: it meets the requirement.

Assay Weigh accurately the mass of the contents of not less than 10 containers of Doripenem for Injection. Weigh accurately an amount of the contents, equivalent to about 25 mg (potency) of Doripenem Hydrate, dissolve in water to make exactly 200 mL, and use this solution as the sample solution. Separately, weigh accurately about 25 mg (potency) of Doripenem RS (separately determine the water <2.48> in the same manner as Doripenem Hydrate), dissolve in water to make exactly 200 mL, and use this solution as the standard solution. Then, proceed as directed in the Assay under Doripenem Hydrate.

$$\begin{aligned} &\text{Amount } [\mu\text{g (potency)}] \text{ of doripenem (C}_{15}\text{H}_{24}\text{N}_4\text{O}_6\text{S}_2) \\ &= M_S \times A_T/A_S \times 1000 \end{aligned}$$

M_S : Amount [mg (potency)] of Doripenem RS taken, calculated on the anhydrous basis

Containers and storage Containers—Hermetic containers. Plastic containers for aqueous injections may be used.

Others

Related substances A, B, C and D: Refer to them described in Doripenem Hydrate.

Dorzolamide Hydrochloride

ドルゾラミド塩酸塩

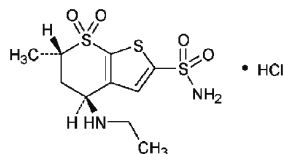

$C_{10}H_{16}N_2O_4S_3 \cdot HCl$: 360.90
 (4*S*,6*S*)-4-Ethylamino-6-methyl-5,6-dihydro-4*H*-thieno[2,3-*b*]thiopyran-2-sulfonamide 7,7-dioxide monohydrochloride
 [130693-82-2]

Dorzolamide Hydrochloride contains not less than 99.0% and not more than 101.0% of dorzolamide hydrochloride ($C_{10}H_{16}N_2O_4S_3 \cdot HCl$), calculated on the anhydrous basis.

Description Dorzolamide Hydrochloride occurs as a white crystalline powder.

It is soluble in water, sparingly soluble in methanol, and very slightly soluble in ethanol (99.5).

It dissolves in diluted ammonia solution (28) (13 in 400).

Optical rotation $[\alpha]_{404.7}^{25}$: $-16.0 - -17.5^\circ$ (0.25 g calculated on the anhydrous basis, water, 25 mL, 100 mm).

Dorzolamide Hydrochloride shows crystal polymorphism.

Identification (1) Determine the absorption spectrum of a solution of Dorzolamide Hydrochloride in a solution of hydrochloric acid in methanol (9 in 1000) (3 in 200,000) as directed under Ultraviolet-visible Spectrophotometry <2.24>, and compare the spectrum with the Reference Spectrum or the spectrum of a solution of Dorzolamide Hydrochloride RS prepared in the same manner as the sample solution: both spectra exhibit similar intensities of absorption at the same wavelengths.

(2) Determine the infrared absorption spectrum of Dorzolamide Hydrochloride as directed in the potassium bromide disk method under Infrared Spectrophotometry <2.25>, and compare the spectrum with the Reference Spectrum or the spectrum of Dorzolamide Hydrochloride RS: both spectra exhibit similar intensities of absorption at the same wave numbers.

(3) A solution of Dorzolamide Hydrochloride (1 in 100) responds to Qualitative Tests <1.09> for chloride.

Purity (1) Heavy metals <1.07>—Proceed with 2.0 g of Dorzolamide Hydrochloride according to Method 2, and perform the test. Prepare the control solution with 2.0 mL of Standard Lead Solution (not more than 10 ppm).

(2) Related substances—Dissolve 30 mg of Dorzolamide Hydrochloride in 50 mL of a mixture of water and methanol (4:1), and use this solution as the sample solution. Perform the test with 10 μ L of the sample solution as directed under Liquid Chromatography <2.01> according to the following conditions. Determine each peak area by the automatic integration method, and calculate their amounts by the area percentage method: the amount of the peaks other than dorzolamide is not more than 0.1%.

Operating conditions—

Detector, column, column temperature, and flow rate: Proceed as directed in the operating conditions in the Assay.

Mobile phase A: Adjust to pH 4.5 of a mixture of water and acetic acid (100) (1000:1) with triethylamine.

Mobile phase B: Acetonitrile.

Flowing of mobile phase: Control the gradient by mixing the mobile phases A and B as directed in the following table.

Time after injection of sample (min)	Mobile phase A (vol%)	Mobile phase B (vol%)
0 – 10	100	0
10 – 30	100 → 50	0 → 50

Time span of measurement: About 3 times as long as the retention time of dorzolamide, beginning after the solvent peak.

System suitability—

Test for required detectability: Pipet 2 mL of the sample solution, and add a mixture of water and methanol (4:1) to make exactly 100 mL. Pipet 1 mL of this solution, add a mixture of water and methanol (4:1) to make exactly 20 mL, and use this solution as the solution for system suitability test. Confirm that the peak area of dorzolamide obtained with 10 μ L of the solution for system suitability test is equivalent to 0.07 to 0.13% of that with 10 μ L of the sample solution.

System performance: To 1 mL of the sample solution add 2 mL of a mixture of water and methanol (4:1). When the procedure is run with 10 μ L of this solution under the above operating conditions, the number of theoretical plates and the symmetry factor of the peak of dorzolamide are not less than 4000 and not more than 1.5, respectively.

System repeatability: When the test is repeated 6 times with 10 μ L of the solution for system suitability test under the above operating conditions, the relative standard deviation of the peak area of dorzolamide is not more than 7%.

(3) Enantiomer—Dissolve 20 mg of Dorzolamide Hydrochloride in 4 mL of diluted ammonia solution (28) (13 in 400), and extract this solution with two 4-mL portions of ethyl acetate. Combine the extracts, and evaporate the ethyl acetate at 50°C under a current of nitrogen. Dissolve the residue in 3 mL of acetonitrile, add 3 drops of (*S*)-1-phenylethyl isocyanate, and allow to stand at 50°C for 10 minutes. Evaporate at 50°C under a current of nitrogen, dissolve the residue in 10 mL of a mixture of *tert*-butylmethyl ether, acetic acid (100) and acetonitrile (873:100:27), and use this solution as the sample solution. Perform the test with 5 μ L of the sample solution as directed under Liquid Chromatography <2.01> according to the following conditions, and determine the peak areas of dorzolamide, A_2 , and that of the enantiomer, having the relative retention time of about 1.5 to dorzolamide, A_1 , by the automatic integration method: the result of $A_1/(A_1 + A_2)$ is not more than 0.005.

Operating conditions—

Detector: An ultraviolet absorption photometer (wavelength: 254 nm).

Column: A stainless steel column 4.6 mm in inside diameter and 25 cm in length, packed with silica gel for liquid chromatography (5 μ m in particle diameter).

Column temperature: A constant temperature of about 25°C.

Mobile phase: To a mixture of 30 mL of acetonitrile and 3 mL of water add *tert*-butylmethyl ether to make 1000 mL. To 650 mL of this solution add 350 mL of heptane.

Flow rate: Adjust so that the retention time of dorzolamide is about 8 minutes.

System suitability—

Test for required detectability: Pipet 1 mL of the sample solution, add a mixture of *tert*-butylmethyl ether, acetic acid

(100) and acetonitrile (873:100:27) to make exactly 200 mL, and use this solution as the solution for system suitability test. Confirm that the peak area of dorzolamide obtained with 5 μ L of the solution for system suitability test is equivalent to 0.4 to 0.6% of that with 5 μ L of the sample solution.

System performance: When the procedure is run with 5 μ L of the sample solution under the above operating conditions, the number of theoretical plates and the symmetry factor of the peak of dorzolamide are not less than 4000 and not more than 1.4, respectively.

System repeatability: When the test is repeated 6 times with 5 μ L of the solution for system suitability test under the above operating conditions, the relative standard deviation of the peak area of dorzolamide is not more than 7%.

Water <2.48> Not more than 0.5% (0.5 g, coulometric titration).

Residue on ignition <2.44> Not more than 0.1% (1 g).

Assay Weigh accurately about 20 mg each of Dorzolamide Hydrochloride and Dorzolamide Hydrochloride RS (separately, determine the water <2.48> in the same manner as Dorzolamide Hydrochloride), dissolve in a mixture of water and methanol (4:1) to make exactly 100 mL, and use these solutions as the sample solution and the standard solution, respectively. Perform the test with exactly 10 μ L each of the sample solution and standard solution as directed under Liquid Chromatography <2.01> according to the following conditions, and determine the peak areas, A_T and A_S , of dorzolamide in each solution.

$$\begin{aligned} & \text{Amount (mg) of dorzolamide hydrochloride} \\ & (\text{C}_{10}\text{H}_{16}\text{N}_2\text{O}_4\text{S}_3 \cdot \text{HCl}) \\ & = M_S \times A_T / A_S \end{aligned}$$

M_S : Amount (mg) of Dorzolamide Hydrochloride RS taken, calculated on the anhydrous basis

Operating conditions—

Detector: An ultraviolet absorption photometer (wavelength: 254 nm).

Column: A stainless steel column 4.6 mm in inside diameter and 8.3 cm in length, packed with octylsilylanized silica gel for liquid chromatography (3 μ m in particle diameter).

Column temperature: A constant temperature of about 25°C.

Mobile phase: Adjust to pH 4.5 of a mixture of water and acetic acid (100) (1000:1) with triethylamine.

Flow rate: Adjust so that the retention time of dorzolamide is about 9 minutes.

System suitability—

System performance: When the procedure is run with 10 μ L of the standard solution under the above operating conditions, the number of theoretical plates and the symmetry factor of the peak of dorzolamide are not less than 4000 and not more than 1.5, respectively.

System repeatability: When the test is repeated 6 times with 10 μ L of the standard solution under the above operating conditions, the relative standard deviation of the peak area of dorzolamide is not more than 1.0%.

Containers and storage Containers—Well-closed containers.

Dorzolamide Hydrochloride Ophthalmic Solution

ドルゾラミド塩酸塩点眼液

Dorzolamide Hydrochloride Ophthalmic Solution is an aqueous ophthalmic preparation.

It contains not less than 95.0% and not more than 107.0% of the labeled amount of dorzolamide ($\text{C}_{10}\text{H}_{16}\text{N}_2\text{O}_4\text{S}_3$: 324.44).

Method of preparation Prepare as directed under Ophthalmic Liquids and Solutions, with Dorzolamide Hydrochloride.

Description Dorzolamide Hydrochloride Ophthalmic Solution occurs as a clear and colorless liquid.

Identification To a volume of Dorzolamide Hydrochloride Ophthalmic Solution, equivalent to about 1.2 mg of dorzolamide ($\text{C}_{10}\text{H}_{16}\text{N}_2\text{O}_4\text{S}_3$), add 0.1 mol/L hydrochloric acid TS to make 100 mL. Determine the absorption spectrum of this solution as directed under Ultraviolet-visible Spectrophotometry <2.24>: it exhibits a maximum between 252 nm and 256 nm.

pH Being specified separately when the drug is granted approval based on the Law.

Purity cis-Isomer—Use the sample solution obtained in the Assay as the sample solution. Perform the test with 20 μ L of the sample solution as directed under Liquid Chromatography <2.01> according to the following conditions, and determine the peak area of dorzolamide, A_2 , and that of cis-isomer, having the relative retention time of about 1.1 to dorzolamide, A_1 , by the automatic integration method: $A_1 / (A_1 + A_2)$ is not larger than 0.020.

Diluting solution: To 2 mL of phosphoric acid add 900 mL of water, adjust to pH 3.0 with triethylamine, then add water to make 1000 mL.

Operating conditions—

Proceed as directed in the operating conditions in the Assay.

System suitability—

System performance: Proceed as directed in the system suitability in the Assay.

Test for required detectability: To exactly 2 mL of the sample solution add the diluting solution to make exactly 100 mL. Pipet 1 mL of this solution, add the diluting solution to make exactly 20 mL, and use this solution as the solution for system suitability test. Confirm that the peak area of dorzolamide obtained with 20 μ L of the solution for system suitability test is equivalent to 0.07 to 0.13% of that with 20 μ L of the sample solution.

System repeatability: When the test is repeated 6 times with 20 μ L of the solution for system suitability test under the above operating conditions, the relative standard deviation of the peak area of dorzolamide is not more than 7%.

Foreign insoluble matter <6.11> It meets the requirement.

Insoluble particulate matter <6.08> It meets the requirement.

Sterility <4.06> Perform the test according to the Direct inoculation method, using the culture medium containing 0.7% polysorbate 80 and 0.1% of lecithin: it meets the requirement.

Assay Weigh accurately a portion of Dorzolamide Hydrochloride Ophthalmic Solution, equivalent to about 5 mg of dorzolamide ($C_{10}H_{16}N_2O_4S_3$), add the diluting solution to make exactly 50 mL, and use this solution as the sample solution. Separately, weigh accurately about 20 mg of Dorzolamide Hydrochloride RS (separately determine the water <2.48> in the same manner as Dorzolamide Hydrochloride), dissolve in the diluting solution to make exactly 200 mL, and use this solution as the standard solution. Perform the test with exactly 20 μ L each of the sample solution and standard solution as directed under Liquid Chromatography <2.01> according to the following conditions, and determine the peak areas, A_T and A_S , of dorzolamide in each solution.

Diluting solution: To 2 mL of phosphoric acid add 900 mL of water, adjust to pH 3.0 with triethylamine, then add water to make 1000 mL.

$$\begin{aligned} &\text{Amount (mg/mL) of dorzolamide (C}_{10}\text{H}_{16}\text{N}_2\text{O}_4\text{S}_3) \\ &= M_S/M_T \times A_T/A_S \times 1/4 \times d \times 0.899 \end{aligned}$$

M_S : Amount (mg) of Dorzolamide Hydrochloride RS taken, calculated on the anhydrous basis

M_T : Amount (g) of Dorzolamide Hydrochloride Ophthalmic Solution taken

d : Density (g/mL) of Dorzolamide Hydrochloride Ophthalmic Solution

Operating conditions—

Detector: An ultraviolet absorption photometer (wavelength: 253 nm).

Column: A stainless steel column 4.6 mm in inside diameter and 25 cm in length, packed with octylsilylated silica gel for liquid chromatography (5 μ m in particle diameter).

Column temperature: A constant temperature of about 25°C.

Mobile phase: A mixture of the diluting solution and acetonitrile (19:1).

Flow rate: Adjust so that the retention time of dorzolamide is about 10 minutes.

System suitability—

System performance: When the procedure is run with 20 μ L of the standard solution under the above operating conditions, the number of theoretical plates and the symmetry factor of the peak of dorzolamide are not less than 6000 and not more than 1.8, respectively.

System repeatability: When the test is repeated 6 times with 20 μ L of the standard solution under the above operating conditions, the relative standard deviation of the peak area of dorzolamide is not more than 1.0%.

Containers and storage Containers—Tight containers.

Dorzolamide Hydrochloride and Timolol Maleate Ophthalmic Solution

ドルゾラミド塩酸塩・チモロールマレイン酸塩点眼液

Dorzolamide Hydrochloride and Timolol Maleate Ophthalmic Solution contains not less than 93.0% and not more than 107.0% of the labelled amount of dorzolamide ($C_{10}H_{16}N_2O_4S_3$: 324.44), and not less than 93.0% and not more than 110.0% of the labelled amount of timolol ($C_{13}H_{24}N_4O_3S$: 316.42).

Method of Preparation Prepare as directed under Ophthalmic Liquids and Solutions, with Dorzolamide Hydrochloride

and Timolol Maleate.

Description Dorzolamide Hydrochloride and Timolol Maleate Ophthalmic Solution is a clear, colorless, and slightly viscous liquid.

Identification (1) Perform the test with 20 μ L each of the sample solution and the standard solution obtained in the Assay (1) as directed under Liquid Chromatography <2.01> according to the conditions described in the Assay (1): the retention times of the peak of dorzolamide in the chromatograms obtained from the sample solution and the standard solution are the same.

(2) Perform the test with 20 μ L each of the sample solution and the standard solution obtained in the Assay (2) as directed under Liquid Chromatography <2.01> according to the conditions described in the Assay (2): the retention times of the peak of timolol in the chromatograms obtained from the sample solution and the standard solution are the same.

Osmotic pressure ratio Being specified separately when the drug is granted approval based on the Law.

Viscosity Being specified separately when the drug is granted approval based on the Law.

pH Being specified separately when the drug is granted approval based on the Law.

Purity (1) Related substance 1—Use the sample solution obtained in the Assay (1) as the sample solution. Pipet 1 mL of the sample solution, add a mixture of diluted phosphoric acid (1 in 500) and acetonitrile (19:1) to make exactly 100 mL, and use this solution as the standard solution. Perform the test with exactly 20 μ L each of the sample solution and standard solution as directed under Liquid Chromatography <2.01> according to the following conditions, and determine each peak area by the automatic integration method: the peak area of related substance OA having the relative retention time of about 0.8 to dorzolamide obtained from the sample solution is not larger than 1/5 times the peak area of dorzolamide from the standard solution, and the peak area of related substance OB having the relative retention time of about 1.2 to dorzolamide from the sample solution is not larger than 2.4 times the peak area of dorzolamide from the standard solution. The area of the peak other than dorzolamide and the peaks mentioned above from the sample solution is not larger than 1/5 times the peak area of dorzolamide from the standard solution. Furthermore, the total area of the peaks other than dorzolamide from the sample solution is not larger than 2.5 times the peak area of dorzolamide from the standard solution.

Operating conditions—

Detector, column, column temperature, mobile phase, and flow rate: Proceed as directed in the operating conditions in the Assay (1).

Time span of measurement: For 18 minutes after injection of the sample solution.

System suitability—

System performance: Proceed as directed in the system suitability in the Assay (1).

Test for required detectability: Pipet 2 mL of the standard solution, add a mixture of diluted phosphoric acid (1 in 500 mL) and acetonitrile (19:1) to make exactly 20 mL. Confirm that the peak area of dorzolamide obtained with 20 μ L of this solution is equivalent to 7 to 13% of that with 20 μ L of the standard solution.

System repeatability: When the test is repeated 6 times with 20 μ L of the standard solution under the above operating conditions, the relative standard deviation of the peak

area of dorzolamide is not more than 5.0%.

(2) Related substance 2—Use the sample solution obtained in the Assay (2) as the sample solution. Pipet 2 mL of the sample solution, add the mobile phase to make exactly 200 mL, and use this solution as the standard solution. Perform the test with exactly 20 μ L each of the sample solution and standard solution as directed under Liquid Chromatography <2.01> according to the following conditions, and determine each peak area by the automatic integration method: the area of the peak other than timolol and the peak having the relative retention time of about 0.49 to timolol obtained from the sample solution is not larger than 2/5 times the peak area of timolol from the standard solution. Furthermore, the total area of the peaks other than timolol and the peak having the relative retention time of about 0.49 to timolol, from the sample solution is not larger than 1/2 times the peak area of timolol from the standard solution.

Operating conditions—

Detector, column, column temperature, mobile phase, and flow rate: Proceed as directed in the operating conditions in the Assay (2).

Time span of measurement: For 10 minutes after injection of the sample solution.

System suitability—

System performance and system repeatability: Proceed as directed in the system suitability in the Assay (2).

Test for required detectability: Pipet 10 mL of the standard solution, add the mobile phase to make exactly 100 mL. Confirm that the peak area of timolol obtained with 20 μ L of this solution is equivalent to 7 to 13% of that with 20 μ L of the standard solution.

Foreign insoluble matter <6.11> It meets the requirement.

Insoluble particulate matter <6.08> It meets the requirement.

Sterility <4.06> It meets the requirement.

Assay (1) Dorzolamide hydrochloride—Pipet a volume of Dorzolamide Hydrochloride and Timolol Maleate Ophthalmic Solution, equivalent to about 2.5 mg of dorzolamide ($C_{10}H_{16}N_2O_4S_3$), add a mixture of diluted phosphoric acid (1 in 500) and acetonitrile (19:1) to make exactly 25 mL, and use this solution as the sample solution. Separately, weigh accurately about 22 mg of Dorzolamide Hydrochloride RS (separately determine the water <2.48> in the same manner as Dorzolamide Hydrochloride), dissolve in a mixture of diluted phosphoric acid (1 in 500) and acetonitrile (19:1) to make exactly 200 mL, and use this solution as the standard solution. Perform the test with exactly 20 μ L each of the sample solution and standard solution as directed under Liquid Chromatography <2.01> according to the following conditions, and determine the peak areas, A_T and A_S , of dorzolamide in each solution.

Amount (mg) of dorzolamide ($C_{10}H_{16}N_2O_4S_3$) in 1 mL of Dorzolamide Hydrochloride and Timolol Maleate Ophthalmic Solution

$$= M_S/M_T \times A_T/A_S \times 1/8 \times d \times 0.899$$

M_S : Amount (mg) of Dorzolamide Hydrochloride RS taken, calculated on the anhydrous basis

M_T : Amount (g) of Dorzolamide Hydrochloride and Timolol Maleate Ophthalmic Solution taken

d : Density (g/mL) of Dorzolamide Hydrochloride and Timolol Maleate Ophthalmic Solution

Operating conditions—

Detector: An ultraviolet absorption photometer (wave-

length: 253 nm).

Column: A stainless steel column 4.6 mm in inside diameter and 25 cm in length, packed with octylsilylated silica gel for liquid chromatography (5 μ m in particle diameter).

Column temperature: A constant temperature of about 25°C.

Mobile phase A: A mixture of diluted phosphoric acid (1 in 500) and acetonitrile (19:1).

Mobile phase B: A mixture of acetonitrile and diluted phosphoric acid (1 in 500) (19:1).

Flowing of mobile phase: Control the gradient by mixing the mobile phases A and B as directed in the following table.

Time after injection of sample (min)	Mobile phase A (vol%)	Mobile phase B (vol%)
0 – 15.0	100	0
15.0 – 15.1	100 → 0	0 → 100
15.1 – 20.0	0	100

Flow rate: 1.2 mL per minute.

System suitability—

System performance: When the procedure is run with 20 μ L of the standard solution, the number of theoretical plates and the symmetry factor of the peak of dorzolamide are not less than 5000 and not more than 3.0, respectively.

System repeatability: When the test is repeated 6 times with 20 μ L of the standard solution, the relative standard deviation of the peak area of dorzolamide is not more than 2.0%.

(2) Timolol maleate—Pipet a volume of Dorzolamide Hydrochloride and Timolol Maleate Ophthalmic Solution, equivalent to about 6.5 mg of timolol ($C_{13}H_{24}N_4O_3S$), add the mobile phase to make exactly 25 mL, and use this solution as the sample solution. Separately, weigh accurately about 34 mg of Timolol Maleate RS, previously dried at 100°C under reduced pressure for 3 hours, dissolve in the mobile phase to make exactly 100 mL, and use this solution as the standard solution. Perform the test with exactly 20 μ L each of the sample solution and standard solution as directed under Liquid Chromatography <2.01> according to the following conditions, and determine the peak areas, A_T and A_S , of timolol in each solution.

Amount (mg) of timolol ($C_{13}H_{24}N_4O_3S$) in 1 mL of Dorzolamide Hydrochloride and Timolol Maleate Ophthalmic Solution

$$= M_S/M_T \times A_T/A_S \times 1/4 \times d \times 0.732$$

M_S : Amount (mg) of Timolol Maleate RS taken

M_T : Amount (g) of Dorzolamide Hydrochloride and Timolol Maleate Ophthalmic Solution taken

d : Density (g/mL) of Dorzolamide Hydrochloride and Timolol Maleate Ophthalmic Solution

Operating conditions—

Detector: An ultraviolet absorption photometer (wavelength: 295 nm).

Column: A stainless steel column 4.6 mm in inside diameter and 25 cm in length, packed with octadecylsilylated silica gel for liquid chromatography (5 μ m in particle diameter).

Column temperature: A constant temperature of about 40°C.

Mobile phase: Dissolve 25 g of sodium dihydrogen phosphate dihydrate in water to make 2000 mL, and adjust to pH 2.8 with phosphoric acid. To 600 mL of this solution add 400 mL of methanol.

Flow rate: 1.0 mL per minute.

System suitability—

System performance: Dissolve 44 mg of Timolol Maleate RS in 4 mL of sodium hydroxide solution (1 in 250), warm at 70°C for 15 hours, and add the mobile phase to make 25 mL. To 5 mL of this solution, add 28 mg of Dorzolamide Hydrochloride RS to dissolve, add the mobile phase to make 25 mL, and use this solution as the solution for system suitability test. When the procedure is run with 20 µL of the solution for system suitability test according to the above operating conditions, the number of theoretical plates and the symmetry factor of the peak of timolol are not less than 3000 and not more than 2.0, respectively. The resolution between the co-eluting peak of dorzolamide and maleate, having the relative retention time of about 0.49 to timolol, and the peak, having the relative retention time of about 0.58 to timolol, is not less than 1.5, and the resolution between the peaks having the relative retention times of about 0.58 and about 0.70 to timolol is not less than 1.5.

System repeatability: When the test is repeated 6 times with 20 µL of the solution for system suitability test, the relative standard deviation of the peak area of timolol is not more than 2.0%.

Containers and storage Containers—Tight containers.

Storage—Light-resistant.

Others

Related substance OA:

(4*S*,6*S*)-4-Amino-6-methyl-5,6-dihydro-4*H*-thieno[2,3-*b*]thiopyran-2-sulfonamide 7,7-dioxide

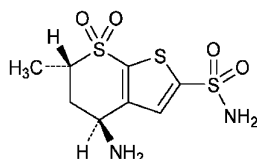

Related substance OB:

(4*RS*,6*SR*)-4-Ethylamino-6-methyl-5,6-dihydro-4*H*-thieno[2,3-*b*]thiopyran-2-sulfonamide 7,7-dioxide

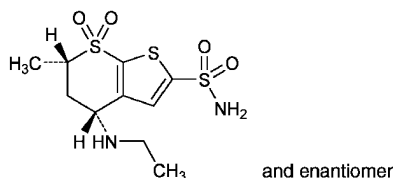
**Doxapram Hydrochloride Hydrate**

ドキサプラム塩酸塩水和物

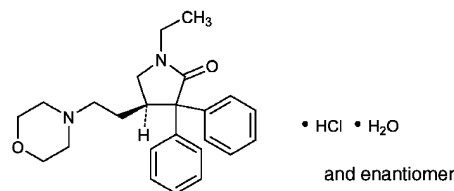

$C_{24}H_{30}N_2O_2 \cdot HCl \cdot H_2O$: 432.98

(4*RS*)-1-Ethyl-4-[2-(morpholin-4-yl)ethyl]-3,3-diphenylpyrrolidin-2-one monohydrochloride monohydrate [7081-53-0]

Doxapram Hydrochloride Hydrate contains not less than 98.0% of doxapram hydrochloride ($C_{24}H_{30}N_2O_2 \cdot HCl$: 414.97), calculated on the anhydrous basis.

Description Doxapram Hydrochloride Hydrate occurs as white, crystals or crystalline powder.

It is freely soluble in methanol and in acetic acid (100), sparingly soluble in water, in ethanol (95) and in acetic anhydride, and practically insoluble in diethyl ether.

Identification (1) Determine the absorption spectrum of a solution of Doxapram Hydrochloride Hydrate (1 in 2500) as directed under Ultraviolet-visible Spectrophotometry <2.24>, and compare the spectrum with the Reference Spectrum: both spectra exhibit similar intensities of absorption at the same wavelengths.

(2) Determine the infrared absorption spectrum of Doxapram Hydrochloride Hydrate as directed in the potassium bromide disk method under Infrared Spectrophotometry <2.25>, and compare the spectrum with the Reference Spectrum: both spectra exhibit similar intensities of absorption at the same wave numbers.

(3) A solution of Doxapram Hydrochloride Hydrate (1 in 50) responds to Qualitative Tests <1.09> for chloride.

pH <2.54> Dissolve 1.0 g of Doxapram Hydrochloride Hydrate in 50 mL of water: the pH of this solution is between 3.5 and 5.0.

Melting point <2.60> 218 – 222°C

Purity (1) Clarity and color of solution—Dissolve 1.0 g of Doxapram Hydrochloride Hydrate in 50 mL of water: the solution is clear and colorless.

(2) Sulfate <1.14>—Perform the test with 1.0 g of Doxapram Hydrochloride Hydrate. Prepare the control solution with 0.50 mL of 0.005 mol/L sulfuric acid VS (not more than 0.024%).

(3) Heavy metals <1.07>—Proceed with 2.0 g of Doxapram Hydrochloride Hydrate according to Method 2, and perform the test. Prepare the control solution with 2.0 mL of Standard Lead Solution (not more than 10 ppm).

(4) Arsenic <1.11>—Prepare the test solution with 1.0 g of Doxapram Hydrochloride Hydrate according to Method 3, and perform the test (not more than 2 ppm).

(5) Related substances—Dissolve 0.5 g of Doxapram Hydrochloride Hydrate in 10 mL of methanol, and use this solution as the sample solution. Pipet 3 mL of the sample solution, and add methanol to make exactly 100 mL. Pipet 5 mL of this solution, add methanol to make exactly 50 mL, and use this solution as the standard solution. Perform the test

with these solutions as directed under Thin-layer Chromatography <2.03>. Spot 6 μL each of the sample solution and standard solution on a plate of silica gel for thin-layer chromatography. Develop the plate with a mixture of chloroform, formic acid, ethyl formate and methanol (8:3:3:2) to a distance of about 10 cm, and air-dry the plate. Allow the plate to stand in iodine vapor: the spots other than the principal spot obtained from the sample solution are not more intense than the spot from the standard solution.

Water <2.48> 3.5 – 4.5% (0.5 g, volumetric titration, direct titration).

Residue on ignition <2.44> Not more than 0.3% (1 g).

Assay Weigh accurately about 0.8 g of Doxapram Hydrochloride Hydrate, dissolve in 50 mL of a mixture of acetic anhydride and acetic acid (100) (7:3), and titrate <2.50> with 0.1 mol/L perchloric acid VS (potentiometric titration). Perform a blank determination in the same manner, and make any necessary correction.

Each mL of 0.1 mol/L perchloric acid VS
= 41.50 mg of $\text{C}_{24}\text{H}_{30}\text{N}_2\text{O}_2 \cdot \text{HCl}$

Containers and storage Containers—Tight containers.

Doxazosin Mesilate

ドキサゾシンメシル酸塩

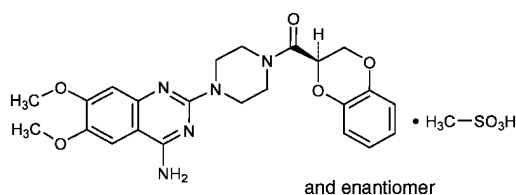

$\text{C}_{23}\text{H}_{25}\text{N}_5\text{O}_5 \cdot \text{CH}_4\text{O}_3\text{S}$: 547.58

1-(4-Amino-6,7-dimethoxyquinazolin-2-yl)-4-[[*(2R)*-2,3-dihydro-1,4-benzodioxin-2-yl]carbonyl]piperazine monomethanesulfonate
[77883-43-3]

Doxazosin Mesilate, when dried, contains not less than 98.0% and not more than 102.0% of doxazosin mesilate ($\text{C}_{23}\text{H}_{25}\text{N}_5\text{O}_5 \cdot \text{CH}_4\text{O}_3\text{S}$).

Description Doxazosin Mesilate occurs as a white to yellowish white crystalline powder.

It is freely soluble in dimethylsulfoxide, slightly soluble in water and in methanol, and very slightly soluble in ethanol (99.5).

A solution of Doxazosin Mesilate in dimethylsulfoxide solution (1 in 20) shows no optical rotation.

Melting point: about 272°C (with decomposition).

Identification (1) Determine the absorption spectrum of a solution of Doxazosin Mesilate in 0.01 mol/L hydrochloric acid-methanol TS (1 in 200,000) as directed under Ultraviolet-visible Spectrophotometry <2.24>, and compare the spectrum with the Reference Spectrum or the spectrum of a solution of Doxazosin Mesilate RS prepared in the same manner as the sample solution: both spectra exhibit similar intensities of absorption at the same wavelengths.

(2) Determine the infrared absorption spectrum of Doxazosin Mesilate as directed in the potassium bromide disk method under Infrared Spectrophotometry <2.25>, and compare the spectrum with the Reference Spectrum or the spec-

trum of Doxazosin Mesilate RS: both spectra exhibit similar intensities of absorption at the same wave numbers.

(3) 30 mg of Doxazosin Mesilate responds to Qualitative Tests <1.09> (2) for mesilate.

Purity (1) Heavy metals <1.07>—Proceed with 1.0 g of Doxazosin Mesilate according to Method 2, and perform the test. Prepare the control solution with 2.0 mL of Standard Lead Solution (not more than 20 ppm).

(2) Related substances—Dissolve 20 mg of Doxazosin Mesilate in 5 mL of a mixture of methanol and acetic acid (100) (1:1), and use this solution as the sample solution. Pipet 1 mL of the sample solution, add a mixture of methanol and acetic acid (100) (1:1) to make exactly 100 mL. Pipet 5 mL of this solution, add a mixture of methanol and acetic acid (100) (1:1) to make exactly 10 mL, and use this solution as the standard solution. Perform the test with these solutions as directed under Thin-layer Chromatography <2.03>. Spot 5 μL each of the sample solution and standard solution on a plate of silica gel with fluorescent indicator for thin-layer chromatography. Develop the plate with an upper layer of a mixture, prepared by adding 1 volume of water and 1 volume of acetic acid (100) to 2 volumes of 4-methyl-2-pentanone and shaking, to a distance of about 10 cm, and air-dry the plate. Examine under ultraviolet light (main wavelength: 254 nm): the spot at the *R_f* value about 0.15 obtained from the sample solution is not more intense than the spot from the standard solution, and no spots other than the principal spot and other than the spots mentioned above appear from the sample solution.

Loss on drying <2.41> Not more than 1.0% (1 g, 105°C, 4 hours).

Residue on ignition <2.44> Not more than 0.2% (1 g).

Assay Weigh accurately about 25 mg each of Doxazosin Mesilate and Doxazosin Mesilate RS, previously dried, dissolve separately in methanol to make exactly 50 mL. Pipet 3 mL each of these solutions, add the mobile phase to make exactly 100 mL, and use these solutions as the sample solution and the standard solution, respectively. Perform the test with exactly 10 μL each of the sample solution and standard solution as directed under Liquid Chromatography <2.01> according to the following conditions, and determine the peak areas, A_T and A_S , of doxazosin in each solution.

Amount (mg) of doxazosin mesilate ($\text{C}_{23}\text{H}_{25}\text{N}_5\text{O}_5 \cdot \text{CH}_4\text{O}_3\text{S}$)
= $M_S \times A_T / A_S$

M_S : Amount (mg) of Doxazosin Mesilate RS taken

Operating conditions—

Detector: An ultraviolet absorption photometer (wavelength: 246 nm).

Column: A stainless steel column 3.9 mm in inside diameter and 15 cm in length, packed with octadecylsilanized silica gel for liquid chromatography (4 μm in particle diameter).

Column temperature: A constant temperature of about 25°C.

Mobile phase: A mixture of 0.05 mol/L potassium dihydrogen phosphate TS (pH 3.0), methanol and acetonitrile (12:8:3).

Flow rate: Adjust so that the retention time of doxazosin is about 5 minutes.

System suitability—

System performance: When the procedure is run with 10 μL of the standard solution under the above operating conditions, the number of theoretical plates and the symmetry factor of the peak of doxazosin are not less than 2000 and

not more than 2.0, respectively.

System repeatability: When the test is repeated 6 times with 10 μL of the standard solution under the above operating conditions, the relative standard deviation of the peak area of doxazosin is not more than 1.0%.

Containers and storage Containers—Tight containers.

Doxazosin Mesilate Tablets

ドキサゾシンメシル酸塩錠

Doxazosin Mesilate Tablets contain not less than 95.0% and not more than 105.0% of the labeled amount of doxazosin ($\text{C}_{23}\text{H}_{25}\text{N}_5\text{O}_5$; 451.48).

Method of preparation Prepare as directed under Tablets, with Doxazosin Mesilate.

Identification To a quantity of powdered Doxazosin Mesilate Tablets, equivalent to 5 mg of doxazosin ($\text{C}_{23}\text{H}_{25}\text{N}_5\text{O}_5$), add 100 mL of 0.01 mol/L hydrochloric acid-methanol TS, shake vigorously, and centrifuge. To 4 mL of the supernatant liquid add 0.01 mol/L hydrochloric acid-methanol TS to make 50 mL, and determine the absorption spectrum of this solution as directed under Ultraviolet-visible Spectrophotometry <2.24>: it exhibits a maximum between 244 nm and 248 nm.

Uniformity of dosage units <6.02> Perform the test according to the following method: it meets the requirement of the Content uniformity test.

To 1 tablet of Doxazosin Mesilate Tablets add 1 mL of water, disintegrate the tablet by shaking, add 0.01 mol/L hydrochloric acid-methanol TS to make exactly 100 mL, and shake for 30 minutes. Centrifuge, pipet V mL of the supernatant liquid, add 0.01 mol/L hydrochloric acid-methanol TS to make exactly V' mL so that each mL contains about 5 μg of doxazosin ($\text{C}_{23}\text{H}_{25}\text{N}_5\text{O}_5$), and use this solution as the sample solution. Separately, weigh accurately about 30 mg of Doxazosin Mesilate RS, previously dried at 105°C for 4 hours, and dissolve in 0.01 mol/L hydrochloric acid-methanol TS to make exactly 100 mL. Pipet 2 mL of this solution, add 0.01 mol/L hydrochloric acid-methanol TS to make exactly 100 mL, and use this solution as the standard solution. Then, proceed as directed in the Assay.

$$\begin{aligned} & \text{Amount (mg) of doxazosin (C}_{23}\text{H}_{25}\text{N}_5\text{O}_5) \\ & = M_S \times A_T/A_S \times V'/V \times 1/50 \times 0.825 \end{aligned}$$

M_S : Amount (mg) of Doxazosin Mesilate RS taken

Dissolution <6.10> When the test is performed at 75 revolutions per minute according to the Paddle method, using 900 mL of 0.05 mol/L acetic acid-sodium acetate buffer solution (pH 4.0) as the dissolution medium, the dissolution rate in 15 minutes of Doxazosin Mesilate Tablets is not less than 75%.

Start the test with 1 tablet of Doxazosin Mesilate Tablets, withdraw not less than 20 mL of the medium at the specified minute after starting the test, and filter through a membrane filter with a pore size not exceeding 0.45 μm . Discard not less than 10 mL of the first filtrate, pipet V mL of the subsequent filtrate, and add the dissolution medium to make exactly V' mL so that each mL contains about 0.56 μg of doxazosin ($\text{C}_{23}\text{H}_{25}\text{N}_5\text{O}_5$). Pipet 5 mL of this solution, add exactly 5 mL of methanol, and use this solution as the sample solution. Separately, weigh accurately about 21 mg of Doxazosin Mesilate RS, previously dried at 105°C for 4 hours, and dissolve in methanol to make exactly 50 mL. Pipet 2 mL of this

solution, add methanol to make exactly 50 mL. Then, pipet 2 mL of this solution, add methanol to make exactly 50 mL. Pipet 5 mL of this solution, add exactly 5 mL of the dissolution medium, and use this solution as the standard solution. Perform the test with exactly 20 μL each of the sample solution and standard solution as directed under Liquid Chromatography <2.01> according to the following conditions, and determine the peak areas, A_T and A_S , of doxazosin in each solution.

Dissolution rate (%) with respect to the labeled amount of doxazosin ($\text{C}_{23}\text{H}_{25}\text{N}_5\text{O}_5$)

$$= M_S \times A_T/A_S \times V'/V \times 1/C \times 72/25 \times 0.825$$

M_S : Amount (mg) of Doxazosin Mesilate RS taken

C : Labeled amount (mg) of doxazosin ($\text{C}_{23}\text{H}_{25}\text{N}_5\text{O}_5$) in 1 tablet

Operating conditions—

Detector: An ultraviolet absorption photometer (wavelength: 246 nm).

Column: A stainless steel column 4.6 mm in inside diameter and 15 cm in length, packed with octadecylsilanized silica gel for liquid chromatography (5 μm in particle diameter).

Column temperature: A constant temperature of about 35°C.

Mobile phase: Dissolve 3.4 g of potassium dihydrogen phosphate in 500 mL of water, and adjust to pH 3.0 with diluted phosphoric acid (1 in 10). To 450 mL of this solution add 550 mL of methanol.

Flow rate: Adjust so that the retention time of doxazosin is about 5 minutes.

System suitability—

System performance: When the procedure is run with 20 μL of the standard solution under the above operating conditions, the number of theoretical plates and the symmetry factor of the peak of doxazosin are not less than 2000 and not more than 2.0, respectively.

System repeatability: When the test is repeated 6 times with 20 μL of the standard solution under the above operating conditions, the relative standard deviation of the peak area of doxazosin is not more than 2.0%.

Assay Weigh accurately the mass of not less than 20 Doxazosin Mesilate Tablets, and powder. Weigh accurately a portion of the powder, equivalent to about 5 mg of doxazosin ($\text{C}_{23}\text{H}_{25}\text{N}_5\text{O}_5$), add 0.01 mol/L hydrochloric acid-methanol TS to make exactly 100 mL, and stir for 30 minutes. Centrifuge, pipet 4 mL of the supernatant liquid, add 0.01 mol/L hydrochloric acid-methanol TS to make exactly 50 mL, and use this solution as the sample solution. Separately, weigh accurately about 24 mg of Doxazosin Mesilate RS, previously dried at 105°C for 4 hours, dissolve in 0.01 mol/L hydrochloric acid-methanol TS to make exactly 100 mL. Pipet 2 mL of this solution, add 0.01 mol/L hydrochloric acid-methanol TS to make exactly 100 mL, and use this solution as the standard solution. Determine the absorbances, A_T and A_S , of the sample solution and standard solution at 246 nm as directed under Ultraviolet-visible Spectrophotometry <2.24>.

$$\begin{aligned} & \text{Amount (mg) of doxazosin (C}_{23}\text{H}_{25}\text{N}_5\text{O}_5) \\ & = M_S \times A_T/A_S \times 1/4 \times 0.825 \end{aligned}$$

M_S : Amount (mg) of Doxazosin Mesilate RS taken

Containers and storage Containers—Well-closed containers.

Doxifluridine

ドキシフルリジン

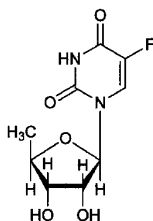

$C_9H_{11}FN_2O_5$; 246.19
5'-Deoxy-5-fluorouridine
[3094-09-5]

Doxifluridine, when dried, contains not less than 98.5% and not more than 101.0% of doxifluridine ($C_9H_{11}FN_2O_5$).

Description Doxifluridine occurs as a white crystalline powder.

It is freely soluble in *N,N*-dimethylformamide, soluble in water and in methanol, and slightly soluble in ethanol (99.5).

It dissolves in 0.1 mol/L hydrochloric acid TS and in 0.01 mol/L sodium hydroxide TS.

Melting point: about 191°C (with decomposition).

Identification (1) Determine the absorption spectrum of a solution of Doxifluridine in 0.1 mol/L hydrochloric acid TS (1 in 50,000) as directed under Ultraviolet-visible Spectrophotometry <2.24>, and compare the spectrum with the Reference Spectrum: both spectra exhibit similar intensities of absorption at the same wavelengths.

(2) Determine the infrared absorption spectrum of Doxifluridine, previously dried, as directed in the potassium bromide disk method under Infrared Spectrophotometry <2.25>, and compare the spectrum with the Reference Spectrum: both spectra exhibit similar intensities of absorption at the same wave numbers.

Optical rotation <2.49> $[\alpha]_{365}^{20}$: +160 – +174° (after drying, 0.1 g, water, 10 mL, 100 mm).

pH <2.54> The pH of a solution obtained by dissolving 0.10 g of Doxifluridine in 10 mL of water is between 4.2 and 5.2.

Purity (1) Fluoride—Dissolve 0.10 g of Doxifluridine in 10.0 mL of diluted 0.01 mol/L sodium hydroxide TS (1 in 20). Transfer 5.0 mL of this solution into a 20-mL volumetric flask, add 5 mL of a mixture of acetone and lanthanum-alizarin complexone TS (2:1) and water to make 20 mL, allow to stand for 1 hour, and use this solution as the sample solution. Separately, put 1.0 mL of Standard Fluorine Solution in a 20-mL volumetric flask, add 5.0 mL of diluted 0.01 mol/L sodium hydroxide TS (1 in 20) and 5 mL of the mixture of acetone and alizarin complexone TS (2:1), then proceed in the same manner as for preparation of the sample solution, and use the solution so obtained as the standard solution. Determine the absorbances, A_T and A_S , of the sample solution and standard solution at 620 nm as directed under Ultraviolet-visible Spectrophotometry <2.24>, using a solution obtained in the same way with 5.0 mL of diluted 0.01 mol/L sodium hydroxide TS (1 in 20) as a blank: A_T is not larger than A_S .

(2) Chloride <1.03>—Perform the test with 0.30 g of Doxifluridine. Prepare the control solution with 0.30 mL of

0.01 mol/L hydrochloric acid VS (not more than 0.035%).

(3) Heavy metals <1.07>—Proceed with 1.0 g of Doxifluridine according to Method 1, and perform the test. Prepare the control solution with 2.0 mL of Standard Lead Solution (not more than 20 ppm).

(4) Related substances—Dissolve 20 mg of Doxifluridine in 2 mL of methanol, and use this solution as the sample solution. Pipet 1 mL of the sample solution, and add methanol to make exactly 25 mL. Pipet 5 mL of this solution, add methanol to make exactly 50 mL, and use this solution as the standard solution. Perform the test with these solutions as directed under Thin-layer Chromatography <2.03>. Spot 10 μ L each of the sample solution and standard solution on a plate of silica gel with fluorescent indicator for thin-layer chromatography. Develop the plate with a mixture of ethyl acetate, acetic acid (100) and water (17:2:1) to a distance of about 12 cm, and air-dry the plate. Examine under ultraviolet light (main wavelength: 254 nm); the number of the spot other than the principal spot obtained from the sample solution is not more than three, and they are not more intense than the spot from the standard solution.

Loss on drying <2.41> Not more than 0.5% (1 g, 105°C, 4 hours).

Residue on ignition <2.44> Not more than 0.1% (1 g, platinum crucible).

Assay Weigh accurately about 0.25 g of Doxifluridine, previously dried, dissolve in 50 mL of *N,N*-dimethylformamide, and titrate <2.50> with 0.1 mol/L tetramethylammonium hydroxide VS (potentiometric titration). Perform a blank determination in the same manner, and make any necessary correction.

Each mL of 0.1 mol/L tetramethylammonium hydroxide VS = 24.62 mg of $C_9H_{11}FN_2O_5$

Containers and storage Containers—Tight containers.

Doxifluridine Capsules

ドキシフルリジンカプセル

Doxifluridine Capsules contain not less than 95.0% and not more than 105.0% of the labeled amount of doxifluridine ($C_9H_{11}FN_2O_5$; 246.19).

Method of preparation Prepare as directed under Capsules, with Doxifluridine.

Identification (1) Dissolve an amount of the contents of Doxifluridine Capsules, equivalent to 20 mg of Doxifluridine, in 0.1 mol/L hydrochloric acid TS to make 100 mL, and filter. To 1 mL of the filtrate add 0.1 mol/L hydrochloric acid TS to make 20 mL, and determine the absorption spectrum of this solution as directed under Ultraviolet-visible Spectrophotometry <2.24>, using 0.1 mol/L hydrochloric acid TS as the blank: it exhibits a maximum between 267 nm and 271 nm.

(2) To an amount of powdered contents of Doxifluridine Capsules, equivalent to 20 mg of Doxifluridine, add 2 mL of methanol, shake, centrifuge, and use the supernatant liquid as the sample solution. Separately, dissolve 20 mg of doxifluridine in 2 mL of methanol, and use this solution as the standard solution. Perform the test with these solutions as directed under Thin-layer Chromatography <2.03>. Spot 10 μ L each of the sample solution and standard solution on a plate of silica gel with fluorescent indicator for thin-layer

chromatography. Develop the plate with a mixture of ethyl acetate, acetic acid (100) and water (17:2:1) to a distance of about 12 cm, and air-dry the plate. Examine under ultraviolet light (main wavelength: 254 nm): the principal spot obtained from the sample solution and the spot from the standard solution show a dark purple color and these R_f values are the same.

Uniformity of dosage units <6.02> It meets the requirement of the Mass variation test.

Dissolution <6.10> When the test is performed at 50 revolutions per minute according to the Paddle method using the sinker, using 900 mL of water as the dissolution medium, the dissolution rate in 30 minutes of Doxifluridine Capsules is not less than 85%.

Start the test with 1 capsule of Doxifluridine Capsules, withdraw not less than 20 mL of the medium at the specified minute after starting the test, and filter through a membrane filter with a pore size not exceeding $0.45\ \mu\text{m}$. Discard not less than 10 mL of the first filtrate, pipet V mL of the subsequent filtrate, add water to make exactly V' mL so that each mL contains about $13\ \mu\text{g}$ of doxifluridine ($\text{C}_9\text{H}_{11}\text{FN}_2\text{O}_5$), and use this solution as the sample solution. Separately, weigh accurately about 26 mg of doxifluridine for assay, previously dried at 105°C for 4 hours, and dissolve in water to make exactly 100 mL. Pipet 5 mL of this solution, add water to make exactly 100 mL, and use this solution as the standard solution. Determine the absorbances, A_T and A_S , of the sample solution and standard solution at 269 nm as directed under Ultraviolet-visible Spectrophotometry <2.24>.

Dissolution rate (%) with respect to the labeled amount of doxifluridine ($\text{C}_9\text{H}_{11}\text{FN}_2\text{O}_5$)

$$= M_S \times A_T / A_S \times V' / V \times 1 / C \times 45$$

M_S : Amount (mg) of doxifluridine for assay taken

C : Labeled amount (mg) of doxifluridine ($\text{C}_9\text{H}_{11}\text{FN}_2\text{O}_5$) in 1 capsule

Assay Weigh accurately the mass and powder the contents of not less than 20 Doxifluridine Capsules. Weigh accurately a portion of the powder, equivalent to about 50 mg of doxifluridine ($\text{C}_9\text{H}_{11}\text{FN}_2\text{O}_5$), add 40 mL of water, shake for 10 minutes, add water to make exactly 50 mL, and filter. Discard the first 10 mL of the filtrate, pipet 5 mL of the subsequent filtrate, add exactly 10 mL of the internal standard solution, then add a mixture of water and methanol (5:3) to make 100 mL, and use this solution as the sample solution. Separately, weigh accurately about 50 mg of doxifluridine for assay, previously dried at 105°C for 4 hours, and dissolve in water to make exactly 50 mL. Pipet 5 mL of this solution, add exactly 10 mL of the internal standard solution, then add the mixture of water and methanol (5:3) to make exactly 100 mL, and use this solution as the standard solution. Perform the test with $10\ \mu\text{L}$ each of the sample solution and standard solution as directed under Liquid Chromatography <2.01> according to the following conditions, and calculate the ratios, Q_T and Q_S , of the peak height of doxifluridine to that of the internal standard.

$$\begin{aligned} &\text{Amount (mg) of doxifluridine (C}_9\text{H}_{11}\text{FN}_2\text{O}_5) \\ &= M_S \times Q_T / Q_S \end{aligned}$$

M_S : Amount (mg) of doxifluridine for assay taken

Internal standard solution—A solution of anhydrous caffeine (1 in 1000).

Operating conditions—

Detector: An ultraviolet absorption photometer (wavelength: 254 nm).

Column: A stainless steel column 6 mm in inside diameter and 15 cm in length, packed with octadecylsilanized silica gel for liquid chromatography ($5\ \mu\text{m}$ in particle diameter).

Column temperature: A constant temperature of about 25°C .

Mobile phase: A mixture of water and methanol (13:7).

Flow rate: Adjust so that the retention time of doxifluridine is about 2.5 minutes.

System suitability—

System performance: When the procedure is run with $10\ \mu\text{L}$ of the standard solution under the above operating conditions, doxifluridine and the internal standard are eluted in this order with the resolution between these peaks being not less than 5.

System repeatability: When the test is repeated 6 times with $10\ \mu\text{L}$ of the standard solution under the above operating conditions, the relative standard deviation of the ratio of the peak height of doxifluridine to that of the internal standard is not more than 1.0%.

Containers and storage Containers—Tight containers.

Doxorubicin Hydrochloride

ドキシソルビシン塩酸塩

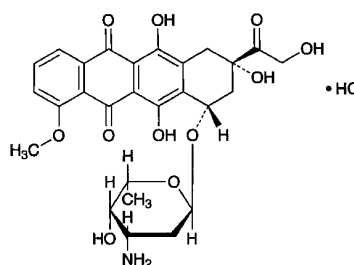

$\text{C}_{27}\text{H}_{29}\text{NO}_{11} \cdot \text{HCl}$: 579.98

(2*S*,4*S*)-4-(3-Amino-2,3,6-trideoxy- α -L-lyxohexopyranosyloxy)-2,5,12-trihydroxy-2-hydroxyacetyl-7-methoxy-1,2,3,4-tetrahydrotetracene-6,11-dione monohydrochloride
[25316-40-9]

Doxorubicin Hydrochloride is the hydrochloride of a derivative of daunorubicin.

It contains not less than $980\ \mu\text{g}$ (potency) and not more than $1080\ \mu\text{g}$ (potency) per mg, calculated on the anhydrous basis. The potency of Doxorubicin Hydrochloride is expressed as mass (potency) of doxorubicin hydrochloride ($\text{C}_{27}\text{H}_{29}\text{NO}_{11} \cdot \text{HCl}$).

Description Doxorubicin Hydrochloride occurs as a red-orange crystalline powder.

It is sparingly soluble in water, slightly soluble in methanol, very slightly soluble in ethanol (99.5), and practically insoluble in acetonitrile.

Identification (1) Determine the absorption spectrum of a solution of Doxorubicin Hydrochloride in methanol (1 in 100,000) as directed under Ultraviolet-visible Spectrophotometry <2.24>, and compare the spectrum with the Reference Spectrum or the spectrum of a solution of Doxorubicin Hydrochloride RS prepared in the same manner as the sample solution: both spectra exhibit similar intensities of absorption at the same wavelengths.

(2) Determine the infrared absorption spectrum of Doxorubicin Hydrochloride as directed in the potassium chloride disk method under Infrared Spectrophotometry

<2.25>, and compare the spectrum with the Reference Spectrum or the spectrum of Doxorubicin Hydrochloride RS: both spectra exhibit similar intensities of absorption at the same wave numbers.

(3) A solution of Doxorubicin Hydrochloride (1 in 200) responds to Qualitative Tests <1.09> (1) for chloride.

Optical rotation <2.49> $[\alpha]_D^{20}$: +240 – +290° (20 mg calculated on the anhydrous basis, methanol, 20 mL, 100 mm).

pH <2.54> The pH of a solution obtained by dissolving 50 mg of Doxorubicin Hydrochloride in 10 mL of water is between 4.0 and 5.5.

Purity (1) Clarity and color of solution—Dissolve 50 mg of Doxorubicin Hydrochloride in 10 mL of water: the solution is clear and red.

(2) Related substances—Dissolve 25 mg of Doxorubicin Hydrochloride in 100 mL of the mobile phase, and use this solution as the sample solution. Pipet 2 mL of the sample solution, add the mobile phase to make exactly 100 mL, and use this solution as the standard solution. Perform the test with exactly 20 μ L each of the sample solution and standard solution as directed under Liquid Chromatography <2.01> according to the following conditions, and determine each peak area by the automatic integration method: the area of the peak other than doxorubicin obtained from the sample solution is not larger than 1/4 times the peak area of doxorubicin from the standard solution, and the total area of the peaks other than doxorubicin from the sample solution is not larger than the peak area of doxorubicin from the standard solution.

Operating conditions—

Detector, column, column temperature, mobile phase, and flow rate: Proceed as directed in the operating conditions in the Assay.

Time span of measurement: About 3 times as long as the retention time of doxorubicin.

System suitability—

Test for required detectability: Pipet 1 mL of the standard solution, and add the mobile phase to make exactly 20 mL. Confirm that the peak area of doxorubicin obtained with 20 μ L of this solution is equivalent to 3.5 to 6.5% of that with 20 μ L of the standard solution.

System performance: Dissolve 5 mg of Doxorubicin Hydrochloride in 20 mL of water, add 1.5 mL of phosphoric acid, and allow to stand at room temperature for 30 minutes. Adjust the pH of this solution to 2.5 with 2 mol/L sodium hydroxide TS. When the procedure is run with 20 μ L of this solution under the above operating conditions, doxorubicinone, having the relative retention time of about 0.6 to doxorubicin, and doxorubicin are eluted in this order with the resolution between these peaks being not less than 5.

System repeatability: When the test is repeated 6 times with 20 μ L of the standard solution under the above operating conditions, the relative standard deviation of the peak area of doxorubicin is not more than 2.0%.

Water <2.48> Not more than 3.0% (0.3 g, volumetric titration, direct titration).

Assay Weigh accurately amounts of Doxorubicin Hydrochloride and Doxorubicin Hydrochloride RS, equivalent to about 10 mg (potency), add exactly 5 mL of the internal standard solution to each, dissolve each in the mobile phase to make 100 mL, and use these solutions as the sample solution and the standard solution, respectively. Perform the test with 10 μ L each of the sample solution and standard solution as directed under Liquid Chromatography <2.01> according

to the following conditions, and calculate the ratios, Q_T and Q_S , of the peak area of doxorubicin to that of the internal standard.

$$\begin{aligned} &\text{Amount } [\mu\text{g (potency)}] \text{ of doxorubicin hydrochloride} \\ &(\text{C}_{27}\text{H}_{29}\text{NO}_{11}\cdot\text{HCl}) \\ &= M_S \times Q_T / Q_S \times 1000 \end{aligned}$$

M_S : Amount [mg (potency)] of Doxorubicin Hydrochloride RS taken

Internal standard solution—A solution of butyl parahydroxybenzoate in the mobile phase (1 in 1000).

Operating conditions—

Detector: An ultraviolet absorption photometer (wavelength: 254 nm).

Column: A stainless steel column 4.6 mm in inside diameter and 25 cm in length, packed with octadecylsilanized silica gel for liquid chromatography (5 μ m in particle diameter).

Column temperature: A constant temperature of about 25°C.

Mobile phase: Dissolve 3 g of sodium lauryl sulfate in 1000 mL of diluted phosphoric acid (7 in 5000), and add 1000 mL of acetonitrile.

Flow rate: Adjust so that the retention time of doxorubicin is about 8 minutes.

System suitability—

System performance: When the procedure is run with 10 μ L of the standard solution under the above operating conditions, doxorubicin and the internal standard are eluted in this order with the resolution between these peaks being not less than 5, and the symmetry factor of the peak of doxorubicin is 0.8 to 1.2.

System repeatability: When the test is repeated 6 times with 10 μ L of the standard solution under the above operating conditions, the relative standard deviation of the ratio of the peak area of doxorubicin to that of the internal standard is not more than 1.0%.

Containers and storage Containers—Tight containers.

Doxorubicin Hydrochloride for Injection

注射用ドキソルビシン塩酸塩

Doxorubicin Hydrochloride for Injection is a preparation for injection, which is dissolved before use.

It contains not less than 90.0% and not more than 110.0% of the labeled potency of doxorubicin hydrochloride ($\text{C}_{27}\text{H}_{29}\text{NO}_{11}\cdot\text{HCl}$; 579.98).

Method of preparation Prepare as directed under Injections, with Doxorubicin Hydrochloride.

Description Doxorubicin Hydrochloride for Injection occurs as a red-orange, powder or masses.

Identification Dissolve an amount of Doxorubicin Hydrochloride for Injection, equivalent to 10 mg (potency) of Doxorubicin Hydrochloride, in methanol to make 100 mL. To 5 mL of this solution add methanol to make 50 mL, and determine the absorption spectrum of the solution as directed under Ultraviolet-visible Spectrophotometry <2.24>: it exhibits maxima between 231 nm and 235 nm, between 250 nm and 254 nm, between 477 nm and 481 nm, and between 493 nm and 497 nm, and exhibits a shoulder between 528 nm and 538 nm.

pH <2.54> The pH of a solution, prepared by dissolving an amount of Doxorubicin Hydrochloride for Injection equivalent to 10 mg (potency) of Doxorubicin Hydrochloride, in 2 mL of water, is 5.0 to 6.0.

Purity Clarity and color of solution—Dissolve an amount of Doxorubicin Hydrochloride for Injection, equivalent to 50 mg (potency) of Doxorubicin Hydrochloride, in 10 mL of water: the solution is clear and red.

Water <2.48> Not more than 4.0% (0.25 g, volumetric titration, direct titration).

Bacterial endotoxins <4.01> Less than 2.50 EU/mg (potency).

Uniformity of dosage units <6.02> It meets the requirement of the Mass variation test.

Foreign insoluble matter <6.06> Perform the test according to Method 2: it meets the requirement.

Insoluble particulate matter <6.07> It meets the requirement.

Sterility <4.06> Perform the test according to the Membrane filtration method: it meets the requirement.

Assay Weigh accurately the mass of the contents of not less than 10 containers of Doxorubicin Hydrochloride for Injection. Weigh accurately an amount of the contents, equivalent to about 10 mg (potency) of Doxorubicin Hydrochloride, add exactly 5 mL of the internal standard solution and the mobile phase to make 100 mL, and use the solution as the sample solution. Separately, weigh accurately an amount of Doxorubicin Hydrochloride RS, equivalent to 10 mg (potency), add exactly 5 mL of the internal standard solution and the mobile phase to make 100 mL, and use this solution as the standard solution. Perform the test with 10 μ L each of the sample solution and standard solution as directed under Liquid Chromatography <2.01>, and calculate the ratios, Q_T and Q_S , of the peak area of doxorubicin to that of the internal standard.

$$\begin{aligned} & \text{Amount [mg (potency)] of doxorubicin hydrochloride} \\ & (\text{C}_{27}\text{H}_{29}\text{NO}_{11}\cdot\text{HCl}) \\ & = M_S \times Q_T/Q_S \end{aligned}$$

M_S : Amount [mg (potency)] of Doxorubicin Hydrochloride RS taken

Internal standard solution—A solution of butyl parahydroxybenzoate in the mobile phase (1 in 1000).

Operating conditions—

Detector: An ultraviolet absorption photometer (wavelength: 254 nm).

Column: A stainless steel column 4.6 mm in inside diameter and 25 cm in length, packed with octadecylsilanized silica gel for liquid chromatography (5 μ m in particle diameter).

Column temperature: A constant temperature of about 25°C.

Mobile phase: Dissolve 3 g of sodium lauryl sulfate in 1000 mL of diluted phosphoric acid (7 in 5000). To this solution add 1000 mL of acetonitrile.

Flow rate: Adjust so that the retention time of doxorubicin is about 8 minutes.

System suitability—

System performance: When the procedure is run with 10 μ L of the standard solution under the above operating conditions, doxorubicin and the internal standard are eluted in this order with the resolution between these peaks being not less than 5, and the symmetry factor of the peak of doxorubicin is between 0.8 and 1.2.

bicin is between 0.8 and 1.2.

System repeatability: When the test is repeated 6 times with 10 μ L of the standard solution under the above operating conditions, the relative standard deviation of the ratio of the peak area of doxorubicin to that of the internal standard is not more than 1.0%.

Containers and storage Containers—Hermetic containers.

Doxycycline Hydrochloride Hydrate

ドキシサイクリン塩酸塩水和物

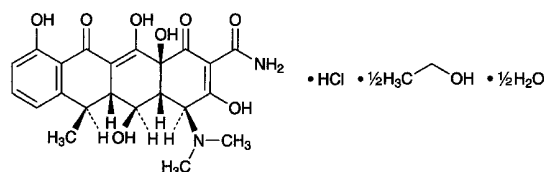

$\text{C}_{22}\text{H}_{24}\text{N}_2\text{O}_8\cdot\text{HCl}\cdot\frac{1}{2}\text{C}_2\text{H}_6\text{O}\cdot\frac{1}{2}\text{H}_2\text{O}$: 512.94
(4*S*,4*aR*,5*S*,5*aR*,6*R*,12*aS*)-4-Dimethylamino-3,5,10,12,12*a*-pentahydroxy-6-methyl-1,11-dioxo-1,4,4*a*,5,5*a*,6,11,12*a*-octahydrotetracene-2-carboxamide monohydrochloride hemiethanolate hemihydrate
[564-25-0, Doxycycline]

Doxycycline Hydrochloride Hydrate is the hydrochloride of a derivative of oxytetracycline.

It contains not less than 880 μ g (potency) and not more than 943 μ g (potency) per mg, calculated on the anhydrous and residual ethanol-free basis. The potency of Doxycycline Hydrochloride Hydrate is expressed as mass (potency) of doxycycline ($\text{C}_{22}\text{H}_{24}\text{N}_2\text{O}_8$: 444.43).

Description Doxycycline Hydrochloride Hydrate occurs as yellow to dark yellow, crystals or crystalline powder.

It is freely soluble in water and in methanol, and slightly soluble in ethanol (99.5).

Identification (1) Determine the absorption spectrum of a solution of Doxycycline Hydrochloride Hydrate in 0.01 mol/L hydrochloric acid-methanol TS (1 in 74,000) as directed under Ultraviolet-visible Spectrophotometry <2.24>, and compare the spectrum with the Reference Spectrum or the spectrum of a solution of Doxycycline Hydrochloride RS prepared in the same manner as the sample solution: both spectra exhibit similar intensities of absorption at the same wavelengths.

(2) Determine the infrared absorption Spectrum of Doxycycline Hydrochloride Hydrate as directed in the potassium bromide disk method under Infrared Spectrophotometry <2.25>, and compare the spectrum with the Reference Spectrum or the spectrum of Doxycycline Hydrochloride RS: both spectra exhibit similar intensities of absorption at the same wave numbers.

(3) Dissolve 10 mg of Doxycycline Hydrochloride Hydrate in 10 mL of water, and add silver nitrate TS: a white turbidity is produced.

Absorbance <2.24> $E_{1\text{cm}}^{1\%}$ (349 nm): 285 – 315 (10 mg, 0.01 mol/L hydrochloric acid-methanol TS, 500 mL).

Optical rotation <2.49> $[\alpha]_D^{20}$: –105 – –120° (0.25 g calculated on the anhydrous and residual ethanol-free basis, 0.01 mol/L hydrochloric acid-methanol TS, 25 mL, 100 mm).

Determine within 5 minutes after the sample solution is prepared.

Purity (1) Heavy metals <1.07>—Proceed with 1.0 g of Doxycycline Hydrochloride Hydrate according to Method 2, and perform the test. Prepare the control solution with 5.0 mL of Standard Lead Solution (not more than 50 ppm).

(2) Related substance—Dissolve 20 mg of Doxycycline Hydrochloride Hydrate in 0.01 mol/L hydrochloric acid TS to make exactly 25 mL, and use this solution as the sample solution. Separately, dissolve 20 mg of 6-epidoxycycline hydrochloride in 0.01 mol/L hydrochloric acid TS to make exactly 25 mL, and use this solution as the 6-epidoxycycline hydrochloride stock solution. Separately, dissolve 20 mg of metacycline hydrochloride in 0.01 mol/L hydrochloric acid TS to make exactly 25 mL, and use this solution as the metacycline hydrochloride stock solution. Pipet 2 mL each of the 6-epidoxycycline hydrochloride stock solution and the metacycline hydrochloride stock solution, add 0.01 mol/L hydrochloric acid TS to make exactly 100 mL, and use this solution as the standard solution. Perform the test with exactly 20 μ L each of the sample solution and standard solution as directed under Liquid Chromatography <2.01> according to the following conditions, and determine each peak area by the automatic integration method: the peak areas of metacycline and 6-epidoxycycline obtained from the sample solution are not larger than the peak areas of them from the standard solution, respectively, and the areas of the two peaks, appeared between the solvent peak and metacycline and behind of doxycycline, from the sample solution are not larger than 1/4 times the peak area of 6-epidoxycycline from the standard solution, and the total area of the peaks other than doxycycline from the sample solution is not larger than 1.5 times the peak area of 6-epidoxycycline from the standard solution.

Operating conditions—

Detector: An ultraviolet absorption photometer (wavelength: 254 nm).

Column: A stainless steel column 4.6 mm in inside diameter and 25 cm in length, packed with styrene-divinylbenzene copolymer for liquid chromatography (8 μ m in particle diameter).

Column temperature: A constant temperature of about 60°C.

Mobile phase: To 125 mL of 0.2 mol/L potassium dihydrogen phosphate TS and 117 mL of 0.2 mol/L sodium hydroxide TS add water to make 500 mL. To 400 mL of this solution add 50 mL of a solution of tetrabutylammonium hydrogensulfate (1 in 100), 10 mL of a solution of disodium dihydrogen ethylenediamine tetraacetate dihydrate (1 in 25), 60 g of *t*-butyl alcohol and 200 mL of water, adjust to pH 8.0 with 2 mol/L sodium hydroxide TS, and add water to make 1000 mL.

Flow rate: Adjust so that the retention time of doxycycline is about 19 minutes.

Time span of measurement: About 2.4 times as long as the retention time of doxycycline, beginning after the solvent peak.

System suitability—

Test for required detectability: Pipet 1 mL of the standard solution, and add 0.01 mol/L hydrochloric acid TS to make exactly 20 mL. Confirm that the peak areas of 6-epidoxycycline and metacycline obtained with 20 μ L of this solution are equivalent to 3.5 to 6.5% of them with 20 μ L of the standard solution, respectively.

System performance: To 8 mL of the sample solution, 3 mL of the 6-epidoxycycline hydrochloride stock solution and

2 mL of the metacycline hydrochloride stock solution add 0.01 mol/L hydrochloric acid TS to make 50 mL. When the procedure is run with 20 μ L of this solution under the above operating conditions, metacycline, 6-epidoxycycline and doxycycline are eluted in this order with the resolutions between the peaks, metacycline and 6-epidoxycycline, and 6-epidoxycycline and doxycycline, being not less than 1.3 and not less than 2.0, respectively, and the symmetry factor of the peak of doxycycline is not more than 1.3.

System repeatability: When the test is repeated 6 times with 20 μ L of the standard solution under the above operating conditions, the relative standard deviations of the peak areas of metacycline and 6-epidoxycycline are not more than 3.0% and not more than 2.0%, respectively.

Ethanol Weigh accurately about 0.1 g of Doxycycline Hydrochloride Hydrate, dissolve in the internal standard solution to make exactly 10 mL, and use this solution as the sample solution. Separately, weigh accurately about 0.4 g of ethanol (99.5), and add the internal standard solution to make exactly 100 mL. Pipet 1 mL of this solution, add the internal standard solution to make exactly 10 mL, and use this solution as the standard solution. Perform the test with 1 μ L each of the sample solution and standard solution as directed under Gas Chromatography <2.02> according to the following conditions, and calculate the ratios, Q_T and Q_S , of the peak area of ethanol to that of the internal standard: the amount of ethanol is not less than 4.3% and not more than 6.0%.

$$\text{Amount (\%)} \text{ of ethanol} = M_S/M_T \times Q_T/Q_S$$

M_S : Amount (mg) of ethanol (99.5) taken

M_T : Amount (mg) of Doxycycline Hydrochloride Hydrate taken

Internal standard solution—A solution of 1-propanol (1 in 2000).

Operating conditions—

Detector: A hydrogen flame-ionization detector.

Column: A glass column 3.2 mm in inside diameter and 1.5 m in length, packed with porous ethylvinylbenzene-divinylbenzene copolymer for gas chromatography (0.0075 μ m in average pore size, 500 – 600 m²/g in specific surface area) (150 – 180 μ m in particle diameter).

Column temperature: A constant temperature of about 135°C.

Carrier gas: Nitrogen.

Flow rate: Adjust so that the retention time of ethanol is about 5 minutes.

System suitability—

System performance: When the procedure is run with 1 μ L of the standard solution under the above operating conditions, ethanol and the internal standard are eluted in this order with the resolution between these peaks being not less than 2.0.

System repeatability: When the test is repeated 5 times with 1 μ L of the standard solution under the above operating conditions, the relative standard deviation of the ratios of the peak area of ethanol to that of the internal standard is not more than 2.0%.

Water <2.48> Not less than 1.4% and not more than 2.8% (0.6 g, volumetric titration, direct titration).

Residue on ignition <2.44> Not more than 0.3% (1 g).

Assay Weigh accurately an amount of Doxycycline Hydrochloride Hydrate and Doxycycline Hydrochloride RS, equivalent to about 50 mg (potency), dissolve each in water

to make exactly 50 mL, and use these solutions as the sample solution and standard solution. Perform the test with exactly 10 μ L each of the sample solution and standard solution as directed under Liquid Chromatography <2.01> according to the following conditions, and determine the peak areas, A_T and A_S , of doxycycline in each solution.

$$\begin{aligned} &\text{Amount } [\mu\text{g (potency)}] \text{ of doxycycline } (\text{C}_{22}\text{H}_{24}\text{N}_2\text{O}_8) \\ &= M_S \times A_T/A_S \times 1000 \end{aligned}$$

M_S : Amount [mg (potency)] of Doxycycline Hydrochloride RS taken

Operating conditions—

Detector: An ultraviolet absorption photometer (wavelength: 280 nm).

Column: A stainless steel column 3.9 mm in inside diameter and 30 cm in length, packed with octadecylsilanized silica gel for liquid chromatography (10 μ m in particle diameter).

Column temperature: A constant temperature of about 30°C.

Mobile phase: Dissolve 7.0 g of sodium dihydrogen phosphate dihydrate in 450 mL of water, add 553 mL of a mixture of methanol and *N,N*-dimethyl-*n*-octylamine (550:3), and adjust the pH to 8.0 with a solution of sodium hydroxide (43 in 200).

Flow rate: Adjust so that the retention time of doxycycline is about 6 minutes.

System suitability—

System performance: When the procedure is run with 10 μ L of the standard solution under the above operating conditions, the theoretical plates and the symmetry factor of the peak of doxycycline are not less than 1000 and not more than 2.0, respectively.

System repeatability: When the test is repeated 6 times with 10 μ L of the standard solution under the above operating conditions, the relative standard deviation of the peak area of doxycycline is not more than 1.0%.

Containers and storage Containers—Tight containers.

Storage—Light-resistant.

Doxycycline Hydrochloride Tablets

ドキシサイクリン塩酸塩錠

Doxycycline Hydrochloride Tablets contain not less than 93.0% and not more than 107.0% of the labeled potency of doxycycline ($\text{C}_{22}\text{H}_{24}\text{N}_2\text{O}_8$: 444.43).

Method of preparation Prepare as directed under Tablets, with Doxycycline Hydrochloride Hydrate.

Identification Weigh a portion of powdered Doxycycline Hydrochloride Tablets, equivalent to 1 mg (potency) of Doxycycline Hydrochloride Hydrate, add 100 mL of 0.01 mol/L hydrochloric acid-methanol TS, shake thoroughly, and filter. Determine the absorption spectrum of this filtrate as directed under Ultraviolet-visible Spectrophotometry <2.24>: it exhibits maxima between 266 nm and 271 nm and between 347 nm and 353 nm.

Purity 4-Epidoxycycline—Use the sample solution obtained in the Assay as the sample solution. Pipet 2 mL of the sample solution, add 0.01 mol/L hydrochloric acid TS to make exactly 200 mL, and use this solution as the standard solution. Perform the test with exactly 10 μ L each of the sample solution and standard solution as directed under Liquid Chromatography <2.01> according to the following con-

ditions, and determine each peak area by the automatic integration method: the area of the peak, having a relative retention time of about 0.6 to doxycycline, obtained from the sample solution is not larger than 1.5 times the peak area of doxycycline from the standard solution.

Operating conditions—

Proceed as directed in the operating conditions in the Assay.

System suitability—

Test for required detectability: To exactly 2 mL of the standard solution add 0.01 mol/L hydrochloric acid TS to make exactly 20 mL. Confirm that the peak area of doxycycline obtained with 10 μ L of this solution is equivalent to 7 to 13% of the peak area of doxycycline with 10 μ L of the standard solution.

System performance: When the procedure is run with 10 μ L of the standard solution under the above operating conditions, the number of theoretical plates and symmetry factor of the peak of doxycycline are not less than 2200 and not more than 1.6, respectively.

System repeatability: When the test is repeated 6 times with 10 μ L of the standard solution under the above operating conditions, the relative standard deviations of the peak area of doxycycline is not more than 2.0%.

Uniformity of dosage units <6.02> Perform the Mass variation test, or the Content uniformity test according to the following method: it meets the requirement.

To 1 tablet of Doxycycline Hydrochloride Tablets add 0.01 mol/L hydrochloric acid TS, disperse the tablet by sonicating, shake for 15 minutes, then add 0.01 mol/L hydrochloric acid TS to make exactly V mL so that each mL contains about 1 mg (potency) of Doxycycline Hydrochloride Hydrate. Centrifuge this solution, filter the supernatant liquid through a membrane filter with a pore size not exceeding 0.45 μ m, discard the first 10 mL of the filtrate, and use the subsequent filtrate as the sample solution. Then, proceed as directed in the Assay.

$$\begin{aligned} &\text{Amount [mg (potency)] of doxycycline } (\text{C}_{22}\text{H}_{24}\text{N}_2\text{O}_8) \\ &= M_S \times A_T/A_S \times V/20 \end{aligned}$$

M_S : Amount [mg (potency)] of Doxycycline Hydrochloride RS taken

Dissolution <6.10> When the test is performed at 50 revolutions per minute according to the Paddle method, using 900 mL of water as the dissolution medium, the dissolution rate in 30 minutes of Doxycycline Hydrochloride Tablets is not less than 85%.

Start the test with 1 tablet of Doxycycline Hydrochloride Tablets, withdraw not less than 20 mL of the medium at the specified minute after starting the test, and filter through a membrane filter with a pore size not exceeding 0.45 μ m. Discard not less than 10 mL of the first filtrate, pipet V mL of the subsequent filtrate, add water to make exactly V' mL so that each mL contains about 11 μ g (potency) of Doxycycline Hydrochloride Hydrate, and use this solution as the sample solution. Separately, weigh accurately about 22 mg (potency) of Doxycycline Hydrochloride RS, dissolve in water to make exactly 100 mL. Pipet 5 mL of this solution, add water to make exactly 100 mL, and use this solution as the standard solution. Determine the absorbances, A_T and A_S , at 274 nm of the sample solution and standard solution as directed under Ultraviolet-visible Spectrophotometry <2.24>.

$$\begin{aligned} &\text{Dissolution rate (\%)} \text{ with respect to the labeled amount} \\ &\text{of doxycycline } (\text{C}_{22}\text{H}_{24}\text{N}_2\text{O}_8) \\ &= M_S \times A_T/A_S \times V'/V \times 1/C \times 45 \end{aligned}$$

M_S : Amount [mg (potency)] of Doxycycline Hydrochloride RS taken

C : Labeled amount [mg(potency)] of doxycycline ($C_{22}H_{24}N_2O_8$) in 1 tablet

Assay To 10 Doxycycline Hydrochloride Tablets add 0.01 mol/L hydrochloric acid TS, disperse them by sonicating, shake for 15 minutes, and add 0.01 mol/L hydrochloric acid TS to make exactly V mL so that each mL contains about 2 mg (potency) of Doxycycline Hydrochloride Hydrate. Centrifuge, if necessary, pipet 10 mL of the supernatant liquid, add 0.01 mol/L hydrochloric acid TS to make exactly 20 mL. Filter this solution through a membrane filter with a pore size not exceeding $0.45 \mu\text{m}$, discard the first 10 mL of the filtrate, and use the subsequent filtrate as the sample solution. Separately, weigh accurately about 20 mg (potency) of Doxycycline Hydrochloride RS, dissolve in 0.01 mol/L hydrochloric acid TS to make exactly 20 mL, and use this solution as the standard solution. Perform the test with exactly $10 \mu\text{L}$ of the sample solution and standard solution as directed under Liquid Chromatography <2.01> according to the following conditions, and determine the peak areas, A_T and A_S , of doxycycline in each solution.

Amount [mg (potency)] of doxycycline ($C_{22}H_{24}N_2O_8$) in 1 tablet
 $= M_S \times A_T / A_S \times V / 100$

M_S : Amount [mg (potency)] of Doxycycline Hydrochloride RS taken

Operating conditions—

Detector: An ultraviolet absorption photometer (wavelength: 270 nm).

Column: A stainless steel column 4.6 mm in inside diameter and 15 cm in length, packed with octadecylsilanized silica gel for liquid chromatography ($5 \mu\text{m}$ in particle diameter).

Column temperature: A constant temperature of about 30°C .

Mobile phase: Dissolve 7.0 g of sodium dihydrogen phosphate dihydrate in 450 mL of water. Add to this solution 553 mL of a mixture of methanol and *N,N*-dimethyl-*n*-octylamine (550:3), and adjust to pH 8.0 with sodium hydroxide solution (43 in 200).

Flow rate: Adjust so that the retention time of doxycycline is about 6 minutes.

System suitability—

System performance: When the procedure is run with $10 \mu\text{L}$ of the standard solution under the above operating conditions, the number of theoretical plates and symmetry factor of the peak of doxycycline are not less than 2200 and not more than 1.6, respectively.

System repeatability: When the test is repeated 6 times with $10 \mu\text{L}$ of the standard solution under the above operating conditions, the relative standard deviation of the peak area of doxycycline is not more than 1.0%.

Containers and storage Containers—Tight containers.

Droperidol

ドロペリドール

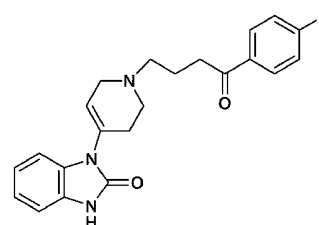

$C_{22}H_{22}FN_3O_2$: 379.43

1-[1-[4-(4-Fluorophenyl)-4-oxobutyl]-1,2,3,6-tetrahydropyridin-4-yl]-1,3-dihydro-2*H*-benzimidazol-2-one
 [548-73-2]

Droperidol, when dried, contains not less than 98.0% of droperidol ($C_{22}H_{22}FN_3O_2$).

Description Droperidol occurs as a white to light yellow powder.

It is freely soluble in acetic acid (100), soluble in dichloromethane, slightly soluble in ethanol (99.5), and practically insoluble in water.

It is gradually colored by light.

It shows crystal polymorphism.

Identification (1) Put 30 mg of Droperidol in a brown volumetric flask, and dissolve in 10 mL of 0.1 mol/L hydrochloric acid TS and ethanol (95) to make 100 mL. Transfer 5 mL of the solution to a brown volumetric flask, and add 10 mL of 0.1 mol/L hydrochloric acid TS and ethanol (95) to make 100 mL. Determine the absorption spectrum of the solution as directed under Ultraviolet-visible Spectrophotometry <2.24>, and compare the spectrum with the Reference Spectrum: both spectra exhibit similar intensities of absorption at the same wavelengths.

(2) Determine the infrared absorption spectrum of Droperidol, previously dried, as directed in the potassium bromide disk method under Infrared Spectrophotometry <2.25>, and compare the spectrum with the Reference Spectrum: both spectra exhibit similar intensities of absorption at the same wave numbers. If any difference appears between the spectra, dissolve Droperidol in acetone, evaporate the acetone, dry the residue in a desiccator (in vacuum, silica gel, 70°C) for 4 hours, and perform the test with the residue.

Purity (1) Heavy metals <1.07>—Proceed with 1.0 g of Droperidol in a platinum crucible according to Method 2, and perform the test. Prepare the control solution with 2.0 mL of Standard Lead Solution (not more than 20 ppm).

(2) Related substances—Conduct this procedure without exposure to light, using light-resistant vessels. Dissolve 50 mg of Droperidol in 5 mL of dichloromethane, and use this solution as the sample solution. Pipet 1 mL of the sample solution, add dichloromethane to make exactly 100 mL, and use this solution as the standard solution. Perform the test with these solutions as directed under Thin-layer Chromatography <2.03>. Spot $10 \mu\text{L}$ each of the sample solution and standard solution on a plate of silica gel with fluorescent indicator for thin-layer chromatography. Develop the plate with a mixture of ethyl acetate, chloroform, methanol and acetic acid-sodium acetate buffer solution (pH 4.7) (54:23:18:5) to a distance of about 15 cm, and air-dry the plate. Examine under ultraviolet light (main wavelength: 254

nm): the spots other than the principal spot obtained from the sample solution are not more intense than the spot from the standard solution.

Loss on drying <2.41> Not more than 3.0% (0.5 g, in vacuum, silica gel, 70°C, 4 hours).

Residue on ignition <2.44> Not more than 0.2% (1 g, platinum crucible).

Assay Weigh accurately about 0.5 g of Droperidol, previously dried, dissolve in 50 mL of acetic acid (100), and titrate <2.50> with 0.1 mol/L perchloric acid VS (potentiometric titration). Perform a blank determination in the same manner, and make any necessary correction.

Each mL of 0.1 mol/L perchloric acid VS
= 37.94 mg of C₂₂H₂₂FN₃O₂

Containers and storage Containers—Tight containers.
Storage—Light-resistant.

Droxidopa

ドロキシドパ

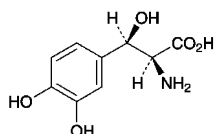

C₉H₁₁NO₅; 213.19
(2*S*,3*R*)-2-Amino-3-(3,4-dihydroxyphenyl)-
3-hydroxypropanoic acid
[23651-95-8]

Droxidopa, when dried, contains not less than 99.0% and not more than 101.0% of droxidopa (C₉H₁₁NO₅).

Description Droxidopa occurs as white to light brown, crystals or crystalline powder.

It is slightly soluble in water and practically insoluble in ethanol (99.5).

It dissolves in 0.1 mol/L hydrochloric acid TS.

Identification (1) Determine the absorption spectrum of a solution of Droxidopa in 0.1 mol/L hydrochloric acid TS (1 in 25,000) as directed under Ultraviolet-visible Spectrophotometry <2.24>, and compare the spectrum with the Reference Spectrum: both spectra exhibit similar intensities of absorption at the same wavelengths.

(2) Determine the infrared absorption spectrum of Droxidopa as directed in the potassium bromide disk method under Infrared Spectrophotometry <2.25>, and compare the spectrum with the Reference Spectrum: both spectra exhibit similar intensities of absorption at the same wave numbers.

Optical rotation <2.49> [α]_D²⁰: −38 – −43° (after drying, 0.1 g, 0.1 mol/L hydrochloric acid TS, 20 mL, 100 mm).

Purity (1) Chloride <1.03>—Dissolve 0.40 g of Droxidopa in 6 mL of dilute nitric acid, and add water to make 50 mL. Perform the test using this solution as the test solution. Prepare the control solution with 0.40 mL of 0.01 mol/L hydrochloric acid VS (not more than 0.036%).

(2) Heavy metals <1.07>—Proceed with 2.0 g of Droxidopa according to Method 2, and perform the test. Prepare the control solution with 2.0 mL of Standard Lead Solution (not more than 10 ppm).

(3) Arsenic <1.11>—Prepare the test solution with 1.0 g of Droxidopa according to Method 3, and perform the test (not more than 2 ppm).

(4) Related substances—To 0.10 g of Droxidopa add 50 mL of 0.1 mol/L hydrochloric acid TS, dissolve by shaking while cooling in an ice bath, and use this solution as the sample solution. Pipet 1 mL of the sample solution, add 0.1 mol/L hydrochloric acid TS to make exactly 100 mL. Pipet 5 mL of this solution, add 0.1 mol/L hydrochloric acid TS to make 50 mL, and use this solution as the standard solution. Perform the test with exactly 10 μL each of the sample solution and standard solution as directed under Liquid Chromatography <2.01> according to the following conditions. Determine each peak area of both solutions by the automatic integration method: the area of each peak other than droxidopa obtained from the sample solution is not larger than the peak area of droxidopa from the standard solution.
Operating conditions—

Detector: An ultraviolet absorption photometer (wavelength: 220 nm).

Column: A stainless steel column 4.6 mm in inside diameter and 15 cm in length, packed with octadecylsilanized silica gel for liquid chromatography (3 μm in particle diameter).

Column temperature: A constant temperature of about 25°C.

Mobile phase: Dissolve 1.0 g of sodium 1-heptanesulfonate and 1.36 g of potassium dihydrogen phosphate in 1000 mL of water, and adjust the pH to 2.0 with phosphoric acid. To 930 mL of this solution add 70 mL of acetonitrile.

Flow rate: Adjust so that the retention time of droxidopa is about 5 minutes.

Time span of measurement: About 12 times as long as the retention time of droxidopa, beginning after the solvent peak.

System suitability—

System performance: When the procedure is run with 10 μL of the standard solution under the above operating conditions, the number of theoretical plates and the symmetry factor of the peak of droxidopa are not less than 10,000 and not more than 1.5, respectively.

System repeatability: When the test is repeated 6 times with 10 μL of the standard solution under the above operating conditions, the relative standard deviation of the peak area of droxidopa is not more than 2.0%.

Loss on drying <2.41> Not more than 0.1% (1 g, in vacuum, 60°C, 3 hours).

Residue on ignition <2.44> Not more than 0.2% (1 g).

Assay Weigh accurately about 0.3 g of Droxidopa, previously dried, dissolve in exactly 20 mL of 0.1 mol/L perchloric acid VS, add 50 mL of acetic acid (100), and titrate <2.50> the excess perchloric acid with 0.1 mol/L sodium acetate VS (potentiometric titration). Perform a blank determination in the same manner, and make any necessary correction.

Each mL of 0.1 mol/L perchloric acid VS
= 21.32 mg of C₉H₁₁NO₅

Containers and storage Containers—Well-closed containers.

Droxidopa Capsules

ドロキシドパカプセル

Droxidopa Capsules contain not less than 93.0% and not more than 107.0% of the labeled amount of droxidopa ($C_9H_{11}NO_5$; 213.19).

Method of preparation Prepare as directed under Capsules, with Droxidopa.

Identification (1) To an amount of the contents of Droxidopa Capsules, equivalent to 50 mg of Droxidopa, add 50 mL of water, shake for 10 minutes, and filter. To 5 mL of the filtrate add 1 mL of ninhydrin TS, and heat in a water bath for 3 minutes: a blue-purple color develops.

(2) To an amount of the contents of Droxidopa Capsules, equivalent to 20 mg of Droxidopa, add 20 mL of diluted acetic acid (100) (1 in 500), shake for 10 minutes, and filter. To 1 mL of the filtrate add 4 mL of water and 1 drop of iron (III) chloride TS: a deep green color is produced, and it gradually changes to light brown.

(3) To an amount of the contents of Droxidopa Capsules, equivalent to 50 mg of Droxidopa, add 50 mL of 0.1 mol/L hydrochloric acid TS, shake well, add 0.1 mol/L hydrochloric acid TS to make 100 mL, and filter. Discard the first 10 mL of the filtrate, and to 2 mL of the subsequent filtrate add 0.1 mol/L hydrochloric acid TS to make 25 mL. Determine the absorption spectrum of this solution as directed under Ultraviolet-visible Spectrophotometry <2.24>: it exhibits a maximum between 278 nm and 282 nm.

Uniformity of dosage units <6.02> Perform the Mass variation test, or the Content uniformity test according to the following method: it meets the requirement.

To the contents of 1 capsule of Droxidopa Capsules, add 100 mL of 0.1 mol/L hydrochloric acid TS, shake well, and add 0.1 mol/L hydrochloric acid TS to make exactly V mL so that each mL contains about 0.5 mg of droxidopa ($C_9H_{11}NO_5$). Filter this solution, discard the first 10 mL of the filtrate, pipet 2 mL of the subsequent filtrate, add 0.1 mol/L hydrochloric acid TS to make exactly 25 mL, and use this solution as the sample solution. Separately, weigh accurately about 50 mg of droxidopa for assay, previously dried in vacuum at 60°C for 3 hours, dissolve in 0.1 mol/L hydrochloric acid TS to make exactly 100 mL. Pipet 2 mL of this solution, add 0.1 mol/L hydrochloric acid TS to make exactly 25 mL, and use this solution as the standard solution. Perform the test with the sample solution and standard solution as directed under Ultraviolet-visible Spectrophotometry <2.24>, and determine the absorbances, A_T and A_S , at 280 nm.

$$\begin{aligned} & \text{Amount (mg) of droxidopa (C}_9\text{H}_{11}\text{NO}_5\text{)} \\ & = M_S \times A_T/A_S \times V/100 \end{aligned}$$

M_S : Amount (mg) of droxidopa for assay taken

Dissolution <6.10> When the test is performed at 75 revolutions per minute according to the Paddle method using the sinker, using 900 mL of water as the dissolution medium, the dissolution rate in 90 minutes of Droxidopa Capsules is not less than 70%.

Start the test with 1 capsule of Droxidopa Capsules, withdraw not less than 20 mL of the medium at the specified minute after starting the test, and filter through a membrane filter with a pore size not exceeding 0.45 μm . Discard not less than 10 mL of the first filtrate, pipet V mL of the subsequent

filtrate, add water to make exactly V' mL so that each mL contains about 56 μg of droxidopa ($C_9H_{11}NO_5$), and use this solution as the sample solution. Separately, weigh accurately about 28 mg of droxidopa for assay, previously dried in vacuum at 60°C for 3 hours, dissolve in water to make exactly 100 mL. Pipet 4 mL of this solution, add water to make exactly 20 mL, and use this solution as the standard solution. Perform the test with the sample solution and standard solution as directed under Ultraviolet-visible Spectrophotometry <2.24>, and determine the absorbances, A_{T1} and A_{S1} , at 280 nm, and A_{T2} and A_{S2} , at 350 nm.

Dissolution rate (%) with respect to the labeled amount of droxidopa ($C_9H_{11}NO_5$)

$$= M_S \times (A_{T1} - A_{T2})/(A_{S1} - A_{S2}) \times V'/V \times 1/C \times 180$$

M_S : Amount (mg) of droxidopa for assay taken

C : Labeled amount (mg) of droxidopa ($C_9H_{11}NO_5$) in 1 capsule

Assay Take out the contents of not less than 20 Droxidopa Capsules, weigh accurately the mass of the contents, and mix uniformly. Weigh accurately an amount equivalent to about 50 mg of droxidopa ($C_9H_{11}NO_5$), add 50 mL of 0.1 mol/L hydrochloric acid TS, shake well, add 0.1 mol/L hydrochloric acid TS to make exactly 100 mL, and filter. Discard the first 10 mL of the filtrate, pipet 2 mL of the subsequent filtrate, add 0.1 mol/L hydrochloric acid TS to make exactly 25 mL, and use this solution as the sample solution. Separately, weigh accurately about 50 mg of droxidopa for assay, previously dried in vacuum at 60°C for 3 hours, dissolve in 0.1 mol/L hydrochloric acid TS to make exactly 100 mL. Pipet 2 mL of this solution, add 0.1 mol/L hydrochloric acid TS to make exactly 25 mL, and use this solution as the standard solution. Perform the test with the sample solution and standard solution as directed under Ultraviolet-visible Spectrophotometry <2.24>, and determine the absorbances, A_T and A_S , at 280 nm.

$$\begin{aligned} & \text{Amount (mg) of droxidopa (C}_9\text{H}_{11}\text{NO}_5\text{)} \\ & = M_S \times A_T/A_S \end{aligned}$$

M_S : Amount (mg) of droxidopa for assay taken

Containers and storage Containers—Tight containers.

Droxidopa Fine Granules

ドロキシドパ細粒

Droxidopa Fine Granules contain not less than 93.0% and not more than 107.0% of the labeled amount of droxidopa ($C_9H_{11}NO_5$; 213.19).

Method of preparation Prepare as directed under Granules, with Droxidopa.

Identification (1) To a quantity of powdered Droxidopa Fine Granules, equivalent to 50 mg of Droxidopa, add 50 mL of water, shake for 10 minutes, and filter. To 5 mL of the filtrate add 1 mL of ninhydrin TS, heat in a water bath for 3 minutes: a blue-purple color develops.

(2) To a quantity of powdered Droxidopa Fine Granules, equivalent to 20 mg of Droxidopa, add 20 mL of diluted acetic acid (100) (1 in 500), shake for 10 minutes, and filter. To 1 mL of the filtrate add 4 mL of water and 1 drop of iron (III) chloride TS: a deep green color is produced, and it gradually changes to light brown.

(3) To a quantity of powdered Droxidopa Fine Granules,

equivalent to 50 mg of Droxidopa, add 50 mL of 0.1 mol/L hydrochloric acid TS, shake well, add 0.1 mol/L hydrochloric acid TS to make 100 mL, and filter. Discard the first 10 mL of the filtrate, to 2 mL of the subsequent filtrate add 0.1 mol/L hydrochloric acid TS to make 25 mL. Determine the absorption spectrum of this solution as directed under Ultraviolet-visible Spectrophotometry <2.24>: it exhibits a maximum between 278 nm and 282 nm.

Dissolution <6.10> When the test is performed at 75 revolutions per minute according to the Paddle method, using 900 mL of water as the dissolution medium, the dissolution rate in 45 minutes of Droxidopa Fine Granules is not less than 70%.

Start the test with an accurately weighed amount of Droxidopa Fine Granules, equivalent to about 0.1 g of droxidopa ($C_9H_{11}NO_5$), withdraw not less than 20 mL of the medium at the specified minute after starting the test, and filter through a membrane filter with a pore size not exceeding 0.45 μ m. Discard not less than 10 mL of the first filtrate, pipet 5 mL of the subsequent filtrate, add exactly 5 mL of water, and use this solution as the sample solution. Separately, weigh accurately about 28 mg of droxidopa for assay, previously dried in vacuum at 60°C for 3 hours, dissolve in water to make exactly 100 mL. Pipet 4 mL of this solution, add water to make exactly 20 mL, and use this solution as the standard solution. Perform the test with the sample solution and standard solution as directed under Ultraviolet-visible Spectrophotometry <2.24>, and determine the absorbances, A_{T1} and A_{S1} , at 280 nm, and A_{T2} and A_{S2} , at 350 nm.

Dissolution rate (%) with respect to the labeled amount of droxidopa ($C_9H_{11}NO_5$)

$$= M_S/M_T \times (A_{T1} - A_{T2})/(A_{S1} - A_{S2}) \times 1/C \times 360$$

M_S : Amount (mg) of droxidopa for assay taken

M_T : Amount (g) of Droxidopa Fine Granules taken

C : Labeled amount (mg) of droxidopa ($C_9H_{11}NO_5$) in 1 g

Assay Powder not less than 20 g of Droxidopa Fine Granules. Weigh accurately a portion of the powder, equivalent to about 50 mg of droxidopa ($C_9H_{11}NO_5$), add 50 mL of 0.1 mol/L hydrochloric acid TS, shake well, add 0.1 mol/L hydrochloric acid TS to make exactly 100 mL, and filter. Discard the first 10 mL of the filtrate, pipet 2 mL of the subsequent filtrate, add 0.1 mol/L hydrochloric acid TS to make exactly 25 mL, and use this solution as the sample solution. Separately, weigh accurately about 50 mg of droxidopa for assay, previously dried in vacuum at 60°C for 3 hours, dissolve in 0.1 mol/L hydrochloric acid TS to make exactly 100 mL. Pipet 2 mL of this solution, add 0.1 mol/L hydrochloric acid TS to make exactly 25 mL, and use this solution as the standard solution. Perform the test with the sample solution and standard solution as directed under Ultraviolet-visible Spectrophotometry <2.24>, and determine the absorbances, A_T and A_S , at 280 nm.

$$\begin{aligned} &\text{Amount (mg) of droxidopa (C}_9\text{H}_{11}\text{NO}_5\text{)} \\ &= M_S \times A_T/A_S \end{aligned}$$

M_S : Amount (mg) of droxidopa for assay taken

Containers and storage Containers—Tight containers.

Dydrogesterone

ジドロゲステロン

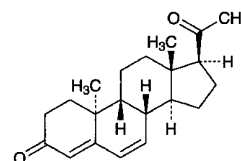

$C_{21}H_{28}O_2$: 312.45

9 β ,10 α -Pregna-4,6-diene-3,20-dione
[152-62-5]

Dydrogesterone, when dried, contains not less than 98.0% and not more than 102.0% of dydrogesterone ($C_{21}H_{28}O_2$).

Description Dydrogesterone occurs as white to light yellow-white, crystals or crystalline powder. It is odorless.

It is freely soluble in chloroform, soluble in acetonitrile, sparingly soluble in methanol and in ethanol (95), slightly soluble in diethyl ether, and practically insoluble in water.

Identification (1) To 5 mg of Dydrogesterone add 5 mL of 4-methoxybenzaldehyde-acetic acid TS and 2 to 3 drops of sulfuric acid, and heat in a water bath for 2 minutes: an orange-red color develops.

(2) Determine the absorption spectrum of a solution of Dydrogesterone in methanol (1 in 200,000) as directed under Ultraviolet-visible Spectrophotometry <2.24>, and compare the spectrum with the Reference Spectrum: both spectra exhibit similar intensities of absorption at the same wavelengths.

(3) Determine the infrared absorption spectrum of Dydrogesterone, previously dried, as directed in the potassium bromide disk method under Infrared Spectrophotometry <2.25>, and compare the spectrum with the Reference Spectrum: both spectra exhibit similar intensities of absorption at the same wave numbers.

Optical rotation <2.49> $[\alpha]_D^{20}$: -470 - -500° (after drying, 0.1 g, chloroform, 10 mL, 100 mm).

Melting point <2.60> 167 - 171°C

Purity (1) Heavy metals <1.07>—Proceed with 1.0 g of Dydrogesterone according to Method 2, and perform the test. Prepare the control solution with 2.0 mL of Standard Lead Solution (not more than 20 ppm).

(2) Related substances—Dissolve 10 mg of Dydrogesterone in 200 mL of the mobile phase, and use this solution as the sample solution. Pipet 1 mL of the sample solution, add the mobile phase to make exactly 100 mL, and use this solution as the standard solution. Perform the test with exactly 10 μ L each of the sample solution and standard solution as directed under Liquid Chromatography <2.01> according to the following conditions. Determine each peak area of these solutions by the automatic integration method: the total area of peaks other than dydrogesterone obtained from the sample solution is not larger than the peak area of dydrogesterone from the standard solution.

Operating conditions—

Detector: An ultraviolet absorption photometer (wavelength: 280 nm).

Column: A stainless steel column about 4 mm in inside diameter and about 15 cm in length, packed with octadecylsilanized silica gel for liquid chromatography (3 μ m in parti-

cle diameter).

Column temperature: A constant temperature of about 40°C.

Mobile phase: A mixture of water, ethanol (95) and acetonitrile (53:26:21).

Flow rate: Adjust so that the retention time of dydrogesterone is about 12 minutes.

Selection of column: Dissolve 1 mg each of Dydrogesterone and progesterone in 20 mL of the mobile phase. Proceed with 10 μ L of the solution under the above operating conditions, and calculate the resolution. Use a column giving elution of dydrogesterone and progesterone in this order with the resolution between these peaks being not less than 8. Wavelength is 265 nm.

Detection sensitivity: Adjust the detection sensitivity so that the peak height of dydrogesterone obtained with 10 μ L of the standard solution is between 5 mm and 10 mm.

Time span of measurement: About twice as long as the retention time of dydrogesterone, beginning after the solvent peak.

Loss on drying <2.41> Not more than 0.5% (0.5 g, in vacuum, phosphorus (V) oxide, 24 hours).

Residue on ignition <2.44> Not more than 0.1% (1 g).

Assay Weigh accurately about 50 mg of Dydrogesterone, previously dried, and dissolve in methanol to make exactly 100 mL. Pipet 1 mL of this solution, and add methanol to make exactly 100 mL. Determine the absorbance A of this solution at the wavelength of maximum absorption at about 286 nm as directed under Ultraviolet-visible Spectrophotometry <2.24>.

$$\begin{aligned} \text{Amount (mg) of dydrogesterone (C}_{21}\text{H}_{28}\text{O}_2) \\ = A/845 \times 100,000 \end{aligned}$$

Containers and storage Containers—Tight containers.

Dydrogesterone Tablets

ジドロゲステロン錠

Dydrogesterone Tablets contain not less than 95.0% and not more than 105.0% of the labeled amount of dydrogesterone (C₂₁H₂₈O₂; 312.45).

Method of preparation Prepare as directed under Tablets, with Dydrogesterone.

Identification (1) To a quantity of powdered Dydrogesterone Tablets, equivalent to 0.05 g of Dydrogesterone, add 50 mL of methanol, shake well, and filter. Evaporate 5 mL of the filtrate on a water bath to dryness. Proceed with the residue as directed in the Identification (1) under Dydrogesterone.

(2) To 1 mL of the filtrate obtained in (1) add methanol to make 200 mL. Determine the absorption spectrum of this solution as directed under Ultraviolet-visible Spectrophotometry <2.24>: it exhibits a maximum between 284 nm and 288 nm.

Uniformity of dosage units <6.02> Perform the test according to the following method: it meets the requirement of the Content uniformity test.

Crush 1 tablet of Dydrogesterone Tablets, and add methanol to make exactly 100 mL. Shake until the tablet is completely disintegrated, and filter through a membrane filter with a pore size not exceeding 0.45 μ m. Discard the first 20

mL of the filtrate, pipet V mL of the subsequent filtrate, add methanol to make exactly V' mL so that each mL contains about 5 μ g of dydrogesterone (C₂₁H₂₈O₂), and use this solution as the sample solution. Then, proceed as directed in the Assay.

$$\begin{aligned} \text{Amount (mg) of dydrogesterone (C}_{21}\text{H}_{28}\text{O}_2) \\ = M_S \times A_T/A_S \times V'/V \times 1/20 \end{aligned}$$

M_S : Amount (mg) of dydrogesterone for assay taken

Dissolution <6.10> When the test is performed at 50 revolutions per minute according to the Paddle method, using 900 mL of water as the dissolution medium, the dissolution rate in 30 minutes of Dydrogesterone Tablets is not less than 80%.

Start the test with 1 tablet of Dydrogesterone Tablets, withdraw not less than 20 mL of the medium at the specified minute after starting the test, and filter. Discard not less than 10 mL of the first filtrate, pipet V mL of the subsequent filtrate, add water to make exactly V' mL so that each mL contains about 56 μ g of dydrogesterone (C₂₁H₂₈O₂), and use this solution as the sample solution. Separately, weigh accurately about 50 mg of dydrogesterone for assay, previously dried in a desiccator (in vacuum, phosphorus (V) oxide) for 24 hours, and dissolve in methanol to make exactly 100 mL. Pipet 1 mL of this solution, add water to make exactly 100 mL, and use this solution as the standard solution. Determine the absorbances, A_T and A_S , of the sample solution and standard solution at 296 nm as directed under Ultraviolet-visible Spectrophotometry <2.24>, using water as the control.

$$\begin{aligned} \text{Dissolution rate (\%)} \text{ with respect to the labeled amount} \\ \text{of dydrogesterone (C}_{21}\text{H}_{28}\text{O}_2) \\ = M_S \times A_T/A_S \times V'/V \times 1/C \times 9 \end{aligned}$$

M_S : Amount (mg) of dydrogesterone for assay taken

C : Labeled amount (mg) of dydrogesterone (C₂₁H₂₈O₂) in 1 tablet.

Assay Weigh accurately and powder not less than 20 Dydrogesterone Tablets. Weigh accurately a portion of the powder, equivalent to about 10 mg of dydrogesterone (C₂₁H₂₈O₂), shake with 50 mL of methanol, and add methanol to make exactly 100 mL, and filter through a membrane filter with a pore size not exceeding 0.45 μ m. Discard the first 20 mL of the filtrate, pipet 5 mL of the subsequent filtrate, add methanol to make exactly 100 mL, and use this solution as the sample solution. Separately, weigh accurately about 10 mg of dydrogesterone for assay, previously dried in vacuum for 24 hours using phosphorus (V) oxide as a desiccant, and dissolve in methanol to make exactly 100 mL. Pipet 5 mL of this solution, add methanol to make exactly 100 mL, and use the solution as the standard solution. Determine the absorbances, A_T and A_S , of the sample solution and standard solution at 286 nm as directed under Ultraviolet-visible Spectrophotometry <2.24>.

$$\begin{aligned} \text{Amount (mg) of dydrogesterone (C}_{21}\text{H}_{28}\text{O}_2) \\ = M_S \times A_T/A_S \end{aligned}$$

M_S : Amount (mg) of dydrogesterone for assay taken

Containers and storage Containers—Tight containers.

Ebastine

エバスチン

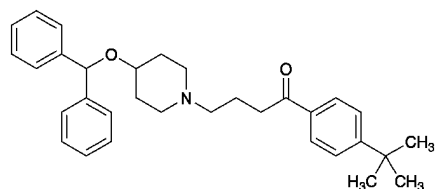

$C_{32}H_{39}NO_2$: 469.66

1-[4-(1,1-Dimethylethyl)phenyl]-

4-[4-(diphenylmethoxy)piperidin-1-yl]butan-1-one

[90729-43-4]

Ebastine, when dried, contains not less than 99.0% and not more than 101.0% of ebastine ($C_{32}H_{39}NO_2$).

Description Ebastine occurs as white, crystals or crystalline powder.

It is freely soluble in acetic acid (100), soluble in methanol, sparingly soluble in ethanol (95), and practically insoluble in water.

It gradually becomes yellowish white on exposure to light.

Identification (1) Dissolve 20 mg of Ebastine in 5 mL of ethanol (95), add 2 mL of 1,3-dinitrobenzene TS and 2 mL of sodium hydroxide TS, and allow to stand: the color of the solution is purple to red-purple, which gradually changes to brown.

(2) Determine the absorption spectrum of a solution of Ebastine in methanol (1 in 100,000) as directed under Ultraviolet-visible Spectrophotometry <2.24>, and compare the spectrum with the Reference Spectrum: both spectra exhibit similar intensities of absorption at the same wavelengths.

(3) Determine the infrared absorption spectrum of Ebastine as directed in the potassium bromide disk method under Infrared Spectrophotometry <2.25>, and compare the spectrum with the Reference Spectrum: both spectra exhibit similar intensities of absorption at the same wave numbers.

Melting point <2.60> 84 – 87°C

Purity (1) Heavy metals <1.07>—Proceed with 1.0 g of Ebastine according to Method 2, and perform the test. Prepare the control solution with 2.0 mL of Standard Lead Solution (not more than 20 ppm). A platinum crucible may be used.

(2) Related substances—Dissolve 0.10 g of Ebastine in 50 mL of the mobile phase, and use this solution as the sample solution. Pipet 5 mL of the sample solution, and add the mobile phase to make exactly 100 mL. Pipet 2 mL of this solution, add the mobile phase to make exactly 100 mL, and use this solution as the standard solution. Perform the test with exactly 10 μ L each of the sample solution and standard solution as directed under Liquid Chromatography <2.01> according to the following conditions, and determine each peak area by the automatic integration method: each peak area other than ebastine obtained from the sample solution is not larger than the peak area of ebastine from the standard solution, and the total area of the peaks other than ebastine from the sample solution is not larger than 4 times the peak area of ebastine from the standard solution.

Operating conditions—

Detector: An ultraviolet absorption photometer (wavelength: 220 nm).

Column: A stainless steel column 4.6 mm in inside diame-

ter and 15 cm in length, packed with octadecylsilanized silica gel for liquid chromatography (5 μ m in particle diameter).

Column temperature: A constant temperature of about 40°C.

Mobile phase: Dissolve 7.8 g of sodium dihydrogen phosphate dihydrate in 900 mL of water, adjust to pH 3.0 with diluted phosphoric acid (1 in 5), and add water to make 1000 mL. To 375 mL of this solution add 625 mL of acetonitrile for liquid chromatography, and dissolve 0.72 g of sodium lauryl sulfate in this solution.

Flow rate: Adjust so that the retention time of ebastine is about 9 minutes.

Time span of measurement: About 2 times as long as the retention time of ebastine, beginning after the solvent peak. **System suitability**—

Test for required detectability: Pipet 5 mL of the standard solution, and add the mobile phase to make exactly 10 mL. Confirm that the peak area of ebastine obtained with 10 μ L of this solution is equivalent to 35 to 65% of that with 10 μ L of the standard solution.

System performance: When the procedure is run with 10 μ L of the standard solution under the above operating conditions, the number of theoretical plates and the symmetry factor of the peak of ebastine are not less than 6000 and not more than 1.5, respectively.

System repeatability: When the test is repeated 6 times with 10 μ L of the standard solution under the above operating conditions, the relative standard deviation of the peak area of ebastine is not more than 2.0%.

Loss on drying <2.41> Not more than 0.5% (1 g, in vacuum, phosphorus (V) oxide, 60°C, 2 hours).

Residue on ignition <2.44> Not more than 0.1% (1 g).

Assay Weigh accurately about 0.5 g of Ebastine, previously dried, dissolve in 60 mL of acetic acid (100), and titrate <2.50> with 0.1 mol/L perchloric acid VS (potentiometric titration). Perform a blank determination in the same manner, and make any necessary correction.

Each mL of 0.1 mol/L perchloric acid VS
= 46.97 mg of $C_{32}H_{39}NO_2$

Containers and storage Containers—Well-closed containers.

Storage—Light-resistant.

Ebastine Orally Disintegrating Tablets

エバスチン口腔内崩壊錠

Ebastine Orally Disintegrating Tablets contain not less than 95.0% and not more than 105.0% of the labeled amount of ebastine ($C_{32}H_{39}NO_2$: 469.66).

Method of preparation Prepare as directed under Tablets, with Ebastine.

Identification Powder Ebastine Orally Disintegrating Tablets. To a portion of the powder, equivalent to 30 mg of Ebastine, add 70 mL of methanol, shake for 10 minutes, then add methanol to make 100 mL, and centrifuge. To 5 mL of the supernatant liquid add methanol to make 100 mL. Determine the absorption spectrum of this solution as directed under Ultraviolet-visible Spectrophotometry <2.24>: it exhibits a maximum between 251 nm and 255 nm.

Purity Related substances—Powder Ebastine Orally Disintegrating Tablets. To a portion of the powder, equivalent to 50 mg of Ebastine, add 30 mL of methanol for liquid chromatography, shake for 10 minutes, and add the mobile phase to make 50 mL. Centrifuge this solution, and use the supernatant liquid as the sample solution. Pipet 1 mL of the sample solution, add the mobile phase to make exactly 200 mL, and use this solution as the standard solution. Perform the test with exactly 10 μ L each of the sample solution and standard solution as directed under Liquid Chromatography <2.01> according to the following conditions, and determine each peak area by the automatic integration method: the area of the peak other than ebastine obtained from the sample solution is not larger than the peak area of ebastine from the standard solution, and the total area of the peaks other than ebastine from the sample solution is not larger than 2 times the peak area of ebastine from the standard solution.

Operating conditions—

Column, column temperature, mobile phase, and flow rate: Proceed as directed in the operating conditions in the Assay.

Detector: An ultraviolet absorption photometer (wavelength: 220 nm).

Time span of measurement: About 3 times as long as the retention time of ebastine, beginning after the solvent peak.

System suitability—

Test for required detectability: Pipet 10 mL of the standard solution, and add the mobile phase to make exactly 50 mL. Confirm that the peak area of ebastine obtained with 10 μ L of this solution is equivalent to 15 to 25% of that with 10 μ L of the standard solution.

System performance: When the procedure is run with 10 μ L of the standard solution under the above operating conditions, the number of theoretical plates and the symmetry factor of the peak of ebastine are not less than 6000 and not more than 1.5, respectively.

System repeatability: When the test is repeated 6 times with 10 μ L of the standard solution under the above operating conditions, the relative standard deviation of the peak area of ebastine is not more than 2.0%.

Uniformity of dosage units <6.02> Perform the test according to the following method: it meets the requirement of the Content uniformity test.

To 1 tablet of Ebastine Orally Disintegrating Tablets add $V/10$ mL of 0.1 mol/L hydrochloric acid TS, and disperse the particles by sonicating with occasional shaking. Add $3V/5$ mL of methanol, shake for 10 minutes, then add methanol to make exactly V mL so that each mL contains about 0.1 mg of ebastine ($C_{32}H_{39}NO_2$), and centrifuge. Pipet 5 mL of the supernatant liquid, add exactly 5 mL of the internal standard solution, and use this solution as the sample solution. Then, proceed as directed in the Assay.

$$\begin{aligned} &\text{Amount (mg) of ebastine (C}_{32}\text{H}_{39}\text{NO}_2\text{)} \\ &= M_S \times Q_T/Q_S \times V/500 \end{aligned}$$

M_S : Amount (mg) of ebastine for assay taken

Internal standard solution—A solution of diphenyl in the mobile phase (1 in 40,000).

Disintegration Being specified separately when the drug is granted approval based on the Law.

Dissolution <6.10> When the test is performed at 50 revolutions per minute according to the Paddle method, using 900 mL of 1st fluid for dissolution test as the dissolution medium, the dissolution rate in 15 minutes of Ebastine Orally Disintegrating Tablets is not less than 80%.

Start the test with 1 tablet of Ebastine Orally Disintegrating Tablets, withdraw not less than 20 mL of the medium at the specified minute after starting the test, and filter through a membrane filter with a pore size not exceeding 0.45 μ m. Discard not less than 10 mL of the first filtrate, pipet V mL of the subsequent filtrate, add the dissolution medium to make exactly V' mL so that each mL contains about 5.6 μ g of ebastine ($C_{32}H_{39}NO_2$), and use this solution as the sample solution. Separately, weigh accurately about 28 mg of ebastine for assay, previously dried at 60°C under reduced pressure with phosphorous (V) oxide for 2 hours, and dissolve in methanol to make exactly 50 mL. Pipet 1 mL of this solution, add the dissolution medium to make exactly 100 mL, and use this solution as the standard solution. Determine the absorbances, A_T and A_S , of the sample solution and standard solution at 258 nm as directed under Ultraviolet-visible Spectrophotometry <2.24>, using the dissolution medium as the blank.

Dissolution rate (%) with respect to the labeled amount of ebastine ($C_{32}H_{39}NO_2$)

$$= M_S \times A_T/A_S \times V'/V \times 1/C \times 18$$

M_S : Amount (mg) of ebastine for assay taken

C : Labeled amount (mg) of ebastine ($C_{32}H_{39}NO_2$) in 1 tablet

Assay Weigh accurately the mass of not less than 20 Ebastine Orally Disintegrating Tablets, and powder. Weigh accurately a portion of the powder, equivalent to about 20 mg of ebastine ($C_{32}H_{39}NO_2$), add 20 mL of 0.1 mol/L hydrochloric acid TS, and disperse the particles by sonicating. Add 120 mL of methanol, shake for 10 minutes, add methanol to make exactly 200 mL, and centrifuge. Pipet 5 mL of the supernatant liquid, add exactly 5 mL of the internal standard solution, and use this solution as the sample solution. Separately, weigh accurately about 50 mg of ebastine for assay, previously dried at 60°C under reduced pressure with phosphorous (V) oxide for 2 hours, and dissolve in methanol to make exactly 50 mL. Pipet 5 mL of this solution, add 5 mL of 0.1 mol/L hydrochloric acid TS, and add methanol to make exactly 50 mL. Pipet 5 mL of this solution, add exactly 5 mL of the internal standard solution, and use this solution as the standard solution. Perform the test with 10 μ L each of the sample solution and standard solution as directed under Liquid Chromatography <2.01> according to the following conditions, and calculate the ratios, Q_T and Q_S , of the peak area of ebastine to that of the internal standard.

$$\begin{aligned} &\text{Amount (mg) of ebastine (C}_{32}\text{H}_{39}\text{NO}_2\text{)} \\ &= M_S \times Q_T/Q_S \times 2/5 \end{aligned}$$

M_S : Amount (mg) of ebastine for assay taken

Internal standard solution—A solution of diphenyl in the mobile phase (1 in 40,000).

Operating conditions—

Detector: An ultraviolet absorption photometer (wavelength: 254 nm).

Column: A stainless steel column 4.6 mm in inside diameter and 15 cm in length, packed with octadecylsilanized silica gel for liquid chromatography (5 μ m in particle diameter).

Column temperature: A constant temperature of about 40°C.

Mobile phase: Dissolve 7.8 g of sodium dihydrogen phosphate dihydrate in 900 mL of water, adjust to pH 3.0 with diluted phosphoric acid (1 in 5), and add water to make 1000 mL. To 375 mL of this solution add 625 mL of acetonitrile for liquid chromatography, and dissolve 0.72 g of sodium lauryl sulfate in this solution.

Flow rate: Adjust so that the retention time of ebastine is about 9 minutes.

System suitability—

System performance: When the procedure is run with 10 μ L of the standard solution under the above operating conditions, the internal standard and ebastine are eluted in this order with the resolution between these peaks being not less than 5.

System repeatability: When the test is repeated 6 times with 10 μ L of the standard solution under the above operating conditions, the relative standard deviation of the ratio of the peak area of ebastine to that of the internal standard is not more than 1.0%.

Containers and storage Containers—Tight containers.

Storage—Light-resistant.

Ebastine Tablets

エバスチン錠

Ebastine Tablets contain not less than 95.0% and not more than 105.0% of the labeled amount of ebastine ($C_{32}H_{39}NO_2$; 469.66).

Method of preparation Prepare as directed under Tablets, with Ebastine.

Identification Powder Ebastine Tablets. To a portion of the powder, equivalent to 30 mg of Ebastine, add 70 mL of methanol, shake for 10 minutes, then add methanol to make 100 mL, and centrifuge. To 5 mL of the supernatant liquid add methanol to make 100 mL. Determine the absorption spectrum of this solution as directed under Ultraviolet-visible Spectrophotometry <2.24>: it exhibits a maximum between 251 nm and 255 nm.

Purity Related substances—Powder Ebastine Tablets. To a portion of the powder, equivalent to 50 mg of Ebastine, add 30 mL of methanol for liquid chromatography, shake for 10 minutes, and add the mobile phase to make 50 mL. Centrifuge this solution, and use the supernatant liquid as the sample solution. Pipet 1 mL of the sample solution, add the mobile phase to make exactly 200 mL, and use this solution as the standard solution. Perform the test with exactly 10 μ L each of the sample solution and standard solution as directed under Liquid Chromatography <2.01> according to the following conditions, and determine each peak area by the automatic integration method: the area of the peak other than ebastine obtained from the sample solution is not larger than the peak area of ebastine from the standard solution, and the total area of the peaks other than ebastine from the sample solution is not larger than 2 times the peak area of ebastine from the standard solution.

Operating conditions—

Column, column temperature, mobile phase, and flow rate: Proceed as directed in the operating conditions in the Assay.

Detector: An ultraviolet absorption photometer (wavelength: 220 nm).

Time span of measurement: About 3 times as long as the retention time of ebastine, beginning after the solvent peak.

System suitability—

Test for required detectability: Pipet 10 mL of the standard solution, and add the mobile phase to make exactly 50 mL. Confirm that the peak area of ebastine obtained with 10 μ L of this solution is equivalent to 15 to 25% of that ob-

tained with 10 μ L of the standard solution.

System performance: When the procedure is run with 10 μ L of the standard solution under the above operating conditions, the number of theoretical plates and the symmetry factor of the peak of ebastine are not less than 6000 and not more than 1.5, respectively.

System repeatability: When the test is repeated 6 times with 10 μ L of the standard solution under the above operating conditions, the relative standard deviation of the peak area of ebastine is not more than 2.0%.

Uniformity of dosage units <6.02> Perform the test according to the following method: it meets the requirement of the Content uniformity test.

To 1 tablet of Ebastine Tablets add $V/10$ mL of 0.1 mol/L hydrochloric acid TS, and disperse the particles by sonicating with occasional shaking. Add $3V/5$ mL of methanol, shake for 10 minutes, then add methanol to make exactly V mL so that each mL contains about 0.1 mg of ebastine ($C_{32}H_{39}NO_2$), and centrifuge. Pipet 5 mL of the supernatant liquid, add exactly 5 mL of the internal standard solution, and use this solution as the sample solution. Then, proceed as directed in the Assay.

$$\begin{aligned} & \text{Amount (mg) of ebastine (C}_{32}\text{H}_{39}\text{NO}_2\text{)} \\ & = M_S \times Q_T/Q_S \times V/500 \end{aligned}$$

M_S : Amount (mg) of ebastine for assay taken

Internal standard solution—A solution of diphenyl in the mobile phase (1 in 40,000).

Dissolution <6.10> When the test is performed at 50 revolutions per minute according to the Paddle method, using 900 mL of 1st fluid for dissolution test as the dissolution medium, the dissolution rate in 30 minutes of Ebastine Tablets is not less than 75%.

Start the test with 1 tablet of Ebastine Tablets, withdraw not less than 20 mL of the medium at the specified minute after starting the test, and filter through a membrane filter with a pore size not exceeding 0.45 μ m. Discard not less than 10 mL of the first filtrate, pipet V mL of the subsequent filtrate, add the dissolution medium to make exactly V' mL so that each mL contains about 5.6 μ g of ebastine ($C_{32}H_{39}NO_2$), and use this solution as the sample solution. Separately, weigh accurately about 28 mg of ebastine for assay, previously dried at 60°C under reduced pressure with phosphorous (V) oxide for 2 hours, and dissolve in methanol to make exactly 50 mL. Pipet 1 mL of this solution, add the dissolution medium to make exactly 100 mL, and use this solution as the standard solution. Determine the absorbances, A_T and A_S , of the sample solution and standard solution at 258 nm as directed under Ultraviolet-visible Spectrophotometry <2.24>, using the dissolution medium as the blank.

Dissolution rate (%) with respect to the labeled amount of ebastine ($C_{32}H_{39}NO_2$)

$$= M_S \times A_T/A_S \times V'/V \times 1/C \times 18$$

M_S : Amount (mg) of ebastine for assay taken

C : Labeled amount (mg) of ebastine ($C_{32}H_{39}NO_2$) in 1 tablet

Assay Weigh accurately the mass of not less than 20 Ebastine Tablets, and powder. Weigh accurately a portion of the powder, equivalent to about 20 mg of ebastine ($C_{32}H_{39}NO_2$), add 20 mL of 0.1 mol/L hydrochloric acid TS, and disperse the particles by sonicating. Add 120 mL of methanol, shake for 10 minutes, add methanol to make exactly 200 mL, and centrifuge. Pipet 5 mL of the supernatant liquid, add exactly 5 mL of the internal standard solution,

and use this solution as the sample solution. Separately, weigh accurately about 50 mg of ebastine for assay, previously dried at 60°C under reduced pressure with phosphorous (V) oxide for 2 hours, and dissolve in methanol to make exactly 50 mL. Pipet 5 mL of this solution, add 5 mL of 0.1 mol/L hydrochloric acid TS, and add methanol to make exactly 50 mL. Pipet 5 mL of this solution, add exactly 5 mL of the internal standard solution, and use this solution as the standard solution. Perform the test with 10 μ L each of the sample solution and standard solution as directed under Liquid Chromatography <2.01> according to the following conditions, and calculate the ratios, Q_T and Q_S , of the peak area of ebastine to that of the internal standard.

$$\begin{aligned} \text{Amount (mg) of ebastine (C}_{32}\text{H}_{39}\text{NO}_2) \\ = M_S \times Q_T / Q_S \times 2/5 \end{aligned}$$

M_S : Amount (mg) of ebastine for assay taken

Internal standard solution—A solution of diphenyl in the mobile phase (1 in 40,000).

Operating conditions—

Detector: An ultraviolet absorption photometer (wavelength: 254 nm).

Column: A stainless steel column 4.6 mm in inside diameter and 15 cm in length, packed with octadecylsilanized silica gel for liquid chromatography (5 μ m in particle diameter).

Column temperature: A constant temperature of about 40°C.

Mobile phase: Dissolve 7.8 g of sodium dihydrogen phosphate dihydrate in 900 mL of water, adjust to pH 3.0 with diluted phosphoric acid (1 in 5), and add water to make 1000 mL. To 375 mL of this solution add 625 mL of acetonitrile for liquid chromatography, and dissolve 0.72 g of sodium lauryl sulfate in this solution.

Flow rate: Adjust so that the retention time of ebastine is about 9 minutes.

System suitability—

System performance: When the procedure is run with 10 μ L of the standard solution under the above operating conditions, the internal standard and ebastine are eluted in this order with the resolution between these peaks being not less than 5.

System repeatability: When the test is repeated 6 times with 10 μ L of the standard solution under the above operating conditions, the relative standard deviation of the ratio of the peak area of ebastine to that of the internal standard is not more than 1.0%.

Containers and storage Containers—Tight containers.

Ecabet Sodium Hydrate

エカベトナトリウム水和物

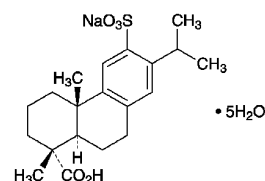

$\text{C}_{20}\text{H}_{27}\text{NaO}_5\text{S} \cdot 5\text{H}_2\text{O}$: 492.56
(1*R*,4*aS*,10*aR*)-1,4*a*-Dimethyl-7-(1-methylethyl)-6-sodiumsulfonato-1,2,3,4,4*a*,9,10,10*a*-octahydrophenanthrene-1-carboxylic acid pentahydrate [219773-47-4]

Ecabet Sodium Hydrate contains not less than 98.5% and not more than 101.5% of ecabet sodium ($\text{C}_{20}\text{H}_{27}\text{NaO}_5\text{S}$: 402.48), calculated on the anhydrous basis.

Description Ecabet Sodium Hydrate is white crystals.

It is freely soluble in methanol, and slightly soluble in water and in ethanol (99.5).

It dissolves in sodium hydroxide TS.

Dissolve 1.0 g of Ecabet Sodium Hydrate in 200 mL of water: the pH of the solution is about 3.5.

Identification (1) Determine the absorption spectrum of a solution of Ecabet Sodium Hydrate in dilute sodium hydroxide TS (3 in 10,000) as directed under Ultraviolet-visible Spectrophotometry <2.24>, and compare the spectrum with the Reference Spectrum: both spectra exhibit similar intensities of absorption at the same wavelengths.

(2) Determine the infrared absorption spectrum of Ecabet Sodium Hydrate as directed in the potassium bromide disk method under Infrared Spectrophotometry <2.25>, and compare the spectrum with the Reference Spectrum: both spectra exhibit similar intensities of absorption at the same wave numbers.

(3) Place 1 g of Ecabet Sodium Hydrate in a porcelain crucible, and carbonize. After cooling, add 0.5 mL of nitric acid, heat gradually to incinerate, and dissolve the residue in 10 mL of water: the solution responds to Qualitative Tests <1.09> for sodium salt.

Optical rotation <2.49> $[\alpha]_D^{20}$: +69 – +76° (0.25 g calculated on the anhydrous basis, methanol, 25 mL, 100 mm).

Purity (1) Heavy metals <1.07>—Proceed with 2.0 g of Ecabet Sodium Hydrate according to Method 2, and perform the test. Prepare the control solution with 2.0 mL of Standard Lead Solution (not more than 10 ppm).

(2) Related substances—Dissolve 10 mg of Ecabet Sodium Hydrate in 10 mL of the mobile phase, and use this solution as the sample solution. Pipet 2 mL of the sample solution, add the mobile phase to make exactly 20 mL. Pipet 1 mL of this solution, add the mobile phase to make exactly 100 mL, and use this solution as the standard solution. Perform the test with exactly 20 μ L each of the sample solution and standard solution as directed under Liquid Chromatography <2.01> according to the following conditions. Determine each peak area by the automatic integration method: the area of each peak other than ecabet obtained from the sample solution is not larger than the peak area of ecabet from the standard solution.

Operating conditions—

Detector: An ultraviolet absorption photometer (wavelength: 225 nm).

Column: A stainless steel column 4.6 mm in inside diameter and 15 cm in length, packed with octadecylsilanized silica gel for liquid chromatography (5 μ m in particle diameter).

Column temperature: A constant temperature of about 40°C.

Mobile phase: To 0.1 mol/L potassium dihydrogen phosphate TS add phosphoric acid to adjust the pH to 3.0. To 730 mL of this solution add 270 mL of acetonitrile.

Flow rate: Adjust so that the retention time of ecabet is about 8 minutes.

Time span of measurement: About 2 times as long as the retention time of ecabet, beginning after the solvent peak.

System suitability—

System performance: When the procedure is run with 20 μ L of the standard solution under the above operating conditions, the number of theoretical plates and the symmetry factor of the peak of ecabet are not less than 5000 and not more than 1.5, respectively.

System repeatability: When the test is repeated 6 times with 20 μ L of the standard solution under the above operating conditions, the relative standard deviation of the peak area of ecabet is not more than 2.0%.

Water <2.48> 17.3 – 19.2% (0.2 g, volumetric titration, direct titration).

Assay Weigh accurately about 1.2 g of Ecabet Sodium Hydrate, dissolve in 30 mL of methanol, add 30 mL of water, and titrate <2.50> with 0.1 mol/L sodium hydroxide VS (indicator: 4 drops of phenolphthalein TS). Perform a blank determination in the same manner, and make any necessary correction.

$$\begin{aligned} \text{Each mL of 0.1 mol/L sodium hydroxide VS} \\ = 40.25 \text{ mg of } C_{20}H_{27}NaO_5S \end{aligned}$$

Containers and storage Containers—Well-closed containers.

Ecabet Sodium Granules

エカベトナトリウム顆粒

Ecabet Sodium Granules contain not less than 95.0% and not more than 105.0% of the labeled amount of ecabet sodium hydrate ($C_{20}H_{27}NaO_5S \cdot 5H_2O$: 492.56).

Method of preparation Prepare as directed under Granules, with Ecabet Sodium Hydrate.

Identification To a quantity of Ecabet Sodium Granules, equivalent to 50 mg of Ecabet Sodium Hydrate, add 25 mL of dilute sodium hydroxide TS, shake, and filter. Discard the first 10 mL of the filtrate, and to 3 mL of the subsequent filtrate add dilute sodium hydroxide TS to make 20 mL. Determine the absorption spectrum of this solution as directed under Ultraviolet-visible Spectrophotometry <2.24>: it exhibits maxima between 269 nm and 273 nm, and between 278 nm and 282 nm.

Uniformity of dosage units <6.02> Perform the test according to the following method: Ecabet Sodium Granules in single-dose packages meet the requirement of the Content uniformity test.

Take out the total amount of the content of 1 package of

Ecabet Sodium Granules, add 70 mL of dilute sodium hydroxide TS, sonicate for 5 minutes with occasional shaking, add dilute sodium hydroxide TS to make exactly V mL so that each mL contains about 10 mg of ecabet sodium hydrate ($C_{20}H_{27}NaO_5S \cdot 5H_2O$), and filter. Discard the first 10 mL of the filtrate, pipet 2 mL of the subsequent filtrate, add water to make exactly 50 mL, and use this solution as the sample solution. Separately, weigh accurately about 20 mg of ecabet sodium hydrate for assay (separately, determine the water <2.48> in the same manner as Ecabet Sodium Hydrate), dissolve in 2 mL of dilute sodium hydroxide TS, add water to make exactly 50 mL, and use this solution as the standard solution. Determine the absorbances, A_T and A_S , of the sample solution and standard solution at 271 nm as directed under Ultraviolet-visible Spectrophotometry <2.24>, using water as the blank.

$$\begin{aligned} \text{Amount (mg) of ecabet sodium hydrate} \\ (C_{20}H_{27}NaO_5S \cdot 5H_2O) \\ = M_S \times A_T / A_S \times V / 2 \times 1.224 \end{aligned}$$

M_S : Amount (mg) of ecabet sodium hydrate for assay taken, calculated on the anhydrous basis

Dissolution <6.10> When the test is performed at 50 revolutions per minute according to the Paddle method, using 900 mL of water as the dissolution medium, the dissolution rate in 30 minutes of Ecabet Sodium Granules is not less than 80%.

Start the test with an accurately weighed amount of Ecabet Sodium Granules, equivalent to about 1 g of Ecabet Sodium Hydrate, withdraw not less than 20 mL of the medium at the specified minute after starting the test, and filter through a membrane filter with a pore size not exceeding 0.45 μ m. Discard not less than 10 mL of the first filtrate, pipet 2 mL of the subsequent filtrate, add water to make exactly 10 mL, and use this solution as the sample solution. Separately, weigh accurately about 22 mg of ecabet sodium hydrate for assay (separately, determine the water <2.48> in the same manner as Ecabet Sodium Hydrate), dissolve in 1 mL of methanol, add water to make exactly 100 mL, and use this solution as the standard solution. Determine the absorbances, A_T and A_S , at 271 nm of the sample solution and standard solution as directed under Ultraviolet-visible Spectrophotometry <2.24>, using water as the blank.

$$\begin{aligned} \text{Dissolution rate (\%)} \text{ with respect to the labeled amount} \\ \text{of ecabet sodium hydrate } (C_{20}H_{27}NaO_5S \cdot 5H_2O) \\ = M_S / M_T \times A_T / A_S \times 1 / C \times 4500 \times 1.224 \end{aligned}$$

M_S : Amount (mg) of ecabet sodium hydrate for assay taken, calculated on the anhydrous basis

M_T : Amount (g) of Ecabet Sodium Granules taken

C : Labeled amount (mg) of ecabet sodium hydrate ($C_{20}H_{27}NaO_5S \cdot 5H_2O$) in 1 g

Assay Weigh accurately an amount of Ecabet Sodium Granules, equivalent to about 30 mg of ecabet sodium hydrate ($C_{20}H_{27}NaO_5S \cdot 5H_2O$), add exactly 5 mL of the internal standard solution, add 25 mL of diluted methanol (1 in 2), shake vigorously for 20 minutes, and filter through a membrane filter with a pore size not exceeding 0.45 μ m. Discard the first 5 mL of the filtrate, to 3 mL of the subsequent filtrate add the mobile phase to make 50 mL, and use this solution as the sample solution. Separately, weigh accurately about 30 mg of ecabet sodium hydrate for assay (separately, determine the water <2.48> in the same manner as Ecabet Sodium Hydrate), add exactly 5 mL of the internal standard solution, and dissolve in dilute methanol (1 in 2) to make 30 mL. To 3 mL of this solution add the mobile phase to make

50 mL, and use this solution as the standard solution. Perform the test with 20 μ L each of the sample solution and standard solution as directed under Liquid Chromatography <2.01> according to the following conditions, and calculate the ratios, Q_T and Q_S , of the peak area of ecabet to that of the internal standard.

$$\begin{aligned} & \text{Amount (mg) of ecabet sodium hydrate} \\ & (\text{C}_{20}\text{H}_{27}\text{NaO}_5\text{S}\cdot 5\text{H}_2\text{O}) \\ & = M_S \times Q_T / Q_S \times 1.224 \end{aligned}$$

M_S : Amount (mg) of ecabet sodium hydrate for assay taken, calculated on the anhydrous basis

Internal standard solution—A solution of ethyl parahydroxybenzoate in diluted methanol (1 in 2) (3 in 400).

Operating conditions—

Detector: An ultraviolet absorption photometer (wavelength: 225 nm).

Column: A stainless steel column 4.6 mm in inside diameter and 15 cm in length, packed with octadecylsilanized silica gel for liquid chromatography (5 μ m in particle diameter).

Column temperature: A constant temperature of about 40°C.

Mobile phase: To 0.1 mol/L potassium dihydrogen phosphate TS add phosphoric acid to adjust the pH to 3.0. To 730 mL of this solution add 270 mL of acetonitrile.

Flow rate: Adjust so that the retention time of ecabet is about 8 minutes.

System suitability—

System performance: When the procedure is run with 20 μ L of the standard solution under the above operating conditions, ecabet and the internal standard are eluted in this order with the resolution between these peaks being not less than 6.

System repeatability: When the test is repeated 6 times with 20 μ L of the standard solution under the above operating conditions, the relative standard deviation of the ratio of the peak area of ecabet to that of the internal standard is not more than 1.0%.

Containers and storage Containers—Well-closed containers.

Ecothiopate Iodide

エコチオパートヨウ化物

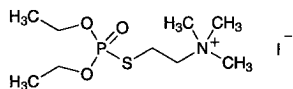

$\text{C}_9\text{H}_{23}\text{INO}_3\text{PS}$: 383.23

2-(Diethoxyphosphorylsulfanyl)-*N,N,N*-trimethylethylamminium iodide

[513-10-0]

Ecothiopate Iodide contains not less than 95.0% of ecothiopate iodide ($\text{C}_9\text{H}_{23}\text{INO}_3\text{PS}$), calculated on the dried basis.

Description Ecothiopate Iodide occurs as white, crystals or crystalline powder.

It is very soluble in water, freely soluble in methanol, slightly soluble in ethanol (95), and practically insoluble in diethyl ether.

Identification (1) Dissolve 0.1 g of Ecothiopate Iodide in 2 mL of water, and add 1 mL of nitric acid: a brown precipitate is formed. To 1 drop of the turbid solution containing this precipitate add 1 mL of hexane, and shake: a light red color develops in the hexane layer.

(2) Heat the suspension of the precipitate obtained in (1) until it becomes colorless, cool, add 10 mL of water, and use this solution as the sample solution. Two mL of the sample solution responds to Qualitative Tests <1.09> (2) for phosphate.

(3) Two mL of the sample solution obtained in (2) responds to Qualitative Tests <1.09> for sulfate.

pH <2.54> Dissolve 0.1 g of Ecothiopate Iodide in 40 mL of water: the pH of this solution is between 3.0 and 5.0.

Melting point <2.60> 116 – 122°C

Purity (1) Clarity and color of solution—Dissolve 0.5 g of Ecothiopate Iodide in 5 mL of water: the solution is clear and colorless.

(2) Heavy metals <1.07>—To 1.0 g of Ecothiopate Iodide in a Kjeldahl flask add 5 mL of nitric acid and 2 mL of sulfuric acid, put a small funnel on the mouth of the flask, and heat carefully until white fumes are evolved. After cooling, add 2 mL of nitric acid, and heat. Repeat this procedure twice, add several 2-mL portions of hydrogen peroxide (30), and heat until the solution becomes colorless, and white fumes are evolved. After cooling, transfer the solution together with a small quantity of water to a Nessler tube, and add water to make about 20 mL. Adjust the solution with ammonia solution (28) and ammonia TS to a pH between 3.0 and 3.5, add water to make 50 mL, and use this solution as the test solution. Prepare the control solution as follows: proceed in the same manner as the preparation of the test solution, and add 2.0 mL of Standard Lead Solution and water to make 50 mL (not more than 20 ppm).

(3) Related substances—Dissolve 0.20 g of Ecothiopate Iodide in 10 mL of methanol, and use this solution as the sample solution. Pipet 3 mL of the sample solution, add methanol to make exactly 200 mL, and use this solution as the standard solution. Perform the test with these solutions as directed under Thin-layer Chromatography <2.03>. Spot 10 μ L each of the sample solution and standard solution on a plate of cellulose for thin-layer chromatography. Develop the plate with a mixture of 1-butanol, water and acetic acid (100) (4:2:1) to a distance of about 10 cm, and air-dry the plate. Spray evenly Dragendorff's TS for spraying on the plate: the spots other than the principal spot obtained from the sample solution are not more intense than the spot from the standard solution.

Loss on drying <2.41> Not more than 1.0% (1 g, in vacuum, phosphorus (V) oxide, 50°C, 3 hours).

Assay Weigh accurately about 0.125 g of Ecothiopate Iodide, and dissolve in water to make exactly 100 mL. Pipet 10 mL of of this solution, add 30 mL of water, then add exactly 10 mL of phosphate buffer solution (pH 12), stopper the container, and allow to stand at $25 \pm 3^\circ\text{C}$ for 20 minutes. To this solution add quickly 2 mL of acetic acid (100), and titrate <2.50> with 0.002 mol/L iodine VS (potentiometric titration). Perform the test in the same manner without phosphate buffer solution (pH 12), and make any necessary correction.

$$\begin{aligned} & \text{Each mL of 0.002 mol/L iodine VS} \\ & = 1.533 \text{ mg of } \text{C}_9\text{H}_{23}\text{INO}_3\text{PS} \end{aligned}$$

Containers and storage Containers—Tight containers.

Storage—Light-resistant, and not exceeding 0°C.

Edaravone

エダラボン

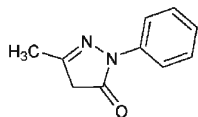
C₁₀H₁₀N₂O: 174.205-Methyl-2-phenyl-2,4-dihydro-3H-pyrazol-3-one
[89-25-8]

Edaravone, when dried, contains not less than 99.0% and not more than 101.0% of edaravone (C₁₀H₁₀N₂O).

Description Edaravone occurs as white to pale yellow-white, crystals or crystalline powder.

It is freely soluble in ethanol (99.5) and in acetic acid (100), and slightly soluble in water.

Identification (1) Determine the absorption spectrum of a solution of Edaravone (1 in 200,000) as directed under Ultraviolet-visible Spectrophotometry <2.24>, and compare the spectrum with the Reference Spectrum: both spectra exhibit similar intensities of absorption at the same wavelengths.

(2) Determine the infrared absorption spectrum of Edaravone, previously dried, as directed in the potassium bromide disk method under Infrared Spectrophotometry <2.25>, and compare the spectrum with the Reference Spectrum: both spectra exhibit similar intensities of absorption at the same wave numbers.

pH <2.54> The pH of a solution obtained by dissolving 20 mg of Edaravone in 20 mL of water is between 4.0 and 5.5.

Melting point <2.60> 127 – 131°C

Purity (1) Heavy metals <1.07>—Proceed with 2.0 g of Edaravone according to Method 2, and perform the test. Prepare the control solution with 2.0 mL of Standard Lead Solution (not more than 10 ppm).

(2) Related substances—Dissolve 50 mg of Edaravone in 25 mL of the mobile phase, and use this solution as the sample solution. Pipet 1 mL of the sample solution, and add the mobile phase to make exactly 50 mL. Pipet 1 mL of this solution, add the mobile phase to make exactly 20 mL, and use this solution as the standard solution. Perform the test with exactly 10 μL each of the sample solution and standard solution as directed under Liquid Chromatography <2.01> according to the following conditions. Determine each peak area by the automatic integration method: the area of the peak other than edaravone obtained from the sample solution is not larger than the peak area of edaravone from the standard solution.

Operating conditions—

Detector: An ultraviolet absorption photometer (wavelength: 240 nm).

Column: A stainless steel column 4.6 mm in inside diameter and 15 cm in length, packed with octadecylsilanized silica gel for liquid chromatography (5 μm in particle diameter).

Column temperature: A constant temperature of about 40°C.

Mobile phase: A mixture of water, methanol and acetic acid (100) (100:100:1).

Flow rate: Adjust so that the retention time of edaravone is about 4 minutes.

Time span of measurement: About 7 times as long as the retention time of edaravone, beginning after the solvent peak.

System suitability—

System performance: When the procedure is run with 10 μL of the standard solution under the above operating conditions, the number of theoretical plates and the symmetry factor of the peak of edaravone are not less than 1500 and not more than 1.4, respectively.

System repeatability: When the test is repeated 6 times with 10 μL of the standard solution under the above operating conditions, the relative standard deviation of the peak area of edaravone is not more than 2.0%.

Loss on drying <2.41> Not more than 0.1% (1 g, in vacuum, phosphorus (V) oxide, 3 hours).

Residue on ignition <2.44> Not more than 0.1% (1 g).

Assay Weigh accurately about 0.2 g of Edaravone, previously dried, dissolve in 40 mL of acetic acid (100), and titrate <2.50> with 0.1 mol/L perchloric acid VS (potentiometric titration). Perform a blank determination in the same manner, and make any necessary correction.

Each mL of 0.1 mol/L perchloric acid VS
= 17.42 mg of C₁₀H₁₀N₂O

Containers and storage Containers—Well-closed containers.

Edaravone Injection

エダラボン注射液

Edaravone Injection is an aqueous injection.

It contains not less than 95.0% and not more than 105.0% of the labeled amount of edaravone (C₁₀H₁₀N₂O: 174.20).

Method of preparation Prepare as directed under Injections, with Edaravone.

Description Edaravone Injection occurs as a clear and colorless liquid.

Identification To a volume of Edaravone Injection, equivalent to 1.5 mg of Edaravone, add water to make 50 mL. To 5 mL of this solution add water to make 25 mL. Determine the absorption spectrum of this solution as directed under Ultraviolet-visible Spectrophotometry <2.24>: it exhibits a maximum between 238 nm and 242 nm.

pH Being specified separately when the drug is granted approval based on the Law.

Purity Related substance—(i) Perform the following test 1). For preparations to which the test 2) can be applied, the test 2) may be performed instead of 1).

1) To a suitable amount of Edaravone Injection add the mobile phase so that each mL contains 0.3 mg of edaravone (C₁₀H₁₀N₂O), and use this solution as the sample solution. Pipet 1 mL of the sample solution, and add the mobile phase to make exactly 50 mL. Pipet 1 mL of this solution, add the mobile phase to make exactly 20 mL, and use this solution as the standard solution. Perform the test with exactly 50 μL each of the sample solution and standard solution as directed under Liquid Chromatography <2.01> according to the following conditions. Determine each peak area by the automatic integration method: the area of the peak other than

edaravone obtained from the sample solution is not larger than 2 times the peak area of edaravone from the standard solution.

Operating conditions—

Detector, column, column temperature, mobile phase, and flow rate: Proceed as directed in the operating conditions in the Purity (2) under Edaravone.

Time span of measurement: About 7 times as long as the retention time of edaravone, beginning after the peak of edaravone.

System suitability—

System performance: When the procedure is run with 50 μL of the standard solution under the above operating conditions, the number of theoretical plates and the symmetry factor of the peak of edaravone are not less than 1500 and not more than 1.4, respectively.

System repeatability: When the test is repeated 6 times with 50 μL of the standard solution under the above operating conditions, the relative standard deviation of the peak area of edaravone is not more than 2.0%.

2) Use Edaravone Injection as the sample solution. Pipet 1 mL of the sample solution, and add the mobile phase to make exactly 50 mL. Pipet 1 mL of this solution, add the mobile phase to make exactly 20 mL, and use this solution as the standard solution. Perform the test with exactly 10 μL each of the sample solution and standard solution as directed under Liquid Chromatography <2.01> according to the following conditions. Determine each peak area by the automatic integration method: the area of the peak other than edaravone obtained from the sample solution is not larger than 2 times the peak area of edaravone from the standard solution.

Operating conditions—

Detector, column, column temperature, mobile phase, and flow rate: Proceed as directed in the operating conditions in the Purity (2) under Edaravone.

Time span of measurement: About 7 times as long as the retention time of edaravone, beginning after the peak of edaravone.

System suitability—

System performance: When the procedure is run with 10 μL of the standard solution under the above operating conditions, the number of theoretical plates and the symmetry factor of the peak of edaravone are not less than 1500 and not more than 1.4, respectively.

System repeatability: When the test is repeated 6 times with 10 μL of the standard solution under the above operating conditions, the relative standard deviation of the peak area of edaravone is not more than 2.0%.

(ii) Perform the following test 1). For preparations to which the test 2) can be applied, the test 2) may be performed instead of 1).

1) To a suitable amount of Edaravone Injection add the mobile phase so that each mL contains 0.3 mg of edaravone ($\text{C}_{10}\text{H}_{10}\text{N}_2\text{O}$), and use this solution as the sample solution. Pipet 1 mL of the sample solution, and add the mobile phase to make exactly 50 mL. Pipet 1 mL of this solution, add the mobile phase to make exactly 20 mL, and use this solution as the standard solution. Perform the test with exactly 50 μL each of the sample solution and standard solution as directed under Liquid Chromatography <2.01> according to the following conditions. Determine each peak area by the automatic integration method: the area of the peak, having the relative retention time of about 0.3 to edaravone, obtained from the sample solution is not larger than 4 times the peak area of edaravone from the standard solution, the area of the peak, having the relative retention time of about 0.4, ob-

tained from the sample solution is not larger than the peak area of edaravone from the standard solution, and the area of the peak other than edaravone and the peaks mentioned above from the sample solution is not larger than 2 times the peak area of edaravone from the standard solution.

Operating conditions—

Detector, column, and mobile phase: Proceed as directed in the operating conditions in the Assay 1).

Column temperature: A constant temperature of about 40°C.

Flow rate: Adjust so that the retention time of edaravone is about 11 minutes.

Time span of measurement: About 2.5 times as long as the retention time of edaravone, beginning after the solvent peak.

System suitability—

System performance: When the procedure is run with 50 μL of the standard solution under the above operating conditions, the number of theoretical plates and the symmetry factor of the peak of edaravone are not less than 2000 and not more than 1.4, respectively.

System repeatability: When the test is repeated 6 times with 50 μL of the standard solution under the above operating conditions, the relative standard deviation of the peak area of edaravone is not more than 2.0%.

2) Use Edaravone Injection as the sample solution. Pipet 1 mL of the sample solution, and add the mobile phase to make exactly 50 mL. Pipet 1 mL of this solution, add the mobile phase to make exactly 20 mL, and use this solution as the standard solution. Perform the test with exactly 10 μL each of the sample solution and standard solution as directed under Liquid Chromatography <2.01> according to the following conditions. Determine each peak area by the automatic integration method: the area of the peak, having the relative retention time of about 0.3 to edaravone, obtained from the sample solution is not larger than 4 times the peak area of edaravone from the standard solution, the area of the peak, having the relative retention time of about 0.4, from the sample solution is not larger than the peak area of edaravone from the standard solution, and the area of the peak other than edaravone and the peaks mentioned above from the sample solution is not larger than 2 times the peak area of edaravone from the standard solution.

Operating conditions—

Detector, column, and mobile phase: Proceed as directed in the operating conditions in the Assay 1).

Column temperature: A constant temperature of about 40°C.

Flow rate: Adjust so that the retention time of edaravone is about 11 minutes.

Time span of measurement: About 2.5 times as long as the retention time of edaravone, beginning after the solvent peak.

System suitability—

System performance: When the procedure is run with 10 μL of the standard solution under the above operating conditions, the number of theoretical plates and the symmetry factor of the peak of edaravone are not less than 2000 and not more than 1.4, respectively.

System repeatability: When the test is repeated 6 times with 10 μL of the standard solution under the above operating conditions, the relative standard deviation of the peak area of edaravone is not more than 2.0%.

Bacterial endotoxins <4.01> Less than 5.0 EU/mg.

Extractable volume <6.05> It meets the requirement.

Foreign insoluble matter <6.06> Perform the test according to Method 1: it meets the requirement.

Insoluble particulate matter <6.07> It meets the requirement.

Sterility <4.06> Perform the test according to the Membrane filtration method: it meets the requirement.

Assay Perform the following test 1). For preparations to which the test 2) can be applied, the test 2) may be performed instead of 1).

1) To exactly V mL of Edaravone Injection add methanol to make exactly V' mL so that each mL contains about 0.3 mg of edaravone ($C_{10}H_{10}N_2O$). Pipet 2 mL of this solution, add exactly 10 mL of the internal standard solution, then add methanol to make 20 mL, and use this solution as the sample solution. Separately, weigh accurately about 30 mg of edaravone for assay, previously dried in vacuum using phosphorus (V) oxide as a desiccant for 3 hours, and dissolve in methanol to make exactly 100 mL. Pipet 2 mL of this solution, add exactly 10 mL of the internal standard solution, then add methanol to make 20 mL, and use this solution as the standard solution. Perform the test with 10 μ L each of the sample solution and standard solution as directed under Liquid Chromatography <2.01> according to the following conditions, and calculate the ratios, Q_T and Q_S , of the peak area of edaravone to that of the internal standard.

$$\begin{aligned} \text{Amount (mg) of edaravone (C}_{10}\text{H}_{10}\text{N}_2\text{O)} \\ = M_S \times Q_T/Q_S \times V'/V \times 1/100 \end{aligned}$$

M_S : Amount (mg) of edaravone for assay taken

Internal standard solution—A solution of ethyl aminobenzoate in methanol (1 in 2500).

Operating conditions—

Detector: An ultraviolet absorption photometer (wavelength: 240 nm).

Column: A stainless steel column 4.6 mm in inside diameter and 15 cm in length, packed with octadecylsilanized silica gel for liquid chromatography (5 μ m in particle diameter).

Column temperature: A constant temperature of about 50°C.

Mobile phase: A mixture of diluted dilute acetic acid (1 in 100) and methanol (3:1), adjusted to pH 5.5 with diluted ammonia solution (28) (1 in 20).

Flow rate: Adjust so that the retention time of edaravone is about 8 minutes.

System suitability—

System performance: When the procedure is run with 10 μ L of the standard solution under the above operating conditions, edaravone and the internal standard are eluted in this order with the resolution between these peaks being not less than 7.

System repeatability: When the test is repeated 6 times with 10 μ L of the standard solution under the above operating conditions, the relative standard deviation of the ratio of the peak area of edaravone to that of the internal standard is not more than 1.0%.

2) To an exact volume of Edaravone Injection, equivalent to about 3 mg of edaravone ($C_{10}H_{10}N_2O$) add exactly 10 mL of the internal standard solution, add methanol to make 20 mL, and use this solution as the sample solution. Separately, weigh accurately about 75 mg of edaravone for assay, previously dried in vacuum using phosphorus (V) oxide as a desiccant for 3 hours, and dissolve in methanol to make exactly 50 mL. Pipet 2 mL of this solution, add exactly 10 mL of the internal standard solution, add methanol to make 20 mL, and use this solution as the standard solution. Perform

the test with 2 μ L each of the sample solution and standard solution as directed under Liquid Chromatography <2.01> according to the following conditions, and calculate the ratios, Q_T and Q_S , of the peak area of edaravone to that of the internal standard.

$$\begin{aligned} \text{Amount (mg) of edaravone (C}_{10}\text{H}_{10}\text{N}_2\text{O)} \\ = M_S \times Q_T/Q_S \times 1/25 \end{aligned}$$

M_S : Amount (mg) of edaravone for assay taken

Internal standard solution—A solution of ethyl aminobenzoate in methanol (1 in 500).

Operating conditions—

Proceed as directed in the operating conditions in the Assay 1).

System suitability—

System performance: When the procedure is run with 2 μ L of the standard solution under the above operating conditions, edaravone and the internal standard are eluted in this order with the resolution between these peaks being not less than 7.

System repeatability: When the test is repeated 6 times with 2 μ L of the standard solution under the above operating conditions, the relative standard deviation of the ratio of the peak area of edaravone to that of the internal standard is not more than 1.0%.

Containers and storage Containers—Hermetic containers. Plastic containers for aqueous injections may be used.

Edrophonium Chloride

エドロホニウム塩化物

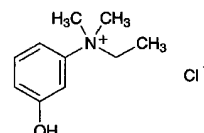

$C_{10}H_{16}ClNO$: 201.69

N-Ethyl-3-hydroxy-*N,N*-dimethylanilinium chloride [116-38-1]

Edrophonium Chloride, when dried, contains not less than 98.0% of edrophonium chloride ($C_{10}H_{16}ClNO$).

Description Edrophonium Chloride occurs as white, crystals or crystalline powder. It is odorless.

It is very soluble in water, freely soluble in ethanol (95) and in acetic acid (100), and practically insoluble in acetic anhydride and in diethyl ether.

It is hygroscopic.

It is gradually colored by light.

Identification (1) To 5 mL of a solution of Edrophonium Chloride (1 in 100) add 1 drop of iron (III) chloride TS: a light red-purple color develops.

(2) Determine the absorption spectrum of a solution of Edrophonium Chloride in 0.1 mol/L hydrochloric acid TS (1 in 20,000) as directed under Ultraviolet-visible Spectrophotometry <2.24>, and compare the spectrum with the Reference Spectrum or the spectrum of a solution of Edrophonium Chloride RS prepared in the same manner as the sample solution: both spectra exhibit similar intensities of absorption at the same wavelengths.

(3) A solution of Edrophonium Chloride (1 in 50) responds to Qualitative Tests <1.09> for chloride.

pH <2.54> Dissolve 1.0 g of Edrophonium Chloride in 10 mL of water: the pH of this solution is between 3.5 and 5.0.

Melting point <2.60> 166 – 171°C (with decomposition).

Purity (1) Clarity and color of solution—Dissolve 1.0 g of Edrophonium Chloride in 10 mL of water: the solution is clear and colorless.

(2) Heavy metals <1.07>—Proceed with 1.0 g of Edrophonium Chloride according to Method 1, and perform the test. Prepare the control solution with 2.0 mL of Standard Lead Solution (not more than 20 ppm).

(3) Arsenic <1.11>—Prepare the test solution with 1.0 g of Edrophonium Chloride according to Method 1, and perform the test (not more than 2 ppm).

(4) Related substances—Dissolve 0.50 g of Edrophonium Chloride in 10 mL of ethanol (95), and use this solution as the sample solution. Pipet 1 mL of the sample solution, and add ethanol (95) to make exactly 100 mL. Pipet 3 mL of this solution, add ethanol (95) to make exactly 10 mL, and use this solution as the standard solution. Perform the test with these solutions as directed under Thin-layer Chromatography <2.03>. Spot 10 μ L each of the sample solution and standard solution on a plate of silica gel with fluorescent indicator for thin-layer chromatography. Develop the plate with a mixture of methanol, chloroform and ammonia solution (28) (16:4:1) to a distance of about 10 cm, and air-dry the plate. Examine under ultraviolet light (main wavelength: 254 nm): the spots other than the principal spot obtained from the sample solution are not more intense than the spot from the standard solution.

Loss on drying <2.41> Not more than 0.20% (1 g, in vacuum, phosphorus (V) oxide, 3 hours).

Residue on ignition <2.44> Not more than 0.1% (1 g).

Assay Weigh accurately about 0.2 g of Edrophonium Chloride, previously dried, and dissolve in 100 mL of a mixture of acetic anhydride and acetic acid (100) (7:3). Titrate <2.50> with 0.1 mol/L perchloric acid VS (potentiometric titration). Perform a blank determination in the same manner, and make any necessary correction.

$$\begin{aligned} \text{Each mL of 0.1 mol/L perchloric acid VS} \\ = 20.17 \text{ mg of } C_{10}H_{16}ClNO \end{aligned}$$

Containers and storage Containers—Tight containers.
Storage—Light-resistant.

Edrophonium Chloride Injection

エドロホニウム塩化物注射液

Edrophonium Chloride Injection is an aqueous injection.

It contains not less than 95.0% and not more than 105.0% of the labeled amount of edrophonium chloride ($C_{10}H_{16}ClNO$: 201.69).

Method of preparation Prepare as directed under Injections, with Edrophonium Chloride.

Description Edrophonium Chloride Injection is a clear and colorless liquid.

Identification (1) To a volume of Edrophonium Chloride Injection, equivalent to 0.04 g of Edrophonium Chloride, add 4 mL of barium nitrate TS, shake, and filter. Proceed with the filtrate as directed in the Identification (1) under

Edrophonium Chloride.

(2) Determine the absorption spectrum of the sample solution obtained in the Assay as directed under Ultraviolet-visible Spectrophotometry <2.24>: it exhibits a maximum between 272 nm and 276 nm.

pH <2.54> 6.5 – 8.0

Bacterial endotoxins <4.01> Less than 15 EU/mg.

Extractable volume <6.05> It meets the requirement.

Foreign insoluble matter <6.06> Perform the test according to Method 1: it meets the requirement.

Insoluble particulate matter <6.07> It meets the requirement.

Sterility <4.06> Perform the test according to the Membrane filtration method: it meets the requirement.

Assay Conduct this procedure without exposure to light, using light-resistant vessels. Measure exactly a volume of Edrophonium Chloride Injection, equivalent to about 50 mg of edrophonium chloride ($C_{10}H_{16}ClNO$), place in a chromatographic column prepared by pouring 10 mL of weakly basic DEAE-bridged dextran anion exchanger (Cl type) (50 to 150 μ m in particle diameter) into a chromatographic tube about 2 cm in inside diameter and about 10 cm in length, add 25 mL of water, and elute at the flow rate of 1 to 2 mL per minute. Wash the column with two 25-mL portions of water at the flow rate of 1 to 2 mL per minute. Combine the washings with above effluent solutions, and add water to make exactly 100 mL. Measure exactly 10 mL of this solution, and add 10 mL of phosphate buffer solution (pH 8.0) and 5 g of sodium chloride. Wash this solution with four 20-mL portions of a mixture of diethyl ether and hexane (1:1), collect the water layer, add 0.1 mol/L hydrochloric acid TS to make exactly 100 mL, and use this solution as the sample solution. Separately, weigh accurately about 50 mg of Edrophonium Chloride RS, previously dried in a desiccator (in vacuum, phosphorus (V) oxide) for 3 hours, and dissolve in water to make exactly 100 mL. Measure exactly 10 mL of this solution, and prepare the standard solution in the same manner as the sample solution. Determine the absorbances, A_T and A_S , of the sample solution and standard solution at 273 nm as directed under Ultraviolet-visible Spectrophotometry <2.24>.

$$\begin{aligned} \text{Amount (mg) of edrophonium chloride } (C_{10}H_{16}ClNO) \\ = M_S \times A_T / A_S \end{aligned}$$

M_S : Amount (mg) of Edrophonium Chloride RS taken

Containers and storage Containers—Hermetic containers, and colored containers may be used.

Storage—Light-resistant.

Elcatonin

エルカトニン

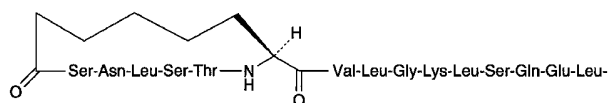

His-Lys-Leu-Gln-Thr-Tyr-Pro-Arg-Thr-Asp-Val-Gly-Ala-Gly-Thr-Pro-NH₂

C₁₄₈H₂₄₄N₄₂O₄₇; 3363.77
[60731-46-6]

Elcatonin contains not less than 5000 Elcatonin Units and not more than 7000 Elcatonin Units per mg of peptide, calculated on the anhydrous and residual acetic acid-free basis.

Description Elcatonin is a white powder.

It is very soluble in water, freely soluble in ethanol (95), and practically insoluble in acetonitrile.

It is hygroscopic.

The pH of a solution of Elcatonin (1 in 500) is between 4.5 and 7.0.

Identification Dissolve 5 mg of Elcatonin in 5 mL of water. Determine the absorption spectrum of the solution as directed under Ultraviolet-visible Spectrophotometry <2.24>, and compare the spectrum with the Reference Spectrum: both spectra exhibit similar intensities of absorption at the same wavelengths.

Constituent amino acids Put about 1 mg of Elcatonin in a test tube for hydrolysis, add phenol-hydrochloric acid TS to dissolve, replace the air inside with Nitrogen, seal the tube under reduced pressure, and heat at 110 ± 2°C for 24 hours. After cooling, open the tube, evaporate the hydrolyzate to dryness under reduced pressure, dissolve the residue in about 1 mL of 0.02 mol/L hydrochloric acid TS, and use this solution as the sample solution. Separately, weigh exactly 1.33 mg of L-aspartic acid, 1.19 mg of L-threonine, 1.05 mg of L-serine, 1.47 mg of L-glutamic acid, 1.15 mg of L-proline, 0.75 mg of glycine, 0.89 mg of L-alanine, 1.17 mg of L-valine, 1.89 mg of L-2-aminosuberic acid, 1.31 mg of L-leucine, 1.81 mg of L-tyrosine, 1.83 mg of L-lysine hydrochloride, 2.10 mg of L-histidine hydrochloride monohydrate and 2.11 mg of L-arginine hydrochloride, dissolve them in 0.02 mol/L hydrochloric acid TS to make exactly 50 mL, and use this solution as the standard solution. Perform the test with exactly 10 μL each of the sample solution and standard solution as directed under Liquid Chromatography <2.01> according to the following conditions: 14 peaks of amino acids appear on the chromatogram obtained from the sample solution, and their respective molar ratios against alanine are 1.7–2.2 for aspartic acid, 3.5–4.2 for threonine, 2.4–3.0 for serine, 2.7–3.2 for glutamic acid, 1.7–2.2 for proline, 2.7–3.2 for glycine, 1.6–2.2 for valine, 0.8–1.2 for 2-aminosuberic acid, 4.5–5.2 for leucine, 0.7–1.2 for tyrosine, 1.7–2.2 for lysine, 0.8–1.2 for histidine and 0.7–1.2 for arginine.

Operating conditions—

Detector: A visible spectrophotometer (wavelength: 440 nm and 570 nm).

Column: A stainless steel column about 4 mm in inside diameter and about 8 cm in length, packed with strongly acidic ion-exchange resin for liquid chromatography composed with a sulfonated styrene-divinylbenzene copolymer (3 μm in particle diameter).

Column temperature: Varied between 50°C and 65°C.

Chemical reaction vessel temperature: A constant temperature of about 130°C.

Color developing time: About 1 minute.

Mobile phase: Buffer solutions A, B, C and D, with sodium ion concentrations of 0.10 mol/L, 0.135 mol/L, 1.26 mol/L and 0.20 mol/L, respectively. The ion concentration of the mobile phase is changed stepwise from 0.10 mol/L to 1.26 mol/L by using these buffer solutions.

Buffer solution:	Components of buffer solutions			
	A	B	C	D
Citric acid monohydrate	8.85 g	7.72 g	6.10 g	—
Trisodium citrate dihydrate	3.87 g	10.05 g	26.67 g	—
Sodium hydroxide	—	—	2.50 g	8.00 g
Sodium chloride	3.54 g	1.87 g	54.35 g	—
Ethanol (95)	60.0 mL	—	—	60.0 mL
Thiodiglycol	5.0 mL	5.0 mL	—	—
Purified water	a sufficient amount	a sufficient amount	a sufficient amount	a sufficient amount
Total amount	1000 mL	1000 mL	1000 mL	1000 mL

Reaction reagent: Mix 407 g of lithium acetate dihydrate, 245 mL of acetic acid (100) and 801 mL of 1-methoxy-2-propanol, add water to make 2000 mL, stir for about 20 minutes while passing Nitrogen, and use this solution as solution A. Separately, to 1957 mL of 1-methoxy-2-propanol add 77 g of ninhydrin and 0.134 g of sodium borohydride, stir for about 20 minutes while passing Nitrogen, and use this solution as solution B. Mix solution A and solution B before use.

Flow rate of mobile phase: Adjust so that the retention time of arginine is about 75 minutes.

Flow rate of reaction reagent: About 0.2 mL per minute.

Selection of column: Proceed with 10 μL of the standard solution under the above operating conditions. Use a column from which aspartic acid, threonine, serine, glutamic acid, proline, glycine, alanine, valine, 2-aminosuberic acid, leucine, tyrosine, lysine, histidine and arginine are eluted in this order, with complete separation of each peak.

Purity (1) Acetic acid—Weigh accurately 3–6 mg of Elcatonin quickly under conditions of 25 ± 2°C and 50 ± 5% relative humidity, add exactly 1 mL of the internal standard solution to dissolve it, and use this solution as the sample solution. Separately, weigh accurately about 0.5 g of acetic acid (100), and add the internal standard solution to make exactly 100 mL. Pipet 5 mL of this solution, add the internal standard solution to make exactly 100 mL, and use this solution as the standard solution. Perform the test with 20 μL each of the sample solution and standard solution as directed under Liquid Chromatography <2.01> according to the following conditions, and calculate the ratios, Q_T and Q_S , of the peak area of acetic acid to that of the internal standard: the amount of acetic acid is not more than 7.0%.

$$\begin{aligned} &\text{Amount (\% of acetic acid (CH}_3\text{COOH))} \\ &= M_{ST}/M_{SA} \times Q_T/Q_S \times 50 \end{aligned}$$

M_{ST} : Amount (g) of acetic acid (100) taken

M_{SA} : Amount (mg) of Elcatonin taken

Internal standard solution—A solution of citric acid monohydrate (1 in 4000).

Operating conditions—

Detector: An ultraviolet absorption photometer (wavelength: 210 nm).

Column: A stainless steel column about 4 mm in inside diameter and about 15 cm in length, packed with octadecylsilanized silica gel for liquid chromatography (5 μ m in particle diameter).

Column temperature: A constant temperature of about 25°C.

Mobile phase: Dissolve 13.2 g of diammonium hydrogen phosphate in 900 mL of water, add phosphoric acid to adjust the pH to 2.5, and add water to make 1000 mL.

Flow rate: Adjust so that the retention time of acetic acid is about 4 minutes.

Selection of column: Proceed with 20 μ L of the standard solution under the above operating conditions. Use a column from which acetic acid and citric acid are eluted in this order with the resolution between their peaks being not less than 2.0.

(2) Related substances—Dissolve 1.0 mg of Elcatonin in 1 mL of a mixture of trifluoroacetic acid TS and acetonitrile (2:1), and use this solution as the sample solution. Take exactly 0.3 mL of the sample solution, add a mixture of trifluoroacetic acid TS and acetonitrile (2:1) to make exactly 10 mL, and use this solution as the standard solution. Perform the test with exactly 10 μ L each of the sample solution and standard solution as directed under Liquid Chromatography <2.01> according to the following conditions, and determine each peak area by the automatic integration method: each peak area other than elcatonin obtained from the sample solution is not larger than 1/3 times the peak area of elcatonin from the standard solution, and the total of the peak areas other than elcatonin is not larger than the peak area of elcatonin from the standard solution.

Operating conditions—

Detector: An ultraviolet absorption photometer (wavelength: 225 nm).

Column: A stainless steel column about 4 mm in inside diameter and about 15 cm in length, packed with octadecylsilanized silica gel for liquid chromatography (5 μ m in particle diameter).

Column temperature: A constant temperature of about 40°C.

Mobile phase: A mixture of trifluoroacetic acid TS and acetonitrile (change the ratio linearly from 85:15 to 55:45 in 30 minutes).

Flow rate: Adjust so that the retention time of elcatonin is about 25 minutes.

Selection of column: Dissolve 2 mg of Elcatonin in 200 μ L of trypsin TS for test of elcatonin, warm at 37°C for 1 hour, then add 1 drop of acetic acid (100), and heat at 95°C for 1 minute. To 10 μ L of this solution add 50 μ L of the sample solution, and mix. Proceed with 10 μ L of this solution under the above operating conditions, and calculate the resolution. Use a column such that the resolution between the peak of elcatonin and the peak which appears immediately before the peak of elcatonin is not less than 2.0, and the retention time of elcatonin is about 25 minutes.

Detection sensitivity: Adjust the detection sensitivity so that the peak height of elcatonin from 10 μ L of the standard solution is between 50 mm and 200 mm.

Time span of measurement: Continue measurement until the regularly changing base-line of the chromatogram disappears, beginning after the solvent peak.

Water <2.48> Weigh accurately 1–3 mg of Elcatonin quickly under conditions of 25 \pm 2°C and 50 \pm 5% relative

humidity, and perform the test as directed in Coulometric titration: not more than 8.0%.

Nitrogen content Weigh accurately 0.015–0.02 g of Elcatonin quickly under conditions of 25 \pm 2°C and 50 \pm 5% relative humidity, and perform the test as directed under Nitrogen Determination <1.08>: it contains not less than 16.1% and not more than 18.7% of nitrogen (N: 14.01) in the peptide, calculated on the anhydrous and residual acetic acid-free basis.

Assay (i) Animals: Select healthy male Sprague-Dawley rats each weighing between 90 g and 110 g. Keep the rats for not less than 3 days before use, providing an appropriate uniform diet and water.

(ii) Diluent for elcatonin: Dissolve 2.72 g of sodium acetate trihydrate in water to make 200 mL, add 0.2 g of bovine serum albumin, and adjust the pH to 6.0 with acetic acid (100). Prepare before use.

(iii) Standard solution: Dissolve Elcatonin RS in the diluent for elcatonin to make two standard solutions, one to contain exactly 0.075 Unit in each mL which is designated as the high-dose standard solution, S_H , and the other to contain exactly 0.0375 Unit in each mL which is designated as the low-dose standard solution, S_L .

(iv) Sample solution: Weigh accurately 0.5–2.0 mg of Elcatonin quickly under conditions of 25 \pm 2°C and 50 \pm 5% relative humidity, and dissolve in the diluent for elcatonin to make two sample solutions, the high-dose sample solution, T_H , which contains the Units per mL equivalent to S_H and the low-dose sample solution, T_L , which contains the Units per mL equivalent to S_L .

(v) Deproteinizing solution for elcatonin: Dissolve 160 g of trichloroacetic acid and 30.6 g of strontium chloride in water to make 3600 mL.

(vi) Procedure: Divide the animals into 4 equal groups of not less than 10 animals each. Withhold all food, but not water, for 18 to 24 hours before the injections, and withhold water during the assay until the final blood sample is taken. Handle the animals with care in order to avoid undue excitement.

Inject exactly 0.2 mL each of the standard solutions and the sample solutions into the tail vein of each animal as indicated in the following design:

First group	S_H	Third group	T_H
Second group	S_L	Fourth group	T_L

At 1 hour after the injection, take a sufficient blood sample to perform the test from the carotid artery and vein of each animal under ether anesthesia, centrifuge the blood samples to separate serum, and determine the serum calcium according to the following (vii).

(vii) Serum calcium determination: Take exactly 0.3 mL of the serum, add the deproteinizing solution for elcatonin to make exactly 3 mL, mix well, centrifuge, and use the supernatant liquid as the sample solution for calcium determination. Separately, pipet 1 mL of Standard Calcium Solution for Atomic Absorption Spectrophotometry, and add a solution of sodium chloride (17 in 2000) to make exactly 10 mL. Pipet 5 mL of this solution, add the deproteinizing solution for elcatonin to make exactly 50 mL, and use this solution as the standard solution for calcium determination. Determine the absorbances, A_T and A_S , of the sample solution and standard solution as directed under Atomic Absorption Spectrophotometry <2.23> according to the following conditions. Determine the absorbance, A_0 , of a solution obtained in the same manner used for preparation of the standard solution, but with 1 mL of water instead of the standard solution.

Amount (mg) of calcium (Ca) in 100 mL of the serum
 $= 0.01 \times (A_T - A_0)/(A_S - A_0) \times 10 \times 100$

Gas: Combustible gas—Acetylene.

Supporting gas—Air.

Lamp: Calcium hollow-cathode lamp.

Wavelength: 422.7 nm.

(viii) Calculation: Amounts of calcium in 100 mL of the serum obtained with S_H , S_L , T_H and T_L in (vii) are symbolized as y_1 , y_2 , y_3 and y_4 , respectively. Sum up individual y_1 , y_2 , y_3 and y_4 to obtain Y_1 , Y_2 , Y_3 and Y_4 , respectively.

Units per mg of peptide, calculated on the anhydrous and residual acetic acid-free basis

$= \text{antilog } M \times \text{units per mL of } S_H \times b/a$

$M = 0.3010 \times Y_a/Y_b$

$Y_a = -Y_1 - Y_2 + Y_3 + Y_4$

$Y_b = Y_1 - Y_2 + Y_3 - Y_4$

a : Amount (mg) of Elcatonin taken

$\times [100 - \{\text{water content (\%)} + \text{acetic acid content (\%)}\}]/100]$

b : Total volume (mL) of the high-dose sample solution prepared by dissolving Elcatonin with diluent for elcatonin

F' computed by the following equation should be smaller than F shown in the table against n with which s^2 is calculated. Calculate L ($P = 0.95$) by use of the following equation: L should be not more than 0.20. If F' exceeds F , or if L exceeds 0.20, repeat the test, increasing the number of animals or arranging the assay conditions so that F' is not more than F and L is not more than 0.20.

$$F' = (-Y_1 + Y_2 + Y_3 - Y_4)^2/4fs^2$$

f : Number of the animals of each group

$$s^2 = \{\Sigma y^2 - (Y/f)\}/n$$

Σy^2 : The sum of squares of y_1 , y_2 , y_3 and y_4 in each group

$Y = Y_1^2 + Y_2^2 + Y_3^2 + Y_4^2$

$n = 4(f - 1)$

$$L = 2\sqrt{(C - 1)(CM^2 + 0.09062)}$$

$$C = Y_b^2/(Y_b^2 - 4fs^2t^2)$$

t^2 : Value shown in the following table against n used to calculate s^2

n	$t^2 = F$	n	$t^2 = F$	n	$t^2 = F$
1	161.45	13	4.667	25	4.242
2	18.51	14	4.600	26	4.225
3	10.129	15	4.543	27	4.210
4	7.709	16	4.494	28	4.196
5	6.608	17	4.451	29	4.183
6	5.987	18	4.414	30	4.171
7	5.591	19	4.381	40	4.085
8	5.318	20	4.351	60	4.001
9	5.117	21	4.325	120	3.920
10	4.965	22	4.301	∞	3.841
11	4.844	23	4.279		
12	4.747	24	4.260		

Containers and storage Containers—Tight containers.

Storage—Not exceeding 8°C.

Emedastine Fumarate

エメダスチンフマル酸塩

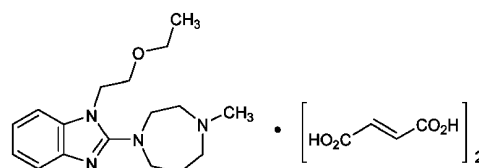

$C_{17}H_{26}N_4O \cdot 2C_4H_4O_4$; 534.56

1-(2-Ethoxyethyl)-2-(4-methyl-1,4-diazepan-1-yl)-
1*H*-benzimidazole difumarate
[87233-62-3]

Emedastine Fumarate, when dried, contains not less than 98.5% and not more than 101.0% of emedastine fumarate ($C_{17}H_{26}N_4O \cdot 2C_4H_4O_4$).

Description Emedastine Fumarate occurs as a white to pale yellow crystalline powder.

It is freely soluble in water, soluble in methanol, sparingly soluble in ethanol (99.5), and slightly soluble in acetic acid (100).

It shows crystal polymorphism.

Identification (1) Dissolve 10 mg of Emedastine Fumarate in 10 mL of water. To 2 mL of this solution add 1 mol/L hydrochloric acid TS to make 100 mL. Determine the absorption spectrum of this solution as directed under Ultraviolet-visible Spectrophotometry <2.24>, and compare the spectrum with the Reference Spectrum: both spectra exhibit similar intensities of absorption at the same wavelengths.

(2) Determine the infrared absorption spectrum of Emedastine Fumarate as directed in the paste method under Infrared Spectrophotometry <2.25>, and compare the spectrum with the Reference Spectrum: both spectra exhibit similar intensities of absorption at the same wave numbers.

(3) Dissolve 30 mg of Emedastine Fumarate in 5 mL of methanol, and use this solution as the sample solution. Separately, dissolve 10 mg of fumaric acid for thin-layer chromatography in 5 mL of methanol, and use this solution as the standard solution. Perform the test with these solutions as directed under Thin-layer Chromatography <2.03>. Spot 5 μ L each of the sample solution and standard solution on a plate of silica gel with fluorescent indicator for thin-layer chromatography. Develop the plate with a mixture of isopropyl ether, formic acid and water (90:7:3) to a distance of about 10 cm, and air-dry the plate. Examine under ultraviolet light (main wavelength: 254 nm): the spots other than the spot on the starting point obtained from the sample solution and the spot from the standard solution show the same R_f value.

Melting point <2.60> 149 – 152°C

Purity (1) Heavy metals <1.07>—Proceed with 2.0 g of Emedastine Fumarate according to Method 4, and perform the test. Prepare the control solution with 2.0 mL of Standard Lead Solution (not more than 10 ppm).

(2) Related substances—Dissolve 10 mg of Emedastine Fumarate in 10 mL of the mobile phase, and use this solution as the sample solution. Pipet 1 mL of the sample solution, and add the mobile phase to make exactly 100 mL. Pipet 1 mL of this solution, add the mobile phase to make exactly 10 mL, and use this solution as the standard solution. Perform the test with exactly 10 μ L each of the sample solu-

tion and standard solution as directed under Liquid Chromatography <2.01> according to the following conditions. Determine each peak area by the automatic integration method: the area of the peak other than emedastine and fumaric acid obtained from the sample solution is not larger than the peak area of emedastine from the standard solution.

Operating conditions—

Detector: An ultraviolet absorption photometer (wavelength: 280 nm).

Column: A stainless steel column 6.0 mm in inside diameter and 15 cm in length, packed with octadecylsilanized silica gel for liquid chromatography (5 μm in particle diameter).

Column temperature: A constant temperature of about 40°C.

Mobile phase: Dissolve 3.9 g of sodium dihydrogen phosphate dihydrate and 2.5 g of sodium lauryl sulfate in 1000 mL of water, and adjust to pH 2.4 with phosphoric acid. To 550 mL of this solution add 450 mL of acetonitrile.

Flow rate: Adjust so that the retention time of emedastine is about 18 minutes.

Time span of measurement: About 2 times as long as the retention time of emedastine, beginning after the solvent peak.

System suitability—

System performance: When the procedure is run with 10 μL of the standard solution under the above operating conditions, the number of theoretical plates and the symmetry factor of the peak of emedastine are not less than 10,000 and not more than 1.2, respectively.

System repeatability: When the test is repeated 6 times with 10 μL of the standard solution under the above operating conditions, the relative standard deviation of the peak area of emedastine is not more than 2.0%.

Loss on drying <2.41> Not more than 0.5% (0.5 g, 105°C, 3 hours).

Residue on ignition <2.44> Not more than 0.1% (1 g).

Assay Weigh accurately about 0.2 g of Emedastine Fumarate, previously dried, dissolve in 80 mL of acetic acid (100), and titrate <2.50> with 0.1 mol/L perchloric acid VS (potentiometric titration). Perform a blank determination in the same manner, and make any necessary correction.

$$\begin{aligned} \text{Each mL of 0.1 mol/L perchloric acid VS} \\ = 26.73 \text{ mg of } C_{17}H_{26}N_4O_2 \cdot C_4H_4O_4 \end{aligned}$$

Containers and storage Containers—Tight containers.

Emedastine Fumarate Extended-release Capsules

エメダスチンフマル酸塩徐放カプセル

Emedastine Fumarate Extended-release Capsules contain not less than 95.0% and not more than 105.0% of the labeled amount of emedastine fumarate ($C_{17}H_{26}N_4O_2 \cdot C_4H_4O_4$: 534.56).

Method of preparation Prepare as directed under Capsules, with Emedastine Fumarate.

Identification (1) Powder the content of Emedastine Fumarate Extended-release Capsules. To a portion of the powder, equivalent to 10 mg of Emedastine Fumarate, add 10 mL of water, shake thoroughly, and filter. Spot 1 drop of the filtrate on a filter paper, and spray Dragendorff's TS for

spraying on the filter: the spot shows an orange color.

(2) To 2 mL of the filtrate obtained in (1) add 1 mol/L hydrochloric acid TS to make 100 mL. Determine the absorption spectrum of this solution as directed under Ultraviolet-visible Spectrophotometry <2.24>: it exhibits maxima between 278 nm and 282 nm, and between 284 nm and 288 nm.

Uniformity of dosage units <6.02> Perform the test according to the following method: it meets the requirement of the Content uniformity test.

To 1 tablet of Emedastine Fumarate Extended-release Capsules add 40 mL of the mobile phase, sonicate for 30 minutes while occasional vigorous shaking, and add the mobile phase to make exactly V mL so that each mL contains about 20 μg of emedastine fumarate ($C_{17}H_{26}N_4O_2 \cdot C_4H_4O_4$). Centrifuge this solution, pipet 10 mL of the supernatant liquid, add exactly 5 mL of the internal standard solution, and use this solution as the sample solution. Then, proceed as directed in the Assay.

$$\begin{aligned} \text{Amount (mg) of emedastine fumarate} \\ (C_{17}H_{26}N_4O_2 \cdot C_4H_4O_4) \\ = M_S \times Q_T / Q_S \times V / 1000 \end{aligned}$$

M_S : Amount (mg) of emedastine fumarate for assay taken

Internal standard solution—A solution of 4-methylbenzophenone in the mobile phase (1 in 40,000).

Dissolution Being specified separately when the drug is granted approval based on the Law.

Assay Weigh accurately the content of not less than 20 Emedastine Fumarate Extended-release Capsules, and powder. Weigh accurately a portion of the powder, equivalent to about 2 mg of emedastine fumarate ($C_{17}H_{26}N_4O_2 \cdot C_4H_4O_4$), add 10 mL of the mobile phase, sonicate for 30 minutes while occasional vigorous shaking, and add the mobile phase to make exactly 100 mL. Centrifuge this solution, pipet 10 mL of the supernatant liquid, add exactly 5 mL of the internal standard solution, and use this solution as the sample solution. Separately, weigh accurately about 20 mg of emedastine fumarate for assay, previously dried at 105°C for 3 hours, and dissolve in the mobile phase to make 100 mL. Pipet 5 mL of this solution, and add the mobile phase to make exactly 50 mL. Then, pipet 10 mL of this solution, add exactly 5 mL of the internal standard solution, and use this solution as the standard solution. Perform the test with 10 μL each of the sample solution and standard solution as directed under Liquid Chromatography <2.01>, according to the following conditions, and calculate the ratios, Q_T and Q_S , of the peak area of emedastine to that of the internal standard.

$$\begin{aligned} \text{Amount (mg) of emedastine fumarate} \\ (C_{17}H_{26}N_4O_2 \cdot C_4H_4O_4) \\ = M_S \times Q_T / Q_S \times 1 / 10 \end{aligned}$$

M_S : Amount (mg) of emedastine fumarate for assay taken

Internal standard solution—A solution of 4-methylbenzophenone in the mobile phase (1 in 40,000).

Operating conditions—

Detector: An ultraviolet absorption photometer (wavelength: 280 nm).

Column: A stainless steel column 4.6 mm in inside diameter and 15 cm in length, packed with octadecylsilanized silica gel for liquid chromatography (5 μm in particle diameter).

Column temperature: A constant temperature of about 40°C.

Mobile phase: Dissolve 3.9 g of sodium dihydrogen phos-

phate dihydrate and 2.5 g of sodium lauryl sulfate in 1000 mL of water, and adjust to pH 2.4 with phosphoric acid. To 500 mL of this solution add 500 mL of acetonitrile.

Flow rate: Adjust so that the retention time of emedastine is about 6 minutes.

System suitability—

System performance: When the procedure is run with 10 μ L of the standard solution under the above operating conditions, emedastine and the internal standard are eluted in this order with the resolution between these peaks being not less than 6.

System repeatability: When the test is repeated 6 times with 10 μ L of the standard solution under the above operating conditions, the relative standard deviation of the ratio of the peak area of emedastine to that of the internal standard is not more than 1.0%.

Containers and storage Containers—Tight containers.

Emorfazone

エモルファゾン

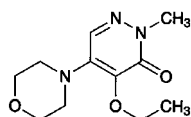

$C_{11}H_{17}N_3O_3$; 239.27

4-Ethoxy-2-methyl-5-(morpholin-4-yl)pyridazin-3(2H)-one
[38957-41-4]

Emorfazone, when dried, contains not less than 98.5% and not more than 101.0% of emorfazone ($C_{11}H_{17}N_3O_3$).

Description Emorfazone occurs as colorless crystals or a white to light yellow crystalline powder.

It is very soluble in ethanol (99.5), and freely soluble in water and in acetic anhydride.

It dissolves in 1 mol/L hydrochloric acid TS.

It gradually turns yellow and decomposes on exposure to light.

Identification (1) Dissolve 20 mg of Emorfazone in 2 mL of 1 mol/L hydrochloric acid TS, and add 5 drops of Reinecke's TS: light red floating matters are formed.

(2) Determine the absorption spectrum of a solution of Emorfazone (1 in 100,000) as directed under Ultraviolet-visible Spectrophotometry <2.24>, and compare the spectrum with the Reference Spectrum: both spectra exhibit similar intensities of absorption at the same wavelengths.

(3) Determine the infrared absorption spectrum of Emorfazone as directed in the potassium bromide disk method under Infrared Spectrophotometry <2.25>, and compare the spectrum with the Reference Spectrum: both spectra exhibit similar intensities of absorption at the same wave numbers.

Melting point <2.60> 89 – 92°C (after drying).

Purity (1) Chloride <1.03>—Perform the test with 1.0 g of Emorfazone. Prepare the control solution with 0.50 mL of 0.01 mol/L hydrochloric acid VS (not more than 0.018%).

(2) Heavy metals <1.07>—Proceed with 2.0 g of Emorfazone according to Method 2, and perform the test. Prepare the control solution with 2.0 mL of Standard Lead Solution (not more than 10 ppm).

(3) Arsenic <1.11>—Prepare the test solution with 2.0 g of Emorfazone according to Method 3, and perform the test (not more than 1 ppm).

(4) Related substances—Conduct this procedure using light-resistant vessels. Dissolve 0.5 g of Emorfazone in 50 mL of the mobile phase, and use this solution as the sample solution. Pipet 1 mL of the sample solution, add the mobile phase to make exactly 100 mL, and use this solution as the standard solution. Perform the test with exactly 20 μ L each of the sample solution and standard solution as directed under Liquid Chromatography <2.01> according to the following conditions, and determine each peak area by the automatic integration method: each peak area other than emorfazone obtained from the sample solution is not larger than 1/10 times the peak area of emorfazone from the standard solution, and the total area of the peaks other than emorfazone from the sample solution is not larger than 1/2 times the peak area of emorfazone from the standard solution.

Operating conditions—

Detector: An ultraviolet absorption photometer (wavelength: 254 nm).

Column: A stainless steel column 4.6 mm in inside diameter and 15 cm in length, packed with octadecylsilanized silica gel for liquid chromatography (5 μ m in particle diameter).

Column temperature: A constant temperature of about 25°C.

Mobile phase: A mixture of water and methanol (11:10).

Flow rate: Adjust so that the retention time of emorfazone is about 5 minutes.

Time span of measurement: About 2.5 times as long as the retention time of emorfazone, beginning after the solvent peak.

System suitability—

Test for required detectability: Pipet 1 mL of the standard solution, add the mobile phase to make exactly 20 mL. Confirm that the peak area of emorfazone obtained with 20 μ L of this solution is equivalent to 3.5 to 6.5% of that with 20 μ L of the standard solution.

System performance: Dissolve 16 mg of Emorfazone and 30 mg of 2,4-dinitrophenylhydrazine in 100 mL of methanol. When the procedure is run with 20 μ L of this solution under the above operating conditions, emorfazone and 2,4-dinitrophenylhydrazine are eluted in this order with the resolution between these peaks being not less than 2.5.

System repeatability: When the test is repeated 6 times with 20 μ L of the standard solution under the above operating conditions, the relative standard deviation of the peak area of emorfazone is not more than 1.0%.

Loss on drying <2.41> Not more than 0.5% (1 g, in vacuum, 60°C, 4 hours).

Residue on ignition <2.44> Not more than 0.1% (1 g).

Assay Weigh accurately about 0.2 g of Emorfazone, previously dried, dissolve in 60 mL of acetic anhydride, and titrate <2.50> with 0.1 mol/L perchloric acid VS (potentiometric titration). Perform a blank determination in the same manner, and make any necessary correction.

Each mL of 0.1 mol/L perchloric acid VS
= 23.93 mg of $C_{11}H_{17}N_3O_3$

Containers and storage Containers—Tight containers.

Storage—Light-resistant.

Emorfazone Tablets

エモルファゾン錠

Emorfazone Tablets contain not less than 95.0% and not more than 105.0% of the labeled amount of emorfazone (C₁₁H₁₇N₃O₃; 239.27).

Method of preparation Prepare as directed under Tablets, with Emorfazone.

Identification To a quantity of powdered Emorfazone Tablets, equivalent to 0.1 g of Emorfazone, add 100 mL of water, shake well, and centrifuge. Filter the supernatant liquid, and to 1 mL of the filtrate add water to make 100 mL. Determine the absorption spectrum of this solution as directed under Ultraviolet-visible Spectrophotometry <2.24>: it exhibits maxima between 237 nm and 241 nm, and between 310 nm and 314 nm, and a shoulder between 288 nm and 298 nm.

Uniformity of dosage units <6.02> Perform the test according to the following method: it meets the requirement of the Content uniformity test.

To 1 tablet of Emorfazone Tablets add methanol to make exactly *V* mL so that each mL contains about 4 mg of emorfazone (C₁₁H₁₇N₃O₃), and shake well to disintegrate. Centrifuge this solution, pipet 2 mL of the supernatant liquid, add exactly 10 mL of the internal standard solution, add methanol to make 50 mL, and use this solution as the sample solution. Proceed as directed in the Assay.

$$\begin{aligned} \text{Amount (mg) of emorfazone (C}_{11}\text{H}_{17}\text{N}_3\text{O}_3) \\ = M_S \times Q_T/Q_S \times V/5 \end{aligned}$$

M_S: Amount (mg) of emorfazone for assay taken

Internal standard solution—A solution of 2,4-dinitrophenylhydrazine in methanol (3 in 2000). Prepare before use.

Dissolution <6.10> When the test is performed at 50 revolutions per minute according to the Paddle method, using 900 mL of water as the dissolution medium, the dissolution rate in 45 minutes of Emorfazone Tablets is not less than 80%.

Start the test with 1 tablet of Emorfazone Tablets, withdraw not less than 20 mL of the medium at the specified minute after starting the test, and filter through a membrane filter with a pore size not exceeding 0.45 μm. Discard not less than 10 mL of the first filtrate, pipet *V* mL of the subsequent filtrate, add water to make exactly *V'* mL so that each mL contains about 11 μg of emorfazone (C₁₁H₁₇N₃O₃), and use this solution as the sample solution. Separately, weigh accurately about 28 mg of emorfazone for assay, previously dried in vacuum at 60°C for 4 hours, and dissolve in water to make exactly 100 mL. Pipet 4 mL of this solution, add water to make exactly 100 mL, and use this solution as the standard solution. Determine the absorbances, *A_T* and *A_S*, of the sample solution and standard solution at 239 nm as directed under Ultraviolet-visible Spectrophotometry <2.24>.

Dissolution rate (%) with respect to the labeled amount of emorfazone (C₁₁H₁₇N₃O₃)

$$= M_S \times A_T/A_S \times V'/V \times 1/C \times 36$$

M_S: Amount (mg) of emorfazone for assay taken

C: Labeled amount (mg) of emorfazone (C₁₁H₁₇N₃O₃) in 1 tablet

Assay To 10 tablets of Emorfazone Tablets add 200 mL of methanol, shake well to disintegrate, add methanol to make

exactly 250 mL, and centrifuge. Pipet a volume of the supernatant liquid, equivalent to about 8 mg of emorfazone (C₁₁H₁₇N₃O₃), add exactly 10 mL of the internal standard solution, add methanol to make 50 mL, and use this solution as the sample solution. Separately, weigh accurately about 20 mg of emorfazone for assay, previously dried in vacuum at 60°C for 4 hours, and dissolve in methanol to make exactly 25 mL. Pipet 10 mL of this solution, add exactly 10 mL of the internal standard solution, add methanol to make 50 mL, and use this solution as the standard solution. Perform the test with 20 μL each of the sample solution and standard solution as directed under Liquid Chromatography <2.01> according to the following conditions, and calculate the ratios, *Q_T* and *Q_S*, of the peak area of emorfazone to that of the internal standard.

$$\begin{aligned} \text{Amount (mg) of emorfazone (C}_{11}\text{H}_{17}\text{N}_3\text{O}_3) \\ = M_S \times Q_T/Q_S \times 2/5 \end{aligned}$$

M_S: Amount (mg) of emorfazone for assay taken

Internal standard solution—A solution of 2,4-dinitrophenylhydrazine in methanol (3 in 2000). Prepare before use.

Operating conditions—

Detector: An ultraviolet absorption photometer (wavelength: 313 nm).

Column: A stainless steel column 4.6 mm in inside diameter and 15 cm in length, packed with octadecylsilanized silica gel for liquid chromatography (5 μm in particle diameter).

Column temperature: A constant temperature of about 25°C.

Mobile phase: A mixture of water and methanol (11:10).

Flow rate: Adjust so that the retention time of emorfazone is about 5 minutes.

System suitability—

System performance: When the procedure is run with 20 μL of the standard solution under the above operating conditions, emorfazone and the internal standard are eluted in this order with the resolution between these peaks being not less than 2.5.

System repeatability: When the test is repeated 6 times with 20 μL of the standard solution under the above operating conditions, the relative standard deviation of the ratio of the peak area of emorfazone to that of the internal standard is not more than 1.0%.

Containers and storage Containers—Tight containers.

Storage—Light-resistant.

Enalapril Maleate

エナラプリルマレイン酸塩

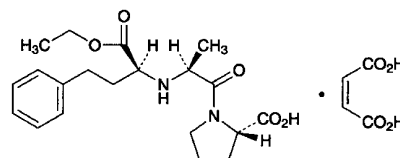

C₂₀H₂₈N₂O₅·C₄H₄O₄: 492.52

(2*S*)-1-[(2*S*)-2-[(1*S*)-1-Ethoxycarbonyl-3-phenylpropylamino]propanoyl]pyrrolidine-2-carboxylic acid monomaleate

[76095-16-4]

Enalapril Maleate, when dried, contains not less than 98.0% and not more than 102.0% of enalapril maleate (C₂₀H₂₈N₂O₅·C₄H₄O₄).

Description Enalapril Maleate occurs as white, crystals or crystalline powder.

It is freely soluble in methanol, sparingly soluble in water and in ethanol (99.5), and slightly soluble in acetonitrile.

Melting point: about 145°C (with decomposition).

Identification (1) Determine the infrared absorption spectra of Enalapril Maleate as directed in the potassium bromide disc method under Infrared Spectrophotometry <2.25>, and compare the spectrum with the Reference Spectrum or the spectrum of Enalapril Maleate RS: both spectra exhibit similar intensities of absorption at the same wave numbers.

(2) To 20 mg of Enalapril Maleate add 5 mL of 1 mol/L hydrochloric acid TS, shake, add 5 mL of diethyl ether, and shake for 5 minutes. Take 3 mL of the upper layer, distil off the diethyl ether on a water bath, add 5 mL of water to the residue with shaking, and add 1 drop of potassium permanganate TS: the red color of the test solution immediately disappears.

Optical rotation <2.49> $[\alpha]_D^{20}$: $-41.0 - -43.5^\circ$ (after drying, 0.25 g, methanol, 25 mL, 100 mm).

Purity (1) Heavy metals <1.07>—Proceed with 2.0 g of Enalapril Maleate according to Method 2, and perform the test. Prepare the control solution with 2.0 mL of Standard Lead Solution (not more than 10 ppm).

(2) Related substances—Dissolve 30 mg of Enalapril Maleate in 100 mL of a mixture of sodium dihydrogen phosphate TS (pH 2.5) and acetonitrile (19:1), and use this solution as the sample solution. Pipet 1 mL of the sample solution, add the mixture of sodium dihydrogen phosphate TS (pH 2.5) and acetonitrile (19:1) to make exactly 100 mL, and use this solution as the standard solution. Perform the test with exactly 50 μ L each of the sample solution and standard solution as directed under Liquid Chromatography <2.01> according to the following conditions, and determine each peak area of these solutions by the automatic integration method: the area of the peak other than maleic acid and enalapril obtained from the sample solution is not larger than the peak area of enalapril from the standard solution. Furthermore, the total area of the peaks other than maleic acid and enalapril from the sample solution is not larger than 2 times the peak area of enalapril from the standard solution.

Operating conditions—

Detector, column, column temperature, mobile phases, flowing of mobile phase, and flow rate: Proceed as directed in the operating conditions in the Assay.

Time span of measurement: About 2 times as long as the retention time of enalapril, beginning after the peak of maleic acid.

System suitability—

Test for required detectability: Pipet 1 mL of the standard solution, and add a mixture of sodium dihydrogen phosphate TS (pH 2.5) and acetonitrile (19:1) to make exactly 10 mL. Confirm that the peak area of enalapril obtained with 50 μ L of this solution is equivalent to 7 to 13% of that with 50 μ L of the standard solution.

System performance: When the procedure is run with 50 μ L of the standard solution under the above operating conditions, the number of theoretical plates and the symmetry factor of the peak of enalapril are not less than 3000 and not more than 2.0, respectively.

System repeatability: When the test is repeated 6 times with 50 μ L of the standard solution under the above operating conditions, the relative standard deviation of the peak area of enalapril is not more than 2.0%.

Loss on drying <2.41> Not more than 1.0% (1 g, in vacuum, 60°C, 2 hours).

Residue on ignition <2.44> Not more than 0.2% (1 g).

Assay Weigh accurately about 30 mg each of Enalapril Maleate and Enalapril Maleate RS, both previously dried, and dissolve in a mixture of sodium dihydrogen phosphate TS (pH 2.5) and acetonitrile (19:1) to make exactly 100 mL, and use these solutions as the sample solution and standard solution. Perform the test with exactly 50 μ L each of the sample solution and standard solution as directed under Liquid Chromatography <2.01> according to the following conditions, and determine the peak areas, A_T and A_S , of enalapril in each solution.

$$\text{Amount (mg) of enalapril maleate (C}_{20}\text{H}_{28}\text{N}_2\text{O}_5\cdot\text{C}_4\text{H}_4\text{O}_4) \\ = M_S \times A_T/A_S$$

M_S : Amount (mg) of Enalapril Maleate RS taken

Operating conditions—

Detector: An ultraviolet absorption photometer (wavelength: 215 nm).

Column: A stainless steel column 4.1 mm in inside diameter and 15 cm in length, packed with porous styrene-divinylbenzene copolymer for liquid chromatography (5 μ m in particle diameter).

Column temperature: A constant temperature of about 70°C.

Mobile phase A: Dissolve 3.1 g of sodium dihydrogen phosphate dihydrate in 900 mL of water, adjust the pH to 6.8 with a solution of sodium hydroxide (1 in 4), and add water to make 1000 mL. To 950 mL of this solution, add 50 mL of acetonitrile for liquid chromatography.

Mobile phase B: Dissolve 3.1 g of sodium dihydrogen phosphate dihydrate in 900 mL of water, adjust the pH to 6.8 with a solution of sodium hydroxide (1 in 4), and add water to make 1000 mL. To 340 mL of this solution, add 660 mL of acetonitrile for liquid chromatography.

Flowing of mobile phase: Control the concentration gradient by changing the ratio of the mobile phases A and B as follows.

Time after injection of sample (min)	Mobile phase A (vol%)	Mobile phase B (vol%)
0	95	5
0 - 20	95 → 40	5 → 60
20 - 25	40	60

Flow rate: 1.4 mL per minute.

System suitability—

System performance: When the procedure is run with 50 μ L of the standard solution under the above operating conditions, the number of theoretical plates and the symmetry factor of the peak of enalapril are not less than 3000 and not more than 2.0, respectively.

System repeatability: When the test is repeated 6 times with 50 μ L of the standard solution under the above operating conditions, the relative standard deviation of the peak area of enalapril is not more than 1.0%.

Containers and storage Containers—Well-closed containers.

Enalapril Maleate Tablets

エナラプリルマレイン酸塩錠

Enalapril Maleate Tablets contain not less than 93.0% and not more than 107.0% of the labeled amount of enalapril maleate ($C_{20}H_{28}N_2O_5 \cdot C_4H_4O_4$; 492.52).

Method of preparation Prepare as directed under Tablets, with Enalapril Maleate.

Identification To a quantity of powdered Enalapril Maleate Tablets, equivalent to 50 mg of Enalapril Maleate, add 20 mL of methanol, shake, centrifuge, and then use the supernatant liquid as the sample solution. Separately, dissolve 25 mg of enalapril maleate in 10 mL of methanol, and use this solution as the standard solution. Perform the test with these solutions as directed under Thin-Layer Chromatography <2.03>. Spot 20 μ L each of the sample solution and standard solution on a plate of silica gel with fluorescent indicator for thin-layer chromatography. Develop the plate with a mixture of water, acetone, 1-butanol, acetic acid (100) and toluene (1:1:1:1) to a distance of about 10 cm, and air-dry the plate. Examine under ultraviolet light (main wavelength: 254 nm): the *R_f* values of the 2 spots obtained from the sample solution and the 2 spots from the standard solution are equivalent.

Purity Enalaprilat and enalapril diketopiperazine—Use the sample solution obtained in the Assay as the sample solution. Pipet 1 mL of the sample solution, add sodium dihydrogen phosphate TS (pH 2.2) to make exactly 100 mL, and use this solution as the standard solution. Perform the test with exactly 50 μ L each of the sample solution and standard solution as directed under Liquid Chromatography <2.01> according to the following conditions, and determine each peak area of both solutions by the automatic integration method: the peak area of enalaprilat, having the relative retention time of about 0.5 to enalapril obtained from the sample solution, is not larger than 2 times the peak area of enalapril from the standard solution. Also, the peak area of enalapril diketopiperazine, having the relative retention time of about 1.5 to enalapril, from the sample solution is not larger than the peak area of enalapril from the standard solution.

Operating conditions—

Proceed as directed in the operating conditions in the Assay.

System suitability—

System performance: Proceed as directed in the system suitability in the Assay.

Test for required detectability: Pipet 1 mL of the standard solution, and add sodium dihydrogen phosphate TS (pH 2.2) to make exactly 10 mL. Confirm that the peak area of enalapril obtained with 50 μ L of this solution is equivalent to 7 to 13% of that with 50 μ L of the standard solution.

System repeatability: When the test is repeated 6 times with 50 μ L of the standard solution under the above operating conditions, the relative standard deviation of the peak area of enalapril is not more than 2.0%.

Uniformity of dosage units <6.02> Perform the test according to the following method: it meets the requirement of the Content uniformity test.

Take 1 tablet of Enalapril Maleate Tablets, add $V/2$ mL of sodium dihydrogen phosphate TS (pH 2.2), sonicate for

15 minutes, shake for 30 minutes, and add sodium dihydrogen phosphate TS (pH 2.2) to make exactly V mL so that each mL contains about 0.1 mg of enalapril maleate ($C_{20}H_{28}N_2O_5 \cdot C_4H_4O_4$). Sonicate this solution for 15 minutes, filter through a membrane filter with a pore size not exceeding 0.45 μ m, and use the filtrate as the sample solution. Then, proceed as directed in the Assay.

$$\text{Amount (mg) of enalapril maleate } (C_{20}H_{28}N_2O_5 \cdot C_4H_4O_4) \\ = M_S \times A_T/A_S \times V/200$$

M_S : Amount (mg) of Enalapril Maleate RS taken

Dissolution <6.10> When the test is performed at 50 revolutions per minute according to the Paddle method, using 900 mL of water as the dissolution medium, the dissolution rates in 15 minutes of a 2.5- and 5-mg tablet and in 30 minutes of a 10-mg tablet are not less than 85%, respectively.

Start the test with 1 tablet of Enalapril Maleate Tablets, withdraw not less than 20 mL of the medium at the specified minute after starting the test, and filter through a membrane filter with a pore size not exceeding 0.45 μ m. Discard not less than 10 mL of the first filtrate, pipet V mL of the subsequent filtrate, add water to make exactly V' mL so that each mL contains about 2.8 μ g of enalapril maleate ($C_{20}H_{28}N_2O_5 \cdot C_4H_4O_4$), and use this solution as the sample solution. Separately, weigh accurately about 14 mg of Enalapril Maleate RS, previously dried in vacuum at 60°C for 2 hours, and dissolve in water to make exactly 500 mL. Pipet 5 mL of this solution, add water to make exactly 50 mL, and use this solution as the standard solution. Perform the test with exactly 50 μ L each of the sample solution and standard solution as directed under Liquid Chromatography <2.01> according to the following conditions, and determine the peak areas, A_T and A_S , of enalapril in each solution.

$$\text{Dissolution rate (\%)} \text{ with respect to the labeled amount} \\ \text{of enalapril maleate } (C_{20}H_{28}N_2O_5 \cdot C_4H_4O_4) \\ = M_S \times A_T/A_S \times V'/V \times 1/C \times 18$$

M_S : Amount (mg) of Enalapril Maleate RS taken

C : Labeled amount (mg) of enalapril maleate ($C_{20}H_{28}N_2O_5 \cdot C_4H_4O_4$) in 1 tablet

Operating conditions—

Detector, column, column temperature, and flow rate: Proceed as directed in the operating conditions in the Assay.

Mobile phase: Dissolve 1.88 g of sodium dihydrogen phosphate dihydrate in 900 mL of water, adjust the pH to 2.2 with phosphoric acid, and add water to make 1000 mL. To 750 mL of this solution add 250 mL of acetonitrile.

System suitability—

System performance: When the procedure is run with 50 μ L of the standard solution under the above operating conditions, the number of theoretical plates and the symmetry factor of the peak of enalapril are not less than 300 and not more than 2.0, respectively.

System repeatability: When the test is repeated 6 times with 50 μ L of the standard solution under the above operating conditions, the relative standard deviation of the peak area of enalapril is not more than 2.0%.

Assay Weigh accurately not less than 20 Enalapril Maleate Tablets, and powder. Weigh accurately a portion of the powder, equivalent to about 10 mg of enalapril maleate ($C_{20}H_{28}N_2O_5 \cdot C_4H_4O_4$), add 50 mL of sodium dihydrogen phosphate TS (pH 2.2), sonicate for 15 minutes, shake for 30 minutes, and then add sodium dihydrogen phosphate TS (pH 2.2) to make exactly 100 mL. Sonicate this solution for 15 minutes, filter through a membrane filter with a pore size

not exceeding $0.45 \mu\text{m}$, and use the filtrate as the sample solution. Separately, weigh accurately about 20 mg of Enalapril Maleate RS, previously dried in vacuum at 60°C for 2 hours, dissolve in sodium dihydrogen phosphate TS (pH 2.2) to make exactly 200 mL, and use this solution as the standard solution. Perform the test with exactly $50 \mu\text{L}$ each of the sample solution and standard solution as directed under Liquid Chromatography <2.01> according to the following conditions, and determine the peak areas, A_T and A_S , of enalapril in each solution.

$$\text{Amount (mg) of enalapril maleate (C}_{20}\text{H}_{28}\text{N}_2\text{O}_5 \cdot \text{C}_4\text{H}_4\text{O}_4) \\ = M_S \times A_T / A_S \times 1/2$$

M_S : Amount (mg) of Enalapril Maleate RS taken

Operating conditions—

Detector: An ultraviolet absorption photometer (wavelength: 215 nm).

Column: A stainless steel column 4.6 mm in inside diameter and 25 cm in length, packed with octylsilylated silica gel for liquid chromatography ($5 \mu\text{m}$ in particle diameter).

Column temperature: A constant temperature of about 50°C .

Mobile phase: A mixture of sodium dihydrogen phosphate TS (pH 2.2) and acetonitrile (3:1).

Flow rate: Adjust so that the retention time of enalapril is about 5 minutes.

System suitability—

System performance: Heat to fusion about 20 mg of enalapril maleate. After cooling, add 50 mL of acetonitrile, and sonicate to dissolve. To 1 mL of this solution, add the standard solution to make 50 mL, and use this solution as the solution for system suitability test. When the procedure is run with $50 \mu\text{L}$ of the solution for system suitability test under the above operating conditions, enalapril and enalapril diketopiperazine, which has a relative retention time of about 1.5 to enalapril, are eluted in this order with the resolution between these peaks being not less than 2.0.

System repeatability: When the test is repeated 6 times with $50 \mu\text{L}$ of the solution for system suitability test under the above operating conditions, the relative standard deviation of the peak area of enalapril is not more than 1.0%.

Containers and storage Containers—Well-closed containers.

Enflurane

エンフルラン

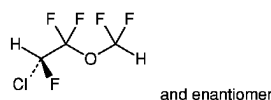

$\text{C}_3\text{H}_2\text{ClF}_5\text{O}$: 184.49
(2*RS*)-2-Chloro-1-(difluoromethoxy)-1,1,2-trifluoroethane
[13838-16-9]

Description Enflurane is a clear, colorless liquid.

It is slightly soluble in water.

It is miscible with ethanol (95) and with diethyl ether.

It is a volatile, and not an inflammable.

It shows no optical rotation.

Boiling point: $54 - 57^\circ\text{C}$

Identification (1) Take $50 \mu\text{L}$ of Enflurane, and prepare the test solution as directed to the Oxygen Flask Combustion Method <1.06> using 40 mL of water as the absorbing liquid.

The test solution responds to Qualitative Tests <1.09> for chloride and fluoride.

(2) Determine the infrared absorption spectrum of Enflurane as directed in the liquid film method under Infrared Spectrophotometry <2.25>, and compare the spectrum with the Reference Spectrum: both spectra exhibit similar intensities of absorption at the same wave numbers.

Refractive index <2.45> n_D^{20} : 1.302 – 1.304

Specific gravity <2.56> d_{20}^{20} : 1.520 – 1.540

Purity (1) Acidity or alkalinity—To 60 mL of Enflurane add 60 mL of freshly boiled and cooled water, shake for 3 minutes, separate the water layer, and use the layer as the sample solution. To 20 mL of the sample solution add one drop of bromocresol purple TS and 0.10 mL of 0.01 mol/L sodium hydroxide VS: the color of the solution is purple. To 20 mL of the sample solution add one drop of bromocresol purple TS and 0.06 mL of 0.01 mol/L hydrochloric acid VS: the color of the solution is yellow.

(2) Chloride <1.03>—To 20 g of Enflurane add 20 mL of water, shake well, and separate the water layer. Take 10 mL of the water layer add 6 mL of dilute nitric acid and water to make 50 mL, and perform the test using this solution as the test solution. Prepare the control solution with 0.30 mL of 0.01 mol/L hydrochloric acid VS (not more than 0.001%).

(3) Related substances—Proceed the test with $5 \mu\text{L}$ of Enflurane as directed under Gas chromatography <2.02> according to the following conditions. Determine each peak area other than the peak of air which appears soon after injection of the sample by the automatic integration method, and calculate the amount of each peak by the area percentage method: the amount of the substances other than enflurane is not more than 0.10%.

Operating conditions—

Detector: A thermal conductivity detector.

Column: A column 3 mm in inside diameter and 3 m in length, packed with siliceous earth for gas chromatography, 180 to $250 \mu\text{m}$ in particle diameter, coated with diethylene glycol succinate ester for gas chromatography in the ratio of 20%.

Column temperature: A constant temperature of about 80°C .

Carrier gas: Helium.

Flow rate: Adjust so that the retention time of enflurane is about 3 minutes.

Time span of measurement: About 3 times as long as the retention time of enflurane.

System suitability—

Test for required detectability: To exactly 1 mL of enflurane add 2-propanol to make exactly 100 mL. To exactly 2 mL of this solution add 2-propanol to make exactly 10 mL, and use this solution as the solution for system suitability test. Pipet 1 mL of the solution for system suitability test, and add 2-propanol to make exactly 10 mL. Confirm that the peak area of enflurane obtained with $5 \mu\text{L}$ of this solution is equivalent to 7 to 13% of that with $5 \mu\text{L}$ of the solution for system suitability test.

System performance: Mix 5 mL of Enflurane and 5 mL of 2-propanol. When the procedure is run with $5 \mu\text{L}$ of this mixture under the above operating conditions, enflurane and 2-propanol are eluted in this order with the resolution between these peaks being not less than 2.0.

System repeatability: When the test is repeated 6 times with $5 \mu\text{L}$ of the solution for system suitability test under the above operating conditions, the relative standard deviation of the peak area of enflurane is not more than 2.0%.

(4) Nonvolatile residue—Evaporate exactly 65 mL of Enflurane on a water bath to dryness, and dry the residue at 105°C for 1 hour: the residue is not more than 1.0 mg.

Water <2.48> Not more than 0.10% (10 g, volumetric titration, direct titration).

Containers and storage Containers—Tight containers.
Storage—Not exceeding 30°C.

Enoxacin Hydrate

エノキサシン水和物

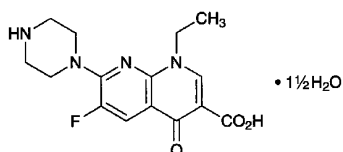

$C_{15}H_{17}FN_4O_3 \cdot \frac{1}{2}H_2O$: 347.34
1-Ethyl-6-fluoro-4-oxo-7-(piperazin-1-yl)-1,4-dihydro-1,8-naphthyridine-3-carboxylic acid sesquihydrate
[84294-96-2]

Enoxacin Hydrate, when dried, contains not less than 98.5% of enoxacin ($C_{15}H_{17}FN_4O_3$: 320.32).

Description Enoxacin Hydrate occurs as white to pale yellow-brown, crystals or crystalline powder.

It is freely soluble in acetic acid (100), slightly soluble in methanol, very slightly soluble in chloroform, and practically insoluble in water, in ethanol (95) and in diethyl ether.

It dissolves in dilute sodium hydroxide TS.

It is gradually colored by light.

Identification (1) Place 0.02 g of Enoxacin Hydrate and 0.05 g of sodium in a test tube, and heat gradually to ignition with precaution. After cooling, add 0.5 mL of methanol and then 5 mL of water, and heat to boiling. To this solution add 2 mL of dilute acetic acid, and filter: the filtrate responds to Qualitative Tests <1.09> (2) for fluoride.

(2) Dissolve 0.05 g of Enoxacin Hydrate in dilute sodium hydroxide TS to make 100 mL. To 1 mL of the solution add water to make 100 mL. Determine the absorption spectrum of the solution as directed under Ultraviolet-visible Spectrophotometry <2.24>, and compare the spectrum with the Reference Spectrum: both spectra exhibit similar intensities of absorption at the same wavelengths.

(3) Determine the infrared absorption spectrum of Enoxacin Hydrate as directed in the potassium bromide disk method under Infrared Spectrophotometry <2.25>, and compare the spectrum with the Reference Spectrum: both spectra exhibit similar intensities of absorption at the same wave numbers.

Melting point <2.60> 225 – 229°C (after drying).

Purity (1) Sulfate <1.14>—Dissolve 1.0 g of Enoxacin Hydrate in 50 mL of dilute sodium hydroxide TS, shake with 10 mL of dilute hydrochloric acid, and centrifuge. Filter the supernatant liquid, and to 30 mL of the filtrate add water to make 50 mL. Perform the test using this solution as the test solution. Prepare the control solution as follows: to 0.50 mL of 0.005 mol/L sulfuric acid VS add 25 mL of dilute sodium hydroxide TS, 5 mL of dilute hydrochloric acid TS and water to make 50 mL (not more than 0.048%).

(2) Heavy metals <1.07>—Proceed with 1.0 g of Enoxacin Hydrate according to Method 2, and perform the test.

Prepare the control solution with 2.0 mL of Standard Lead Solution (not more than 20 ppm).

(3) Arsenic <1.11>—Prepare the test solution with 1.0 g of Enoxacin Hydrate according to Method 3, and perform the test (not more than 2 ppm).

(4) Related substances—Dissolve 50 mg of Enoxacin Hydrate in 25 mL of a mixture of chloroform and methanol (7:3), and use this solution as the sample solution. Pipet 1 mL of the sample solution, add a mixture of chloroform and methanol (7:3) to make exactly 200 mL, and use this solution as the standard solution. Perform the test with these solutions as directed under Thin-layer Chromatography <2.03>. Spot 5 μ L each of the sample solution and standard solution on a plate of silica gel with fluorescent indicator for thin-layer chromatography. Develop the plate with a mixture of 1-butanol, water and acetic acid (100) (3:1:1) to a distance of about 10 cm, and air-dry the plate. Examine under ultraviolet light (main wavelength: 254 nm): the spots other than the principal spot obtained from the sample solution are not more intense than the spot from the standard solution.

Loss on drying <2.41> 7.0 – 9.0% (1 g, 105°C, 3 hours).

Residue on ignition <2.44> Not more than 0.1% (1 g, platinum crucible).

Assay Weigh accurately about 0.3 g of Enoxacin Hydrate, previously dried, dissolve in 30 mL of acetic acid (100), and titrate <2.50> with 0.1 mol/L perchloric acid VS (potentiometric titration). Perform a blank determination in the same manner, and make any necessary correction.

Each mL of 0.1 mol/L perchloric acid VS
= 32.03 mg of $C_{15}H_{17}FN_4O_3$

Containers and storage Containers—Tight containers.
Storage—Light-resistant.

Entacapone

エンタカポン

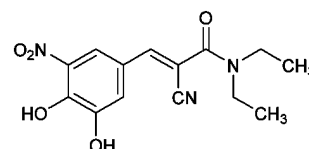

$C_{14}H_{15}N_3O_5$: 305.29
(2E)-2-Cyano-3-(3,4-dihydroxy-5-nitrophenyl)-N,N-diethylprop-2-enamide
[130929-57-6]

Entacapone contains not less than 98.0% and not more than 102.0% of entacapone ($C_{14}H_{15}N_3O_5$), calculated on the dried basis.

Description Entacapone occurs as a yellow to greenish yellow crystalline powder.

It is sparingly soluble in methanol, slightly soluble in ethanol (99.5), and practically insoluble in water.

It shows crystal polymorphism.

Identification (1) Dissolve 35 mg of Entacapone in 200 mL of methanol. To 7 mL of this solution add 0.1 mol/L hydrochloric acid TS to make 100 mL. Determine the absorption spectrum of this solution as directed under Ultraviolet-visible Spectrophotometry <2.24>, using a solution prepared by adding 0.1 mol/L hydrochloric acid TS to 7 mL of methanol to make 100 mL as the blank, and compare the spec-

trum with the Reference Spectrum or the spectrum of a solution of Entacapone RS prepared in the same manner as the sample solution: both spectra exhibit similar intensities of absorption at the same wavelengths.

(2) Determine the infrared absorption spectrum of Entacapone as directed in the potassium bromide disk method under Infrared Spectrophotometry <2.25>, and compare the spectrum with the Reference Spectrum or the spectrum of Entacapone RS: both spectra exhibit similar intensities of absorption at the same wave numbers.

Purity (1) Heavy metals—Dissolve 1.0 g of Entacapone in 20 mL of a mixture of methanol and *N,N*-dimethylformamide (3:1), and use this solution as the sample solution. Separately, weigh exactly 0.400 g of lead (II) nitrate, dissolve in water to make exactly 250 mL. Before use, dilute this solution with water to make exactly 10 times the initial volume, then dilute this solution with water to make exactly 10 times the initial volume. Pipet 1 mL of this solution, add a mixture of methanol and *N,N*-dimethylformamide (3:1) to make exactly 20 mL, and use this solution as the standard solution. To each of the sample solution and standard solution add 2 mL of acetate buffer solution (pH 3.5), mix, add 1.2 mL of thioacetamide TS, and mix immediately. Allow them to stand for 2 minutes, filter separately all the amount of each solution through a membrane filter with a pore size of 0.45 μm , wash the membrane filters with not less than 20 mL of methanol, and compare the colors on the membrane filters: the color obtained from the sample solution is not darker than that obtained from the standard solution (not more than 10 ppm).

(2) Halide—Being specified separately when the drug is granted approval based on the Law.

(3) Related substances—Dissolve 50 mg of Entacapone in 50 mL of a mixture of methanol and tetrahydrofuran (7:3), and use this solution as the sample solution. Pipet 5 mL of the sample solution, and add a mixture of methanol and tetrahydrofuran (7:3) to make exactly 50 mL. Pipet 5 mL of this solution, and add a mixture of methanol and tetrahydrofuran (7:3) to make exactly 50 mL. Pipet 1 mL of this solution, add a mixture of methanol and tetrahydrofuran (7:3) to make exactly 10 mL, and use this solution as the standard solution. Perform the test with exactly 10 μL each of the sample solution and standard solution as directed under Liquid Chromatography <2.01> according to the following conditions. Determine each peak area by the automatic integration method: the peak area of the related substance A, having the relative retention time of about 0.8 to entacapone, obtained from the sample solution is not larger than 1.5 times the peak area of entacapone from the standard solution, the area of the peak other than entacapone and the peak mentioned above from the sample solution is not larger than the peak area of entacapone from the standard solution, and the total area of the peaks other than entacapone and the related substance A, having the relative retention time of about 0.8 to entacapone, from the sample solution is not larger than 2 times the peak area of entacapone from the standard solution. For the areas of the peaks of related substances B and C, having the relative retention times of about 0.6 and about 1.4 to entacapone, multiply their correction factors, 1.7 and 2.5, respectively.

Operating conditions—

Detector, column, column temperature, mobile phase and flow rate: Proceed as directed in the operating conditions in the Assay.

Time span of measurement: About 2.5 times as long as the retention time of entacapone, beginning after the solvent

peak.

System suitability—

System performance: Proceed as directed in the system suitability in the Assay.

Test for required detectability: Pipet 5 mL of the standard solution, add a mixture of methanol and tetrahydrofuran (7:3) to make exactly 10 mL. Confirm that the peak area of entacapone obtained with 10 μL of this solution is equivalent to 35 to 65% of that obtained with 10 μL of the standard solution.

System repeatability: When the test is repeated 5 times with 10 μL of the standard solution under the above operating conditions, the relative standard deviation of the peak area of entacapone is not more than 5%.

Loss on drying <2.41> Not more than 0.5% (1 g, in vacuum, 60°C, 3 hours).

Residue on ignition <2.44> Not more than 0.1% (1 g).

Assay Weigh accurately about 50 mg each of Entacapone and Entacapone RS (separately determine the loss on drying <2.41> under the same conditions as Entacapone), dissolve each in a mixture of methanol and tetrahydrofuran (7:3) to make exactly 50 mL. Pipet 5 mL each of these solutions, add a mixture of methanol and tetrahydrofuran (7:3) to make exactly 50 mL, and use these solutions as the sample solution and the standard solution, respectively. Perform the test with exactly 10 μL each of the sample solution and standard solution as directed under Liquid Chromatography <2.01> according to the following conditions, and determine the peak areas, A_T and A_S , of entacapone in each solution.

$$\begin{aligned} &\text{Amount (mg) of entacapone (C}_{14}\text{H}_{15}\text{N}_3\text{O}_5) \\ &= M_S \times A_T/A_S \end{aligned}$$

M_S : Amount (mg) of Entacapone RS taken, calculated on the dried basis

Operating conditions—

Detector: An ultraviolet absorption photometer (wavelength: 300 nm).

Column: A stainless steel column 4.6 mm in inside diameter and 25 cm in length, packed with phenylated silica gel for liquid chromatography (5 μm in particle diameter).

Column temperature: A constant temperature of about 25°C.

Mobile phase: Dissolve 2.34 g of sodium dihydrogen phosphate dihydrate in water to make 1000 mL, and adjust to pH 2.1 with phosphoric acid. To 540 mL of this solution add 440 mL of methanol and 20 mL of tetrahydrofuran.

Flow rate: 1 mL per minute.

System suitability—

System performance: Dissolve 5 mg of Entacapone Related Substance A for System Suitability RS in a mixture of methanol and tetrahydrofuran (7:3) to make 25 mL. To 1 mL of this solution add a mixture of methanol and tetrahydrofuran (7:3) to make 20 mL, and use this solution as the solution for system suitability test. Separately, to 5 mL of the standard solution add a mixture of methanol and tetrahydrofuran (7:3) to make 50 mL. To 1 mL of this solution and 1 mL of the solution for system suitability test add a mixture of methanol and tetrahydrofuran (7:3) to make 10 mL. When the procedure is run with 10 μL of this solution under the above operating conditions, the related substance A and entacapone are eluted in this order with the resolution between these peaks being not less than 3.

System repeatability: When the test is repeated 6 times with 10 μL of the standard solution under the above operating conditions, the relative standard deviation of the peak

area of entacapone is not more than 1.0%.

Containers and storage Containers—Well-closed containers.

Others

Related substance A:

(2*Z*)-2-Cyano-3-(3,4-dihydroxy-5-nitrophenyl)-*N,N*-diethylprop-2-enamide

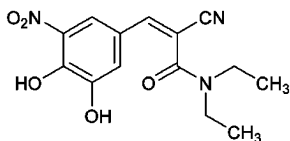

Related substance B:

(2*E*)-2-Cyano-3-(3,4-dihydroxyphenyl)-*N,N*-diethylprop-2-enamide

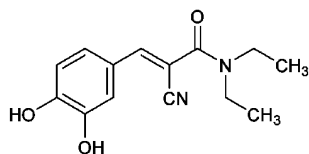

Related substance C:

(2*E*)-3-(3-Bromo-4,5-dihydroxyphenyl)-2-cyano-*N,N*-diethylprop-2-enamide

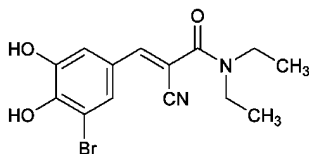

Entacapone Tablets

エンタカポン錠

Entacapone Tablets contain not less than 95.0% and not more than 105.0% of the labeled amount of entacapone ($C_{14}H_{15}N_3O_5$; 305.29).

Method of preparation Prepare as directed under Tablets, with Entacapone.

Identification To 1 mL of the sample solution obtained in the Assay add methanol to make 50 mL. Determine the absorption spectrum of this solution as directed under Ultraviolet-visible Spectrophotometry <2.24>: it exhibits a maximum between 301 nm and 305 nm.

Uniformity of dosage units <6.02> Perform the Mass variation test, or the Content uniformity test according to the following method: it meets the requirement.

Conduct this procedure using light-resistant vessels. To 1 tablet of Entacapone Tablets add 70 mL of methanol, shake for 5 minutes, and add 60 mL of tetrahydrofuran. Sonicate for 3 minutes, shake for 5 minutes, and add methanol to make exactly 200 mL. Centrifuge this solution, pipet V mL of the supernatant liquid, add methanol to make exactly V' mL so that each mL contains about 0.5 mg of entacapone ($C_{14}H_{15}N_3O_5$), and use this solution as the sample solution. Then, proceed as directed in the Assay.

$$\begin{aligned} &\text{Amount (mg) of entacapone (C}_{14}\text{H}_{15}\text{N}_3\text{O}_5) \\ &= M_S \times A_T/A_S \times V'/V \times 2 \end{aligned}$$

M_S : Amount (mg) of Entacapone RS taken, calculated on the dried basis

Dissolution <6.10> When the test is performed at 50 revolutions per minute according to the Paddle method, using 900 mL of 0.05 mol/L potassium dihydrogen phosphate TS, adjusted to pH 5.5 with sodium hydroxide TS, as the dissolution medium, the dissolution rate in 30 minutes of Entacapone Tablets is not less than 80%.

Start the test with 1 tablet of Entacapone Tablets, withdraw not less than 15 mL of the medium at the specified minute after starting the test, and filter through a membrane filter with a pore size not exceeding 0.45 μm . Discard not less than 5 mL of the first filtrate, pipet V mL of the subsequent filtrate, add the dissolution medium to make exactly V' mL so that each mL contains about 11 μg of entacapone ($C_{14}H_{15}N_3O_5$), and use this solution as the sample solution. Separately, weigh accurately about 22 mg of Entacapone RS (separately determine the loss on drying <2.41> under the same conditions as Entacapone), add 4 mL of methanol, dissolve by sonicating, and add the dissolution medium to make exactly 200 mL. Pipet 5 mL of this solution, add the dissolution medium to make exactly 50 mL, and use this solution as the standard solution. Determine the absorbances, A_T and A_S , of the sample solution and standard solution at 313 nm as directed under Ultraviolet-visible Spectrophotometry <2.24>, using the dissolution medium as the blank.

$$\begin{aligned} &\text{Dissolution rate (\%)} \text{ with respect to the labeled amount} \\ &\text{of entacapone (C}_{14}\text{H}_{15}\text{N}_3\text{O}_5) \\ &= M_S \times A_T/A_S \times V'/V \times 1/C \times 45 \end{aligned}$$

M_S : Amount (mg) of Entacapone RS taken, calculated on the dried basis

C : Labeled amount (mg) of entacapone ($C_{14}H_{15}N_3O_5$) in 1 tablet

Assay Conduct this procedure using light-resistant vessels. Weigh accurately the mass of not less than 20 Entacapone Tablets, and powder. Weigh accurately a portion of the powder, equivalent to about 0.1 g of entacapone ($C_{14}H_{15}N_3O_5$), add 60 mL of tetrahydrofuran, and sonicate for 3 minutes. Add 60 mL of methanol, shake for 5 minutes, and add methanol to make exactly 200 mL. Centrifuge this solution, and use the supernatant liquid as the sample solution. Separately, weigh accurately about 50 mg of Entacapone RS (separately determine the loss on drying <2.41> under the same conditions as Entacapone), dissolve in 30 mL of tetrahydrofuran, add methanol to make exactly 100 mL, and use this solution as the standard solution. Perform the test with exactly 10 μL each of the sample solution and standard solution as directed under Liquid Chromatography <2.01> according to the following conditions, and determine the peak areas, A_T and A_S , of entacapone in each solution.

$$\begin{aligned} &\text{Amount (mg) of entacapone (C}_{14}\text{H}_{15}\text{N}_3\text{O}_5) \\ &= M_S \times A_T/A_S \times 2 \end{aligned}$$

M_S : Amount (mg) of Entacapone RS taken, calculated on the dried basis

Operating conditions—

Detector: An ultraviolet absorption photometer (wavelength: 300 nm).

Column: A stainless steel column 4.6 mm in inside diameter and 25 cm in length, packed with phenylated silica gel for liquid chromatography (5 μm in particle diameter).

Column temperature: A constant temperature of about 25°C.

Mobile phase: Dissolve 2.34 g of sodium dihydrogen phosphate dihydrate in water, add 2 mL of phosphoric acid, and add water to make 1000 mL. To 540 mL of this solution add 440 mL of methanol and 20 mL of tetrahydrofuran.

Flow rate: Adjust so that the retention time of entacapone is about 12 minutes.

System suitability—

System performance: To 20 mL of the standard solution add a mixture of methanol and tetrahydrofuran (7:3) to make 50 mL, and use this solution as the solution for system suitability test. Separately, dissolve 5 mg of Entacapone Related Substance A for System Suitability RS in a mixture of methanol and tetrahydrofuran (7:3) to make 25 mL. To 15 mL of this solution and 15 mL of the solution for system suitability test add a mixture of methanol and tetrahydrofuran (7:3) to make 100 mL. When the procedure is run with 10 μ L of this solution under the above operating conditions, the related substance A, having the relative retention time of about 0.8 to entacapone, and entacapone are eluted in this order with the resolution between these peaks being not less than 2.0.

System repeatability: When the test is repeated 6 times with 10 μ L of the standard solution under the above operating conditions, the relative standard deviation of the peak area of entacapone is not more than 1.0%.

Containers and storage Containers—Tight containers.

Others

Related substance A: refer to it described in Entacapone.

Enviomycin Sulfate

エンビオマイシン硫酸塩

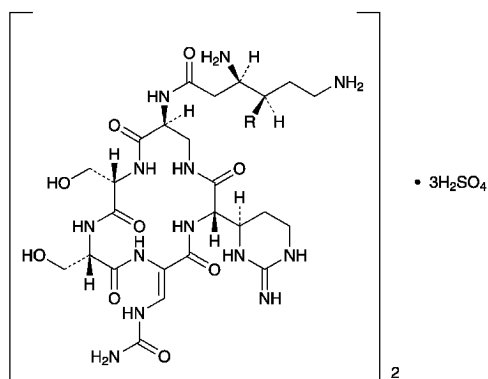

Tuberactinomycin N Sulfate : R = OH
Tuberactinomycin O Sulfate : R = H

Tuberactinomycin N Sulfate
(C₂₅H₄₃N₁₃O₁₀)₂·3H₂SO₄: 1665.62

Tuberactinomycin O Sulfate
(C₂₅H₄₃N₁₃O₉)₂·3H₂SO₄: 1633.62

Tuberactinomycin N Sulfate
(3*R*,4*R*)-*N*-[(3*S*,9*S*,12*S*,15*S*)-9,12-Bis(hydroxymethyl)-3-[(4*R*)-2-iminohexahydropyrimidin-4-yl]-2,5,8,11,14-pentaoxo-6-(*Z*)-ureidomethylene-1,4,7,10,13-pentaazacyclohexadec-15-yl]-3,6-diamino-4-hydroxyhexanamide sesquisulfate
[33103-22-9, Tuberactinomycin N]

Tuberactinomycin O Sulfate
(3*S*)-*N*-[(3*S*,9*S*,12*S*,15*S*)-9,12-Bis(hydroxymethyl)-3-[(4*R*)-2-iminohexahydropyrimidin-4-yl]-2,5,8,11,14-pentaoxo-6-(*Z*)-ureidomethylene-1,4,7,10,13-pentaazacyclohexadec-15-yl]-3,6-diaminohexanamide sesquisulfate
[33137-73-4, Tuberactinomycin O]

Enviomycin Sulfate is the sulfate of a mixture of peptide substances having antibacterial activity produced by the growth of *Streptomyces griseoverticillatus* var. *tuberacticus*.

It contains not less than 770 μ g (potency) and not more than 920 μ g (potency) per mg, calculated on the dried basis. The potency of Enviomycin Sulfate is expressed as mass (potency) of tuberactinomycin N (C₂₅H₄₃N₁₃O₁₀: 685.69).

Description Enviomycin Sulfate occurs as a white powder.

It is very soluble in water, and practically insoluble in ethanol (99.5).

Identification (1) To 5 mL of a solution of Enviomycin Sulfate (1 in 200) add 1.5 mL of sodium hydroxide TS, and add 1 drop of a mixture of 0.01 mol/L citric acid TS and copper (II) sulfate TS (97:3) : a blue-purple color develops.

(2) Determine the absorption spectrum of a solution of Enviomycin Sulfate (1 in 100,000) as directed under Ultraviolet-visible Spectrophotometry <2.24>, and compare the spectrum with the Reference Spectrum: both spectra exhibit similar intensities of absorption at the same wavelengths.

(3) To 2 mL of a solution of Enviomycin Sulfate (1 in 20) add 1 drop of barium chloride TS: a white precipitate is produced.

Optical rotation <2.49> $[\alpha]_D^{20}$: -16 - -22° (0.5 g calculated on the dried basis, water, 50 mL, 100 mm).

pH <2.54> The pH of a solution obtained by dissolving 2.0 g of Enviomycin Sulfate in 20 mL of water is between 5.5 and 7.5.

Content ratio of the active principle Dissolve 0.1 g of Enviomycin Sulfate in water to make 100 mL, and use this solution as the sample solution. Perform the test with 3 μ L of the sample solution as directed under Liquid Chromatography <2.01> according to the following conditions, and determine the peak areas, *A*_{T1} and *A*_{T2}, of tuberactinomycin N and tuberactinomycin O, having the relative retention time, 1.4 ± 0.4, to tuberactinomycin N, by the automatic integration method: *A*_{T2}/*A*_{T1} + *A*_{T2} is between 0.090 and 0.150.

Operating conditions—

Detector: An ultraviolet absorption photometer (wavelength: 254 nm).

Column: A stainless steel column 4.6 mm in inside diameter and 15 cm in length, packed with silica gel for liquid chromatography (5 μ m in particle diameter).

Column temperature: A constant temperature of about 25°C.

Mobile phase: A mixture of ammonium acetate TS, 1,4-dioxane, tetrahydrofuran, water and ammonia solution (28) (100:75:50:23:2).

Flow rate: Adjust so that the retention time of tuberactinomycin N is about 9 minutes.

System suitability—

System performance: When the procedure is run with 3 μ L of the sample solution under the above operating conditions, tuberactinomycin N and tuberactinomycin O are eluted in this order with the resolution between these peaks being not less than 1.5.

System repeatability: When the test is repeated 6 times with 3 μ L of the sample solution under the above operating conditions, the relative standard deviation of the peak area of tuberactinomycin N is not more than 2.0%.

Purity (1) Clarity and color of solution—Dissolve 1.0 g of Enviomycin Sulfate in 10 mL of water: the solution is clear and colorless.

(2) Heavy metals <1.07>—Proceed with 2.0 g of Enviomycin Sulfate according to Method 1, and perform the test. Prepare the control solution with 2.0 mL of Standard Lead Solution (not more than 10 ppm).

(3) Arsenic <1.11>—Prepare the test solution with 2.0 g of Enviomycin Sulfate according to Method 1, and perform the test (not more than 1 ppm).

Loss on drying <2.41> Not more than 4.0% (0.2 g, in vacuum, phosphorus (V) oxide, 60°C, 3 hours).

Assay Perform the test according to the Cylinder-plate method as directed under Microbial Assay for Antibiotics <4.02> according to the following conditions.

(i) Test organism—*Bacillus subtilis* ATCC 6633

(ii) Culture medium—Use the medium i in 1) Medium for test organism [5] under (1) Agar media for seed and base layer.

(iii) Standard solutions—Weigh accurately an amount of Enviomycin Sulfate RS, equivalent to about 20 mg (potency), dissolve in water to make exactly 20 mL, and use this solution as the standard stock solution. Keep the standard stock solution at a temperature not exceeding 5°C and use within 10 days. Take exactly a suitable amount of the standard stock solution before use, add 0.1 mol/L phosphate buffer solution (pH 8.0) to make solutions so that each mL contains 400 µg (potency) and 100 µg (potency), and use these solutions as the high concentration standard solution and the low concentration standard solution, respectively.

(iv) Sample solutions—Weigh accurately an amount of Enviomycin Sulfate, equivalent to about 20 mg (potency), and dissolve in water to make exactly 20 mL. Take exactly a suitable amount of this solution, add 0.1 mol/L phosphate buffer solution (pH 8.0) to make solutions so that each mL contains 400 µg (potency) and 100 µg (potency), and use these solutions as the high concentration sample solution and the low concentration sample solution, respectively.

Containers and storage Containers—Tight containers.

Epalrestat

エパルレストアット

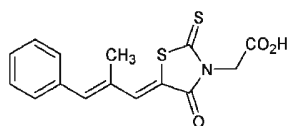

$C_{15}H_{13}NO_3S_2$: 319.40

2-[(5Z)-5-[(2E)-2-Methyl-3-phenylprop-2-en-1-ylidene]-4-oxo-2-thioxothiazolidin-3-yl]acetic acid
[82159-09-9]

Epalrestat, when dried, contains not less than 98.0% and not more than 102.0% of epalrestat ($C_{15}H_{13}NO_3S_2$).

Description Epalrestat occurs as yellow to orange, crystals or crystalline powder.

It is soluble in *N,N*-dimethylformamide, slightly soluble in methanol and in ethanol (99.5), and practically insoluble in water.

It gradually fades the color and decomposes on exposure to light.

It shows crystal polymorphism.

Identification (1) Determine the absorption spectrum of a

solution of Epalrestat in methanol (1 in 200,000) as directed under Ultraviolet-visible Spectrophotometry <2.24>, and compare the spectrum with the Reference Spectrum or the spectrum of a solution of Epalrestat RS prepared in the same manner as the sample solution: both spectra exhibit similar intensities of absorption at the same wavelengths.

(2) Determine the infrared absorption spectrum of Epalrestat as directed in the potassium bromide disk method under Infrared Spectrophotometry <2.25>, and compare the spectrum with the Reference Spectrum or the spectrum of Epalrestat RS: both spectra exhibit similar intensities of absorption at the same wave numbers. If any difference appears between the spectra, proceed as follows, using a light-resistant vessel. To 0.1 g of Epalrestat add 40 mL of methanol, dissolve the sample by warming in a water bath, and filter while hot, and cool in ice. Collect the crystals formed, dry, and perform the test.

Melting point <2.60> 222 – 227°C

Purity (1) Heavy metals <1.07>—Proceed with 2.0 g of Epalrestat according to Method 2, and perform the test. Prepare the control solution with 2.0 mL of Standard Lead Solution (not more than 10 ppm).

(2) Related substances—Conduct this procedure using light-resistant vessels. Dissolve about 20 mg of Epalrestat in 8 mL of *N,N*-dimethylformamide, and use this solution as the sample solution. Pipet 1 mL of the sample solution, add *N,N*-dimethylformamide to make exactly 100 mL, and use this solution as the standard solution. Perform the test with exactly 3 µL each of the sample solution and standard solution as directed under Liquid Chromatography <2.01> according to the following conditions. Determine each peak area by the automatic integration method: the area of the peak other than epalrestat obtained from the sample solution is not larger than 1/5 times the peak area of epalrestat from the standard solution, and the total area of the peaks other than epalrestat from the sample solution is not larger than the peak area of epalrestat from the standard solution.

Operating conditions—

Detector, column, column temperature, mobile phase, and flow rate: Proceed as directed in the operating conditions in the Assay.

Time span of measurement: About 3 times as long as the retention time of epalrestat, beginning after the solvent peak.

System suitability—

Test for required detectability: Pipet 1 mL of the standard solution, and add *N,N*-dimethylformamide to make exactly 10 mL. Confirm that the peak area of epalrestat obtained with 3 µL of this solution is equivalent to 7 to 13% of that with 3 µL of the standard solution.

System performance: When the procedure is run with 3 µL of the standard solution under the above operating conditions, the number of theoretical plates and the symmetry factor of the peak of epalrestat are not less than 6000 and not more than 1.5, respectively.

System repeatability: When the test is repeated 6 times with 3 µL of the standard solution under the above operating conditions, the relative standard deviation of the peak area of epalrestat is not more than 2.0%.

Loss on drying <2.41> Not more than 0.2% (1 g, in vacuum, silica gel, 60°C, 3 hours).

Residue on ignition <2.44> Not more than 0.1% (1 g).

Assay Conduct this procedure using light-resistant vessels. Weigh accurately about 20 mg each of Epalrestat and Epal-

restat RS, both previously dried, and separately dissolve in 8 mL of *N,N*-dimethylformamide, and add exactly 2 mL of the internal standard solution. To 2 mL each of these solutions add *N,N*-dimethylformamide to make 20 mL, and use these solutions as the sample solution and the standard solution, respectively. Perform the test with 3 μ L each of the sample solution and standard solution as directed under Liquid Chromatography <2.01> according to the following conditions, and calculate the ratios, Q_T and Q_S , of the peak area of epalrestat to that of the internal standard.

$$\text{Amount (mg) of epalrestat (C}_{15}\text{H}_{13}\text{NO}_3\text{S}_2) = M_S \times Q_T/Q_S$$

M_S : Amount (mg) of Epalrestat RS taken

Internal standard solution—A solution of propyl parahydroxybenzoate in *N,N*-dimethylformamide (1 in 100).

Operating conditions—

Detector: An ultraviolet absorption photometer (wavelength: 280 nm).

Column: A stainless steel column 4.6 mm in inside diameter and 15 cm in length, packed with octadecylsilylated silica gel for liquid chromatography (5 μ m in particle diameter).

Column temperature: A constant temperature of about 25°C.

Mobile phase: To 0.05 mol/L potassium dihydrogen phosphate TS add 0.05 mol/L disodium hydrogen phosphate TS so that the pH of this mixture is 6.5. To 2 volumes of this mixture add 1 volume of acetonitrile.

Flow rate: Adjust so that the retention time of epalrestat is about 12 minutes.

System suitability—

System performance: When the procedure is run with 3 μ L of the standard solution under the above operating conditions, epalrestat and the internal standard are eluted in this order with the resolution between these peaks being not less than 2.0.

System repeatability: When the test is repeated 6 times with 3 μ L of the standard solution under the above operating conditions, the relative standard deviation of the ratio of the peak area of epalrestat to that of the internal standard is not more than 1.0%.

Containers and storage Containers—Tight containers.

Storage—Light-resistant.

Epalrestat Tablets

エパルレスタット錠

Epalrestat Tablets contain not less than 95.0% and not more than 105.0% of the labeled amount of epalrestat (C₁₅H₁₃NO₃S₂; 319.40).

Method of preparation Prepare as directed under Tablets, with Epalrestat.

Identification (1) Powder Epalrestat Tablets. To a portion of the powder, equivalent to 50 mg of Epalrestat, add 100 mL of methanol, shake thoroughly, and filter. To 1 mL of the filtrate add methanol to make 100 mL. Determine the absorption spectrum of this solution as directed under Ultraviolet-visible Spectrophotometry <2.24>: it exhibits maxima between 235 nm and 239 nm, between 290 nm and 294 nm, and between 387 nm and 391 nm.

Uniformity of dosage units <6.02> Perform the Mass variation test, or the Content uniformity test according to the following method: it meets the requirement.

Conduct this procedure using light-resistant vessels. To 1 tablet of Epalrestat Tablets add exactly 30 mL of *N,N*-dimethylformamide, shake thoroughly to completely disintegrate the tablet, and centrifuge. Pipet 1 mL of the supernatant liquid, and add *N,N*-dimethylformamide to make exactly 100 mL. Pipet V mL of this solution, add exactly V' mL of *N,N*-dimethylformamide so that each mL contains about 4.2 μ g of epalrestat (C₁₅H₁₃NO₃S₂), and use this solution as the sample solution. Separately, weigh accurately about 50 mg of Epalrestat RS, previously dried in vacuum at 60°C for 3 hours with silica gel as a desiccant, and dissolve in exactly 30 mL of *N,N*-dimethylformamide. Pipet 1 mL of this solution, add *N,N*-dimethylformamide to make exactly 100 mL. Pipet 5 mL of this solution, add *N,N*-dimethylformamide to make exactly 20 mL, and use this solution as the standard solution. Determine the absorbances, A_T and A_S , at 392 nm of the sample solution and standard solution as directed under Ultraviolet-visible Spectrophotometry <2.24>.

$$\begin{aligned} \text{Amount (mg) of epalrestat (C}_{15}\text{H}_{13}\text{NO}_3\text{S}_2) \\ = M_S \times A_T/A_S \times V'/V \times 1/4 \end{aligned}$$

M_S : Amount (mg) of Epalrestat RS taken

Dissolution <6.10> When the test is performed at 50 revolutions per minute according to the Paddle method, using 900 mL of 2nd fluid for dissolution test as the dissolution medium, the dissolution rate in 45 minutes of Epalrestat Tablets is not less than 70%.

Conduct this procedure using light-resistant vessels. Start the test with 1 tablet of Epalrestat Tablets, withdraw not less than 20 mL of the medium at the specified minute after starting the test, and filter through a membrane filter with a pore size not exceeding 0.45 μ m. Discard not less than 10 mL of the first filtrate, pipet V mL of the subsequent filtrate, add the dissolution medium to make exactly V' mL so that each mL contains about 5.6 μ g of epalrestat (C₁₅H₁₃NO₃S₂), and use this solution as the sample solution. Separately, weigh accurately about 22 mg of Epalrestat RS, previously dried in vacuum at 60°C for 3 hours with silica gel as a desiccant, dissolve in 10 mL of *N,N*-dimethylformamide, and add the dissolution medium to make exactly 100 mL. Pipet 5 mL of this solution, add the dissolution medium to make exactly 200 mL, and use this solution as the standard solution. Determine the absorbances, A_T and A_S , at 398 nm of the sample solution and standard solution as directed under Ultraviolet-visible Spectrophotometry <2.24>, using the dissolution medium as the control.

Dissolution rate (%) with respect to the labeled amount of epalrestat (C₁₅H₁₃NO₃S₂)

$$= M_S \times A_T/A_S \times V'/V \times 1/C \times 45/2$$

M_S : Amount (mg) of Epalrestat RS taken

C : Labeled amount (mg) of epalrestat (C₁₅H₁₃NO₃S₂) in 1 tablet

Assay Conduct this procedure using light-resistant vessels. Weigh accurately the mass of not less than 20 Epalrestat Tablets, and powder. Weigh accurately a portion of the powder, equivalent to about 50 mg of epalrestat (C₁₅H₁₃NO₃S₂), add 20 mL of *N,N*-dimethylformamide, add exactly 5 mL of the internal standard solution, shake, and centrifuge. To 2 mL of the supernatant liquid add *N,N*-dimethylformamide to make 20 mL, and use this solution as the sample solution. Separately, weigh accurately about 20 mg of Epalrestat RS, previously dried in vacuum at 60°C for 3 hours with silica gel as a desiccant, dissolve in 8 mL of *N,N*-dimethylformamide, add exactly 2 mL of the internal standard solution, and shake. To 2 mL of this solution add

N,N-dimethylformamide to make 20 mL, and use this solution as the standard solution. Then, proceed as directed in the Assay under Epalrestat.

$$\begin{aligned} \text{Amount (mg) of epalrestat (C}_{15}\text{H}_{13}\text{NO}_3\text{S}_2) \\ = M_S \times Q_T / Q_S \times 5/2 \end{aligned}$$

M_S : Amount (mg) of Epalrestat RS taken

Internal standard solution—A solution of propyl parahydroxybenzoate in *N,N*-dimethylformamide (1 in 100).

Containers and storage Containers—Tight containers.

Eperisone Hydrochloride

エペリゾン塩酸塩

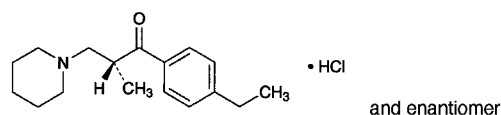

$\text{C}_{17}\text{H}_{25}\text{NO} \cdot \text{HCl}$: 295.85

(*2RS*)-1-(4-Ethylphenyl)-2-methyl-3-piperidin-1-ylpropan-1-one monohydrochloride
[56839-43-1]

Eperisone Hydrochloride contains not less than 98.5% and not more than 101.0% of eperisone hydrochloride ($\text{C}_{17}\text{H}_{25}\text{NO} \cdot \text{HCl}$), calculated on the anhydrous basis.

Description Eperisone Hydrochloride occurs as a white crystalline powder.

It is freely soluble in water, in methanol and in acetic acid (100), and soluble in ethanol (99.5).

Melting point: about 167°C (with decomposition).

A solution of Eperisone Hydrochloride in methanol (1 in 100) shows no optical rotation.

Identification (1) Determine the absorption spectrum of a solution of Eperisone Hydrochloride in methanol (1 in 100,000) as directed under Ultraviolet-visible Spectrophotometry <2.24>, and compare the spectrum with the Reference Spectrum: both spectra exhibit similar intensities of absorption at the same wavelengths.

(2) Determine the infrared absorption spectrum of Eperisone Hydrochloride as directed in the potassium chloride disk method under Infrared Spectrophotometry <2.25>, and compare the spectrum with the Reference Spectrum: both spectra exhibit similar intensities of absorption at the same wave numbers.

(3) A solution of Eperisone Hydrochloride (1 in 50) responds to Qualitative Tests <1.09> for chloride.

Purity (1) Heavy metals <1.07>—Proceed with 1.0 g of Eperisone Hydrochloride according to Method 1, and perform the test. Prepare the control solution with 2.0 mL of Standard Lead Solution (not more than 20 ppm).

(2) Piperidine hydrochloride—Dissolve 1.0 g of Eperisone Hydrochloride in 20 mL of water, add 2.0 mL of diluted hydrochloric acid (1 in 2), 2.0 mL of a solution of copper (II) sulfate pentahydrate (1 in 20) and 1.5 mL of ammonia solution (28), and use this solution as the sample solution. Separately, to 2.0 mL of a solution of piperidine hydrochloride (1 in 1000) add 18 mL of water, 2.0 mL of diluted hydrochloric acid (1 in 2), 2.0 mL of a solution of copper (II) sulfate pentahydrate (1 in 20) and 1.5 mL of ammonia solution (28), and use this solution as the standard solution. To

each of the sample solution and standard solution add 10 mL of a mixture of isopropylether and carbon disulfide (3:1), shake for 30 seconds, allow them to stand for 2 minutes, and compare the color of the upper layer: the color obtained from the sample solution is not more darker than that obtained from the standard solution.

(3) Related substances—Dissolve 0.1 g of Eperisone Hydrochloride in 100 mL of the mobile phase, and use this solution as the sample solution. Pipet 1 mL of the sample solution, add the mobile phase to make exactly 100 mL, and use this solution as the standard solution. Perform the test with exactly 10 μL each of the sample solution and standard solution as directed under Liquid Chromatography <2.01> according to the following conditions, and determine each peak area by the automatic integration method: the total area of the peaks other than eperisone obtained from the sample solution is not larger than 1/5 times the peak area of eperisone from the standard solution.

Operating conditions—

Detector: An ultraviolet absorption photometer (wavelength: 254 nm).

Column: A stainless steel column 4.6 mm in inside diameter and 15 cm in length, packed with octadecylsilanized silica gel for liquid chromatography (5 μm in particle diameter).

Column temperature: A constant temperature of about 30°C.

Mobile phase: A mixture of methanol, 0.0375 mol/L sodium 1-decanesulfonate TS and perchloric acid (600:400:1).

Flow rate: Adjust so that the retention time of eperisone is about 17 minutes.

Time span of measurement: About 2 times as long as the retention time of eperisone.

System suitability—

Test for required detectability: Pipet 1 mL of the standard solution, and add the mobile phase to make exactly 10 mL. Confirm that the peak area of eperisone obtained with 10 μL of this solution is equivalent to 7 to 13% of that with 10 μL of the standard solution.

System performance: When the procedure is run with 10 μL of the standard solution under the above operating conditions, the number of theoretical plates and the symmetry factor of the peak of eperisone are not less than 4000 and not more than 2.0, respectively.

System repeatability: When the test is repeated 6 times with 10 μL of the standard solution under the above operating conditions, the relative standard deviation of the peak area of eperisone is not more than 3.0%.

Water <2.48> Not more than 0.20% (0.1 g, coulometric titration).

Residue on ignition <2.44> Not more than 0.2% (1 g).

Assay Weigh accurately about 0.6 g of Eperisone Hydrochloride, dissolve in 20 mL of acetic acid (100), add 80 mL of acetic anhydride, and titrate <2.50> with 0.1 mol/L perchloric acid VS (potentiometric titration). Perform a blank determination in the same manner, and make any necessary correction.

$$\begin{aligned} \text{Each mL of 0.1 mol/L perchloric acid VS} \\ = 29.59 \text{ mg of } \text{C}_{17}\text{H}_{25}\text{NO} \cdot \text{HCl} \end{aligned}$$

Containers and storage Containers—Well-closed containers.

Ephedrine Hydrochloride

エフェドリン塩酸塩

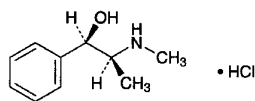

$C_{10}H_{15}NO \cdot HCl$: 201.69

(1*R*,2*S*)-2-Methylamino-1-phenylpropan-1-ol
monohydrochloride
[50-98-6]

Ephedrine Hydrochloride, when dried, contains not less than 99.0% of ephedrine hydrochloride ($C_{10}H_{15}NO \cdot HCl$).

Description Ephedrine Hydrochloride occurs as white, crystals or crystalline powder.

It is freely soluble in water, soluble in ethanol (95), slightly soluble in acetic acid (100), and practically insoluble in acetonitrile and in acetic anhydride.

Identification (1) Determine the absorption spectrum of a solution of Ephedrine Hydrochloride (1 in 2000) as directed under Ultraviolet-visible Spectrophotometry <2.24>, and compare the spectrum with the Reference Spectrum: both spectra exhibit similar intensities of absorption at the same wavelengths.

(2) Determine the infrared absorption spectrum of Ephedrine Hydrochloride, previously dried, as directed in the potassium chloride disk method under Infrared Spectrophotometry <2.25>, and compare the spectrum with the Reference Spectrum: both spectra exhibit similar intensities of absorption at the same wave numbers.

(3) A solution of Ephedrine Hydrochloride (1 in 15) responds to Qualitative Tests <1.09> for chloride.

Optical rotation <2.49> $[\alpha]_D^{20}$: $-33.0 - -36.0^\circ$ (after drying, 1 g, water, 20 mL, 100 mm).

pH <2.54> Dissolve 1.0 g of Ephedrine Hydrochloride in 20 mL of water: the pH of this solution is between 4.5 and 6.5.

Melting point <2.60> 218 – 222°C

Purity (1) Clarity and color of solution—Dissolve 0.5 g of Ephedrine Hydrochloride in 10 mL of water: the solution is clear and colorless.

(2) Sulfate—Dissolve 0.05 g of Ephedrine Hydrochloride in 40 mL of water, add 1 mL of dilute hydrochloric acid and 1 mL of barium chloride TS, and allow to stand for 10 minutes: no turbidity is produced.

(3) Heavy metals <1.07>—Proceed with 1.0 g of Ephedrine Hydrochloride according to Method 2, and perform the test. Prepare the control solution with 1.0 mL of Standard Lead Solution (not more than 10 ppm).

(4) Related substances—Dissolve 0.05 g of Ephedrine Hydrochloride in 50 mL of the mobile phase, and use this solution as the sample solution. Pipet 1 mL of the sample solution, add the mobile phase to make exactly 100 mL, and use this solution as the standard solution. Perform the test with exactly 10 μ L each of the sample solution and standard solution as directed under Liquid Chromatography <2.01> according to the following conditions, and determine the areas of each peak by the automatic integration method; the total area of the peaks other than ephedrine obtained from the sample solution is not larger than the peak area of ephedrine from the standard solution.

Operating conditions—

Detector: An ultraviolet absorption photometer (wavelength: 210 nm).

Column: A stainless steel column 4.6 mm in inside diameter and 15 cm in length, packed with octadecylsilanized silica gel for liquid chromatography (5 μ m in particle diameter).

Column temperature: A constant temperature of about 45°C.

Mobile phase: A mixture of a solution of sodium lauryl sulfate (1 in 128), acetonitrile and phosphoric acid (640:360:1).

Flow rate: Adjust so that the retention time of ephedrine is about 14 minutes.

Time span of measurement: About 3 times as long as the retention time of ephedrine, beginning after the solvent peak.

System suitability—

Test for required detectability: To exactly 1 mL of the standard solution add the mobile phase to make exactly 20 mL. Confirm that the peak area of ephedrine obtained with 10 μ L of this solution is equivalent to 4 to 6% of that with 10 μ L of the standard solution.

System performance: Dissolve 1 mg of ephedrine hydrochloride for assay and 4 mg of atropine sulfate hydrate in 100 mL of diluted methanol (1 in 2). When the procedure is run with 10 μ L of this solution under the above operating conditions, ephedrine and atropine are eluted in this order with the resolution between these peaks being not less than 1.5.

System repeatability: When the test is repeated 6 times with 10 μ L of the standard solution under the above operating conditions, the relative standard deviation of the peak areas of ephedrine is not more than 2.0%.

Loss on drying <2.41> Not more than 0.5% (1 g, 105°C, 3 hours).

Residue on ignition <2.44> Not more than 0.1% (1 g).

Assay Weigh accurately about 0.4 g of Ephedrine Hydrochloride, previously dried, and dissolve in 50 mL of a mixture of acetic anhydride and acetic acid (100) (7:3) by warming. Cool, and titrate <2.50> with 0.1 mol/L perchloric acid VS (potentiometric titration). Perform a blank determination in the same manner, and make any necessary correction.

Each mL of 0.1 mol/L perchloric acid VS
= 20.17 mg of $C_{10}H_{15}NO \cdot HCl$

Containers and storage Containers—Well-closed containers.

Ephedrine Hydrochloride Injection

エフェドリン塩酸塩注射液

Ephedrine Hydrochloride Injection is an aqueous injection.

It contains not less than 95.0% and not more than 105.0% of the labeled amount of ephedrine hydrochloride ($C_{10}H_{15}NO \cdot HCl$: 201.69).

Method of preparation Prepare as directed under Injections, with Ephedrine Hydrochloride.

Description Ephedrine Hydrochloride Injection is a clear, colorless liquid.

pH: 4.5 – 6.5

Identification To a volume of Ephedrine Hydrochloride Injection, equivalent to 0.05 g of Ephedrine Hydrochloride, add water to make 100 mL, and determine the absorption spectrum of this solution as directed under Ultraviolet-visible Spectrophotometry <2.24>: it exhibits maxima between 249 nm and 253 nm, between 255 nm and 259 nm, and between 261 nm and 265 nm.

Bacterial endotoxins <4.01> Less than 7.5 EU/mg.

Extractable volume <6.05> It meets the requirement.

Foreign insoluble matter <6.06> Perform the test according to Method 1: it meets the requirement.

Insoluble particulate matter <6.07> It meets the requirement.

Sterility <4.06> Perform the test according to the Membrane filtration method: it meets the requirement.

Assay To an exact volume of Ephedrine Hydrochloride Injection, equivalent to about 40 mg of ephedrine hydrochloride ($C_{10}H_{15}NO.HCl$), add exactly 10 mL of the internal standard solution and water to make 200 mL, and use this solution as the sample solution. Separately, weigh accurately about 40 mg of ephedrine hydrochloride for assay, previously dried at 105°C for 3 hours, add exactly 10 mL of the internal standard solution to dissolve, add water to make 200 mL, and use this solution as the standard solution. Perform the test with 10 μ L each of the sample solution and standard solution as directed under Liquid Chromatography <2.01> according to the following conditions, and calculate the ratios, Q_T and Q_S , of the peak area of ephedrine to that of the internal standard.

$$\text{Amount (mg) of ephedrine hydrochloride (C}_{10}\text{H}_{15}\text{NO.HCl)} = M_S \times Q_T/Q_S$$

M_S : Amount (mg) of ephedrine hydrochloride for assay taken

Internal standard solution—A solution of ephedrine hydrochloride (1 in 500).

Operating conditions—

Detector, column, column temperature, mobile phase, and flow rate: Proceed as directed in the operating conditions in the Purity (4) under Ephedrine Hydrochloride.

System suitability—

System performance: When the procedure is run with 10 μ L of the standard solution under the above operating conditions, the internal standard and ephedrine are eluted in this order with the resolution between these peaks being not less than 15.

System repeatability: When the test is repeated 6 times with 10 μ L of the standard solution under the above operating conditions, the relative standard deviation of the ratios of the peak area of ephedrine to that of the internal standard is not more than 1.0%.

Containers and storage Containers—Hermetic containers.

Storage—Light-resistant.

10% Ephedrine Hydrochloride Powder

エフェドリン塩酸塩散 10%

10% Ephedrine Hydrochloride Powder contains not less than 9.3% and not more than 10.7% of ephedrine hydrochloride ($C_{10}H_{15}NO.HCl$; 201.69).

Method of preparation

Ephedrine Hydrochloride	100 g
Starch, Lactose Hydrate or their mixture	a sufficient quantity
To make 1000 g	

Prepare as directed under Granules or Powders, with the above ingredients.

Identification To 0.5 g of 10% Ephedrine Hydrochloride Powder add 100 mL of water, shake for 20 minutes, and filter. Determine the absorption spectrum of the filtrate as directed under Ultraviolet-visible Spectrophotometry <2.24>: it exhibits maxima between 249 nm and 253 nm, between 255 nm and 259 nm, and between 261 nm and 265 nm.

Dissolution <6.10> When the test is performed at 50 revolutions per minute according to the Paddle method, using 900 mL of water as the dissolution medium, the dissolution rate in 15 minutes of 10% Ephedrine Hydrochloride Powder is not less than 85%.

Start the test with about 0.25 g of 10% Ephedrine Hydrochloride Powder, accurately weighed, withdraw not less than 20 mL of the medium at the specified minute after starting the test, and filter through a membrane filter with a pore size not exceeding 0.45 μ m. Discard not less than 10 mL of the first filtrate, and use the subsequent filtrate as the sample solution. Separately, weigh accurately about 28 mg of ephedrine hydrochloride for assay, previously dried at 105°C for 3 hours, and dissolve in water to make exactly 100 mL. Pipet 5 mL of this solution, add water to make exactly 50 mL, and use this solution as the standard solution. Perform the test with exactly 10 μ L each of the sample solution and standard solution as directed under Liquid Chromatography <2.01> according to the following conditions, and determine the peak areas, A_T and A_S , of ephedrine in each solution.

$$\text{Dissolution rate (\%)} \text{ with respect to the labeled amount of ephedrine hydrochloride (C}_{10}\text{H}_{15}\text{NO.HCl)} = M_S/M_T \times A_T/A_S \times 9/10$$

M_S : Amount (mg) of ephedrine hydrochloride for assay taken

M_T : Amount (g) of 10% Ephedrine Hydrochloride Powder taken

Operating conditions—

Detector, column, column temperature, mobile phase, and flow rate: Proceed as directed in the operating conditions in the Purity (4) under Ephedrine Hydrochloride.

System suitability—

System performance: When the procedure is run with 10 μ L of the standard solution under the above operating conditions, the number of theoretical plates and the symmetry factor of the peak of ephedrine are not less than 10,000 and not more than 2.0, respectively.

System repeatability: When the test is repeated 6 times with 10 μ L of the standard solution under the above operat-

ing conditions, the relative standard deviation of the peak area of ephedrine is not more than 2.0%.

Assay Weigh accurately about 0.4 g of 10% Ephedrine Hydrochloride Powder, add 150 mL of water, and extract by sonicating for 10 minutes with occasional shaking. Shake more for 10 minutes, then add exactly 10 mL of the internal standard solution and water to make 200 mL, centrifuge, and use the supernatant liquid as the sample solution. Separately, weigh accurately about 40 mg of ephedrine hydrochloride for assay, previously dried at 105°C for 3 hours, add exactly 10 mL of the internal standard solution to dissolve, add water to make 200 mL, and use this solution as the standard solution. Perform the test with 10 μ L each of the sample solution and standard solution as directed under Liquid Chromatography <2.01> according to the following conditions, and calculate the ratios, Q_T and Q_S , of the peak area of ephedrine to that of the internal standard.

Amount (mg) of ephedrine hydrochloride ($C_{10}H_{15}NO.HCl$)
 $= M_S \times Q_T / Q_S$

M_S : Amount (mg) of ephedrine hydrochloride for assay taken

Internal standard solution—A solution of ephedrine hydrochloride (1 in 500).

Operating conditions—

Detector, column, column temperature, mobile phase and flow rate: Perform as directed in the operating conditions in the Purity (4) under Ephedrine Hydrochloride.

System suitability—

System performance: When the procedure is run with 10 μ L of the standard solution under the above operating conditions, the internal standard and ephedrine are eluted in this order with the resolution between these peaks being not less than 15.

System repeatability: When the test is repeated 6 times with 10 μ L of the standard solution under the above operating conditions, the relative standard deviation of the ratios of the peak area of ephedrine to that of the internal standard is not more than 1.0%.

Containers and storage Containers—Well-closed containers.

Ephedrine Hydrochloride Tablets

エフェドリン塩酸塩錠

Ephedrine Hydrochloride Tablets contain not less than 93.0% and not more than 107.0% of the labeled amount of ephedrine hydrochloride ($C_{10}H_{15}NO.HCl$: 201.69).

Method of preparation Prepare as directed under Tablets, with Ephedrine Hydrochloride.

Identification To an amount of powdered Ephedrine Hydrochloride Tablets, equivalent to 0.05 g of Ephedrine Hydrochloride, add 100 mL of water, shake for 20 minutes, and filter. Determine the absorption spectrum of the filtrate as directed under Ultraviolet-visible Spectrophotometry <2.24>: it exhibits maxima between 249 nm and 253 nm, between 255 nm and 259 nm, and between 261 nm and 265 nm.

Uniformity of dosage units <6.02> Perform the test according to the following method: it meets the requirement of the Content uniformity test.

To 1 tablet of Ephedrine Hydrochloride Tablets add V mL of water so that each mL contains about 0.25 mg of ephedrine hydrochloride ($C_{10}H_{15}NO.HCl$), then add exactly $V/4$ mL of the internal standard solution, disperse the tablet into small particles by sonicating, then sonicate for a further 10 minutes. Shake this solution for 10 minutes, centrifuge, and use the supernatant liquid as the sample solution. Separately, weigh accurately about 25 mg of ephedrine hydrochloride for assay, previously dried at 105°C for 3 hours, dissolve in water to make exactly 100 mL. Pipet 20 mL of this solution, add exactly 5 mL of the internal standard solution, and use this solution as the standard solution. Then, proceed as directed in the Assay.

Amount (mg) of ephedrine hydrochloride ($C_{10}H_{15}NO.HCl$)
 $= M_S \times Q_T / Q_S \times V / 100$

M_S : Amount (mg) of ephedrine hydrochloride for assay taken

Internal standard solution—A solution of ephedrine hydrochloride (1 in 2000).

Dissolution <6.10> When the test is performed at 50 revolutions per minute according to the Paddle method, using 900 mL of water as the dissolution medium, the dissolution rate in 30 minutes of Ephedrine Hydrochloride Tablets is not less than 80%.

Start the test with 1 tablet of Ephedrine Hydrochloride Tablets, withdraw not less than 20 mL of the medium at the specified minute after starting the test, and filter through a membrane filter with a pore size not exceeding 0.45 μ m. Discard not less than 10 mL of the first filtrate, and use the subsequent filtrate as the sample solution. Separately, weigh accurately about 28 mg of ephedrine hydrochloride for assay, previously dried at 105°C for 3 hours, and dissolve in water to make exactly 100 mL. Pipet 5 mL of this solution, add water to make exactly 50 mL, and use this solution as the standard solution. Perform the test with exactly 10 μ L each of the sample solution and standard solution as directed under Liquid Chromatography <2.01> according to the following conditions, and determine the peak areas, A_T and A_S , of ephedrine in each solution.

Dissolution rate (%) with respect to the labeled amount of ephedrine hydrochloride ($C_{10}H_{15}NO.HCl$)
 $= M_S \times A_T / A_S \times 1 / C \times 90$

M_S : Amount (mg) of ephedrine hydrochloride for assay taken

C : Labeled amount (mg) of ephedrine hydrochloride ($C_{10}H_{15}NO.HCl$) in 1 tablet

Operating conditions—

Detector, column, column temperature, mobile phase and flow rate: Proceed as directed in the operating conditions in the Purity (4) under Ephedrine Hydrochloride.

System suitability—

System performance: When the procedure is run with 10 μ L of the standard solution under the above operating conditions, the number of theoretical plates and the symmetry factor of the peak of ephedrine are not less than 10,000 and not more than 2.0, respectively.

System repeatability: When the test is repeated 6 times with 10 μ L of the standard solution under the above operating conditions, the relative standard deviation of the peak area of ephedrine is not more than 2.0%.

Assay Weigh accurately not less than 20 tablets of Ephedrine Hydrochloride Tablets, and powder. Weigh accurately an amount of the powder, equivalent to about 40 mg of

ephedrine hydrochloride ($C_{10}H_{15}NO.HCl$), add 150 mL of water, and extract by sonicating for 10 minutes with occasional shaking. Shake more for 10 minutes, then add exactly 10 mL of the internal standard solution and water to make 200 mL, centrifuge, and use the supernatant liquid as the sample solution. Separately, weigh accurately about 40 mg of ephedrine hydrochloride for assay, previously dried at 105°C for 3 hours, add exactly 10 mL of the internal standard solution to dissolve, add water to make 200 mL, and use this solution as the standard solution. Perform the test with 10 μ L each of the sample solution and standard solution as directed under Liquid Chromatography <2.01> according to the following conditions, and calculate the ratios, Q_T and Q_S , of the peak area of ephedrine to that of the internal standard.

$$\text{Amount (mg) of ephedrine hydrochloride (C}_{10}\text{H}_{15}\text{NO.HCl)} \\ = M_S \times Q_T/Q_S$$

M_S : Amount (mg) of ephedrine hydrochloride for assay taken

Internal standard solution—A solution of ephedrine hydrochloride (1 in 500).

Operating conditions—

Detector, column, column temperature, mobile phase, and flow rate: Proceed as directed in the operating conditions in the Purity (4) under Ephedrine Hydrochloride.

System suitability—

System performance: When the procedure is run with 10 μ L of the standard solution under the above operating conditions, the internal standard and ephedrine are eluted in this order with the resolution between these peaks being not less than 15.

System repeatability: When the test is repeated 6 times with 10 μ L of the standard solution under the above operating conditions, the relative standard deviation of the ratios of the peak area of ephedrine to that of the internal standard is not more than 1.0%.

Containers and storage Containers—Well-closed containers.

Epirizole

エピリゾール

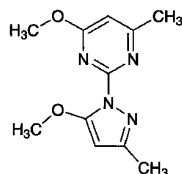

$C_{11}H_{14}N_4O_2$: 234.25

4-Methoxy-2-(5-methoxy-3-methyl-1H-pyrazol-1-yl)-6-methylpyrimidine
[18694-40-1]

Epirizole, when dried, contains not less than 99.0% of epirizole ($C_{11}H_{14}N_4O_2$).

Description Epirizole occurs as white, crystals or crystalline powder. It is odorless, and has a bitter taste.

It is very soluble in methanol and in acetic acid (100), freely soluble in ethanol (95), and sparingly soluble in water and in diethyl ether.

It dissolves in dilute hydrochloric acid and in sulfuric acid. The pH of a solution of 1.0 g of Epirizole in 100 mL of

water is between 6.0 and 7.0.

Identification (1) To 0.1 g of Epirizole add 0.1 g of vanillin, 5 mL of water and 2 mL of sulfuric acid, and mix with shaking for a while: a yellow precipitate is formed.

(2) Dissolve 0.1 g of Epirizole in 10 mL of water, and add 10 mL of 2,4,6-trinitrophenol TS: a yellow precipitate is produced. Collect the precipitate by filtration, wash with 50 mL of water, and dry at 105°C for 1 hour: it melts <2.60> between 163°C and 169°C.

(3) Determine the absorption spectrum of a solution of Epirizole in 0.1 mol/L hydrochloric acid TS (1 in 200,000) as directed under Ultraviolet-visible Spectrophotometry <2.24>, and compare the spectrum with the Reference Spectrum: both spectra exhibit similar intensities of absorption at the same wavelengths.

Melting point <2.60> 88 – 91°C

Purity (1) Clarity and color of solution—Dissolve 0.20 g of Epirizole in 20 mL of water: the solution is clear and colorless.

(2) Chloride <1.03>—Add 0.5 g of Epirizole to a ground mixture of 0.7 g of potassium nitrate and 1.2 g of anhydrous sodium carbonate, mix well, transfer little by little to a platinum crucible, previously heated, and heat until the reaction is completed. After cooling, add 15 mL of dilute sulfuric acid and 5 mL of water to the residue, boil for 5 minutes, filter, wash the insoluble matter with 10 mL of water, and to the combined filtrate and washings add 6 mL of dilute nitric acid and water to make 50 mL. Perform the test with this solution as the test solution. Prepare the control solution as follows: proceed with the same quantities of the same reagents as directed for the preparation of the test solution, and add 0.25 mL of 0.01 mol/L hydrochloric acid VS and water to make 50 mL (not more than 0.018%).

(3) Heavy metals <1.07>—Proceed with 2.0 g of Epirizole according to Method 2, and perform the test. Prepare the control solution with 2.0 mL of Standard Lead Solution (not more than 10 ppm).

(4) Arsenic <1.11>—Prepare the test solution with 1.0 g of Epirizole according to Method 3, and perform the test (not more than 2 ppm).

(5) Related substances—Dissolve 1.0 g of Epirizole in 10 mL of methanol, and use this solution as the sample solution. Pipet 1 mL of the sample solution, and add methanol to make exactly 50 mL. Pipet 1 mL of this solution, add methanol to make exactly 10 mL, and use this solution as the standard solution. Perform the test with these solutions as directed under Thin-layer Chromatography <2.03>. Spot 2 μ L each of the sample solution and standard solution on a plate of silica gel with fluorescent indicator for thin-layer chromatography. Develop the plate with a mixture of isopropyl ether, ethanol (95) and water (23:10:2) to a distance of about 10 cm, and air-dry the plate. Examine under ultraviolet light (main wavelength: 254 nm): the spots other than the principal spot obtained from the sample solution are not more intense than the spot from the standard solution. Place this plate in a chamber filled with iodine vapor: the spots other than the principal spot from the sample solution are not more intense than the spot from the standard solution.

(6) Readily carbonizable substances <1.15>—Perform the test with 0.10 g of Epirizole: the solution has no more color than Matching Fluid A.

Loss on drying <2.41> Not more than 0.5% (1 g, silica gel, 4 hours).

Residue on ignition <2.44> Not more than 0.1% (1 g).

Assay Weigh accurately about 0.5 g of Epirizole, previously dried, dissolve in 40 mL of acetic acid (100) and titrate <2.50> with 0.1 mol/L perchloric acid VS (indicator: 2 drops of crystal violet TS) until the color of the solution changes from purple through blue-green to green.

Perform a blank determination in the same manner, and make any necessary correction.

$$\begin{aligned} \text{Each mL of 0.1 mol/L perchloric acid VS} \\ = 23.43 \text{ mg of } C_{11}H_{14}N_4O_2 \end{aligned}$$

Containers and storage Containers—Well-closed containers.

Epirubicin Hydrochloride

エピルビシン塩酸塩

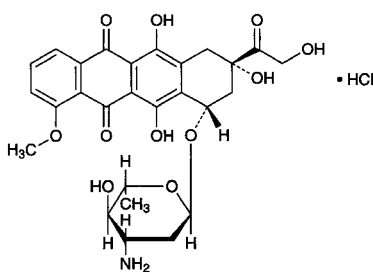

$C_{27}H_{29}NO_{11} \cdot HCl$: 579.98
(2*S*,4*S*)-4-(3-Amino-2,3,6-trideoxy- α -L-arabino-hexopyranosyloxy)-2,5,12-trihydroxy-2-hydroxyacetyl-7-methoxy-1,2,3,4-tetrahydrotetracene-6,11-dione monohydrochloride
[56390-09-1]

Epirubicin Hydrochloride is the hydrochloride of a derivative of daunorubicin.

It contains not less than 970 μ g (potency) and not more than 1020 μ g (potency) per mg, calculated on the anhydrous and residual solvent-free basis. The potency of Epirubicin Hydrochloride is expressed as mass (potency) of epirubicin hydrochloride ($C_{27}H_{29}NO_{11} \cdot HCl$).

Description Epirubicin Hydrochloride occurs as a pale yellowish red to brownish red powder.

It is soluble in water and in methanol, slightly soluble in ethanol (95), and practically insoluble in acetonitrile.

It is hygroscopic.

Identification (1) Determine the absorption spectrum of a solution of Epirubicin Hydrochloride in methanol (3 in 200,000) as directed under Ultraviolet-visible Spectrophotometry <2.24>, and compare the spectrum with the Reference Spectrum: both spectra exhibit similar intensities of absorption at the same wavelengths.

(2) Determine the infrared absorption spectrum of Epirubicin Hydrochloride and Epirubicin Hydrochloride RS as directed in the potassium bromide disk method under Infrared Spectrophotometry <2.25>, and compare these spectra: both spectra exhibit similar intensities of absorption at the same wave numbers.

Optical rotation <2.49> $[\alpha]_D^{20}$: +310 – +340° (10 mg calculated on the anhydrous and residual solvent-free basis, methanol, 20 mL, 100 mm).

pH <2.54> Dissolve 10 mg of Epirubicin Hydrochloride in 2

mL of water: the pH of the solution is between 4.0 and 5.5.

Purity (1) Clarity and color of solution—Dissolve 50 mg of Epirubicin Hydrochloride in 5 mL of water: the solution is clear and dark red.

(2) Heavy metals <1.07>—Proceed with 1.0 g of Epirubicin Hydrochloride according to Method 2, and perform the test. Prepare the control solution with 2.0 mL of Standard Lead Solution (not more than 20 ppm).

(3) Related substances—Perform the test with 10 μ L of the sample solution obtained in the Assay as directed under Liquid Chromatography <2.01> according to the following conditions, determine each peak area by the automatic integration method, and calculate the total amount of the peaks other than epirubicin and 2-naphthalenesulfonic acid by the area percentage method: not more than 5.0%.

Operating conditions—

Detector, column, column temperature, mobile phase, and flow rate: Proceed as directed in the operating conditions in the Assay.

Time span of measurement: About 3 times as long as the retention time of epirubicin, beginning after the solvent peak.

System suitability—

System performance, and system repeatability: Proceed as directed in the system suitability in the Assay.

Test for required detectability: To 1 mL of the sample solution add the mobile phase to make 100 mL, and use this solution as the solution for system suitability test. Pipet 1 mL of the solution for system suitability test, and add the mobile phase to make exactly 10 mL. Confirm that the peak area of epirubicin obtained with 10 μ L of this solution is equivalent to 7 to 13% of that with 10 μ L of the solution for system suitability test.

Water <2.48> Not more than 8.0% (0.1 g, volumetric titration, direct titration).

Residue on ignition <2.44> Not more than 0.5% (0.1 g).

Assay Weigh accurately an amount of Epirubicin Hydrochloride and Epirubicin Hydrochloride RS, equivalent to about 50 mg (potency), dissolve each in the internal standard solution to make exactly 50 mL, and use these solutions as the sample solution and the standard solution, respectively. Perform the test with 10 μ L each of the sample solution and standard solution as directed under Liquid Chromatography <2.01> according to the following conditions, and calculate the ratios, Q_T and Q_S , of the peak area of epirubicin to that of the internal standard.

$$\begin{aligned} \text{Amount } [\mu\text{g (potency)}] \text{ of epirubicin hydrochloride} \\ (C_{27}H_{29}NO_{11} \cdot HCl) \\ = M_S \times Q_T / Q_S \times 1000 \end{aligned}$$

M_S : Amount [mg (potency)] of Epirubicin Hydrochloride RS taken

Internal standard solution—A solution of sodium 2-naphthalene sulfonate in a mixture of water, acetonitrile, methanol and phosphoric acid (540:290:170:1) (1 in 2000).

Operating conditions—

Detector: An ultraviolet absorption photometer (wavelength: 254 nm).

Column: A stainless steel column 4 mm in inside diameter and 25 cm in length, packed with trimethylsilanized silica gel for liquid chromatography (6 μ m in particle diameter).

Column temperature: A constant temperature of about 35°C.

Mobile phase: Dissolve 2 g of sodium lauryl sulfate in a

mixture of water, acetonitrile, methanol and phosphoric acid (540:290:170:1) to make 1000 mL.

Flow rate: Adjust so that the retention time of eplerubicin is about 9.5 minutes.

System suitability—

System performance: When the procedure is run with 10 μ L of the standard solution under the above operating conditions, the internal standard and eplerubicin are eluted in this order with the resolution between these peaks being not less than 20.

System repeatability: When the test is repeated 5 times with 10 μ L of the standard solution under the above operating conditions, the relative standard deviation of the ratios of the peak area of eplerubicin to that of the internal standard is not more than 1.0%.

Containers and storage Containers—Tight containers.

Storage—At a temperature between 0°C and 5°C.

Eplerenone

エプレレノン

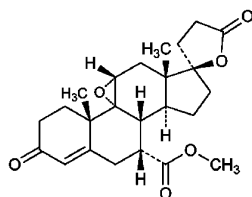

$C_{24}H_{30}O_6$: 414.49

9,11 α -Epoxy-7 α -(methoxycarbonyl)-3-oxo-17 α -pregn-4-ene-21,17-carbolactone
[107724-20-9]

Eplerenone contains not less than 98.0% and not more than 102.0% of eplerenone ($C_{24}H_{30}O_6$), calculated on the dried basis.

Description Eplerenone occurs as a white crystalline powder.

It is freely soluble in acetonitrile, sparingly soluble in methanol, and very slightly soluble in water and in ethanol (99.5).

It shows crystal polymorphism.

Identification (1) Determine the absorption spectrum of a solution of Eplerenone in methanol (1 in 77,000) as directed under Ultraviolet-visible Spectrophotometry <2.24>, and compare the spectrum with the Reference Spectrum or the spectrum of a solution of Eplerenone RS prepared in the same manner as the sample solution: both spectra exhibit similar intensities of absorption at the same wavelengths.

(2) Determine the infrared absorption spectrum of Eplerenone as directed in the potassium bromide disk method under Infrared Spectrophotometry <2.25>, and compare the spectrum with the Reference Spectrum or the spectrum of Eplerenone RS: both spectra exhibit similar intensities of absorption at the same wave numbers.

Optical rotation <2.49> $[\alpha]_D^{20}$: $-14.0 - -16.0^\circ$ (0.25 g calculated on the dried basis, acetonitrile, 25 mL, 100 mm).

Purity (1) Heavy metals—Take 1.0 g of Eplerenone in a crucible, wet the sample with a suitable amount of sulfuric acid, cover loosely, and heat gently to carbonize. After cooling, add 2 mL of nitric acid, and 5 drops of sulfuric acid to the carbonized residue, and heat gently until white fumes are

no longer evolved. Then, incinerate by ignition at 500–600°C. After cooling, add 4 mL of 6 mol/L hydrochloric acid TS, cover the crucible, warm on a water bath for 15 minutes, then remove the cover from the crucible, and slowly evaporate to dryness on a water bath. Wet the residue with 1 drop of hydrochloric acid, add 10 mL of hot water, and warm for 2 minutes. After cooling, add ammonia TS until the solution shows alkalinity to litmus paper, add 15 mL of water, and adjust to pH 3.0–4.0 with dilute acetic acid. Filter, if necessary, wash the crucible and filter paper with 10 mL of water, put the filtrate and the washings in a Nessler tube, add water to make 40 mL, and use this solution as the sample solution. Separately, take 2.0 mL of Standard Lead Solution in a Nessler tube, and add water to make 25 mL. Adjust to pH 3.0–4.0 of this solution with dilute acetic acid or ammonia TS, add water to make 40 mL, and use this solution as the control solution. To the sample solution and the control solution add 2 mL of acetate buffer solution (pH 3.5) and 1.2 mL of thioacetamide-alkaline glycerin TS, then add water to make 50 mL, allow them to stand for 2 minutes, and observe vertically against a white background: the solution obtained from the sample solution is not more colored than that obtained from the control solution (not more than 20 ppm).

(2) Related substances—Dissolve 25 mg of Eplerenone in 50 mL of the mobile phase, and use this solution as the sample solution. Pipet 1 mL of the sample solution, add the mobile phase to make exactly 100 mL, and use this solution as the standard solution. Perform the test with exactly 20 μ L each of the sample solution and standard solution as directed under Liquid Chromatography <2.01> according to the following conditions, and determine each peak area by the automatic integration method: the area of the peak, having a relative retention time of about 0.58, about 0.85, about 0.90, about 1.2 and about 1.6 to eplerenone, obtained from the sample solution is respectively not larger than 1/5, 3/10, 3/10, 3/10 and 3/10 times the peak area of eplerenone from the standard solution, and the area of the peak other than eplerenone and the peak mentioned above from the sample solution is not larger than 7/50 times the peak area of eplerenone from the standard solution. Furthermore, the total area of the peaks other than eplerenone from the sample solution is not larger than 1.2 times the peak area of eplerenone from the standard solution. For the area of the peak, having the relative retention time of about 0.85 to eplerenone, multiply the correction factor 0.6.

Operating conditions—

Detector, column, column temperature, mobile phase, and flow rate: Proceed as directed in the operating conditions in the Assay.

Time span of measurement: About 4 times as long as the retention time of eplerenone, beginning after the solvent peak.

System suitability—

Test for required detectability: Pipet 1 mL of the standard solution, add the mobile phase to make exactly 10 mL. Confirm that the peak area of eplerenone obtained with 20 μ L of this solution is equivalent to 7 to 13% of that with 20 μ L of the standard solution.

System performance: When the procedure is run with 20 μ L of the standard solution under the above operating conditions, the number of theoretical plates and the symmetry factor of the peak of eplerenone are not less than 15,000 and not more than 1.5, respectively.

System repeatability: When the test is repeated 6 times with 20 μ L of the standard solution under the above operating conditions, the relative standard deviation of the peak

area of eplerenone is not more than 2.0%.

Loss on drying <2.41> Not more than 0.5% (0.5 g, 105°C, 4 hours).

Residue on ignition <2.44> Not more than 0.1% (1 g).

Assay Weigh accurately about 25 mg each of Eplerenone and Eplerenone RS (separately determine the loss on drying <2.41> under the same conditions as Eplerenone), separately dissolve in the mobile phase to make exactly 50 mL, and use these solutions as the sample solution and the standard solution, respectively. Perform the test with exactly 20 μ L each of the sample solution and standard solution as directed under Liquid Chromatography <2.01> according to the following conditions, and determine the peak areas, A_T and A_S , of eplerenone in each solution.

$$\text{Amount (mg) of eplerenone (C}_{24}\text{H}_{30}\text{O}_6) = M_S \times A_T/A_S$$

M_S : Amount (mg) of Eplerenone RS taken, calculated on the dried basis

Operating conditions—

Detector: An ultraviolet absorption photometer (wavelength: 210 nm).

Column: A stainless steel column 4.6 mm in inside diameter and 25 cm in length, packed with octadecylsilanized silica gel for liquid chromatography (5 μ m in particle diameter).

Column temperature: A constant temperature of about 35°C.

Mobile phase: Dissolve 1.4 g of potassium dihydrogen phosphate in 1000 mL of water, and adjust to pH 3.0 with phosphoric acid. To 580 mL of this solution add 360 mL of acetonitrile for liquid chromatography and 60 mL of methanol.

Flow rate: Adjust so that the retention time of eplerenone is about 12 minutes.

System suitability—

System performance: When the procedure is run with 20 μ L of the standard solution under the above operating conditions, the number of theoretical plates and the symmetry factor of the peak of eplerenone are not less than 15,000 and not more than 1.5, respectively.

System repeatability: When the test is repeated 6 times with 20 μ L of the standard solution under the above operating conditions, the relative standard deviation of the peak area of eplerenone is not more than 1.0%.

Containers and storage Containers—Well-closed containers.

Eplerenone Tablets

エプレレノン錠

Eplerenone Tablets contain not less than 95.0% and not more than 105.0% of the labeled amount of eplerenone (C₂₄H₃₀O₆; 414.49).

Method of preparation Prepare as directed under Tablets, with Eplerenone.

Identification Determine the absorption spectrum of the sample solution obtained in the Uniformity of dosage units as directed under Ultraviolet-visible Spectrophotometry <2.24>: it exhibits a maximum between 240 nm and 244 nm.

Uniformity of dosage units <6.02> Perform the Mass variation test, or the Content uniformity test according to the fol-

lowing method: it meets the requirement.

To 1 tablet of Eplerenone Tablets add a suitable amount of a mixture of acetonitrile and water (3:2), shake, disintegrate the tablet by sonicating, add a mixture of acetonitrile and water (3:2) to make exactly 100 mL, and centrifuge. Take exactly V mL of the supernatant liquid, add a mixture of acetonitrile and water (3:2) to make exactly V' mL so that each mL contains about 25 μ g of eplerenone (C₂₄H₃₀O₆), and use this solution as the sample solution. Separately, weigh accurately about 25 mg of Eplerenone RS (separately determine the loss on drying <2.41> under the same conditions as Eplerenone), and dissolve in a mixture of acetonitrile and water (3:2) to make exactly 50 mL. Pipet 5 mL of this solution, add a mixture of acetonitrile and water (3:2) to make exactly 100 mL, and use this solution as the standard solution. Determine the absorbances, A_T and A_S , at 243 nm of the sample solution and standard solution as directed under Ultraviolet-visible Spectrophotometry <2.24>.

$$\begin{aligned} \text{Amount (mg) of eplerenone (C}_{24}\text{H}_{30}\text{O}_6) \\ = M_S \times A_T/A_S \times V'/V \times 1/10 \end{aligned}$$

M_S : Amount (mg) of Eplerenone RS taken, calculated on the dried basis

Dissolution <6.10> When the test is performed at 50 revolutions per minute according to the Paddle method, using 900 mL of 1st fluid for dissolution test as the dissolution medium, the dissolution rate in 30 minutes of Eplerenone Tablets is not less than 75%.

Start the test with 1 tablet of Eplerenone Tablets, withdraw not less than 20 mL of the medium at the specified minute after starting the test, and filter through a membrane filter with a pore size not exceeding 0.45 μ m. Discard not less than 5 mL of the first filtrate, pipet V mL of the subsequent filtrate, add the dissolution medium to make exactly V' mL so that each mL contains about 11 μ g of eplerenone (C₂₄H₃₀O₆), and use this solution as the sample solution. Separately, weigh accurately about 25 mg of Eplerenone RS (separately determine the loss on drying <2.41> under the same conditions as Eplerenone), dissolve in 5 mL of acetonitrile, and add the dissolution medium to make exactly 500 mL. Pipet 10 mL of this solution, add the dissolution medium to make exactly 50 mL, and use this solution as the standard solution. Determine the absorbances, A_T and A_S , at 243 nm of the sample solution and standard solution as directed under Ultraviolet-visible Spectrophotometry <2.24> using the dissolution medium as the blank.

$$\begin{aligned} \text{Dissolution rate (\%)} \text{ with respect to the labeled amount} \\ \text{of eplerenone (C}_{24}\text{H}_{30}\text{O}_6) \\ = M_S \times A_T/A_S \times V'/V \times 1/C \times 36 \end{aligned}$$

M_S : Amount (mg) of Eplerenone RS taken, calculated on the dried basis

C : Labeled amount (mg) of eplerenone (C₂₄H₃₀O₆) in 1 tablet

Assay Weigh accurately the mass of not less than 20 Eplerenone Tablets, and powder. Weigh accurately a portion of the powder, equivalent to about 50 mg of eplerenone (C₂₄H₃₀O₆), add a suitable amount of a mixture of acetonitrile and water (3:2), sonicate to disperse the particles, and add a mixture of acetonitrile and water (3:2) to make exactly 100 mL. Centrifuge this solution, and use the supernatant liquid as the sample solution. Separately, weigh accurately about 25 mg of Eplerenone RS (separately determine the loss on drying <2.41> under the same conditions as Eplerenone), dissolve in a mixture of acetonitrile and water (3:2) to make exactly 50 mL, and use this solution as the standard solution.

Perform the test with exactly 15 μL each of the sample solution and standard solution as directed under Liquid Chromatography <2.01> according to the following conditions, and determine the peak areas, A_T and A_S , of eplerenone in each solution.

$$\begin{aligned} & \text{Amount (mg) of eplerenone (C}_{24}\text{H}_{30}\text{O}_6\text{)} \\ & = M_S \times A_T / A_S \times 2 \end{aligned}$$

M_S : Amount (mg) of Eplerenone RS taken, calculated on the dried basis

Operating conditions—

Detector: An ultraviolet absorption photometer (wavelength: 243 nm).

Column: A stainless steel column 4.6 mm in inside diameter and 15 cm in length, packed with octadecylsilanized silica gel for liquid chromatography (4 μm in particle diameter).

Column temperature: A constant temperature of about 25°C.

Mobile phase: Dissolve 1.4 g of potassium dihydrogen phosphate in 1000 mL of water, and adjust to pH 3.0 with phosphoric acid. To 550 mL of this solution add 360 mL of methanol and 90 mL of acetonitrile.

Flow rate: Adjust so that the retention time of eplerenone is about 12 minutes.

System suitability—

System performance: When the procedure is run with 15 μL of the standard solution under the above operating conditions, the number of theoretical plates and the symmetry factor of the peak of eplerenone are not less than 3000 and not more than 2.0, respectively.

System repeatability: When the test is repeated 6 times with 15 μL of the standard solution under the above operating conditions, the relative standard deviation of the peak area of eplerenone is not more than 1.0%.

Containers and storage Containers—Well-closed containers.

Epoetin Alfa (Genetical Recombination)

エポエチン アルファ (遺伝子組換え)

Protein moiety

```

APPRLICDSR VLERYLLEAK EAENITTGCA EHC SLNENIT VPDTKVNFYA
WKRMEVGGQA VEVWQGLALL SEAVLRGQAL LVNSSQPWEP LQLHVDRKAVS
GLRSLTTLRLR ALGAQKEAIS PPDAAASAAPL RTITADTFRK LFRVYSNFLR
GKCLKYTGEA CRTGD
  
```

N24, N38, N83 and S126: glycosylation

Carbohydrate moiety (structure of major glycans)

N24, N38 and N83

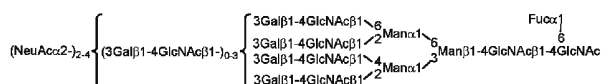

S126

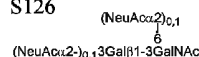

$\text{C}_{809}\text{H}_{1301}\text{N}_{229}\text{O}_{240}\text{S}_5$: 18235.70 (Protein moiety)
[113427-24-0]

Epoetin Alfa (Genetical Recombination) is an aqueous solution in which a desired product is a recombinant human erythropoietin produced in Chinese hamster ovary cells. It is a glycoprotein (molecular mass: ca. 37,000 to 42,000) consisting of 165 amino acid residues.

It contains not less than 1.1 mg and not more than 1.5 mg of protein per mL, and not less than 1.5×10^5 units per mg of protein.

Description Epoetin Alfa (Genetical Recombination) occurs as a clear and colorless liquid.

Identification (1) Dilute a suitable volume of Epoetin Alfa (Genetical Recombination) and Epoetin Alfa RS with water. To 3 volume of these solutions add 1 volume each of buffer solution for epoetin alfa sample, heat at 100°C for 5 minutes, and use these solutions as the sample solution and the standard solution, respectively. Transfer a volume of the sample solution and the standard solution, equivalent to 0.7 μg of protein, into each sample well of the polyacrylamide gel for epoetin alfa, and start the SDS-polyacrylamide gel electrophoresis using a vertical discontinuous buffer solution system. After the electrophoresis, immerse the gel, a polyvinylidene fluoride membrane and a filter paper in the blotting TS. Set them on a semi-dry blotting apparatus, and transcribe for about 1 hour with a constant electric current of 0.7–0.9 mA/cm² depending on the dimension of the filter paper. Then, immerse the polyvinylidene fluoride membrane in the blocking TS for epoetin alfa for more than 1 hour while shaking, remove the blocking TS for epoetin alfa and add the primary antibody TS, then shake for a night or allow to stand at 4°C for 3 nights. Remove the primary antibody TS, wash the membrane with phosphate-buffered sodium chloride TS, add the secondary antibody TS, and shake for more than 1 hour. Remove the secondary antibody TS, wash the membrane with phosphate-buffered sodium chloride TS, add the avidin-biotin TS, and shake for more than 1 hour. Remove the avidin-biotin TS, wash the mem-

brane with phosphate-buffered sodium chloride TS, and add the substrate TS for epoetin alfa for developing the color image: the main stained bands obtained from the sample solution appear as similar migrating image as those from the standard solution.

(2) Evaporate to dryness under reduced pressure a volume of Epoetin Alfa (Genetical Recombination) and Epoetin Alfa RS, equivalent to about 35 µg of protein, and dissolve these residues in 100 µL of 0.1 mol/L tris buffer solution (pH 7.3). To these solutions add 5 µL of trypsin TS for epoetin alfa, warm at 37°C for 6 hours, then cool in ice, and use these solutions as the sample solution and the standard solution, respectively. Perform the test with 45 µL each of the sample solution and standard solution as directed under Liquid Chromatography <2.01> according to the following conditions, and compare the chromatograms obtained from these solutions: both chromatograms show the similar peaks at the corresponding retention time.

Operating conditions—

Detector: An ultraviolet absorption photometer (wavelength: 214 nm).

Column: A stainless steel column 3.9 mm in inside diameter and 15 cm in length, packed with octylsilylated silica gel for liquid chromatography (5 µm in particle diameter).

Column temperature: A constant temperature of about 45°C.

Mobile phase A: A mixture of water and trifluoroacetic acid (5000:3).

Mobile phase B: A mixture of acetonitrile, water and trifluoroacetic acid (4000:1000:3).

Flowing of mobile phase: Control the gradient by mixing the mobile phases A and B as directed in the following table.

Time after injection of sample (min)	Mobile phase A (vol%)	Mobile phase B (vol%)
0 – 5	98	2
5 – 95	98 → 35	2 → 65

Flow rate: 0.75 mL per minute.

System suitability—

System performance: When the procedure is run with 45 µL of the standard solution under the above conditions, the chromatogram shows the similar pattern with the chromatogram of Epoetin Alfa RS obtained in the Peptide mapping.

Sialic acid content To an exact volume of Epoetin Alfa (Genetical Recombination), equivalent to about 1 nmol of protein, add water to make exactly 45 µL. Add exactly 5 µL of sodium hydroxide TS, allow to stand in ice water for 90 minutes, and add exactly 5 µL of dilute acetic acid. Add exactly 45 µL of water and exactly 100 µL of a mixture of water and acetic acid (100) (27:8), and warm at 80°C for 210 minutes. After cooling, add exactly 200 µL of the fluorescence TS, and warm at 60°C for 2 hours avoiding exposure to light. After cooling, add exactly 200 µL of sodium hydroxide TS, and use this solution as the sample solution. Separately, just before starting the test, to exactly 250 µL of 0.4 mmol/L *N*-acetylneuraminic acid TS add exactly 20 µL of 0.1 mmol/L *N*-glycolylneuraminic acid TS and exactly 180 µL of water. Proceed with exactly 45 µL of this solution in the same manner as for the sample solution, and use the solution so obtained as the standard solution. Perform the test with exactly 20 µL each of the sample solution and standard solution as directed under Liquid Chromatography <2.01> according to the following conditions, determine the peak areas of *N*-acetylneuraminic acid and *N*-glycolylneuraminic acid, A_{T1} and A_{T2} , obtained from the sample solution, and the peak areas of those, A_{S1} and A_{S2} , from the standard solution. Calculate the content of sialic acid in Epoetin Alfa (Genetical Recombination) by the following equation: between 10 mol/mol and 12 mol/mol.

Content (mol/mol) of sialic acid

$$= (A_{T1}/A_{S1} \times 10 + A_{T2}/A_{S2} \times 1/5)/a$$

a : Number (nmol) of moles of Epoetin Alfa (Genetical Recombination)

where, molar concentration (mmol/L) of Epoetin Alfa (Genetical Recombination) is calculated by the following equation, using the absorbance A at 280 nm obtained in the Assay (1).

Molar concentration (mmol/L) of Epoetin Alfa (Genetical Recombination)

$$= A \times 10^3/22,430$$

22,430: Molar absorbance coefficient ϵ

Operating conditions—

Detector: A fluorophotometer (excitation wavelength: 373 nm, fluorescence wavelength: 448 nm).

Column: A stainless steel column 3.9 mm in inside diameter and 15 cm in length, packed with octadecylsilylated silica gel for liquid chromatography (5 µm in particle diameter).

Column temperature: A constant temperature of about 25°C.

Mobile phase A: A mixture of water, acetonitrile and methanol (84:9:7).

Mobile phase B: A mixture of water and methanol (1:1).

Flowing of mobile phase: Control the gradient by mixing the mobile phases A and B as directed in the following table.

Time after injection of sample (min)	Mobile phase A (vol%)	Mobile phase B (vol%)
0 – 20	100	0
20 – 20.1	100 → 0	0 → 100
20.1 – 27	0	100

Flow rate: 0.6 mL per minute.

System suitability—

System performance: When the procedure is run with 20 µL of the standard solution under the above operating conditions, *N*-glycolylneuraminic acid and *N*-acetylneuraminic acid are eluted in this order with the resolution between these peaks being not less than 3.

System repeatability: When the test is repeated 6 times with 20 µL of the standard solution under the above operating conditions, the relative standard deviations of the peak area of *N*-glycolylneuraminic acid and *N*-acetylneuraminic acid are not more than 2.0%, respectively.

Oligosaccharide profile Being specified separately when the drug is granted approval based on the Law.

Molecular mass Use the sample solution obtained in the Identification (1) as the sample solution. Separately, to 20 µL of molecular mass standard stock solution add 6.7 µL of the buffer solution for epoetin alfa sample, heat at 100°C for 5 minutes, and use this solution as the molecular mass standard solution. Transfer a volume of the sample solution, equivalent to 3.5 µg of protein and the total volume of the molecular mass standard solution into each sample well of the vertical discontinuous buffer solution system SDS-polyacrylamide gel, composed with resolving and stacking

gels, and perform the electrophoresis. After the electrophoresis, immerse the gel in a solution of Coomassie brilliant blue R-250, containing 1.25 g in a mixture of 450 mL of methanol, 100 mL of acetic acid (100) and sufficient amount of water making up to 1000 mL. Determine the relative mobilities of the stained bands of egg albumin (molecular mass: about 45,000), carbonic anhydrase (molecular mass: about 31,000), soybean trypsin inhibitor (molecular mass: about 21,500) and lysozyme (molecular mass: 14,400), and prepare a calibration curve by linear regression against the logarithm of the molecular masses. Determine the relative mobility of the center of the main band obtained from the sample solution, and calculate the molecular mass of Epoetin Alfa (Genetical Recombination) from the calibration curve: it is between 37,000 and 42,000.

pH <2.54> 5.7 – 6.7

Purity (1) Multimers—Perform the test with a volume of Epoetin Alfa (Genetical Recombination), equivalent to 50 μ g of protein, as directed under Liquid Chromatography <2.01> according to the following conditions. Determine each peak area by the automatic integration method, and calculate their amounts by the area percentage method: the total amount of the peaks other than epoetin alfa is not more than 2%.

Operating conditions—

Detector: An ultraviolet absorption photometer (wavelength: 215 nm).

Column: A stainless steel column 7.5 mm in inside diameter and 60 cm in length, packed with hydrophilic silica gel for liquid chromatography.

Column temperature: A constant temperature of about 25°C.

Mobile phase: Dissolve 91 mg of disodium hydrogen phosphate dodecahydrate, 0.27 g of sodium dihydrogen phosphate dihydrate and 8.77 g of sodium chloride in water to make 1000 mL.

Flow rate: Adjust so that the retention time of epoetin alfa is about 16 minutes.

Time span of measurement: From the retention time corresponding to the exclusion volume of the size-exclusion column until the elution of epoetin alfa is finished.

System suitability—

Test for required detectability: To 1 volume of Epoetin Alfa (Genetical Recombination) add 49 volumes of the mobile phase, and use this solution as the solution for system suitability test. Confirm that the peak area of epoetin alfa obtained with a volume, equivalent to 1 μ g of protein, of the solution for system suitability test is equivalent to 1.5 to 2.5% of that with the same volume of Epoetin Alfa (Genetical Recombination).

System performance: Dissolve 40 mg of bovine serum albumin for gel filtration molecular mass marker and 20 mg of chymotrypsinogen for gel filtration molecular mass marker in 100 mL of the mobile phase. When the procedure is run with 50 μ L of this solution under the above operating conditions, bovine serum albumin and chymotrypsinogen are eluted in this order with the resolution between these peaks being not less than 4.

System repeatability: When the test is repeated 6 times with a volume of Epoetin Alfa (Genetical Recombination), equivalent to 50 μ g of protein, under the above operating conditions, the relative standard deviation of the area of the principal peak of epoetin alfa is not more than 2.0%.

(2) **Host cell proteins**—Being specified separately when the drug is granted approval based on the Law.

(3) **Host cell DNA**—Being specified separately when the

drug is granted approval based on the Law.

Assay (1) Protein content—Take a suitable amount of Epoetin Alfa (Genetical Recombination), dilute with phosphate buffer solution for epoetin alfa, if necessary, so that each mL contains 0.5 – 0.8 mg protein and use the solution as the sample solution. Determine the absorbance, A , at 280 nm of the sample solution as directed under Ultraviolet-visible Spectrophotometry <2.24>, using the phosphate buffer solution for epoetin alfa as the blank.

Amount (mg) of protein in 1 mL of Epoetin Alfa (Genetical Recombination)

$$= A \times d \times 0.909$$

d : Dilution factor for the sample solution

0.909: Reciprocal number of absorption coefficient ($E_{1\text{cm}}^{0.1\%}$) of epoetin alfa protein

(2) **Specific activity**

(i) **Animals:** Select healthy 6 to 8 weeks female mice (B6D2F1, etc.). Keep the mice for not less than a week before use, providing an appropriate uniform diet and water.

(ii) **Standard solutions:** To Epoetin Alfa RS add the bovine serum albumin-saline solution so that each mL contains exactly 10 – 40 units, and designate this solution as the high-dose standard solution, S_H . Dilute S_H exactly 4 times with the bovine serum albumin-saline solution, and designate this solution as the low-dose standard solution, S_L .

(iii) **Sample solutions:** To Epoetin Alfa (Genetical Recombination) add the bovine serum albumin-saline solution to make two sample solutions, the high-dose sample solution, T_H , which contains the Units per mL equivalent to S_H and the low-dose sample solution, T_L , which contains the Units per mL equivalent to S_L .

(iv) **Procedure:** Divide the animals into 4 equal groups of not less than 5 animals each. On the 1st, 2nd and 3rd days, inject exactly 0.2 mL each of the standard solutions and the sample solutions into each animal subcutaneously as indicated in the following design:

First group	S_H	Third group	T_H
Second group	S_L	Fourth group	T_L

On the 4th day, take a sufficient blood sample to perform the test from each animal. To 10 mL of the dilution fluid for particle counter add exactly 20 μ L of the blood sample, mix, add 100 μ L of the appropriate hemolysis agent, stir for 5 minutes, and determine the count of particles derived from hemolytic-resistant erythroid cells.

(v) **Calculation:** Logarithmic converted counts of the fine particles obtained with S_H , S_L , T_H and T_L in (iv) are symbolized as y_1 , y_2 , y_3 and y_4 , respectively. Sum up individual y_1 , y_2 , y_3 and y_4 to obtain Y_1 , Y_2 , Y_3 and Y_4 , respectively.

Specific activity (unit/mg protein) of Epoetin Alfa (Genetical Recombination)

$$= \text{activity (unit/mL) of Epoetin Alfa (Genetical Recombination)} / C$$

Activity (unit/mL) of Epoetin Alfa (Genetical Recombination)

$$= \text{antilog } M \times \text{unit in 1 mL of } S_H \times d$$

$$M = \log 4 \times Y_a / Y_b$$

$$Y_a = -Y_1 - Y_2 + Y_3 + Y_4$$

$$Y_b = Y_1 - Y_2 + Y_3 - Y_4$$

d : Dilution factor for T_H

C : Concentration (mg/mL) of protein obtained in Assay (1)

F' computed by the following equation should be smaller

than F shown in the table against n with which s^2 is calculated. Calculate L ($p = 0.95$) by use of the following equation: L should be not more than 0.3. If F' exceeds F , or if L exceeds 0.3, repeat the test, arranging the assay conditions.

$$F' = (Y_1 - Y_2 - Y_3 + Y_4)^2/4fs^2$$

f : Number of animals per group, which should be the same for each group and not less than 5.

$$s^2 = (\Sigma y^2 - Y/f)/n$$

Σy^2 : The sum of the squares of each y_1, y_2, y_3 and y_4 .

$$Y = Y_1^2 + Y_2^2 + Y_3^2 + Y_4^2$$

$$n = 4(f - 1)$$

$$L = 2\sqrt{(C - 1)\{CM^2 + (\log 4)^2\}}$$

$$C = Y_b^2/(Y_b^2 - 4fs^2t^2)$$

$F (= t^2)$ values against n

n	$t^2 = F$	n	$t^2 = F$	n	$t^2 = F$
1	161.45	13	4.667	25	4.242
2	18.51	14	4.600	26	4.225
3	10.129	15	4.543	27	4.210
4	7.709	16	4.494	28	4.196
5	6.608	17	4.451	29	4.183
6	5.987	18	4.414	30	4.171
7	5.591	19	4.381	40	4.085
8	5.318	20	4.351	60	4.001
9	5.117	21	4.325	120	3.920
10	4.965	22	4.301	∞	3.841
11	4.844	23	4.279		
12	4.747	24	4.260		

Containers and storage Containers—Tight containers.

Storage—Not exceeding -70°C .

Epoetin Beta (Genetical Recombination)

エポエチン ベータ (遺伝子組換え)

Protein moiety

```

APPRLLCDSR VLERYLLEAK EAENITTTGCA EHCSLINENIT VPDTKVNFYA
WKRMEVGQQA VEVWQGLALL SEAVLRGQAL LVNSSQPWEP LQLHVDKAVS
GLRSLTTLRL ALGAQKEALS PPDAASAAPL RTITADTERK LFRVYSNFLR
GKLLKLTGEA CRTGD

```

N24, N38, N83 and S126: glycosylation

Carbohydrate moiety (structure of major glycans)

N24, N38 and N83

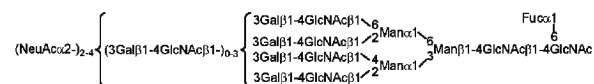

S126

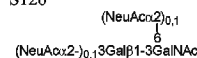

$\text{C}_{809}\text{H}_{1301}\text{N}_{229}\text{O}_{240}\text{S}_5$: 18235.70 (Protein moiety)
[122312-54-3]

Epoetin Beta (Genetical Recombination) is an aqueous solution in which a desired product is a recombinant human erythropoietin produced in Chinese hamster ovary cells. It is a glycoprotein (molecular mass: ca. 30,000) consisting of 165 amino acid residues.

It contains not less than 0.5 mg and not more than 1.5 mg of protein per mL, and not less than 1.5×10^5 units per mg of protein.

Description Epoetin Beta (Genetical Recombination) occurs as a clear and colorless liquid.

Identification (1) Use Epoetin Beta (Genetical Recombination) and Epoetin Beta RS as the sample solution and the standard solution, respectively. When perform a capillary electrophoresis with the sample solution and standard solution according to the following conditions, the mobility of each peak obtained from both solutions is the same and their migrating images are similar each other.

Operating conditions—

Detector: An ultraviolet absorption photometer (wavelength: 200 nm).

Column: A silica capillary tube 50 μm in inside diameter and about 50 cm in length, chemically coated inner surface with amino groups (about 40 cm in effective length).

Electrolyte solution: Dissolve 32.8 g of sodium dihydrogen phosphate dihydrate in water to make 1000 mL, and adjust to pH 4.5 with a solution, prepared by dissolving 75.2 g of disodium hydrogen phosphate dodecahydrate in water to make 1000 mL. To 19 volumes of this solution add 1 volume of ethanol (99.5).

Running temperature: A constant temperature of about 20°C .

Running conditions: Migration current (a constant current of about 45 μA), migration time (30 minutes).

Injection of sample and standard solutions: 5 seconds (pressurization: 0.5 psi).

Time span of measurement: From 10 minutes to 30 minutes after injection (excluding the peak of solvent ori-

gin).

System suitability—

System performance: When the procedure is run with the standard solution under the above operating conditions, more than 4 major peaks of epoetin beta are detected, and the resolution between the first and second eluted major peaks is not less than 0.8.

System repeatability: When the test is repeated 3 times with the standard solution under the above operating conditions, the relative standard deviation of the migration time of the first eluted major peak is not more than 2.0%.

(2) Desalt a volume each of Epoetin Beta (Genetical Recombination) and Epoetin Beta RS, equivalent to 600 μg of protein, by a suitable method, and term them as the desalted sample and the desalted reference standard, respectively. Dissolve the desalted sample and the desalted reference standard in 600 μL each of a solution, prepared by dissolving 2.3 g of *N*-ethylmorpholine in 100 mL of water and adjusting to pH 8.0 with acetic acid (100), and use these solutions as the desalted sample solution and the desalted reference standard solution, respectively. To 500 μL each of the desalted sample solution and the desalted reference standard solution add 3.3 μL of triethylamine for epoetin beta and 1.5 μL of 2-mercaptoethanol for epoetin beta, and react at 37°C for 1 hour. After cooling, add 5.5 μL of 4-vinylpyridine to them, and react at 25°C for 1 hour. To these solutions add 50 μL of diluted trifluoroacetic acid for epoetin beta (1 in 10) to stop the reaction, remove the reagents by a suitable method, and use the substances so obtained as the pyridylethylated sample and the pyridylethylated reference substance, respectively. Dissolve the pyridylethylated sample and the pyridylethylated reference substance separately in 500 μL of sodium hydrogen carbonate solution (21 in 2500). To 400 μL each of these solutions add 16 μL of a solution of lysyl endopeptidase in sodium hydrogen carbonate solution (21 in 2500) (1 in 50,000), and react at 37°C for 24 hours. While this reaction, additional two 16- μL portions of a solution of lysyl endopeptidase in sodium hydrogen carbonate (21 in 2500) (1 in 50,000) are added at 4 hours and 20 hours after starting the reaction. Then, stop the reaction by adding 100 μL of diluted trifluoroacetic acid for epoetin beta (1 in 10), and use these solutions as the sample solution and the standard solution, respectively. Perform the test with 100 μL each of the sample solution and standard solution as directed under Liquid Chromatography <2.01> according to the following conditions, and compare the chromatograms obtained from these solutions: both chromatograms show the similar peaks at the corresponding retention times.

Operating conditions—

Detector: An ultraviolet absorption photometer (wavelength: 214 nm).

Column: A stainless steel column 4.6 mm in inside diameter and 25 cm in length, packed with octadecylsilanized silica gel for liquid chromatography (5 μm in particle diameter).

Column temperature: A constant temperature of about 25°C.

Mobile phase A: A mixture of water and trifluoroacetic acid for epoetin beta (1000:1).

Mobile phase B: A mixture of acetonitrile for liquid chromatography, water, and trifluoroacetic acid for epoetin beta (900:100:1).

Flowing of mobile phase: Control the gradient by mixing the mobile phases A and B as directed in the following table.

Time after injection of sample (min)	Mobile phase A (vol%)	Mobile phase B (vol%)
0 - 10	90	10
10 - 30	90 → 80	10 → 20
30 - 50	80	20
50 - 130	80 → 40	20 → 60
130 - 140	40 → 10	60 → 90
140 - 150	10	90

Flow rate: Adjust so that the retention time of the first peak, which appears after the solvent peak, is about 17 minutes.

System suitability—

System performance: When the procedure is run with the standard solution under the above operating conditions, 9 major peptide peaks are appeared after the solvent peak, and the resolution between the peaks eluted at the fifth and the sixth is not less than 3.

Sialic acid content To exactly 100 μL of Epoetin Beta (Genetical Recombination) add 1 mL of resorcinol-copper (II) sulfate TS, and heat on a water bath for 30 minutes. After ice-cooling, add 2 mL of a mixture of *n*-butyl acetate and 1-butanol (4:1), shake vigorously, and use the upper layer as the sample solution. Separately, dissolve *N*-acetylneuraminic acid in water to make three solutions, containing 0.1 mg, 0.2 mg and 0.3 mg of *N*-acetylneuraminic acid in each mL, and use these solutions as the standard stock solution (1), the standard stock solution (2) and the standard stock solution (3), respectively. Pipet 100 μL each of these standard stock solutions, add 1 mL of resorcinol-copper (II) sulfate TS to them, then proceed in the same way as for the sample solution, and use these solutions so obtained as the standard solution (1), the standard solution (2) and the standard solution (3), respectively. Determine the absorbances of the sample solution and the standard solutions (1), (2) and (3) at 625 nm as directed under Ultraviolet-visible Spectrophotometry <2.24>. Calculate the amount of sialic acid (mg/mL) in the sample solution, by using the calibration curve obtained from the standard solutions, and calculate the amount of sialic acid in Epoetin Beta (Genetical Recombination) by the following equation: between 10 mol/mol and 13 mol/mol.

$$\text{Amount of sialic acid (mol/mol of epoetin beta protein)} = A/C \times 18,236/309.27$$

A: Amount (mg/mL) of sialic acid in the sample solution

C: Amount (mg/mL) of protein in Epoetin Beta (Genetical Recombination)

18,236: Molecular mass of protein moiety of epoetin beta

309.27: Molecular mass of *N*-acetylneuraminic acid

Oligosaccharide profile Being specified separately when the drug is granted approval based on the Law.

pH <2.54> 7.0 - 8.0

Purity (1) Related substances—Perform the test with 20 μL of Epoetin Beta (Genetical Recombination) as directed under Liquid Chromatography <2.01> according to the following conditions. Determine each peak area by the automatic integration method, and calculate the amount of these peaks other than the solvent peak by the area percentage method: the total area of the peaks other than epoetin beta is not more than 1.0%.

Operating conditions—

Detector: An ultraviolet absorption photometer (wave-

length: 214 nm).

Column: A stainless steel column 7.5 mm in inside diameter and 60 cm in length, packed with porous silica gel for liquid chromatography (10 μ m in particle diameter).

Column temperature: A constant temperature of about 25°C.

Mobile phase: Dissolve 1.6 g of sodium dihydrogen phosphate dihydrate and 16.1 g of sodium sulfate decahydrate in water to make 1000 mL, and adjust to pH 6.8 with a solution, prepared by dissolving 16.1 g of sodium sulfate decahydrate in 0.01 mol/L sodium hydroxide TS to make 1000 mL.

Flow rate: Adjust so that the retention time of epoetin beta is about 18 minutes.

Time span of measurement: About 2 times as long as the retention time of epoetin beta.

System suitability—

Test for required detectability: When the procedure is run with 20 μ L of diluted Epoetin Beta RS with water containing 0.05 vol% polysorbate 20 for epoetin beta (1 in 1000) under the above conditions, the peak of epoetin beta is detectable.

System performance: When the procedure is run with Epoetin Beta RS under the above conditions, the number of theoretical plates of the peak of epoetin beta is not less than 600.

System repeatability: When the test is repeated 6 times with 20 μ L of Epoetin Beta RS under the above operating conditions, the relative standard deviation of the peak area of epoetin beta is not more than 1.0%.

(2) Host cell proteins—Being specified separately when the drug is granted approval based on the Law.

(3) Host cell DNA—Being specified separately when the drug is granted approval based on the Law.

Assay (1) Protein content—Use Epoetin Beta (Genetical Recombination) and Epoetin Beta RS as the sample solution and the standard solution, respectively. Perform the test with exactly 15 μ L each of the sample solution and standard solution as directed under Liquid Chromatography <2.01> according to the following conditions, and determine the total area, A_T and A_S , of the main peak and the sub-peak of epoetin beta in each solution.

Amount (mg) of protein in 1 mL of Epoetin Beta (Genetical Recombination)

$$= C_S \times A_T/A_S$$

C_S : Protein concentration (mg/mL) of Epoetin Beta RS

Operating conditions—

Detector: An ultraviolet absorption photometer (wavelength: 214 nm).

Column: A stainless steel column 4.6 mm in inside diameter and 25 cm in length, packed with butylsilanized silica gel for liquid chromatography (5 μ m in particle diameter).

Column temperature: A constant temperature of about 25°C.

Mobile phase A: A mixture of water, acetonitrile for liquid chromatography and trifluoroacetic acid for epoetin beta (400:100:1).

Mobile phase B: A mixture of acetonitrile for liquid chromatography, water and trifluoroacetic acid for epoetin beta (400:100:1).

Flowing of mobile phase: Control the gradient by mixing the mobile phases A and B as directed in the following table.

Time after injection of sample (min)	Mobile phase A (vol%)	Mobile phase B (vol%)
0 – 18	65 → 50	35 → 50
18 – 33	50 → 0	50 → 100
33 – 43	0	100

Flow rate: Adjust so that the retention time of the main peak of epoetin beta is about 22 minutes.

System suitability—

System performance: When the procedure is run with 15 μ L of the standard solution under the above operating conditions, the main peak and the sub-peak of epoetin beta are eluted in this order, and the number of theoretical plates of the main peak is not less than 600.

System repeatability: When the test is repeated 6 times with 15 μ L of the standard solution under the above operating conditions, the relative standard deviation of the total area of the main peak and the sub-peak of epoetin beta is not more than 4.0%.

(2) Specific activity—To Epoetin Beta (Genetical Recombination) add 0.1 w/v% bovine serum albumin-sodium chloride-phosphate buffer solution to make three solutions so that each mL contains epoetin beta equivalent to 5, 10 and 20 units (estimate), and use these solutions as the sample solutions (1), (2) and (3), respectively. Separately, to Epoetin Beta RS add 0.1 w/v% bovine serum albumin-sodium chloride-phosphate buffer solution to make three solutions so that each mL contains epoetin beta equivalent to 5, 10 and 20 units, and use these solutions as the standard solutions (1), (2) and (3), respectively. Divide ICR strain mice into 6 equal groups of not less than 5 mice. Inject exactly 0.2 mL each of the sample solutions and the standard solutions to ICR strain mice of each group subcutaneously on the 1st, 2nd and 3rd days. On the 4th day, collect the blood from the mice, put 20 μ L each of the collected blood in 9.94 mL of blood dilution liquid, mix, and use these mixtures as the dilute blood solution. To each of the dilute blood solution add 100 μ L of a hemolytic agent, mix gently to hemolyze, and count the particles of hemolytic agent-resistant red cell by using a particle counter.

Determine the potency ratio (P_r) of the sample solution to the standard solution, and calculate the unit per mg protein of Epoetin Beta (Genetical Recombination) by the following equation.

$$P_r = 10^M$$

$$M = 4/3 \times i \times T_a/T_b$$

$$i = \log 2$$

$$T_a = -S_1 - S_2 - S_3 + U_1 + U_2 + U_3$$

$$T_b = -S_1 + S_3 - U_1 + U_3$$

U_1 : Sum of the responses obtained from the sample solution (1)

U_2 : Sum of the responses obtained from the sample solution (2)

U_3 : Sum of the responses obtained from the sample solution (3)

S_1 : Sum of the responses obtained from the standard solution (1)

S_2 : Sum of the responses obtained from the standard solution (2)

S_3 : Sum of the responses obtained from the standard solution (3)

Specific activity (unit/mg of protein) of Epoetin Beta (Genetical Recombination)
 $= S \times P_T \times D_T / D_S / C$

S: Potency (unit/mL) of Epoetin Beta RS
D_T: Dilution factor for the sample solution (3)
D_S: Dilution factor for the standard solution (3)
C: Protein amount (mg/mL) of Epoetin Beta (Genetical Recombination)

Containers and storage Containers—Tight containers.
 Storage—Not exceeding -20°C .

Ergocalciferol

Vitamin D₂

エルゴカルシフェロール

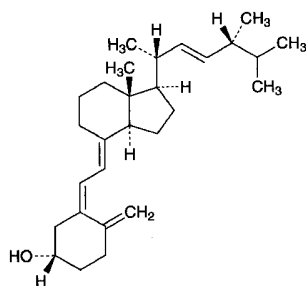

$\text{C}_{28}\text{H}_{44}\text{O}$: 396.65
 (3*S*,5*Z*,7*E*,22*E*)-9,10-Secoergosta-5,7,10(19),22-tetraen-3-ol
 [50-14-6]

Ergocalciferol contains not less than 97.0% and not more than 103.0% of ergocalciferol ($\text{C}_{28}\text{H}_{44}\text{O}$).

Description Ergocalciferol occurs as white crystals. It is odorless, or has a faint, characteristic odor.

It is freely soluble in ethanol (95), in diethyl ether and in chloroform, sparingly soluble in isooctane, and practically insoluble in water.

It is affected by air and by light.

Melting point: $115 - 118^{\circ}\text{C}$ Transfer Ergocalciferol to a capillary tube, and dry for 3 hours in a desiccator (in vacuum at a pressure not exceeding 2.67 kPa). Immediately fire-seal the capillary tube, put it in a bath fluid, previously heated to a temperature about 10°C below the expected melting point, and heat at a rate of rise of about 3°C per minute, and read the melting point.

Identification (1) Dissolve 0.5 mg of Ergocalciferol in 5 mL of chloroform, add 0.3 mL of acetic anhydride and 0.1 mL of sulfuric acid, and shake: a red color is produced, and rapidly changes through purple and blue to green.

(2) Determine the infrared absorption spectrum of Ergocalciferol as directed in the potassium bromide disk method under Infrared Spectrophotometry <2.25>, and compare the spectrum with the Reference Spectrum or the spectrum of Ergocalciferol RS: both spectra exhibit similar intensities of absorption at the same wave numbers.

Absorbance <2.24> $E_{1\text{cm}}^{1\%}$ (265 nm): 445 – 485 (10 mg, ethanol (95), 100 mL).

Optical rotation <2.49> $[\alpha]_{\text{D}}^{20}$: $+102 - +107^{\circ}$ (0.3 g, ethanol (95), 20 mL, 100 mm). Prepare the solution of Ergocalciferol within 30 minutes after the container has been opened, and determine the rotation within 30 minutes after the solution

has been prepared.

Purity Ergosterol—Dissolve 10 mg of Ergocalciferol in 2.0 mL of diluted ethanol (9 in 10), add a solution of 20 mg of digitonin in 2.0 mL of diluted ethanol (9 in 10), and allow the mixture to stand for 18 hours: no precipitate is formed.

Assay Weigh accurately about 30 mg each of Ergocalciferol and Ergocalciferol RS, and dissolve each in isooctane to make exactly 50 mL. Pipet 10 mL each of these solutions, add exactly 3 mL each of the internal standard solution, then add the mobile phase to make 50 mL, and use these solutions as the sample solution and the standard solution, respectively. Perform the test with 10 to 20 μL each of the sample solution and standard solution as directed under Liquid Chromatography <2.01> according to the following conditions, and calculate the ratios, Q_T and Q_S , of the peak area of ergocalciferol to that of the internal standard. Perform the procedure rapidly avoiding contact with air or other oxidizing agents and using light-resistant containers.

Amount (mg) of ergocalciferol ($\text{C}_{28}\text{H}_{44}\text{O}$) = $M_S \times Q_T / Q_S$

M_S : Amount (mg) of Ergocalciferol RS taken

Internal standard solution—A solution of dimethyl phthalate in isooctane (1 in 100).

Operating conditions—

Detector: An ultraviolet absorption photometer (wavelength: 254 nm).

Column: A stainless steel column 4.6 mm in inside diameter and 25 cm in length, packed with a silica gel for liquid chromatography (10 μm particle diameter).

Column temperature: A constant temperature of about 20°C .

Mobile phase: A mixture of hexane and *n*-amylalcohol (997:3).

Flow rate: Adjust so that the retention time of ergocalciferol is about 25 minutes.

System suitability—

System performance: Dissolve 15 mg of Ergocalciferol RS in 25 mL of isooctane. Transfer this solution to a flask, heat in an oil bath under a reflux condenser for 2 hours, and cool immediately to room temperature. Transfer the solution to a quartz test tube, and irradiate with a short-wave lamp (main wavelength: 254 nm) and a long-wave lamp (main wavelength: 365 nm) for 3 hours. To 10 mL of this solution add the mobile phase to make 50 mL. When the procedure is run with 10 μL of this solution under the above operating conditions, the ratios of the retention time of previtamin D₂, trans-vitamin D₂ and tachysterol₂ to that of ergocalciferol are about 0.5, about 0.6 and about 1.1, respectively, and the resolution between previtamin D₂ and trans-vitamin D₂ is not less than 0.7, and that between ergocalciferol and tachysterol₂ is not less than 1.0.

System repeatability: When the test is repeated 6 times with 10 μL of the standard solution under the above operating conditions, the relative standard deviation of the ratios of the peak area of ergocalciferol to that of the internal standard is not more than 1.0%.

Containers and storage Containers—Hermetic containers.

Storage—Light-resistant, under Nitrogen atmosphere, and in a cold place.

Ergometrine Maleate

エルゴメトリンマレイン酸塩

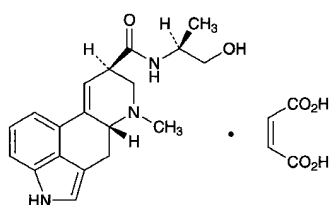

$C_{19}H_{23}N_3O_2 \cdot C_4H_4O_4$: 441.48

(8*R*)-*N*-[(2*S*)-1-Hydroxypropan-2-yl]-6-methyl-9,10-didehydroergoline-8-carboxamide monomaleate
[129-51-1]

Ergometrine Maleate, when dried, contains not less than 98.0% of ergometrine maleate ($C_{19}H_{23}N_3O_2 \cdot C_4H_4O_4$).

Description Ergometrine Maleate occurs as a white to pale yellow crystalline powder. It is odorless.

It is sparingly soluble in water, slightly soluble in methanol and in ethanol (95), and practically insoluble in diethyl ether.

It gradually changes to yellow in color on exposure to light.

Melting point: about 185°C (with decomposition).

Identification (1) Prepare a solution of Ergometrine Maleate (1 in 50): the solution shows a blue fluorescence.

(2) Dissolve 1 mg of Ergometrine Maleate in 5 mL of water. To 1 mL of this solution add 2 mL of 4-dimethylaminobenzaldehyde-ferric chloride TS, shake, and allow to stand for 5 to 10 minutes: a deep blue color develops.

(3) To 5 mL of a solution of Ergometrine Maleate (1 in 500) add 1 drop of potassium permanganate TS: the red color of the solution disappears immediately.

Optical rotation <2.49> $[\alpha]_D^{20} +48 - +57^\circ$ (after drying, 0.25 g, water, 25 mL, 100 mm).

pH <2.54> Dissolve 0.10 g of Ergometrine Maleate in 10 mL of water. The pH of the solution is between 3.0 and 5.0.

Purity (1) Clarity and color of solution—Dissolve 0.10 g of Ergometrine Maleate in 10 mL of water: the solution is clear and colorless to light yellow.

(2) Ergotamine and ergotamine—To 0.02 g of Ergometrine Maleate add 2 mL of a solution of sodium hydroxide (1 in 10), and heat to boiling: the gas evolved does not change moistened red litmus paper to blue.

(3) Related substances—Dissolve 5.0 mg each of Ergometrine Maleate and Ergometrine Maleate RS in 1.0 mL of methanol, and use these solutions as the sample solution and the standard solution, respectively. Perform the test with these solutions as directed under Thin-layer Chromatography <2.03>. Spot 10 μ L each of the sample solution and standard solution on a plate, prepared with silica gel for thin-layer chromatography and dilute sodium hydroxide TS. Develop the plate with a mixture of chloroform and methanol (4:1) to a distance of about 10 cm, and air-dry the plate. Spray evenly 4-dimethylaminobenzaldehyde TS on the plate: the spots obtained from the sample solution and the standard solution show a red-purple color and the same R_f value, and any spot from the sample solution other than that corresponding to the spot from the standard solution does not appear.

Loss on drying <2.41> Not more than 2.0% (0.2 g, silica gel, 4 hours).

Assay Weigh accurately about 10 mg each of Ergometrine Maleate and Ergometrine Maleate RS, previously dried in a desiccator (silica gel) for 4 hours, dissolve in water to make exactly 250 mL, and use these solutions as the sample solution and the standard solution, respectively. Pipet 2 mL of each solution into a separate brown glass-stoppered tube. To each tube add 4 mL of 4-dimethylaminobenzaldehyde-iron (III) chloride TS, exactly measured, while cooling in an ice bath, then warm at 45°C for 10 minutes. Allow to stand at room temperature for 20 minutes, and perform the test with these solutions as directed under Ultraviolet-visible Spectrophotometry <2.24>, using a solution, prepared with 2 mL of water in the same manner, as the blank. Determine the absorbances, A_T and A_S , of the subsequent solutions of the sample solution and the standard solution at 550 nm, respectively.

Amount (mg) of ergometrine maleate ($C_{19}H_{23}N_3O_2 \cdot C_4H_4O_4$)
= $M_S \times A_T / A_S$

M_S : Amount (mg) of Ergometrine Maleate RS taken

Containers and storage Containers—Tight containers.

Storage—Light-resistant.

Ergometrine Maleate Injection

エルゴメトリンマレイン酸塩注射液

Ergometrine Maleate Injection is an aqueous injection.

It contains not less than 90.0% and not more than 110.0% of the labeled amount of ergometrine maleate ($C_{19}H_{23}N_3O_2 \cdot C_4H_4O_4$: 441.48).

Method of preparation Prepare as directed under Injections, with Ergometrine Maleate.

Description Ergometrine Maleate Injection is a clear, colorless to pale yellow liquid.

pH: 2.7 – 3.5

Identification (1) Measure a volume of Ergometrine Maleate Injection, equivalent to 3 mg of Ergometrine Maleate, if necessary, dilute with water or evaporate on a water bath to make 15 mL, and use this solution as the sample solution. The sample solution shows a blue fluorescence.

(2) To 1 mL of the sample solution obtained in (1) add 1 mL of ammonia TS, and extract with 20 mL of diethyl ether. To the diethyl ether extract add 1 mL of dilute sulfuric acid, shake, and warm to remove diethyl ether in a water bath. Cool, to the residue obtained add 2 mL of 4-dimethylaminobenzaldehyde-iron (III) chloride TS, and allow to stand for 5 to 10 minutes: a deep blue color develops.

(3) To 5 mL of the sample solution obtained in (1) add 1 drop of potassium permanganate TS: a red color disappears immediately.

Bacterial endotoxins <4.01> Less than 1500 EU/mg.

Extractable volume <6.05> It meets the requirement.

Foreign insoluble matter <6.06> Perform the test according to Method 1: it meets the requirement.

Insoluble particulate matter <6.07> It meets the requirement.

Sterility <4.06> Perform the test according to the Membrane filtration method: it meets the requirement.

Assay Transfer an exactly measured volume of Ergometrine Maleate Injection, equivalent to about 2 mg of ergometrine maleate ($C_{19}H_{23}N_3O_2 \cdot C_4H_4O_4$), and add sodium chloride in a ratio of 0.3 g to 1 mL of the solution. To this mixture add 20 mL of diethyl ether and 2 mL of ammonia TS, shake, and extract. Further, extract with three 15-mL portions of diethyl ether, combine all the extracts, add 5 g of anhydrous sodium sulfate, filter through a pledget of absorbent cotton, and wash with three 5-mL portions of diethyl ether. Add the washings to the filtrate, shake with 5 mL of dilute sulfuric acid, evaporate the diethyl ether by warming in a current of nitrogen, to the remaining solution add water to make exactly 50 mL, and use this solution as the sample solution. Separately, weigh accurately about 2 mg of Ergometrine Maleate RS, previously dried in a desiccator (silica gel) for 4 hours, add water to make exactly 50 mL, and use this solution as the standard solution. Transfer 2 mL each of the sample solution and standard solution, accurately measured, to separate glass-stoppered test tubes, and proceed as directed in the Assay under Ergometrine Maleate.

Amount (mg) of ergometrine maleate ($C_{19}H_{23}N_3O_2 \cdot C_4H_4O_4$)
 $= M_S \times A_T / A_S$

M_S : Amount (mg) of Ergometrine Maleate RS taken

Containers and storage Containers—Hermetic containers, and colored containers may be used.

Storage—Light-resistant, and in a cold place.

Ergometrine Maleate Tablets

エルゴメトリンマレイン酸塩錠

Ergometrine Maleate Tablets contain not less than 90.0% and not more than 110.0% of the labeled amount of ergometrine maleate ($C_{19}H_{23}N_3O_2 \cdot C_4H_4O_4$; 441.48).

Method of preparation Prepare as directed under Tablets, with Ergometrine Maleate.

Identification To a quantity of powdered Ergometrine Maleate Tablets, equivalent to 3 mg of Ergometrine Maleate, add 15 mL of warm water, shake, and filter: the filtrate shows a blue fluorescence. Proceed with this solution as directed in the Identification (2) and (3) under Ergometrine Maleate.

Uniformity of dosage units <6.02> Perform the test according to the following method: it meets the requirement of the Content uniformity test.

Transfer 1 tablet of Ergometrine Maleate Tablets to a brown glass-stoppered centrifuge tube, and add exactly V mL of a solution of L-tartaric acid (1 in 100) so that each mL contains about 40 μ g of ergometrine maleate ($C_{19}H_{23}N_3O_2 \cdot C_4H_4O_4$). Stopper the tube, shake for 30 minutes vigorously, centrifuge, and use the supernatant liquid as the sample solution. Separately, weigh accurately about 4 mg of Ergometrine Maleate RS, previously dried in a desiccator (silica gel) for 4 hours, dissolve in water to make exactly 100 mL, and use this solution as the standard solution. Pipet 4 mL each of the sample solution and standard solution into separate brown glass-stoppered test tubes, add exactly 8 mL each of 4-dimethylaminobenzaldehyde-iron (III) chloride TS while cooling in an ice bath, after shaking,

and allow to stand for 1 hour at ordinary temperature. Perform the test with these solutions as directed under Ultraviolet-visible Spectrophotometry <2.24>, using a solution, prepared with 4 mL of water in the same manner, as the blank. Determine the absorbances, A_T and A_S , of the subsequent solutions of the sample solution and the standard solution at 550 nm, respectively.

Amount (mg) of ergometrine maleate ($C_{19}H_{23}N_3O_2 \cdot C_4H_4O_4$)
 $= M_S \times A_T / A_S \times V / 100$

M_S : Amount (mg) of Ergometrine Maleate RS taken

Assay Weigh accurately, and powder not less than 20 Ergometrine Maleate Tablets. Weigh accurately a portion of the powder, equivalent to about 2 mg of ergometrine maleate ($C_{19}H_{23}N_3O_2 \cdot C_4H_4O_4$), transfer to a glass filter (G4), add 10 mL of a solution of L-tartaric acid (1 in 100), and filter with thorough shaking. Repeat the procedures 3 times, combine the filtrates, add a solution of L-tartaric acid (1 in 100) to make exactly 50 mL, and use this solution as the sample solution. Separately, weigh accurately about 2 mg of Ergometrine Maleate RS, previously dried in a desiccator (silica gel) for 4 hours, dissolve in a solution of L-tartaric acid (1 in 100) to make exactly 50 mL, and use this solution as the standard solution. Pipet 2 mL each of the sample solution and standard solution, and proceed as directed in the Assay under Ergometrine Maleate.

Amount (mg) of ergometrine maleate ($C_{19}H_{23}N_3O_2 \cdot C_4H_4O_4$)
 $= M_S \times A_T / A_S$

M_S : Amount (mg) of Ergometrine Maleate RS taken

Containers and storage Containers—Well-closed containers.

Storage—Light-resistant.

Ergotamine Tartrate

エルゴタミン酒石酸塩

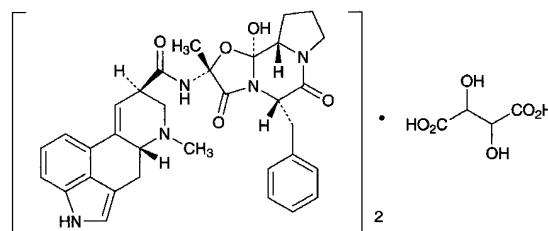

$(C_{33}H_{35}N_5O_5)_2 \cdot C_4H_6O_6$; 1313.41

(5'S)-5'-Benzyl-12'-hydroxy-2'-methyletergotaman-3',6',18-trione hemitartrate
 [379-79-3]

Ergotamine Tartrate contains not less than 98.0% of ergotamine tartrate [$(C_{33}H_{35}N_5O_5)_2 \cdot C_4H_6O_6$], calculated on the dried basis.

Description Ergotamine Tartrate occurs as colorless crystals, or a white to pale yellow-white or grayish white crystalline powder.

It is slightly soluble in water and in ethanol (95).

Melting point: about 180°C (with decomposition).

Identification (1) Dissolve 1 mg of Ergotamine Tartrate in 10 mL of a mixture of acetic acid (100) and ethyl acetate (1:1). To 0.5 mL of this solution add slowly 0.5 mL of sulfuric acid, with shaking in cold water, and allow to stand: a

purple color develops. To this solution add 0.1 mL of diluted iron (III) chloride TS (1 in 12): the color of the solution changes to blue to blue-purple.

(2) Dissolve 1 mg of Ergotamine Tartrate in 5 mL of a solution of L-tartaric acid (1 in 100). To 1 mL of this solution add 2 mL of 4-dimethylaminobenzaldehyde-iron (III) chloride TS, and shake: a blue color develops.

Optical rotation <2.49> Ergotamine base $[\alpha]_D^{20}$: -155 – -165° . Dissolve 0.35 g of Ergotamine Tartrate in 25 mL of a solution of L-tartaric acid (1 in 100), add 0.5 g of sodium hydrogen carbonate, shake gently and sufficiently, and extract with four 10-mL portions of ethanol-free chloroform. Filter the extracts successively through a small filter paper, moistened with ethanol-free chloroform, into a 50-mL volumetric flask. Allow the flask to stand in a water bath at 20°C for 10 minutes, and determine the optical rotation in a 100-mm cell. Separately, pipet 25 mL of this solution, evaporate to dryness under reduced pressure at a temperature not higher than 45°C , dissolve the residue in 25 mL of acetic acid (100), and titrate <2.50> with 0.05 mol/L perchloric acid VS (indicator: 1 drop of crystal violet TS). Perform a blank determination in the same manner, and make any necessary correction. Calculate the specific rotation of the ergotamine base from the consumed volume of 0.05 mol/L perchloric acid VS and the optical rotation.

Each mL of 0.05 mol/L perchloric acid VS
= 29.08 mg of $\text{C}_{33}\text{H}_{35}\text{N}_5\text{O}_5$

Purity Related substances—Conduct this procedure without exposure to light, using light-resistant vessels. To 40 mg of Ergotamine Tartrate add 10 mL of a solution of L-tartaric acid in diluted methanol (1 in 2) (1 in 1000), dissolve with thorough shaking, and use this solution as the sample solution. Pipet 1 mL of the sample solution, add a solution of L-tartaric acid in diluted methanol (1 in 2) (1 in 1000) to make exactly 50 mL, and use this solution as the standard solution. Perform the test with these solutions as directed under Thin-layer Chromatography <2.03>. Spot 10 μL each of the sample solution and standard solution on a plate of silica gel for thin-layer chromatography. Develop the plate with a mixture of chloroform and methanol (9:1) to a distance of about 10 cm, and air-dry the plate. Spray evenly 4-dimethylaminobenzaldehyde TS on the plate: the spots other than the principal spot obtained from the sample solution are not more intense than the spot from the standard solution.

Loss on drying <2.41> Not more than 5.0% (0.1 g, in vacuum, 60°C , 4 hours).

Assay Weigh accurately about 0.2 g of Ergotamine Tartrate, dissolve in 15 mL of a mixture of acetic acid (100) and acetic anhydride (50:3), and titrate <2.50> with 0.05 mol/L perchloric acid VS (indicator: 1 drop of crystal violet TS). Perform a blank determination in the same manner, and make any necessary correction.

Each mL of 0.05 mol/L perchloric acid VS
= 32.84 mg of $(\text{C}_{33}\text{H}_{35}\text{N}_5\text{O}_5)_2 \cdot \text{C}_4\text{H}_6\text{O}_6$

Containers and storage Containers—Tight containers.

Storage—Light-resistant, and almost well-filled, or under nitrogen atmosphere, and not exceeding 5°C .

Eribulin Mesilate

エリブリンメシル酸塩

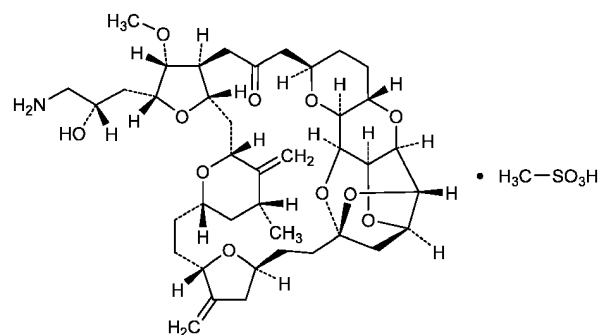

$\text{C}_{40}\text{H}_{59}\text{NO}_{11} \cdot \text{CH}_4\text{O}_3\text{S}$: 826.00
(2*R*,3*R*,3*aS*,7*R*,8*aS*,9*S*,10*aR*,11*S*,12*R*,13*aR*,13*bS*,15*S*,18*S*,21*S*,24*S*,26*R*,28*R*,29*aS*)-2-[(2*S*)-3-Amino-2-hydroxypropyl]-3-methoxy-26-methyl-20,27-dimethylidenehexacosahydro-11,15:18,21:24,28-triepoxy-7,9-ethano-12,15-methano-9*H*,15*H*-furo[3,2-*i*]furo[2',3':5,6]pyrano[4,3-*b*][1,4]dioxacyclopentacosin-5(4*H*)-one monomethanesulfonate
[441045-17-6]

Eribulin Mesilate contains not less than 95.0% and not more than 102.0% of eribulin mesilate ($\text{C}_{40}\text{H}_{59}\text{NO}_{11} \cdot \text{CH}_4\text{O}_3\text{S}$), and not less than 9.8% and not more than 12.2% of methanesulfonic acid ($\text{CH}_4\text{O}_3\text{S}$), calculated on the anhydrous basis.

Manufacture Eribulin Mesilate has 19 chiral carbons, and its purity tests can not estimate all isomers derived from them. Therefore, based on sound science and the understanding of the product and the manufacturing process, control and manage the isomers and related substances during manufacturing process, and ensure the three-dimensional structure of eribulin mesilate. In the quality control strategy of Eribulin Mesilate, control the related substances including the principal isomers in the drug substance or starting materials and intermediates in upstream process. The acceptance values are not more than 0.22% and not more than 0.68% for the related substances B and C, which are the isomers at position C34 and controlled in the drug substance, and are not more than the identification threshold (0.10%) for the related substances including other isomers. When Eribulin Mesilate is manufactured through the compounds 1 and 2, control as follows.

In the compound 1, control so that the isomers at positions C3 and C11, C12 *cis*-olefin, and other related substances are not more than the identification threshold (0.10%). In the compound 2, control so that the isomers at positions C17 and C29 are not more than 0.30%, and the isomer at position C20 is not more than 0.50%, the isomer at position C25 is not more than 0.40%, and the isomers at positions C23, C27, C34 and C18/C19 *endo*-olefin and the other related substances are not more than the identification threshold (0.10%).

Furthermore, ensure that the isomers at positions C17, C20, C25 and C29 are not more than the identification threshold (0.10%) in the processes after the compounds 1 and 2, and the other related substances are not more than the qualification threshold (0.15%).

When manufactured without reaction using the compounds 1 and 2, perform the control based on the control mentioned above.

The position numbers of eribulin mesilate used in this Manufacture are as follows. The numbers are used commonly for the related substances, but are not related to the position numbers prescribed by the chemical names.

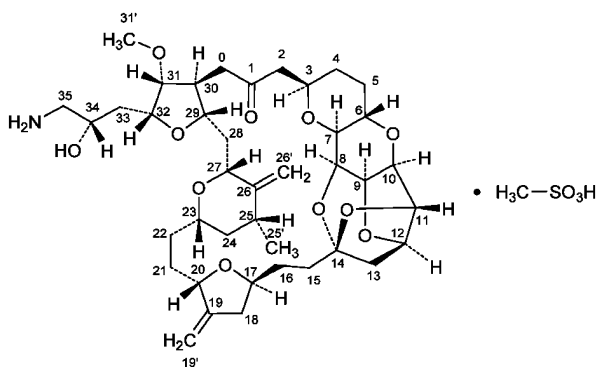

Position numbers of Eribulin Mesilate in Manufacture

Description Eribulin Mesilate occurs as a white powder.

It is freely soluble in water, in methanol, in ethanol (99.5) and in dimethylsulfoxide.

It is hygroscopic.

Identification (1) Determine the ^1H spectrum of a solution of Eribulin Mesilate in deuterated methanol for nuclear magnetic resonance spectroscopy (1 in 200), as directed under Nuclear Magnetic Resonance Spectroscopy <2.21>, using light hydrogen contaminated in deuterated methanol for nuclear magnetic resonance spectroscopy as an internal reference compound and the chemical shift of methyl group of deuterated methanol as δ 3.3 ppm: it exhibits a doublet signal A at around δ 1.1 ppm, a multiplet signal B at around δ 2.7 ppm and a singlet signal C at around δ 2.7 ppm, a singlet signal D at around δ 3.4 ppm, a doublet signal E at around δ 3.7 ppm, a doublet signal F at around δ 4.5 ppm, a triplet signal G at around δ 4.6 ppm, and a triplet signal H at around δ 4.7 ppm. The ratio of integrated intensity of these signals, A:B + C:D:E:F:G:H, is about 3:5:3:1:1:1:1. (When measured with a nuclear magnetic resonance spectrometer having ^1H resonance frequency of not less than or equal to 400 MHz.)

(2) Perform the test with 15 μL each of the sample solution and standard solution obtained in the Assay (2) as directed under Liquid Chromatography <2.01> according to the following conditions: the retention times of the peaks of methanesulfonic acid in the chromatograms obtained from the sample solution and standard solution are the same.

Operating conditions—

Proceed as directed in the operating conditions in the Assay (2).

System suitability—

Proceed as directed in the system suitability in the Assay (2).

Optical rotation <2.49> $[\alpha]_{365}^{20}$: -160 – -210° (50 mg calculated on the anhydrous and solvent-free basis, dimethylsulfoxide, 10 mL, 100 mm).

Purity (1) Heavy metals—Being specified separately when the drug is granted approval based on the Law.

(2) Related substances—Weigh accurately about 20 mg of Eribulin Mesilate, dissolve in the dissolving solution to make exactly 5 mL, and use this solution as the sample solution. Separately, weigh accurately about 20 mg of Eribulin Mesilate RS (separately determine the water <2.48> in the same manner as Eribulin Mesilate), dissolve in the dissolving solution to make exactly 5 mL. Pipet 1 mL of this solution,

add the dissolving solution to make exactly 100 mL, and use this solution as the standard solution. Perform the test with exactly 5 μL each of the sample solution and standard solution as directed under Liquid Chromatography <2.01> according to the following conditions. Determine each peak area, A_T , of the related substances in the sample solution and the peak area, A_S , of eribulin in the standard solution by the automatic integration method, and calculate the amounts of the related substances by the following formula: the amounts of related substance A having the relative retention time of about 0.29 to eribulin, related substance B having the relative retention time of about 0.87, related substance C having the relative retention time of about 1.07, related substance D having the relative retention time of about 1.29, related substance E having the relative retention time of about 1.37, and related substance F having the relative retention time of about 1.67, are not more than 0.15%, 0.22%, 0.68%, 0.50%, 0.15%, and 0.19%, respectively, and other related substances are not more than 0.10%. Furthermore, the total amount of these related substances is not more than 3.0%.

$$\text{Amount (\%)} \text{ of related substance} = M_S/M_T \times A_T/A_S$$

M_S : Amount (mg) of Eribulin Mesilate RS taken, calculated on the anhydrous basis

M_T : Amount (mg) of Eribulin Mesilate taken, calculated on the anhydrous basis

Dissolving solution—A mixture of water, acetonitrile for liquid chromatography and phosphoric acid (6500:3500:7) adjusted to pH 6.9 – 7.1 with diluted ammonium water (28) (1 in 5) or 1 mol/L hydrochloric acid TS.

Operating conditions—

Detector, column, column temperature, mobile phase, and flow rate: Proceed as directed in the operating conditions in the Assay (1).

Time span of measurement: For 85 minutes after injection, beginning after the solvent peak.

System suitability—

System performance: Proceed as directed in the system suitability in the Assay (1).

Test for required detectability: Pipet 1 mL of the standard solution, and add the dissolving solution to make exactly 20 mL. Confirm that the peak area of eribulin obtained with 5 μL of this solution is equivalent to 3.5 to 6.5% of that with 5 μL of the standard solution.

System repeatability: When the test is repeated 5 times with 5 μL of the solution for system suitability test obtained in the Assay (1) under the above operating conditions, the relative standard deviation of the peak area of eribulin is not more than 1.0%.

(3) Residual solvent—Being specified separately when the drug is granted approval based on the Law.

Water <2.48> Not more than 3.0% (Weigh accurately 15–25 mg of Eribulin Mesilate, dissolve in 2.5 mL of methanol for water determination, and perform the test with exactly 1 mL of this solution; coulometric titration).

Assay (1) Eribulin Mesilate—Weigh accurately about 20 mg each of Eribulin Mesilate and Eribulin Mesilate RS (separately determine the water <2.48> in the same manner as Eribulin Mesilate), dissolve each in the dissolving solution to make exactly 5 mL, and use these solutions as the sample solution and the standard solution. Perform the test with exactly 5 μL each of the sample solution and standard solution as directed under Liquid Chromatography <2.01> according to the following conditions, and determine the peak areas,

A_T and A_S , of eribulin in each solution.

$$\text{Amount (mg) of eribulin mesilate (C}_{40}\text{H}_{59}\text{NO}_{11}\cdot\text{CH}_4\text{O}_3\text{S)} \\ = M_S \times A_T/A_S$$

M_S : Amount (mg) of Eribulin Mesilate RS taken, calculated on the anhydrous basis

Dissolving solution—A mixture of water, acetonitrile for liquid chromatography and phosphoric acid (6500:3500:7) adjusted to pH 6.9–7.1 with diluted ammonia water (28) (1 in 5) or 1 mol/L hydrochloric acid TS.

Operating conditions—

Detector: An ultraviolet absorption photometer (wavelength: 200 nm).

Column: A stainless steel column 3 mm in inside diameter and 15 cm in length, packed with octadecylsilanized silica gel for liquid chromatography (3 μm in particle diameter).

Column temperature: A constant temperature of about 40°C.

Mobile phase A: Dissolve 7.0 g of ammonium trifluoromethanesulfonate in 760 mL of water, add 3.0 mL of a solution of tetrabutylammonium dihydrogen phosphate (17 in 50) and 240 mL of acetonitrile for liquid chromatography, and adjust to pH 6.9–7.1 with diluted ammonium water (28) (1 in 5) or 1 mol/L hydrochloric acid TS.

Mobile phase B: Dissolve 7.0 g of ammonium trifluoromethanesulfonate in 300 mL of water, add 3.0 mL of a solution of tetrabutylammonium dihydrogen phosphate (17 in 50), 700 mL of acetonitrile for liquid chromatography and 20 mL of 2-propanol for liquid chromatography, and adjust to pH 6.9–7.1 with diluted ammonium water (28) (1 in 5) or 1 mol/L hydrochloric acid TS.

Flowing of mobile phase: Control the gradient by mixing the mobile phases A and B as directed in the following table.

Time after injection of sample (min)	Mobile phase A (vol%)	Mobile phase B (vol%)
0–55	100	0
55–75	100 → 0	0 → 100
75–85	0	100
85–86	0 → 100	100 → 0
86–105	100	0

Flow rate: Control the flow rate as directed in the following table.

Time after injection of sample (min)	Flow rate (mL/minute)
0–55	0.50
55–75	0.50 → 0.63
75–105	0.63

System suitability—

System performance: Dissolve 2 mg of Eribulin Mesilate Related Substance C for System Suitability RS in the dissolving solution to make exactly 50 mL. To 0.2 mL of this solution add 4 mg of Eribulin Mesilate RS, dissolve in the dissolving solution to make exactly 1 mL, and use this solution as the solution for system suitability test. When the procedure is run with 5 μL of the solution for system suitability test under the above operating conditions, eribulin and the related substance C are eluted in this order with the resolution between these peaks being not less than 1.5. The number of theoretical plates and the symmetry factor of the peak of

eribulin are not less than 13,500 and not more than 1.5, respectively.

System repeatability: When the test is repeated 5 times with 5 μL of the solution for system suitability test under the above operating conditions, the relative standard deviation of the peak area of eribulin is not more than 1.0%.

(2) Methanesulfonic acid—Weigh accurately about 50 mg of Eribulin Mesilate, dissolve in a mixture of the mobile phase and acetonitrile for liquid chromatography (13:7) to make exactly 10 mL, and use this solution as the sample solution. Separately, weigh accurately about 50 mg of methanesulfonic acid, dissolve in a mixture of the mobile phase and acetonitrile for liquid chromatography (13:7) to make exactly 100 mL, and use this solution as the standard solution. Perform the test with 15 μL each of the sample solution and standard solution as directed under Liquid Chromatography <2.01> according to the following conditions, and determine the peak areas, A_T and A_S , of methanesulfonic acid in each solution. Calculate the content of methanesulfonic acid by the following formula.

$$\text{Content (\%)} \text{ of methanesulfonic acid (CH}_4\text{O}_3\text{S)} \\ = M_S \times A_T/A_S \times 1/10$$

M_S : Amount (mg) of methanesulfonic acid taken

Operating conditions—

Detector: An electric conductivity detector.

Column: A stainless steel column 4.6 mm in inside diameter and 25 cm in length, packed with aminopropylsilanized silica gel for liquid chromatography (5 μm in particle diameter).

Column temperature: A constant temperature of about 40°C.

Mobile phase: Dissolve 2.8 g of sodium dihydrogen phosphate monohydrate in 950 mL of water, add 11 μL of phosphoric acid, adjust to pH 4.2–4.3 with phosphoric acid if necessary, and add 50 mL of acetonitrile for liquid chromatography.

Flow rate: Adjust so that the retention time of methanesulfonic acid is about 6.5 minutes.

System suitability—

System performance: When the procedure is run with 15 μL of the standard solution under the above operating conditions, the number of theoretical plates and the symmetry factor of the peak of methanesulfonic acid are not less than 12,000 and not more than 0.7–1.5, respectively.

System repeatability: When the test is repeated 6 times with 15 μL of the standard solution under the above operating conditions, the relative standard deviation of the peak area of methanesulfonic acid is not more than 3.0%.

Containers and storage Containers—Tight containers.

Storage—Light-resistant, at a temperature not exceeding –65°C.

Others

Compound 1:

Methyl{(2*R*,4*aS*,6*S*,7*R*,8*S*,8*aS*)-7,8-bis{[(1,1-dimethylethyl)dimethylsilyl]oxy}-6-[(1*S*,2*E*)-1-[(1,1-dimethylethyl)dimethylsilyl]oxy]-3-iodoprop-2-en-1-yl]octahydropyrano[3,2-*b*]pyran-2-yl}acetate

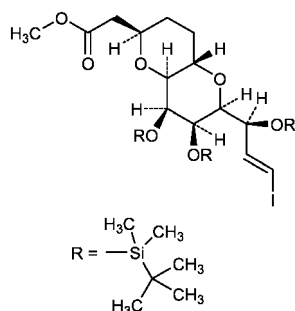

Compound 2:

3-[(2*S*,5*S*)-5-{2-[(2*S*,4*R*,6*R*)-6-[(2*S*,3*S*,4*R*,5*R*)-5-[(2*S*)-2,3-Bis{[(1,1-dimethylethyl)dimethylsilyl]oxy}propyl]-4-methoxy-3-[(phenylsulfonyl)methyl]tetrahydrofuran-2-yl]methyl}-4-methyl-5-methylidenetetrahydro-2*H*-pyran-2-yl]ethyl]-4-methylidene-tetrahydrofuran-2-yl]propan-1-ol

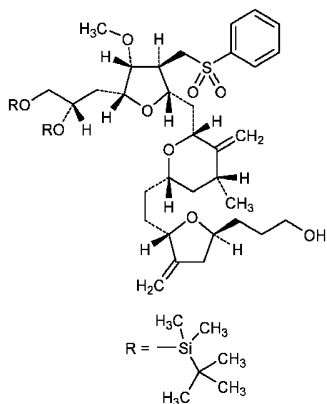

Related substance A:

(1*R*,3*S*,8*S*,11*S*,14*S*,16*R*,18*R*,20*S*,22*R*,23*R*,24*S*,28*R*,31*S*,33*S*,34*R*,35*S*,37*S*)-22-[(2*S*)-3-Amino-2-hydroxypropyl]-34,37-dihydroxy-23-methoxy-16-methyl-10,17-dimethylidene-2,21,32,36,38,39-hexaoxaheptacyclo [26.6.2.1^{3,33}.1^{8,11}.1^{14,18}.0^{20,24}.0^{31,35}]nonatriacontane-5,26-dione

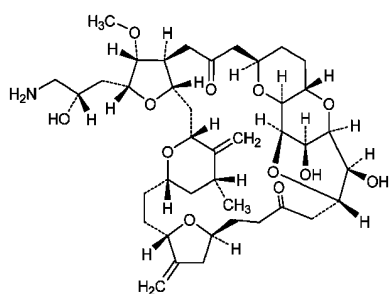

Related substance B:

(2*R*,3*R*,3*aS*,7*R*,8*aS*,9*S*,10*aR*,11*S*,12*R*,13*aR*,13*bS*,15*S*,18*S*,21*S*,24*S*,26*R*,28*R*,29*aS*)-2-[(2*S*)-3-Amino-2-hydroxypropyl]-3-methoxy-26-methyl-20,27-dimethylidenehexacosahydro-11,15:18,21:24,28-triepoxy-7,9-ethano-12,15-methano-9*H*,15*H*-furo[3,2-*i*]furo[2',3':5,6]pyrano[4,3-*b*][1,4]dioxacyclopentacosin-5(4*H*)-one

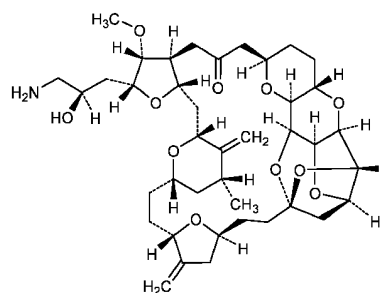

Related substance C:

(2*R*,3*R*,3*aS*,7*R*,8*aS*,9*S*,10*aR*,11*S*,12*R*,13*aR*,13*bS*,15*S*,18*S*,21*S*,24*S*,26*R*,28*R*,29*aS*)-2-[(2*R*)-2-Amino-3-hydroxypropyl]-3-methoxy-26-methyl-20,27-dimethylidenehexacosahydro-11,15:18,21:24,28-triepoxy-7,9-ethano-12,15-methano-9*H*,15*H*-furo[3,2-*i*]furo[2',3':5,6]pyrano[4,3-*b*][1,4]dioxacyclopentacosin-5(4*H*)-one

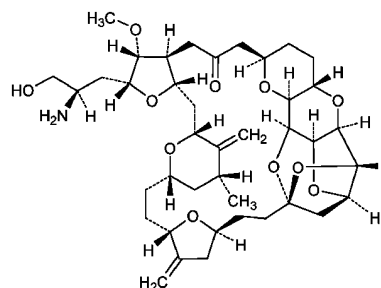

Related substance D:

(1*R*,2*S*,3*S*,4*S*,5*S*,6*R*,11*S*,14*S*,17*S*,19*R*,21*R*,23*S*,25*R*,26*R*,27*S*,31*R*,34*S*)-25-[(2*S*)-3-Amino-2-hydroxypropyl]-2,5-dihydroxy-26-methoxy-19-methyl-13,20-dimethylidene-24,35,36,37,38,39-hexaoxaheptacyclo [29.3.1.1^{3,6}.1^{4,34}.1^{11,14}.1^{17,21}.0^{23,27}]nonatriacontane-8,29-dione

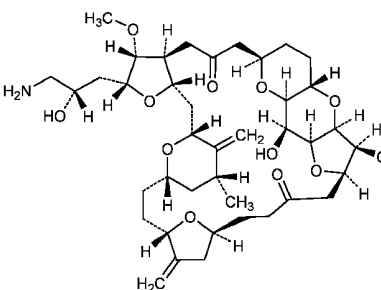

Related substance E:

(1*R*,2*S*,3*S*,4*S*,5*S*,6*S*,11*S*,14*S*,17*S*,19*R*,21*R*,23*S*,25*R*,26*R*,27*S*,31*R*,34*S*)-25-[(2*S*)-3-Amino-2-hydroxypropyl]-2,5-dihydroxy-26-methoxy-19-methyl-13,20-dimethylidene-24,35,36,37,38,39-hexaoxaheptacyclo [29.3.1.1^{3,6}.1^{4,34}.1^{11,14}.1^{17,21}.0^{23,27}]nonatriacontane-8,29-dione

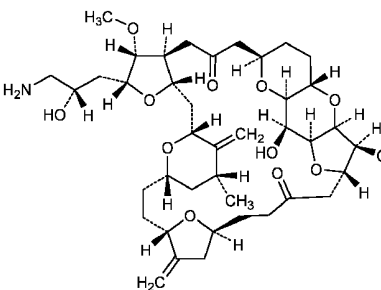

Related substance F:

(2*R*,3*R*,3*aS*,7*R*,8*aS*,9*S*,10*aR*,11*S*,12*R*,13*aR*,13*bS*,15*S*,18*S*,21*S*,24*S*,26*R*,28*R*,29*aS*)-2-[(2*S*)-2,3-Dihydroxypropyl]-3-methoxy-26-methyl-20,27-dimethylidenehexacosahydro-

11,15:18,21:24,28-triepoxy-7,9-ethano-12,15-methano-9*H*,15*H*-furo[3,2-*i*]furo[2',3':5,6]pyrano[4,3-*b*][1,4]dioxacyclopentacosin-5(4*H*)-one

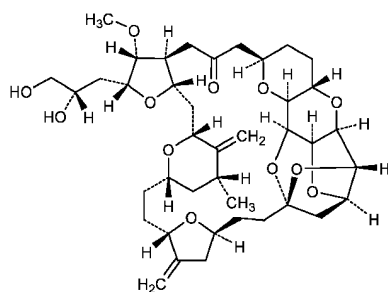

Erythromycin

エリスロマイシン

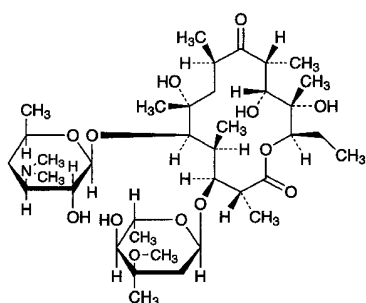

$C_{37}H_{67}NO_{13}$: 733.93
(2*R*,3*S*,4*S*,5*R*,6*R*,8*R*,10*R*,11*R*,12*S*,13*R*)-5-(3,4,6-Trideoxy-3-dimethylamino- β -D-xylohexopyranosyloxy)-3-(2,6-dideoxy-3-C-methyl-3-O-methyl- α -L-ribo-hexopyranosyloxy)-6,11,12-trihydroxy-2,4,6,8,10,12-hexamethyl-9-oxopentadecan-13-olide
[114-07-8]

Erythromycin is a macrolide substance having antibacterial activity produced by the growth of *Saccharopolyspora erythraea*.

It contains not less than 930 μ g (potency) and not more than 1020 μ g (potency) per mg, calculated on the anhydrous basis. The potency of Erythromycin is expressed as mass (potency) of erythromycin ($C_{37}H_{67}NO_{13}$).

Description Erythromycin occurs as a white to light yellow-white powder.

It is freely soluble in methanol and in ethanol (95), and very slightly soluble in water.

Identification (1) Determine the infrared absorption spectrum of Erythromycin as directed in the potassium bromide disk method under Infrared Spectrophotometry <2.25>, and compare the spectrum with the Reference Spectrum or the spectrum of Erythromycin RS: both spectra exhibit similar intensities of absorption at the same wave numbers.

(2) Dissolve 10 mg each of Erythromycin and Erythromycin RS in 1 mL of methanol, and use these solutions as the sample solution and standard solution. Perform the test with these solutions as directed under Thin-layer Chromatography <2.03>. Spot 5 μ L each of the sample solution and standard solution on a plate of silica gel for thin-layer chromatography. Develop the plate with a mixture of methanol and ammonia solution (28) (50:1) to a distance of about 10

cm, and air-dry the plate. Spray evenly 4-methoxybenzaldehyde-sulfuric acid TS on the plate, and heat at 100°C for 15 minutes: the principal spot from the sample solution and the spot from the standard solution are dark purple in color, and their *R_f* values are the same.

Optical rotation <2.49> $[\alpha]_D^{20}$: -71 - -78° (1 g calculated on the anhydrous basis, ethanol (95), 50 mL, 100 mm).

Purity (1) Heavy metals <1.07>—Proceed with 1.0 g of Erythromycin according to Method 4, and perform the test. Prepare the control solution with 2.0 mL of Standard Lead Solution (not more than 20 ppm).

(2) Related substances—Dissolve 40 mg of Erythromycin in 2 mL of methanol, add a mixture of phosphate buffer solution (pH 7.0) and methanol (15:1) to make exactly 10 mL, and use this solution as the sample solution. Separately, dissolve 16 mg of Erythromycin RS in 2 mL of methanol, add a mixture of phosphate buffer solution (pH 7.0) and methanol (15:1) to make exactly 10 mL, and use this solution as the standard stock solution. Dissolve 5 mg each of erythromycin B and erythromycin C in 2 mL of methanol, add exactly 2 mL of the standard stock solution, add a mixture of phosphate buffer solution (pH 7.0) and methanol (15:1) to make exactly 25 mL, and use this solution as the standard solution. Perform the test with exactly 100 μ L each of the sample solution and standard solution as directed under Liquid Chromatography <2.01> according to the following conditions, and determine each peak area by the automatic integration method: the peak areas of erythromycin B and erythromycin C obtained from the sample solution are not larger than those of erythromycin B and erythromycin C from the standard solution, respectively, and the area of the peaks other than erythromycin, erythromycin B and erythromycin C from the sample solution is not larger than the peak area of erythromycin from the standard solution.

Operating conditions—

Detector: An ultraviolet absorption photometer (wavelength: 215 nm).

Column: A stainless steel column 4.6 mm in inside diameter and 25 cm in length, packed with styrene-divinylbenzene copolymer for liquid chromatography (8 μ m in particle diameter).

Column temperature: A constant temperature of about 70°C.

Mobile phase: Dissolve 3.5 g of dipotassium hydrogen phosphate in water to make 100 mL, and adjust the pH to 9.0 with diluted phosphoric acid (1 in 10). To 50 mL of this solution add 190 mL of *t*-butyl alcohol, 30 mL of acetonitrile and water to make 1000 mL.

Flow rate: Adjust so that the retention time of erythromycin is about 20 minutes.

Time span of measurement: About 4 times as long as the retention time of erythromycin, beginning after the solvent peak.

System suitability—

System performance: Dissolve 2 mg of *N*-demethylerythromycin in 10 mL of the standard solution. When the procedure is run with 100 μ L of this solution under the above operating conditions, *N*-demethylerythromycin, erythromycin C, erythromycin and erythromycin B are eluted in this order, with the resolution between the peaks of *N*-demethylerythromycin and erythromycin C being not less than 0.8 and with the resolution between the peaks of *N*-demethylerythromycin and erythromycin being not less than 5.5.

System repeatability: When the test is repeated 3 times with 100 μ L of the standard solution under the above operat-

ing conditions, the relative standard deviation of the peak area of erythromycin is not more than 3.0%.

Water <2.48> Not more than 10.0% (0.2 g, volumetric titration, direct titration).

Residue on ignition <2.44> Not more than 0.2% (1 g).

Assay Perform the test according to the Cylinder-plate method as directed under Microbial Assay for Antibiotics <4.02> according to the following conditions.

(i) Test organism—*Staphylococcus aureus* ATCC 6538 P

(ii) Culture medium—Use the medium i in 3) Medium for other organisms under (1) Agar media for seed and base layer. Adjust the pH of the medium so that it will be 7.8 to 8.0 after sterilization.

(iii) Standard solutions—Weigh accurately an amount of Erythromycin RS, equivalent to about 25 mg (potency), dissolve in 25 mL of methanol, add 0.1 mol/L phosphate buffer solution (pH 8.0) to make exactly 100 mL, and use this solution as the standard stock solution. Keep the standard stock solution at 5°C or below, and use within 7 days. Take exactly a suitable amount of the standard stock solution before use, add 0.1 mol/L phosphate buffer solution (pH 8.0) to make solutions so that each mL contains 20 µg (potency) and 5 µg (potency), and use these solutions as the high concentration standard solution and the low concentration standard solution, respectively.

(iv) Sample solutions—Weigh accurately an amount of Erythromycin, equivalent to about 25 mg (potency), dissolve in 25 mL of methanol, and add 0.1 mol/L phosphate buffer solution (pH 8.0) to make exactly 100 mL. Take exactly a suitable amount of this solution, add 0.1 mol/L phosphate buffer solution (pH 8.0) to make solutions so that each mL contains 20 µg (potency) and 5 µg (potency), and use these solutions as the high concentration sample solution and the low concentration sample solution, respectively.

Containers and storage Containers—Well-closed containers.

Erythromycin Delayed-release Tablets

エリスロマイシン腸溶錠

Erythromycin Delayed-release Tablets contain not less than 90.0% and not more than 110.0% of the labeled potency of erythromycin ($C_{37}H_{67}NO_{13}$: 733.93).

Method of preparation Prepare as directed under Tablets, with Erythromycin.

Identification To a quantity of powdered Erythromycin Delayed-release Tablets, equivalent to 10 mg (potency) of Erythromycin, add 1 mL of methanol, shake well, filter, and use the filtrate as the sample solution. Separately, dissolve 10 mg of Erythromycin RS in 1 mL of methanol, and use this solution as the standard solution. Then, proceed as directed in the Identification (2) under Erythromycin.

Loss on drying <2.41> Not more than 10.0% (0.2 g, in vacuum not exceeding 0.67 kPa, 60°C, 3 hours).

Uniformity of dosage units <6.02> It meets the requirement of the Mass variation test.

Disintegration <6.09> It meets the requirement. For the test

with 2nd fluid for disintegration test, use the disk.

Assay Perform the test according to the Cylinder-plate method as directed under Microbial Assay for Antibiotics <4.02> according to the following conditions.

(i) Test organism, culture medium, and standard solutions—Proceed as directed in the Assay under Erythromycin.

(ii) Sample solutions—Weigh accurately the mass of not less than 20 Erythromycin Delayed-release Tablets, and powder. Weigh accurately a portion of the powder, equivalent to about 25 mg (potency) of Erythromycin, add 25 mL of methanol, shake vigorously, add 0.1 mol/L phosphate buffer solution (pH 8.0) to make exactly 100 mL, and filter. Take exactly an appropriate volume of the filtrate, add 0.1 mol/L phosphate buffer solution (pH 8.0) to prepare solutions containing 20 µg (potency) and 5 µg (potency) per mL, and use these solutions as the high and the low concentration sample solutions, respectively.

Containers and storage Containers—Well-closed containers.

Erythromycin Ethylsuccinate

エリスロマイシンエチルコハク酸エステル

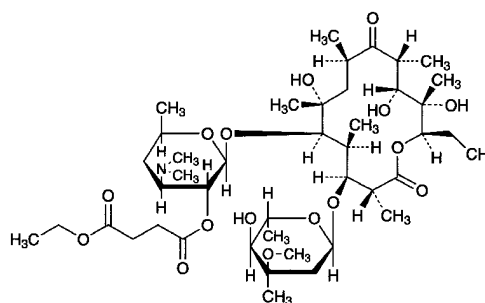

$C_{43}H_{75}NO_{16}$: 862.05

(2*R*,3*S*,4*S*,5*R*,6*R*,8*R*,10*R*,11*R*,12*S*,13*R*)-5-[3,4,6-Trideoxy-2-*O*-(3-ethoxycarbonylpropanoyl)-3-dimethylamino-β-*D*-xylo-hexopyranosyloxy]-3-(2,6-dideoxy-3-*C*-methyl-3-*O*-methyl-α-*L*-ribo-hexopyranosyloxy)-6,11,12-trihydroxy-2,4,6,8,10,12-hexamethyl-9-oxopentadecan-13-olide [41342-53-4]

Erythromycin Ethylsuccinate is a derivative of erythromycin.

It contains not less than 780 µg (potency) and not more than 900 µg (potency) per mg, calculated on the anhydrous basis. The potency of Erythromycin Ethylsuccinate is expressed as mass (potency) of erythromycin ($C_{37}H_{67}NO_{13}$: 733.93).

Description Erythromycin Ethylsuccinate occurs as a white powder.

It is freely soluble in methanol and in acetone, soluble in ethanol (95), and practically insoluble in water.

Identification (1) Dissolve 3 mg of Erythromycin Ethylsuccinate in 2 mL of acetone, and add 2 mL of hydrochloric acid: an orange color develops and is immediately changed to red to deep purple.

(2) Determine the infrared absorption spectrum of Erythromycin Ethylsuccinate, previously dried in a desiccator (reduced pressure, silica gel) for 24 hours, as directed in the potassium bromide disk method under Infrared Spectro-

photometry <2.25>, and compare the spectrum with the Reference Spectrum: both spectra exhibit similar intensities of absorption at the same wave numbers.

Water <2.48> Not more than 5.0% (0.5 g, volumetric titration, direct titration).

Assay Perform the test according to the Cylinder-plate method as directed under Microbial Assay for Antibiotics <4.02> according to the following conditions.

(i) Test organism—*Staphylococcus aureus* ATCC 6538 P

(ii) Culture medium—Use the medium i in 3) Medium for other organisms under (1) Agar media for seed and base layer. Adjust the pH of the medium so that it will be 7.8 to 8.0 after sterilization.

(iii) Standard solutions—Weigh accurately an amount of Erythromycin RS, equivalent to about 50 mg (potency), dissolve in 50 mL of methanol, add 0.1 mol/L phosphate buffer solution (pH 8.0) to make exactly 100 mL, and use this solution as the standard stock solution. Keep the standard stock solution at 5°C or below and use within 7 days. Take exactly a suitable amount of the standard stock solution before use, add 0.1 mol/L phosphate buffer solution (pH 8.0) to make solutions so that each mL contains 20 µg (potency) and 5 µg (potency), and use these solutions as the high concentration standard solution and the low concentration standard solution, respectively.

(iv) Sample solutions—Weigh accurately an amount of Erythromycin Ethylsuccinate, equivalent to about 50 mg (potency), dissolve in 50 mL of methanol, and add 0.1 mol/L phosphate buffer solution (pH 8.0) to make exactly 100 mL. Take exactly a suitable amount of the solution, add 0.1 mol/L phosphate buffer solution (pH 8.0) to make solutions so that each mL contains 20 µg (potency) and 5 µg (potency), and use these solutions as the high concentration sample solution and the low concentration sample solution, respectively.

Containers and storage Containers—Tight containers.

Erythromycin Lactobionate

エリスロマイシンラクトビオン酸塩

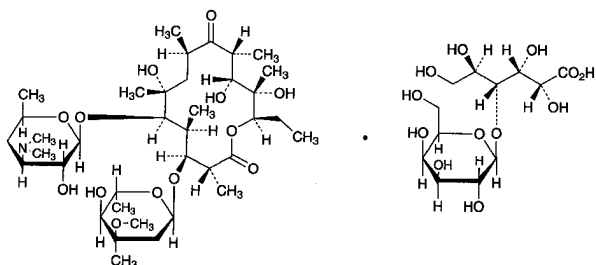

$C_{37}H_{67}NO_{13} \cdot C_{12}H_{22}O_{12}$: 1092.22

(2*R*,3*S*,4*S*,5*R*,6*R*,8*R*,10*R*,11*R*,12*S*,13*R*)-5-(3,4,6-Trideoxy-3-dimethylamino-β-D-xylo-hexopyranosyloxy)-3-(2,6-dideoxy-3-C-methyl-3-O-methyl-α-L-ribo-hexopyranosyloxy)-6,11,12-trihydroxy-2,4,6,8,10,12-hexamethyl-9-oxopentadecan-13-olide mono(4-O-β-D-galactopyranosyl-D-gluconate)
[3847-29-8]

Erythromycin Lactobionate is the lactobionate of erythromycin.

It contains not less than 590 µg (potency) and not more than 700 µg (potency) per mg, calculated on the anhydrous basis. The potency of Erythromycin Lac-

tobionate is expressed as mass (potency) of erythromycin ($C_{37}H_{67}NO_{13}$: 733.93).

Description Erythromycin Lactobionate occurs as a white powder.

It is freely soluble in water, in methanol and in ethanol (99.5), and very slightly soluble in acetone.

Identification (1) To 3 mg of Erythromycin Lactobionate add 2 mL of acetone, and add 2 mL of hydrochloric acid: an orange color is produced, and it changes immediately to red to deep purple.

(2) Transfer about 0.3 g of Erythromycin Lactobionate to a separator, add 15 mL of ammonia TS and 15 mL of chloroform, shake, and take the separated aqueous layer. Wash the aqueous layer with three 15-mL portions of chloroform, and evaporate the aqueous liquid on a water bath to dryness. Dissolve the residue in 10 mL of a mixture of methanol and water (3:2), and use this solution as the sample solution. Separately, dissolve 0.10 g of lactobionic acid in 10 mL of a mixture of methanol and water (3:2), and use this solution as the standard solution. Perform the test with these solutions as directed under Thin-layer Chromatography <2.03>. Spot 10 µL each of the sample solution and standard solution on a plate of silica gel for thin-layer chromatography. Develop the plate with the upper layer obtained from a mixture of water, 1-butanol and acetic acid (100) (3:3:1) to a distance of about 10 cm, and air-dry the plate. Spray evenly dilute sulfuric acid, and heat at 105°C for 20 minutes: the principal spot obtained from the sample solution shows a deep brown and the *R_f* value which are the same as those of the principal spot from the standard solution.

pH <2.54> The pH of a solution obtained by dissolving 0.5 g of Erythromycin Lactobionate in 10 mL of water is between 5.0 and 7.5.

Water <2.48> Not more than 5.0% (0.5 g, volumetric titration, direct titration).

Assay Perform the test according to the Cylinder-plate method as directed under Microbial Assay for Antibiotics <4.02> according to the following conditions.

(i) Test organism—*Staphylococcus aureus* ATCC 6538 P

(ii) Culture medium—Use the medium i in 3) Medium for other organisms under (1) Agar media for seed and base layer. Adjust the pH of the medium so that it will be 7.8 to 8.0 after sterilization.

(iii) Standard solutions—Weigh accurately an amount of Erythromycin RS, equivalent to about 50 mg (potency), dissolve in 50 mL of methanol, add 0.1 mol/L phosphate buffer solution (pH 8.0) to make exactly 100 mL, and use this solution as the standard stock solution. Keep the standard stock solution at not exceeding 5°C and use within 7 days. Take exactly a suitable amount of the standard stock solution before use, add 0.1 mol/L phosphate buffer solution (pH 8.0) to make solutions so that each mL contains 20 µg (potency) and 5 µg (potency), and use these solutions as the high concentration standard solution and the low concentration standard solution, respectively.

(iv) Sample solutions—Weigh accurately an amount of Erythromycin Lactobionate, equivalent to about 50 mg (potency), dissolve in 50 mL of methanol, and add 0.1 mol/L phosphate buffer solution (pH 8.0) to make exactly 100 mL. Take exactly a suitable amount of this solution, add 0.1 mol/L phosphate buffer solution (pH 8.0) to make solutions so that each mL contains 20 µg (potency) and 5 µg (potency), and use these solutions as the high concentration sample

solution and the low concentration sample solution, respectively.

Containers and storage Containers—Tight containers.

Erythromycin Stearate

エリスロマイシステアリン酸塩

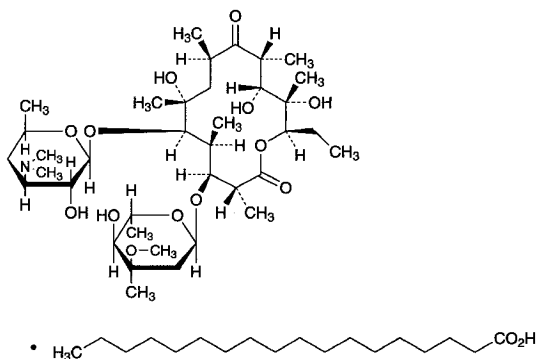

$C_{37}H_{67}NO_{13} \cdot C_{18}H_{36}O_2$: 1018.40

(2*R*,3*S*,4*S*,5*R*,6*R*,8*R*,10*R*,11*R*,12*S*,13*R*)-5-(3,4,6-Trideoxy-3-dimethylamino- β -D-xylohexopyranosyloxy)-3-(2,6-dideoxy-3-C-methyl-3-O-methyl- α -L-ribo-hexopyranosyloxy)-6,11,12-trihydroxy-2,4,6,8,10,12-hexamethyl-9-oxopentadecan-13-olide monostearate
[643-22-1]

Erythromycin Stearate is the stearate of erythromycin.

It contains not less than 600 μ g (potency) and not more than 720 μ g (potency) per mg, calculated on the anhydrous basis. The potency of Erythromycin Stearate is expressed as mass (potency) of erythromycin ($C_{37}H_{67}NO_{13}$: 733.93).

Description Erythromycin Stearate occurs as a white powder.

It is freely soluble in ethanol (95) and in acetone, soluble in methanol, and practically insoluble in water.

Identification (1) Dissolve 3 mg of Erythromycin Stearate in 2 mL of acetone, and add 2 mL of hydrochloric acid: an orange color develops and is immediately changed to red to deep purple.

(2) Determine the infrared absorption spectrum of Erythromycin Stearate, previously dried in a desiccator (reduced pressure, silica gel) for 24 hours, as directed in the potassium bromide disk method under Infrared Spectrophotometry <2.25>, and compare the spectrum with the Reference Spectrum: both spectra exhibit similar intensities of absorption at the same wave numbers.

Water <2.48> Not more than 5.0% (0.5 g, volumetric titration, direct titration).

Assay Perform the test according to the Cylinder-plate method as directed under Microbial Assay for Antibiotics <4.02> according to the following conditions.

- (i) Test organism—*Staphylococcus aureus* ATCC 6538 P
- (ii) Culture medium—Use the medium i in 3) Medium for other organisms under (1) Agar media for seed and base layer. Adjust the pH of the medium so that it will be 7.8 to 8.0 after sterilization.
- (iii) Standard solutions—Weigh accurately an amount of

Erythromycin RS equivalent to about 50 mg (potency), dissolve in 50 mL of methanol, add 0.1 mol/L phosphate buffer solution (pH 8.0) to make exactly 100 mL, and use this solution as the standard stock solution. Keep the standard stock solution at 5°C or below and use within 7 days. Take exactly a suitable amount of the standard stock solution before use, add 0.1 mol/L phosphate buffer solution (pH 8.0) to make solutions so that each mL contains 20 μ g (potency) and 5 μ g (potency), and use these solutions as the high concentration standard solution and the low concentration standard solution, respectively.

(iv) Sample solutions—Weigh accurately an amount of Erythromycin Stearate equivalent to about 50 mg (potency), dissolve in 50 mL of methanol, and add 0.1 mol/L phosphate buffer solution (pH 8.0) to make exactly 100 mL. Take exactly a suitable amount of the solution, add 0.1 mol/L phosphate buffer solution (pH 8.0) to make solutions so that each mL contains 20 μ g (potency) and 5 μ g (potency), and use these solutions as the high concentration sample solution and the low concentration sample solution, respectively.

Containers and storage Containers—Tight containers.

Estazolam

エスタゾラム

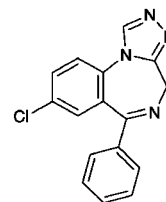

$C_{16}H_{11}ClN_4$: 294.74

8-Chloro-6-phenyl-4*H*-[1,2,4]triazolo[4,3-*a*][1,4]benzodiazepine
[29975-16-4]

Estazolam, when dried, contains not less than 98.5% of estazolam ($C_{16}H_{11}ClN_4$).

Description Estazolam occurs as white to pale yellow-white, crystals or crystalline powder. It is odorless, and has a bitter taste.

It is soluble in methanol and in acetic anhydride, sparingly soluble in ethanol (95), and practically insoluble in water and in diethyl ether.

Identification (1) Dissolve 0.01 g of Estazolam in 3 mL of sulfuric acid: the solution shows a yellow-green fluorescence under ultraviolet light (main wavelength: 365 nm).

(2) Determine the absorption spectrum of a solution of Estazolam in 1 mol/L hydrochloric acid TS (1 in 100,000) as directed under Ultraviolet-visible Spectrophotometry <2.24>, and compare the spectrum with the Reference Spectrum: both spectra exhibit similar intensities of absorption at the same wavelengths.

(3) Perform the test with Estazolam as directed under Flame Coloration Test <1.04> (2): a green color appears.

Melting point <2.60> 229 – 233°C

Purity (1) Clarity and color of solution—Dissolve 0.10 g of Estazolam in 10 mL of ethanol (95): the solution is clear and colorless.

(2) Chloride <1.03>—Dissolve 1.0 g of Estazolam in 10 mL of ethanol (95) by heating, add 40 mL of water, cool

with shaking in ice water, allow to stand to attain ordinary temperature, and filter. To 30 mL of the filtrate add 6 mL of dilute nitric acid and water to make 50 mL, and perform the test using this solution as the test solution. Prepare the control solution with 0.25 mL of 0.01 mol/L hydrochloric acid VS and 6 mL of ethanol (95) (not more than 0.015%).

(3) Heavy metals <1.07>—Proceed with 1.0 g of Estazolam according to Method 2, and perform the test. Prepare the control solution with 2.0 mL of Standard Lead Solution (not more than 20 ppm).

(4) Arsenic <1.11>—Prepare the test solution with 1.0 g of Estazolam according to Method 3, and perform the test (not more than 2 ppm).

(5) Related substances—Dissolve 0.20 g of Estazolam in 10 mL of methanol, and use this solution as the sample solution. Pipet 1 mL of the sample solution, add methanol to make exactly 200 mL, and use this solution as the standard solution. Perform the test with these solutions as directed under Thin-layer Chromatography <2.03>. Spot 10 μ L each of the sample solution and standard solution on a plate of silica gel with fluorescent indicator for thin-layer chromatography. Develop the plate with a mixture of hexane, chloroform and methanol (5:3:1) to a distance of about 10 cm, and air-dry the plate. Examine the plate under ultraviolet light (main wavelength: 254 nm): the spots other than the principal spot obtained from the sample solution are not more intense than the principal spot from the standard solution.

Loss on drying <2.41> Not more than 1.0% (1 g, 105°C, 4 hours).

Residue on ignition <2.44> Not more than 0.1% (2 g).

Assay Weigh accurately about 0.25 g of Estazolam, previously dried, dissolve in 100 mL of acetic anhydride, and titrate <2.50> with 0.1 mol/L perchloric acid VS (potentiometric titration), until the solution changes to the second equivalence point. Perform a blank determination in the same manner, and make any necessary correction.

$$\begin{aligned} \text{Each mL of 0.1 mol/L perchloric acid VS} \\ = 14.74 \text{ mg of } C_{16}H_{11}ClN_4 \end{aligned}$$

Containers and storage Containers—Well-closed containers.

Estradiol Benzoate

エストラジオール安息香酸エステル

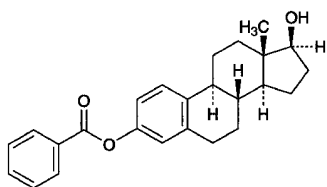

$C_{25}H_{28}O_3$; 376.49

Estra-1,3,5(10)-triene-3,17 β -diol 3-benzoate
[50-50-0]

Estradiol Benzoate, when dried, contains not less than 97.0% of estradiol benzoate ($C_{25}H_{28}O_3$).

Description Estradiol Benzoate occurs as a white crystalline powder. It is odorless.

It is sparingly soluble in acetone, slightly soluble in methanol, in ethanol (95) and in diethyl ether, and practically in-

soluble in water.

Identification (1) To 2 mg of Estradiol Benzoate add 2 mL of sulfuric acid: a yellowish green color with a blue fluorescence is produced, and the color of the solution changes to light orange on the careful addition of 2 mL of water.

(2) Determine the infrared absorption spectrum of Estradiol Benzoate, previously dried, as directed in the potassium bromide disk method under Infrared Spectrophotometry <2.25>, and compare the spectrum with the Reference Spectrum or the spectrum of dried Estradiol Benzoate RS: both spectra exhibit similar intensities of absorption at the same wave numbers.

Optical rotation <2.49> $[\alpha]_D^{20}$: +54 – +58° (after drying, 0.1 g, acetone, 10 mL, 100 mm).

Melting point <2.60> 191 – 198°C

Purity (1) 3,17 α -Estradiol—Dissolve 5.0 mg each of Estradiol Benzoate and Estradiol Benzoate RS in acetone to make exactly 100 mL, and use these solutions as the sample solution and the standard solution, respectively. Place exactly 2 mL each of the sample solution and standard solution in separate glass-stoppered test tube, add boiling stones, evaporate the acetone by heating in a water bath, and dry the residue in a desiccator (in vacuum, phosphorus (V) oxide) for 1 hour. Add 1.0 mL of dilute iron-phenol TS to each test tube. Stopper the test tubes loosely, heat for 30 seconds in a water bath, shake in a water bath for several seconds, and heat for 2 minutes. Cool the solutions in ice for 2 minutes, add 4.0 mL of diluted sulfuric acid (7 in 20), and mix well: the solution obtained from the sample solution has no more color than that from the standard solution.

(2) Related substances—Dissolve 40 mg of Estradiol Benzoate in 2 mL of acetone, and use this solution as the sample solution. Pipet 1 mL of the sample solution, add acetone to make exactly 100 mL, and use this solution as the standard solution. Perform the test with these solutions as directed under Thin-layer Chromatography <2.03>. Spot 10 μ L each of the sample solution and standard solution on a plate of silica gel with fluorescent indicator for thin-layer chromatography. Develop the plate with a mixture of chloroform and diethylamine (19:1) to a distance of about 15 cm, and air-dry the plate. Examine under ultraviolet light (main wavelength: 254 nm): the spots other than the principal spot obtained from the sample solution are not more intense than the spot from the standard solution.

Loss on drying <2.41> Not more than 0.5% (0.5 g, in vacuum, phosphorus (V) oxide, 4 hours).

Residue on ignition <2.44> Not more than 0.2% (0.1 g).

Assay Weigh accurately about 10 mg each of Estradiol Benzoate and Estradiol Benzoate RS, previously dried, and dissolve each in methanol to make exactly 20 mL. Pipet 5 mL each of these solutions, add 5 mL of the internal standard solution, then add methanol to make 20 mL, and use these solutions as the sample solution and the standard solution, respectively. Perform the test with 5 μ L of the sample solution and standard solution as directed under Liquid Chromatography <2.01> according to the following conditions, and calculate the ratios, Q_T and Q_S , of the peak area of estradiol benzoate to that of the internal standard.

$$\begin{aligned} \text{Amount (mg) of estradiol benzoate (} C_{25}H_{28}O_3 \text{)} \\ = M_S \times Q_T / Q_S \end{aligned}$$

M_S : Amount (mg) of Estradiol Benzoate RS taken

Internal standard solution—A solution of progesterone in methanol (13 in 80,000).

Operating conditions—

Detector: An ultraviolet absorption photometer (wavelength: 230 nm).

Column: A stainless steel column 4.6 mm in inside diameter and 15 cm in length, packed with octadecylsilanized silica gel for liquid chromatography (5 μm in particle diameter).

Column temperature: A constant temperature of about 35°C.

Mobile phase: A mixture of acetonitrile and water (7:3).

Flow rate: Adjust so that the retention time of estradiol benzoate is about 10 minutes.

System suitability—

System performance: When the procedure is run with 5 μL of the standard solution under the above operating conditions, the internal standard and estradiol benzoate are eluted in this order with the resolution between these peaks being not less than 9.

System repeatability: When the test is repeated 6 times with 5 μL of the standard solution under the above operating conditions, the relative standard deviation of the ratios of the peak area of estradiol benzoate to that of the internal standard is not more than 1.0%.

Containers and storage Containers—Tight containers.

Storage—Light-resistant.

Estradiol Benzoate Injection (Aqueous Suspension)

エストラジオール安息香酸エステル水性懸濁注射液

Estradiol Benzoate Injection (Aqueous Suspension) is an aqueous suspension for injection.

It contains not less than 90.0% and not more than 110.0% of the labeled amount of estradiol benzoate (C₂₅H₂₈O₃: 376.49).

Method of preparation Prepare as directed under Injection, with Estradiol Benzoate.

Description Estradiol Benzoate Injection (Aqueous Suspension) produces a white turbidity on shaking.

Identification Extract a volume of Estradiol Benzoate Injection (Aqueous Suspension), equivalent to 1 mg of Estradiol Benzoate, with 5 mL of chloroform, and use this extract as the sample solution. Separately, dissolve 1 mg of Estradiol Benzoate RS in 5 mL of chloroform, and use this solution as the standard solution. Perform the test with these solutions as directed under Thin-layer Chromatography <2.03>. Spot 50 μL each of the sample solution and standard solution on a plate of silica gel with fluorescent indicator for thin-layer chromatography. Develop the plate with a mixture of chloroform and methanol (99:1) to a distance of about 15 cm, and air-dry the plate. Examine under ultraviolet light (main wavelength: 254 nm): the principal spot obtained from the sample solution and the spot from the standard solution show the same R_f value.

Extractable volume <6.05> It meets the requirement.

Foreign insoluble matter <6.06> Perform the test according to Method 1: it meets the requirement.

Sterility <4.06> Perform the test according to the Direct inoculation method: it meets the requirement.

Assay Measure exactly a volume of well-mixed Estradiol Benzoate Injection (Aqueous Suspension), equivalent to about 2 mg of estradiol benzoate (C₂₅H₂₈O₃), dissolve the crystals with an appropriate quantity of methanol, and add methanol to make exactly 20 mL. Pipet 10 mL of this solution, add exactly 10 mL of the internal standard solution, add methanol to make 100 mL, and use this solution as the sample solution. Separately, weigh accurately about 10 mg of Estradiol Benzoate RS, previously dried in desiccator (reduced pressure, phosphorus (V) oxide) for 4 hours, and dissolve in methanol to make exactly 100 mL. Pipet 10 mL of this solution, add exactly 10 mL of the internal standard solution and methanol to make 100 mL, and use this solution as the standard solution. Proceed with these solutions as directed in the Assay under Estradiol Benzoate.

$$\begin{aligned} & \text{Amount (mg) of estradiol benzoate (C}_{25}\text{H}_{28}\text{O}_3) \\ & = M_S \times Q_T / Q_S \times 1/5 \end{aligned}$$

M_S: Amount (mg) of Estradiol Benzoate RS taken

Internal standard solution—A solution of progesterone in methanol (13 in 100,000).

Containers and storage Containers—Hermetic containers.

Estriol

エストリオール

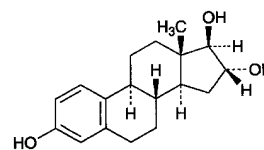

C₁₈H₂₄O₃: 288.38

Estra-1,3,5(10)-triene-3,16α,17β-triol
[50-27-1]

Estriol, when dried, contains not less than 97.0% and not more than 102.0% of estriol (C₁₈H₂₄O₃).

Description Estriol occurs as a white crystalline powder. It is odorless.

It is sparingly soluble in methanol, slightly soluble in ethanol (99.5), and practically insoluble in water.

Identification (1) Dissolve 0.01 g of Estriol in 100 mL of ethanol (95) by warming, and use this solution as the sample solution. Evaporate 1 mL of the sample solution on a water bath to dryness, add 5 mL of a solution of sodium *p*-phenol-sulfonate in diluted phosphoric acid (1 in 50), heat at 150°C for 10 minutes, and cool: a red-purple color develops.

(2) Determine the absorption spectrum of the sample solution obtained in (1) as directed under Ultraviolet-visible Spectrophotometry <2.24>, and compare the spectrum with the Reference Spectrum or the spectrum of a solution of Estriol RS prepared in the same manner as the sample solution: both spectra exhibit similar intensities of absorption at the same wavelengths.

(3) Determine the infrared absorption spectrum of Estriol, previously dried, as directed in the potassium bromide disk method under Infrared Spectrophotometry <2.25>, and compare the spectrum with the Reference Spectrum or the spectrum of previously dried Estriol RS: both spectra exhibit similar intensities of absorption at the same wave numbers.

Optical rotation <2.49> [α]_D²⁵: +55 – +65° (after drying, 40

mg, ethanol (99.5), 10 mL, 100 mm).

Melting point <2.60> 281 – 286°C

Purity (1) Heavy metals <1.07>—Proceed with 1.0 g of Estriol according to Method 2, and perform the test. Prepare the control solution with 2.0 mL of Standard Lead Solution (not more than 20 ppm).

(2) Related substances—Dissolve 40 mg of Estriol in 10 mL of ethanol (95) by warming, and use this solution as the sample solution. Pipet 1 mL of the sample solution, add ethanol (95) to make exactly 100 mL, and use this solution as the standard solution. Perform the test with these solutions as directed under Thin-layer Chromatography <2.03>. Spot 5 μ L each of the sample solution and standard solution on a plate of silica gel for thin-layer chromatography. Develop the plate with a mixture of chloroform, methanol, acetone and acetic acid (100) (18:1:1:1) to a distance of about 15 cm, and air-dry the plate. Spray evenly diluted sulfuric acid (1 in 2) on the plate, and heat at 105°C for 15 minutes: the spots other than the principal spot obtained from the sample solution are not more intense than the spot from the standard solution.

Loss on drying <2.41> Not more than 0.5% (0.5 g, 105°C, 3 hours).

Residue on ignition <2.44> Not more than 0.1% (0.5 g).

Assay Weigh accurately about 25 mg each of Estriol and Estriol RS, previously dried, and dissolve each in methanol to make exactly 50 mL. Pipet 10 mL each of these solutions, add exactly 5 mL of the internal standard solution, add methanol to make 100 mL, and use these solutions as the sample solution and the standard solution, respectively. Perform the test with 10 μ L each of the sample solution and standard solution as directed under Liquid Chromatography <2.01> according to the following conditions, and calculate the ratios, Q_T and Q_S , of the peak area of estriol to that of the internal standard.

$$\text{Amount (mg) of estriol (C}_{18}\text{H}_{24}\text{O}_3) = M_S \times Q_T/Q_S$$

M_S : Amount (mg) of Estriol RS taken

Internal standard solution—A solution of methyl benzoate for estriol test in methanol (1 in 1000).

Operating conditions—

Detector: An ultraviolet absorption photometer (wavelength: 280 nm).

Column: A stainless steel column 4.6 mm in inside diameter and 15 cm in length, packed with octadecylsilanized silica gel for liquid chromatography (5 μ m in particle diameter).

Column temperature: A constant temperature of about 25°C.

Mobile phase: A mixture of water and methanol (51:49).

Flow rate: Adjust so that the retention time of estriol is about 10 minutes.

System suitability—

System performance: When the procedure is run with 10 μ L of the standard solution under the above operating conditions, estriol and the internal standard are eluted in this order with the resolution between these peaks being not less than 8.

System repeatability: When the test is repeated 6 times with 10 μ L of the standard solution under the above operating conditions, the relative standard deviation of the ratios of the peak area of estriol to that of the internal standard is not more than 1.0%.

Containers and storage Containers—Tight containers.

Estriol Injection (Aqueous Suspension)

エストリオール水性懸濁注射液

Estriol Injection (Aqueous Suspension) is an aqueous suspension for injection.

It contains not less than 90.0% and not more than 110.0% of the labeled amount of estriol (C₁₈H₂₄O₃; 288.38).

Method of preparation Prepare as directed under Injections, with Estriol.

Description Shake Estriol Injection (Aqueous Suspension): a white turbidity is produced.

Identification (1) Shake well, take a volume of Estriol Injection (Aqueous Suspension), equivalent to 2 mg of Estriol, add ethanol (95) to make 20 mL, and use this solution as the sample solution. Proceed with the sample solution as directed in the Identification (1) under Estriol.

(2) Determine the absorption spectrum of the sample solution obtained in (1) as directed under Ultraviolet-visible Spectrophotometry <2.24>: it exhibits a maximum between 279 nm and 283 nm.

Extractable volume <6.05> It meets the requirement.

Foreign insoluble matter <6.06> Perform the test according to Method 1: it meets the requirement.

Sterility <4.06> Perform the test according to the Direct inoculation method: it meets the requirement.

Assay Shake well, pipet a volume of Estriol Injection (Aqueous Suspension), equivalent to about 5 mg of estriol (C₁₈H₂₄O₃), and dissolve in methanol to make exactly 20 mL. Pipet 4 mL of this solution, add exactly 5 mL of the internal standard solution, then add methanol to make 50 mL, and use this solution as the sample solution. Separately, weigh accurately about 25 mg of Estriol RS, previously dried at 105°C for 3 hours, and dissolve in methanol to make exactly 100 mL. Pipet 4 mL of this solution, add exactly 5 mL of the internal standard solution, then add methanol to make 50 mL, and use this solution as the standard solution. Proceed as directed in the Assay under Estriol.

$$\begin{aligned} \text{Amount (mg) of estriol (C}_{18}\text{H}_{24}\text{O}_3) \\ = M_S \times Q_T/Q_S \times 1/5 \end{aligned}$$

M_S : Amount (mg) of Estriol RS taken

Internal standard solution—A solution of methyl benzoate for estriol test in ethanol (95) (1 in 5000).

Containers and storage Containers—Hermetic containers.

Estriol Tablets

エストリオール錠

Estriol Tablets contain not less than 90.0% and not more than 110.0% of the labeled amount of estriol (C₁₈H₂₄O₃; 288.38).

Method of preparation Prepare as directed under Tablets, with Estriol.

Identification (1) Weigh a portion of powdered Estriol

Tablets, equivalent to 2 mg of Estriol, add 20 mL of ethanol (95), shake for 10 minutes, centrifuge, and use the supernatant liquid as the sample solution. Proceed with the sample solution as directed in the Identification (1) under Estriol.

(2) Determine the absorption spectrum of the sample solution obtained in (1) as directed under Ultraviolet-visible Spectrophotometry <2.24>: it exhibits a maximum between 279 nm and 283 nm.

Uniformity of dosage units <6.02> Perform the test according to the following method: it meets the requirement of the Content uniformity test.

To 1 tablet of Estriol Tablets add exactly 5 mL of water, disperse the fine particles by sonicating, add exactly 15 mL of methanol, and shake for 15 minutes. Centrifuge this solution for 10 minutes, pipet a definite amount of the supernatant liquid, and add methanol to make exactly a definite amount of solution so that each mL of the solution contains about 5 µg of estriol (C₁₈H₂₄O₃). Pipet 5 mL of this solution, add exactly 1 mL of the internal standard solution, and use this solution as the sample solution. Proceed with 20 µL of the sample solution as directed in the Assay under Estriol. Use a solution of methyl benzoate for estriol test in methanol (1 in 40,000) as the internal standard solution. Calculate the mean value from each ratio of peak areas of 10 samples: the samples conform to the requirements if the deviation (%) of the mean value and each ratio of peak areas is within 15%. If the deviation (%) exceeds 15%, and 1 sample shows deviation within 25%, repeat the test with 20 samples. Calculate the deviation (%) of the mean value from each ratio of peak areas of the 30 samples used in the 2 tests and each ratio of peak areas: the samples conform to the requirements if the deviation exceeds 15%, not more than 1 sample shows deviation within 25%, and no sample shows deviation exceeding 25%.

Dissolution <6.10> When the test is performed at 50 revolutions per minute according to the Paddle method, using 900 mL of water as the dissolution medium, the dissolution rate in 30 minutes of Estriol Tablets is not less than 80%.

Start the test with 1 tablet of Estriol Tablets, withdraw not less than 20 mL of the medium at the specified minute after starting the test, and filter through a membrane filter with a pore size not exceeding 0.8 µm. Discard not less than 10 mL of the first filtrate, pipet *V* mL of the subsequent filtrate, add water to make exactly *V'* mL so that each mL contains about 0.1 µg of estriol (C₁₈H₂₄O₃), and use this solution as the sample solution. Separately, weigh accurately about 10 mg of Estriol RS, previously dried at 105°C for 3 hours, dissolve in methanol to make exactly 100 mL, then pipet 5 mL of this solution, and add water to make exactly 100 mL. Pipet 2 mL of this solution, add water to make exactly 100 mL, and use this solution as the standard solution. Perform the test with exactly 100 µL each of the sample solution and standard solution as directed under Liquid chromatography <2.01> according to the following conditions, and determine the peak areas, *A_T* and *A_S*, of estriol.

Dissolution rate (%) with respect to the labeled amount of estriol (C₁₈H₂₄O₃)

$$= M_S \times A_T / A_S \times V' / V \times 1 / C \times 9 / 10$$

M_S: Amount (mg) of Estriol RS taken

C: Labeled amount (mg) of estriol (C₁₈H₂₄O₃) in 1 tablet

Operating conditions—

Proceed as directed in the operating conditions in the Assay under Estriol.

System suitability—

Proceed as directed in the system suitability in the Assay under Estriol.

Assay Weigh accurately and powder not less than 20 Estriol Tablets. Weigh accurately a portion of the powder, equivalent to about 1 mg of estriol (C₁₈H₂₄O₃), add exactly 5 mL of water, disperse the fine particles by sonicating, shake with 25 mL of methanol for 10 minutes, centrifuge, and take the supernatant liquid. Add 25 mL of methanol, repeat the above procedure twice, combine the supernatant liquid, add exactly 5 mL of the internal standard solution, then add methanol to make 100 mL, and use this solution as the sample solution. Separately, weigh accurately about 25 mg of Estriol RS, previously dried at 105°C for 3 hours, and dissolve in methanol to make exactly 100 mL. Pipet 4 mL of this solution, add exactly 5 mL of the internal standard solution, then add methanol to make 100 mL, and use this solution as the standard solution. Proceed with 20 µL each of the sample solution and standard solution as directed in the Assay under Estriol.

$$\begin{aligned} &\text{Amount (mg) of estriol (C}_{18}\text{H}_{24}\text{O}_3) \\ &= M_S \times Q_T / Q_S \times 1 / 25 \end{aligned}$$

M_S: Amount (mg) of Estriol RS taken

Internal standard solution—A solution of methyl benzoate for estriol test in methanol (1 in 5000).

Containers and storage Containers—Tight containers.

Etacrylic Acid

エタクリン酸

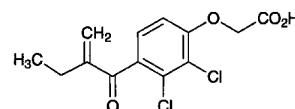

C₁₃H₁₂Cl₂O₄: 303.14

[2,3-Dichloro-4-(2-ethylacryloyl)phenoxy]acetic acid
[58-54-8]

Etacrylic Acid, when dried, contains not less than 98.0% of etacrylic acid (C₁₃H₁₂Cl₂O₄).

Description Etacrylic Acid occurs as a white crystalline powder. It is odorless, and has a slightly bitter taste.

It is very soluble in methanol, freely soluble in ethanol (95), in acetic acid (100) and in diethyl ether, and very slightly soluble in water.

Identification (1) Dissolve 0.2 g of Etacrylic Acid in 10 mL of acetic acid (100), and to 5 mL of this solution add 0.1 mL of bromine TS: the color of the test solution disappears. To the remaining 5 mL of the solution add 0.1 mL of potassium permanganate TS: the color of the test solution changes to light orange immediately.

(2) To 0.01 g of Etacrylic Acid add 1 mL of sodium hydroxide TS, and heat in a water bath for 3 minutes. After cooling, add 1 mL of chromotropic acid TS, and heat in a water bath for 10 minutes: a deep purple color develops.

(3) Determine the absorption spectrum of a solution of Etacrylic Acid in methanol (1 in 20,000) as directed under Ultraviolet-visible Spectrophotometry <2.24>, and compare the spectrum with the Reference Spectrum: both spectra exhibit similar intensities of absorption at the same wavelengths.

(4) Perform the test with Etacrynic Acid as directed under Flame Coloration Test <1.04> (2): a green color appears.

Melting point <2.60> 121 – 125°C

Purity (1) Clarity and color of solution—Dissolve 1.0 g of Etacrynic Acid in 10 mL of methanol: the solution is clear and colorless.

(2) Heavy metals <1.07>—Proceed with 1.0 g of Etacrynic Acid according to Method 4, and perform the test. Prepare the control solution with 2.0 mL of Standard Lead Solution (not more than 20 ppm).

(3) Arsenic <1.11>—Prepare the test solution with 1.0 g of Etacrynic Acid according to Method 3, and perform the test. Add 10 mL of a solution of magnesium nitrate hexahydrate in ethanol (95) (1 in 50), then add 1.5 mL of hydrogen peroxide (30), and fire to burn (not more than 2 ppm).

(4) Related substances—Dissolve 0.20 g of Etacrynic Acid in 10 mL of ethanol (95), and use this solution as the sample solution. Pipet 3 mL of the sample solution, add ethanol (95) to make exactly 200 mL, and use this solution as the standard solution. Perform the test with these solutions as directed under Thin-layer Chromatography <2.03>. Spot 10 μ L each of the sample solution and standard solution on a plate of silica gel with fluorescent indicator for thin-layer chromatography. Develop the plate with a mixture of chloroform, ethyl acetate and acetic acid (100) (6:5:2) to a distance of about 15 cm, and air-dry the plate. Examine under ultraviolet light (main wavelength: 254 nm): the spots other than the principal spot obtained from the sample solution are not more intense than the spot from the standard solution.

Loss on drying <2.41> Not more than 0.25% (1 g, in vacuum, 60°C, 2 hours).

Residue on ignition <2.44> Not more than 0.1% (1 g).

Assay Weigh accurately about 0.1 g of Etacrynic Acid, previously dried, place in an iodine bottle, dissolve in 20 mL of acetic acid (100), and add exactly 20 mL of 0.05 mol/L bromine VS. To this solution add 3 mL of hydrochloric acid, stopper tightly at once, shake, and allow to stand in a dark place for 60 minutes. Add carefully 50 mL of water and 15 mL of potassium iodide TS, stopper tightly at once, shake well, and titrate <2.50> the liberated iodine with 0.1 mol/L sodium thiosulfate VS (indicator: 1 mL of starch TS). Perform a blank determination in the same manner.

$$\begin{aligned} \text{Each mL of 0.05 mol/L bromine VS} \\ = 15.16 \text{ mg of } C_{13}H_{12}Cl_2O_4 \end{aligned}$$

Containers and storage Containers—Well-closed containers.

Etacrynic Acid Tablets

エタクリン酸錠

Etacrynic Acid Tablets contain not less than 90.0% and not more than 110.0% of the labeled amount of etacrynic acid ($C_{13}H_{12}Cl_2O_4$: 303.14).

Method of preparation Prepare as directed under Tablets, with Etacrynic Acid.

Identification (1) Weigh a quantity of powdered Etacrynic Acid Tablets, equivalent to 0.3 g of Etacrynic Acid, add 25 mL of 0.1 mol/L hydrochloric acid TS, and extract

with 50 mL of dichloromethane. Filter the dichloromethane extract, and evaporate the filtrate on a water bath to dryness. Proceed with the residue as directed in the Identification (1), (2) and (4) under Etacrynic Acid.

(2) Prepare a solution of the residue obtained in (1), equivalent to a solution of Etacrynic Acid in methanol (1 in 20,000), and determine the absorption spectrum of this solution as directed under Ultraviolet-visible Spectrophotometry <2.24>: it exhibits a maximum between 268 nm and 272 nm.

Dissolution <6.10> When the test is performed at 50 revolutions per minute according to the Paddle method, using 900 mL of water as the dissolution medium, the dissolution rate in 45 minutes of Etacrynic Acid Tablets is not less than 70%.

Start the test with 1 tablet of Etacrynic Acid Tablets, withdraw not less than 20 mL of the medium at the specified minute after starting the test, and filter through a membrane filter with a pore size not exceeding 0.8 μ m. Discard not less than 10 mL of the first filtrate, pipet V mL of the subsequent filtrate, add water to make exactly V' mL so that each mL contains about 28 μ g of etacrynic acid ($C_{13}H_{12}Cl_2O_4$), and use this solution as the sample solution. Separately, weigh accurately about 55 mg of etacrynic acid for assay, previously dried in vacuum at 60°C for 2 hours, dissolve in 10 mL of methanol, and add water to make exactly 100 mL. Pipet 5 mL of this solution, add water to make exactly 100 mL, and use this solution as the standard solution. Determine the absorbances, A_T and A_S , at 277 nm of the sample solution and standard solution as directed under Ultraviolet-visible Spectrophotometry <2.24>, using water as the blank.

Dissolution rate (%) with respect to the labeled amount of etacrynic acid ($C_{13}H_{12}Cl_2O_4$)

$$= M_S \times A_T/A_S \times V'/V \times 1/C \times 45$$

M_S : Amount (mg) of etacrynic acid for assay taken

C : Labeled amount (mg) of etacrynic acid ($C_{13}H_{12}Cl_2O_4$) in 1 tablet

Assay Weigh accurately and powder not less than 20 Etacrynic Acid Tablets. Weigh accurately a portion of the powder, equivalent to about 0.1 g of etacrynic acid ($C_{13}H_{12}Cl_2O_4$), add 25 mL of 0.1 mol/L hydrochloric acid TS, and extract with three 30-mL portions of dichloromethane. Filter the dichloromethane extracts through a pledget of absorbent cotton into an iodine bottle. Wash the pledget of absorbent cotton with a small amount of dichloromethane, and combine the washing with the extracts. Evaporate this solution on a water bath to dryness in a current of air, to the residue add 20 mL of acetic acid (100), and proceed as directed in the Assay under Etacrynic Acid.

$$\begin{aligned} \text{Each mL of 0.05 mol/L bromine VS} \\ = 15.16 \text{ mg of } C_{13}H_{12}Cl_2O_4 \end{aligned}$$

Containers and storage Containers—Well-closed containers.

Ethambutol Hydrochloride

エタンブトール塩酸塩

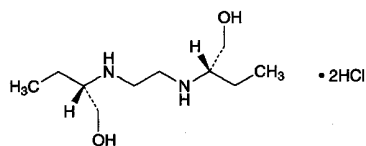

$C_{10}H_{24}N_2O_2 \cdot 2HCl$: 277.23
(2*S*,2'*S*)-2,2'-(Ethane-1,2-diyldiimino)bis(butan-1-ol)
dihydrochloride
[1070-11-7]

Ethambutol Hydrochloride, when dried, contains not less than 98.5% of ethambutol hydrochloride ($C_{10}H_{24}N_2O_2 \cdot 2HCl$).

Description Ethambutol Hydrochloride occurs as white, crystals or crystalline powder. It is odorless, and has a bitter taste.

It is very soluble in water, soluble in methanol and in ethanol (95), and practically insoluble in diethyl ether.

The pH of a solution prepared by dissolving 1.0 g of Ethambutol Hydrochloride in 20 mL of water is between 3.4 and 4.0.

Identification (1) To 10 mL of a solution of Ethambutol Hydrochloride (1 in 100) add 0.5 mL of copper (II) sulfate TS and 2 mL of sodium hydroxide TS: a deep blue color is produced.

(2) Dissolve 0.1 g of Ethambutol Hydrochloride in 40 mL of water, add 20 mL of 2,4,6-trinitrophenol TS, and allow to stand for 1 hour. Collect the precipitate, wash with 50 mL of water, and dry at 105°C for 2 hours: the precipitate melts <2.60> between 193°C and 197°C.

(3) A solution of Ethambutol Hydrochloride (1 in 30) responds to Qualitative Tests <1.09> for chloride.

Optical rotation <2.49> $[\alpha]_D^{20}$: +5.5 – +6.1° (after drying, 5 g, water, 50 mL, 200 mm).

Melting point <2.60> 200 – 204°C

Purity (1) Clarity and color of solution—Dissolve 1.0 g of Ethambutol Hydrochloride in 10 mL of water: the solution is clear and colorless.

(2) Heavy metals <1.07>—Proceed with 2.0 g Ethambutol Hydrochloride according to Method 1, and perform the test. Prepare the control solution with 2.0 mL of Standard Lead Solution (not more than 10 ppm).

(3) Arsenic <1.11>—Prepare the test solution with 1.0 g of Ethambutol Hydrochloride according to Method 1, and perform the test (not more than 2 ppm).

(4) 2-Aminobutanol—Dissolve 5.0 g of Ethambutol Hydrochloride in methanol to make exactly 100 mL, and use this solution as the sample solution. Separately, dissolve 0.05 g of 2-amino-1-butanol in methanol to make exactly 100 mL, and use this solution as the standard solution. Perform the test with these solutions as directed under Thin-layer Chromatography <2.03>. Spot 2 μ L each of the sample solution and standard solution on a plate of silica gel for thin-layer chromatography. Develop the plate with a mixture of ethyl acetate, acetic acid (100), hydrochloric acid and water (11:7:1:1) to a distance of about 10 cm, air-dry the plate, and heat at 105°C for 5 minutes. Cool, spray evenly ninhydrin-L-ascorbic acid TS upon the plate, air-dry the plate, and heat at 105°C for 5 minutes: the spot obtained from the sample

solution, corresponding to that from the standard solution, has no more color than that from the standard solution.

Loss on drying <2.41> Not more than 0.5% (1 g, 105°C, 3 hours).

Residue on ignition <2.44> Not more than 0.1% (1 g).

Assay Weigh accurately about 0.2 g of Ethambutol Hydrochloride, previously dried, dissolve in 20 mL of water, and add 1.8 mL of copper (II) sulfate TS. To the solution add 7 mL of sodium hydroxide TS with shaking, add water to make exactly 50 mL, and centrifuge. Pipet 10 mL of the supernatant liquid, add 10 mL of ammonia-ammonium chloride buffer solution (pH 10.0) and 100 mL of water, and titrate <2.50> with 0.01 mol/L disodium dihydrogen ethylenediamine tetraacetate VS until the color of the solution changes from blue-purple through light red to light yellow (indicator: 0.15 mL of Cu-PAN TS). Perform a blank determination in the same manner, and make any necessary correction.

Each mL of 0.01 mol/L disodium dihydrogen ethylenediamine tetraacetate VS
= 2.772 mg of $C_{10}H_{24}N_2O_2 \cdot 2HCl$

Containers and storage Containers—Tight containers.

Ethanol

Alcohol

エタノール

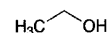

C_2H_6O : 46.07
Ethanol
[64-17-5]

This monograph is harmonized with the European Pharmacopoeia and the U.S. Pharmacopoeia.

The parts of the text that are not harmonized are marked with symbols (◆ ◆).

Information on the harmonization with the European Pharmacopoeia and the U.S. Pharmacopoeia is available on the website of the Pharmaceuticals and Medical Devices Agency.

Ethanol contains not less than 95.1 vol% and not more than 96.9 vol% (by specific gravity) of ethanol (C_2H_6O) at 15°C.

◆**Description** Ethanol is a clear, colorless liquid.

It is miscible with water.

It is flammable and burns with a light blue flame on ignition.

It is volatile.◆

Identification Determine the infrared absorption spectrum of Ethanol as directed in the liquid film method under Infrared Spectrophotometry <2.25>, and compare the spectrum with the Reference Spectrum: both spectra exhibit similar intensities of absorption at the same wave numbers.

Specific gravity <2.56> d_{15}^{15} : 0.80872 – 0.81601

Purity (1) Clarity and color of solution—Ethanol is clear and colorless. To 1.0 mL of Ethanol add water to make 20 mL, and allow to stand for 5 minutes: the resulting liquid is clear.

Control solution: water.

(2) Acidity or alkalinity—To 20 mL of Ethanol add 20 mL of freshly boiled and cooled water and 0.1 mL of a solution prepared by addition of 7.0 mL of ethanol (95) and 2.0 mL of water to 1.0 mL of phenolphthalein TS: no color develops. Add 1.0 mL of 0.01 mol/L sodium hydroxide VS to this solution: a pink color develops.

(3) Volatile impurities—Pipet 500 mL of Ethanol, add 150 μ L of 4-methylpentan-2-ol, and use this solution as the sample solution. Separately, to 100 μ L of anhydrous methanol add Ethanol to make exactly 50 mL. Pipet 5 mL of this solution, add Ethanol to make exactly 50 mL, and use this solution as the standard solution (1). Separately, to 50 μ L each of anhydrous methanol and acetaldehyde add Ethanol to make exactly 50 mL. To 100 μ L of this solution add Ethanol to make exactly 10 mL, and use this solution as the standard solution (2). Separately, to 150 μ L of acetal add Ethanol to make exactly 50 mL. To 100 μ L of this solution add Ethanol to make exactly 10 mL, and use this solution as the standard solution (3). Separately, to 100 μ L of benzene add Ethanol to make exactly 100 mL. To 100 μ L of this solution add Ethanol to make exactly 50 mL, and use this solution as the standard solution (4). Perform the test with exactly 1 μ L each of Ethanol, the sample solution and standard solutions (1), (2), (3) and (4) as directed under Gas Chromatography <2.02> according to the following conditions, and determine the peak areas of acetaldehyde, A_E , benzene, B_E and acetal, C_E obtained with Ethanol, and the peak area of methanol with the standard solution (1), the peak area of acetaldehyde, A_T with the standard solution (2), the peak area of acetal, C_T with the standard solution (3) and the peak area of benzene, B_T with the standard solution (4) by the automatic integration method: the peak area of methanol obtained with Ethanol is not larger than 1/2 times the peak area of methanol with the standard solution (1). When calculate the amounts of the volatile impurities by the following equation, the total amount of acetaldehyde and acetal is not more than 10 vol ppm as acetaldehyde, and the amount of benzene is not more than 2 vol ppm. The total area of the peaks other than the peak mentioned above with the sample solution is not larger than the peak area of 4-methylpentan-2-ol. For this calculation the peak having the area not more than 3% of that of 4-methylpentan-2-ol is excluded.

$$\begin{aligned} \text{Total amount (vol ppm) of acetaldehyde and acetal} \\ = (10 \times A_E)/(A_T - A_E) \\ + (30 \times C_E \times 44.05)/\{(C_T - C_E) \times 118.2\} \end{aligned}$$

$$\text{Amount (vol ppm) of benzene} = 2B_E/(B_T - B_E)$$

If necessary, identify the peak of benzene by using a different stationary liquid phase and suitable chromatographic conditions.

Operating conditions—

Detector: A hydrogen flame-ionization detector.

Column: A fused silica column 0.32 mm in inside diameter and 30 m in length, coated with 6% cyanopropyl phenyl-94% dimethyl silicone polymer for gas chromatography in 1.8 μ m thickness.

Column temperature: Inject at a constant temperature of about 40°C, maintain the temperature for 12 minutes, then raise to 240°C at a rate of 10°C per minute, and maintain at a constant temperature of about 240°C for 10 minutes.

Injection port temperature: 200°C.

Detector temperature: 280°C.

Carrier gas: Helium.

Flow rate: 35 cm per second.

Split ratio: 1:20.

System suitability—

System performance: When the procedure is run with 1 μ L of the standard solution (2) under the above operating conditions, acetaldehyde and methanol are eluted in this order with the resolution between these peaks being not less than 1.5.

(4) Other impurities (absorbance)—Determine the absorption spectrum of Ethanol between 235 nm and 340 nm as directed under Ultraviolet-visible Spectrophotometry <2.24>, in a 5-cm cell using water as a blank: the absorbances at 240 nm, between 250 nm and 260 nm and between 270 nm and 340 nm are not more than 0.40, 0.30, and 0.10, respectively, and the spectrum shows a steadily descending curve with no observable peaks or shoulders.

(5) Residue on evaporation—Evaporate 100 mL of Ethanol, exactly measured, in a tared dish on a water bath, and dry at 105°C for 1 hour: the mass of the residue does not exceed 2.5 mg.

Containers and storage ♦ Containers—Tight containers. ♦ Storage—Without exposure to light.

♦ **Shelf life** In not glass containers: Unless otherwise specified, 24 months after preparation. ♦

Anhydrous Ethanol

Dehydrated Alcohol

無水エタノール

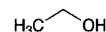

$\text{C}_2\text{H}_6\text{O}$: 46.07

Ethanol

[64-17-5]

This monograph is harmonized with the European Pharmacopoeia and the U.S. Pharmacopoeia.

The parts of the text that are not harmonized are marked with symbols (♦ ♦).

Information on the harmonization with the European Pharmacopoeia and the U.S. Pharmacopoeia is available on the website of the Pharmaceuticals and Medical Devices Agency.

Anhydrous Ethanol contains not less than 99.5 vol% (by specific gravity) of ethanol ($\text{C}_2\text{H}_6\text{O}$) at 15°C.

♦ **Description** Anhydrous Ethanol is a clear, colorless liquid.

It is miscible with water.

It is flammable and burns with a light blue flame on ignition.

It is volatile.

Boiling point: 78 – 79°C ♦

Identification Determine the infrared absorption spectrum of Anhydrous Ethanol as directed in the liquid film method under Infrared Spectrophotometry <2.25>, and compare the spectrum with the Reference Spectrum: both spectra exhibit similar intensities of absorption at the same wave numbers.

Specific gravity <2.56> d_{15}^{15} : 0.79422 – 0.79679

Purity (1) Clarity and color of solution—Anhydrous Ethanol is clear and colorless. To 1.0 mL of Anhydrous Ethanol add water to make 20 mL, and allow to stand for 5 minutes: the resulting liquid is clear.

Control solution: water

(2) Acidity or alkalinity—To 20 mL of Anhydrous Ethanol add 20 mL of freshly boiled and cooled water and 0.1 mL of a solution obtained by addition of 7.0 mL of ethanol (95) and 2.0 mL of water to 1.0 mL of phenolphthalein TS: no color develops. Add 1.0 mL of 0.01 mol/L sodium hydroxide VS to this solution: pink color develops.

(3) Volatile impurities—Pipet 500 mL of Anhydrous Ethanol, add 150 μ L of 4-methylpentan-2-ol, and use this solution as the sample solution. Separately, to 100 μ L of anhydrous methanol add Anhydrous Ethanol to make exactly 50 mL. Pipet 5 mL of this solution, add Anhydrous Ethanol to make exactly 50 mL, and use this solution as the standard solution (1). Separately, to 50 μ L each of anhydrous methanol and acetaldehyde add Anhydrous Ethanol to make exactly 50 mL. To 100 μ L of this solution add Anhydrous Ethanol to make exactly 10 mL, and use this solution as the standard solution (2). Separately, to 150 μ L of acetal add Anhydrous Ethanol to make exactly 50 mL. To 100 μ L of this solution add Anhydrous Ethanol to make exactly 10 mL, and use this solution as the standard solution (3). Separately, to 100 μ L of benzene add Anhydrous Ethanol to make exactly 50 mL, and use this solution as the standard solution (4). Perform the test with exactly 1 μ L each of Anhydrous Ethanol, the sample solution and standard solutions (1), (2), (3) and (4) as directed under Gas Chromatography <2.02> according to the following conditions, and determine the peak areas of acetaldehyde, A_E , benzene, B_E and acetal, C_E obtained with Anhydrous Ethanol, and the peak area of methanol with the standard solution (1), the peak area of acetaldehyde, A_T with the standard solution (2), the peak area of acetal, C_T with the standard solution (3) and the peak area of benzene, B_T with the standard solution (4) by the automatic integration method: the peak area of methanol obtained with Anhydrous Ethanol is not larger than 1/2 times the peak area of methanol with the standard solution (1). When calculate the amounts of the volatile impurities by the following equation, the total amount of acetaldehyde and acetal is not more than 10 vol ppm as acetaldehyde, and the amount of benzene is not more than 2 vol ppm. The total area of the peaks other than the peak mentioned above with the sample solution is not larger than the peak area of 4-methylpentan-2-ol. For this calculation the peak having the area not more than 3% of that of 4-methylpentan-2-ol is excluded.

$$\begin{aligned} & \text{Total amount (vol ppm) of acetaldehyde and acetal} \\ &= (10 \times A_E)/(A_T - A_E) \\ &+ (30 \times C_E \times 44.05)/\{(C_T - C_E) \times 118.2\} \\ & \text{Amount (vol ppm) of benzene} = 2B_E/(B_T - B_E) \end{aligned}$$

If necessary, identify the peak of benzene by using a different stationary liquid phase and suitable chromatographic conditions.

Operating conditions—

Detector: A hydrogen flame-ionization detector.

Column: A fused silica column 0.32 mm in inside diameter and 30 m in length, coated with 6% cyanopropyl phenyl-94% dimethyl silicone polymer for gas chromatography in 1.8 μ m thickness.

Column temperature: Inject at a constant temperature of about 40°C, maintain the temperature for 12 minutes, then raise to 240°C at a rate of 10°C per minute, and maintain at a constant temperature of about 240°C for 10 minutes.

Injection port temperature: 200°C.

Detector temperature: 280°C.

Carrier gas: Helium.

Flow rate: 35 cm per second.

Split ratio: 1:20.

System suitability—

System performance: When the procedure is run with 1 μ L of the standard solution (2) under the above operating conditions, acetaldehyde and methanol are eluted in this order with the resolution between these peaks being not less than 1.5.

(4) Other impurities (absorbance)—Determine the absorption spectrum of Anhydrous Ethanol between 235 nm and 340 nm as directed under Ultraviolet-visible Spectrophotometry <2.24>, in a 5-cm cell using water as a blank: the absorbances at 240 nm, between 250 nm and 260 nm and between 270 nm and 340 nm are not more than 0.40, 0.30, and 0.10, respectively, and the spectrum shows a steadily descending curve with no observable peaks or shoulders.

(5) Residue on evaporation—Evaporate 100 mL of Anhydrous Ethanol, exactly measured, in a tared dish on a water bath, and dry at 105°C for 1 hour: the mass of the residue does not exceed 2.5 mg.

Containers and storage ♦Containers—Tight containers.♦

Storage—Without exposure to light.

♦**Shelf life** In not glass containers: Unless otherwise specified, 24 months after preparation.♦

Ethanol for Disinfection

Alcohol for Disinfection

消毒用エタノール

Ethanol for Disinfection contains not less than 76.9 vol% and not more than 81.4 vol% (by specific gravity) of ethanol (C_2H_6O : 46.07) at 15°C.

Method of preparation

Ethanol	830 mL
Purified Water or Purified Water in Containers	a sufficient quantity
To make 1000 mL	

Prepare by mixing the above ingredients.

Description Ethanol for Disinfection is a colorless, clear liquid.

It is miscible with water.

It burns with a light blue flame on ignition.

It is volatile.

Identification (1) To 1 mL of Ethanol for Disinfection add 2 mL of iodine TS and 1 mL of sodium hydroxide TS, and mix: light yellow precipitates appear.

(2) To 1 mL of Ethanol for Disinfection add 1 mL of acetic acid (100) and 3 drops of sulfuric acid, and heat: the odor of ethyl acetate is produced.

Specific gravity <2.56> d_{15}^{15} : 0.86027 – 0.87264

Purity Proceed as directed in the Purity under Ethanol, with the exception of (4), which is changed as follows.

(4) Other impurities (absorbance)—Perform the test with Ethanol for Disinfection as directed under Ultraviolet-visible Spectrophotometry <2.24>: the absorbances at 240 nm, between 250 nm and 260 nm and between 270 nm and 340 nm are not more than 0.40, 0.30, and 0.10, respectively. The absorption spectrum determined in a 5-cm cell using water as a

blank shows a smooth absorption curve between 235 nm and 340 nm.

Containers and storage Containers—Tight containers.

Storage—Light-resistant.

Ethenzamide

エテンザミド

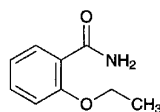

$C_9H_{11}NO_2$: 165.19
2-Ethoxybenzamide
[938-73-8]

Ethenzamide, when dried, contains not less than 98.0% of ethenzamide ($C_9H_{11}NO_2$).

Description Ethenzamide occurs as white, crystals or crystalline powder.

It is soluble in methanol, in ethanol (95), and in acetone, and practically insoluble in water.

It begins to sublime slightly at about 105°C.

Identification (1) Determine the absorption spectrum of a solution of Ethenzamide in methanol (1 in 100,000) as directed under Ultraviolet-visible Spectrophotometry <2.24>, and compare the spectrum with the Reference Spectrum or the spectrum of a solution of Ethenzamide RS prepared in the same manner as the sample solution: both spectra exhibit similar intensities of absorption at the same wavelengths.

(2) Determine the infrared absorption spectrum of Ethenzamide, previously dried, as directed in the potassium bromide disk method under Infrared Spectrophotometry <2.25>, and compare the spectrum with the Reference Spectrum or the spectrum of Ethenzamide RS: both spectra exhibit similar intensities of absorption at the same wave numbers.

Melting point <2.60> 131 – 134°C

Purity (1) Chloride <1.03>—Dissolve 0.5 g of Ethenzamide in 30 mL of acetone, add 6 mL of dilute nitric acid, and dilute with water to make 50 mL. Perform the test using this solution as the test solution. Prepare the control solution as follows: to 0.7 mL of 0.01 mol/L hydrochloric acid VS add 30 mL of acetone and 6 mL of dilute nitric acid, and dilute with water to make 50 mL (not more than 0.050%).

(2) **Sulfate** <1.14>—Dissolve 0.5 g of Ethenzamide in 30 mL of acetone, add 1 mL of dilute hydrochloric acid, and dilute with water to 50 mL. Perform the test using this solution as the test solution. Prepare the control solution as follows: to 0.50 mL of 0.005 mol/L sulfuric acid VS add 30 mL of acetone and 1 mL of dilute hydrochloric acid, and dilute with water to 50 mL (not more than 0.048%).

(3) **Heavy metals** <1.07>—Proceed with 2.0 g of Ethenzamide according to Method 2, and perform the test. Prepare the control solution with 2.0 mL of Standard Lead Solution (not more than 10 ppm).

(4) **Arsenic** <1.11>—To 0.40 g of Ethenzamide add 0.3 g of potassium nitrate and 0.5 g of anhydrous sodium carbonate, mix thoroughly, ignite the mixture gradually, and cool. Dissolve the residue in 10 mL of dilute sulfuric acid, and heat the solution until white fumes begin to evolve. After cooling, add water carefully to make 5 mL, use this solution

as the test solution, and perform the test (not more than 5 ppm).

(5) **Salicylamide**—Dissolve 0.20 g of Ethenzamide in 15 mL of diluted ethanol (95) (2 in 3), and add 2 to 3 drops of dilute iron (III) chloride TS: no purple color develops.

Loss on drying <2.41> Not more than 1.0% (1 g, silica gel, 3 hours).

Residue on ignition <2.44> Not more than 0.1% (1 g).

Assay Weigh accurately about 20 mg each of Ethenzamide and Ethenzamide RS, previously dried, and dissolve each in 70 mL of ethanol (95) by warming, and after cooling, add ethanol (95) to make exactly 100 mL. Pipet 5 mL each of these solutions, add ethanol (95) to make exactly 50 mL, and use these solutions as the sample solution and the standard solution, respectively. Determine the absorbances, A_T and A_S , of the sample solution and standard solution at 290 nm as directed under Ultraviolet-visible Spectrophotometry <2.24>, using ethanol (95) as the blank.

Amount (mg) of ethenzamide ($C_9H_{11}NO_2$) = $M_S \times A_T/A_S$

M_S : Amount (mg) of Ethenzamide RS taken

Containers and storage Containers—Well-closed containers.

Ether

エーテル

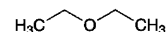

$C_4H_{10}O$: 74.12
Diethyl ether
[60-29-7]

Ether contains not less than 96% and not more than 98% (by specific gravity) of ether ($C_4H_{10}O$).

It contains a small quantity of ethanol and water.

It cannot be used for anesthesia.

Description Ether is a colorless, clear, mobile liquid, having a characteristic odor.

It is miscible with ethanol (95).

It is soluble in water.

It is highly volatile and flammable.

It is slowly oxidized by the action of air and light, with the formation of peroxides.

Its vapor, when mixed with air and ignited, may explode violently.

Boiling point: 35 – 37°C

Specific gravity <2.56> d_{20}^{20} : 0.718 – 0.721

Purity (1) Foreign odor—Place 10 mL of Ether in an evaporating dish, and allow it to evaporate spontaneously to a volume of about 1 mL: no foreign odor is perceptible. Drop this residue onto a piece of clean, odorless filter paper to evaporate the ether: no foreign odor is perceptible.

(2) **Acidity**—Place 10 mL of diluted ethanol (95) (4 in 5) and 0.5 mL of phenolphthalein TS in a 50-mL glass-stoppered flask, and add 0.02 mol/L sodium hydroxide VS dropwise to produce a red color which persists after shaking for 30 seconds. Add 25 mL of Ether, stopper the flask, shake gently, and add 0.40 mL of 0.02 mol/L sodium hydroxide VS with shaking: a red color develops.

(3) **Aldehyde**—Place 10 mL of Ether in a Nessler tube, add 1 mL of potassium hydroxide TS, and allow the mixture

to stand for 2 hours, protecting from light, with occasional shaking: no color is produced in the ether layer and the aqueous layer.

(4) Peroxide—Place 10 mL of Ether in a Nessler tube, add 1 mL of a freshly prepared solution of potassium iodide (1 in 10), shake for 1 minute, then add 1 mL of starch TS, and shake well: no color is produced in the ether layer and in the aqueous layer.

(5) Residue on evaporation—Evaporate 140 mL of Ether, and dry the residue at 105°C for 1 hour: the mass of the residue is not more than 1.0 mg.

Containers and storage Containers—Tight containers.

Storage—Without fill up, light-resistant, remote from fire, and not exceeding 25°C.

Anesthetic Ether

麻醉用エーテル

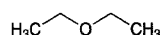

C₄H₁₀O: 74.12
Diethyl ether
[60-29-7]

Anesthetic Ether contains not less than 96% and not more than 98% (by specific gravity) of ether (C₄H₁₀O).

It contains small quantities of ethanol and water. Suitable stabilizers may be added.

It is not to be used for anesthesia if it has been removed from the original container for more than 24 hours.

Description Anesthetic Ether occurs as a colorless, clear, mobile liquid, having a characteristic odor.

It is miscible with ethanol (95).

It is soluble in water.

It is highly volatile and flammable.

It is slowly oxidized by the action of air and light, with the formation of peroxides.

Its vapor, when mixed with air and ignited, may explode violently.

Boiling point: 35 – 37°C

Specific gravity <2.56> d_{20}^{20} : 0.718 – 0.721

Purity (1) Foreign odor—Place 10 mL of Anesthetic Ether in an evaporating dish, and allow it to evaporate spontaneously to a volume of about 1 mL: no foreign odor is perceptible. Drop this residue onto a piece of clean, odorless filter paper to evaporate the ether: no foreign odor is perceptible.

(2) Acidity—Place 10 mL of diluted ethanol (95) (4 in 5) and 0.5 mL of phenolphthalein TS in a 50-mL glass-stoppered flask, and add 0.02 mol/L sodium hydroxide VS dropwise to produce a red color which persists after shaking for 30 seconds. Add 25 mL of Anesthetic Ether, stopper the flask, shake gently, and add 0.40 mL of 0.02 mol/L sodium hydroxide VS with shaking: a red color develops.

(3) Aldehyde—To 100 mL of water in a 200-mL glass-stoppered flask add 10 mL of Anesthetic Ether and 1 mL of a solution of sodium hydrogen sulfite (1 in 1000), stopper tightly, shake vigorously for 10 seconds, and allow the mixture to stand in a cool place for 30 minutes, protected from light. Add 2 mL of starch TS, and add dropwise 0.01 mol/L iodine VS until a pale blue color develops. Shake with about 2 g of sodium hydrogen carbonate to decolorize the solution,

and add 1 mL of diluted 0.01 mol/L iodine VS (9 in 40): a blue color develops. Keep the temperature of the solution below 18°C during the procedure.

(4) Peroxide—Place 10 mL of Anesthetic Ether in a Nessler tube, add 1 mL of a freshly prepared solution of potassium iodide (1 in 10), shake occasionally for 1 hour, protecting from light, then add 1 mL of starch TS, and shake well: no color is produced and in the aqueous layer and in the ether layer.

(5) Residue on evaporation—Evaporate 50 mL of Anesthetic Ether, and dry the residue at 105°C for 1 hour: the mass of the residue is not more than 1.0 mg.

Containers and storage Containers—Tight containers.

Storage—Without fill up, light-resistant, remote from fire, and not exceeding 25°C.

Ethinylestradiol

エチニルエストラジオール

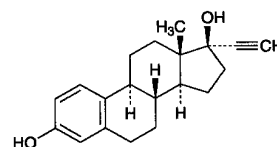

C₂₀H₂₄O₂: 296.40
19-Nor-17 α -pregna-1,3,5(10)-triene-20-yne-3,17-diol
[57-63-6]

Ethinylestradiol, when dried, contains not less than 98.0% of ethinylestradiol (C₂₀H₂₄O₂).

Description Ethinylestradiol occurs as white to pale yellow, crystals or crystalline powder. It is odorless.

It is freely soluble in pyridine and in tetrahydrofuran, soluble in ethanol (95) and in diethyl ether, and practically insoluble in water.

It dissolves in sodium hydroxide TS.

Identification (1) Dissolve 2 mg of Ethinylestradiol in 1 mL of a mixture of sulfuric acid and ethanol (95) (1:1): a purplish red color develops with a yellow-green fluorescence. Add carefully 2 mL of water to this solution: the color of the solution changes to red-purple.

(2) Transfer 0.02 g of Ethinylestradiol to a glass-stoppered test tube, dissolve in 10 mL of a solution of potassium hydroxide (1 in 20), add 0.1 g of benzoyl chloride, and shake. Collect the resulting precipitate, recrystallize from methanol, and dry in a desiccator (in vacuum, phosphorus (V) oxide): the precipitate melts <2.60> between 200°C and 202°C.

Optical rotation <2.49> $[\alpha]_D^{20}$: -26 – -31° (after drying, 0.1 g, pyridine, 25 mL, 100 mm).

Melting point <2.60> 180 – 186°C or 142 – 146°C

Purity Estrone—Dissolve 5 mg of Ethinylestradiol in 0.5 mL of ethanol (95), and add 0.05 g of 1,3-dinitrobenzene. Add 0.5 mL of freshly prepared dilute potassium hydroxide-ethanol TS, allow to stand in a dark place for 1 hour, and add 10 mL of ethanol (95): the solution has no more color than the following control solution.

Control solution: Proceed in the same manner as mentioned above, omitting Ethinylestradiol.

Loss on drying <2.41> Not more than 0.5% (0.5 g, in vacuum, phosphorus (V) oxide, 4 hours).

Residue on ignition <2.44> Not more than 0.1% (0.5 g).

Assay Weigh accurately about 0.2 g of Ethinylestradiol, previously dried, and dissolve in 40 mL of tetrahydrofuran. Add 10 mL of a solution of silver nitrate (1 in 20), and titrate <2.50> with 0.1 mol/L sodium hydroxide VS (potentiometric titration).

Each mL of 0.1 mol/L sodium hydroxide VS
= 29.64 mg of $C_{20}H_{24}O_2$

Containers and storage Containers—Tight containers.
Storage—Light-resistant.

Ethinylestradiol Tablets

エチニルエストラジオール錠

Ethinylestradiol Tablets contain not less than 90.0% and not more than 110.0% of the labeled amount of ethinylestradiol ($C_{20}H_{24}O_2$; 296.40).

Method of preparation Prepare as directed under Tablets, with Ethinylestradiol.

Identification (1) Evaporate to dryness 5 mL of the sample solution obtained in Assay, and add 2 mL of a mixture of sulfuric acid and ethanol (95) (2:1) to the residue: a light red color with a yellow fluorescence develops. To the solution add carefully 4 mL of water: the color of the solution changes to red-purple.

(2) Evaporate to dryness 10 mL of the sample solution obtained in Assay, add 0.2 mL of acetic acid (31) and 2 mL of phosphoric acid to the residue, and heat on a water bath for 5 minutes: a red color with a yellow-green fluorescence develops.

Uniformity of dosage units <6.02> Perform the test according to the following method: it meets the requirement of the Content uniformity test.

Place 1 tablet of Ethinylestradiol Tablets in a separator, add 10 mL of 2nd fluid for disintegration test, and shake until the tablet is disintegrated. Add 10 mL of dilute sulfuric acid and 20 mL of chloroform, shake vigorously for 5 minutes, and filter the chloroform layer into a conical flask through filter paper on which 5 g of anhydrous sodium sulfate is placed. Extract the aqueous layer with two 20-mL portions of chloroform, proceed with the extracts in the same manner as before, and combine the filtrates with the previous one. Evaporate gently the combined filtrate on a water bath with the aid of a current of nitrogen, dissolve the residue in exactly 100 mL of methanol, and centrifuge, if necessary. Pipet x mL of the supernatant liquid, add methanol to make exactly V mL of a solution containing about 40 ng of ethinylestradiol ($C_{20}H_{24}O_2$) per mL, and use this solution as the sample solution. Separately, weigh accurately about 10 mg of Ethinylestradiol RS, previously dried in a desiccator (in vacuum, phosphorus (V) oxide) for 4 hours, dissolve in methanol, dilute to a volume containing about 40 ng of ethinylestradiol ($C_{20}H_{24}O_2$) per mL, and use this solution as the standard solution. Pipet 4 mL each of sulfuric acid-methanol TS into three glass-stoppered test tubes, T, S and B, cool in ice, to each tube add exactly 1 mL each of the sample solution, the standard solution and methanol, shake immediately, and allow to stand in a water bath at 30°C for 40 minutes, then allow to stand in a water bath at 20°C for 5 minutes. Perform the test with these solutions as directed under Fluorometry <2.22>. Determine the fluores-

cence intensities, F_T , F_S and F_B , of these solutions using the fluorophotometer, at about 460 nm of the excitation and at about 493 nm of the fluorescence.

$$\begin{aligned} \text{Amount (mg) of ethinylestradiol (C}_{20}\text{H}_{24}\text{O}_2\text{)} \\ = M_S \times (F_T - F_B)/(F_S - F_B) \times V/2500 \times 1/x \end{aligned}$$

M_S : Amount (mg) of Ethinylestradiol RS taken

Dissolution Being specified separately when the drug is granted approval based on the Law.

Assay (i) Chromatographic tube: Pack a pledget of glass wool in the bottom of a tube 25 mm in inside diameter and 300 mm in length, and place 5 g of anhydrous sodium sulfate on the glass wool.

(ii) Chromatographic column: Place 5 g of siliceous earth for chromatography in a 200-mL beaker, soak well in 4 mL of 1 mol/L hydrochloric acid TS, and mix uniformly. Put the siliceous earth into the chromatographic tube in small portions to make 60 to 80 mm in height in proper hardness with a tamping rod.

(iii) Standard solution: Weigh accurately about 10 mg of Ethinylestradiol RS, previously dried in a desiccator (in vacuum, phosphorus (V) oxide) for 4 hours, and dissolve in chloroform to make exactly 100 mL. Pipet 5 mL of this solution, and add chloroform to make exactly 100 mL.

(iv) Sample: Weigh accurately not less than 20 Ethinylestradiol Tablets, and powder. Weigh accurately a portion of the powder, equivalent to about 0.5 mg of ethinylestradiol ($C_{20}H_{24}O_2$), place in a 50-mL beaker, add 2 mL of water, shake well, add 3 mL of chloroform, and shake well again. Add 4 g of siliceous earth for chromatography, mix well until the contents do not stick to the inner wall of the beaker, and use the substance as the sample.

(v) Procedure: To the chromatographic column add the sample with a funnel, and pack in proper hardness. Mix well the sample sticking to the beaker with 0.5 g of siliceous earth for chromatography, and place in the chromatographic tube. Wipe off the sample solution sticking to the beaker and the tamping rod with glass wool, and place it in the chromatographic tube. Push down the sample, and press lightly on the chromatographic column to make the height of the column 110 mm to 130 mm. Take 70 mL of chloroform, rinse the inner wall of the chromatographic tube with a portion of the chloroform, and transfer the remaining portion to the chromatographic tube. Collect the effluent solution at a flow rate not more than 0.8 mL per minute. After completing the elution, rinse the lower end of the chromatographic tube with a small quantity of chloroform, add chloroform to make exactly 100 mL, and use this solution as the sample solution. Transfer 6 mL each of the sample solution and standard solution to each separator, and add 20 mL each of isooctane. Add exactly 10 mL of a mixture of sulfuric acid and methanol (7:3), shake vigorously for 5 minutes, allow to stand in a dark place for 15 minutes, and centrifuge. Perform the test with the resulting color solutions as directed under Ultraviolet-visible Spectrophotometry <2.24>, using a solution, prepared with 6 mL of chloroform in the same manner, as the blank. Determine the absorbances, A_T and A_S , of the subsequent solutions obtained from the sample solution and standard solution at 540 nm, respectively.

$$\begin{aligned} \text{Amount (mg) of ethinylestradiol (C}_{20}\text{H}_{24}\text{O}_2\text{)} \\ = M_S \times A_T/A_S \times 1/20 \end{aligned}$$

M_S : Amount (mg) of Ethinylestradiol RS taken

Containers and storage Containers—Well-closed containers.

Ethionamide

エチオナミド

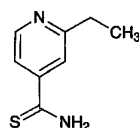

$C_8H_{10}N_2S$: 166.24
2-Ethylpyridine-4-carbothioamide
[536-33-4]

Ethionamide, when dried, contains not less than 98.5% and not more than 101.0% of ethionamide ($C_8H_{10}N_2S$).

Description Ethionamide occurs as yellow, crystals or crystalline powder, having a characteristic odor.

It is soluble in methanol and in acetic acid (100), sparingly soluble in ethanol (99.5) and in acetone, and practically insoluble in water.

Identification (1) Determine the absorption spectrum of a solution of Ethionamide in methanol (3 in 160,000) as directed under Ultraviolet-visible Spectrophotometry <2.24>, and compare the spectrum with the Reference Spectrum: both spectra exhibit similar intensities of absorption at the same wavelengths.

(2) Determine the infrared absorption spectrum of Ethionamide as directed in the potassium bromide disk method under Infrared Spectrophotometry <2.25>, and compare the spectrum with the Reference Spectrum: both spectra exhibit similar intensities of absorption at the same wave numbers.

Melting point <2.60> 161 – 165°C

Purity (1) Acidity—Dissolve 3.0 g of Ethionamide in 30 mL of methanol by warming, add 90 mL of water, allow to stand in ice water for 1 hour, and filter. To 80 mL of the filtrate add 0.8 mL of cresol red TS and 0.20 mL of 0.1 mol/L sodium hydroxide VS: a red color develops.

(2) Heavy metals <1.07>—Proceed with 1.0 g of Ethionamide according to Method 2, and perform the test. Prepare the control solution with 2.0 mL of Standard Lead Solution (not more than 20 ppm).

(3) Arsenic <1.11>—Prepare the test solution with 1.0 g of Ethionamide according to Method 3. Add 10 mL of a solution of magnesium nitrate hexahydrate in ethanol (95) (1 in 50), then add 1.5 mL of hydrogen peroxide (30), and fire to burn (not more than 2 ppm).

(4) Related substances—Conduct this procedure without exposure to light, using light-resistant vessels. Dissolve 0.20 g of Ethionamide in 10 mL of acetone, and use this solution as the sample solution. Pipet 0.5 mL of the sample solution, add acetone to make exactly 100 mL, and use this solution as the standard solution (1). Separately, pipet exactly 0.2 mL of the sample solution, add acetone to make exactly 100 mL, and use this solution as the standard solution (2). Perform the test with these solutions as directed under Thin-layer Chromatography <2.03>. Spot 10 μ L each of the sample solution and standard solutions (1) and (2) on a plate of silica gel with fluorescent indicator for thin-layer chromatography, develop with a mixture of ethyl acetate, hexane and methanol (6:2:1) to a distance of about 15 cm, and air-dry the plate. Examine under ultraviolet light (main wavelength: 254 nm): the spot other than the principal spot obtained from the

sample solution is not more intense than the spot from the standard solution (1), and number of the spot other than the principal spot from the sample solution which is more intense than the spot from the standard solution (2) is not more than one.

Loss on drying <2.41> Not more than 0.5% (1 g, 105°C, 3 hours).

Residue on ignition <2.44> Not more than 0.1% (1 g).

Assay Weigh accurately about 0.3 g of Ethionamide, previously dried, dissolve in 50 mL of acetic acid (100), and titrate <2.50> with 0.1 mol/L perchloric acid VS until the color of the solution changes from orange-red to dark orange-brown (indicator: 2 mL of *p*-naphtholbenzein TS). Perform a blank determination in the same manner, and make any necessary correction.

Each mL of 0.1 mol/L perchloric acid VS
= 16.62 mg of $C_8H_{10}N_2S$

Containers and storage Containers—Well-closed containers.

Ethosuximide

エトスクシミド

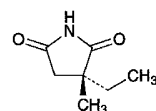

and enantiomer

$C_7H_{11}NO_2$: 141.17
(2*RS*)-2-Ethyl-2-methylsuccinimide
[77-67-8]

Ethosuximide contains not less than 98.5% of ethosuximide ($C_7H_{11}NO_2$), calculated on the anhydrous basis.

Description Ethosuximide occurs as a white, paraffin-like solid or powder. It is odorless or has a slight, characteristic odor.

It is very soluble in methanol, in ethanol (95), in diethyl ether, and in *N,N*-dimethylformamide, and freely soluble in water.

Melting point: about 48°C

Identification (1) To 0.2 g of Ethosuximide add 10 mL of sodium hydroxide TS, and boil: the gas evolved turns a moistened red litmus paper blue.

(2) Dissolve 0.05 g of Ethosuximide in 1 mL of ethanol (95), add 3 drops of a solution of copper (II) acetate monohydrate (1 in 100), warm slightly, and add 1 to 2 drops of sodium hydroxide TS: a purple color is produced.

(3) Determine the absorption spectrum of a solution of Ethosuximide in ethanol (95) (1 in 2000) as directed under Ultraviolet-visible Spectrophotometry <2.24>, and compare the spectrum with the Reference Spectrum: both spectra exhibit similar intensities of absorption at the same wavelengths.

Purity (1) Clarity and color of solution—Dissolve 1.0 g of Ethosuximide in 10 mL of water: the solution is clear and colorless.

(2) Chloride <1.03>—With 1.0 g of Ethosuximide, perform the test. Prepare the control solution with 0.30 mL of 0.01 mol/L hydrochloric acid VS (not more than 0.011%).

(3) Heavy metals <1.07>—Proceed with 1.0 g of Ethosuximide according to Method 1, and perform the test. Prepare the control solution with 2.0 mL of Standard Lead Solution (not more than 20 ppm).

(4) Arsenic <1.11>—Prepare the test solution with 1.0 g of Ethosuximide, according to Method 1, and perform the test (not more than 2 ppm).

(5) Acid anhydride—Dissolve 0.50 g of Ethosuximide in 1 mL of ethanol (95), add 1 mL of hydroxylammonium chloride-iron (III) chloride TS, and allow to stand for 5 minutes. Add 3 mL of water, mix, and allow to stand for 5 minutes: the red to red-purple color of this solution is not more intense than that of the following control solution.

Control solution: Dissolve 70 mg of succinic anhydride in ethanol (95) to make exactly 100 mL. To 1.0 mL of this solution add 1 mL of hydroxylammonium chloride-iron (III) chloride TS, and proceed in the same manner.

(6) Cyanide—Dissolve 1.0 g of Ethosuximide in 10 mL of ethanol (95), and add 3 drops of iron (II) sulfate TS, 1 mL of sodium hydroxide TS and 2 to 3 drops of iron (III) chloride TS. Warm gently, and acidify with dilute sulfuric acid: not a blue precipitate and a blue color are produced within 15 minutes.

Water <2.48> Not more than 0.5% (2 g, volumetric titration, direct titration).

Residue on ignition <2.44> Not more than 0.1% (1 g).

Assay Weigh accurately about 0.2 g of Ethosuximide, dissolve in 20 mL of *N,N*-dimethylformamide, and titrate <2.50> with 0.1 mol/L tetramethylammonium hydroxide VS (potentiometric titration). Perform a blank determination in the same manner, and make any necessary correction.

Each mL of 0.1 mol/L tetramethylammonium hydroxide VS
= 14.12 mg of C₇H₁₁NO₂

Containers and storage Containers—Tight containers.

Ethyl Aminobenzoate

Anesthamine

Benzocaine

アミノ安息香酸エチル

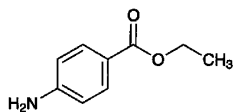

C₉H₁₁NO₂: 165.19
Ethyl 4-aminobenzoate
[94-09-7]

Ethyl Aminobenzoate, when dried, contains not less than 99.0% of ethyl aminobenzoate (C₉H₁₁NO₂).

Description Ethyl Aminobenzoate occurs as white, crystals or crystalline powder. It is odorless. It has a slightly bitter taste, numbing the tongue.

It is freely soluble in ethanol (95) and in diethyl ether, and very slightly soluble in water.

It dissolves in dilute hydrochloric acid.

Identification (1) Dissolve 10 mg of Ethyl Aminobenzoate in 1 mL of dilute hydrochloric acid and 4 mL of water.

This solution responds to Qualitative Tests <1.09> for primary aromatic amines.

(2) Dissolve 0.1 g of Ethyl Aminobenzoate in 5 mL of water with the aid of dilute hydrochloric acid added dropwise, and add iodine TS dropwise: a brown precipitate is produced.

(3) Warm 50 mg of Ethyl Aminobenzoate with 2 drops of acetic acid (31) and 5 drops of sulfuric acid: the odor of ethyl acetate is perceptible.

Melting point <2.60> 89 – 91°C

Purity (1) Acidity—Dissolve 1.0 g of Ethyl Aminobenzoate in 10 mL of neutralized ethanol, and add 10 mL of water, 2 drops of phenolphthalein TS and 0.50 mL of 0.01 mol/L sodium hydroxide VS: a red color is produced.

(2) Chloride—Dissolve 0.20 g of Ethyl Aminobenzoate in 5 mL of ethanol (95), add 2 to 3 drops each of dilute nitric acid and of silver nitrate TS: no change occurs immediately.

(3) Heavy metals <1.07>—Dissolve 2.0 g of Ethyl Aminobenzoate in 20 mL of ethanol (95), add 2 mL of dilute acetic acid and ethanol (95) to make 50 mL, and perform the test using this solution as the test solution. Prepare the control solution as follows: to 2.0 mL of Standard Lead Solution add 2 mL of dilute acetic acid and sufficient ethanol (95) to make 50 mL (not more than 10 ppm).

(4) Readily carbonizable substances <1.15>—Perform the test with 0.5 g of Ethyl Aminobenzoate: the solution has no more color than Matching Fluid A.

Loss on drying <2.41> Not more than 1.0% (1 g, silica gel, 3 hours).

Residue on ignition <2.44> Not more than 0.1% (1 g).

Assay Weigh accurately about 0.25 g of Ethyl Aminobenzoate, previously dried, dissolve in 10 mL of hydrochloric acid and 70 mL of water, add 10 mL of a solution of potassium bromide (3 in 10), and cool to a temperature below 15°C. Then titrate <2.50> with 0.1 mol/L sodium nitrite VS by the potentiometric titration or the amperometric titration.

Each mL of 0.1 mol/L sodium nitrite VS
= 16.52 mg of C₉H₁₁NO₂

Containers and storage Containers—Well-closed containers.

Ethylcellulose

エチルセルロース

[9004-57-3]

This monograph is harmonized with the European Pharmacopoeia and the U. S. Pharmacopoeia.

The corresponding part of the attributes/provisions which are agreed as non-harmonized within the scope of the harmonization is marked with symbols (◆ ◆), and the corresponding parts which are agreed as the JP local requirement other than the scope of the harmonization are marked with symbols (◇ ◇).

Information on the harmonization with the European Pharmacopoeia and the U.S. Pharmacopoeia is available on the website of the Pharmaceuticals and Medical Devices Agency.

Ethylcellulose is a partly *O*-ethylated cellulose.

It contains not less than 44.0% and not more than 51.0% of ethoxy group (-OC₂H₅; 45.06), calculated on

the dried basis.

It may contain a suitable antioxidant.

The viscosity of Ethylcellulose is shown in millipascal second (mPa·s) on the label.

◆**Description** Ethylcellulose occurs as a white to yellowish white, amorphous powder or grains.

It is soluble in dichloromethane.

It forms a slightly white-turbid or white-turbid, viscous liquid upon addition of ethanol (95).

To 1 g of Ethylcellulose add 100 mL of hot water, shake to become turbid, cool to room temperature, and add freshly boiled and cooled water to make 100 mL: the solution is neutral.◆

Identification Spread 2 drops of a solution of Ethylcellulose in dichloromethane (1 in 25) between sodium chloride plates, then remove one of the plates to evaporate the solvent, and determine the infrared absorption spectrum of the plate as directed in the film method under Infrared Spectrophotometry <2.25>, and compare the spectrum with the Reference Spectrum: both spectra exhibit similar intensities of absorption at the same wave numbers.

Viscosity <2.53> Weigh exactly a quantity of Ethylcellulose, equivalent to 5.00 g calculated on the dried basis, add 95 g of a mixture of 80 g of toluene and 20 g of ethanol (95), and shake to dissolve. Perform the test with this solution at 25°C as directed in Method I: not less than 80.0% and not more than 120.0% of the labeled viscosity for a nominal viscosity more than 6 mPa·s, and not less than 75.0% and not more than 140.0% of the labeled viscosity for a nominal viscosity not more than 6 mPa·s.

Purity (1) Acidity or alkalinity—To 0.5 g of Ethylcellulose add 25 mL of freshly boiled and cooled water, shake for 15 minutes, filter through a glass filter (G3), and use the filtrate as the sample solution. To 10 mL of the sample solution add 0.1 mL of dilute phenolphthalein TS and 0.5 mL of 0.01 mol/L sodium hydroxide VS: a light red color develops. To 10 mL of the sample solution add 0.1 mL of methyl red-sodium hydroxide TS and 0.5 mL of 0.01 mol/L hydrochloric acid VS: a red color develops.

(2) Chloride—Disperse 0.250 g of Ethylcellulose in 50 mL of water, and boil with occasional shaking. Allow to cool, and filter. Discard the first 10 mL of the filtrate, to 10 mL of the subsequent filtrate add water to make 15 mL, and use this solution as the sample solution. Separately, to 10 mL of Standard Chloride Solution add 5 mL of water, and use this solution as the control solution. To 15 mL each of the sample solution and control solution add 1 mL of 2 mol/L nitric acid TS, transfer to test tubes containing 1 mL of a solution of silver nitrate (17 in 1000), allow to stand for 5 minutes protecting from light, and compare the opalescence developed in the both solutions against a black background by viewing transversely: the opalescence developed in the sample solution is not more intense than that of the control solution (not more than 0.1%).

◇(3) Heavy metal <1.07>—Proceed with 1.0 g of Ethylcellulose according to Method 2, and perform the test. Prepare the control solution with 4.0 mL of Standard Lead Solution (not more than 40 ppm).◇

(4) Acetaldehyde—Introduce 3.0 g of Ethylcellulose into a 250-mL glass-stoppered conical flask, add 10 mL of water, and stir for 1 hour. Allow to stand for 24 hours, filter, add water to the filtrate to make 100 mL, and use this solution as the sample solution. Separately, dissolve 1.0 g of acetaldehyde for assay in water to make 100 mL. To 5 mL of this solution add water to make 500 mL. To 3 mL of this solution

add water to make 100 mL, and use this solution as the control solution. Transfer 5 mL each of the sample solution and control solution to 25-mL volumetric flasks, add 5 mL of a solution of 3-methyl-2-benzothiazolonehydrazone hydrochloride monohydrate (1 in 2000), and heat in a water bath at 60°C for 5 minutes. Add 2 mL of iron (III) chloride-amidosulfuric acid TS, and warm again at 60°C for 5 minutes. After cooling, add water to make 25 mL, and compare the color of these solutions: the sample solution is not more intensely colored than the control solution (not more than 100 ppm).

Loss on drying <2.41> Not more than 3.0% (1 g, 105°C, 2 hours).

Residue on Ignition <2.44> Not more than 0.5% (1 g).

Assay Weigh accurately about 30 mg of Ethylcellulose, transfer to a 5-mL pressure-tight serum vial, add exactly 60 mg of adipic acid, 2 mL of the internal standard solution and 1 mL of hydroiodic acid, seal the vial immediately with a septum coated with fluororesin and an aluminum cap or any other sealing system providing a sufficient air-tightness, and weigh accurately the vial. Take care not to mix the contents in the vial before heating. Place the vial in an oven or heat in a suitable heater with continuous stirring, maintaining an internal temperature of about 115 ± 2°C for 70 min. Allow to cool, and weigh accurately the vial. If the difference of the mass between before heating and after heating is more than 10 mg, prepare a new sample solution. If the difference of the mass between before heating and after heating is not more than 10 mg, after phase separation, pierce through the septum of the vial with a cooled syringe, and withdraw a sufficient volume of the upper phase as the sample solution. Separately, place exactly 60 mg of adipic acid, 2 mL of the internal standard solution and 1 mL of hydroiodic acid in another serum vial, and seal immediately. Weigh accurately the vial, inject 25 μL of iodoethane for assay through the septum in the vial, and weigh again accurately. Shake thoroughly, after phase separation, pierce through the septum of the vial with a cooled syringe, withdraw a sufficient volume of the upper phase, and use this solution as the standard solution. Perform the test with 1 μL each of the sample solution and standard solution as directed under Gas Chromatography <2.02> according to the following conditions, and calculate the ratios, Q_T and Q_S , of the peak area of iodoethane to that of the internal standard.

$$\begin{aligned} \text{Amount (\% of ethoxy group (C}_2\text{H}_5\text{O)} \\ = M_S/M_T \times Q_T/Q_S \times 28.89 \end{aligned}$$

M_S : Amount (mg) of iodoethane for assay taken

M_T : Amount (mg) of Ethylcellulose taken, calculated on the dried basis

Internal standard solution—A solution of *n*-octane in *o*-xylene (1 in 200).

Operating conditions—

Detector: A hydrogen flame-ionization detector.

Column: A fused silica column 0.53 mm in inside diameter and 30 m in length, coated with dimethylpolysiloxane for gas chromatography in 3 μm thickness.

Column temperature: Maintain the temperature at 50°C for 3 minutes, raise to 100°C at a rate of 10°C per minute, then to 250°C at a rate of 35°C per minute, and maintain at 250°C for 8 minutes.

Injection port temperature: A constant temperature of about 250°C.

Detector temperature: A constant temperature of about 280°C.

Carrier gas: Helium.

Flow rate: 4.2 mL per minute (the retention time of the internal standard is about 10 minutes).

Split ratio: 1:40.

System suitability—

System performance: When the procedure is run with 1 μ L of the standard solution under the above operating conditions, iodoethane and the internal standard are eluted in this order with the relative retention time of iodoethane to the internal standard being about 0.6, and with the resolution between these peaks being not less than 5.0.

System repeatability: When the test is repeated 6 times with 1 μ L of the standard solution under the above operating conditions, the relative standard deviation of the ratio of the peak area of iodoethane to that of the internal standard is not more than 2.0%.

◆**Containers and storage** Containers—Well-closed containers.◆

Ethyl L-Cysteine Hydrochloride

L-エチルシステイン塩酸塩

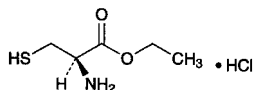

$C_5H_{11}NO_2S \cdot HCl$: 185.67

Ethyl (2*R*)-2-amino-3-sulfanylpropanoate monohydrochloride
[868-59-7]

Ethyl L-Cysteine Hydrochloride, when dried, contains not less than 98.5% of ethyl cysteine hydrochloride ($C_5H_{11}NO_2S \cdot HCl$).

Description Ethyl L-Cysteine Hydrochloride occurs as white, crystals or crystalline powder. It has a characteristic odor, and has a bitter taste at first with a burning aftertaste.

It is very soluble in water, and freely soluble in ethanol (95).

Melting point: about 126°C (with decomposition).

Identification (1) Determine the infrared absorption spectrum of Ethyl L-Cysteine Hydrochloride as directed in the potassium bromide disk method under Infrared Spectrophotometry <2.25>, and compare the spectrum with the Reference Spectrum: both spectra exhibit similar intensities of absorption at the same wave numbers.

(2) A solution of Ethyl L-Cysteine Hydrochloride (1 in 20) responds to Qualitative Tests <1.09> (1) for chloride.

Optical rotation <2.49> $[\alpha]_D^{20}$: $-10.0 - -13.0^\circ$ (after drying, 2.0 g, 1 mol/L hydrochloric acid TS, 25 mL, 100 mm).

Purity (1) Sulfate <1.14>—Perform the test with 0.6 g of Ethyl L-Cysteine Hydrochloride. Prepare the control solution with 0.35 mL of 0.005 mol/L sulfuric acid VS (not more than 0.028%).

(2) Heavy metals <1.07>—Proceed with 1.0 g of Ethyl L-Cysteine Hydrochloride according to Method 1, and perform the test. Prepare the control solution with 1.0 mL of Standard Lead Solution (not more than 10 ppm).

(3) Related substances—Conduct this procedure rapidly. Dissolve 0.05 g each of Ethyl L-Cysteine Hydrochloride and *N*-ethylmaleimide in 5 mL of mobile phase, allow to stand for 30 minutes, and use this solution as the sample solution.

Pipet 3 mL of the sample solution, add the mobile phase to make exactly 200 mL, and use this solution as the standard solution. Perform the test with exactly 2 μ L each of the sample solution and standard solution as directed under Liquid Chromatography <2.01> according to the following conditions. Determine each peak area of these solutions by the automatic integration method: a peak area obtained from the sample solution with the relative retention time to ethyl L-cysteine-*N*-ethylmaleimide complex from the standard solution being about 0.7 is not larger than the peak area of ethyl L-cysteine-*N*-ethylmaleimide complex from the standard solution. Each area of all peaks other than ethyl L-cysteine-*N*-ethylmaleimide complex and *N*-ethylmaleimide from the sample solution is not larger than 1/3 times the peak area of ethyl L-cysteine-*N*-ethylmaleimide complex from the standard solution.

Operating conditions—

Detector: An ultraviolet absorption photometer (wavelength: 250 nm).

Column: A stainless steel column about 6 mm in inside diameter and about 15 cm in length, packed with octadecylsilylanized silica gel for liquid chromatography (5 μ m in particle diameter).

Column temperature: A constant temperature of about 25°C.

Mobile phase: A mixture of 0.02 mol/L potassium dihydrogenphosphate TS and acetonitrile (2:1).

Flow rate: Adjust so that the retention time of ethyl L-cysteine-*N*-ethylmaleimide complex is about 4 minutes.

Selection of column: Dissolve 0.05 g of Ethyl L-Cysteine Hydrochloride, 0.01 g of L-cysteine hydrochloride and 0.05 g of *N*-ethylmaleimide in 25 mL of the mobile phase, and allow to stand for 30 minutes. Proceed with 2 μ L of this solution under the above operating conditions, and calculate the resolution. Use a column giving elution of L-cysteine-*N*-ethylmaleimide complex, ethyl L-cysteine-*N*-ethylmaleimide complex and *N*-ethylmaleimide in this order, complete resolution of each component, and the resolution of the peaks of L-cysteine-*N*-ethylmaleimide complex and ethyl L-cysteine-*N*-ethylmaleimide complex being not less than 3.

Detection sensitivity: Adjust the detection sensitivity so that the peak height of ethyl L-cysteine-*N*-ethylmaleimide complex obtained from 2 μ L of the standard solution is between 10 mm and 20 mm.

Time span of measurement: About 3 times as long as the retention time of ethyl L-cysteine-*N*-ethylmaleimide complex.

Loss on drying <2.41> Not more than 0.5% (1 g, in vacuum, phosphorus oxide (V), 5 hours).

Residue on ignition <2.44> Not more than 0.1% (1 g).

Assay Weigh accurately about 0.25 g of Ethyl L-Cysteine Hydrochloride, previously dried, transfer into a glass-stoppered flask, and dissolve in 10 mL of water previously freshly boiled and cooled to a temperature not exceeding 5°C in a stream of nitrogen. Add exactly 20 mL of 0.05 mol/L iodine VS, previously cooled to a temperature not exceeding 5°C, and allow to stand for 30 seconds, then titrate <2.50> with 0.1 mol/L sodium thiosulfate VS, on cooling below 5°C (indicator: 1 mL of starch TS). Perform a blank determination in the same manner, and make any necessary correction.

Each mL of 0.05 mol/L iodine VS
= 18.57 mg of $C_5H_{11}NO_2S \cdot HCl$

Containers and storage Containers—Tight containers.

Ethylenediamine

エチレンジアミン

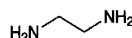

$C_2H_8N_2$: 60.10
Ethane-1,2-diamine
[107-15-3]

Ethylenediamine contains not less than 97.0% of ethylenediamine ($C_2H_8N_2$).

Description Ethylenediamine is a clear, colorless to pale yellow liquid. It has an ammonia-like odor.

It is miscible with water, with ethanol (95) and with diethyl ether.

It has a caustic nature and an irritating property.

It is gradually affected by air.

Specific gravity d_{20}^{20} : about 0.898

Identification (1) A solution of Ethylenediamine (1 in 500) is alkaline.

(2) To 2 mL of copper (II) sulfate TS add 2 drops of ethylenediamine: a blue-purple color develops.

(3) To 0.04 g of Ethylenediamine add 6 drops of benzoyl chloride and 2 mL of a solution of sodium hydroxide (1 in 10), warm for 2 to 3 minutes with occasional shaking, collect the white precipitate formed, and wash with water. Dissolve the precipitate in 8 mL of ethanol (95) by warming, promptly add 8 mL of water, cool, filter the crystals, wash with water, and dry at 105°C for 1 hour: it melts <2.60> between 247°C and 251°C.

Purity (1) Heavy metals <1.07>—Place 1.0 g of Ethylenediamine in a porcelain crucible, evaporate to dryness on a water bath, cover loosely, ignite at a low temperature until charred, proceed according to Method 2, and perform the test. Prepare the control solution with 2.0 mL of Standard Lead Solution (not more than 20 ppm).

(2) Residue on evaporation—Pipet 5 mL of Ethylenediamine, heat on a water bath to dryness, and dry to constant mass at 105°C: the mass of the residue does not exceed 3.0 mg.

Distilling range <2.57> 114 – 119°C, not less than 95 vol%.

Assay Weigh accurately about 0.7 g of Ethylenediamine in a glass-stoppered conical flask, add 50 mL of water, and titrate <2.50> with 1 mol/L hydrochloric acid VS (indicator: 3 drops of bromophenol blue TS).

Each mL of 1 mol/L hydrochloric acid VS
= 30.05 mg of $C_2H_8N_2$

Containers and storage Containers—Tight containers.

Storage—Light-resistant, and almost well-filled.

Ethyl Icosapentate

イコサペント酸エチル

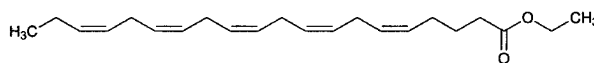

$C_{22}H_{34}O_2$: 330.50
Ethyl (5Z,8Z,11Z,14Z,17Z)-icosa-5,8,11,14,17-pentaenoate
[86227-47-6]

Ethyl Icosapentate contains not less than 96.5% and not more than 101.0% of ethyl icosapentate ($C_{22}H_{34}O_2$).

It may contain a suitable antioxidant.

Description Icosapentate is a colorless or pale yellow, clear liquid. It has a faint, characteristic odor.

It is miscible with ethanol (99.5), with acetic acid (100) and with hexane. It is practically insoluble in water and in ethylene glycol.

Identification (1) To 20 mg of Ethyl Icosapentate add 3 mL of a solution of potassium hydroxide in ethylene glycol (21 in 100), stopper tightly while passing a current of nitrogen, and heat at 180°C for 15 minutes. After cooling, add methanol to make 100 mL. To 4 mL of this solution add methanol to make 100 mL, and use this solution as the sample solution. Determine the absorption spectrum of the sample solution as directed under Ultraviolet-visible Spectrophotometry <2.24>, using a solution, prepared in the same manner as the sample solution with 3 mL of the solution of potassium hydroxide in ethylene glycol (21 in 100), as a control, and compare the spectrum with the Reference Spectrum or the spectrum of a solution of Ethyl Icosapentate RS prepared in the same manner as the sample solution: both spectra exhibit similar intensities of absorption at the same wavelengths.

(2) Determine the infrared absorption spectrum of Ethyl Icosapentate as directed in the liquid film method under Infrared Spectrophotometry <2.25>, and compare the spectrum with the Reference Spectrum or the spectrum of Ethyl Icosapentate RS: both spectra exhibit similar intensities of absorption at the same wave numbers.

Refractive index <2.45> n_D^{20} : 1.481 – 1.491

Specific gravity <2.56> d_{20}^{20} : 0.905 – 0.915

Acid value <1.13> Not more than 0.5.

Saponification value <1.13> 165 – 175

Iodine value <1.13> 365 – 395 Perform the test with 20 mg of Ethyl Icosapentate.

Purity (1) Heavy metals <1.07>—Mix 1.0 g of Ethyl Icosapentate with ethanol (99.5), and add 2 mL of dilute acetic acid and ethanol (99.5) to make 50 mL. Perform the test with this solution as the test solution.

Control solution: To 1.0 mL of Standard Lead Solution add 2 mL of dilute acetic acid and ethanol (99.5) to make 50 mL (not more than 10 ppm).

(2) Arsenic <1.11>—Prepare the test solution with 1.0 g of Ethyl Icosapentate according to Method 3, and perform the test (not more than 2 ppm).

(3) Related substances—To 0.40 g of Ethyl Icosapentate add hexane to make 50 mL, and use this solution as the sample solution. Perform the test with 1.5 μ L of the sample solu-

tion as directed under Gas Chromatography <2.02> according to the following conditions. Determine each peak area by the automatic integration method, and calculate the amounts of these peaks by the area percentage method: the amount of the peak, having the relative retention time of about 0.53 to ethyl icosapentate, is not more than 0.5%, the amount of each peak, having the relative retention time of about 0.80 and 0.93, is not more than 1.0%, the amount of each peak other than the principal peak and the peak mentioned above is not more than 1.0%, and the total amount of these peaks other than the principal peak is not more than 3.5%.

Operating conditions—

Detector, column, column temperature, carrier gas and flow rate: Proceed as directed in the operating conditions in the Assay.

Time span of measurement: About 2.5 times as long as the retention time of ethyl icosapentate, beginning after the solvent peak.

System suitability—

System performance: Proceed as directed in the system suitability in the Assay.

Test for required detectability: To exactly 1 mL of the sample solution add hexane to make exactly 100 mL, and use this solution as the solution for system suitability test. Pipet 1 mL of the solution for system suitability test, and add hexane to make exactly 10 mL. Confirm that the peak area of ethyl icosapentate obtained with 1.5 μ L of this solution is equivalent to 7 to 13% of that with 1.5 μ L of the solution for system suitability test.

System repeatability: When the test is repeated 6 times with 1.5 μ L of the solution for system suitability test under the above operating conditions, the relative standard deviation of the peak area of ethyl icosapentate is not more than 2.0%.

(4) Peroxide—Weigh accurately about 1 g of Ethyl Icosapentate, put in a 200-mL glass-stoppered conical flask, add 25 mL of a mixture of acetic acid (100) and chloroform (3:2), and dissolve by gentle shaking. Add 1 mL of saturated potassium iodide solution TS, immediately stopper tightly, shake gently, and allow to stand in a dark place for 10 minutes. Then add 30 mL of water, shake vigorously for 5 to 10 seconds, and titrate <2.50> with 0.01 mol/L sodium thiosulfate VS until the blue color of the solution disappears after addition of 1 mL of starch TS. Calculate the amount of peroxide by the following equation: not more than 2 mEq/kg.

$$\text{Amount (mEq/kg) of peroxide} = V/M \times 10$$

V: Volume (mL) of 0.01 mol/L sodium thiosulfate VS consumed

M: Amount (g) of Ethyl Icosapentate taken

Residue on ignition <2.44> Not more than 0.1% (1 g).

Assay Weigh accurately about 0.4 g of Ethyl Icosapentate, and add hexane to make exactly 50 mL. Pipet 2 mL of this solution, add exactly 2 mL of the internal standard solution, and use this solution as the sample solution. Separately, weigh accurately about 80 mg of Ethyl Icosapentate RS, and add hexane to make exactly 10 mL. Pipet 2 mL of this solution, add exactly 2 mL of the internal standard solution, and use this solution as the standard solution. Perform the test with 3 μ L each of the sample solution and standard solution as directed under Gas Chromatography <2.02> according to the following conditions, and calculate the ratios, Q_T and Q_S , of the peak area of ethyl icosapentate to that of the internal standard.

$$\begin{aligned} \text{Amount (mg) of ethyl icosapentate (C}_{22}\text{H}_{34}\text{O}_2) \\ = M_S \times Q_T/Q_S \times 5 \end{aligned}$$

M_S : Amount (mg) of Ethyl Icosapentate RS taken

Internal standard solution—A solution of methyl docosanate in hexane (1 in 125).

Operating conditions—

Detector: A hydrogen flame-ionization detector.

Column: A glass column in 4 mm inside diameter and 1.8 m in length, packed with siliceous earth for gas chromatography (175 to 246 μ m in particle diameter), coated with diethylene glycol succinate polyester for gas chromatography in the ratio of 25%.

Column temperature: A constant temperature of about 190°C.

Carrier gas: Nitrogen.

Flow rate: Adjust so that the retention time of ethyl icosapentate is about 30 minutes.

System suitability—

System performance: When the procedure is run with 3 μ L of the standard solution under the above operating conditions, the internal standard and ethyl icosapentate are eluted in this order with the resolution between these peaks being not less than 3.

System repeatability: When the test is repeated 6 times with 3 μ L of the standard solution under the above operating conditions, the relative standard deviation of the ratio of the peak area of ethyl icosapentate to that of the internal standard is not more than 1.0%.

Containers and storage Containers—Tight containers.

Storage—Being fully filled, or replacing the air with Nitrogen.

Ethyl Icosapentate Capsules

イコサペント酸エチルカプセル

Ethyl Icosapentate Capsules contain not less than 95.0% and not more than 105.0% of the labeled amount of ethyl icosapentate (C₂₂H₃₄O₂: 330.50).

Method of preparation Prepare as directed under Capsules, with Ethyl Icosapentate.

Identification Take out the content of Ethyl Icosapentate Capsules, to a quantity of the contents, equivalent to 20 mg of Ethyl Icosapentate, add 3 mL of a solution of potassium hydroxide in ethylene glycol (21 in 100), stopper the vessel tightly while passing a current of nitrogen, and heat at 180°C for 15 minutes. After cooling, add methanol to make 100 mL. To 1 mL of this solution add methanol to make 25 mL, and determine the absorption spectrum of this solution as directed under Ultraviolet-visible Spectrophotometry <2.24> using a solution, obtained by proceeding as above with 3 mL of a solution of potassium hydroxide in ethylene glycol (21 in 100), as a blank: it exhibits maxima between 298 nm and 302 nm, between 311 nm and 315 nm, between 325 nm and 329 nm, and between 343 nm and 347 nm.

Purity Peroxide—Take out the content of Ethyl Icosapentate Capsules. Weigh accurately about 1 g of the content, dissolve in 25 mL of a mixture of acetic acid (100) and isoocane (3:2), replace the air of the inside gently with Nitrogen, then add 1 mL of saturated potassium iodide TS under a current of Nitrogen, stopper immediately and shake gently, and allow to stand in a dark place for 10 minutes. Then, add

30 mL of water, shake vigorously, and titrate <2.50> with 0.01 mol/L sodium thiosulfate VS (indicator: 1 mL of starch TS). Perform a blank determination in the same manner, and make any necessary correction. The amount of peroxide calculated by the following formula is not more than 20 mEq/kg.

$$\text{Amount (mEq/kg) of peroxide} = V/M \times 10$$

V: Amount (mL) of 0.01 mol/L sodium thiosulfate VS consumed

M: Amount (g) of Ethyl Icosapentate Capsules taken

Uniformity of dosage units <6.02> It meets the requirement of the Mass variation test.

Disintegration <6.09> Perform the test using the disk: it meets the requirement. However, for the preparations in single-dose packages, carry out the test for 10 minutes.

Assay Weigh accurately the mass of an amount of not less than 20 Ethyl Icosapentate Capsules, then open the capsules and take out the contents. Wash the empty capsules with a little amount of hexane, volatilize the hexane by allowing them to stand at the room temperature, and weigh the mass of the total empty capsules accurately. Weigh accurately a portion of the content, equivalent to about 0.4 g of ethyl icosapentate (C₂₂H₃₄O₂), add exactly 40 mL of the internal standard solution, then add hexane to make 200 mL, and use this solution as the sample solution. For the preparations in single-dose packages, weigh accurately the mass of the total capsules of not less than 20 packages, and mix them well. Weigh accurately a portion of the capsules, equivalent to about 0.4 g of ethyl icosapentate (C₂₂H₃₄O₂), add 15 mL of hexane, then extract the content by opening the capsules. Separate the hexane extract from the residual solids, wash the residues with three 10-mL portions of hexane, combine the washings and the hexane extract, add exactly 40 mL of the internal standard solution, then add hexane to make 200 mL, and use this solution as the sample solution. Separately, weigh accurately about 50 mg of Ethyl Icosapentate RS, add exactly 5 mL of the internal standard solution, then add hexane to make 25 mL, and use this solution as the standard solution. Perform the test with 4 μL each of the sample solution and standard solution as directed under Gas Chromatography <2.02> according to the following conditions, and calculate the ratios, *Q_T* and *Q_S*, of the peak area of ethyl icosapentate to that of the internal standard.

$$\begin{aligned} \text{Amount (mg) of ethyl icosapentate (C}_{22}\text{H}_{34}\text{O}_2) \\ = M_S \times Q_T / Q_S \times 8 \end{aligned}$$

M_S: Amount (mg) of Ethyl Icosapentate RS taken

Internal standard solution—A solution of methyl docosanate in hexane (1 in 200).

Operating conditions—

Proceed as directed in the operating conditions in the Assay under Ethyl Icosapentate.

System suitability—

System performance: When the procedure is run with 4 μL of the standard solution under the above operating conditions, the internal standard and ethyl icosapentate are eluted in this order with the resolution between these peaks being not less than 3.

System repeatability: When the test is repeated 6 times with 4 μL of the standard solution under the above operating conditions, the relative standard deviation of the ratio of the peak area of ethyl icosapentate to that of the internal standard is not more than 1.0%.

Containers and storage Containers—Tight containers.

Ethyl Loflazepate

ロフラゼパ酸エチル

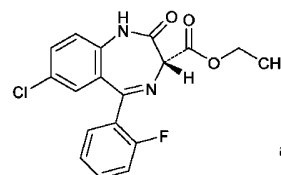

and enantiomer

C₁₈H₁₄ClFN₂O₃: 360.77

Ethyl (3*RS*)-7-chloro-5-(2-fluorophenyl)-2-oxo-2,3-dihydro-1*H*-1,4-benzodiazepine-3-carboxylate
[29177-84-2]

Ethyl Loflazepate, when dried, contains not less than 98.5% and not more than 102.0% of ethyl loflazepate (C₁₈H₁₄ClFN₂O₃).

Description Ethyl Loflazepate occurs as a white crystalline powder.

It is freely soluble in dimethylsulfoxide, sparingly soluble in acetonitrile, slightly soluble in ethanol (99.5), and practically insoluble in water.

A solution of Ethyl Loflazepate in dimethylsulfoxide (1 in 50) shows no optical rotation.

Melting point: about 199°C (with decomposition).

Identification (1) Determine the absorption spectrum of a solution of Ethyl Loflazepate in acetonitrile (1 in 100,000) as directed under Ultraviolet-visible Spectrophotometry <2.24>, and compare the spectrum with the Reference Spectrum or the spectrum of a solution of Ethyl Loflazepate RS prepared in the same manner as the sample solution: both spectra exhibit similar intensities of absorption at the same wavelengths.

(2) Determine the infrared absorption spectrum of Ethyl Loflazepate, previously dried, as directed in the potassium bromide disk method under Infrared Spectrophotometry <2.25>, and compare the spectrum with the Reference Spectrum or the spectrum of dried Ethyl Loflazepate RS: both spectra exhibit similar intensities of absorption at the same wave numbers.

Purity (1) Soluble halides—To 1.0 g of Ethyl Loflazepate add 50 mL of water, allow to stand for 1 hour with occasional shaking, and filter. Discard the first 10 mL of the filtrate, transfer 25 mL of the subsequent filtrate to a Nessler tube, add 6 mL of dilute nitric acid and water to make 50 mL, and use this solution as the test solution. Proceed as directed under Chloride Limit Test <1.03>. Prepare the control solution as follows: to 0.20 mL of 0.01 mol/L hydrochloric acid VS add 6 mL of dilute nitric acid and water to make 50 mL.

(2) Heavy metals <1.07>—Proceed with 1.0 g of Ethyl Loflazepate according to Method 2, and perform the test. Prepare the control solution with 2.0 mL of Standard Lead Solution (not more than 20 ppm).

(3) Arsenic <1.11>—Prepare the test solution with 1.0 g of Ethyl Loflazepate according to Method 3, and perform the test (not more than 2 ppm).

(4) Related substances—Dissolve 20 mg of Ethyl Loflazepate in 20 mL of the mobile phase, and use this solution as the sample solution. Pipet 1 mL of the sample solu-

tion, add the mobile phase to make exactly 100 mL, and use this solution as the standard solution. Perform the test with exactly 5 μ L each of the sample solution and standard solution as directed under Liquid Chromatography <2.01> according to the following conditions, and determine each peak area by the automatic integration method: the peak area of the related substance A, having the relative retention time of about 1.15 to ethyl loflazepate, obtained from the sample solution is not larger than 1/5 times the peak area of ethyl loflazepate from the standard solution, the peak area of the related substance B, having the relative retention time of about 1.38, from the sample solution is not larger than 7/10 times the peak area of ethyl loflazepate from the standard solution, and the area of the peak other than ethyl loflazepate and the peaks mentioned above from the sample solution is not larger than 1/10 times the peak area of ethyl loflazepate from the standard solution. Furthermore, the total area of the peaks other than ethyl loflazepate from the sample solution is not larger than the peak area of ethyl loflazepate from the standard solution.

Operating conditions—

Detector: An ultraviolet absorption photometer (wavelength: 254 nm).

Column: A stainless steel column 4.6 mm in inside diameter and 15 cm in length, packed with octadecylsilanized silica gel for liquid chromatography (5 μ m in particle diameter).

Column temperature: A constant temperature of about 25°C.

Mobile phase: Dissolve 3.9 g of sodium dihydrogen phosphate dihydrate in water to make 1000 mL, and adjust to pH 6.0 with a solution prepared by dissolving 9.0 g of disodium hydrogen phosphate dodecahydrate in water to make 1000 mL. To 500 mL of this solution add 500 mL of acetonitrile for liquid chromatography.

Flow rate: Adjust so that the retention time of ethyl loflazepate is about 10 minutes.

Time span of measurement: About 3 times as long as the retention time of ethyl loflazepate.

System suitability—

Test for required detectability: Pipet 1 mL of the standard solution, and add the mobile phase to make exactly 20 mL. Confirm that the peak area of ethyl loflazepate obtained with 5 μ L of this solution is equivalent to 4 to 6% of that with 5 μ L of the standard solution.

System performance: When the procedure is run with 5 μ L of the standard solution under the above operating conditions, the number of theoretical plates and the symmetry factor of the peak of ethyl loflazepate are not less than 2500 and not more than 2.0, respectively.

System repeatability: When the test is repeated 6 times with 5 μ L of the standard solution under the above operating conditions, the relative standard deviation of the peak area of ethyl loflazepate is not more than 2.0%.

Loss on drying <2.41> Not more than 0.2% (0.2 g, 105°C, 3 hours).

Residue on ignition <2.44> Not more than 0.1% (0.5 g, platinum crucible).

Assay Weigh accurately about 10 mg each of Ethyl Loflazepate and Ethyl Loflazepate RS, both previously dried, add the internal standard solution to dissolve to make exactly 100 mL, and use these solutions as the sample solution and the standard solution, respectively. Perform the test with 10 μ L each of the sample solution and standard solution as directed under Liquid Chromatography <2.01> according to the following conditions, and calculate the ratios, Q_T and

Q_S , of the peak area of ethyl loflazepate to that of the internal standard.

$$\begin{aligned} \text{Amount (mg) of ethyl loflazepate (C}_{18}\text{H}_{14}\text{ClFN}_2\text{O}_3) \\ = M_S \times Q_T / Q_S \end{aligned}$$

M_S : Amount (mg) of Ethyl Loflazepate RS taken

Internal standard solution—A solution of methyl parahydroxybenzoate in acetonitrile for liquid chromatography (1 in 3000).

Operating conditions—

Detector: An ultraviolet absorption photometer (wavelength: 229 nm).

Column: A stainless steel column 4.0 mm in inside diameter and 25 cm in length, packed with octadecylsilanized silica gel for liquid chromatography (7 μ m in particle diameter).

Column temperature: A constant temperature of about 25°C.

Mobile phase: A mixture of water, acetonitrile for liquid chromatography and ethanol (95) (2:1:1).

Flow rate: Adjust so that the retention time of ethyl loflazepate is about 13 minutes.

System suitability—

System performance: When the procedure is run with 10 μ L of the standard solution under the above operating conditions, the internal standard and ethyl loflazepate are eluted in this order with the resolution between these peaks being not less than 6.

System repeatability: When the test is repeated 6 times with 10 μ L of the standard solution under the above operating conditions, the relative standard deviation of the ratio of the peak area of ethyl loflazepate to that of the internal standard is not more than 1.0%.

Containers and storage Containers—Tight containers.

Others

Related substance A:

Ethyl 7-chloro-2-oxo-5-phenyl-2,3-dihydro-1H-1,4-benzodiazepine-3-carboxylate

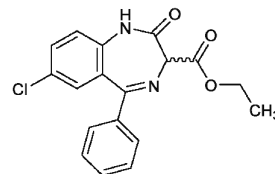

Related substance B:

Propyl 7-chloro-5-(2-fluorophenyl)-2-oxo-2,3-dihydro-1H-1,4-benzodiazepine-3-carboxylate

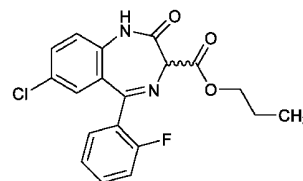

Ethyl Loflazepate Tablets

ロフラゼパ酸エチル錠

Ethyl Loflazepate Tablets contain not less than 93.0% and not more than 107.0% of the labeled amount of ethyl loflazepate ($C_{18}H_{14}ClFN_2O_3$; 360.77).

Method of preparation Prepare as directed under Tablets, with Ethyl Loflazepate.

Identification To a quantity of powdered Ethyl Loflazepate Tablets, equivalent to 1 mg of Ethyl Loflazepate, add 10 mL of acetonitrile, shake for 15 minutes, and centrifuge. To 1 mL of the supernatant liquid add acetonitrile to make 10 mL. Determine the absorption spectrum of this solution as directed under Ultraviolet-visible Spectrophotometry <2.24>: it exhibits a maximum between 227 nm and 231 nm.

Uniformity of dosage units <6.02> Perform the test according to the following method: it meets the requirement of the Content uniformity test.

To 1 tablet of Ethyl Loflazepate Tablets add exactly 0.5 mL of water, sonicate to disintegrate the tablet, add exactly 10 mL of the internal standard solution, shake for 20 minutes, and centrifuge. Pipet V mL of the supernatant liquid, add water so that each mL contains 48 μ L of water, add the internal standard solution to make exactly V' mL so that each mL contains about 95 μ g of ethyl loflazepate ($C_{18}H_{14}ClFN_2O_3$), and use this solution as the sample solution. Then, proceed as directed in the Assay.

$$\begin{aligned} &\text{Amount (mg) of ethyl loflazepate } (C_{18}H_{14}ClFN_2O_3) \\ &= M_S \times Q_T/Q_S \times V'/V \times 1/10 \end{aligned}$$

M_S : Amount (mg) of Ethyl Loflazepate RS taken

Internal standard solution—A solution of methyl parahydroxybenzoate in acetonitrile for liquid chromatography (1 in 3000).

Dissolution <6.10> When the test is performed at 50 revolutions per minute according to the Paddle method, using 900 mL of water as the dissolution medium, the dissolution rate in 30 minutes of Ethyl Loflazepate Tablets is not less than 80%.

Start the test with 1 tablet of Ethyl Loflazepate Tablets, withdraw not less than 20 mL of the medium at the specified minute after starting the test, and filter through a membrane filter with a pore size not exceeding 0.45 μ m. Discard not less than 10 mL of the first filtrate, pipet V mL of the subsequent filtrate, add water to make exactly V' mL so that each mL contains about 1.1 μ g of ethyl loflazepate ($C_{18}H_{14}ClFN_2O_3$), and use this solution as the sample solution. Separately, weigh accurately about 22 mg of Ethyl Loflazepate RS, previously dried at 105°C for 3 hours, and dissolve in ethanol (95) to make exactly 100 mL. Pipet 1 mL of this solution, add water to make exactly 200 mL, and use this solution as the standard solution. Perform the test with exactly 10 μ L each of the sample solution and standard solution as directed under Liquid Chromatography <2.01> according to the following conditions, and determine the peak areas, A_T and A_S , of ethyl loflazepate in each solution.

$$\begin{aligned} &\text{Dissolution rate (\%)} \text{ with respect to the labeled amount} \\ &\text{of ethyl loflazepate } (C_{18}H_{14}ClFN_2O_3) \\ &= M_S \times A_T/A_S \times V'/V \times 1/C \times 9/2 \end{aligned}$$

M_S : Amount (mg) of Ethyl Loflazepate RS taken

C : Labeled amount (mg) of ethyl loflazepate

($C_{18}H_{14}ClFN_2O_3$) in 1 tablet

Operating conditions—

Detector: An ultraviolet absorption photometer (wavelength: 230 nm).

Column: A stainless steel column 4.0 mm in inside diameter and 15 cm in length, packed with octadecylsilanized silica gel for liquid chromatography (5 μ m in particle diameter).

Column temperature: A constant temperature of about 25°C.

Mobile phase: A mixture of water, acetonitrile and ethanol (99.5) (2:1:1).

Flow rate: Adjust so that the retention time of ethyl loflazepate is about 7 minutes.

System suitability—

System performance: When the procedure is run with 10 μ L of the standard solution under the above operating conditions, the number of theoretical plates and the symmetry factor of the peak of ethyl loflazepate are not less than 1500 and not more than 1.5, respectively.

System repeatability: When the test is repeated 6 times with 10 μ L of the standard solution under the above operating conditions, the relative standard deviation of the peak area of ethyl loflazepate is not more than 3.0%.

Assay Weigh accurately the mass of not less than 20 tablets of Ethyl Loflazepate Tablets, and powder. Weigh accurately a portion of the powder, equivalent to about 1 mg of ethyl loflazepate ($C_{18}H_{14}ClFN_2O_3$), add 0.5 mL of water, and sonicate. Add exactly 10 mL of the internal standard, shake, centrifuge, and use the supernatant liquid as the sample solution. Separately, weigh accurately about 10 mg of Ethyl Loflazepate RS, previously dried at 105°C for 3 hours, and add the internal standard solution to make exactly 100 mL. To 10 mL of this solution add 0.5 mL of water, and use this solution as the standard solution. Perform the test with exactly 10 μ L each of the sample solution and standard solution as directed under Liquid Chromatography <2.01> according to the following conditions, and calculate the ratios, Q_T and Q_S , of the peak area of ethyl loflazepate to that of the internal standard.

$$\begin{aligned} &\text{Amount (mg) of ethyl loflazepate } (C_{18}H_{14}ClFN_2O_3) \\ &= M_S \times Q_T/Q_S \times 1/10 \end{aligned}$$

M_S : Amount (mg) of Ethyl Loflazepate RS taken

Internal standard solution—A solution of methyl parahydroxybenzoate in acetonitrile for liquid chromatography (1 in 3000).

Operating conditions—

Detector: An ultraviolet absorption photometer (wavelength: 229 nm).

Column: A stainless steel column 4.6 mm in inside diameter and 25 cm in length, packed with octadecylsilanized silica gel for liquid chromatography (5 μ m in particle diameter).

Column temperature: A constant temperature of about 25°C.

Mobile phase: A mixture of water, acetonitrile for liquid chromatography and ethanol (95) (2:1:1).

Flow rate: Adjust so that the retention time of ethyl loflazepate is about 13 minutes.

System suitability—

System performance: When the procedure is run with 10 μ L of the standard solution under the above operating conditions, the internal standard and ethyl loflazepate are eluted in this order with the resolution between these peaks being not less than 6.

System repeatability: When the test is repeated 6 times

with 10 μL of the standard solution under the above operating conditions, the relative standard deviation of the ratio of the peak area of ethyl loflazepate to that of the internal standard is not more than 1.0%.

Containers and storage Containers—Well-closed containers.

Ethylmorphine Hydrochloride Hydrate

エチルモルヒネ塩酸塩水和物

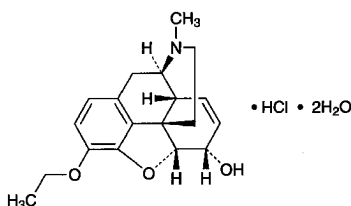

$\text{C}_{19}\text{H}_{23}\text{NO}_3 \cdot \text{HCl} \cdot 2\text{H}_2\text{O}$: 385.88
(5*R*,6*S*)-4,5-Epoxy-3-ethoxy-17-methyl-7,8-didehydromorphinan-6-ol monohydrochloride dihydrate [I25-30-4, anhydride]

Ethylmorphine Hydrochloride Hydrate contains not less than 98.0% of ethylmorphine hydrochloride ($\text{C}_{19}\text{H}_{23}\text{NO}_3 \cdot \text{HCl}$: 349.85), calculated on the anhydrous basis.

Description Ethylmorphine Hydrochloride Hydrate occurs as white to pale yellow, crystals or crystalline powder.

It is very soluble in methanol and in acetic acid (100), freely soluble in water, soluble in ethanol (95), sparingly soluble in acetic anhydride, and practically insoluble in diethyl ether.

It is affected by light.

Melting point: about 123°C (with decomposition).

Identification (1) Determine the absorption spectrum of a solution of Ethylmorphine Hydrochloride Hydrate (1 in 10,000) as directed under Ultraviolet-visible Spectrophotometry <2.24>, and compare the spectrum with the Reference Spectrum: both spectra exhibit similar intensities of absorption at the same wavelengths.

(2) Determine the infrared absorption spectrum of Ethylmorphine Hydrochloride Hydrate as directed in the potassium bromide disk method under Infrared Spectrophotometry <2.25>, and compare the spectrum with the Reference Spectrum: both spectra exhibit similar intensities of absorption at the same wave numbers.

(3) A solution of Ethylmorphine Hydrochloride Hydrate (1 in 50) responds to Qualitative Tests <1.09> (2) for chloride.

Optical rotation <2.49> $[\alpha]_D^{20}$: -103 – -106° (0.4 g calculated on the anhydrous basis, water, 20 mL, 100 mm).

pH <2.54> Dissolve 0.10 g of Ethylmorphine Hydrochloride Hydrate in 10 mL of water: the pH of this solution is between 4.0 and 6.0.

Purity Related substances—Dissolve 0.20 g of Ethylmorphine Hydrochloride Hydrate in 10 mL of diluted ethanol (1 in 2), and use this solution as the sample solution. Pipet 0.5 mL of the sample solution, add diluted ethanol (1 in 2) to make exactly 100 mL, and use this solution as the standard solution. Perform the test with these solutions as directed under Thin-layer Chromatography <2.03>. Spot 10 μL each

of the sample solution and standard solution on a plate of silica gel with fluorescent indicator for thin-layer chromatography. Develop the plate with a mixture of ethanol (99.5), toluene, acetone and ammonia solution (28) (14:14:7:1) to a distance of about 10 cm, and air-dry the plate. Examine under ultraviolet light (main wavelength: 254 nm): the spots other than the principal spot obtained from the sample solution are not more intense than the spot from the standard solution.

Water <2.48> 8.0 – 10.0% (0.25 g, volumetric titration, direct titration).

Residue on ignition <2.44> Not more than 0.1% (0.5 g).

Assay Weigh accurately about 0.5 g of Ethylmorphine Hydrochloride Hydrate, and dissolve in 50 mL of a mixture of acetic anhydride and acetic acid (100) (7:3), and titrate <2.50> with 0.1 mol/L perchloric acid VS (potentiometric titration). Perform a blank determination in the same manner, and make any necessary correction.

Each mL of 0.1 mol/L perchloric acid VS
= 34.99 mg of $\text{C}_{19}\text{H}_{23}\text{NO}_3 \cdot \text{HCl}$

Containers and storage Containers—Tight containers.
Storage—Light-resistant.

Ethyl Parahydroxybenzoate

パラオキシ安息香酸エチル

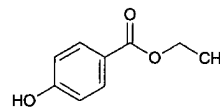

$\text{C}_9\text{H}_{10}\text{O}_3$: 166.17
Ethyl 4-hydroxybenzoate
[I20-47-8]

This monograph is harmonized with the European Pharmacopoeia and the U.S. Pharmacopoeia.

The parts of the text that are not harmonized are marked with symbols (◆ ◆).

Information on the harmonization with the European Pharmacopoeia and the U.S. Pharmacopoeia is available on the website of the Pharmaceuticals and Medical Devices Agency.

Ethyl Parahydroxybenzoate contains not less than 98.0% and not more than 102.0% of ethyl parahydroxybenzoate ($\text{C}_9\text{H}_{10}\text{O}_3$).

◆**Description** Ethyl Parahydroxybenzoate occurs as colorless crystals or a white crystalline powder.

It is freely soluble in methanol, in ethanol (95) and in acetone, and very slightly soluble in water.◆

Identification Determine the infrared absorption spectrum of Ethyl Parahydroxybenzoate as directed in the potassium bromide disk method under Infrared Spectrophotometry <2.25>, and compare the spectrum with the Reference Spectrum or the spectrum of Ethyl Parahydroxybenzoate RS: both spectra exhibit similar intensities of absorption at the same wave numbers.

Melting point <2.60> 115 – 118°C

Purity (1) Clarity and color of solution—Dissolve 1.0 g of Ethyl Parahydroxybenzoate in ethanol (95) to make 10 mL: the solution is clear and not more intensely colored than

the following control solution.

Control solution: To 5.0 mL of Cobalt (II) Chloride CS, 12.0 mL of Iron (III) Chloride CS and 2.0 mL of Copper (II) Sulfate CS add diluted dilute hydrochloric acid (1 in 10) to make 1000 mL.

(2) Acidity—To 2 mL of the solution of Ethyl Parahydroxybenzoate obtained in (1) add 3 mL of ethanol (95), add 5 mL of freshly boiled and cooled water and 0.1 mL of bromocresol green-sodium hydroxide-ethanol TS, then add 0.1 mol/L sodium hydroxide VS until the solution shows a blue color: the volume of 0.1 mol/L sodium hydroxide VS used does not exceed 0.1 mL.

◆(3) Heavy metals <1.07>—Dissolve 1.0 g of Ethyl Parahydroxybenzoate in 25 mL of acetone, add 2 mL of dilute acetic acid and water to make 50 mL, and perform the test using this solution as the test solution. Prepare the control solution as follows: to 2.0 mL of Standard Lead Solution add 25 mL of acetone, 2 mL of dilute acetic acid, and water to make 50 mL (not more than 20 ppm).◆

(4) Related substances—Dissolve 50.0 mg of Ethyl Parahydroxybenzoate in 2.5 mL of methanol, and add the mobile phase to make exactly 50 mL. Pipet 10 mL of this solution, add the mobile phase to make exactly 100 mL, and use this solution as the sample solution. Pipet 1 mL of the sample solution, and add the mobile phase to make exactly 20 mL. Pipet 1 mL of this solution, add the mobile phase to make exactly 10 mL, and use this solution as the standard solution. Perform the test with exactly 10 μ L each of the sample solution and standard solution as directed under Liquid Chromatography <2.01> according to the following conditions, and determine each peak area by the automatic integration method: the peak area of parahydroxybenzoic acid having a relative retention time of about 0.5 to ethyl parahydroxybenzoate obtained from the sample solution is not larger than the peak area of ethyl parahydroxybenzoate from the standard solution (0.5%). For the peak area of parahydroxybenzoic acid, multiply its correction factor, 1.4. Furthermore, the area of the peak other than ethyl parahydroxybenzoate and parahydroxybenzoic acid from the sample solution is not larger than the peak area of ethyl parahydroxybenzoate from the standard solution (0.5%), and the total area of the peaks other than ethyl parahydroxybenzoate is not larger than 2 times the peak area of ethyl parahydroxybenzoate from the standard solution (1.0%). For this calculation the peak area not larger than 1/5 times the peak area of ethyl parahydroxybenzoate from the standard solution is excluded (0.1%).

Operating conditions—

Detector, column, column temperature, mobile phase, and flow rate: Proceed as directed in the operating conditions in the Assay.

Time span of measurement: About 4 times as long as the retention time of ethyl parahydroxybenzoate.

System suitability—

System performance: Proceed as directed in the system suitability in the Assay.

◆Test for required detectability: To exactly 2 mL of the standard solution add the mobile phase to make exactly 10 mL. Confirm that the peak area of ethyl parahydroxybenzoate obtained with 10 μ L of this solution is equivalent to 14 to 26% of that with 10 μ L of the standard solution.◆

◆System repeatability: When the test is repeated 6 times with 10 μ L of the standard solution under the above operating conditions, the relative standard deviation of the peak area of ethyl parahydroxybenzoate is not more than 2.0%.◆

Residue on ignition <2.44> Not more than 0.1% (1 g).

Assay Weigh accurately about 50.0 mg each of Ethyl Parahydroxybenzoate and Ethyl Parahydroxybenzoate RS, dissolve separately in 2.5 mL each of methanol, and add the mobile phase to make exactly 50 mL. Pipet 10 mL each of these solutions, add the mobile phase to make exactly 100 mL, and use these solutions as the sample solution and the standard solution, respectively. Perform the test with exactly 10 μ L each of the sample solution and standard solution as directed under Liquid Chromatography <2.01> according to the following conditions, and determine the peak areas, A_T and A_S , of ethyl parahydroxybenzoate in each solution.

$$\begin{aligned} &\text{Amount (mg) of ethyl parahydroxybenzoate (C}_9\text{H}_{10}\text{O}_3) \\ &= M_S \times A_T / A_S \end{aligned}$$

M_S : Amount (mg) of Ethyl Parahydroxybenzoate RS taken

Operating conditions—

Detector: An ultraviolet absorption photometer (wavelength: 272 nm).

Column: A stainless steel column 4.6 mm in inside diameter and 15 cm in length, packed with octadecylsilanized silica gel for liquid chromatography (5 μ m in particle diameter).

Column temperature: A constant temperature of about 35°C.

Mobile phase: A mixture of methanol and potassium dihydrogen phosphate solution (17 in 2500) (13:7).

Flow rate: 1.3 mL per minute.

System suitability—

System performance: Dissolve 5 mg each of Ethyl Parahydroxybenzoate, methyl parahydroxybenzoate and parahydroxybenzoic acid in the mobile phase to make exactly 100 mL. Pipet 1 mL of this solution, and add the mobile phase to make exactly 10 mL. When the procedure is run with 10 μ L of this solution under the above operating conditions, parahydroxybenzoic acid, methyl parahydroxybenzoate and ethyl parahydroxybenzoate are eluted in this order, the relative retention times of parahydroxybenzoic acid and methyl parahydroxybenzoate to ethyl parahydroxybenzoate are about 0.5 and about 0.8, respectively, and the resolution between the peaks of methyl parahydroxybenzoate and ethyl parahydroxybenzoate is not less than 2.0.

System repeatability: When the test is repeated 6 times with 10 μ L of the standard solution under the above operating conditions, the relative standard deviation of the peak area of ethyl parahydroxybenzoate is not more than 0.85%.

◆**Containers and storage** Containers—Well-closed containers.◆

Etidronate Disodium

エチドロン酸二ナトリウム

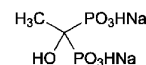

$\text{C}_2\text{H}_6\text{Na}_2\text{O}_7\text{P}_2$: 249.99

Disodium dihydrogen 1-hydroxyethane-1,1-diyldiphosphonate [7414-83-7]

Etidronate Disodium, when dried, contains not less than 98.0% and not more than 101.0% of etidronate disodium ($\text{C}_2\text{H}_6\text{Na}_2\text{O}_7\text{P}_2$).

Description Etidronate Disodium occurs as a white powder.

It is freely soluble in water, and practically insoluble in

ethanol (99.5).

The pH of a solution prepared by dissolving 0.10 g of Etidronate Disodium in 10 mL of water is between 4.4 and 5.4.

It is hygroscopic.

Identification (1) To 5 mL of a solution of Etidronate Disodium (1 in 100) add 1 mL of copper (II) sulfate TS, and mix for 10 minutes: a blue precipitate is formed.

(2) Determine the infrared absorption spectrum of Etidronate Disodium, previously dried, as directed in the potassium bromide disk method under Infrared Spectrophotometry <2.25>, and compare the spectrum with the Reference Spectrum: both spectra exhibit similar intensities of absorption at the same wave numbers.

(3) A solution of Etidronate Disodium (1 in 100) responds to Qualitative Tests <1.09> for sodium salt.

Purity (1) Heavy metals <1.07>—Proceed with 1.0 g of Etidronate Disodium according to Method 4, and perform the test using the supernatant liquid obtained by centrifuging after addition of 2 mL of dilute acetic acid. Prepare the control solution with 2.0 mL of Standard Lead Solution (not more than 20 ppm).

(2) Arsenic <1.11>—Prepare the test solution with 1.0 g of Etidronate Disodium according to Method 1, and perform the test (not more than 2 ppm).

(3) Phosphite—Weigh accurately about 3.5 g of Etidronate Disodium, dissolve in 100 mL of 0.1 mol/L sodium dihydrogen phosphate TS adjusted the pH to 8.0 with sodium hydroxide TS, add exactly 20 mL of 0.05 mol/L iodine VS, and immediately stopper tightly. Allow to stand in a dark place for 30 minutes, add 1 mL of acetic acid (100), and titrate <2.50> the excess of iodine with 0.1 mol/L sodium thiosulfate VS (indicator: 1 mL of starch TS). Perform a blank determination in the same manner. The amount of phosphite (NaH_2PO_3) is not more than 1.0%.

Each mL of 0.05 mol/L iodine VS = 5.199 mg of NaH_2PO_3

(4) Methanol—Weigh accurately about 0.5 g of Etidronate Disodium, dissolve in water to make exactly 5 mL, and use this solution as the sample solution. Separately, pipet 1 mL of methanol, and add water to make exactly 100 mL. Pipet 1 mL of this solution, add water to make exactly 100 mL, and use this solution as the standard solution. Perform the test with exactly 1 μL each of the sample solution and standard solution as directed under Gas Chromatography <2.02> according to the following conditions, and determine the peak areas, A_T and A_S , of methanol in each solution and determine the amount of methanol (CH_4O) by the following equation: not more than 0.1%.

$$\begin{aligned} \text{Amount (\%)} \text{ of methanol (CH}_4\text{O)} \\ = 1/M \times A_T/A_S \times 1/20 \times 0.79 \end{aligned}$$

M : Amount (g) of Etidronate Disodium taken
0.79: Density (g/mL) of methanol

Operating conditions—

Detector: A hydrogen flame-ionization detector.

Column: A glass column 3 mm in inside diameter and 2 m in length, packed with porous copolymer beads for gas chromatography (180 – 250 μm in particle diameter).

Column temperature: A constant temperature of about 130°C.

Carrier gas: Nitrogen.

Flow rate: Adjust so that the retention time of methanol is about 2 minutes.

System suitability—

System performance: To 1 mL of methanol and 1 mL of ethanol (99.5) add water to make 100 mL. To 1 mL of this solution add water to make 100 mL. When the procedure is run with 1 μL of this solution under the above operating conditions, methanol and ethanol are eluted in this order with the resolution between these peaks being not less than 2.0.

System repeatability: When the test is repeated 6 times with 1 μL of the standard solution under the above operating conditions, the relative standard deviation of the peak area of methanol is not more than 5.0%.

Loss on drying <2.41> Not more than 5.0% (0.5 g, 210°C, 2 hours).

Assay Weigh accurately about 0.5 g of Etidronate Disodium, previously dried, and dissolve in water to make exactly 50 mL. Transfer exactly 15 mL of this solution to a chromatographic column of 10 mm in internal diameter containing 5 mL of strongly acidic ion exchange resin for column chromatography (H type), allow to flow at a flow rate of about 1.5 mL per minute, and wash the column with two 25-mL portions of water. Combine the eluate and the washings, and titrate <2.50> with 0.1 mol/L sodium hydroxide VS (potentiometric titration). Perform a blank determination in the same manner, and make any necessary correction.

$$\begin{aligned} \text{Each mL of 0.1 mol/L sodium hydroxide VS} \\ = 12.50 \text{ mg of } \text{C}_2\text{H}_6\text{Na}_2\text{O}_7\text{P}_2 \end{aligned}$$

Containers and storage Containers—Tight containers.

Etidronate Disodium Tablets

エチドロロン酸二ナトリウム錠

Etidronate Disodium Tablets contain not less than 93.0% and not more than 107.0% of the labeled amount of etidronate disodium ($\text{C}_2\text{H}_6\text{Na}_2\text{O}_7\text{P}_2$: 249.99).

Method of preparation Prepare as directed under Tablets, with Etidronate Disodium.

Identification (1) Shake an amount of powdered Etidronate Disodium Tablets, equivalent to 0.2 g of Etidronate Disodium, with 20 mL of water, and filter. Proceed with the filtrate as directed in the Identification (1) under Etidronate Disodium.

(2) Shake an amount of powdered Etidronate Disodium Tablets, equivalent to 0.4 g of Etidronate Disodium, with 10 mL of water, and filter. Evaporate total amount of the filtrate to dryness under reduced pressure, shake the residue with 15 mL of ethanol (99.5), centrifuge, and dry the precipitate at 150°C for 4 hours. Determine the infrared absorption spectrum of the precipitate as directed in the potassium bromide disk method under Infrared Spectrophotometry <2.25>: it exhibits absorption at the wave numbers of about 1170 cm^{-1} , 1056 cm^{-1} , 916 cm^{-1} and 811 cm^{-1} .

Uniformity of dosage units <6.02> It meets the requirement of the Mass variation test.

Dissolution <6.10> When the test is performed at 50 revolutions per minute according to the Paddle method, using 900 mL of water as the dissolution medium, the dissolution rate in 60 minutes of Etidronate Disodium Tablets is not less than 85%.

Start the test with 1 tablet of Etidronate Disodium Tablets, withdraw not less than 20 mL of the medium at the specified minute after starting the test, and filter through a membrane filter with a pore size not exceeding 0.45 μm . Discard not less than 10 mL of the first filtrate, take exactly V mL of the subsequent filtrate, add water to make exactly V' mL so that each mL contains about 0.22 mg of etidronate disodium ($\text{C}_2\text{H}_6\text{Na}_2\text{O}_7\text{P}_2$), and use this solution as the sample solution. Separately, weigh accurately about 30 mg of etidronate disodium for assay, previously dried at 210°C for 2 hours, and dissolve in water to make exactly 100 mL. Dilute exactly a suitable amount of this solution with water to make solutions so that each mL contains about 0.12 mg, about 0.21 mg and about 0.24 mg of etidronate disodium ($\text{C}_2\text{H}_6\text{Na}_2\text{O}_7\text{P}_2$), and use these solutions as the standard solutions. Pipet 2 mL each of the sample solution and standard solutions, add exactly 2 mL of a solution of copper (II) sulfate (7 in 10,000) and water to make exactly 10 mL. Determine the absorbances of these solutions at 233 nm as directed under Ultraviolet-visible Spectrophotometry <2.24>, using a solution prepared by diluting exactly 2 mL of the solution of copper (II) sulfate (7 in 10,000) with water to make exactly 10 mL as the control. From the calibration curve obtained with the standard solutions calculate the concentration of etidronate disodium, C_T , in the sample solution.

Dissolution rate (%) with respect to the labeled amount of etidronate disodium ($\text{C}_2\text{H}_6\text{Na}_2\text{O}_7\text{P}_2$)

$$= C_T \times V'/V \times 1/C \times 90$$

C_T : Concentration ($\mu\text{g/mL}$) of etidronate disodium ($\text{C}_2\text{H}_6\text{Na}_2\text{O}_7\text{P}_2$) in the sample solution

C : Labeled amount (mg) of etidronate disodium ($\text{C}_2\text{H}_6\text{Na}_2\text{O}_7\text{P}_2$) in 1 tablet

Assay Weigh accurately and powder not less than 20 Etidronate Disodium Tablets. Weigh accurately a portion of the powder, equivalent to about 0.5 g of etidronate disodium ($\text{C}_2\text{H}_6\text{Na}_2\text{O}_7\text{P}_2$), add 30 mL of water, shake vigorously for 10 minutes, add water to make exactly 50 mL, and filter. Proceed with exactly 15 mL of the filtrate as directed in the Assay under Etidronate Disodium.

Containers and storage Containers—Tight containers.

Etilefrine Hydrochloride

エチレフリン塩酸塩

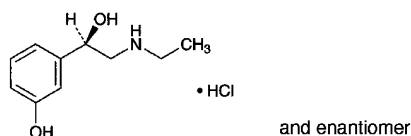

$\text{C}_{10}\text{H}_{15}\text{NO}_2 \cdot \text{HCl}$: 217.69
(1*S*)-2-Ethylamino-1-(3-hydroxyphenyl)ethanol monohydrochloride
[943-17-9]

Etilefrine Hydrochloride, when dried, contains not less than 98.0% and not more than 101.0% of etilefrine hydrochloride ($\text{C}_{10}\text{H}_{15}\text{NO}_2 \cdot \text{HCl}$).

Description Etilefrine Hydrochloride occurs as white, crystals or crystalline powder.

It is very soluble in water, freely soluble in ethanol (99.5), and sparingly soluble in acetic acid (100).

It is gradually colored to yellow-brown by light.

A solution of Etilefrine Hydrochloride (1 in 20) shows no optical rotation.

Identification (1) Dissolve 5 mg of Etilefrine Hydrochloride in 100 mL of diluted hydrochloric acid (1 in 1000). Determine the absorption spectrum of the solution as directed under Ultraviolet-visible Spectrophotometry <2.24>, and compare the spectrum with the Reference Spectrum: both spectra exhibit similar intensities of absorption at the same wavelengths.

(2) Determine the infrared absorption spectrum of Etilefrine Hydrochloride, previously dried, as directed in the potassium chloride disk method under Infrared Spectrophotometry <2.25>, and compare the spectrum with the Reference Spectrum: both spectra exhibit similar intensities of absorption at the same wave numbers.

(3) A solution of Etilefrine Hydrochloride (1 in 1000) responds to Qualitative Tests <1.09> (2) for chloride.

Melting point <2.60> 118 – 122°C

Purity (1) Clarity and color of solution—Dissolve 0.5 g of Etilefrine Hydrochloride in 10 mL of water: the solution is clear and colorless.

(2) Acidity or alkalinity—To 10 mL of a solution of Etilefrine Hydrochloride (1 in 50) add 0.1 mL of methyl red TS for acid or alkali test and 0.2 mL of 0.01 mol/L sodium hydroxide VS: a yellow color develops, and the necessary volume of 0.01 mol/L hydrochloric acid VS to change the color to red is not more than 0.4 mL.

(3) Sulfate <1.14>—Perform the test with 0.85 g of Etilefrine Hydrochloride. Prepare the control solution with 0.35 mL of 0.005 mol/L sulfuric acid VS (not more than 0.020%).

(4) Heavy metals <1.07>—Dissolve 1.0 g of Etilefrine Hydrochloride in 30 mL of water and 2 mL of acetic acid (100), adjust with sodium hydroxide TS to a pH of 3.3, add water to make 50 mL, and perform the test. Prepare the control solution with 2.0 mL of Standard Lead Solution (not more than 20 ppm).

Loss on drying <2.41> Not more than 0.5% (1 g, 105°C, 4 hours).

Residue on ignition <2.44> Not more than 0.1% (1 g).

Assay Weigh accurately about 0.15 g of Etilefrine Hydrochloride, previously dried, dissolve in 20 mL of acetic acid (100), add 50 mL of acetic anhydride, and titrate <2.50> with 0.1 mol/L perchloric acid VS (potentiometric titration). Perform a blank determination in the same manner, and make any necessary correction.

Each mL of 0.1 mol/L perchloric acid VS
= 21.77 mg of $\text{C}_{10}\text{H}_{15}\text{NO}_2 \cdot \text{HCl}$

Containers and storage Containers—Tight containers.
Storage—Light-resistant.

Etilefrine Hydrochloride Tablets

エチレフリン塩酸塩錠

Etilefrine Hydrochloride Tablets contain not less than 93.0% and not more than 107.0% of the labeled amount of etilefrine hydrochloride ($C_{10}H_{15}NO_2 \cdot HCl$; 217.69).

Method of preparation Prepare as directed under Tablets, with Etilefrine Hydrochloride.

Identification To a quantity of powdered Etilefrine Hydrochloride Tablets, equivalent to 5 mg of Etilefrine Hydrochloride, add 60 mL of diluted hydrochloric acid (1 in 1000), shake well, add 40 mL of diluted hydrochloric acid (1 in 1000), and filter. Determine the absorption spectrum of the filtrate as directed under Ultraviolet-visible Spectrophotometry <2.24>, using diluted hydrochloric acid (1 in 1000) as the blank: it exhibits a maximum between 271 nm and 275 nm.

Uniformity of dosage units <6.02> Perform the test according to the following method: it meets the requirements of the Content uniformity test.

To 1 tablet of Etilefrine Hydrochloride Tablets add 60 mL of diluted hydrochloric acid (1 in 1000), and proceed as directed in the Assay.

$$\begin{aligned} \text{Amount (mg) of etilefrine hydrochloride (C}_{10}\text{H}_{15}\text{NO}_2\text{.HCl)} \\ = M_S \times A_T/A_S \times 1/10 \end{aligned}$$

M_S : Amount (mg) of etilefrine hydrochloride for assay taken

Dissolution <6.10> When the test is performed at 50 revolutions per minute according to the Paddle method, using 900 mL of water as the dissolution medium, the dissolution rate in 30 minutes of Etilefrine Hydrochloride Tablets is not less than 70%.

Start the test with 1 tablet of Etilefrine Hydrochloride Tablets, withdraw not less than 20 mL of the medium at the specified minute after starting the test, and filter through a membrane filter with a pore size not exceeding 0.45 μm . Discard not less than 10 mL of the first filtrate, pipet V mL of the subsequent filtrate, add water to make exactly V' mL so that each mL contains about 5 μg of etilefrine hydrochloride ($C_{10}H_{15}NO_2 \cdot HCl$), and use this solution as the sample solution. Separately, weigh accurately about 25 mg of etilefrine hydrochloride for assay, previously dried at 105°C for 4 hours, and dissolve in water to make exactly 50 mL. Pipet 1 mL of this solution, add water to make exactly 100 mL, and use this solution as the standard solution. Perform the test with exactly 20 μL each of the sample solution and standard solution as directed under Liquid Chromatography <2.01> according to the following conditions, and determine the peak areas, A_T and A_S , of etilefrine in each solution.

$$\begin{aligned} \text{Dissolution rate (\%)} \text{ with respect to the labeled amount} \\ \text{of etilefrine hydrochloride (C}_{10}\text{H}_{15}\text{NO}_2\text{.HCl)} \\ = M_S \times A_T/A_S \times V'/V \times 1/C \times 18 \end{aligned}$$

M_S : Amount (mg) of etilefrine hydrochloride for assay taken

C : Labeled amount (mg) of etilefrine hydrochloride ($C_{10}H_{15}NO_2 \cdot HCl$) in 1 tablet.

Operating conditions—

Proceed as directed in the operating conditions in the Assay.

System suitability—

System performance: When the procedure is run with 20 μL of the standard solution under the above operating conditions, the number of theoretical plates and the symmetry factor of the peak of etilefrine are not less than 8000 and 0.9 – 1.2, respectively.

System repeatability: When the test is repeated 6 times with 20 μL of the standard solution under the above operating conditions, the relative standard deviation of the peak area of etilefrine is not more than 2.0%.

Assay Weigh accurately the mass of not less than 20 Etilefrine Hydrochloride Tablets, and powder. Weigh accurately a portion of the powder, equivalent to about 5 mg of etilefrine hydrochloride ($C_{10}H_{15}NO_2 \cdot HCl$), add 60 mL of diluted hydrochloric acid (1 in 1000), shake for 10 minutes, add diluted hydrochloric acid (1 in 1000) to make exactly 100 mL, and filter. Discard the first 20 mL of the filtrate, and use the subsequent filtrate as the sample solution. Separately, weigh accurately about 50 mg of etilefrine hydrochloride for assay, previously dried at 105°C for 4 hours, and dissolve in diluted hydrochloric acid (1 in 1000) to make exactly 100 mL. Pipet 10 mL of this solution, add diluted hydrochloric acid (1 in 1000) to make exactly 100 mL, and use this solution as the standard solution. Perform the test with exactly 20 μL each of the sample solution and standard solution as directed under Liquid Chromatography <2.01> according to the following conditions, and determine the peak areas, A_T and A_S , of etilefrine in each solution.

$$\begin{aligned} \text{Amount (mg) of etilefrine hydrochloride (C}_{10}\text{H}_{15}\text{NO}_2\text{.HCl)} \\ = M_S \times A_T/A_S \times 1/10 \end{aligned}$$

M_S : Amount (mg) of etilefrine hydrochloride for assay taken

Operating conditions—

Detector: An ultraviolet absorption photometer (wavelength: 220 nm).

Column: A stainless steel column 4.6 mm in inside diameter and 25 cm in length, packed with octylsilylated silica gel for liquid chromatography (5 μm in particle diameter).

Column temperature: A constant temperature of about 40°C.

Mobile phase: Dissolve 5 g of sodium lauryl sulfate in 940 mL of water and 500 mL of acetonitrile, and adjust the pH to 2.3 with phosphoric acid.

Flow rate: Adjust so that the retention time of etilefrine is about 6 minutes.

System suitability—

System performance: Dissolve 4 mg of bamethan sulfate and 4 mg of etilefrine hydrochloride in the mobile phase to make 50 mL. When the procedure is run with 20 μL of this solution under the above operating conditions, etilefrine and bamethan are eluted in this order with the resolution between these peaks being not less than 5.

System repeatability: When the test is repeated 6 times with 20 μL of the standard solution under the above operating conditions, the relative standard deviation of the peak area of etilefrine is not more than 1.0%.

Containers and storage Containers—Tight containers.

Storage—Light-resistant.

Etizolam

エチゾラム

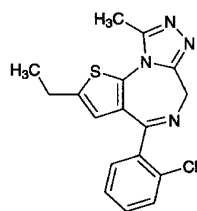

$C_{17}H_{15}ClN_4S$: 342.85

4-(2-Chlorophenyl)-2-ethyl-9-methyl-6*H*-thieno[3,2-*f*][1,2,4]triazolo[4,3-*a*][1,4]diazepine
[40054-69-1]

Etizolam, when dried, contains not less than 98.5% and not more than 101.0% of etizolam ($C_{17}H_{15}ClN_4S$).

Description Etizolam occurs as a white to pale yellow-white crystalline powder.

It is soluble in ethanol (99.5), sparingly soluble in acetonitrile and in acetic anhydride, and practically insoluble in water.

Identification (1) Determine the absorption spectrum of a solution of Etizolam in ethanol (99.5) (1 in 100,000) as directed under Ultraviolet-visible Spectrophotometry <2.24>, and compare the spectrum with the Reference Spectrum: both spectra exhibit similar intensities of absorption at the same wavelengths.

(2) Determine the infrared absorption spectrum of Etizolam as directed in the potassium bromide disk method under Infrared Spectrophotometry <2.25>, and compare the spectrum with the Reference Spectrum: both spectra exhibit similar intensities of absorption at the same wave numbers.

Melting point <2.60> 147 – 151°C

Purity (1) Heavy metals <1.07>—Proceed with 2.0 g of Etizolam according to Method 2, and perform the test. Prepare the control solution with 2.0 mL of Standard Lead Solution (not more than 10 ppm).

(2) Related substances—Dissolve 20 mg of Etizolam in 50 mL of acetonitrile, and use this solution as the sample solution. Pipet 1 mL of the sample solution, and add acetonitrile to make exactly 20 mL. Pipet 1 mL of this solution, add acetonitrile to make exactly 50 mL, and use this solution as the standard solution. Perform the test with exactly 10 μ L each of the sample solution and standard solution as directed under Liquid Chromatography <2.01> according to the following conditions, and determine each peak area by the automatic integration method: the area of the peak other than etizolam obtained from the sample solution is not larger than the peak area of etizolam from the standard solution.

Operating conditions—

Detector: An ultraviolet absorption photometer (wavelength: 240 nm).

Column: A stainless steel column 4.6 mm in inside diameter and 15 cm in length, packed with octadecylsilanized silica gel for liquid chromatography (5 μ m in particle diameter).

Column temperature: A constant temperature of about 35°C.

Mobile phase: Dissolve 1.36 g of potassium dihydrogen phosphate in water to make 1000 mL, and adjust the pH to 3.5 with diluted phosphoric acid (1 in 10). To 550 mL of this solution add 450 mL of acetonitrile.

Flow rate: Adjust so that the retention time of etizolam is about 6 minutes.

Time span of measurement: About 5 times as long as the retention time of etizolam, beginning after the solvent peak.

System suitability—

Test for required detectability: Measure exactly 2 mL of the standard solution, and add acetonitrile to make exactly 20 mL. Confirm that the peak area of etizolam obtained with 10 μ L of this solution is equivalent to 8 to 12% of that with 10 μ L of the standard solution.

System performance: Dissolve 0.02 g each of Etizolam and ethyl parahydroxybenzoate in the mobile phase to make 50 mL. To 1 mL of this solution add the mobile phase to make 50 mL. When the procedure is run with 10 μ L of this solution under the above operating conditions, ethyl parahydroxybenzoate and etizolam are eluted in this order with the resolution between these peaks being not less than 3.

System repeatability: When the test is repeated 6 times with 10 μ L of the standard solution under the above operating conditions, the relative standard deviation of the peak area of etizolam is not more than 2%.

Loss on drying <2.41> Not more than 0.5% (1 g, 105°C, 3 hours).

Residue on ignition <2.44> Not more than 0.1% (1 g).

Assay Weigh accurately about 0.3 g of Etizolam, previously dried, dissolve in 70 mL of a mixture of acetic anhydride and acetic acid (100) (7:3), and titrate <2.50> with 0.1 mol/L perchloric acid VS (potentiometric titration). The end point is the second equivalent point. Perform a blank determination in the same manner, and make any necessary correction.

Each mL of 0.1 mol/L perchloric acid VS
= 17.14 mg of $C_{17}H_{15}ClN_4S$

Containers and storage Containers—Tight containers.

Storage—Light-resistant.

Etizolam Fine Granules

エチゾラム細粒

Etizolam Fine Granules contain not less than 93.0% and not more than 107.0% of the labeled amount of etizolam ($C_{17}H_{15}ClN_4S$: 342.85).

Method of preparation Prepare as directed under Granules, with Etizolam.

Identification (1) To a quantity of powdered Etizolam Fine Granules, equivalent to 5 mg of Etizolam, add 10 mL of methanol, shake, and filter through a membrane filter with a pore size not exceeding 0.45 μ m. Evaporate the filtrate to dryness on a water bath, cool, and then dissolve the residue in 2 mL of sulfuric acid. The solution gives off a light yellow-green fluorescent when exposed to ultraviolet light (main wavelength: 365 nm).

(2) To a quantity of powdered Etizolam Fine Granules, equivalent to 1 mg of Etizolam, add 80 mL of 0.1 mol/L hydrochloric acid TS, shake, and then filter. Determine the absorption spectrum of the filtrate as directed under Ultraviolet-visible Spectrophotometry <2.24>: it exhibits absorption maxima between 249 nm and 253 nm, and between 292 nm and 296 nm, when perform the measurement within 10 minutes.

Uniformity of dosage units <6.02> The Granules in single-dose packages meet the requirement of the Mass variation test.

Dissolution <6.10> When the test is performed at 50 revolutions per minute according to the Paddle method, using 900 mL of water as the dissolution medium, the dissolution rate in 30 minutes of Etizolam Fine Granules is not less than 75%.

Start the test with an accurately weighed amount of Etizolam Fine Granules, equivalent to about 1 mg of etizolam ($C_{17}H_{15}ClN_4S$), withdraw not less than 20 mL of the medium at the specified minute after starting the test, and filter through a membrane filter with a pore size not exceeding $0.45\ \mu\text{m}$. Discard not less than 10 mL of first filtrate, pipet 2 mL of the subsequent filtrate, add exactly 2 mL of acetonitrile, and use this solution as the sample solution. Separately, weigh accurately about 28 mg of etizolam for assay, previously dried at 105°C for 3 hours, and dissolve in methanol to make exactly 50 mL. Pipet 5 mL of this solution, and add water to make exactly 100 mL. Pipet 4 mL of this solution, and add water to make exactly 100 mL. Pipet 2 mL of this solution, add exactly 2 mL of acetonitrile, and use this solution as the standard solution. Perform the test with exactly $50\ \mu\text{L}$ each of the sample solution and standard solution as directed under Liquid Chromatography <2.01> according to the following conditions, and determine the peak areas, A_T and A_S , of etizolam in each solution.

Dissolution rate (%) with respect to the labeled amount of etizolam ($C_{17}H_{15}ClN_4S$)
 $= M_S/M_T \times A_T/A_S \times 1/C \times 18/5$

M_S : Amount (mg) of etizolam for assay taken

M_T : Amount (g) of Etizolam Fine Granules taken

C : Labeled amount (mg) of etizolam ($C_{17}H_{15}ClN_4S$) in 1 g

Operating conditions—

Detector: An ultraviolet absorption photometer (wavelength: 243 nm).

Column: A stainless steel column 4.6 mm in inside diameter and 15 cm in length, packed with octadecylsilanized silica gel for liquid chromatography ($5\ \mu\text{m}$ in particle diameter).

Column temperature: A constant temperature of about 30°C .

Mobile phase: A mixture of water and acetonitrile (1:1).

Flow rate: Adjust so that the retention time of etizolam is about 7 minutes.

System suitability—

System performance: When the procedure is run with $50\ \mu\text{L}$ of the standard solution under the above operating conditions, the number of theoretical plates and the symmetry factor of the peak of etizolam are not less than 3000 and not more than 2.0, respectively.

System repeatability: When the test is repeated 6 times with $50\ \mu\text{L}$ of the standard solution under the above operating conditions, the relative standard deviation of the peak area of etizolam is not more than 2.0%.

Assay Weigh accurately an amount of powdered Etizolam Fine Granules, equivalent to about 4 mg of etizolam ($C_{17}H_{15}ClN_4S$), add 30 mL of water, and stir. Add 60 mL of methanol, stir for 20 minutes, add methanol to make exactly 100 mL, and centrifuge. Pipet 5 mL of the supernatant liquid, add exactly 10 mL of the internal standard solution, add diluted methanol (7 in 10) to make 25 mL, and use this solution as the sample solution. Separately, weigh accurately about 0.1 g of etizolam for assay, previously dried at 105°C for 3 hours, and dissolve in diluted methanol (7 in 10) to

make exactly 100 mL. Pipet 2 mL of this solution, and add diluted methanol (7 in 10) to make exactly 100 mL. Pipet 10 mL of this solution, add exactly 10 mL of the internal standard solution, add diluted methanol (7 in 10) to make 25 mL, and use this solution as the standard solution. Perform the test with $10\ \mu\text{L}$ each of the sample solution and standard solution as directed under Liquid Chromatography <2.01> according to the following conditions, and calculate the ratios, Q_T and Q_S , of the peak area of etizolam to that of the internal standard.

$$\begin{aligned} &\text{Amount (mg) of etizolam } (C_{17}H_{15}ClN_4S) \\ &= M_S \times Q_T/Q_S \times 1/25 \end{aligned}$$

M_S : Amount (mg) of etizolam for assay taken

Internal standard solution—A solution of ethyl parahydroxybenzoate in diluted methanol (7 in 10) (1 in 50,000).

Operating conditions—

Detector: An ultraviolet absorption photometer (wavelength: 240 nm).

Column: A stainless steel column 4.6 mm in inside diameter and 15 cm in length, packed with octadecylsilanized silica gel for liquid chromatography ($5\ \mu\text{m}$ in particle diameter).

Column temperature: A constant temperature of about 35°C .

Mobile phase: Dissolve 1.36 g of potassium dihydrogen phosphate in water to make 1000 mL, and adjust the pH to 3.5 with diluted phosphoric acid (1 in 10). To 550 mL of this solution add 450 mL of acetonitrile.

Flow rate: Adjust so that the retention time of etizolam is about 6 minutes.

System suitability—

System performance: When the procedure is run with $10\ \mu\text{L}$ of the standard solution under the above operating conditions, the internal standard and etizolam are eluted in this order with the resolution between these peaks being not less than 3.

System repeatability: When the test is repeated 6 times with $10\ \mu\text{L}$ of the standard solution under the above operating conditions, the relative standard deviation of the ratio of the peak area of etizolam to that of the internal standard is not more than 1.0%.

Containers and storage Containers—Tight containers.

Storage—Light-resistant.

Etizolam Tablets

エチゾラム錠

Etizolam Tablets contain not less than 93.0% and not more than 107.0% of the labeled amount of etizolam ($C_{17}H_{15}ClN_4S$: 342.85).

Method of preparation Prepare as directed under Tablets, with Etizolam.

Identification (1) To a quantity of powdered Etizolam Tablets, equivalent to 5 mg of Etizolam, add 10 mL of methanol, shake, and filter. Evaporate the filtrate to dryness on a water bath, and dissolve the residue in 2 mL of sulfuric acid. The solution gives off a light yellow-green fluorescence when exposed to ultraviolet light (main wavelength: 365 nm).

(2) To a quantity of powdered Etizolam Tablets, equivalent to 1 mg of Etizolam, add 80 mL of 0.1 mol/L hydrochloric acid TS, shake, and then filter through a membrane filter with a pore size not exceeding $0.45\ \mu\text{m}$. Deter-

mine the absorption spectrum of this filtrate as directed under Ultraviolet-visible Spectrophotometry <2.24>: it exhibits absorption maxima between 249 nm and 253 nm, and between 292 nm and 296 nm when perform the measurement within 10 minutes.

Uniformity of dosage units <6.02> Perform the test according to the following method: it meets the requirement of the Content uniformity test.

To 1 tablet of Etizolam Tablets add 2.5 mL of water, and stir until the tablet is disintegrated. Add 20 mL of methanol, stir for 20 minutes, add methanol to make exactly 25 mL, and centrifuge. Pipet V mL of the supernatant liquid, add exactly 2 mL of the internal standard solution, add diluted methanol (9 in 10) to make 25 mL so that each mL contains about 8 μg of etizolam ($\text{C}_{17}\text{H}_{15}\text{ClN}_4\text{S}$), and use this solution as the sample solution. Then, proceed as directed in the Assay.

$$\begin{aligned} & \text{Amount (mg) of etizolam (C}_{17}\text{H}_{15}\text{ClN}_4\text{S)} \\ & = M_S \times Q_T/Q_S \times 1/V \times 1/20 \end{aligned}$$

M_S : Amount (mg) of etizolam for assay taken

Internal standard solution—A solution of ethyl parahydroxybenzoate in diluted methanol (9 in 10) (1 in 10,000).

Dissolution <6.10> When the test is performed at 50 revolutions per minute according to the Paddle method, using 900 mL of water as the dissolution medium, the dissolution rate in 30 minutes of Etizolam Tablets is not less than 70%.

Start the test with 1 tablet of Etizolam Tablets, withdraw not less than 20 mL of the medium at the specified minute after starting the test, and filter through a membrane filter with a pore size not exceeding 0.45 μm . Discard not less than 10 mL of the first filtrate, pipet V mL of the subsequent filtrate, add water to make exactly V' mL so that each mL contains about 0.28 μg of etizolam ($\text{C}_{17}\text{H}_{15}\text{ClN}_4\text{S}$). Pipet 2 mL of this solution, add exactly 2 mL of acetonitrile, and use this solution as the sample solution. Separately, weigh accurately about 28 mg of etizolam for assay, previously dried at 105°C for 3 hours, dissolve in 50 mL of methanol, and add water to make exactly 100 mL. Pipet 5 mL of this solution, add water to make exactly 100 mL. Pipet 2 mL of this solution, add water to make exactly 100 mL. Pipet 2 mL of this solution, add exactly 2 mL of acetonitrile, and use this solution as the standard solution. Perform the test with exactly 100 μL each of the sample solution and standard solution as directed under Liquid Chromatography <2.01> according to the following conditions, and determine the peak areas, A_T and A_S , of etizolam in each solution.

$$\begin{aligned} & \text{Dissolution rate (\%)} \text{ with respect to the labeled amount} \\ & \text{of etizolam (C}_{17}\text{H}_{15}\text{ClN}_4\text{S)} \\ & = M_S \times A_T/A_S \times V'/V \times 1/C \times 9/10 \end{aligned}$$

M_S : Amount (mg) of etizolam for assay taken

C : Labeled amount (mg) of etizolam ($\text{C}_{17}\text{H}_{15}\text{ClN}_4\text{S}$) in 1 tablet

Operating conditions—

Detector: An ultraviolet absorption photometer (wavelength: 243 nm).

Column: A stainless steel column 4.6 mm in inside diameter and 15 cm in length, packed with octadecylsilanized silica gel for liquid chromatography (5 μm in particle diameter).

Column temperature: A constant temperature of about 30°C.

Mobile phase: A mixture of water and acetonitrile (1:1).

Flow rate: Adjust so that the retention time of etizolam is about 7 minutes.

System suitability—

System performance: When the procedure is run with 100 μL of the standard solution under the above operating conditions, the number of theoretical plates and the symmetry factor of the peak of etizolam are not less than 3000 and not more than 2.0, respectively.

System repeatability: When the test is repeated 6 times with 100 μL of the standard solution under the above operating conditions, the relative standard deviation of the peak area of etizolam is not more than 2.0%.

Assay To 20 Etizolam Tablets add 50 mL of water, and stir until they disintegrate. Add 400 mL of methanol, stir for 20 minutes, add methanol to make exactly 500 mL, and centrifuge. Pipet an amount of the supernatant liquid, equivalent to about 0.2 mg of etizolam ($\text{C}_{17}\text{H}_{15}\text{ClN}_4\text{S}$), add exactly 2 mL of the internal standard solution, add diluted methanol (9 in 10) to make 25 mL, and use this solution as the sample solution. Separately, weigh accurately about 100 mg of etizolam for assay, previously dried at 105°C for 3 hours, and dissolve in diluted methanol (9 in 10) to make exactly 100 mL. Pipet 2 mL of this solution, and add diluted methanol (9 in 10) to make exactly 100 mL. Pipet 10 mL of this solution, add exactly 2 mL of the internal standard solution, add diluted methanol (9 in 10) to make 25 mL, and use this solution as the standard solution. Perform the test with 10 μL each of the sample solution and standard solution as directed under Liquid Chromatography <2.01> according to the following conditions, and calculate the ratios, Q_T and Q_S , of the peak area of etizolam to that of the internal standard.

$$\begin{aligned} & \text{Amount (mg) of etizolam (C}_{17}\text{H}_{15}\text{ClN}_4\text{S)} \\ & = M_S \times Q_T/Q_S \times 1/500 \end{aligned}$$

M_S : Amount (mg) of etizolam for assay taken

Internal standard solution—A solution of ethyl parahydroxybenzoate in diluted methanol (9 in 10) (1 in 10,000).

Operating conditions—

Detector: An ultraviolet absorption photometer (wavelength: 240 nm).

Column: A stainless steel column 4.6 mm in inside diameter and 15 cm in length, packed with octadecylsilanized silica gel for liquid chromatography (5 μm in particle diameter).

Column temperature: A constant temperature of about 35°C.

Mobile phase: Dissolve 1.36 g of potassium dihydrogen phosphate in water to make 1000 mL, and adjust the pH to 3.5 with diluted phosphoric acid (1 in 10). To 550 mL of this solution add 450 mL of acetonitrile.

Flow rate: Adjust so that the retention time of etizolam is about 6 minutes.

System suitability—

System performance: When the procedure is run with 10 μL of the standard solution under the above operating conditions, the internal standard and etizolam are eluted in this order with the resolution between these peaks being not less than 3.

System repeatability: When the test is repeated 6 times with 10 μL of the standard solution under the above operating conditions, the relative standard deviation of the ratio of the peak area of etizolam to that of the internal standard is not more than 1.0%.

Containers and storage Containers—Tight containers.

Storage—Light-resistant.

Etodolac

エトドラク

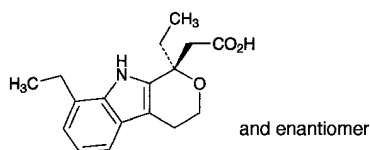

$C_{17}H_{21}NO_3$: 287.35
2-[(1*RS*)-1,8-Diethyl-1,3,4,9-tetrahydropyrano[3,4-*b*]indol-1-yl]acetic acid
[41340-25-4]

Etodolac, when dried, contains not less than 98.5% and not more than 101.0% of etodolac ($C_{17}H_{21}NO_3$).

Description Etodolac occurs as white to pale yellow, crystals or crystalline powder.

It is freely soluble in methanol and in ethanol (99.5), and practically insoluble in water.

A solution of Etodolac in methanol (1 in 50) shows no optical rotation.

Melting point: about 147°C (with decomposition).

Identification (1) Determine the absorption spectrum of a solution of Etodolac in ethanol (99.5) (3 in 200,000) as directed under Ultraviolet-visible Spectrophotometry <2.24>, and compare the spectrum with the Reference Spectrum: both spectra exhibit similar intensities of absorption at the same wavelengths.

(2) Determine the infrared absorption spectrum of Etodolac as directed in the potassium bromide disk method under Infrared Spectrophotometry <2.25>, and compare the spectrum with the Reference Spectrum: both spectra exhibit similar intensities of absorption at the same wave numbers.

Purity (1) Heavy metals <1.07>—Proceed with 2.0 g of Etodolac according to Method 2, and perform the test. Prepare the control solution with 2.0 mL of Standard Lead Solution (not more than 10 ppm).

(2) Related substances—Dissolve 0.5 g of Etodolac in 10 mL of methanol, and use this solution as the sample solution. Pipet 2 mL of the sample solution, and add methanol to make exactly 100 mL. Pipet 5 mL of this solution, add methanol to make exactly 20 mL, and use this solution as the standard solution (1). Pipet 4 mL of the standard solution (1), add methanol to make exactly 10 mL, and use this solution as the standard solution (2). Perform the test with these solutions as directed under Thin-layer Chromatography <2.03>. Previously develop a plate of silica gel with fluorescent indicator for thin-layer chromatography in a developing container containing 2 cm depth of a solution of L-ascorbic acid in a mixture of methanol and water (4:1) (1 in 200 mL) to the distance of 3 cm, and air-dry for 30 minutes. Spot 10 μ L each of the sample solution and standard solutions (1) and (2) on the plate 2.5 cm away from the bottom of the plate, then immediately develop with a mixture of toluene, ethanol (95) and acetic acid (100) (140:60:1) to a distance of about 15 cm, and air-dry the plate. Examine under ultraviolet light (main wavelength: 254 nm): any spot other than the principal spot obtained with the sample solution is not more intense than the spot with the standard solution (1), and the number of spots which are more intense than the spot with the standard solution (2) is not more than 2.

Loss on drying <2.41> Not more than 0.5% (1 g, in vacu-

um, 60°C, 4 hours).

Residue on ignition <2.44> Not more than 0.1% (1 g).

Assay Weigh accurately about 0.3 g of Etodolac, previously dried, dissolve in 50 mL of ethanol (99.5), and titrate <2.50> with 0.1 mol/L sodium hydroxide VS (potentiometric titration). Perform a blank determination in the same manner, and make any necessary correction.

Each mL of 0.1 mol/L sodium hydroxide VS
= 28.74 mg of $C_{17}H_{21}NO_3$

Containers and storage Containers—Tight containers.
Storage—Light-resistant.

Etoposide

エトポシド

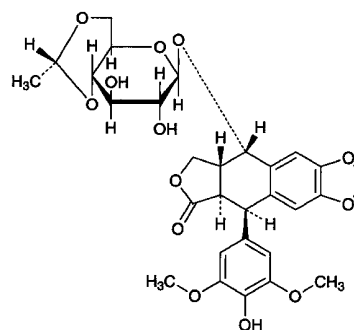

$C_{29}H_{32}O_{13}$: 588.56
(5*R*,5*aR*,8*aR*,9*S*)-9-[[4,6-*O*-(1*R*)-Ethylidene- β -D-glucopyranosyl]oxy]5-(4-hydroxy-3,5-dimethoxyphenyl)-5,8,8*a*,9-tetrahydrofuro[3',4':6,7]naphtho[2,3-*d*]-1,3-dioxol-6(5*aH*)-one
[33419-42-0]

Etoposide contains not less than 98.0% and not more than 102.0% of etoposide ($C_{29}H_{32}O_{13}$), calculated on the anhydrous basis.

Description Etoposide occurs as white, crystals or crystalline powder.

It is sparingly soluble in methanol, slightly soluble in ethanol (99.5), and very slightly soluble in water.

Melting point: about 260°C (with decomposition).

Identification (1) Determine the absorption spectrum of a solution of Etoposide in methanol (1 in 10,000) as directed under Ultraviolet-visible Spectrophotometry <2.24>, and compare the spectrum with the Reference Spectrum or the spectrum of a solution of Etoposide RS prepared in the same manner as the sample solution: both spectra exhibit similar intensities of absorption at the same wavelengths.

(2) Determine the infrared absorption spectrum of Etoposide as directed in the potassium bromide disk method under Infrared Spectrophotometry <2.25>, and compare the spectrum with the Reference Spectrum or the spectrum of Etoposide RS: both spectra exhibit similar intensities of absorption at the same wave numbers.

Optical rotation <2.49> $[\alpha]_D^{20}$: -100 – -105° (0.1 g calculated on the anhydrous basis, methanol, 20 mL, 100 mm).

Purity (1) Heavy metals <1.07>—Proceed with 2.0 g of Etoposide according to Method 2, and perform the test. Prepare the control solution with 2.0 mL of Standard Lead So-

lution (not more than 10 ppm).

(2) Related substances—Dissolve 50 mg of Etoposide in 10 mL of methanol, add the mobile phase to make 50 mL, and use this solution as the sample solution. Pipet 2 mL of the sample solution, add the mobile phase to make exactly 200 mL, and use this solution as the standard solution. Perform the test with exactly 50 μ L each of the sample solution and standard solution as directed under Liquid Chromatography <2.01> according to the following conditions, and determine each peak area by the automatic integration method: the area of the peak other than etoposide obtained from the sample solution is not larger than 1/5 times the peak area of etoposide from the standard solution, and the total area of the peaks other than etoposide is not larger than 1/2 times the peak area of etoposide from the standard solution.

Operating conditions—

Detector, column, column temperature, mobile phase, and flow rate: Proceed as directed in the operating conditions in the Assay.

Time span of measurement: About 3 times as long as the retention time of etoposide, beginning after the solvent peak.

System suitability—

System performance: Proceed as directed in the system suitability in the Assay.

Test for required detectability: Measure exactly 1 mL of the standard solution, and add the mobile phase to make exactly 10 mL. Confirm that the peak area of etoposide obtained with 50 μ L of this solution is equivalent to 7 to 13% of that with 50 μ L of the standard solution.

System repeatability: When the test is repeated 6 times with 50 μ L of the standard solution under the above operating conditions, the relative standard deviation of the peak area of etoposide is not more than 2.0%.

Water <2.48> Not more than 4.0% (0.5 g, volumetric titration, direct titration).

Residue on ignition <2.44> Not more than 0.1% (1 g).

Assay Weigh accurately about 25 mg each of Etoposide and Etoposide RS (previously determined the water <2.48> in the same manner as Etoposide) dissolve separately in methanol to make exactly 25 mL. Pipet 10 mL each of these solutions, add exactly 5 mL of the internal standard solution and the mobile phase to make 50 mL, and use these solutions as the sample solution and standard solution. Perform the test with 50 μ L each of the sample solution and standard solution as directed under Liquid Chromatography <2.01> according to the following conditions, and calculate the ratios, Q_T and Q_S , of the peak area of etoposide to that of the internal standard.

$$\text{Amount (mg) of etoposide (C}_{29}\text{H}_{32}\text{O}_{13}) = M_S \times Q_T/Q_S$$

M_S : Amount (mg) of Etoposide RS taken, calculated on the anhydrous basis

Internal standard solution—A solution of 2,6-dichlorophenol in methanol (3 in 2500).

Operating conditions—

Detector: An ultraviolet absorption photometer (wavelength: 290 nm).

Column: A stainless steel column 3.9 mm in inside diameter and 30 cm in length, packed with phenylsilylated silica gel for liquid chromatography (10 μ m in particle diameter).

Column temperature: A constant temperature of about 35°C.

Mobile phase: Dissolve 6.44 g of sodium sulfate decahydrate in diluted acetic acid (100) (1 in 100) to make 1000 mL, and add 250 mL of acetonitrile.

Flow rate: Adjust so that the retention time of etoposide is about 20 minutes.

System suitability—

System performance: Dissolve 10 mg of Etoposide in 2 mL of methanol, add 8 mL of the mobile phase, and mix well. Add 0.1 mL of diluted acetic acid (100) (1 in 25) and 0.1 mL of phenolphthalein TS, and add sodium hydroxide TS until the color of the solution changes to faintly red. After allowing to stand for 15 minutes, add 0.1 mL of diluted acetic acid (100) (1 in 25). When the procedure is run with 10 μ L of this solution under the above operating conditions, the resolution between the peak of etoposide and the peak having the relative retention time of about 1.3 to etoposide is not less than 3.

System repeatability: When the test is repeated 6 times with 50 μ L of the standard solution under the above operating conditions, the relative standard deviation of the ratio of the peak area of etoposide to that of the internal standard is not more than 1.0%.

Containers and storage Containers—Tight containers.

Storage—Light-resistant.

Famotidine

ファミチジン

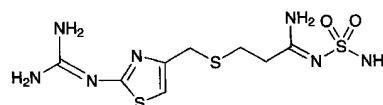

$\text{C}_8\text{H}_{15}\text{N}_7\text{O}_2\text{S}_3$: 337.45

N-Aminosulfonyl-3-[[2-(diaminomethyleneamino)-1,3-thiazol-4-yl]methylsulfanyl]propanimidamide [76824-35-6]

Famotidine, when dried, contains not less than 98.5% of famotidine ($\text{C}_8\text{H}_{15}\text{N}_7\text{O}_2\text{S}_3$).

Description Famotidine occurs as white to yellowish white crystals.

It is freely soluble in acetic acid (100), slightly soluble in ethanol (95), and very slightly soluble in water.

It dissolves in 0.5 mol/L hydrochloric acid TS.

It is gradually colored by light.

Melting point: about 164°C (with decomposition).

Identification (1) Determine the absorption spectrum of a solution of Famotidine in 0.05 mol/L potassium dihydrogen phosphate TS (1 in 50,000) as directed under Ultraviolet-visible Spectrophotometry <2.24>, and compare the spectrum with the Reference Spectrum: both spectra exhibit similar intensities of absorption at the same wavelengths.

(2) Determine the infrared absorption spectrum of Famotidine, previously dried, as directed in the potassium bromide disk method under Infrared Spectrophotometry <2.25>, and compare the spectrum with the Reference Spectrum: both spectra exhibit similar intensities of absorption at the same wave numbers.

Purity (1) Clarity and color of solution—Dissolve 0.5 g of Famotidine in 10 mL of 0.5 mol/L hydrochloric acid TS: the solution is clear and colorless to pale yellow.

(2) Heavy metals <1.07>—Proceed with 2.0 g of Famotidine according to Method 2, and perform the test. Prepare the control solution with 2.0 mL of Standard Lead Solution (not more than 10 ppm).

(3) Related substances—Dissolve 0.20 g of Famotidine in

10 mL of acetic acid (100), and use this solution as the sample solution. Pipet 1 mL of the sample solution, and add acetic acid (100) to make exactly 100 mL. Pipet 1 mL, 2 mL and 3 mL of this solution, add acetic acid (100) to make exactly 10 mL, respectively, and use these solutions as the standard solution (1), the standard solution (2) and the standard solution (3). Perform the test with these solutions as directed under Thin-layer Chromatography <2.03>. Spot 5 μ L each of the sample solution and standard solutions (1), (2) and (3) on a plate of silica gel (5 to 7 μ m) with fluorescent indicator for thin-layer chromatography, and dry in a stream of nitrogen. Develop the plate with a mixture of ethyl acetate, methanol, toluene and ammonia solution (28) (40:25:20:2) to a distance of about 8 cm, and air-dry the plate. Examine under ultraviolet light (main wavelength: 254 nm); the spots other than the principal spot and the spot of the starting point obtained from the sample solution are not more intense than the spot from the standard solution (3). Total intensity of the spots other than the principal spot and the spot of the starting point from the sample solution is not more than 0.5% calculated on the basis of intensities of the spots from the standard solution (1) and the standard solution (2).

Loss on drying <2.41> Not more than 0.5% (1 g, in vacuum, phosphorus (V) oxide, 80°C, 4 hours).

Residue on ignition <2.44> Not more than 0.1% (1 g).

Assay Weigh accurately about 0.3 g of Famotidine, previously dried, dissolve in 50 mL of acetic acid (100), and titrate <2.50> with 0.1 mol/L perchloric acid VS (potentiometric titration). Perform a blank determination in the same manner, and make any necessary correction.

Each mL of 0.1 mol/L perchloric acid VS
= 16.87 mg of $C_8H_{15}N_7O_2S_3$

Containers and storage Containers—Tight containers.
Storage—Light-resistant.

Famotidine Injection

ファミモチジン注射液

Famotidine Injection is an aqueous injection.

It contains not less than 92.0% and not more than 108.0% of the labeled amount of famotidine ($C_8H_{15}N_7O_2S_3$; 337.45).

Method of preparation Prepare as directed under Injections, with Famotidine.

Description Famotidine Injection is a colorless or light yellow, clear liquid.

Identification To an amount of Famotidine Injection, equivalent to 10 mg of Famotidine, add water to make 100 mL. Run 1 mL of this solution on a column prepared by filling about 1 cm inside diameter chromatography tube with about 0.4 g of 55 – 105 μ m octadecylsilanized silica gel for pretreatment. Wash the column with 15 mL of water, followed by elution with 5 mL of methanol. To the eluate add methanol to make 10 mL. Determine the absorption spectrum of this solution as directed under Ultraviolet-visible Spectrophotometry <2.24>: it exhibits a maximum between 285 nm and 289 nm.

Osmotic pressure ratio Being specified separately when the drug is granted approval based on the Law.

pH Being specified separately when the drug is granted approval based on the Law.

Purity Related substances—To an exact amount of Famotidine Injection, equivalent to 25 mg of Famotidine, add the mobile phase to make exactly 50 mL, and use this solution as the sample solution. Separately, weigh accurately about 10 mg of famotidine for assay, dissolve in methanol, and add methanol to make exactly 100 mL. Pipet 5 mL of this solution, add the mobile phase to make exactly 100 mL, and use this solution as the standard solution. Perform the test with exactly 20 μ L each of the sample solution and standard solution as directed under Liquid Chromatography <2.01> according to the following conditions. Determine the peak area of each solution by the automatic integration method, and calculate the amounts of the related substances by the following equation: the amounts of related substances, having the relative retention time about 1.3 and about 1.5 to famotidine are not more than 3.0% respectively, and the amount of other related substances except the above substances is not more than 0.5%, and the total amount of the related substances is not more than 5.0%.

$$\begin{aligned} \text{Amount (\%)} \text{ of related substance} &= M_S \times A_T/A_S \times 1/10 \\ \text{Total amount (\%)} \text{ of related substances} \\ &= M_S \times \Sigma A_T/A_S \times 1/10 \end{aligned}$$

M_S : Amount (mg) of famotidine for assay taken

A_S : Peak area of famotidine in the standard solution

A_T : Peak area of related substances in the sample solution

ΣA_T : Total peak area of the related substances in the sample solution

Operating conditions—

Detector, column and column temperature: Proceed as directed in the operating conditions in the Assay.

Mobile phase: Dissolve 1.74 g of sodium 1-pentane sulfonate in 900 mL of water, adjust to pH 4.0 with diluted acetic acid (100) (1 in 10), and add water to make 1000 mL. To 840 mL of this solution add 80 mL of methanol and 40 mL of acetonitrile.

Flow rate: Adjust so that the retention time of famotidine is about 17 minutes.

Time span of measurement: About 4 times as long as the retention time of famotidine, beginning after the solvent peak.

System suitability—

Test for required detectability: Pipet 5 mL of the standard solution, add the mobile phase to make exactly 50 mL. Confirm that the peak area of famotidine obtained with 20 μ L of this solution is equivalent to 8 to 12% of that with 20 μ L of the standard solution.

System performance: To 20 mg of famotidine for assay add 2 mL of a solution of methyl parahydroxybenzoate in acetonitrile (1 in 500), and add methanol to make 20 mL. To 5 mL of this solution add the mobile phase to make 50 mL. When the procedure is run with 10 μ L of this solution under the above operating conditions, famotidine and methyl parahydroxybenzoate are eluted in this order with the resolution between these peaks being not less than 19.

System repeatability: When the test is repeated 6 times with 20 μ L of the standard solution under the above operations conditions, the relative standard deviation of the peak area of famotidine is not more than 2.0%.

Bacterial endotoxins <4.01> Less than 15 EU/mg.

Extractable volume <6.05> It meets the requirement.

Foreign insoluble matter <6.06> Perform the test according

to Method I: it meets the requirement.

Insoluble particulate matter <6.07> It meets the requirement.

Sterility <4.06> Perform the test according to Membrane filtration method: it meets the requirement.

Assay To an exactly measured volume of Famotidine Injection, equivalent to about 25 mg of famotidine ($C_8H_{15}N_7O_2S_3$), add exactly 2.5 mL of the internal standard solution, and add the mobile phase to make 50 mL. Pipet 10 mL of this solution, add the mobile phase to make 50 mL, and use this solution as the sample solution. Separately, weigh accurately about 50 mg of famotidine for assay, previously dried in vacuum with phosphorus (V) oxide at 80°C for 4 hours, dissolve in methanol, add exactly 5 mL of the internal standard solution, and add methanol to make 50 mL. Pipet 5 mL of this solution, add the mobile phase to make 50 mL, and use this solution as the standard solution. Perform the test with 10 μ L each of the sample solution and standard solution as directed under Liquid Chromatography <2.01> according to the following conditions. Calculate the ratios, Q_T and Q_S of the peak area of famotidine to that of the internal standard.

$$\begin{aligned} &\text{Amount (mg) of famotidine (C}_8\text{H}_{15}\text{N}_7\text{O}_2\text{S}_3\text{)} \\ &= M_S \times Q_T / Q_S \times 1/2 \end{aligned}$$

M_S : Amount (mg) of famotidine for assay taken

Internal standard solution—A solution of methyl parahydroxybenzoate in acetonitrile (1 in 500).

Operating conditions—

Detector: An ultraviolet absorption photometer (Wavelength: 254 nm).

Column: A stainless steel column 4.6 mm in inside diameter and 15 cm in length, packed with octadecylsilanized silica gel for liquid chromatography (5 μ m in particle diameter).

Column temperature: A constant temperature of about 40°C.

Mobile phase: Dissolve 1.74 g of sodium 1-pentane sulfonate in 900 mL of water, adjust to pH 4.0 with diluted acetic acid (100) (1 in 10), and add water to make 1000 mL. To 750 mL of this solution add 200 mL of methanol and 50 mL of acetonitrile.

Flow rate: Adjust so that the retention time of famotidine is about 4 minutes.

System suitability—

System performance: When the procedure is run with 10 μ L of the standard solution under the above operating conditions, famotidine and the internal standard are eluted in this order with the resolution between these peaks being not less than 26.

System repeatability: When the test is repeated 5 times with 10 μ L of the standard solution under the above operating conditions, the relative standard deviation of the ratio of the peak area of famotidine to that of the internal standard is not more than 1.0%.

Containers and storage Containers—Hermetic containers.

Famotidine for Injection

注射用ファモチジン

Famotidine for Injection is a preparation for injection which is dissolved before use.

It contains not less than 94.0% and not more than 106.0% of the labeled amount of famotidine ($C_8H_{15}N_7O_2S_3$: 337.45).

Method of preparation Prepare as directed under Injection, with Famotidine.

Description Famotidine for Injection occurs as white, porous masses or powder.

Identification Dissolve an amount of Famotidine for Injection, equivalent to 0.01 g of Famotidine, in 50 mL of 0.05 mol/L potassium dihydrogen phosphate TS. To 5 mL of this solution add 0.05 mol/L potassium dihydrogen phosphate TS to make 50 mL, and determine the absorption spectrum of this solution as directed under Ultraviolet-visible Spectrophotometry <2.24>: it exhibits a maximum between 263 nm and 267 nm.

pH <2.54> Dissolve an amount of Famotidine for Injection, equivalent to 0.02 g of Famotidine, in 1 mL of water: the pH of this solution is between 4.9 and 5.5.

Purity (1) Clarity and color of solution—Dissolve an amount of Famotidine for Injection, equivalent to 0.02 g of Famotidine, in 1 mL of water: the solution is clear and colorless.

(2) Related substances—Take a number of Famotidine for Injection, equivalent to about 0.1 g of famotidine ($C_8H_{15}N_7O_2S_3$), dissolve each content in water, wash the inside of the container with water, combine the solutions of the contents with the washings, add water to the combined solution to make exactly 100 mL, and use this solution as the sample solution. Pipet 1 mL of the sample solution, add water to make exactly 100 mL, and use this solution as the standard solution. Perform the test with exactly 5 μ L each of the sample solution and standard solution as directed under Liquid Chromatography <2.01> according to the following conditions, and determine each peak area of these solutions by the automatic integration method: the total area of the peaks other than famotidine obtained from the sample solution is not larger than peak area of famotidine from the standard solution.

Operating conditions—

Detector, column, column temperature, mobile phase, and flow rate: Proceed as directed in the operating conditions in the Assay.

Time span of measurement: About 2 times as long as the retention time of famotidine, beginning after the solvent peak.

System suitability—

System performance: Proceed as directed in the system suitability in the Assay.

Test for required detectability: To exactly 2 mL of the standard solution add the water to make exactly 20 mL. Confirm that the peak area of famotidine obtained with 5 μ L of this solution is equivalent to 8 to 12% of that with 5 μ L of the standard solution.

System repeatability: When the test is repeated 6 times with 5 μ L of the standard solution under the above operating conditions, the relative standard deviation of the peak area of famotidine is not more than 2.0%.

Water <2.48> Not more than 1.5% (0.1 g, coulometric titration).

Bacterial endotoxins <4.01> Not more than 15 EU/mg.

Uniformity of dosage units <6.02> It meets the requirement of the Mass variation test.

Foreign insoluble matter <6.06> Perform the test according to Method 2: it meets the requirement.

Insoluble particulate matter <6.07> It meets the requirement.

Sterility <4.06> Perform the test according to the Membrane filtration method: it meets the requirement.

Assay Take a number of Famotidine for Injection, equivalent to about 0.1 g of famotidine ($C_8H_{15}N_7O_2S_3$), dissolve each content in water, wash the inside of each container with water, combine the solutions of the contents with the washings, add water to the combined solution to make exactly 100 mL. Pipet 5 mL of this solution, add exactly 5 mL of the internal standard solution, add the mobile phase to make 50 mL, and use this solution as the sample solution. Separately, weigh accurately about 50 mg of famotidine for assay, previously dried in vacuum with phosphorus (V) oxide at 80°C for 4 hours, dissolve in the mobile phase to make exactly 50 mL. Pipet 5 mL of this solution, add exactly 5 mL of the internal standard solution, add the mobile phase to make 50 mL, and use this solution as the standard solution. Perform the test with 5 μ L each of the sample solution and standard solution as directed under Liquid Chromatography <2.01> according to the following conditions, and calculate the ratios, Q_T and Q_S , of the peak area of famotidine to that of the internal standard.

$$\begin{aligned} & \text{Amount (mg) of famotidine (C}_8\text{H}_{15}\text{N}_7\text{O}_2\text{S}_3\text{)} \\ & = M_S \times Q_T/Q_S \times 2 \end{aligned}$$

M_S : Amount (mg) of famotidine for assay taken

Internal standard solution—To 5 mL of a solution of methyl parahydroxybenzoate in methanol (1 in 500) add water to make 50 mL.

Operating conditions—

Detector: An ultraviolet absorption photometer (wavelength: 254 nm).

Column: A stainless steel column 4.6 mm in inside diameter and 15 cm in length, packed with octadecylsilanized silica gel for liquid chromatography (5 μ m in particle diameter).

Column temperature: A constant temperature of about 25°C.

Mobile phase: Dissolve 2 g of sodium 1-heptane sulfonate in 900 mL of water, adjust to pH 3.0 with acetic acid (100), and add water to make 1000 mL. To this solution add 240 mL of acetonitrile and 40 mL of methanol.

Flow rate: Adjust so that the retention time of famotidine is about 6 minutes.

System suitability—

System performance: When the procedure is run with 5 μ L of the standard solution under the above operating conditions, famotidine and the internal standard are eluted in this order with the resolution between these peaks being not less than 11.

System repeatability: When the test is repeated 6 times with 5 μ L of the standard solution under the above operating conditions, the relative standard deviation of the ratios of the peak area of famotidine to that of the internal standard is not more than 1.0%.

Containers and storage Containers—Hermetic containers.

Famotidine Powder

ファミチジン散

Famotidine Powder contains not less than 94.0% and not more than 106.0% of the labeled amount of famotidine ($C_8H_{15}N_7O_2S_3$; 337.45).

Method of preparation Prepare as directed under Granules or Powders, with Famotidine.

Identification Weigh a portion of Famotidine Powder, equivalent to 0.01 g of Famotidine, add 50 mL of 0.05 mol/L potassium dihydrogen phosphate TS, shake well, and centrifuge. To 5 mL of the supernatant liquid add 0.05 mol/L potassium dihydrogen phosphate TS to make 50 mL, and determine the absorption spectrum of this solution as directed under Ultraviolet-visible Spectrophotometry <2.24>: it exhibits a maximum between 263 nm and 267 nm.

Uniformity of dosage units <6.02> Perform the test according to the following method: Famotidine Powder in single-dose packages meets the requirement of the Content uniformity test.

Take out the total content of 1 package of Famotidine Powder, add 10 mL of water per 10 mg of famotidine ($C_8H_{15}N_7O_2S_3$), shake well, add 10 mL of methanol, shake well, add methanol to make exactly V mL so that each mL contains about 0.4 mg of famotidine ($C_8H_{15}N_7O_2S_3$), and centrifuge. Pipet 5 mL of the supernatant liquid, add exactly 2 mL of the internal standard solution, add the mobile phase to make 20 mL, and use this solution as the sample solution. Proceed as directed in the Assay.

$$\begin{aligned} & \text{Amount (mg) of famotidine (C}_8\text{H}_{15}\text{N}_7\text{O}_2\text{S}_3\text{)} \\ & = M_S \times Q_T/Q_S \times V/250 \end{aligned}$$

M_S : Amount (mg) of famotidine for assay taken

Internal standard solution—To 5 mL of a solution of methyl parahydroxybenzoate in methanol (1 in 500) add water to make 50 mL.

Dissolution <6.10> When the test is performed at 50 revolutions per minute according to the Paddle method, using 900 mL of 0.05 mol/L acetic acid-sodium acetate buffer solution (pH 4.0) as the dissolution medium, the dissolution rates in 15 minutes of a 20-mg/g powder and a 100-mg/g powder are not less than 80% and not less than 85%, respectively.

Start the test with an accurately weighed amount of Famotidine Powder, equivalent to about 20 mg of famotidine ($C_8H_{15}N_7O_2S_3$), withdraw not less than 20 mL of the medium at the specified minute after starting the test, and filter through a membrane filter with a pore size not exceeding 0.5 μ m. Discard not less than 10 mL of the first filtrate, and use the subsequent filtrate as the sample solution. Separately, weigh accurately about 40 mg of famotidine for assay, previously dried in vacuum on phosphorus (V) oxide at 80°C for 4 hours, dissolve in the dissolution medium to make exactly 100 mL. Pipet 5 mL of this solution, add the dissolution medium to make exactly 100 mL, and use this solution as the standard solution. Determine the absorbances, A_T and A_S , of the sample solution and standard solution at 266 nm as directed under Ultraviolet-visible Spectrophotometry <2.24>.

$$\begin{aligned} & \text{Dissolution rate (\%)} \text{ with respect to the labeled amount} \\ & \text{of famotidine (C}_8\text{H}_{15}\text{N}_7\text{O}_2\text{S}_3\text{)} \\ & = M_S/M_T \times A_T/A_S \times 1/C \times 45 \end{aligned}$$

M_S : Amount (mg) of famotidine for assay taken

M_T : Amount (g) of Famotidine Powder taken

C: Labeled amount (mg) of famotidine ($C_8H_{15}N_7O_2S_3$) in 1 g

Assay Weigh accurately a portion of Famotidine Powder, equivalent to about 20 mg of famotidine ($C_8H_{15}N_7O_2S_3$), add 20 mL of water, and shake well. Add 20 mL of methanol, then shake well, add methanol to make exactly 50 mL, and centrifuge. Pipet 5 mL of the supernatant liquid, add exactly 2 mL of the internal standard solution, add the mobile phase to make 20 mL, and use this solution as the sample solution. Separately, weigh accurately about 0.1 g of famotidine for assay, previously dried in vacuum with phosphorus (V) oxide at 80°C for 4 hours, dissolve in methanol to make exactly 50 mL. Pipet 10 mL of this solution, and add methanol to make exactly 50 mL. Pipet 5 mL of this solution, add exactly 2 mL of the internal standard solution, add the mobile phase to make 20 mL, and use this solution as the standard solution. Perform the test with 5 μ L each of the sample solution and standard solution as directed under Liquid Chromatography <2.01> according to the following conditions, and calculate the ratios, Q_T and Q_S , of the peak area of famotidine to that of the internal standard.

$$\begin{aligned} &\text{Amount (mg) of famotidine (C}_8\text{H}_{15}\text{N}_7\text{O}_2\text{S}_3\text{)} \\ &= M_S \times Q_T/Q_S \times 1/5 \end{aligned}$$

M_S : Amount (mg) of famotidine for assay taken

Internal standard solution—To 5 mL of a solution of methyl parahydroxybenzoate in methanol (1 in 500) add water to make 50 mL.

Operating conditions—

Detector: An ultraviolet absorption photometer (wavelength: 254 nm).

Column: A stainless steel column 4.6 mm in inside diameter and 15 cm in length, packed with octadecylsilanized silica gel for liquid chromatography (5 μ m in particle diameter).

Column temperature: A constant temperature of about 25°C.

Mobile phase: Dissolve 2 g of sodium 1-heptane sulfonate in 900 mL of water, adjust to pH 3.0 with acetic acid (100), and add water to make 1000 mL. To this solution add 240 mL of acetonitrile and 40 mL of methanol.

Flow rate: Adjust so that the retention time of famotidine is about 6 minutes.

System suitability—

System performance: When the procedure is run with 5 μ L of the standard solution under the above operating conditions, famotidine and the internal standard are eluted in this order with the resolution between these peaks being not less than 11.

System repeatability: When the test is repeated 6 times with 5 μ L of the standard solution under the above operating conditions, the relative standard deviation of the ratios of the peak area of famotidine to that of the internal standard is not more than 1.0%.

Containers and storage Containers—Tight containers.

Famotidine Tablets

ファモチジン錠

Famotidine Tablets contain not less than 94.0% and not more than 106.0% of the labeled amount of famotidine ($C_8H_{15}N_7O_2S_3$; 337.45).

Method of preparation Prepare as directed under Tablets, with Famotidine.

Identification Weigh a portion of powdered Famotidine Tablets, equivalent to 0.01 g of Famotidine, add 50 mL of 0.05 mol/L potassium dihydrogen phosphate TS, shake well, and centrifuge. To 5 mL of the supernatant liquid add 0.05 mol/L potassium dihydrogen phosphate TS to make 50 mL, and determine the absorption spectrum of this solution as directed under Ultraviolet-visible Spectrophotometry <2.24>: it exhibits a maximum between 263 nm and 267 nm.

Uniformity of dosage units <6.02> Perform the test according to the following method: it meets the requirement of the Content uniformity test.

To 1 tablet of Famotidine Tablets add 2 mL of water, shake to disintegrate, then add a suitable amount of methanol, and shake well. Add methanol to make exactly V mL of a solution containing about 0.2 mg of famotidine ($C_8H_{15}N_7O_2S_3$) per mL, and centrifuge. Pipet 10 mL of the supernatant liquid, add exactly 2 mL of the internal standard solution, add the mobile phase to make 20 mL, and use this solution as the sample solution. Separately, weigh accurately about 0.1 g of famotidine for assay, previously dried in vacuum with phosphorus (V) oxide at 80°C for 4 hours, dissolve in methanol to make exactly 100 mL. Pipet 10 mL of this solution, and add methanol to make exactly 50 mL. Pipet 10 mL of this solution, add exactly 2 mL of the internal standard solution, add the mobile phase to make 20 mL, and use this solution as the standard solution. Perform the test with 5 μ L each of the sample solution and standard solution as directed under Liquid Chromatography <2.01> according to the operating conditions described in the Assay, and calculate the ratios, Q_T and Q_S , of the peak area of famotidine to that of the internal standard.

$$\begin{aligned} &\text{Amount (mg) of famotidine (C}_8\text{H}_{15}\text{N}_7\text{O}_2\text{S}_3\text{)} \\ &= M_S \times Q_T/Q_S \times V/500 \end{aligned}$$

M_S : Amount (mg) of famotidine for assay taken

Internal standard solution—To 5 mL of a solution of methyl parahydroxybenzoate in methanol (1 in 500) add water to make 50 mL.

Dissolution Being specified separately when the drug is granted approval based on the Law.

Assay Take a number of Famotidine Tablets, equivalent to 0.2 g of famotidine ($C_8H_{15}N_7O_2S_3$), add 50 mL of water, and disintegrate by shaking well. Add 100 mL of methanol, then shake well, add methanol to make exactly 200 mL, and centrifuge. Pipet 5 mL of the supernatant liquid, add exactly 5 mL of the internal standard solution, add the mobile phase to make 50 mL, and use this solution as the sample solution. Separately, weigh accurately about 0.1 g of famotidine for assay, previously dried in vacuum with phosphorus (V) oxide at 80°C for 4 hours, dissolve in methanol to make exactly 100 mL. Pipet 5 mL of this solution, add exactly 5 mL of the internal standard solution, add the mobile phase to make 50 mL, and use this solution as the standard solution. Perform

the test with 5 μL each of the sample solution and standard solution as directed under Liquid Chromatography <2.01> according to the following conditions, and calculate the ratios, Q_T and Q_S , of the peak area of famotidine to that of the internal standard.

$$\begin{aligned} \text{Amount (mg) of famotidine (C}_8\text{H}_{15}\text{N}_7\text{O}_2\text{S}_3) \\ = M_S \times Q_T/Q_S \times 2 \end{aligned}$$

M_S : Amount (mg) of famotidine for assay taken

Internal standard solution—To 5 mL of a solution of methyl parahydroxybenzoate in methanol (1 in 500) add water to make 50 mL.

Operating conditions—

Detector: An ultraviolet absorption photometer (wavelength: 254 nm).

Column: A stainless steel column 4.6 mm in inside diameter and 15 cm in length, packed with octadecylsilanized silica gel for liquid chromatography (5 μm in particle diameter).

Column temperature: A constant temperature of about 25°C.

Mobile phase: Dissolve 2 g of sodium 1-heptane sulfonate in 900 mL of water, adjust to pH 3.0 with acetic acid (100), and add water to make 1000 mL. To this solution add 240 mL of acetonitrile and 40 mL of methanol.

Flow rate: Adjust so that the retention time of famotidine is about 6 minutes.

System suitability—

System performance: When the procedure is run with 5 μL of the standard solution under the above operating conditions, famotidine and the internal standard are eluted in this order with the resolution between these peaks being not less than 11.

System repeatability: When the test is repeated 6 times with 5 μL of the standard solution under the above operating conditions, the relative standard deviation of the ratios of the peak area of famotidine to that of the internal standard is not more than 1.0%.

Containers and storage Containers—Tight containers.

Faropenem Sodium Hydrate

ファロペネムナトリウム水和物

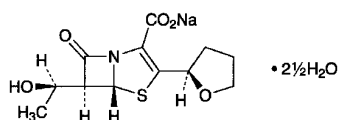

$\text{C}_{12}\text{H}_{14}\text{NNaO}_5\text{S} \cdot 2\frac{1}{2}\text{H}_2\text{O}$: 352.34

Monosodium (5*R*,6*S*)-6-[(1*R*)-1-hydroxyethyl]-7-oxo-3-[(2*R*)-tetrahydrofuran-2-yl]-4-thia-1-azabicyclo[3.2.0]hept-2-ene-2-carboxylate hemipentahydrate
[122547-49-3, anhydride]

Faropenem Sodium Hydrate contains not less than 870 μg (potency) and not more than 943 μg (potency) per mg, calculated on the anhydrous basis. The potency of Faropenem Sodium Hydrate is expressed as mass (potency) of faropenem ($\text{C}_{12}\text{H}_{15}\text{NO}_5\text{S}$: 285.32).

Description Faropenem Sodium Hydrate occurs as white to light yellow, crystals or crystalline powder.

It is freely soluble in water and in methanol, slightly soluble in ethanol (95), and practically insoluble in diethyl ether.

Identification (1) Dissolve 5 mg of Faropenem Sodium

Hydrate in 1 mL of hydroxylammonium chloride-ethanol TS, allow to stand for 3 minutes, add 1 mL of acidic ammonium iron (III) sulfate TS, and shake: a red-brown to brown color develops.

(2) Determine the absorption spectra of solutions of Faropenem Sodium Hydrate and Faropenem Sodium RS (1 in 20,000) as directed under Ultraviolet-visible Spectrophotometry <2.24>, and compare the spectra: both spectra exhibit similar intensities of absorption at the same wavelengths.

(3) Determine the infrared absorption spectra of Faropenem Sodium Hydrate and Faropenem Sodium RS as directed in the potassium bromide disk method under Infrared Spectrophotometry <2.25>, and compare the spectra: both spectra exhibit similar intensities of absorption at the same wave numbers.

Optical rotation <2.49> $[\alpha]_D^{20}$: +145 – +150° (0.5 g calculated as the anhydrous basis, water, 50 mL, 100 mm).

Purity (1) Heavy metals <1.07>—Proceed with 2.0 g of Faropenem Sodium Hydrate according to Method 4, and perform the test. Prepare the control solution with 2.0 mL of Standard Lead Solution (not more than 10 ppm).

(2) Related substances—Dissolve a quantity of Faropenem Sodium Hydrate equivalent to 0.10 g (potency) in 200 mL of water, and use this solution as the sample solution. Pipet 2 mL of the sample solution, add water to make exactly 200 mL, and use this solution as the standard solution. Perform the test with exactly 20 μL each of the sample solution and standard solution as directed under Liquid Chromatography <2.01> according to the following conditions, and determine each peak area by the automatic integration method: the peak area of the epimer, having the relative retention time of about 1.1 to faropenem, obtained from the sample solution is not larger than 3/10 times the peak area of faropenem from the standard solution, and the total area of the peaks other than faropenem from the sample solution is not larger than 1/2 times the peak area of faropenem from the standard solution.

Operating conditions—

Column, column temperature, mobile phase, and flow rate: Proceed as directed in the operating conditions in the Assay.

Detector: An ultraviolet absorption photometer (wavelength: 240 nm).

Time span of measurement: About 6 times as long as the retention time of faropenem, beginning after the solvent peak.

System suitability—

Test for required detectability: To exactly 2 mL of the standard solution add water to make exactly 20 mL. Confirm that the peak area of faropenem obtained with 20 μL of this solution is equivalent to 7 to 13% of that with 20 μL of the standard solution.

System performance: When the procedure is run with 20 μL of the standard solution obtained in the Assay under the above operating conditions, the internal standard and faropenem are eluted in this order with the resolution between these peaks being not less than 1.5.

System repeatability: When the test is repeated 6 times with 20 μL of the standard solution under the above operating conditions, the relative standard deviation of the peak area of faropenem is not more than 2.0%.

Water <2.48> Not less than 12.6% and not more than 13.1% (20 mg, coulometric titration).

Assay Weigh accurately an amount of Faropenem Sodium

Hydrate and Faropenem Sodium RS, equivalent to about 25 mg (potency), add exactly 10 mL each of the internal standard solution, add water to make 50 mL, and use these solutions as the sample solution and the standard solution, respectively. Perform the test with 20 μ L of the sample solution and standard solution as directed under Liquid Chromatography <2.01> according to the following conditions, and calculate the ratios, Q_T and Q_S , of the peak area of faropenem to that of the internal standard.

$$\begin{aligned} \text{Amount } [\mu\text{g (potency)}] \text{ of faropenem (C}_{12}\text{H}_{15}\text{NO}_5\text{S)} \\ = M_S \times Q_T / Q_S \times 1000 \end{aligned}$$

M_S : amount [mg (potency)] of Faropenem Sodium RS taken

Internal standard solution—Dissolve 0.5 g of *m*-hydroxyacetophenone in 20 mL of acetonitrile, and add water to make 200 mL.

Operating conditions—

Detector: An ultraviolet absorption photometer (wavelength: 305 nm).

Column: A stainless steel column 4.6 mm in inside diameter and 25 cm in length, packed with octadecylsilanized silica gel for liquid chromatography (5 μ m in particle diameter).

Column temperature: A constant temperature of about 40°C.

Mobile phase: Dissolve 4.8 g of potassium dihydrogen phosphate, 5.4 g of disodium hydrogen phosphate dodecahydrate and 1.0 g of tetra *n*-butyl ammonium bromide in water to make 1000 mL. To 870 mL of this solution add 130 mL of acetonitrile.

Flow rate: Adjust so that the retention time of faropenem is about 11 minutes.

System suitability—

System performance: When the procedure is run with 20 μ L of the standard solution under the above operating conditions, the internal standard and faropenem are eluted in this order with the resolution between these peaks being not less than 1.5.

System repeatability: When the test is repeated 6 times with 20 μ L of the standard solution under the above operating conditions, the relative standard deviation of the ratios of the peak area of faropenem to that of the internal standard is not more than 1.0%.

Containers and storage Containers—Tight containers.

Faropenem Sodium for Syrup

シロップ用ファロペネムナトリウム

Faropenem Sodium for Syrup is a preparation for syrup, which is dissolved before use.

It contains not less than 93.0% and not more than 106.0% of the labeled potency of faropenem (C₁₂H₁₅NO₅S: 285.32).

Method of preparation Prepare as directed under Preparations for Syrups, with Faropenem Sodium Hydrate.

Identification Dissolve an amount of powdered Faropenem Sodium for Syrup, equivalent to 25 mg (potency) of Faropenem Sodium Hydrate, in water to make 50 mL. To 5 mL of this solution add water to make 50 mL, filter, if necessary, and determine the absorption spectrum of the solution so obtained as directed under Ultraviolet-visible Spectrophotometry <2.24>: it exhibits maxima between 254 nm and 258

nm, and between 304 nm and 308 nm.

Purity Related substances—Powder Faropenem Sodium for Syrup, if necessary. To a part of the powder, equivalent to about 25 mg (potency) of Faropenem Sodium Hydrate, add about 10 mL of water, shake well, then add water to make exactly 50 mL, and filter. Discard the first 10 mL of the filtrate, and use the subsequent filtrate as the sample solution. Pipet 2 mL of the sample solution, add water to make exactly 200 mL, and use this solution as the standard solution. Perform the test with exactly 20 μ L each of the sample solution and standard solution as directed under Liquid Chromatography <2.01> according to the following conditions, and determine each peak area of both solutions by the automatic integration method: the area of the peak of cleaved derivative, having the relative retention time of about 0.71 to faropenem, obtained from the sample solution is not larger than 1.5 times the peak area of faropenem from the standard solution, and the total area of the peaks other than faropenem from the sample solution is not larger than 2 times the peak area of faropenem from the standard solution. For the area of the peak, having the relative retention time of about 0.71 to faropenem, multiply its correction factor 0.37.

Operating conditions—

Detector: An ultraviolet absorption photometer (wavelength: 240 nm).

Column: A stainless steel column 4 mm in inside diameter and 25 cm in length, packed with octadecylsilanized silica gel for liquid chromatography (5 μ m in particle diameter).

Column temperature: A constant temperature of about 40°C.

Mobile phase A: Dissolve 6.12 g of potassium dihydrogen phosphate, 1.79 g of disodium hydrogen phosphate dodecahydrate and 1.61 g of tetra *n*-butylammonium bromide in water to make 1000 mL.

Mobile phase B: A mixture of the mobile phase A and acetonitrile (1:1).

Flowing of mobile phase: Control the gradient by mixing the mobile phases A and B as directed in the following table.

Time after injection of sample (min)	Mobile phase A (vol%)	Mobile phase B (vol%)
0 - 54	84 → 30	16 → 70

Flow rate: 1.5 mL per minute.

Time span of measurement: 2.5 times as long as the retention time of faropenem, beginning after the solvent peak.

System suitability—

Test for required detectability: To exactly 2 mL of the standard solution add water to make exactly 20 mL. Confirm that the peak area of faropenem obtained with 20 μ L of this solution is equivalent to 7 to 13% of that with 20 μ L of the standard solution.

System performance: When the procedure is run with 20 μ L of the standard solution obtained in the Assay under the above operating conditions, the internal standard and faropenem are eluted in this order with the resolution between these peaks being not less than 11.

System repeatability: When the test is repeated 6 times with 20 μ L of the standard solution under the above operating conditions, the relative standard deviation of the peak area of faropenem is not more than 3.0%.

Water <2.48> Not less than 1.5% and not more than 2.1% (80 mg, coulometric titration).

Uniformity of dosage units <6.02> Faropenem Sodium for Syrup in single-dose packages meet the requirement of the Mass variation test.

Assay Powder, if necessary, and weigh accurately an amount of Faropenem Sodium for Syrup, equivalent to about 25 mg (potency) of faropenem ($C_{12}H_{15}NO_5S$), add exactly 10 mL of the internal standard solution and a suitable amount of water, shake well, and add water to make 50 mL. Filter, discard the first 10 mL of the filtrate, and use the subsequent filtrate as the sample solution. Separately, weigh accurately about 25 mg (potency) of Faropenem Sodium RS, add exactly 10 mL of the internal standard solution and water to make 50 mL, and use this solution as the standard solution. Proceed as directed in the Assay under Faropenem Sodium Hydrate.

$$\begin{aligned} &\text{Amount [mg (potency)] of faropenem } (C_{12}H_{15}NO_5S) \\ &= M_S \times Q_T / Q_S \end{aligned}$$

M_S : Amount [mg (potency)] of Faropenem Sodium RS taken

Internal standard solution—Dissolve 0.5 g of *m*-hydroxyacetophenone in 20 mL of acetonitrile, and add water to make 200 mL.

Containers and storage Containers—Tight containers.
Storage—Light-resistant.

Faropenem Sodium Tablets

ファロペネムナトリウム錠

Faropenem Sodium Tablets contain not less than 94.0% and not more than 106.0% of the labeled potency of faropenem ($C_{12}H_{15}NO_5S$; 285.32).

Method of preparation Prepare as directed under Tablets, with Faropenem Sodium Hydrate.

Identification To powdered Faropenem Sodium Tablets, equivalent to 70 mg (potency) of Faropenem Sodium Hydrate, add water to make 100 mL. To 5 mL of this solution add water to make 100 mL, filter, if necessary, and determine the absorption spectrum of this solution as directed under Ultraviolet-visible Spectrophotometry <2.24>: it exhibits maxima between 254 nm and 258 nm and between 304 nm and 308 nm.

Purity Related substances—Powder not less than 5 Faropenem Sodium Tablets. To a part of the powder, equivalent to about 25 mg (potency) of Faropenem Sodium Hydrate, add about 10 mL of water, shake well, then add water to make exactly 50 mL, and filter. Discard the first 10 mL of the filtrate, and use the subsequent filtrate as the sample solution. Pipet 2 mL of the sample solution, add water to make exactly 200 mL, and use this solution as the standard solution. Perform the test with exactly 20 μ L each of the sample solution and standard solution as directed under Liquid Chromatography <2.01> according to the following conditions, and determine each peak area of both solutions by the automatic integration method: the area of the peak of cleaved derivative, having the relative retention time of about 0.71 to faropenem, obtained from the sample solution is not larger than 1.5 times the peak area of faropenem from the standard solution, and the total area of the peaks other than faropenem from the sample solution is not larger than 2.5 times the peak area of faropenem from the standard so-

lution. For the area of the peak, having the relative retention time of about 0.71 to faropenem, multiply its correction factor 0.37.

Operating conditions—

Detector: An ultraviolet absorption photometer (wavelength: 240 nm).

Column: A stainless steel column 4 mm in inside diameter and 25 cm in length, packed with octadecylsilanized silica gel for liquid chromatography (5 μ m in particle diameter).

Column temperature: A constant temperature of about 40°C.

Mobile phase A: Dissolve 6.12 g of potassium dihydrogen phosphate, 1.79 g of disodium hydrogen phosphate dodecahydrate and 1.61 g of tetra *n*-butylammonium bromide in water to make 1000 mL.

Mobile phase B: A mixture of the mobile phase A and acetonitrile (1:1).

Flowing of mobile phase: Control the gradient by mixing the mobile phases A and B as directed in the following table.

Time after injection of sample (min)	Mobile phase A (vol%)	Mobile phase B (vol%)
0 – 54	84 → 30	16 → 70

Flow rate: 1.5 mL per minute.

Time span of measurement: About 2.5 times as long as the retention time of faropenem, beginning after the solvent peak.

System suitability—

Test for required detectability: To exactly 2 mL of the standard solution add water to make exactly 20 mL. Confirm that the peak area of faropenem obtained with 20 μ L of this solution is equivalent to 7 to 13% of that with 20 μ L of the standard solution.

System performance: When the procedure is run with 20 μ L of the standard solution obtained in the Assay under the above operating conditions, the internal standard and faropenem are eluted in this order with the resolution between these peaks being not less than 11.

System repeatability: When the test is repeated 6 times with 20 μ L of the standard solution under the above operating conditions, the relative standard deviation of the peak area of faropenem is not more than 3.0%.

Uniformity of dosage units <6.02> Perform the Mass variation test, or the Content uniformity test according to the following method: it meets the requirement.

To 1 tablet of Faropenem Sodium Tablets add 130 mL of water, shake vigorously until the tablets are disintegrated, and add water to make exactly *V* mL so that each mL contains about 1 mg (potency) of Faropenem Sodium Hydrate. Pipet 5 mL of this solution, add water to make exactly 100 mL, and filter. Discard the first 10 mL of the filtrate, and use the subsequent filtrate as the sample solution. Separately, weigh accurately about 25 mg (potency) of Faropenem Sodium RS, and dissolve in water to make exactly 50 mL. Pipet 10 mL of this solution, add water to make exactly 100 mL, and use this solution as the standard solution. Determine the absorbances, A_{T275} , A_{T305} , A_{T354} , A_{S275} , A_{S305} and A_{S354} , of the sample solution and standard solution at 275 nm, 305 nm and 354 nm as directed under Ultraviolet-visible Spectrophotometry <2.24>, and calculate A_T and A_S , using the following equations.

$$A_T = A_{T305} - (49 \times A_{T275} + 30 \times A_{T354}) / 79$$

$$A_S = A_{S305} - (49 \times A_{S275} + 30 \times A_{S354}) / 79$$

$$\begin{aligned} & \text{Amount [mg (potency)] of faropenem (C}_{12}\text{H}_{15}\text{NO}_5\text{S)} \\ & = M_S \times A_T/A_S \times V/25 \end{aligned}$$

M_S : Amount [mg (potency)] of Faropenem Sodium RS taken

Dissolution <6.10> When the test is performed at 50 revolutions per minute according to the Paddle method, using 900 mL of water as the dissolution medium, the dissolution rate in 30 minutes of Faropenem Sodium Tablets is not less than 85%.

Start the test with 1 tablet of Faropenem Sodium Tablets, withdraw not less than 20 mL of the medium at the specified minute after starting the test, and filter through a membrane filter with a pore size not exceeding 0.45 μm . Discard not less than 10 mL of the first filtrate, pipet V mL of the subsequent filtrate, add water to make exactly V' mL so that each mL contains about 56 μg (potency) of Faropenem Sodium Hydrate, and use this solution as the sample solution. Separately, weigh accurately an amount of Faropenem Sodium RS, equivalent to about 18 mg (potency), and dissolve in water to make exactly 100 mL. Pipet 5 mL of this solution, add water to make exactly 20 mL, and use this solution as the standard solution. Perform the test with the sample solution and standard solution as directed under Ultraviolet-visible Spectrophotometry <2.24>, and determine the absorbances, A_T and A_S , at 306 nm.

$$\begin{aligned} & \text{Dissolution rate (\%)} \text{ with respect to the labeled amount} \\ & \text{of faropenem (C}_{12}\text{H}_{15}\text{NO}_5\text{S)} \\ & = M_S \times A_T/A_S \times V'/V \times 1/C \times 225 \end{aligned}$$

M_S : Amount [mg (potency)] of Faropenem Sodium RS taken

C : Labeled amount [mg (potency)] of faropenem (C₁₂H₁₅NO₅S) in 1 tablet

Assay Weigh accurately the mass of not less than 5 Faropenem Sodium Tablets, and powder. Weigh accurately a portion of the powder, equivalent to about 25 mg (potency) of faropenem (C₁₂H₁₅NO₅S), add exactly 10 mL of the internal standard solution, shake well, and add water to make 50 mL. Filter, discard the first 10 mL of the filtrate, and use the subsequent filtrate as the sample solution. Separately, weigh accurately about 25 mg (potency) of Faropenem Sodium RS, add exactly 10 mL of the internal standard solution and water to make 50 mL, and use this solution as the standard solution. Proceed as directed in the Assay under Faropenem Sodium Hydrate.

$$\begin{aligned} & \text{Amount [mg (potency)] of faropenem (C}_{12}\text{H}_{15}\text{NO}_5\text{S)} \\ & = M_S \times Q_T/Q_S \end{aligned}$$

M_S : Amount [mg (potency)] of Faropenem Sodium RS taken

Internal standard solution—Dissolve 0.5 g of *m*-hydroxyacetophenone in 20 mL of acetonitrile, and add water to make 200 mL.

Containers and storage Containers—Tight containers.

Felbinac

フェルビナク

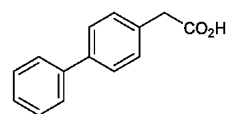

C₁₄H₁₂O₂: 212.24
Biphenyl-4-ylacetic acid
[5728-52-9]

Felbinac, when dried, contains not less than 98.5% and not more than 101.0% of felbinac (C₁₄H₁₂O₂).

Description Felbinac occurs as white to pale yellow-white, crystals or crystalline powder.

It is soluble in methanol and in acetone, sparingly soluble in ethanol (95), and practically insoluble in water.

Identification (1) Determine the absorption spectrum of a solution of Felbinac in ethanol (95) (1 in 200,000) as directed under Ultraviolet-visible Spectrophotometry <2.24>, and compare the spectrum with the Reference Spectrum: both spectra exhibit similar intensities of absorption at the same wavelengths.

(2) Determine the infrared absorption spectrum of Felbinac as directed in the potassium bromide disc method under Infrared Spectrophotometry <2.25>, and compare the spectrum with the Reference Spectrum: both spectra exhibit similar intensities of absorption at the same wave numbers.

Melting point <2.60> 163 – 166°C

Purity (1) Chloride <1.03>—Dissolve 1.0 g of Felbinac in 40 mL of acetone, add 6 mL of dilute nitric acid and water to make 50 mL. Perform the test using this solution as the test solution. Prepare the control solution by combining 0.30 mL of 0.01 mol/L hydrochloric acid VS, 40 mL of acetone and 6 mL of dilute nitric acid, and add water to make 50 mL (not more than 0.011%).

(2) Heavy metals <1.07>—Proceed with 1.0 g of Felbinac according to Method 2, and perform the test. Prepare the control solution with 1.0 mL of Standard Lead Solution (not more than 10 ppm).

(3) Related substances—Dissolve 0.10 g of Felbinac in 10 mL of acetone, and use this solution as the sample solution. Pipet 2 mL of the sample solution, and add acetone to make exactly 100 mL. Pipet 5 mL of the sample solution, add acetone to make exactly 50 mL, and use this solution as the standard solution. Perform the test with these solutions as directed under Thin-layer Chromatography <2.03>. Spot 10 μL each of the sample solution and standard solution on a plate of silica gel with fluorescent indicator for thin-layer chromatography. Develop the plate with a mixture of heptane, acetone, and acetic acid (100) (50:25:1) to a distance of about 12 cm, and air-dry the plate. Examine the plate under ultraviolet light (main wavelength: 254 nm): spots other than the principal spot obtained from the sample solution are not more intense than the spot from the standard solution.

Loss on drying <2.41> Not more than 0.3% (1 g, 105°C, 3 hours).

Residue on ignition <2.44> Not more than 0.1% (1 g).

Assay Weigh accurately about 0.5 g of Felbinac, previously dried, dissolve in 50 mL of methanol, add 15 mL of water, and titrate <2.50> with 0.1 mol/L sodium hydroxide VS

(potentiometric titration). Perform a blank determination in the same manner, and make any necessary correction.

Each mL of 0.1 mol/L sodium hydroxide VS
= 21.22 mg of $C_{14}H_{12}O_2$

Containers and storage Containers—Tight containers.

Felbinac Cataplasm

フェルビナクパッチ

Felbinac Cataplasm contains not less than 90.0% and not more than 110.0% of the labeled amount of felbinac ($C_{14}H_{12}O_2$: 212.24).

Method of preparation Prepare as directed under Cataplasms/Gel Patches, with Felbinac.

Identification Weigh a quantity of Felbinac Cataplasm, equivalent to 10 mg of Felbinac, cut into minute pieces, add 20 mL of methanol, shake for 30 minutes, filter, and use the filtrate as the sample solution. Separately, dissolve 1 mg of felbinac for assay in 2 mL of methanol, and use this solution as the standard solution. Perform the test with these solutions as directed under Thin-layer Chromatography <2.03>. Spot 10 μ L each of the sample solution and standard solution on a plate of silica gel with fluorescent indicator for thin-layer chromatography. Develop the plate with a mixture of hexane, acetone and acetic acid (100) (50:25:1) to a distance of about 10 cm, and air-dry the plate. Examine under ultraviolet light (main wavelength: 254 nm): the R_f value of the principal spot obtained from the sample solution and the spot from the standard solution is the same.

pH Being specified separately when the drug is granted approval based on the Law.

Adhesiveness Being specified separately when the drug is granted approval based on the Law.

Drug release Being specified separately when the drug is granted approval based on the Law.

Assay Take exactly a quantity of Felbinac Cataplasm, equivalent to 70 mg of felbinac ($C_{14}H_{12}O_2$), cut into minute pieces, add 150 mL of methanol, and heat under a reflux condenser. After cooling, separate the extraction liquid, add 20 mL of water to the residue, heat in a water bath at 75°C for 10 minutes, then add 150 mL of methanol, and heat under a reflux condenser. After cooling, separate the extraction liquid, add 150 mL of methanol to the residue, and heat under a reflux condenser. After cooling, separate the extraction liquid, wash the residue and vessels with a small amount of methanol, combine the extraction liquids and washings, and add methanol to make exactly 500 mL. Pipet 6 mL of this solution, add exactly 3 mL of the internal standard solution, add methanol to make 50 mL, and use this solution as the sample solution. Separately, weigh accurately about 35 mg of felbinac for assay, previously dried at 105°C for 3 hours, and dissolve in methanol to make exactly 250 mL. Pipet 6 mL of this solution, add exactly 3 mL of the internal standard solution, add methanol to make 50 mL, and use this solution as the standard solution. Perform the test with 10 μ L each of the sample solution and standard solution as directed under Liquid Chromatography <2.01> according to the following conditions, and calculate the ratios, Q_T and Q_S , of the peak area of felbinac to that of the internal standard.

$$\begin{aligned} &\text{Amount (mg) of felbinac (C}_{14}\text{H}_{12}\text{O}_2\text{)} \\ &= M_S \times Q_T / Q_S \times 2 \end{aligned}$$

M_S : Amount (mg) of felbinac for assay taken

Internal standard solution—A solution of indometacin in methanol (1 in 1250).

Operating conditions—

Detector: An ultraviolet absorption photometer (wavelength: 254 nm).

Column: A stainless steel column 4.6 mm in inside diameter and 15 cm in length, packed with octadecylsilanized silica gel for liquid chromatography (5 μ m in particle diameter).

Column temperature: A constant temperature of about 40°C.

Mobile phase: To 1.5 mL of phosphoric acid add 300 mL of water, then dissolve 5 g of sodium lauryl sulfate, and add water to make 500 mL. To this solution add 500 mL of acetonitrile.

Flow rate: Adjust so that the retention time of felbinac is about 6 minutes.

System suitability—

System performance: When the procedure is run with 10 μ L of the standard solution under the above operating conditions, felbinac and the internal standard are eluted in this order with the resolution between these peaks being not less than 6.

System repeatability: When the test is repeated 6 times with 10 μ L of the standard solution under the above operating conditions, the relative standard deviation of the ratio of the peak area of felbinac to that of the internal standard is not more than 1.0%.

Containers and storage Containers—Tight containers.

Felbinac Tape

フェルビナクテープ

Felbinac Tape contains not less than 90.0% and not more than 110.0% of the labeled amount of felbinac ($C_{14}H_{12}O_2$: 212.24).

Method of preparation Prepare as directed under Tapes/Plasters, with Felbinac.

Identification Cut up a quantity of Felbinac Tape, equivalent to 5 mg of Felbinac, add 30 mL of ethanol (95), and heat under a reflux condenser. After cooling, separate the ethanol extract, add ethanol (95) to make 50 mL, and filter. To 5 mL of the filtrate add ethanol (95) to make 100 mL, and determine the absorption spectrum of this solution as directed under Ultraviolet-visible Spectrophotometry <2.24>: it exhibits a maximum between 251 nm and 255 nm.

Adhesiveness Being specified separately when the drug is granted approval based on the Law.

Drug release Being specified separately when the drug is granted approval based on the Law.

Assay Take exactly a quantity of Felbinac Tape, equivalent to 35 mg of felbinac ($C_{14}H_{12}O_2$), cut up them, add 60 mL of acetone, sonicate, and heat under a reflux condenser. After cooling, separate the acetone extract, and repeat the extraction twice more with 60 mL each of acetone by heating under a reflux condenser. After cooling, separate the extract, wash the residue and vessel with a small volume of acetone, combine the washings and the extracts, and add acetone to

make exactly 250 mL. Pipet 6 mL of this solution, add exactly 2 mL of the internal standard solution and the mobile phase to make 50 mL, and use this solution as the sample solution. Separately, weigh accurately about 14 mg of felbinac for assay, previously dried at 105°C for 3 hours, and dissolve in acetone to make exactly 100 mL. Pipet 6 mL of this solution, add exactly 2 mL of the internal standard solution and the mobile phase to make 50 mL, and use this solution as the standard solution. Perform the test with 20 μ L each of the sample solution and standard solution as directed under Liquid Chromatography <2.01> according to the following conditions, and calculate the ratios, Q_T and Q_S , of the peak area of felbinac to that of the internal standard.

$$\begin{aligned} \text{Amount (mg) of felbinac (C}_{14}\text{H}_{12}\text{O}_2) \\ = M_S \times Q_T / Q_S \times 5/2 \end{aligned}$$

M_S : Amount (mg) of felbinac for assay taken

Internal standard solution—A solution of indomethacin in acetone (1 in 1250).

Operating conditions—

Detector: An ultraviolet absorption photometer (wavelength: 254 nm).

Column: A stainless steel column 4.6 mm in inside diameter and 25 cm in length, packed with octadecylsilanized silica gel for liquid chromatography (5 μ m in particle diameter).

Column temperature: A constant temperature of about 40°C.

Mobile phase: A mixture of water, acetonitrile and phosphoric acid (500:500:1).

Flow rate: Adjust so that the retention time of felbinac is about 7 minutes.

System suitability—

System performance: When the procedure is run with 20 μ L of the standard solution under the above operating conditions, felbinac and the internal standard are eluted in this order with the resolution between these peaks being not less than 3.

System repeatability: When the test is repeated 6 times with 20 μ L of the standard solution under the above operating conditions, the relative standard deviation of the ratio of the peak area of felbinac to that of the internal standard is not more than 1.0%.

Containers and storage Containers—Well-closed containers.

Felodipine

フェロジピン

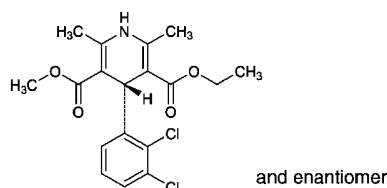

$\text{C}_{18}\text{H}_{19}\text{Cl}_2\text{NO}_4$: 384.25

Ethyl methyl (4*RS*)-4-(2,3-dichlorophenyl)-2,6-dimethyl-1,4-dihydropyridine-3,5-dicarboxylate
[72509-76-3]

Felodipine contains not less than 99.0% and not more than 101.0% of felodipine ($\text{C}_{18}\text{H}_{19}\text{Cl}_2\text{NO}_4$), calculated on the dried basis.

Description Felodipine occurs as pale yellow-white to light yellow-white, crystals or crystalline powder.

It is freely soluble in methanol and in ethanol (99.5), and practically insoluble in water.

A solution of Felodipine in methanol (1 in 20) shows no optical rotation.

Identification (1) Determine the absorption spectrum of a solution of Felodipine in methanol (1 in 62,500) as directed under Ultraviolet-visible Spectrophotometry <2.24>, and compare the spectrum with the Reference Spectrum: both spectra exhibit similar intensities of absorption at the same wavelengths.

(2) Determine the infrared absorption spectrum of Felodipine as directed in the potassium bromide disk method under Infrared Spectrophotometry <2.25>, and compare the spectrum with the Reference Spectrum: both spectra exhibit similar intensities of absorption at the same wave numbers.

Purity (1) Heavy metals—Being specified separately when the drug is granted approval based on the Law.

(2) Related substances—Dissolve 25 mg of Felodipine in 50 mL of the mobile phase, and use this solution as the sample solution. Pipet 1 mL of the sample solution, and add the mobile phase to make exactly 100 mL. Pipet 1 mL of this solution, add the mobile phase to make exactly 10 mL, and use this solution as the standard solution. Perform the test with exactly 20 μ L each of the sample solution and standard solution as directed under Liquid Chromatography <2.01> according to the following conditions. Determine each peak area by the automatic integration method: the area of the peak other than felodipine, related substance B having the relative retention time of about 0.7 to felodipine, and related substance C having the relative retention time of about 1.4 obtained from the sample solution is not larger than the peak area of felodipine from the standard solution. Furthermore, the total area of the peaks of related substances B and C from the sample solution is not larger than 10 times the peak area of felodipine from the standard solution, and the total area of the peaks other than felodipine and related substances mentioned above from the sample solution is not larger than 3 times the peak area of felodipine from the standard solution. For this calculation the peak area less than 1/5 times the peak area of felodipine from the standard solution is excluded.

Operating conditions—

Detector: An ultraviolet absorption photometer (wavelength: 254 nm).

Column: A stainless steel column 4.6 mm in inside diameter and 15 cm in length, packed with octadecylsilanized silica gel for liquid chromatography (5 μ m in particle diameter).

Column temperature: A constant temperature of about 25°C.

Mobile phase: Dissolve 3.2 g of sodium dihydrogen phosphate dihydrate in 400 mL of water, adjust to pH 3.0 with phosphoric acid, and add 200 mL of methanol and 400 mL of acetonitrile.

Flow rate: Adjust so that the retention time of felodipine is about 12 minutes.

Time span of measurement: About 2 times as long as the retention time of felodipine, beginning after the solvent peak.

System suitability—

Test for required detectability: When the procedure is run with 20 μ L of the standard solution under the above operating conditions, the SN ratio of the peak of felodipine is not less than 30.

System performance: When the procedure is run with 20

μL of the standard solution under the above operating conditions, the number of theoretical plates and the symmetry factor of the peak of felodipine are not less than 5000 and not more than 1.5, respectively.

System repeatability: When the test is repeated 6 times with 20 μL of the standard solution under the above operating conditions, the relative standard deviation of the peak area of felodipine is not more than 2.0%.

Loss on drying <2.41> Not more than 0.2% (1 g, 105°C, 3 hours).

Residue on ignition <2.44> Not more than 0.1% (1 g).

Assay Weigh accurately about 0.16 g of Felodipine, dissolve in 25 mL of *t*-butyl alcohol and 25 mL of diluted perchloric acid (17 in 200), and titrate <2.50> with 0.1 mol/L cerium (IV) sulfate VS (indicator: 50 μL of 1,10-phenanthroline TS) until the color of the solution changes from orange to colorless. Perform a blank determination in the same manner, and make any necessary correction.

Each mL of 0.1 mol/L cerium (IV) sulfate VS
= 19.21 mg of $\text{C}_{18}\text{H}_{19}\text{Cl}_2\text{NO}_4$

Containers and storage Containers—Well-closed containers.

Others

Related substance B:

Dimethyl 4-(2,3-dichlorophenyl)-2,6-dimethyl-1,4-dihydropyridine-3,5-dicarboxylate

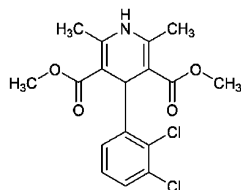

Related substance C:

Diethyl 4-(2,3-dichlorophenyl)-2,6-dimethyl-1,4-dihydropyridine-3,5-dicarboxylate

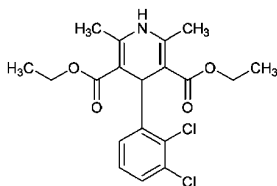

Felodipine Tablets

フェロジピン錠

Felodipine Tablets contain not less than 95.0% and not more than 105.0% of the labeled amount of felodipine ($\text{C}_{18}\text{H}_{19}\text{Cl}_2\text{NO}_4$; 384.25).

Method of preparation Prepare as directed under Tablets, with Felodipine.

Identification To a quantity of powdered Felodipine Tablets, equivalent to 4 mg of Felodipine, add 200 mL of methanol, shake thoroughly, add methanol to make 250 mL, and centrifuge. Determine the absorption spectrum of the supernatant liquid as directed under Ultraviolet-visible Spectrophotometry <2.24>: it exhibits maxima between 235 nm and 239 nm, and between 357 nm and 363 nm.

Uniformity of dosage units <6.02> Perform the Mass varia-

tion test, or the Content uniformity test according to the following method: it meets the requirement.

To 1 tablet of Felodipine Tablets add 1 mL of water per 2.5 mg of felodipine ($\text{C}_{18}\text{H}_{19}\text{Cl}_2\text{NO}_4$), and shake thoroughly until the tablet is completely disintegrated. Add exactly 1 mL of the internal standard solution per 2.5 mg of felodipine ($\text{C}_{18}\text{H}_{19}\text{Cl}_2\text{NO}_4$), and add methanol to make V mL so that each mL contains about 0.25 mg of felodipine ($\text{C}_{18}\text{H}_{19}\text{Cl}_2\text{NO}_4$). Centrifuge this solution, filter the supernatant liquid, and use this filtrate as the sample solution. Separately, weigh accurately about 25 mg of felodipine for assay (separately determine the loss on drying <2.41> in the same conditions as Felodipine), add 10 mL of water, and add exactly 10 mL of the internal standard solution. Add methanol to make 100 mL, and use this solution as the standard solution. Then, proceed as directed in the Assay.

$$\begin{aligned} \text{Amount (mg) of felodipine (C}_{18}\text{H}_{19}\text{Cl}_2\text{NO}_4) \\ = M_S \times Q_T/Q_S \times V/100 \end{aligned}$$

M_S : Amount (mg) of felodipine for assay taken, calculated on the dried basis

Internal standard solution—A solution of butyl parahydroxybenzoate in methanol (1 in 3000).

Dissolution <6.10> When the test is performed at 50 revolutions per minute according to the Paddle method, using 900 mL of a solution prepared by dissolving 1 g of polysorbate 80 in water to make 5000 mL, as the dissolution medium, the dissolution rates in 45 minutes of a 2.5-mg tablet and a 5-mg tablet are not less than 80% and not less than 75%, respectively.

Start the test with 1 tablet of Felodipine Tablets, withdraw not less than 20 mL of the medium at the specified minute after starting the test, and filter through a membrane filter with a pore size not exceeding 0.45 μm . Discard not less than 10 mL of the first filtrate, pipet V mL of the subsequent filtrate, add the dissolution medium to make exactly V' mL so that each mL contains about 2.8 μg of felodipine ($\text{C}_{18}\text{H}_{19}\text{Cl}_2\text{NO}_4$), and use this solution as the sample solution. Separately, weigh accurately about 28 mg of felodipine for assay (separately determine the loss on drying <2.41> in the same conditions as Felodipine), and dissolve in methanol to make exactly 200 mL. Pipet 2 mL of this solution, add the dissolution medium to make exactly 100 mL, and use this solution as the standard solution. Perform the test with exactly 50 μL each of the sample solution and standard solution as directed under Liquid Chromatography <2.01> according to the following conditions, and determine the peak areas, A_T and A_S , of felodipine in each solution.

$$\begin{aligned} \text{Dissolution rate (\%)} \text{ with respect to the labeled amount} \\ \text{of felodipine (C}_{18}\text{H}_{19}\text{Cl}_2\text{NO}_4) \\ = M_S \times A_T/A_S \times V'/V \times 1/C \times 9 \end{aligned}$$

M_S : Amount (mg) of felodipine for assay taken, calculated on the dried basis

C : Labeled amount (mg) of felodipine ($\text{C}_{18}\text{H}_{19}\text{Cl}_2\text{NO}_4$) in 1 tablet

Operating conditions—

Column, column temperature, mobile phase and flow rate: Proceed as directed in the operating conditions in the Assay.

Detector: An ultraviolet absorption photometer (wavelength: 238 nm).

System suitability—

System performance: When the procedure is run with 50 μL of the standard solution under the above operating conditions, the number of theoretical plates and the symmetry

factor of the peak of felodipine are not less than 3000 and not more than 1.5, respectively.

System repeatability: When the test is repeated 6 times with 50 μL of the standard solution under the above operating conditions, the relative standard deviation of the peak area of felodipine is not more than 2.0%.

Assay Weigh accurately the mass of not less than 20 Felodipine Tablets, and powder. Weigh accurately a portion of the powder, equivalent to about 10 mg of felodipine ($\text{C}_{18}\text{H}_{19}\text{Cl}_2\text{NO}_4$), add 20 mL of water, add exactly 4 mL of the internal standard solution, add methanol to make 100 mL and shake. Centrifuge this solution, filter the supernatant liquid through a membrane filter with a pore size not exceeding 0.45 μm , and use the filtrate as the sample solution. Separately, weigh accurately about 10 mg of felodipine for assay (separately determine the loss on drying <2.41> in the same conditions as Felodipine), add 20 mL of water, add exactly 4 mL of the internal standard solution, add methanol to make 100 mL, and use this solution as the standard solution. Perform the test with 20 μL each of the sample solution and standard solution as directed under Liquid Chromatography <2.01> according to the following conditions, and calculate the ratios, Q_T and Q_S , of the peak area of felodipine to that of the internal standard.

Amount (mg) of felodipine ($\text{C}_{18}\text{H}_{19}\text{Cl}_2\text{NO}_4$) = $M_S \times Q_T/Q_S$

M_S : Amount (mg) of felodipine for assay taken, calculated on the dried basis

Internal standard solution—A solution of butyl parahydroxybenzoate in methanol (1 in 6000).

Operating conditions—

Detector: An ultraviolet absorption photometer (wavelength: 264 nm).

Column: A stainless steel column 4.6 mm in inside diameter and 15 cm in length, packed with octadecylsilanized silica gel for liquid chromatography (5 μm in particle diameter).

Column temperature: A constant temperature of about 25°C.

Mobile phase: A mixture of methanol, water, a solution of sodium perchlorate monohydrate (281 in 2000) and diluted perchloric acid (17 in 200) (65:25:8:2).

Flow rate: Adjust so that the retention time of felodipine is about 12 minutes.

System suitability—

System performance: When the procedure is run with 20 μL of the standard solution under the above operating conditions, the internal standard and felodipine are eluted in this order with the resolution between these peaks being not less than 5.

System repeatability: When the test is repeated 6 times with 20 μL of the standard solution under the above operating conditions, the relative standard deviation of the peak area of felodipine is not more than 1.0%.

Containers and storage Containers—Tight containers.

Fenbufen

フェンブフェン

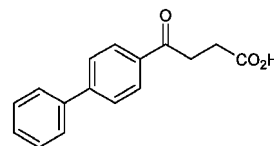

$\text{C}_{16}\text{H}_{14}\text{O}_3$: 254.28

4-(Biphenyl-4-yl)-4-oxobutanoic acid

[36330-85-5]

Fenbufen, when dried, contains not less than 98.0% of fenbufen ($\text{C}_{16}\text{H}_{14}\text{O}_3$).

Description Fenbufen occurs as a white crystalline powder. It has a bitter taste.

It is sparingly soluble in acetone, slightly soluble in methanol, in ethanol (95) and in diethyl ether, and practically insoluble in water.

Melting point: about 188°C (with decomposition).

Identification (1) Determine the absorption spectrum of a solution of Fenbufen in ethanol (95) (1 in 200,000) as directed under Ultraviolet-visible Spectrophotometry <2.24>, and compare the spectrum with the Reference Spectrum: both spectra exhibit similar intensities of absorption at the same wavelengths.

(2) Determine the infrared absorption spectrum of Fenbufen, previously dried, as directed in the potassium bromide disk method under Infrared Spectrophotometry <2.25>, and compare the spectrum with the Reference Spectrum: both spectra exhibit similar intensities of absorption at the same wave numbers.

Purity (1) Heavy metals <1.07>—Take 2.0 g of Fenbufen, add 2 mL of sulfuric acid, and carbonize by gentle heating, proceed according to Method 2, and perform the test. Prepare the control solution with 2.0 mL of Standard Lead Solution (not more than 10 ppm).

(2) Arsenic <1.11>—Prepare the test solution with 1.0 g of Fenbufen according to Method 3, and perform the test (not more than 2 ppm).

(3) Related substances—Dissolve 0.1 g of Fenbufen in 20 mL of acetone, and use this solution as the sample solution. Pipet 1 mL of the sample solution, add acetone to make exactly 100 mL, and use this solution as the standard solution. Perform the test with these solutions as directed under Thin-layer Chromatography <2.03>. Spot 10 μL each of the sample solution and standard solution on a plate of silica gel with fluorescent indicator for thin-layer chromatography. Develop the plate with a mixture of dichloromethane, methanol and water (80:20:3) to a distance of about 10 cm, and air-dry the plate. Examine under ultraviolet light (main wavelength: 254 nm): the spots other than the principal spot obtained from the sample solution are not more intense than the spot from the standard solution.

Loss on drying <2.41> Not more than 0.3% (1 g, 105°C, 3 hours).

Residue on ignition <2.44> Not more than 0.1% (1 g).

Assay Weigh accurately about 0.2 g of Fenbufen, previously dried, dissolve in 100 mL of ethanol (99.5), and titrate <2.50> with 0.1 mol/L potassium hydroxide-ethanol VS (potentiometric titration). Perform a blank determination in

the same manner, and make any necessary correction.

Each mL of 0.1 mol/L potassium hydroxide-ethanol VS
= 25.43 mg of C₁₆H₁₄O₃

Containers and storage Containers—Tight containers.

Fenofibrate

フェノフィブラート

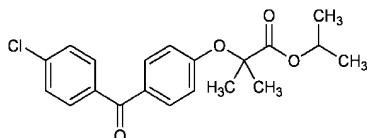

C₂₀H₂₁ClO₄: 360.83

1-Methylethyl 2-[4-(4-chlorobenzoyl)phenoxy]-2-methylpropanoate
[49562-28-9]

Fenofibrate, when dried, contains not less than 98.5% and not more than 101.0% of fenofibrate (C₂₀H₂₁ClO₄).

Description Fenofibrate occurs as a white to pale yellow-white crystalline powder.

It is soluble in ethanol (99.5), and practically insoluble in water.

It shows crystal polymorphism.

Identification (1) Determine the absorption spectrum of a solution of Fenofibrate in ethanol (99.5) (1 in 80,000) as directed under Ultraviolet-visible Spectrophotometry <2.24>, and compare the spectrum with the Reference Spectrum or the spectrum of a solution of Fenofibrate RS prepared in the same manner as the sample solution: both spectra exhibit similar intensities of absorption at the same wavelengths.

(2) Determine the infrared absorption spectrum of Fenofibrate, previously dried, as directed in the potassium bromide disk method under Infrared Spectrophotometry <2.25>, and compare the spectrum with the Reference Spectrum or the spectrum of dried Fenofibrate RS: both spectra exhibit similar intensities of absorption at the same wave numbers.

(3) Perform the test with Fenofibrate as directed under Flame Coloration Test <1.04>: a green color appears.

Melting point <2.60> 80 – 83°C

Purity (1) Heavy metals <1.07>—Proceed with 1.0 g of Fenofibrate according to Method 4, and perform the test. Prepare the control solution with 2.0 mL of Standard Lead Solution (not more than 20 ppm).

(2) Related substances—Conduct this procedure using light-resistant vessels. Dissolve 0.10 g of Fenofibrate in a mixture of acetonitrile and water (7:3) to make 100 mL. To 5 mL of this solution add a mixture of acetonitrile and water (7:3) to make 25 mL, and use this solution as the sample solution. Pipet 3 mL of the sample solution, add a mixture of acetonitrile and water (7:3) to make exactly 50 mL. Pipet 2.5 mL of this solution, add a mixture of acetonitrile and water (7:3) to make exactly 50 mL, and use this solution as the standard solution. Perform the test with exactly 20 μL each of the sample solution and standard solution as directed under Liquid Chromatography <2.01> according to the following conditions, and determine each peak area by the automatic integration method: the peak area of related substance A having the relative retention time of about 1.4 to

fenofibrate, obtained from the sample solution is not larger than 4/5 times the peak area of fenofibrate from the standard solution, and the total area of the peaks other than fenofibrate from the sample solution is not larger than the peak area of fenofibrate from the standard solution.

Operating conditions—

Detector, column, column temperature, mobile phase, and flow rate: Proceed as directed in the operating conditions in the Assay.

Time span of measurement: About 2 times as long as the retention time of fenofibrate, beginning after the solvent peak.

System suitability—

Test for required detectability: Pipet 5 mL of the standard solution, and add a mixture of acetonitrile and water (7:3) to make exactly 25 mL. Confirm that the peak area of fenofibrate obtained with 20 μL of this solution is equivalent to 15 to 25% of that with 20 μL of the standard solution.

System performance: Dissolve 0.10 g each of Fenofibrate and 4-chlorobenzophenon in 100 mL of a mixture of acetonitrile and water (7:3). To 2 mL of this solution add a mixture of acetonitrile and water (7:3) to make 50 mL. To 1 mL of this solution add a mixture of acetonitrile and water (7:3) to make 50 mL. When the procedure is run with 20 μL of this solution under the above operating conditions, 4-chlorobenzophenon and fenofibrate are eluted in this order with the resolution between these peaks being not less than 10.

System repeatability: When the test is repeated 6 times with 20 μL of the standard solution under the above operating conditions, the relative standard deviation of the peak area of fenofibrate is not more than 5%.

Loss on drying <2.41> Not more than 0.5% (1 g, in vacuum, phosphorus (V) oxide, 60°C, 4 hours).

Residue on ignition <2.44> Not more than 0.1% (1 g).

Assay Conduct this procedure using light-resistant vessels. Weigh accurately about 50 mg each of Fenofibrate and Fenofibrate RS, both previously dried, dissolve each in a mixture of acetonitrile and water (7:3) to make exactly 50 mL. Pipet 2 mL each of these solutions, add exactly 2 mL of the internal standard solution to each, add a mixture of acetonitrile and water (7:3) to make 50 mL, and use these solutions as the sample solution and the standard solution, respectively. Perform the test with 20 μL each of the sample solution and standard solution as directed under Liquid Chromatography <2.01> according to the following conditions, and calculate the ratios, Q_T and Q_S , of the peak area of fenofibrate to the internal standard.

$$\begin{aligned} &\text{Amount (mg) of fenofibrate (C}_{20}\text{H}_{21}\text{ClO}_4) \\ &= M_S \times Q_T / Q_S \end{aligned}$$

M_S : Amount (mg) of Fenofibrate RS taken

Internal standard solution—A solution of 4-chlorobenzophenon in a mixture of acetonitrile and water (7:3) (11 in 10,000).

Operating conditions—

Detector: An ultraviolet absorption photometer (wavelength: 286 nm).

Column: A stainless steel column 4.6 mm in inside diameter and 15 cm in length, packed with octadecylsilanized silica gel for liquid chromatography (5 μm in particle diameter).

Column temperature: A constant temperature of about 40°C.

Mobile phase: A mixture of acetonitrile and 0.02 mol/L phosphate buffer solution (pH 3.0) (7:3).

Flow rate: Adjust so that the retention time of fenofibrate

is about 8 minutes.

System suitability—

System performance: When the procedure is run with 20 μL of the standard solution under the above operating conditions, the internal standard and fenofibrate are eluted in this order with the resolution between these peaks being not less than 10.

System repeatability: When the test is repeated 6 times with 20 μL of the standard solution under the above operating conditions, the relative standard deviation of the ratio of the peak area of fenofibrate to that of the internal standard is not more than 1.0%.

Containers and storage Containers—Tight containers.

Storage—Light-resistant.

Others

Related substance A:

2-Methyl-1-(1-methylethoxy)-1-oxopropan-2-yl 2-[4-(4-chlorobenzoyl)phenoxy]-2-methylpropanoate

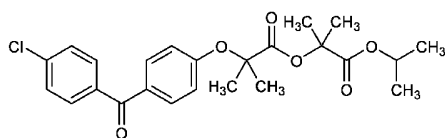

Fenofibrate Tablets

フェノフィブラート錠

Fenofibrate Tablets contain not less than 95.0% and not more than 105.0% of the labeled amount of fenofibrate ($\text{C}_{20}\text{H}_{21}\text{ClO}_4$; 360.83).

Method of preparation Prepare as directed under Tablets, with Fenofibrate.

Identification To a quantity of powdered Fenofibrate Tablets, equivalent to 10 mg of Fenofibrate, add 10 mL of a mixture of acetonitrile and water (7:3), shake, and centrifuge. To 1 mL of the supernatant liquid add a mixture of acetonitrile and water (7:3) to make 100 mL. Determine the absorption spectrum of this solution as directed under Ultraviolet-visible Spectrophotometry <2.24>; it exhibits a maximum between 285 nm and 289 nm.

Purity Related substances—Conduct this procedure using light-resistant vessels. To 4 mL of the supernatant liquid obtained in the Assay add a mixture of acetonitrile and water (7:3) to make 10 mL, and use this solution as the sample solution. Pipet 1 mL of this solution, and add a mixture of acetonitrile and water (7:3) to make exactly 20 mL. Pipet 5 mL of this solution, add a mixture of acetonitrile and water (7:3) to make exactly 50 mL, and use this solution as the standard solution. Perform the test with exactly 10 μL each of the sample solution and standard solution as directed under Liquid Chromatography <2.01> according to the following conditions, and determine each peak area by the automatic integration method: the area of the peak other than fenofibrate and related substance A having the relative retention time of about 1.4 to fenofibrate obtained from the sample solution, is not larger than 2/5 times the peak area of fenofibrate from the standard solution, and the total area of the peaks other than fenofibrate from the sample solution is not larger than the peak area of fenofibrate from the standard solution.

Operating conditions—

Detector, column temperature, and mobile phase: Proceed as directed in the operating conditions in the Assay under Fenofibrate.

Column: A stainless steel column 4.6 mm in inside diameter and 25 cm in length, packed with octadecylsilanized silica gel for liquid chromatography (5 μm in particle diameter).

Flow rate: Adjust so that the retention time of fenofibrate is about 21 minutes.

Time span of measurement: About 2 times as long as the retention time of fenofibrate, beginning after the solvent peak.

System suitability—

Test for required detectability: Pipet 1 mL of the standard solution, and add a mixture of acetonitrile and water (7:3) to make exactly 10 mL. Confirm that the peak area of fenofibrate obtained with 10 μL of this solution is equivalent to 7 to 13% of that with 10 μL of the standard solution.

System performance: When the procedure is run with 10 μL of the standard solution under the above operating conditions, the number of theoretical plates and the symmetry factor of the peak of fenofibrate are not less than 10,000 and 0.8 to 1.5, respectively.

System repeatability: When the test is repeated 6 times with 10 μL of the standard solution under the above operating conditions, the relative standard deviation of the peak area of fenofibrate is not more than 3.0%.

Uniformity of dosage units <6.02> Perform the Mass variation test, or the Content uniformity test according to the following method: it meets the requirement.

Conduct this procedure using light-resistant vessels. To 1 tablet of Fenofibrate Tablets add exactly 20 mL of a mixture of acetonitrile and water (7:3), and shake until the tablet is disintegrated. Centrifuge this solution, pipet V mL of the supernatant liquid, equivalent to about 20 mg of fenofibrate ($\text{C}_{20}\text{H}_{21}\text{ClO}_4$), and add a mixture of acetonitrile and water (7:3) to make exactly 20 mL. Pipet 2 mL of this solution, add exactly 2 mL of the internal standard solution, add a mixture of acetonitrile and water (7:3) to make 50 mL, and use this solution as the sample solution. Then, proceed as directed in the Assay.

$$\begin{aligned} &\text{Amount (mg) of fenofibrate (C}_{20}\text{H}_{21}\text{ClO}_4) \\ &= M_S \times Q_T/Q_S \times 8/V \end{aligned}$$

M_S : Amount (mg) of Fenofibrate RS taken

Dissolution <6.10> When the test is performed at 50 revolutions per minute according to the Paddle method, using 900 mL of a solution prepared by dissolving 1 g of polysorbate 80 in water to make 100 mL as the dissolution medium, the dissolution rate in 30 minutes of Fenofibrate Tablets is not less than 75%.

Conduct this procedure using light-resistant vessels. Start the test with 1 tablet of Fenofibrate Tablets, withdraw not less than 10 mL of the medium at the specified minute after starting the test, and filter through a membrane filter with a pore size not exceeding 0.45 μm . Discard not less than 5 mL of the first filtrate, pipet V mL of the subsequent filtrate, add the dissolution medium to make exactly V' mL so that each mL contains about 59 μg of fenofibrate ($\text{C}_{20}\text{H}_{21}\text{ClO}_4$), and use this solution as the sample solution. Separately, weigh accurately about 12 mg of Fenofibrate RS, previously dried in vacuum over phosphorus (V) oxide at 60°C for 4 hours, and dissolve in a mixture of acetonitrile and water (7:3) to make exactly 20 mL. Pipet 2 mL of this solution add the dissolution medium to make exactly 20 mL, and use this solution as the standard solution. Perform the test with ex-

actly 10 μL each of the sample solution and standard solution as directed under Liquid Chromatography <2.01> according to the following conditions, and determine the peak areas, A_T and A_S , of fenofibrate in each solution.

Dissolution rate (%) with respect to the labeled amount of fenofibrate ($\text{C}_{20}\text{H}_{21}\text{ClO}_4$)

$$= M_S \times A_T / A_S \times V' / V \times 1 / C \times 450$$

M_S : Amount (mg) of Fenofibrate RS taken

C : Labeled amount (mg) of fenofibrate ($\text{C}_{20}\text{H}_{21}\text{ClO}_4$) in 1 tablet

Operating conditions—

Detector, column, and column temperature: Proceed as directed in the operating conditions in the Assay under Fenofibrate.

Mobile phase: A mixture of acetonitrile and 0.02 mol/L phosphate buffer solution (pH 3.0) (4:1).

Flow rate: Adjust so that the retention time of fenofibrate is about 4 minutes.

System suitability—

System performance: When the procedure is run with 10 μL of the standard solution under the above operating conditions, the number of theoretical plates and the symmetry factor of the peak of fenofibrate are not less than 4000 and not more than 2.0, respectively.

System repeatability: When the test is repeated 6 times with 10 μL of the standard solution under the above operating conditions, the relative standard deviation of the peak area of fenofibrate is not more than 2.0%.

Assay Conduct this procedure using light-resistant vessels. Weigh accurately the mass of not less than 20 tablets of Fenofibrate Tablets, and powder. Weigh accurately a portion of the powder, equivalent to about 50 mg of fenofibrate ($\text{C}_{20}\text{H}_{21}\text{ClO}_4$), add 30 mL of a mixture of acetonitrile and water (7:3), shake thoroughly, and add a mixture of acetonitrile and water (7:3) to make exactly 50 mL. Centrifuge this solution, pipet 2 mL of the supernatant liquid, add exactly 2 mL of the internal standard solution, add a mixture of acetonitrile and water (7:3) to make 50 mL, and use this solution as the sample solution. Separately, weigh accurately about 50 mg of Fenofibrate RS, previously dried in vacuum over phosphorus (V) oxide at 60°C for 4 hours, and dissolve in a mixture of acetonitrile and water (7:3) to make exactly 50 mL. Pipet 2 mL of this solution, add exactly 2 mL of the internal standard solution, add a mixture of acetonitrile and water (7:3) to make 50 mL, and use this solution as the standard solution. Perform the test with 20 μL each of the sample solution and standard solution as directed under Liquid Chromatography <2.01> according to the following conditions, and calculate the ratios, Q_T and Q_S , of the peak area of fenofibrate to that of the internal standard.

Amount (mg) of fenofibrate ($\text{C}_{20}\text{H}_{21}\text{ClO}_4$)

$$= M_S \times Q_T / Q_S$$

M_S : Amount (mg) of Fenofibrate RS for assay taken

Internal standard solution—A solution of 4-chlorobenzophenone in a mixture of acetonitrile and water (7:3) (1 in 10,000).

Operating conditions—

Proceed as directed in the operating conditions in the Assay under Fenofibrate.

System suitability—

Proceed as directed in the system suitability in the Assay under Fenofibrate.

Containers and storage Containers—Tight containers.

Storage—Light-resistant.

Others

Related substance A: Refer to it described in Fenofibrate.

Fentanyl Citrate

フェンタニルクエン酸塩

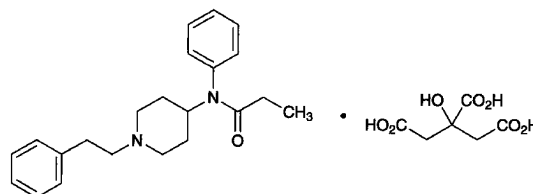

$\text{C}_{22}\text{H}_{28}\text{N}_2\text{O} \cdot \text{C}_6\text{H}_8\text{O}_7$; 528.59

N-(1-Phenethylpiperidin-4-yl)-*N*-phenylpropanamide
monocitrate
[990-73-8]

Fentanyl Citrate contains not less than 98.0% of fentanyl citrate ($\text{C}_{22}\text{H}_{28}\text{N}_2\text{O} \cdot \text{C}_6\text{H}_8\text{O}_7$), calculated on the dried basis.

Description Fentanyl Citrate occurs as white, crystals or crystalline powder.

It is freely soluble in methanol and in acetic acid (100), sparingly soluble in water and in ethanol (95), and very slightly soluble in diethyl ether.

Identification (1) Dissolve 0.05 g of Fentanyl Citrate in 10 mL of 0.1 mol/L hydrochloric acid TS and ethanol (95) to make 100 mL. Determine the absorption spectrum of the solution as directed under Ultraviolet-visible Spectrophotometry <2.24>, and compare the spectrum with the Reference Spectrum: both spectra exhibit similar intensities of absorption at the same wavelengths.

(2) Determine the infrared absorption spectrum of Fentanyl Citrate, previously dried, as directed in the potassium bromide disk method under Infrared Spectrophotometry <2.25>, and compare the spectrum with the Reference Spectrum: both spectra exhibit similar intensities of absorption at the same wave numbers.

(3) A solution of Fentanyl Citrate (1 in 100) responds to Qualitative Tests <1.09> (1) for citrate.

pH <2.54> Dissolve 0.10 g of Fentanyl Citrate in 10 mL of water: the pH of this solution is between 3.0 and 5.0.

Melting point <2.60> 150 – 154°C

Purity (1) Heavy metals <1.07>—Proceed with 0.5 g of Fentanyl Citrate according to Method 2, and perform the test. Prepare the control solution with 1.0 mL of Standard Lead Solution (not more than 20 ppm).

(2) Related substances—Dissolve 0.10 g of Fentanyl Citrate in 5 mL of methanol, and use this solution as the sample solution. Pipet 1 mL of the sample solution, add methanol to make exactly 100 mL, and use this solution as the standard solution. Perform the test with these solutions as directed under Thin-layer Chromatography <2.03>. Spot 5 μL each of the sample solution and standard solution on a plate of silica gel for thin-layer chromatography. Develop the plate with a mixture of 1-butanol, water and acetic acid (100) (3:1:1) to a distance of about 10 cm, and air-dry the plate. Spray evenly Dragendorff's TS for spraying on the plate: the spots other than the principal spot obtained from

the sample solution are not more intense than the spot from the standard solution.

Loss on drying <2.41> Not more than 0.5% (0.2 g, in vacuum, silica gel, 60°C, 2 hours).

Residue on ignition <2.44> Not more than 0.2% (0.5 g).

Assay Weigh accurately about 75 mg of Fentanyl Citrate, dissolve in 50 mL of acetic acid (100), and titrate <2.50> with 0.02 mol/L perchloric acid VS (potentiometric titration). Perform a blank determination in the same manner, and make any necessary correction.

Each mL of 0.02 mol/L perchloric acid VS
= 10.57 mg of $C_{22}H_{28}N_2O \cdot C_6H_8O_7$

Containers and storage Containers—Tight containers.
Storage—Light-resistant.

Ferrous Sulfate Hydrate

硫酸鉄水和物

$FeSO_4 \cdot 7H_2O$: 278.01

Ferrous Sulfate Hydrate contains not less than 98.0% and not more than 104.0% of ferrous sulfate hydrate ($FeSO_4 \cdot 7H_2O$).

Description Ferrous Sulfate Hydrate occurs as pale green, crystals or crystalline powder. It is odorless, and has an astringent taste.

It is freely soluble in water, and practically insoluble in ethanol (95) and in diethyl ether.

It is efflorescent in dry air, and its surface becomes yellowish brown in moist air.

Identification A solution of Ferrous Sulfate Hydrate (1 in 10) responds to Qualitative Tests <1.09> for ferrous salt and for sulfate.

Purity (1) Clarity of solution—Dissolve 1.0 g of Ferrous Sulfate Hydrate in 20 mL of water and 1 mL of dilute sulfuric acid: the solution is clear.

(2) Acidity—To 5.0 g of powdered Ferrous Sulfate Hydrate add 50 mL of ethanol (95), shake well for 2 minutes, and filter the mixture. To 25 mL of the filtrate add 50 mL of water, 3 drops of bromothymol blue TS and 0.5 mL of dilute sodium hydroxide TS: a blue color develops.

(3) Heavy metals <1.07>—Take 1.0 g of Ferrous Sulfate Hydrate in a porcelain dish, add 3 mL of aqua regia, and dissolve. Then evaporate on a water bath to dryness. To the residue add 5 mL of 6 mol/L hydrochloric acid TS, and dissolve. Transfer this solution to a separator. Wash the porcelain dish with two 5-mL portions of 6 mol/L hydrochloric acid TS, and combine the washings and the solution in the separator. Pour two 40-mL portions and one 20-mL portion of diethyl ether in the separator, shaking each time to mix. Allow to stand, and discard each separated diethyl ether layer. To the aqueous layer add 0.05 g of hydroxylammonium chloride, dissolve, and heat on a water bath for 10 minutes. Cool, adjust the solution to a pH of 3 to 4 by dropping ammonia solution (28), add water to make 50 mL, and perform the test using this solution as the test solution. Prepare the control solution as follows: take 2.5 mL of Standard Lead Solution in a porcelain dish, add 3 mL of aqua regia, and proceed as directed for the preparation of the test solution (not more than 25 ppm).

(4) Arsenic <1.11>—Prepare the test solution with 1.0 g of Ferrous Sulfate Hydrate according to Method 1, and perform the test (not more than 2 ppm).

Assay Dissolve about 0.7 g of Ferrous Sulfate Hydrate, accurately weighed, in a mixture of 20 mL of water and 20 mL of dilute sulfuric acid, add 2 mL of phosphoric acid, and immediately titrate <2.50> with 0.02 mol/L potassium permanganate VS.

Each mL of 0.02 mol/L potassium permanganate VS
= 27.80 mg of $FeSO_4 \cdot 7H_2O$

Containers and storage Containers—Tight containers.

Fexofenadine Hydrochloride

フェキソフェナジン塩酸塩

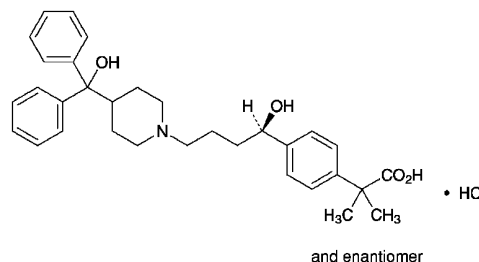

$C_{32}H_{39}NO_4 \cdot HCl$: 538.12

2-(4-((1*R,S*)-1-Hydroxy-4-[4-(hydroxydiphenylmethyl)piperidin-1-yl]butyl)phenyl)-2-methylpropanoic acid monohydrochloride [153439-40-8]

Fexofenadine Hydrochloride contains not less than 98.0% and not more than 102.0% of fexofenadine hydrochloride ($C_{32}H_{39}NO_4 \cdot HCl$), calculated on the anhydrous basis.

Description Fexofenadine Hydrochloride occurs as a white crystalline powder.

It is very soluble in methanol, soluble in ethanol (99.5), and slightly soluble in water.

A solution of Fexofenadine Hydrochloride in methanol (3 in 100) shows no optical rotation.

Fexofenadine Hydrochloride shows crystal polymorphism.

Identification (1) Determine the absorption spectrum of a solution of Fexofenadine Hydrochloride in methanol (1 in 2500) as directed under Ultraviolet-visible Spectrophotometry <2.24>, and compare the spectrum with the Reference Spectrum or the spectrum of a solution of Fexofenadine Hydrochloride RS prepared in the same manner as the sample solution: both spectra exhibit similar intensities of absorption at the same wavelengths.

(2) Determine the infrared absorption spectrum of Fexofenadine Hydrochloride as directed in the potassium bromide disk method under Infrared Spectrophotometry <2.25>, and compare the spectrum with the Reference Spectrum or the spectrum of Fexofenadine Hydrochloride RS: both spectra exhibit similar intensities of absorption at the same wave numbers. If any difference appears between the spectra, recrystallize the sample and the RS according to the method otherwise specified, filter and dry the crystals, and perform the test with the crystals.

(3) A solution of Fexofenadine Hydrochloride in a mixture of water and methanol (1:1) (3 in 200) responds to Qualitative Tests <1.09> (2) for chloride.

Purity (1) Heavy metals <1.07>—Proceed with 2.0 g of Fexofenadine Hydrochloride according to Method 4, and perform the test. Prepare the control solution with 2.0 mL of Standard Lead Solution (not more than 10 ppm).

(2) Related substances—Dissolve 7.51 g of sodium dihydrogen phosphate dihydrate and 0.84 g of sodium perchlorate in 1000 mL of water, and adjust to pH 2.0 with phosphoric acid. In a mixture of this solution and acetonitrile for liquid chromatography (1:1) dissolve 25 mg of Fexofenadine Hydrochloride to make 25 mL, and use this solution as the sample solution. Pipet 1 mL of the sample solution, and add the mobile phase to make exactly 100 mL. Pipet 1 mL of this solution, add the mobile phase to make exactly 10 mL, and use this solution as the standard solution. Perform the test with exactly 20 μ L each of the sample solution and standard solution as directed under Liquid Chromatography <2.01> according to the following conditions, and determine each peak area of both solutions by the automatic integration method: the area of the peak other than fexofenadine obtained from the sample solution is not larger than the peak area of fexofenadine from the standard solution. For the areas of the peaks, having the relative retention time of about 1.8 and about 3.3 to fexofenadine, multiply their correction factor, 1.5 and 0.9, respectively.

Operating conditions—

Detector, column, column temperature, mobile phase, and flow rate: Proceed as directed in the operating conditions in the Assay.

Time span of measurement: About 6 times as long as the retention time of fexofenadine, beginning after the solvent peak.

System suitability—

System performance: When the procedure is run with 20 μ L of the standard solution under the above operating conditions, the number of theoretical plates and the symmetry factor of the peak of fexofenadine are not less than 8000 and not more than 2.0, respectively.

System repeatability: When the test is repeated 6 times with 20 μ L of the standard solution under the above operating conditions, the relative standard deviation of the peak area of fexofenadine is not more than 2.0%.

Water <2.48> Not more than 0.5% (0.25 g, coulometric titration).

Residue on ignition <2.44> Not more than 0.1% (1 g).

Assay Dissolve 7.51 g of sodium dihydrogen phosphate dihydrate and 0.84 g of sodium perchlorate in 1000 mL of water, and adjust to pH 2.0 with phosphoric acid. In a mixture of this solution and acetonitrile for liquid chromatography (1:1) dissolve accurately weighed about 25 mg each of Fexofenadine Hydrochloride and Fexofenadine Hydrochloride RS (separately determine the water <2.48> in the same manner as Fexofenadine Hydrochloride), to make exactly 25 mL each. Pipet 3 mL each of these solutions, add the mobile phase to make exactly 50 mL, and use these solutions as the sample solution and the standard solution, respectively. Perform the test with exactly 20 μ L each of the sample solution and standard solution as directed under Liquid Chromatography <2.01> according to the following conditions, and determine the peak areas, A_T and A_S , of fexofenadine in each solution.

$$\begin{aligned} & \text{Amount (mg) of fexofenadine hydrochloride} \\ & (\text{C}_{32}\text{H}_{39}\text{NO}_4\cdot\text{HCl}) \\ & = M_S \times A_T/A_S \end{aligned}$$

M_S : Amount (mg) of Fexofenadine Hydrochloride RS

taken, calculated on the anhydrous basis

Operating conditions—

Detector: An ultraviolet absorption photometer (wavelength: 220 nm).

Column: A stainless steel column 4.6 mm in inside diameter and 25 cm in length, packed with phenylated silica gel for liquid chromatography (5 μ m in particle diameter).

Column temperature: A constant temperature of about 25°C.

Mobile phase: To 650 mL of a solution, prepared by dissolving 7.51 g of sodium dihydrogen phosphate dihydrate and 0.84 g of sodium perchlorate in 1000 mL of water and adjusting to pH 2.0 with phosphoric acid, add 350 mL of acetonitrile for liquid chromatography and 3 mL of triethylamine.

Flow rate: Adjust so that the retention time of fexofenadine is about 9 minutes.

System suitability—

System performance: When the procedure is run with 20 μ L of the standard solution under the above operating conditions, the number of theoretical plates and the symmetry factor of the peak of fexofenadine are not less than 8000 and not more than 2.0, respectively.

System repeatability: When the test is repeated 6 times with 20 μ L of the standard solution under the above operating conditions, the relative standard deviation of the peak area of fexofenadine is not more than 1.0%.

Containers and storage Containers—Well-closed containers.

Fexofenadine Hydrochloride Tablets

フェキソフェナジン塩酸塩錠

Fexofenadine Hydrochloride Tablets contain not less than 95.0% and not more than 105.0% of the labeled amount of fexofenadine hydrochloride ($\text{C}_{32}\text{H}_{39}\text{NO}_4\cdot\text{HCl}$; 538.12).

Method of preparation Prepare as directed under Tablets, with Fexofenadine Hydrochloride.

Identification To an amount of powdered Fexofenadine Hydrochloride Tablets, equivalent to 40 mg of Fexofenadine Hydrochloride, add 100 mL of methanol, and shake well. Filter, discard the first 10 mL of the filtrate, and determine the absorption spectrum of the subsequent filtrate as directed under Ultraviolet-visible Spectrophotometry <2.24>: it exhibits a maximum between 257 nm and 261 nm.

Uniformity of dosage units <6.02> Perform the Mass variation test, or the Content uniformity test according to the following method: it meets the requirement.

To 1 tablet of Fexofenadine Hydrochloride Tablets add $V/5$ mL of diluted acetic acid (100) (17 in 10,000), shake until the tablet is disintegrated. Add $3V/5$ mL of acetonitrile for liquid chromatography, shake well, add a mixture of acetonitrile for liquid chromatography and diluted acetic acid (100) (17 in 10,000) (3:1) to make exactly V mL so that each mL contains about 0.3 mg of fexofenadine hydrochloride ($\text{C}_{32}\text{H}_{39}\text{NO}_4\cdot\text{HCl}$). Pipet 5 mL of this solution, add the mobile phase to make exactly 100 mL, and filter this solution through a membrane filter with a pore size not exceeding 0.45 μ m. Discard the first 2 mL of the filtrate, and use the

subsequent filtrate as the sample solution. Separately, weigh accurately about 50 mg of Fexofenadine Hydrochloride RS (separately determine the water <2.48> in the same manner as Fexofenadine Hydrochloride), and dissolve in a mixture of acetonitrile for liquid chromatography and diluted acetic acid (100) (17 in 10,000) (3:1) to make exactly 200 mL. Pipet 6 mL of this solution, add the mobile phase to make exactly 100 mL, and use this solution as the standard solution. Then, proceed as directed in the Assay.

$$\begin{aligned} & \text{Amount (mg) of fexofenadine hydrochloride} \\ & (\text{C}_{32}\text{H}_{39}\text{NO}_4\cdot\text{HCl}) \\ & = M_S \times A_T/A_S \times 3V/500 \end{aligned}$$

M_S : Amount (mg) of Fexofenadine Hydrochloride RS taken, calculated on the anhydrous basis

Dissolution <6.10> When the test is performed at 50 revolutions per minute according to the Paddle method, using 900 mL of water as the dissolution medium, the dissolution rate in 30 minutes of Fexofenadine Hydrochloride Tablets is not less than 80%.

Start the test with 1 tablet of Fexofenadine Hydrochloride Tablets, withdraw not less than 20 mL of the medium at the specified minute after starting the test, and filter through a membrane filter with a pore size not exceeding 0.45 μm . Discard not less than 10 mL of the first filtrate, pipet V' mL of the subsequent filtrate, add water to make exactly V' mL so that each mL contains about 30 μg of fexofenadine hydrochloride ($\text{C}_{32}\text{H}_{39}\text{NO}_4\cdot\text{HCl}$), and use this solution as the sample solution. Separately, weigh accurately about 30 mg of Fexofenadine Hydrate RS (separately determine the water <2.48> in the same manner as Fexofenadine Hydrochloride), dissolve in 5 mL of methanol, add water to make exactly 100 mL. Pipet 5 mL of this solution, and add water to make exactly 50 mL, and use this solution as the standard solution. Perform the test with exactly 50 μL each of the sample solution and standard solution as directed under Liquid Chromatography <2.01> according to the following conditions, and determine the peak areas, A_T and A_S , of fexofenadine in each solution.

$$\begin{aligned} & \text{Dissolution rate (\%)} \text{ with respect to the labeled amount} \\ & \text{of fexofenadine hydrochloride } (\text{C}_{32}\text{H}_{39}\text{NO}_4\cdot\text{HCl}) \\ & = M_S \times A_T/A_S \times V'/V \times 1/C \times 90 \end{aligned}$$

M_S : Amount (mg) of Fexofenadine Hydrochloride RS taken, calculated on the anhydrous basis

C : Labeled amount (mg) of fexofenadine hydrochloride ($\text{C}_{32}\text{H}_{39}\text{NO}_4\cdot\text{HCl}$) in 1 tablet

Operating conditions—

Detector: An ultraviolet absorption photometer (wavelength: 220 nm).

Column: A stainless steel column 4.6 mm in inside diameter and 10 cm in length, packed with octadecylsilanized silica gel for liquid chromatography (5 μm in particle diameter).

Column temperature: A constant temperature of about 25°C.

Mobile phase: Dissolve 1.1 g of sodium dihydrogen phosphate dihydrate, 0.3 mL of phosphoric acid and 0.5 g of sodium perchlorate in 300 mL of water, add 700 mL of acetonitrile for liquid chromatography.

Flow rate: Adjust so that the retention time of fexofenadine is about 3.5 minutes.

System suitability—

System performance: When the procedure is run with 50 μL of the standard solution under the above operating conditions, the number of theoretical plates and the symmetry factor of the peak of fexofenadine are not less than 3000 and

not more than 2.0, respectively.

System repeatability: When the test is repeated 6 times with 50 μL of the standard solution under the above operating conditions, the relative standard deviation of the peak area of fexofenadine is not more than 2.0%.

Assay To 20 Fexofenadine Hydrochloride Tablets add $V/5$ mL of diluted acetic acid (100) (17 in 10,000), and shake until the tablets are disintegrated. Then, add $3V/5$ mL of acetonitrile for liquid chromatography, shake well, and add a mixture of acetonitrile for liquid chromatography and diluted acetic acid (100) (17 in 10,000) (3:1) to make exactly V mL so that each mL contains about 1.2 mg of fexofenadine hydrochloride ($\text{C}_{32}\text{H}_{39}\text{NO}_4\cdot\text{HCl}$). Pipet 15 mL of this solution, and add the mobile phase to make exactly 50 mL. Pipet 5 mL of this solution, add the mobile phase to make exactly 100 mL, and filter through a membrane filter with a pore size not exceeding 0.45 μm . Discard the first 2 mL of the filtrate, and use the subsequent filtrate as the sample solution. Separately, weigh accurately about 45 mg of Fexofenadine Hydrochloride RS (separately determine the water <2.48> in the same manner as Fexofenadine Hydrochloride), and dissolve in a mixture of acetonitrile for liquid chromatography and diluted acetic acid (100) (17 in 10,000) (3:1) to make exactly 200 mL. Pipet 20 mL of this solution, add the mobile phase to make exactly 250 mL, and use this solution as the standard solution. Perform the test with exactly 20 μL each of the sample solution and standard solution as directed under Liquid Chromatography <2.01> according to the following conditions, and determine the peak areas, A_T and A_S , of fexofenadine in each solution.

$$\begin{aligned} & \text{Amount (mg) of fexofenadine hydrochloride} \\ & (\text{C}_{32}\text{H}_{39}\text{NO}_4\cdot\text{HCl}) \text{ in 1 tablet} \\ & = M_S \times A_T/A_S \times V/750 \end{aligned}$$

M_S : Amount (mg) of Fexofenadine Hydrochloride RS taken, calculated on the anhydrous basis

Operating conditions—

Detector: An ultraviolet absorption photometer (wavelength: 220 nm).

Column: A stainless steel column 4.6 mm in inside diameter and 25 cm in length, packed with phenylated silica gel for liquid chromatography (5 μm in particle diameter).

Column temperature: A constant temperature of about 35°C.

Mobile phase: To 1000 mL of diluted acetic acid (100) (17 in 10,000) add 15 mL of a mixture of triethylamine and acetonitrile for liquid chromatography (1:1), and adjust to pH 5.25 with phosphoric acid. To 16 volumes of this solution add 9 volumes of acetonitrile for liquid chromatography.

Flow rate: Adjust so that the retention time of fexofenadine is about 6 minutes.

System suitability—

System performance: When the procedure is run with 20 μL of the standard solution under the above operating conditions, the number of theoretical plates and the symmetry factor of the peak of fexofenadine are not less than 7000 and not more than 2.0, respectively.

System repeatability: When the test is repeated 6 times with 20 μL of the standard solution under the above operating conditions, the relative standard deviation of the peak area of fexofenadine is not more than 1.0%.

Containers and storage Containers—Tight containers.

Filgrastim (Genetical Recombination)

フィルグラスチム(遺伝子組換え)

MTPLGPASSL PQSFLKCLE QVRKIQGDGA ALQEKLCATY KLCHPEELVL
LGHSLGIPWA PLSSCPSQAL QLAGCLSQLH SGLFLYQGLL QALEGISPEL
GPTLDTLQLD VADFATTIQ QMEELGMAPA LQPTQGAMPA FASAFQRRAG
GVLVASHLQS FLEVSRYRVLRL HLAQP

C₈₄₅H₁₃₃₉N₂₂₃O₂₄₃S₉: 18798.61
[121181-53-1]

Filgrastim (Genetical Recombination) is an aqueous solution in which a desired product is a recombinant *N*-methionyl human granulocyte colony-stimulating factor consisting of 175 amino acid residues.

It contains not less than 0.45 mg and not more than 0.55 mg of protein per mL, and not less than 1.0 × 10⁸ units per mg of protein.

Description Filgrastim (Genetical Recombination) occurs as a clear and colorless liquid.

Identification (1) Take a volume of Filgrastim (Genetical Recombination), equivalent to 5 to 10 μg of protein depending on the size of polyacrylamide gel for filgrastim, and add 10 μL of water. To 3 volumes of this solution add 1 volume of buffer solution for filgrastim sample, and use this solution as the sample solution. Separately, take a volume of Filgrastim RS which contains equal amount of protein to Filgrastim (Genetical Recombination) used above, proceed as directed for the sample solution, and use the solution so obtained as the standard solution. Set a polyacrylamide gel for filgrastim up to the electrophoresis apparatus, and put a necessary amount of buffer solution for SDS-polyacrylamide gel electrophoresis in the upper and lower reservoirs. Pipet the all amount of the sample solution and standard solution into each well of the gel, and start the electrophoresis setting the electrode of the lower reservoir as the anode. Stop the electrophoresis when the bromophenol blue band has been migrated to about the lower end of the gel. When stain the gel with a staining solution, which is prepared by dissolving 1.25 g of Coomassie brilliant blue R250 in a mixture of 450 mL of methanol, 100 mL of acetic acid (100) and water to make 1000 mL, stained bands obtained from the sample solution appear as similar migrating image at the same position as those from the standard solution.

(2) Take a volume of Filgrastim (Genetical Recombination) and Filgrastim RS, equivalent to about 80 μg of protein, add 200 μL of the buffer solution for enzyme digestion, and add water to make 390 μL. To each of these solution add 10 μL of a solution containing 50 μg of V8 protease in 250 μL of water, incubate at 25°C for 17 to 19 hours, then add 18 μL of a mixture of water and trifluoroacetic acid (19:1) to stop the reaction, and use these solutions as the sample solution and the standard solution, respectively. Perform the test with 70 μL each of the sample solution and standard solution as directed under Liquid Chromatography <2.01> according to the following conditions. When the chromatograms obtained from these solutions are compared, both chromatograms show the similar peaks at the same retention time.

Operating conditions—

Detector: An ultraviolet absorption photometer (wave-

length: 214 nm).

Column: A stainless steel column 2.1 mm in inside diameter and 25 cm in length, packed with butylsilylated silica gel for liquid chromatography (5 μm in particle diameter).

Column temperature: A constant temperature of about 40°C.

Mobile phase A: A mixture of water and trifluoroacetic acid (1000:1).

Mobile phase B: A mixture of acetonitrile, water and trifluoroacetic acid (9000:1000:9).

Flowing of mobile phase: Control the gradient by mixing the mobile phases A and B as directed in the following table.

Time after injection of sample (min)	Mobile phase A (vol%)	Mobile phase B (vol%)
0 - 2	98	2
2 - 30	98 → 70	2 → 30
30 - 85	70 → 50	30 → 50
85 - 90	50 → 2	50 → 98
90 - 100	2	98

Flow rate: 0.20 mL per minute.

System suitability—

System performance: When the procedure is run with 70 μL of the standard solution under the above operating conditions, the resolutions between each adjacent peakpair of the major 8 peaks, which are eluted after the solvent peak appeared within 10 minutes, are not less than 1.5.

pH <2.54> 3.7 - 4.3

Purity (1) Multimers—Perform the test with 250 μL of Filgrastim (Genetical Recombination) as directed under Liquid Chromatography <2.01> according to the following conditions, and determine each peak area by the automatic integration method. Calculate their amounts of the peaks by the area percentage method; the total amount of the peaks other than filgrastim is not more than 2%.

Operating conditions—

Detector: An ultraviolet absorption photometer (wavelength: 280 nm).

Column: A stainless steel column 7.5 mm in inside diameter and 60 cm in length, packed with hydrophilic silica gel for liquid chromatography.

Column temperature: A constant temperature of about 25°C.

Mobile phase: Dissolve 5.8 g of sodium chloride in 10 mL of dilute acetic acid and 900 mL of water, adjust to pH 5.5 with sodium hydroxide TS, then add 250 mg of sodium lauryl sulfate, and add water to make 1000 mL.

Flow rate: Adjust so that the retention time of filgrastim is about 17 minutes.

Time span of measurement: From the retention time corresponding to the exclusion volume of the size-exclusion column to the time when the elution of filgrastim is completed.

System suitability—

Test for required detectability: Measure exactly 10 μL of Filgrastim (Genetical Recombination), and add the mobile phase to make exactly 1000 μL. Confirm that the peak area of filgrastim obtained with 250 μL of this solution is 0.7 to 1.3% of that with 250 μL of Filgrastim (Genetical Recombination).

System performance: When the procedure is run with 10 μL of a solution containing 12.5 mg of egg albumin and 12.5 mg of myoglobin in 5 mL of water under the above operat-

ing conditions, egg albumin and myoglobin are eluted in this order with the resolution between these peaks being not less than 1.7.

System repeatability: When the test is repeated 6 times with 250 μL of Filgrastim (Genetical Recombination) under the above operating conditions, the relative standard deviation of the peak area of filgrastim is not more than 2.5%.

(2) Charge isomer—Perform the test with 100 μL of Filgrastim (Genetical Recombination) as directed under Liquid Chromatography <2.01> according to the following conditions, and determine the each peak area by the automatic integration method. Calculate their amounts of the peaks by the area percentage method; the amount of charge isomer, having the relative retention time of about 0.87 to filgrastim, is not more than 3%.

Operating conditions—

Detector: An ultraviolet absorption photometer (wavelength: 280 nm).

Column: A stainless steel column 4.6 mm in inside diameter and 35 mm in length, packed with strongly acidic ion-exchange non-porous resin for liquid chromatography (2.5 μm in particle diameter).

Column temperature: A constant temperature of about 25°C.

Mobile phase A: To 900 mL of water add 1.14 mL of acetic acid (100), adjust to pH 5.4 with sodium hydroxide TS, and add water to make 1000 mL.

Mobile phase B: Dissolve 5.84 g of sodium chloride in 1.14 mL of acetic acid (100) and 900 mL of water, adjust to pH 5.4 with sodium hydroxide TS, and add water to make 1000 mL.

Flowing of mobile phase: Control the gradient by mixing the mobile phases A and B as directed in the following table.

Time after injection of sample (min)	Mobile phase A (vol%)	Mobile phase B (vol%)
0 - 2	100	0
2 - 10	100 → 40	0 → 60
10 - 11	40 → 100	60 → 0
11 - 20	100	0

Flow rate: Adjust so that the retention time of filgrastim is about 14 minutes.

Time span of measurement: From 6 minutes to 17 minutes.

System suitability—

Test for required detectability: Confirm that when perform the test with 100 μL of the system suitability test solution for filgrastim under the above operating conditions, the content of charge isomer is between 1.4 to 2.6%.

System performance: When the procedure is run with 100 μL of the system suitability test solution for filgrastim under the above operating conditions, charge isomer peak and filgrastim are eluted in this order with the resolution between these peaks being not less than 1.5.

System repeatability: When the test is repeated 6 times with 100 μL of Filgrastim (Genetical Recombination) under the above operating conditions, the relative standard deviation of the peak area of filgrastim is not more than 2.5%.

(3) Host cell proteins—Being specified separately when the drug is granted approval based on the Law.

(4) Host cell DNA—Being specified separately when the drug is granted approval based on the Law.

Bacterial endotoxins <4.01> Less than 0.25 EU/mL.

Assay (1) Protein content—Perform the test with exactly 200 μL each of Filgrastim (Genetical Recombination) and Filgrastim RS as directed under Liquid Chromatography <2.01> according to the following conditions, and determine the peak areas, A_T and A_S , of filgrastim.

$$\begin{aligned} &\text{Amount (mg) of protein in 1 mL of Filgrastim} \\ &\text{(Genetical Recombination)} \\ &= C \times A_T/A_S \end{aligned}$$

C: Protein concentration (mg/mL) of Filgrastim RS

Operating conditions—

Detector: An ultraviolet absorption photometer (wavelength: 280 nm).

Column: A stainless steel column 4.6 mm in inside diameter and 25 cm in length, packed with octylsilanized silica gel for liquid chromatography (10 μm in particle diameter).

Column temperature: A constant temperature of about 25°C.

Mobile phase A: A mixture of water, 1-propanol and trifluoroacetic acid (699:300:1).

Mobile phase B: A mixture of 1-propanol, water and trifluoroacetic acid (800:199:1).

Flowing of mobile phase: Control the gradient by mixing the mobile phases A and B as directed in the following table.

Time after injection of sample (min)	Mobile phase A (vol%)	Mobile phase B (vol%)
0 - 2	90	10
2 - 13	90 → 70	10 → 30
13 - 15	70 → 0	30 → 100
15 - 18	0	100

Flow rate: Adjust so that the retention time of filgrastim is about 15 minutes.

System suitability—

System performance: When the procedure is run with 200 μL of a solution prepared by dissolving 1 mg of uracil and 2 mg of diphenyl in 100 mL of a mixture of water, 1-propanol and trifluoroacetic acid (649:350:1) under the above operating conditions, uracil and diphenyl are eluted in this order with the resolution between these peaks being not less than 8.

System repeatability: When the test is repeated 6 times with 200 μL of Filgrastim RS under the above operating conditions, the relative standard deviation of the peak area of filgrastim is not more than 2.5%.

(2) Specific activity—

(i) Test cell: 32D clone3 cell.

(ii) Sample dilution solution for assay: To Iscove's modified Dulbecco's fluid medium for filgrastim add 200 mmol/L L-glutamine solution and fetal calf serum to make 1 vol% and 5 vol% solution, respectively, and sterilize by filtration.

(iii) Standard solutions Dilute Filgrastim RS by the sample dilution solution for assay to prepare not less than 5 serial dilutions started from any concentration S_H so that all of their protein concentrations are within the range of 0.5 to 6 ng/mL, and use them as the standard solutions.

(iv) Sample solutions Dilute Filgrastim (Genetical Recombination) by the sample dilution solution for assay to prepare not less than 5 serial dilutions in equal ratio started from any concentration U_H so that all of their protein concentrations are within the range of 0.5 to 6 ng/mL, and use them as the sample solutions.

(v) Procedure The procedure before stopping the incubation should be performed under aseptic condition.

Transfer exactly 100 μL of each concentration of the standard solutions and sample solutions to the wells of 96-well flat bottom microplates. Not less than three plates are prepared for both standard solutions and sample solutions. Add exactly 100 μL of a test cell suspension containing 1×10^5 cells per mL in the sample dilution solution for assay to each well, and incubate under atmosphere of 5% carbon dioxide at $37 \pm 2^\circ\text{C}$ for 21 to 27 hours. After incubation, add 40 μL of fluorogenic substrate TS to each well, incubate under the same conditions as above for 21 to 51 hours, and measure fluorescence intensities at excitation wavelength 530 to 560 nm and at measurement wavelength 590 nm, using fluorescence microplate reader. Use the data from at least 3 plates and not less than 3 concentrations of the standard solution and sample solution for the calculation.

(vi) Calculation Transform each concentration of the sample solutions and standard solutions to common logarithm, and name them as x_U and x_S , respectively, and their totals are named as X_U and X_S , respectively. The fluorescence intensities obtained from the sample solution and the standard solution are named as y_U and y_S , and their totals are named as Y_U and Y_S , respectively. The numbers of the concentrations of the sample solution and the standard solution are named as n_U and n_S , respectively, the number of the plate is r . Calculate the specific activity of Filgrastim (Genetical Recombination) by the following equation, using the protein content (mg/mL) obtained in (1).

Specific activity (unit/mg) of Filgrastim (Genetical Recombination)

$$= \text{antilog } M \times \text{biological activity of Filgrastim RS} \\ (\text{unit/mL}) \times \frac{\text{dilution factor for } U_H \times \frac{U_H}{S_H}}{\text{dilution factor for } S_H \times \frac{U_H}{S_H}} \\ \times \frac{1}{\text{protein content (mg/mL) obtained in the Assay (1)}}$$

$$M = X_S/n_S - X_U/n_U - (\Sigma Y_S/n_S r - \Sigma Y_U/n_U r)/b \\ b = (Sx y_S + Sx y_U)/(Sxx_S + Sxx_U) \\ Sx y_S = \Sigma x_S Y_S - X_S \Sigma Y_S/n_S \\ Sx y_U = \Sigma x_U Y_U - X_U \Sigma Y_U/n_U \\ Sxx_S = r \Sigma x_S^2 - r X_S^2/n_S \\ Sxx_U = r \Sigma x_U^2 - r X_U^2/n_U$$

The necessary requirements for validity of the test are following three items:

1) F'_S is not less than F_1 against $m = n_S(r - 1)$ shown in the table below, and F'_U is not less than F_1 against $m = n_U(r - 1)$ shown in the table.

$$F'_S = V_{RS}/V_{ES} \\ V_{RS} = Sx y_S^2/Sxx_S \\ V_{ES} = \{\Sigma y_S^2 - \Sigma(Y_S^2/r)\}/\{n_S(r - 1)\} \\ F'_U = V_{RU}/V_{EU} \\ V_{RU} = Sx y_U^2/Sxx_U \\ V_{EU} = \{\Sigma y_U^2 - \Sigma(Y_U^2/r)\}/\{n_U(r - 1)\}$$

2) F' is smaller than F_1 against $m = (n_S + n_U)(r - 1)$ shown in the table below.

$$F' = V_P/V_E \\ V_P = Sx y_S^2/Sxx_S + Sx y_U^2/Sxx_U - (Sx y_S + Sx y_U)^2/(Sxx_S + Sxx_U) \\ V_E = \{\Sigma y_S^2 + \Sigma y_U^2 - \Sigma(Y_S^2/r) - \Sigma(Y_U^2/r)\}/\{n_S + n_U(r - 1)\}$$

3) $L \leq 0.3$

$$L = 2/b(1 - g)\sqrt{V_E F_1 \{(1 - g)(1/n_S r + 1/n_U r) + (\Sigma Y_S/n_S r - \Sigma Y_U/n_U r)^2/b^2(Sxx_S + Sxx_U)\}}$$

F_1 : Value against $m = (n_S + n_U)(r - 1)$ shown in the table.

$$g = V_E F_1 / b^2(Sxx_S + Sxx_U)$$

Value of F_1 against m

m	F_1	m	F_1	m	F_1
1	161.45	13	4.667	25	4.242
2	18.51	14	4.600	26	4.225
3	10.129	15	4.543	27	4.210
4	7.709	16	4.494	28	4.196
5	6.608	17	4.451	29	4.183
6	5.987	18	4.414	30	4.171
7	5.591	19	4.381	40	4.085
8	5.318	20	4.351	60	4.001
9	5.117	21	4.325	120	3.920
10	4.965	22	4.301	∞	3.841
11	4.844	23	4.279		
12	4.747	24	4.260		

Containers and storage Containers—Hermetic containers. Storage—Not exceeding 10°C , avoiding freezing.

Filgrastim (Genetical Recombination) Injection

フィルグラスチム(遺伝子組換え)注射液

Filgrastim (Genetical Recombination) Injection is an aqueous injection.

It contains not less than 90.0% and not more than 110.0% of the labeled amount of filgrastim (genetical recombination) ($\text{C}_{845}\text{H}_{1339}\text{N}_{223}\text{O}_{243}\text{S}_9$; 18798.61).

Method of preparation Prepare as directed under Injections, with Filgrastim (Genetical Recombination).

Description Filgrastim (Genetical Recombination) Injection is a clear and colorless liquid.

Identification Take a volume of Filgrastim (Genetical Recombination) Injection, equivalent to 5 to 10 μg of Filgrastim (Genetical Recombination) depending on the size of polyacrylamide gel for filgrastim, and add 0 to 16 μL of water. To 3 volumes of this solution add 1 volume of buffer solution for filgrastim sample so that each mL contains about 0.19 mg of protein, and use this solution as the sample solution. Then, proceed as directed in the Identification (1) under Filgrastim (Genetical Recombination).

Osmotic pressure ratio Being specified separately when the drug is granted approval based on the Law.

pH Being specified separately when the drug is granted approval based on the Law.

Purity Multimers—Proceed as directed in the Purity (1) under Filgrastim (Genetical Recombination) using a volume of Filgrastim (Genetical Recombination) Injection, equivalent to about 125 μg of Filgrastim (Genetical Recombination). Where, the test for required detectability and the system repeatability under the system suitability are tested using Filgrastim RS.

Bacterial endotoxins <4.01> Less than 0.25 EU/mL.

Extractable volume <6.05> It meets the requirement.

Foreign insoluble matter <6.06> Perform the test according

to Method 1: it meets the requirement.

Insoluble particulate matter <6.07> It meets the requirement.

Sterility <4.06> Perform the test according to the Membrane filtration method: it meets the requirement.

Biological activity Calculate the biological activity in 1 ampoule or syringe of Filgrastim (Genetical Recombination) Injection by the following equation, using the biological activity in 1 mL of Filgrastim (Genetical Recombination) Injection determined as directed in the Assay (2) under Filgrastim (Genetical Recombination) and the labeled volume of Filgrastim (Genetical Recombination) Injection: it is not less than 70% and not more than 140% of the target biological activity (unit).

Biological activity (unit) in 1 ampoule or syringe of Filgrastim (Genetical Recombination) Injection

$$= \text{antilog } M \times \text{biological activity (unit/mL) of Filgrastim RS} \times \text{dilution factor for } U_H / \text{dilution factor for } S_H \times U_H / S_H \times \text{labeled volume (mL) of Filgrastim (Genetical Recombination) Injection}$$

where, the target biological activity (unit) is calculated by the following formula.

$$\begin{aligned} \text{Target biological activity (unit)} \\ &= 1.5 \times 10^8 \text{ (unit/mg)} \times \text{labeled amount (mg) of Filgrastim (Genetical Recombination) in labeled volume (mL)} \end{aligned}$$

Assay Perform the test with an exact volume each of Filgrastim (Genetical Recombination) Injection and Filgrastim RS, equivalent to about 100 μg of Filgrastim (Genetical Recombination), as directed in the Assay (1) under Filgrastim (Genetical Recombination).

Calculate the amount of filgrastim in 1 mL of Filgrastim (Genetical Recombination) Injection by following formula.

$$\begin{aligned} \text{Amount (mg) of filgrastim in 1 mL} \\ &= C \times A_T / A_S \times V_S / V_T \end{aligned}$$

C : Protein concentration (mg/mL) of Filgrastim RS
 V_S : Amount (μL) of Filgrastim RS taken
 V_T : Amount (μL) of Filgrastim (Genetical Recombination) Injection taken

Containers and storage Containers—Hermetic containers.
 Storage—Light-resistant, not exceeding 10°C avoiding freezing.

Flavin Adenine Dinucleotide Sodium

フラビンアデニンジヌクレオチドナトリウム

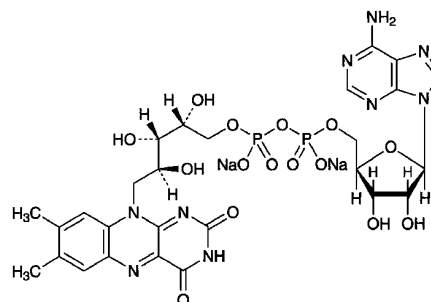

$C_{27}H_{31}N_9Na_2O_{15}P_2$: 829.51

Disodium adenosine 5'-[(2*R*,3*S*,4*S*)-5-(7,8-dimethyl-2,4-dioxo-3,4-dihydrobenzo[*g*]pteridin-10(2*H*)-yl)-2,3,4-trihydroxypentyl diphosphate]
 [84366-81-4]

Flavin Adenine Dinucleotide Sodium contains not less than 93.0% of flavin adenine dinucleotide sodium ($C_{27}H_{31}N_9Na_2O_{15}P_2$), calculated on the anhydrous basis.

Description Flavin Adenine Dinucleotide Sodium occurs as an orange-yellow to light yellow-brown powder. It is odorless or has a slight, characteristic odor, and has a slightly bitter taste.

It is freely soluble in water, and practically insoluble, in methanol, in ethanol (95), in ethyleneglycol and in diethyl ether.

It is hygroscopic.

It is decomposed by light.

Identification (1) A solution of Flavin Adenine Dinucleotide Sodium (1 in 100,000) is light yellow-green in color, and shows a strong yellow-green fluorescence. To 5 mL of the solution add 0.02 g of hydrosulfite sodium: the color and the fluorescence of the solution disappear, and gradually reappear when the solution is shaken in air. Add dilute hydrochloric acid or sodium hydroxide TS dropwise: the fluorescence of the solution disappears.

(2) Determine the infrared absorption spectrum of Flavin Adenine Dinucleotide Sodium as directed in the potassium bromide disk method under Infrared Spectrophotometry <2.25>, and compare the spectrum with the Reference Spectrum: both spectra exhibit similar intensities of absorption at the same wave numbers.

(3) To 0.1 g of Flavin Adenine Dinucleotide Sodium add 10 mL of nitric acid, evaporate on a water bath to dryness, and ignite. To the residue add 10 mL of diluted nitric acid (1 in 50), boil for 5 minutes, and after cooling, neutralize with ammonia TS, then filter the solution if necessary: the solution responds to Qualitative Tests <1.09> for sodium salt and Qualitative Tests <1.09> (1) and (3) for phosphate.

Optical rotation <2.49> $[\alpha]_D^{20}$: $-21.0 - -25.5^\circ$ (0.3 g, calculated on the anhydrous basis, water, 20 mL, 100 mm).

pH <2.54> Dissolve 1.0 g of Flavin Adenine Dinucleotide Sodium in 100 mL of water: the pH of this solution is between 5.5 and 6.5.

Purity (1) Clarity and color of solution—Dissolve 0.20 g of Flavin Adenine Dinucleotide Sodium in 10 mL of water:

the solution is clear and orange-yellow in color.

(2) Free phosphoric acid—Weigh accurately about 0.02 g of Flavin Adenine Dinucleotide Sodium, dissolve in 10 mL of water, and use this solution as the sample solution. Separately, measure exactly 2 mL of Standard Phosphoric Acid Solution, add 10 mL of water, and use this solution as the standard solution. To each of the sample solution and standard solution add 2 mL of diluted perchloric acid (100 in 117), then add 1 mL of hexaammonium heptamolybdate TS and 2 mL of 2,4-diaminophenol dihydrochloride TS, respectively, shake, add water to make exactly 25 mL, and allow to stand at $20 \pm 1^\circ\text{C}$ for 30 minutes. Perform the test with these solutions as directed under Ultraviolet-visible Spectrophotometry <2.24>, using a solution prepared in the same manner with 2 mL of water, as the blank, and determine the absorbances, A_T and A_S , of the subsequent solutions of the sample solution and the standard solution at 730 nm, respectively: the amount of free phosphoric acid is less than 0.25%.

$$\begin{aligned} \text{Amount (\%)} \text{ of free phosphoric acid (H}_3\text{PO}_4) \\ = 1/M \times A_T/A_S \times 5.16 \end{aligned}$$

M : Amount (mg) of flavin adenine dinucleotide sodium taken, calculated on the anhydrous basis

(3) Heavy metals <1.07>—Proceed with 1.0 g of Flavin Adenine Dinucleotide Sodium according to Method 2, and perform the test. Prepare the control solution with 2.0 mL of Standard Lead Solution (not more than 20 ppm).

(4) Arsenic <1.11>—Prepare the test solution with 2.0 g of Flavin Adenine Dinucleotide Sodium according to Method 3, and perform the test (not more than 1 ppm).

(5) Related substances—Dissolve 0.10 g of Flavin Adenine Dinucleotide Sodium in 200 mL of the mobile phase, and use this solution as the sample solution. Perform the test with 20 μL of the sample solution as directed under Liquid Chromatography <2.01> according to the following conditions. Determine the peak area, A , of flavin adenine dinucleotide and the total area, S , of peaks other than flavin adenine dinucleotide by the automatic integration method: $S/(A + S)$ is not more than 0.10.

Operating conditions—

Column, column temperature, mobile phase, flow rate, and time span of measurement: Proceed as directed in the operating conditions in the Procedure (ii) under the Assay (1).

Detector: An ultraviolet absorption photometer (wavelength: 260 nm).

System suitability—

System performance: Proceed as directed in the system suitability in the Procedure (ii) under the Assay (1).

Test for required detectability: To exactly 2 mL of the sample solution add the mobile phase to make exactly 20 mL, and use this solution as the solution for system suitability test. Confirm that the peak area of flavin adenine dinucleotide obtained with 20 μL of the solution for system suitability test is equivalent to 8 to 12% of that with 20 μL of the sample solution.

System repeatability: When the test is repeated 6 times with 20 μL of the solution for system suitability test under the above operating conditions, the relative standard deviation of the peak area of flavin adenine dinucleotide is not more than 1.0%.

Water <2.48> Take 50 mL of a mixture of methanol for water determination and ethyleneglycol for water determination (1:1) into a dry titration flask, and titrate with Karl Fischer TS for water determination until end point. Weigh

accurately about 0.1 g of Flavin Adenine Dinucleotide Sodium, transfer quickly to the titration flask, add an excess and constant volume of Karl Fischer TS for water determination, dissolve by stirring for 10 minutes, and perform the test: the water content is not more than 10.0%.

Assay (1) Procedure (i) Total flavin content—Conduct this procedure without exposure to light, using light-resistant vessels. Weigh accurately about 0.1 g of Flavin Adenine Dinucleotide Sodium, and dissolve in water to make exactly 200 mL. Pipet 5 mL of this solution, add 5 mL of zinc chloride TS, and heat in a water bath for 30 minutes. After cooling, add water to make exactly 100 mL, and use this solution as the sample solution. Separately, weigh accurately about 50 mg of Riboflavin RS, previously dried at 105°C for 2 hours, dissolve in 200 mL of diluted acetic acid (100) (1 in 100) by warming, cool, add water to make exactly 500 mL. Pipet 10 mL of this solution, add water to make exactly 100 mL, and use this solution as the standard solution. Determine the absorbances, A_T and A_S , of the sample solution and standard solution at 450 nm as directed under Ultraviolet-visible Spectrophotometry <2.24>, using water as the blank.

$$\text{Total amount (mg) of flavin} = M_S \times A_T/A_S \times 4/5$$

M_S : Amount (mg) of Riboflavin RS taken

(ii) Peak area ratio of flavin adenine dinucleotide—Dissolve 0.1 g of Flavin Adenine Dinucleotide Sodium in 200 mL of water, and use this solution as the sample solution. Perform the test with 5 μL of the sample solution as directed under the Liquid Chromatography <2.01> according to the following conditions. Determine the peak area, A of flavin adenine dinucleotide, and the total area, S , of the peaks other than flavin adenine dinucleotide by the automatic integration method.

$$\begin{aligned} \text{Peak area ratio of flavin adenine dinucleotide} \\ = 1.08A/(1.08A + S) \end{aligned}$$

Operating conditions—

Detector: A visible spectrophotometer (wavelength: 450 nm).

Column: A stainless steel column 4 mm in inside diameter and 15 cm in length, packed with octadecylsilanized silica gel for liquid chromatography (5 μm in particle diameter).

Column temperature: A constant temperature of about 35°C .

Mobile phase: A mixture of a solution of potassium dihydrogen phosphate (1 in 500) and methanol (4:1).

Flow rate: Adjust so that the retention time of flavin adenine dinucleotide is about 10 minutes.

Time span of measurement: About 4.5 times as long as the retention time of flavin adenine dinucleotide.

System suitability—

Test for required detectability: To exactly 2 mL of the sample solution add water to make exactly 20 mL, and use this solution as the solution for system suitability test. Pipet 2 mL of the solution for system suitability test, and add water to make exactly 20 mL. Confirm that the peak area of flavin adenine dinucleotide obtained with 5 μL of this solution is equivalent to 8 to 12% of that with 5 μL of the solution for system suitability test.

System performance: Dissolve 20 mg each of Flavin Adenine Dinucleotide Sodium and riboflavin sodium phosphate in 100 mL of water. When the procedure is run with 5 μL of this solution under the above operating conditions, flavin adenine dinucleotide and riboflavin phosphate are eluted in this order with the resolution between these peaks being not

less than 2.0.

System repeatability: When the test is repeated 6 times with 5 μ L of the solution for system suitability test under the above operating conditions, the relative standard deviation of the peak area of flavin adenine dinucleotide is not more than 1.0%.

(2) Calculation

$$\begin{aligned} & \text{Amount (mg) of flavin adenine dinucleotide sodium} \\ & (\text{C}_{27}\text{H}_{31}\text{N}_9\text{Na}_2\text{O}_{15}\text{P}_2) \\ & = f_T \times f_R \times 2.2040 \end{aligned}$$

f_T : Total amount (mg) of flavin in Flavin Adenine Dinucleotide Sodium obtained from the procedure (i)

f_R : Peak area ratio of flavin adenine dinucleotide in Flavin Adenine Dinucleotide Sodium obtained from the procedure (ii)

Containers and storage Containers—Tight containers.
Storage—Light-resistant.

Flavoxate Hydrochloride

フラボキサート塩酸塩

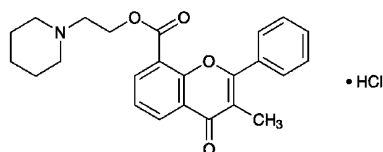

$\text{C}_{24}\text{H}_{25}\text{NO}_4 \cdot \text{HCl}$: 427.92

2-(Piperidin-1-yl)ethyl 3-methyl-4-oxo-2-phenyl-4*H*-chromene-8-carboxylate monohydrochloride
[3717-88-2]

Flavoxate Hydrochloride, when dried, contains not less than 99.0% of flavoxate hydrochloride ($\text{C}_{24}\text{H}_{25}\text{NO}_4 \cdot \text{HCl}$).

Description Flavoxate Hydrochloride occurs as white, crystals or crystalline powder.

It is sparingly soluble in acetic acid (100) and in chloroform, slightly soluble in water and in ethanol (95), and practically insoluble in acetonitrile and in diethyl ether.

Identification (1) Determine the absorption spectrum of a solution of Flavoxate Hydrochloride in 0.01 mol/L hydrochloric acid TS (1 in 50,000) as directed under Ultraviolet-visible Spectrophotometry <2.24>, and compare the spectrum with the Reference Spectrum: both spectra exhibit similar intensities of absorption at the same wavelengths.

(2) Determine the infrared absorption spectrum of Flavoxate Hydrochloride, previously dried, as directed in the potassium bromide disk method under Infrared Spectrophotometry <2.25>, and compare the spectrum with the Reference Spectrum: both spectra exhibit similar intensities of absorption at the same wave numbers.

(3) A solution of Flavoxate Hydrochloride (1 in 100) responds to Qualitative Tests <1.09> for chloride.

Purity (1) Heavy metals <1.07>—Proceed with 2.0 g of Flavoxate Hydrochloride according to Method 2, and perform the test. Prepare the control solution with 2.0 mL of Standard Lead Solution (not more than 10 ppm).

(2) Arsenic <1.11>—Prepare the test solution with 2.0 g of Flavoxate Hydrochloride according to Method 4, and perform the test (not more than 1 ppm).

(3) Related substances—Dissolve 80 mg of Flavoxate

Hydrochloride in 10 mL of chloroform, and use this solution as the sample solution. Pipet 1 mL of the sample solution, add chloroform to make exactly 20 mL, then pipet 1 mL of this solution, add chloroform to make exactly 20 mL, and use this solution as the standard solution. Perform the test with these solutions as directed under Thin-layer Chromatography <2.03>. Spot 5 μ L each of the sample solution and standard solution on a plate of silica gel with fluorescent indicator for thin-layer chromatography. Develop the plate with a mixture of 1-butanol, water and acetic acid (100) (3:1:1) to a distance of about 12 cm, and air-dry the plate. Examine under ultraviolet light (main wavelength: 254 nm): the spots other than the principal spot obtained from the sample solution are not more intense than the spot from the standard solution.

Loss on drying <2.41> Not more than 1.0% (1 g, reduced pressure, silica gel, 2 hours).

Residue on ignition <2.44> Not more than 0.1% (1 g).

Assay Weigh accurately about 0.6 g of Flavoxate Hydrochloride, previously dried, add 10 mL of acetic acid (100) and 40 mL of acetonitrile to dissolve, add 50 mL of acetic anhydride, and titrate <2.50> with 0.1 mol/L perchloric acid VS (potentiometric titration). Perform a blank determination in the same manner, and make any necessary correction.

$$\begin{aligned} & \text{Each mL of 0.1 mol/L perchloric acid VS} \\ & = 42.79 \text{ mg of } \text{C}_{24}\text{H}_{25}\text{NO}_4 \cdot \text{HCl} \end{aligned}$$

Containers and storage Containers—Tight containers.

Flecainide Acetate

フレカイニド酢酸塩

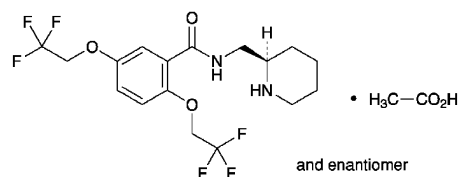

$\text{C}_{17}\text{H}_{20}\text{F}_6\text{N}_2\text{O}_3 \cdot \text{C}_2\text{H}_4\text{O}_2$: 474.39

N-[(2*RS*)-Piperidin-2-ylmethyl]-2,5-bis(2,2,2-trifluoroethoxy)benzamide monoacetate
[54143-56-5]

Flecainide Acetate, when dried, contains not less than 98.0% and not more than 101.0% of flecainide acetate ($\text{C}_{17}\text{H}_{20}\text{F}_6\text{N}_2\text{O}_3 \cdot \text{C}_2\text{H}_4\text{O}_2$).

Description Flecainide Acetate occurs as a white crystalline powder, having slightly a characteristic or acetic acid like odor.

It is freely soluble in methanol, in ethanol (95) and in acetic acid (100), and sparingly soluble in water.

A solution of Flecainide Acetate in methanol (1 in 25) shows no optical rotation.

Melting point: about 150°C (with decomposition).

Identification (1) Dissolve 20 mg of Flecainide Acetate in 1 mL of water, add 1 mL of a solution of acetaldehyde (1 in 20), and shake. To this solution add dropwise at the same time 1–2 drops each of sodium pentacyanonitrosylferrate (III) dihydrate solution (1 in 10) and sodium hydrogen carbonate TS: a blue precipitate is formed.

(2) Determine the absorption spectrum of a solution of Flecainide Acetate in ethanol (95) (13 in 100,000) as directed

under Ultraviolet-visible Spectrophotometry <2.24>, and compare the spectrum with the Reference Spectrum: both spectra exhibit similar intensities of absorption at the same wavelengths.

(3) Determine the infrared absorption spectrum of Flecainide Acetate as directed in the potassium bromide disk method under Infrared Spectrophotometry <2.25>, and compare the spectrum with the Reference Spectrum: both spectra exhibit similar intensities of absorption at the same wave numbers.

(4) Flecainide Acetate responds to Qualitative Tests <1.09> (1) for acetate.

pH <2.54> The pH of a solution of 0.5 g of Flecainide Acetate in 20 mL of water is 6.7 to 7.1.

Purity (1) Clarity and color of solution—Dissolve 0.25 g of Flecainide Acetate in 10 mL of water: the solution is clear and colorless.

(2) Heavy metals <1.07>—Transfer 1.0 g of Flecainide Acetate in a porcelain crucible, and heat gently to carbonize. After cooling, add 2 mL of sulfuric acid, heat carefully until white fumes are no longer evolved, then proceed according to Method 2 to prepare the test solution, and perform the test. Prepare the control solution as follows: Place 2 mL each of sulfuric acid and hydrochloric acid in a porcelain crucible, evaporate on a water bath, then evaporate to dryness on a sand bath, add to the residue 3 drops of hydrochloric acid, then proceed in the same manner as for the test solution, and add 2.0 mL of Standard Lead Solution and water to make 50 mL (not more than 20 ppm).

(3) 2-Aminomethylpiperidine—Dissolve exactly 0.25 g of Flecainide Acetate in exactly 5 mL of methanol, and use this solution as the sample solution. Separately, dissolve exactly 50 mg of 2-aminomethylpiperidine in methanol to make exactly 100 mL. Pipet 2 mL of this solution, add methanol to make exactly 10 mL, and use this solution as the standard solution. Perform the test with these solutions as directed under Thin-layer Chromatography <2.03>. Spot 5 μ L each of the sample solution and standard solution on a plate of silica gel for thin-layer chromatography. Develop the plate with a mixture of acetone and ammonia solution (28) (20:1) to a distance of about 10 cm, and air-dry the plate. Spray evenly a solution of ninhydrin in methanol (1 in 500), and heat at 105°C for 2 to 5 minutes: the spot obtained from the sample solution, corresponding to the spot obtained from the standard solution, is not more intense than the spot from the standard solution.

(4) Related substances—Dissolve 0.25 g of Flecainide Acetate in 25 mL of a mixture of water and acetonitrile (71:29), and use this solution as the sample solution. Pipet 1 mL of the sample solution, and add a mixture of water and acetonitrile (71:29) to make exactly 50 mL. Pipet 1 mL of this solution, add a mixture of water and acetonitrile (71:29) to make exactly 10 mL, and use this solution as the standard solution. Perform the test with exactly 20 μ L each of the sample solution and standard solution as directed under Liquid Chromatography <2.01> according to the following conditions. Determine each peak area of these solutions by the automatic integration method: the area of the peak other than flecainide obtained from the sample solution is not larger than the peak area of flecainide obtained from the standard solution, and the total area of the peaks other than flecainide from the sample solution is not larger than 2.5 times the peak area of flecainide from the standard solution. For the areas of the peaks, having the relative retention time of about 1.5 and about 2.9 to flecainide, multiply their correction factors, 0.3 and 1.7, respectively.

Operating conditions—

Detector: An ultraviolet absorption photometer (wavelength: 254 nm).

Column: A stainless steel column 4 mm in inside diameter and 15 cm in length, packed with octylsilanized silica gel for liquid chromatography (5 μ m in particle diameter).

Column temperature: A constant temperature of about 40°C.

Mobile phase: A mixture of water, acetonitrile, acetic acid (100) and tetrabutylammonium hydroxide-methanol TS (142:58:2:1), adjusted to pH 5.8 with ammonia solution (28).

Flow rate: Adjust so that the retention time of flecainide is about 4 minutes.

Time span of measurement: About 5 times as long as the retention time of flecainide, beginning after the solvent peak.

System suitability—

Test for required detectability: To exactly 1 mL of the standard solution add a mixture of water and acetonitrile (71:29) to make exactly 10 mL. Confirm that the peak area of flecainide obtained with 20 μ L of this solution is equivalent to 7 – 13% of that with 20 μ L of the standard solution.

System performance: When the procedure is run with 20 μ L of the standard solution under the above operating conditions, the number of theoretical plates and the symmetry factor of the peak of flecainide are not less than 4000 and not more than 2.0, respectively.

System repeatability: When the test is repeated 6 times with 20 μ L of the standard solution under the above operating conditions, the relative standard deviation of the peak area of flecainide is not more than 2.0%.

Loss on drying <2.41> Not more than 0.5% (1 g, reduced pressure not exceeding 0.67 kPa, 60°C, 2 hours).

Residue on ignition <2.44> Not more than 0.2% (1 g).

Assay Weigh accurately about 0.6 g of Flecainide Acetate, previously dried, dissolve in 100 mL of acetic acid (100), and titrate <2.50> with 0.1 mol/L perchloric acid VS (potentiometric titration). Perform the blank determination in the same manner, and make any necessary correction.

Each mL of 0.1 mol/L perchloric acid VS
= 47.44 mg of $C_{17}H_{20}F_6N_2O_3 \cdot C_2H_4O_2$

Containers and storage Containers—Tight containers.

Storage—Light-resistant.

Flecainide Acetate Tablets

フレカイニド酢酸塩錠

Flecainide Acetate Tablets contain not less than 93.0% and not more than 107.0% of the labeled amount of flecainide acetate ($C_{17}H_{20}F_6N_2O_3 \cdot C_2H_4O_2$: 474.39).

Method of preparation Prepare as directed under Tablets, with Flecainide Acetate.

Identification To an amount of powdered Flecainide Acetate Tablets, equivalent to 0.2 g of Flecainide Acetate, add 4 mL of methanol, shake for 20 minutes, then centrifuge and use the supernatant liquid as the sample solution. Separately, dissolve 0.1 g of flecainide acetate in 2 mL of methanol, and use this solution as the standard solution. Perform the test with these solutions as directed under Thin-layer Chromatography <2.03>. Spot 5 μ L each of the sample solution and

standard solution on a plate of silica gel with fluorescent indicator for thin-layer chromatography. Develop the plate with a mixture of acetone and ammonia solution (28) (20:1) to a distance of about 10 cm, and air-dry the plate. Examine under ultraviolet light (main wavelength: 254 nm): the principal spot obtained from the sample solution and the spot from standard solution show the same *R_f* value.

Uniformity of dosage units <6.02> Perform the Mass variation test, or the Content uniformity test according to the following method: it meets the requirement.

Completely disintegrate 1 tablet of Flecaïnide Acetate Tablets in 4*V*/5 mL of a solution of lactic acid (1 in 500) by sonicating. After allowing to stand for 30 minutes while swirling occasionally, add a solution of lactic acid (1 in 500) to make exactly *V* mL so that each mL contains about 1 mg of flecaïnide acetate (C₁₇H₂₀F₆N₂O₃·C₂H₄O₂), and filter. Discard the first 10 mL of the filtrate, pipet 5 mL of the subsequent filtrate, add a solution of lactic acid (1 in 500) to make exactly 50 mL, and use this solution as the sample solution. Then, proceed as directed in the Assay.

$$\text{Amount (mg) of flecaïnide acetate (C}_{17}\text{H}_{20}\text{F}_6\text{N}_2\text{O}_3\cdot\text{C}_2\text{H}_4\text{O}_2) = M_S \times A_T/A_S \times V/25$$

M_S: Amount (mg) of flecaïnide acetate for assay taken

Dissolution <6.10> When the test is performed at 50 revolutions per minute according to the Paddle method, using 900 mL of water as the dissolution medium, the dissolution rate in 30 minutes of Flecaïnide Acetate Tablets is not less than 70%.

Start the test with 1 tablet of Flecaïnide Acetate Tablets, withdraw not less than 20 mL of the medium at the specified minute after starting the test, and filter through a membrane filter with a pore size not exceeding 0.5 μm. Discard not less than 10 mL of the first filtrate, pipet *V* mL of the subsequent filtrate, add water to make exactly *V'* mL so that each mL contains about 56 μg of flecaïnide acetate (C₁₇H₂₀F₆N₂O₃·C₂H₄O₂), and use this solution as the sample solution. Separately, weigh accurately about 28 mg of flecaïnide acetate for assay, previously dried under reduced pressure not exceeding 0.67 kPa at 60°C for 2 hours, and dissolve in water to make exactly 50 mL. Pipet 2 mL of this solution, add water to make exactly 20 mL, and use this solution as the standard solution. Determine the absorbances, *A_T* and *A_S*, of the sample solution and standard solution at 296 nm as directed under Ultraviolet-visible Spectrophotometry <2.24>.

$$\text{Dissolution rate (\%)} \text{ with respect to the labeled amount of flecaïnide acetate (C}_{17}\text{H}_{20}\text{F}_6\text{N}_2\text{O}_3\cdot\text{C}_2\text{H}_4\text{O}_2) = M_S \times A_T/A_S \times V'/V \times 1/C \times 180$$

M_S: Amount (mg) of flecaïnide acetate for assay taken

C: Labeled amount (mg) of flecaïnide acetate (C₁₇H₂₀F₆N₂O₃·C₂H₄O₂) in 1 tablet

Assay Accurately weigh the mass of not less than 20 Flecaïnide Acetate Tablets, and powder. Weigh accurately a portion of the powder, equivalent to about 0.1 g of flecaïnide acetate (C₁₇H₂₀F₆N₂O₃·C₂H₄O₂), add 80 mL of a solution of lactic acid (1 in 500), sonicate for 5 minutes, then add a solution of lactic acid (1 in 500) to make exactly 100 mL, and filter. Discard the first 10 mL of the filtrate, pipet 5 mL of the subsequent filtrate, add a solution of lactic acid (1 in 500) to make exactly 50 mL, and use this solution as the sample solution. Separately, weigh accurately about 25 mg of flecaïnide acetate for assay, previously dried under reduced pressure not exceeding 0.67 kPa at 60°C for 2 hours, dissolve in a solution of lactic acid (1 in 500) to make

exactly 50 mL. Pipet 10 mL of this solution, add a solution of lactic acid (1 in 500) to make exactly 50 mL, and use this solution as the standard solution. Determine the absorbances, *A_T* and *A_S*, of the sample solution and standard solution at 296 nm as directed under Ultraviolet-visible Spectrophotometry <2.24>.

$$\text{Amount (mg) of flecaïnide acetate (C}_{17}\text{H}_{20}\text{F}_6\text{N}_2\text{O}_3\cdot\text{C}_2\text{H}_4\text{O}_2) = M_S \times A_T/A_S \times 4$$

M_S: Amount (mg) of flecaïnide acetate for assay taken

Containers and storage Containers—Tight containers.

Flomoxef Sodium

フロモキシセフナトリウム

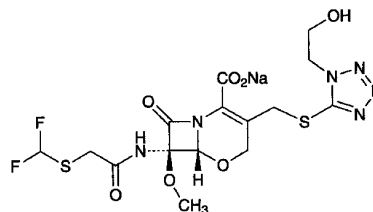

C₁₅H₁₇F₂N₆NaO₇S₂: 518.45

Monosodium (6*R*,7*R*)-7-

{[(difluoromethylsulfanyl)acetyl]amino}-3-[1-(2-hydroxyethyl)-1*H*-tetrazol-5-ylsulfanylmethyl]-7-methoxy-8-oxo-5-oxa-1-azabicyclo[4.2.0]oct-2-ene-2-carboxylate
[92823-03-5]

Flomoxef Sodium contains not less than 870 μg (potency) and not more than 985 μg (potency) per mg, calculated on the anhydrous basis. The potency of Flomoxef Sodium is expressed as mass (potency) of flomoxef (C₁₅H₁₈F₂N₆O₇S₂: 496.47).

Description Flomoxef Sodium occurs as white to light yellow-white, powder or masses.

It is very soluble in water, freely soluble in methanol, and sparingly soluble in ethanol (99.5).

Identification (1) Decompose 0.01 g of Flomoxef Sodium as directed under Oxygen Flask Combustion Method <1.06>, using a mixture of 0.5 mL of 0.01 mol/L sodium hydroxide TS and 20 mL of water as the absorbing liquid. To 2 mL of the test solution so obtained add 1.5 mL of a mixture of alizarin complexone TS, acetic acid-potassium acetate buffer solution (pH 4.3) and cerium (III) nitrate TS (1:1:1): blue-purple color develops.

(2) Determine the absorption spectrum of a solution of Flomoxef Sodium (3 in 100,000) as directed under Ultraviolet-visible Spectrophotometry <2.24>, and compare the spectrum with the Reference Spectrum: both spectra exhibit similar intensities of absorption at the same wavelengths.

(3) Determine the infrared absorption spectrum of Flomoxef Sodium as directed in the potassium bromide disk method under Infrared Spectrophotometry <2.25>, and compare the spectrum with the Reference Spectrum: both spectra exhibit similar intensities of absorption at the same wave numbers.

(4) Determine the ¹H spectrum of a solution of Flomoxef Sodium in heavy water for nuclear magnetic resonance spectroscopy (1 in 10) as directed under Nuclear Magnetic Resonance Spectroscopy <2.21>, using sodium 3-trimethyl-

silylpropanesulfonate for nuclear magnetic resonance spectroscopy as an internal reference compound: it exhibits a single signal A at around δ 3.5 ppm, a single signal or a sharp multiple signal B at around δ 3.7 ppm, and a single signal C at around δ 5.2 ppm. The ratio of the integrated intensity of these signals, A:B:C, is about 3:2:1.

(5) Flomoxef Sodium responds to Qualitative Tests <1.09> (1) for sodium salt.

Optical rotation <2.49> $[\alpha]_D^{20}$: $-8 - -13^\circ$ (1 g calculated on the anhydrous basis, a mixture of water and ethanol (99.5) (4:1), 50 mL, 100 mm).

pH <2.54> The pH of a solution obtained by dissolving 0.5 g of Flomoxef Sodium in 5 mL of water is between 4.0 and 5.5.

Purity (1) Clarity and color of solution—Dissolve 1.0 g of Flomoxef Sodium in 10 mL of water: the solution is clear and has no more color than the following control solution.

Control solution: To a mixture of 3.0 mL of Cobalt (II) Chloride CS and 12 mL of Iron (III) Chloride CS add 35 mL of diluted dilute hydrochloric acid (1 in 10). To 5.0 mL of this solution add 5.0 mL of diluted dilute hydrochloric acid (1:10).

(2) Heavy metals <1.07>—Proceed with 1.0 g of Flomoxef Sodium in a quartz crucible according to Method 2, and perform the test. Prepare the control solution with 2.0 mL of Standard Lead Solution (not more than 20 ppm).

(3) Arsenic <1.11>—To 1.0 g of Flomoxef Sodium 5 mL of sulfuric acid and 5 mL of nitric acid, heat carefully until the solution changes to colorless to light yellow with occasional addition of 2 mL of nitric acid. After cooling, add 10 mL of ammonium oxalate TS, heat until white fumes evolve, and concentrate to 2 to 3 mL. After cooling, add water to make 10 mL, and perform the test using this solution as the test solution: the color is not darker than that of the control solution.

Control solution: Proceed to prepare a solution in the same manner as the test solution without Flomoxef Sodium, and transfer 10 mL of the solution so obtained to the generator bottle, add exactly 2 mL of Standard Arsenic Solution, and proceed in the same manner as the test solution (not more than 2 ppm).

(4) 1-(2-Hydroxyethyl)-1*H*-tetrazol-5-thiol—Use the sample solution obtained in the Assay as the sample solutions. Weigh accurately about 20 mg of 1-(2-hydroxyethyl)-1*H*-tetrazol-5-thiol, and dissolve in water to make exactly 100 mL. Pipet 5 mL of this solution, add exactly 25 mL of the internal standard solution and water to make 50 mL, and use this solution as the standard solution. Perform the test with 5 μ L each of the sample solution and standard solution as directed under Liquid Chromatography <2.01> according to the following conditions, and calculate the ratios, Q_T and Q_S , of the peak area of 1-(2-hydroxyethyl)-1*H*-tetrazol-5-thiol to that of the internal standard: the amount of 1-(2-hydroxyethyl)-1*H*-tetrazol-5-thiol is not more than 1.0% of the amount of Flomoxef Sodium calculated on the anhydrous basis.

$$\begin{aligned} &\text{Amount (mg) of 1-(2-hydroxyethyl)-1H-tetrazol-5-thiol} \\ &(\text{C}_3\text{H}_6\text{N}_4\text{OS}) \\ &= M_S \times Q_T / Q_S \times 1/10 \end{aligned}$$

M_S : Amount (mg) of 1-(2-hydroxyethyl)-1*H*-tetrazol-5-thiol taken

Internal standard solution—A solution of *m*-cresol (3 in 1000).

Operating conditions—

Proceed as directed in the operating conditions in the Assay.

System suitability—

Test for required detectability: Pipet 1 mL of the standard solution, and add water to make exactly 20 mL. Confirm that the peak area of 1-(2-hydroxyethyl)-1*H*-tetrazol-5-thiol obtained with 5 μ L of this solution is equivalent to 3.5 to 6.5% of that with 5 μ L of the standard solution.

System performance: When the procedure is run with 5 μ L of the standard solution under the above operating conditions, 1-(2-hydroxyethyl)-1*H*-tetrazol-5-thiol and the internal standard are eluted in this order with the resolution between these peaks being not less than 20.

System repeatability: When the test is repeated 3 times with 5 μ L of the standard solution under the above operating conditions, the relative standard deviation of the ratio of the peak area of 1-(2-hydroxyethyl)-1*H*-tetrazol-5-thiol to that of the internal standard is not more than 1.0%.

Water <2.48> Not more than 1.5% (0.5 g, volumetric titration, back titration).

Assay Weigh accurately an amount of Flomoxef Sodium and Flomoxef Triethylammonium RS, equivalent to about 50 mg (potency), and dissolve each in exactly 50 mL of the internal standard solution, add water to make 100 mL, and use these solutions as the sample solution and standard solution. Perform the test with 5 μ L each of the sample solution and standard solution as directed under Liquid Chromatography <2.01> according to the following conditions, and calculate the ratios, Q_T and Q_S , of the peak area of flomoxef to that of the internal standard.

$$\begin{aligned} &\text{Amount } [\mu\text{g (potency)}] \text{ of flomoxef (C}_{15}\text{H}_{18}\text{F}_2\text{N}_6\text{O}_7\text{S}_2) \\ &= M_S \times Q_T / Q_S \times 1000 \end{aligned}$$

M_S : Amount [mg (potency)] of Flomoxef Triethylammonium RS taken

Internal standard solution—A solution of *m*-cresol (3 in 1000).

Operating conditions—

Detector: An ultraviolet absorption photometer (wavelength: 246 nm).

Column: A stainless steel column 4 mm in inside diameter and 20 cm in length, packed with octadecylsilylated silica gel for liquid chromatography (5 – 10 μ m in particle diameter).

Column temperature: A constant temperature of about 25°C.

Mobile phase: Dissolve 6.94 g of potassium dihydrogen phosphate, 3.22 g of disodium hydrogen phosphate dodecahydrate and 1.60 g of tetra-*n*-butylammonium bromide in water to make 1000 mL. To 750 mL of this solution add 250 mL of methanol.

Flow rate: Adjust so that the retention time of flomoxef is about 9 minutes.

System suitability—

System performance: When the procedure is run with 5 μ L of the standard solution under the above operating conditions, flomoxef and the internal standard are eluted in this order with the resolution between these peaks being not less than 10.

System repeatability: When the test is repeated 3 times with 5 μ L of the standard solution under the above operating conditions, the relative standard deviation of the ratios of the peak area of flomoxef to that of the internal standard is not more than 1.0%.

Containers and storage Containers—Tight containers.

Storage—Not exceeding 5°C.

Flomoxef Sodium for Injection

注射用フロモキセフナトリウム

Flomoxef Sodium for Injection is a preparation for injection which is dissolved before use.

It contains not less than 90.0% and not more than 110.0% of the labeled potency of flomoxef ($C_{15}H_{18}F_2N_6O_7S_2$; 496.47).

Method of preparation Prepare as directed under Injections, with Flomoxef Sodium.

Description Flomoxef Sodium for Injection occurs as white to light yellow-white, friable masses or powder.

Identification Proceed as directed in the Identification (3) under Flomoxef Sodium.

pH <2.54> The pH of a solution obtained by dissolving an amount of Flomoxef Sodium for Injection, equivalent to 0.5 g (potency) of Flomoxef Sodium, in 5 mL of water is between 4.0 and 5.5.

Purity (1) Clarity and color of solution—Dissolve an amount of Flomoxef Sodium for Injection, equivalent to 1.0 g (potency) of Flomoxef Sodium, in 10 mL of water: the solution is clear and colorless or pale yellow.

(2) 1-(2-Hydroxyethyl)-1*H*-tetrazol-5-thiol—Use the sample solution obtained in the Assay as the sample solution. Weigh accurately about 20 mg of 1-(2-hydroxyethyl)-1*H*-tetrazol-5-thiol, and dissolve in water to make exactly 100 mL. Pipet 5 mL of this solution, add exactly 25 mL of the internal standard solution and water to make 50 mL, and use this solution as the standard solution. Perform the test with 5 μ L each of the sample solution and standard solution as directed under Liquid Chromatography <2.01> according to the following conditions, and calculate the ratios, Q_T and Q_S , of the peak area of 1-(2-hydroxyethyl)-1*H*-tetrazol-5-thiol to that of the internal standard. Calculate the amount of 1-(2-hydroxyethyl)-1*H*-tetrazol-5-thiol per 1 g (potency) of Flomoxef Sodium for Injection by the following formula: not more than 10 mg.

$$\begin{aligned} &\text{Amount (mg) of 1-(2-hydroxyethyl)-1H-tetrazol-5-thiol} \\ & \quad (C_3H_6N_4OS) \\ & = M_S \times Q_T / Q_S \times 1/10 \end{aligned}$$

M_S : Amount (mg) of 1-(2-hydroxyethyl)-1*H*-tetrazol-5-thiol taken

Internal standard solution—A solution of *m*-cresol (3 in 1000).

Operating conditions—

Proceed as directed in the operating conditions in the Assay under Flomoxef Sodium.

System suitability—

Test for required detectability: Pipet 1 mL of the standard solution, and add water to make exactly 20 mL. Confirm that the peak area of 1-(2-hydroxyethyl)-1*H*-tetrazol-5-thiol obtained with 5 μ L of this solution is equivalent to 3.5–6.5% of that with 5 μ L of the standard solution.

System performance: When the procedure is run with 5 μ L of the standard solution under the above operating conditions, 1-(2-hydroxyethyl)-1*H*-tetrazol-5-thiol and the internal standard are eluted in this order with the resolution between these peaks being not less than 20.

System repeatability: When the test is repeated 3 times with 5 μ L of the standard solution under the above operating conditions, the relative standard deviation of the ratio of the peak area of 1-(2-hydroxyethyl)-1*H*-tetrazol-5-thiol to that of the internal standard is not more than 1.0%.

Water <2.48> Not more than 1.5% (0.5 g, volumetric titration, back titration).

Bacterial endotoxins <4.01> Less than 0.025 EU/mg (potency).

Uniformity of dosage units <6.02> It meets the requirement of the Mass variation test.

Foreign insoluble matter <6.06> Perform the test according to Method 2: it meets the requirement.

Insoluble particulate matter <6.07> It meets the requirement.

Sterility <4.06> Perform the test according to the Membrane filtration method: it meets the requirement.

Assay Weigh accurately the mass of the contents of not less than 10 Flomoxef Sodium for Injection, and calculate the average mass of the content. Spread out thinly about 1 g of the content in a petri dish, allow the dish to stand in a desiccator containing a saturated solution of magnesium bromide without light exposure to equilibrate the sample to constant water content. Determine the water content, separately, with about 0.1 g of the sample according to the method described in Water. Weigh accurately an amount of the sample, equivalent to about 50 mg (potency) of Flomoxef Sodium, add exactly 50 mL of the internal standard solution to dissolve, add water to make 100 mL, and use this solution as the sample solution. Separately weigh accurately about 50 mg (potency) of Flomoxef Triethylammonium RS, add exactly 50 mL of the internal standard solution to dissolve, add water to make 100 mL, and use this solution as the standard solution. Proceed as directed in the Assay under Flomoxef Sodium.

$$\begin{aligned} &\text{Amount } [\mu\text{g (potency)}] \text{ of flomoxef } (C_{15}H_{18}F_2N_6O_7S_2) \\ & = M_S \times Q_T / Q_S \times 1000 \end{aligned}$$

M_S : Amount [mg (potency)] of Flomoxef Triethylammonium RS taken

Internal standard solution—A solution of *m*-cresol (3 in 1000).

Containers and storage Containers—Hermetic containers. Plastic containers for aqueous injection may be used.

Flopropione

フロプロピオン

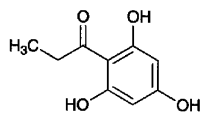

$C_9H_{10}O_4$: 182.17
1-(2,4,6-Trihydroxyphenyl)propan-1-one
[2295-58-1]

Flopropione contains not less than 98.0% and not more than 101.0% of flopropione ($C_9H_{10}O_4$), calculated on the anhydrous basis.

Description Flopropione occurs as a white to pale yellow-brown crystalline powder.

It is very soluble in *N,N*-dimethylformamide, freely soluble in methanol and in ethanol (99.5), and practically insoluble in water.

Identification (1) Determine the absorption spectrum of a solution of Flopropione in ethanol (99.5) (1 in 200,000) as directed under Ultraviolet-visible Spectrophotometry <2.24>, and compare the spectrum with the Reference Spectrum: both spectra exhibit similar intensities of absorption at the same wavelengths.

(2) Determine the infrared absorption spectrum of Flopropione as directed in the potassium bromide disk method under Infrared Spectrophotometry <2.25>, and compare the spectrum with the Reference Spectrum: both spectra exhibit similar intensities of absorption at the same wave numbers.

Melting point <2.60> 177 – 181°C

Purity (1) Heavy metals <1.07>—Proceed with 1.0 g of Flopropione according to Method 4, and perform the test. Prepare the control solution with 2.0 mL of Standard Lead Solution (not more than 20 ppm).

(2) Related substances—Dissolve 50 mg of Flopropione in 50 mL of the mobile phase, and use this solution as the sample solution. Pipet 1 mL of the sample solution, add the mobile phase to make exactly 100 mL, and use this solution as the standard solution. Perform the test with exactly 20 μ L each of the sample solution and standard solution as directed under Liquid Chromatography <2.01> according to the following conditions. Determine each peak area of both solutions by the automatic integration method: the area of each peak other than flopropione obtained from the sample solution is not larger than 1/10 times the peak area of flopropione from the standard solution.

Operating conditions—

Detector: An ultraviolet absorption photometer (wavelength: 267 nm).

Column: A stainless steel column 4.6 mm in inside diameter and 15 cm in length, packed with octadecylsilanized silica gel for liquid chromatography (5 μ m in particle diameter).

Column temperature: A constant temperature of about 35°C.

Mobile phase: A mixture of acetonitrile, water and phosphoric acid (114:86:1).

Flow rate: Adjust so that the retention time of flopropione is about 3 minutes.

Time span of measurement: About 7 times as long as the retention time of flopropione.

System suitability—

Test for required detectability: Pipet 1 mL of the standard solution, and add the mobile phase to make exactly 10 mL. Confirm that the peak area of flopropione obtained with 20 μ L of this solution is equivalent to 7 to 13% of that with from 20 μ L of the standard solution.

System performance: Dissolve 25 mg of ethyl parahydroxybenzoate in 30 mL of acetonitrile, and add the mobile phase to make 50 mL. To 2.5 mL of this solution add 2 mL of the sample solution and the mobile phase to make 50 mL. When the procedure is run with 20 μ L of this solution under the above operating conditions, flopropione and ethyl parahydroxybenzoate are eluted in this order with the resolution between these peaks being not less than 2.0.

System repeatability: When the test is repeated 6 times with 20 μ L of the standard solution under the above operating conditions, the relative standard deviation of the peak area of flopropione is not more than 1.0%.

Water <2.48> Not more than 4.0% (0.5 g, volumetric titration, direct titration).

Residue on ignition <2.44> Not more than 0.1% (1 g).

Assay Weigh accurately about 0.3 g of Flopropione, dissolve in 30 mL of *N,N*-dimethylformamide, and titrate <2.50> with 0.1 mol/L tetramethylammonium hydroxide VS (potentiometric titration). Perform a blank determination in the same manner, and make any necessary correction.

Each mL of 0.1 mol/L tetramethylammonium hydroxide VS
= 18.22 mg of $C_9H_{10}O_4$

Containers and storage Containers—Tight containers.

Storage—Light-resistant.

Flopropione Capsules

フロプロピオンカプセル

Flopropione Capsules contain not less than 93.0% and not more than 107.0% of the labeled amount of flopropione ($C_9H_{10}O_4$: 182.17).

Method of preparation Prepare as directed under the Capsules, with Flopropione.

Identification (1) Powder the contents of Flopropione Capsules. To a portion of the powder, equivalent to 60 mg of Flopropione, add 40 mL of water, shake well, and filter. To 5 mL of the filtrate add 1 mL of iron (III) nitrate TS: a red-purple color appears.

(2) Powder the contents of Flopropione Capsules. To a portion of the powder, equivalent to 90 mg of Flopropione, add 100 mL of ethanol (99.5), shake well, and filter. To 5 mL of the filtrate add ethanol (99.5) to make 50 mL. To 5 mL of this solution add ethanol (99.5) to make 100 mL, and use this solution as the sample solution. Determine the absorption spectrum of the sample solution as directed under Ultraviolet-visible Spectrophotometry <2.24>: it exhibits a maximum between 283 nm and 287 nm.

Uniformity of dosage units <6.02> Perform the test according to the following method: it meets the requirement of the Content uniformity test.

To 1 capsule of Flopropione Capsules add 43 mL of a mixture of water and phosphoric acid (86:1), and disintegrate the capsule in a water bath at 50°C. After cooling, add

a suitable amount of acetonitrile to make exactly V mL of a solution containing about 0.4 mg of flopropione ($C_9H_{10}O_4$) per mL. Stir the solution for 10 minutes, centrifuge a part of the solution at 3000 rpm for 5 minutes, and use the supernatant liquid as the sample solution. Proceed as directed in the Assay.

$$\begin{aligned} &\text{Amount (mg) of flopropione (C}_9\text{H}_{10}\text{O}_4) \\ &= M_S \times A_T/A_S \times V/100 \end{aligned}$$

M_S : Amount (mg) of flopropione for assay taken, calculated on the anhydrous basis

Dissolution <6.10> When the test is performed at 100 revolutions per minute according to the Paddle method using the sinker, using 900 mL of water as the dissolution medium, the dissolution rate in 45 minutes of Flopropione Capsules is not less than 80%.

Start the test with 1 capsule of Flopropione Capsules, withdraw not less than 20 mL of the medium at the specified minute after starting the test, and filter through a membrane filter with a pore size not exceeding 0.45 μm . Discard not less than 10 mL of the first filtrate, pipet V mL of the subsequent filtrate, add 0.1 mol/L hydrochloric acid TS to make exactly V' mL so that each mL contains about 8.8 μg of flopropione ($C_9H_{10}O_4$), and use this solution as the sample solution. Separately, weigh accurately about 22 mg of flopropione for assay (separately determine the water <2.48> in the same manner as Flopropione), and dissolve in methanol to make exactly 50 mL. Pipet 2 mL of this solution, add 0.1 mol/L hydrochloric acid TS to make exactly 100 mL, and use this solution as the standard solution. Determine the absorbances, A_T and A_S , at 284 nm of the sample solution and standard solution as directed under Ultraviolet-visible Spectrophotometry <2.24>, using 0.1 mol/L hydrochloric acid TS as the blank.

$$\begin{aligned} &\text{Dissolution rate (\%)} \text{ with respect to the labeled amount} \\ &\text{of flopropione (C}_9\text{H}_{10}\text{O}_4) \\ &= M_S \times A_T/A_S \times V'/V \times 1/C \times 36 \end{aligned}$$

M_S : Amount (mg) of flopropione for assay taken, calculated on the anhydrous basis

C : Labeled amount (mg) of flopropione ($C_9H_{10}O_4$) in 1 capsule

Assay Take out the contents of not less than 20 Flopropione Capsules, weigh accurately the mass of the contents, and power. Weigh accurately a part of the powder, equivalent to about 40 mg of flopropione ($C_9H_{10}O_4$), and add the mobile phase to make exactly 100 mL. Stir the solution for 10 minutes, centrifuge a part of this solution for 5 minutes at 3000 rpm, and use the supernatant liquid as the sample solution. Separately, weigh accurately about 40 mg of flopropione for assay (previously determine the water <2.48> in the same manner as Flopropione), add 70 mL of the mobile phase, and dissolve by sonicating for 10 minutes. Add the mobile phase to make exactly 100 mL, and use this solution as the standard solution. Perform the test with exactly 5 μL each of the sample solution and standard solution as directed under Liquid chromatography <2.01> according to the following conditions, and determine the peak areas, A_T and A_S , of flopropione in each solution.

$$\text{Amount (mg) of flopropione (C}_9\text{H}_{10}\text{O}_4) = M_S \times A_T/A_S$$

M_S : Amount (mg) of flopropione for assay taken, calculated on the anhydrous basis

Operating conditions—

Detector: An ultraviolet absorption photometer (wavelength: 267 nm).

Column: A stainless steel column 4.6 mm in inside diameter and 15 cm in length, packed with octadecylsilanized silica gel for liquid chromatography (5 μm in particle diameter).

Column temperature: A constant temperature of about 35°C.

Mobile phase: A mixture of acetonitrile, water and phosphoric acid (114:86:1).

Flow rate: Adjust so that the retention time of flopropione is about 3 minutes.

System suitability—

System performance: Dissolve 50 mg of flopropione in 50 mL of the mobile phase. To 20 mL of the solution add 25 mL of a solution prepared by dissolving 25 mg of ethyl parahydroxybenzoate in 30 mL of acetonitrile and add water to make 50 mL, and then add the mobile phase to make 50 mL. When the procedure is run with 5 μL of this solution under the above operating conditions, Flopropione and ethyl parahydroxybenzoate are eluted in this order with the resolution between these peaks being not less than 2.0.

System repeatability: When the test is repeated 6 times with 5 μL of the standard solution under the above operating conditions, the relative standard deviation of the peak area of flopropione is not more than 1.0%.

Containers and storage Containers—Tight containers.

Fluconazole

フルコナゾール

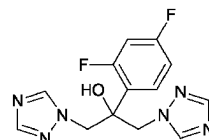

$C_{13}H_{12}F_2N_6O$: 306.27

2-(2,4-Difluorophenyl)-1,3-bis(1H-1,2,4-triazol-1-yl)propan-2-ol [86386-73-4]

Fluconazole, when dried, contains not less than 99.0% and not more than 101.0% of fluconazole ($C_{13}H_{12}F_2N_6O$).

Description Fluconazole occurs as a white to pale yellow-white crystalline powder.

It is soluble in ethanol (99.5), and slightly soluble in water.

It dissolves in dilute hydrochloric acid.

Identification (1) Dissolve 0.1 g of Fluconazole in 10 mL of dilute hydrochloric acid, and add 1 mL of Reinecke's salt TS: a light red precipitate is formed.

(2) Determine the absorption spectrum of a solution of Fluconazole in 0.01 mol/L hydrochloric acid-methanol TS (1 in 4000) as directed under Ultraviolet-visible Spectrophotometry <2.24>, and compare the spectrum with the Reference Spectrum: both spectra exhibit similar intensities of absorption at the same wavelengths.

(3) Determine the infrared absorption spectrum of Fluconazole as directed in the potassium bromide disk method under Infrared Spectrophotometry <2.25>, and compare the spectrum with the Reference Spectrum: both spectra exhibit similar intensities of absorption at the same wave numbers.

Melting point <2.60> 137 – 141°C

Purity (1) Clarity and color of solution—A solution obtained by dissolving 0.10 g of Fluconazole in 50 mL of water is clear and colorless.

(2) Heavy metals <1.07>—Proceed with 1.0 g of Fluconazole according to Method 4, and perform the test. Prepare the control solution with 2.0 mL of Standard Lead Solution (not more than 20 ppm).

(3) Related substances—Dissolve 30 mg of Fluconazole in 10 mL of the mobile phase, and use this solution as the sample solution. Pipet 1 mL of the sample solution, add the mobile phase to make exactly 100 mL. Pipet 1 mL of this solution, add the mobile phase to make exactly 10 mL, and use this solution as the standard solution. Perform the test with exactly 20 μ L each of the sample solution and standard solution as directed under Liquid Chromatography <2.01> according to the following conditions, and determine each peak area of both solutions by the automatic integration method: the peak area of related substance I, having the relative retention time about 0.60 to fluconazole obtained from the sample solution is not larger than 6 times the peak area of fluconazole from the standard solution, the area of the peak other than fluconazole and the related substance I from the sample solution is not larger than the peak area of fluconazole from the standard solution, and the total area of the peaks other than fluconazole from the sample solution is not larger than 8 times the peak area of fluconazole from the standard solution.

Operating conditions—

Detector: An ultraviolet absorption photometer (wavelength: 260 nm).

Column: A stainless steel column 4.6 mm in inside diameter and 15 cm in length, packed with octadecylsilanized silica gel for liquid chromatography (5 μ m in particle diameter).

Column temperature: A constant temperature of about 40°C.

Mobile phase: A mixture of water and acetonitrile (4:1).

Flow rate: Adjust so that the retention time of fluconazole is about 10 minutes.

Time span of measurement: About 3 times as long as the retention time of fluconazole, beginning after the solvent peak.

System suitability—

Test for required detectability: Pipet 5 mL of the standard solution, and add the mobile phase to make exactly 10 mL. Confirm that the peak area of fluconazole obtained with 20 μ L of this solution is equivalent to 35 to 65% of that with 20 μ L of the standard solution.

System performance: When the procedure is run with 20 μ L of the standard solution under the above operating conditions, the number of theoretical plates and the symmetry factor of the peak of fluconazole are not less than 4000 and not more than 2.0, respectively.

System repeatability: When the test is repeated 6 times with 20 μ L of the standard solution under the above operating conditions, the relative standard deviation of the peak area of fluconazole is not more than 2.0%.

Loss on drying <2.41> Not more than 1.0% (1 g, 105°C, 4 hours).

Residue on ignition <2.44> Not more than 0.2% (1 g).

Assay Weigh accurately about 0.25 g of Fluconazole, previously dried, dissolve in 100 mL of a mixture of acetic anhydride and acetic acid (100) (7:3), and titrate <2.50> with 0.1 mol/L perchloric acid VS (potentiometric titration). Perform the blank determination in the same manner, and make

any necessary correction.

Each mL of 0.1 mol/L perchloric acid VS
= 15.31 mg of C₁₃H₁₂F₂N₆O

Containers and storage Containers—Tight containers.

Fluconazole Capsules

フルコナゾールカプセル

Fluconazole Capsules contain not less than 93.0% and not more than 107.0% of the labeled amount of fluconazole (C₁₃H₁₂F₂N₆O: 306.27).

Method of preparation Prepare as directed under Capsules, with Fluconazole.

Identification To an amount of powdered contents of Fluconazole Capsules, equivalent to 25 mg of Fluconazole, add 0.01 mol/L hydrochloric acid-methanol TS to make 100 mL, shake for 30 minutes, and filter. Determine the absorption spectrum of the filtrate as directed under Ultraviolet-visible Spectrophotometry <2.24>: it exhibits maxima between 259 nm and 263 nm and between 265 nm and 269 nm.

Uniformity of dosage units <6.02> Perform the Mass variation test, or the Content uniformity test according to the following method: it meets the requirement.

To the total amount of the content of 1 capsule of Fluconazole Capsules add the mobile phase to make exactly 100 mL. Disperse the particles by sonicating, stir for 30 minutes, and filter through a membrane filter with a pore size not exceeding 0.45 μ m. Discard the first 10 mL of the filtrate, pipet V mL of the subsequent filtrate, add the mobile phase to make exactly V' mL so that each mL contains about 50 μ g of fluconazole (C₁₃H₁₂F₂N₆O), and use this solution as the sample solution. Then, proceed as directed in the Assay.

$$\begin{aligned} \text{Amount (mg) of fluconazole (C}_{13}\text{H}_{12}\text{F}_2\text{N}_6\text{O)} \\ = M_S \times A_T/A_S \times V'/V \times 1/5 \end{aligned}$$

M_S : Amount (mg) of fluconazole for assay taken

Dissolution <6.10> When the test is performed at 50 revolutions per minute according to the Paddle method using the sinker, using 900 mL of water as the dissolution medium, the dissolution rates in 90 minutes of 50-mg capsule and 100-mg capsule are not less than 80% and not less than 70%, respectively.

Start the test with 1 capsule of Fluconazole Capsules, withdraw not less than 20 mL of the medium at the specified minute after starting the test, and filter through a membrane filter with a pore size not exceeding 0.45 μ m. Discard not less than 10 mL of the first filtrate, pipet V mL of the subsequent filtrate, add the mobile phase to make exactly V' mL so that each mL contains about 28 μ g of fluconazole (C₁₃H₁₂F₂N₆O), and use this solution as the sample solution. Separately, weigh accurately about 28 mg of fluconazole for assay, previously dried at 105°C for 4 hours, and dissolve in the mobile phase to make exactly 50 mL. Pipet 5 mL of this solution, add the mobile phase to make exactly 100 mL, and use this solution as the standard solution. Perform the test with exactly 20 μ L each of the sample solution and standard solution as directed under Liquid Chromatography <2.01> according to the following conditions, and determine the peak areas, A_T and A_S , of fluconazole in each solution.

Dissolution rate (%) with respect to the labeled amount of fluconazole ($C_{13}H_{12}F_2N_6O$)

$$= M_S \times A_T/A_S \times V'/V \times 1/C \times 90$$

M_S : Amount (mg) of fluconazole for assay taken

C : Labeled amount (mg) of fluconazole ($C_{13}H_{12}F_2N_6O$) in 1 capsule

Operating conditions—

Proceed as directed in the operating conditions in the Assay.

System suitability—

System performance: When the procedure is run with 20 μ L of the standard solution under the above operating conditions, the number of theoretical plates and the symmetry factor of the peak of fluconazole are not less than 3000 and not more than 1.5, respectively.

System repeatability: When the test is repeated 6 times with 20 μ L of the standard solution under the above operating conditions, the relative standard deviation of the peak area of fluconazole is not more than 1.0%.

Assay Take out the contents from not less than 20 Fluconazole Capsules, weigh accurately, and powder, if necessary. Weigh accurately a quantity of the contents, equivalent to about 50 mg of fluconazole ($C_{13}H_{12}F_2N_6O$), and add the mobile phase to make exactly 100 mL. Disperse the particles by sonicating, stir for 30 minutes, and filter through a membrane filter with a pore size not exceeding 0.45 μ m. Discard the first 10 mL of the filtrate, pipet 5 mL of the subsequent filtrate, add the mobile phase to make exactly 50 mL, and use this solution as the sample solution. Separately, weigh accurately about 25 mg of fluconazole for assay, previously dried at 105°C for 4 hours, and dissolve in the mobile phase to make exactly 50 mL. Pipet 5 mL of this solution, add the mobile phase to make exactly 50 mL, and use this solution as the standard solution. Perform the test with exactly 20 μ L each of the sample solution and standard solution as directed under Liquid Chromatography <2.01> according to the following conditions, and determine the peak areas, A_T and A_S , of fluconazole in each solution.

$$\begin{aligned} &\text{Amount (mg) of fluconazole (C}_{13}\text{H}_{12}\text{F}_2\text{N}_6\text{O)} \\ &= M_S \times A_T/A_S \times 2 \end{aligned}$$

M_S : Amount (mg) of fluconazole for assay taken

Operating conditions—

Detector: An ultraviolet absorption photometer (wavelength: 261 nm).

Column: A stainless steel column 3.9 mm in inside diameter and 15 cm in length, packed with octadecylsilanized silica gel for liquid chromatography (4 μ m in particle diameter).

Column temperature: A constant temperature of about 35°C.

Mobile phase: Dissolve 0.82 g of anhydrous sodium acetate in 1000 mL of water, and adjust to pH 5.0 with acetic acid (100). To 700 mL of this solution add 200 mL of methanol and 100 mL of acetonitrile.

Flow rate: Adjust so that the retention time of fluconazole is about 4 minutes.

System suitability—

System performance: When the procedure is run with 20 μ L of the standard solution under the above operating conditions, the number of theoretical plates and the symmetry factor of the peak of fluconazole are not less than 3000 and not more than 1.5, respectively.

System repeatability: When the test is repeated 6 times with 20 μ L of the standard solution under the above operating conditions, the relative standard deviation of the peak

area of fluconazole is not more than 1.0%.

Containers and storage Containers—Tight containers.

Fluconazole Injection

フルコナゾール注射液

Fluconazole Injection is an aqueous injection.

It contains not less than 95.0% and not more than 105.0% of the labeled amount of fluconazole ($C_{13}H_{12}F_2N_6O$: 306.27).

Method of preparation Prepare as directed under Injections, with Fluconazole.

Description Fluconazole Injection occurs as a clear and colorless liquid.

Identification (1) Take a volume of Fluconazole Injection, equivalent to 0.1 g of Fluconazole, and evaporate to dryness on a water bath. To the residue add 10 mL of dilute hydrochloric acid, shake, and filter. Add 1 mL of Reinecke salt TS to the filtrate: a light red precipitate is produced.

(2) Determine the absorption spectrum of the sample solution obtained in the Assay as directed under Ultraviolet-visible Spectrophotometry <2.24>: it exhibits maxima between 259 nm and 263 nm, and between 264 nm and 268 nm.

pH Being specified separately when the drug is granted approval based on the Law.

Bacterial endotoxins <4.01> Less than 0.75 EU/mg.

Extractable volume <6.05> It meets the requirement.

Foreign insoluble matter <6.06> Perform the test according to Method 1: it meets the requirement.

Insoluble particulate matter <6.07> It meets the requirement.

Sterility <4.06> Perform the test according to the Membrane filtration method: it meets the requirement.

Assay Pipet a volume of Fluconazole Injection, equivalent to 10 mg of fluconazole ($C_{13}H_{12}F_2N_6O$), add water to make exactly 50 mL, and use this solution as the sample solution. Separately, weigh accurately about 50 mg of fluconazole for assay, previously dried at 105°C for 4 hours, dissolve in a solution of sodium chloride (9 in 1000) to make exactly 50 mL. Pipet 10 mL of this solution, add water to make exactly 50 mL, and use this solution as the standard solution. Determine the absorbances, A_T and A_S , of the sample solution and standard solution at 261 nm as directed under Ultraviolet-visible Spectrophotometry <2.24>.

$$\begin{aligned} &\text{Amount (mg) of fluconazole (C}_{13}\text{H}_{12}\text{F}_2\text{N}_6\text{O)} \\ &= M_S \times A_T/A_S \times 1/5 \end{aligned}$$

M_S : Amount (mg) of fluconazole for assay taken

Containers and storage Containers—Hermetic containers.

Flucytosine

フルシトシン

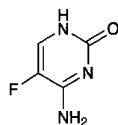

$C_4H_4FN_3O$: 129.09

5-Fluorocytosine

[2022-85-7]

Flucytosine, when dried, contains not less than 98.5% of flucytosine ($C_4H_4FN_3O$), and not less than 14.0% and not more than 15.5% of fluorine (F: 19.00).

Description Flucytosine occurs as a white crystalline powder. It is odorless.

It is sparingly soluble in water, slightly soluble in methanol, in ethanol (95), in acetic anhydride and in acetic acid (100), and practically insoluble in diethyl ether.

It dissolves in 0.1 mol/L hydrochloric acid TS.

The pH of a solution of 1.0 g of Flucytosine in 100 mL of water is between 5.5 and 7.5.

It is slightly hygroscopic.

Melting point: about 295°C (with decomposition).

Identification (1) Add 0.2 mL of bromine TS to 5 mL of a solution of Flucytosine (1 in 500): a yellow-brown color of bromine TS is immediately discharged. Further add 2 mL of barium hydroxide TS: a purple precipitate is formed.

(2) Proceed with 0.1 g of Flucytosine as directed under Oxygen Flask Combustion Method <1.06>, using a mixture of 0.5 mL of 0.01 mol/L sodium hydroxide TS and 20 mL of water as the absorbing liquid. The solution responds to Qualitative Tests <1.09> (2) for fluoride.

(3) Determine the absorption spectrum of a solution of Flucytosine in 0.1 mol/L hydrochloric acid TS (1 in 125,000) as directed under Ultraviolet-visible Spectrophotometry <2.24>, and compare the spectrum with the Reference Spectrum: both spectra exhibit similar intensities of absorption at the same wavelengths.

Purity (1) Clarity and color of solution—Dissolve 1.0 g of Flucytosine in 100 mL of water: the solution is clear and colorless.

(2) Chloride <1.03>—Dissolve 1.0 g of Flucytosine in 80 mL of water by heating on a water bath. After cooling, to 40 mL of this solution add 6 mL of dilute nitric acid and water to make 50 mL. Perform the test using this solution as the test solution. Prepare the control solution with 0.20 mL of 0.01 mol/L hydrochloric acid VS (not more than 0.014%).

(3) Fluoride—Dissolve 0.10 g of Flucytosine in 10.0 mL of diluted 0.01 mol/L sodium hydroxide TS (1 in 20). Transfer 5.0 mL of this solution to a 20-mL volumetric flask, add 10 mL of a mixture of alizarin complexone TS, acetic acid-potassium acetate buffer solution (pH 4.3) and cerrous nitrate TS (1:1:1), and add water to make 20 mL. Allow the mixture to stand for 1 hour, and use this solution as the sample solution. Separately, transfer 4.0 mL of Standard Fluorine Solution to a 20-mL volumetric flask, add 5.0 mL of diluted 0.01 mol/L sodium hydroxide TS (1 in 20), add 10 mL of a mixture of alizarin complexone TS, acetic acid-potassium acetate buffer solution (pH 4.3) and cerrous nitrate TS (1:1:1). Proceed in the same manner as directed in the preparation of the sample solution, and use this solution

as the standard solution. Transfer 5.0 mL of diluted 0.01 mol/L sodium hydroxide TS (1 in 20) to a 20-mL volumetric flask, proceed in the same manner as directed in the preparation of the standard solution, and use this solution as the blank solution. Determine the absorbances, A_T and A_S , of the sample solution and standard solution at 600 nm, using the blank solution as the control as directed under Ultraviolet-visible Spectrophotometry <2.24>: A_T is not larger than A_S (not more than 0.048%).

(4) Heavy metals <1.07>—Proceed with 1.0 g of Flucytosine according to Method 2, and perform the test. Prepare the control solution with 2.0 mL of Standard Lead Solution (not more than 20 ppm).

(5) Arsenic <1.11>—Prepare the test solution with 1.0 g of Flucytosine according to Method 2, and perform the test (not more than 2 ppm).

(6) Related substances—Dissolve 50 mg of Flucytosine in 5 mL of diluted methanol (1 in 2), and use this solution as the sample solution. Measure accurately 1 mL of the sample solution, add diluted methanol (1 in 2) to make exactly 25 mL. Measure accurately 1 mL of this solution, add diluted methanol (1 in 2) to make exactly 20 mL, and use this solution as the standard solution. Perform the test with these solutions as directed under Thin-layer Chromatography <2.03>. Spot 20 μ L each of the sample solution and standard solution on a plate of silica gel with fluorescent indicator for thin-layer chromatography. Develop the plate with a mixture of ethyl acetate, methanol and water (5:3:2) to a distance of about 12 cm, air-dry the plate, and observe the spots under ultraviolet light (main wavelength: 254 nm): the spots other than the principal spot obtained from the sample solution are not more intense than the spot from the standard solution.

Loss on drying <2.41> Not more than 1.0% (1 g, 105°C, 4 hours).

Residue on ignition <2.44> Not more than 0.1% (1 g).

Assay (1) Flucytosine—Weigh accurately about 0.2 g of Flucytosine, previously dried, dissolve in 40 mL of acetic acid (100), add 100 mL of acetic anhydride, and titrate <2.50> with 0.1 mol/L perchloric acid VS (potentiometric titration). Perform a blank determination in the same manner, and make any necessary correction.

Each mL of 0.1 mol/L perchloric acid VS
= 12.91 mg of $C_4H_4FN_3O$

(2) Fluorine—Weigh accurately about 10 mg of Flucytosine, previously dried, and proceed as directed in the determination of fluorine under Oxygen Flask Combustion Method <1.06>, using a mixture of 0.5 mL of 0.01 mol/L sodium hydroxide VS and 20 mL of water as the absorbing liquid.

Containers and storage Containers—Tight containers.

Storage—Light-resistant.

Fludiazepam

フルジアゼパム

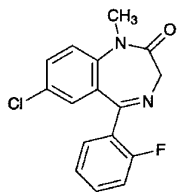

$C_{16}H_{12}ClFN_2O$: 302.73

7-Chloro-5-(2-fluorophenyl)-1-methyl-1,3-dihydro-2H-1,4-benzodiazepin-2-one

[3900-31-0]

Fludiazepam, when dried, contains not less than 99.0% of fludiazepam ($C_{16}H_{12}ClFN_2O$).

Description Fludiazepam occurs as white to light yellow, crystals or crystalline powder.

It is very soluble in chloroform, freely soluble in methanol, in ethanol (95), in acetic acid (100) and in diethyl ether, and practically insoluble in water.

Identification (1) Prepare the test solution with 0.01 g of Fludiazepam as directed under Oxygen Flask Combustion Method <1.06>, using a mixture of 0.5 mL of 0.01 mol/L sodium hydroxide TS and 20 mL of water as the absorbing liquid: the test solution responds to Qualitative Tests <1.09> (2) for fluoride.

(2) Determine the absorption spectrum of a solution of Fludiazepam in methanol (1 in 200,000) as directed under Ultraviolet-visible Spectrophotometry <2.24>, and compare the spectrum with the Reference Spectrum 1: both spectra exhibit similar intensities of absorption at the same wavelengths. Separately, determine the absorption spectrum of a solution of Fludiazepam in methanol (1 in 20,000) as directed under Ultraviolet-visible Spectrophotometry <2.24>, and compare the spectrum with the Reference Spectrum 2: both spectra exhibit similar intensities of absorption at the same wavelengths.

(3) Determine the infrared absorption spectrum of Fludiazepam, previously dried, as directed in the potassium bromide disk method under Infrared Spectrophotometry <2.25>, and compare the spectrum with the Reference Spectrum: both spectra exhibit similar intensities of absorption at the same wave numbers.

(4) Perform the test with Fludiazepam as directed under Flame Coloration Test <1.04> (2): a green color appears.

Melting point <2.60> 91 – 94°C

Purity (1) Chloride <1.03>—Dissolve 1.0 g of Fludiazepam in 50 mL of diethyl ether, add 50 mL of water, and shake. Separate the water layer, wash it with two 20-mL portions of diethyl ether, and filter the water layer. To 20 mL of the filtrate add 6 mL of dilute nitric acid and water to make 50 mL. Perform the test using this solution as the test solution. Prepare the control solution with 0.40 mL of 0.01 mol/L hydrochloric acid VS (not more than 0.036%).

(2) Heavy metals <1.07>—Proceed with 2.0 g of Fludiazepam according to Method 2, and perform the test. Prepare the control solution with 2.0 mL of Standard Lead Solution (not more than 10 ppm).

(3) Related substances—Dissolve 0.10 g of Fludiazepam in 20 mL of chloroform, and use this solution as the sample solution. Pipet 1 mL of the sample solution, and add chlo-

roform to make exactly 50 mL. Pipet 2 mL of this solution, add chloroform to make exactly 20 mL, and use this solution as the standard solution. Perform the test with these solutions as directed under Thin-layer Chromatography <2.03>. Spot 20 μ L each of the sample solution and standard solution on a plate of silica gel with fluorescent indicator for thin-layer chromatography. Develop the plate with a mixture of chloroform and ethyl acetate (10:7) to a distance of about 12 cm, and air-dry the plate. Examine under ultraviolet light (main wavelength: 254 nm): the spots other than the principal spot obtained from the sample solution are not more intense than the spot from the standard solution.

Loss on drying <2.41> Not more than 0.30% (1 g, in vacuum, 60°C, 3 hours).

Residue on ignition <2.44> Not more than 0.1% (1 g, platinum crucible).

Assay Weigh accurately about 0.5 g of Fludiazepam, previously dried, dissolve in 50 mL of acetic acid (100), and titrate <2.50> with 0.1 mol/L perchloric acid VS (potentiometric titration). Perform a blank determination in the same manner, and make any necessary correction.

Each mL of 0.1 mol/L perchloric acid VS
= 30.28 mg of $C_{16}H_{12}ClFN_2O$

Containers and storage Containers—Tight containers.

Fludiazepam Tablets

フルジアゼパム錠

Fludiazepam Tablets contain not less than 93.0% and not more than 107.0% of the labeled amount of fludiazepam ($C_{16}H_{12}ClFN_2O$: 302.73).

Method of preparation Prepare as directed under Tablets, with Fludiazepam.

Identification To a quantity of powdered Fludiazepam Tablets, equivalent to 2 mg of Fludiazepam, add 40 mL of methanol, shake for 20 minutes, and filter. Determine the absorption spectrum of the filtrate as directed under Ultraviolet-visible Spectrophotometry <2.24>: it exhibits a maximum between 315 nm and 319 nm. Therefore, to 5 mL of the filtrate add methanol to make 50 mL. Determine the absorption spectrum of this solution as directed under Ultraviolet-visible Spectrophotometry <2.24>: it exhibits a maximum between 229 nm and 233 nm.

Uniformity of dosage units <6.02> Perform the test according to the following method: it meets the requirement of the Content uniformity test.

To 1 tablet of Fludiazepam Tablets add 2V/25 mL of water, disintegrate the fine particles by sonicating, add 3V/25 mL of acetonitrile, and shake for 10 minutes. Add a mixture of acetonitrile and water (3:2) to make exactly V mL so that each mL contains about 5 μ g of fludiazepam ($C_{16}H_{12}ClFN_2O$), centrifuge, and use the supernatant liquid as the sample solution. Then, proceed as directed in the Assay.

Amount (mg) of fludiazepam ($C_{16}H_{12}ClFN_2O$)
= $M_S \times A_T/A_S \times V/5000$

M_S : Amount (mg) of fludiazepam for assay taken

Dissolution <6.10> When the test is performed at 50 revolutions per minute according to the Paddle method, using 900

mL of water as the dissolution medium, the dissolution rate in 15 minutes of Fludiazepam Tablets is not less than 80%.

Start the test with 1 tablet of Fludiazepam Tablets, withdraw not less than 20 mL of the medium at the specified minute after starting the test, and filter through a membrane filter with a pore size not exceeding 0.45 μm . Discard not less than 10 mL of the first filtrate, pipet V mL of the subsequent filtrate, add water to make exactly V' mL so that each mL contains about 0.28 μg of fludiazepam ($\text{C}_{16}\text{H}_{12}\text{ClFN}_2\text{O}$), and use this solution as the sample solution. Separately, weigh accurately about 28 mg of fludiazepam for assay, previously dried at 60°C for 3 hours under reduced pressure, and dissolve in methanol to make exactly 100 mL. Pipet 5 mL of this solution, and add water to make exactly 100 mL. Then, pipet 2 mL of this solution, and add water to make exactly 100 mL, and use this solution as the standard solution. Perform the test with exactly 50 μL each of the sample solution and standard solution as directed under Liquid Chromatography <2.01> according to the following conditions, and determine the peak areas, A_T and A_S , of fludiazepam in each solution.

$$\begin{aligned} & \text{Dissolution rate (\%)} \text{ with respect to the labeled amount} \\ & \text{of fludiazepam (C}_{16}\text{H}_{12}\text{ClFN}_2\text{O)} \\ & = M_S \times A_T/A_S \times V'/V \times 1/C \times 9/10 \end{aligned}$$

M_S : Amount (mg) of fludiazepam for assay taken

C : Labeled amount (mg) of fludiazepam ($\text{C}_{16}\text{H}_{12}\text{ClFN}_2\text{O}$) in 1 tablet

Operating conditions—

Detector, column temperature and flow rate: Proceed as directed in the operating conditions in the Assay.

Column: A stainless steel column 3.9 mm in inside diameter and 15 cm in length, packed with octadecylsilanized silica gel for liquid chromatography (5 μm in particle diameter).

Mobile phase: A mixture of water and acetonitrile (1:1).

System suitability—

System performance: When the procedure is run with 50 μL of the standard solution under the above operating conditions, the number of theoretical plates and the symmetry factor of the peak of fludiazepam are not less than 3000 and not more than 2.0, respectively.

System repeatability: When the test is repeated 6 times with 50 μL of the standard solution under the above operating conditions, the relative standard deviation of the peak area of fludiazepam is not more than 2.0%.

Assay Weigh accurately the mass of not less than 20 tablets of Fludiazepam Tablets, and powder. Weigh accurately a portion of the powder, equivalent to about 0.25 mg of fludiazepam ($\text{C}_{16}\text{H}_{12}\text{ClFN}_2\text{O}$), add 4 mL of water, disperse the fine particles by sonicating, add 6 mL of acetonitrile, and shake for 10 minutes. To this solution add a mixture of acetonitrile and water (3:2) to make exactly 50 mL, centrifuge, and use the supernatant liquid as the sample solution. Separately, weigh accurately about 25 mg of fludiazepam for assay, previously dried at 60°C for 3 hours under reduced pressure, dissolve in a mixture of acetonitrile and water (3:2) to make exactly 50 mL. Pipet 5 mL of this solution, add a mixture of acetonitrile and water (3:2) to make exactly 50 mL. Then, pipet 5 mL of this solution, add a mixture of acetonitrile and water (3:2) to make exactly 50 mL, and use this solution as the standard solution. Perform the test with exactly 20 μL each of the sample solution and standard solution as directed under Liquid Chromatography <2.01> according to the following conditions, and determine the peak areas, A_T and A_S , of fludiazepam in each solution.

$$\begin{aligned} & \text{Amount (mg) of fludiazepam (C}_{16}\text{H}_{12}\text{ClFN}_2\text{O)} \\ & = M_S \times A_T/A_S \times 1/100 \end{aligned}$$

M_S : Amount (mg) of fludiazepam for assay taken

Operating conditions—

Detector: An ultraviolet absorption photometer (wavelength: 232 nm).

Column: A stainless steel column 4.6 mm in inside diameter and 15 cm in length, packed with octadecylsilanized silica gel for liquid chromatography (5 μm in particle diameter).

Column temperature: A constant temperature of about 25°C.

Mobile phase: A mixture of methanol and water (3:2).

Flow rate: Adjust so that the retention time of fludiazepam is about 10 minutes.

System suitability—

System performance: When the procedure is run with 20 μL of the standard solution under the above operating conditions, the number of theoretical plates and the symmetry factor of the peak of fludiazepam are not less than 6000 and not more than 2.0, respectively.

System repeatability: When the test is repeated 6 times with 20 μL of the standard solution under the above operating conditions, the relative standard deviation of the peak area of fludiazepam is not more than 1.0%.

Containers and storage Containers—Tight containers.

Fludrocortisone Acetate

フルドコロチゾン酢酸エステル

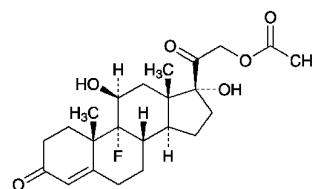

$\text{C}_{23}\text{H}_{31}\text{FO}_6$: 422.49

9-Fluoro-11 β ,17,21-trihydroxypregn-4-ene-3,20-dione
21-acetate

[514-36-3]

Fludrocortisone Acetate, when dried, contains not less than 97.5% and not more than 102.5% of fludrocortisone acetate ($\text{C}_{23}\text{H}_{31}\text{FO}_6$).

Description Fludrocortisone Acetate occurs as a white to pale yellow, crystals or crystalline powder.

It is soluble in acetone, sparingly soluble in ethanol (95), and practically insoluble in water.

Melting point: about 220°C (with decomposition).

Identification (1) Prepare the test solution by proceeding with 10 mg of Fludrocortisone Acetate according to the Oxygen Flask Combustion Method <1.06>, using a mixture of 0.5 mL of 0.01 mol/L sodium hydroxide VS and 20 mL of water as the absorbing liquid: the test solution responds to Qualitative Tests <1.09> for fluoride.

(2) Determine the absorption spectrum of a solution of Fludrocortisone Acetate in ethanol (95) (1 in 100,000) as directed under Ultraviolet-visible Spectrophotometry <2.24>, and compare the spectrum with the Reference Spectrum or the spectrum of a solution of Fludrocortisone Acetate RS prepared in the same manner as the sample solution: both spectra exhibit similar intensities of absorption at the same

wavelengths.

(3) Determine the infrared absorption spectrum of Fludrocortisone Acetate, previously dried, as directed in the potassium bromide disk method under Infrared Spectrophotometry <2.25>, and compare the spectrum with the Reference Spectrum or the spectrum of previously dried Fludrocortisone Acetate RS: both spectra exhibit similar intensities of absorption at the same wave numbers.

Optical rotation <2.49> $[\alpha]_D^{25}$: +131 – +138° (after drying, 0.1 g, acetone, 20 mL, 100 mm).

Purity (1) Heavy metals <1.07>—Proceed with 0.5 g of Fludrocortisone Acetate according to Method 2, and perform the test. Prepare the control solution with 1.5 mL of Standard Lead Solution (not more than 30 ppm).

(2) Related substances—Dissolve 20 mg of Fludrocortisone Acetate in 10 mL of the mobile phase, and use this solution as the sample solution. Pipet 1 mL of the sample solution, add the mobile phase to make exactly 50 mL, and use this solution as the standard solution. Perform the test with exactly 20 μ L each of the sample solution and standard solution as directed under Liquid Chromatography <2.01> according to the following conditions. Determine each peak area of both solutions by the automatic integration method: the area of each peak other than fludrocortisone acetate obtained from the sample solution is not larger than 1/4 times the peak area of fludrocortisone acetate from the standard solution, and the total area of the peaks other than fludrocortisone acetate from the sample solution is not larger than 1/2 times the peak area of fludrocortisone acetate from the standard solution.

Operating conditions—

Detector: An ultraviolet absorption photometer (wavelength: 254 nm).

Column: A stainless steel column 4.6 mm in inside diameter and 20 cm in length, packed with octadecylsilanized silica gel for liquid chromatography (5 μ m in particle diameter).

Column temperature: A constant temperature of about 25°C.

Mobile phase: A mixture of water and tetrahydrofuran (13:7).

Flow rate: Adjust so that the retention time of fludrocortisone acetate is about 10 minutes.

Time span of measurement: About 2 times as long as the retention time of fludrocortisone acetate, beginning after the solvent peak.

System suitability—

Test for required detectability: Pipet 5 mL of the standard solution, and add the mobile phase to make exactly 100 mL. Confirm that the peak area of fludrocortisone acetate obtained with 20 μ L of this solution is equivalent to 4.0 to 6.0% of that with 20 μ L of the standard solution.

System performance: Dissolve 2 mg each of Fludrocortisone Acetate and hydrocortisone acetate in 50 mL of the mobile phase. When the procedure is run with 20 μ L of this solution under the above operating conditions, hydrocortisone acetate and fludrocortisone acetate are eluted in this order with the resolution between these peaks being not less than 1.5.

System repeatability: When the test is repeated 6 times with 20 μ L of the standard solution under the above operating conditions, the relative standard deviation of the peak area of fludrocortisone acetate is not more than 2.0%.

Loss on drying <2.41> Not more than 1.0% (1 g, in vacuum, 100°C, 2 hours).

Residue on ignition <2.44> Not more than 0.1% (1 g, plati-

num crucible).

Assay Weigh accurately about 25 mg each of Fludrocortisone Acetate and Fludrocortisone Acetate RS, previously dried, and dissolve separately in ethanol (95) to make exactly 100 mL. Pipet 4 mL each of these solutions, add ethanol (95) to make exactly 100 mL, and use these solutions as the sample solution and the standard solution, respectively. Perform the test with the sample solution and standard solution as directed under Ultraviolet-visible Spectrophotometry <2.24>, and determine the absorbances, A_T and A_S , at 238 nm.

$$\begin{aligned} \text{Amount (mg) of fludrocortisone acetate (C}_{23}\text{H}_{31}\text{FO}_6) \\ = M_S \times A_T/A_S \end{aligned}$$

M_S : Amount (mg) of Fludrocortisone Acetate RS taken

Containers and storage Containers—Well-closed containers.

Storage—Light-resistant.

Flunitrazepam

フルニトラゼパム

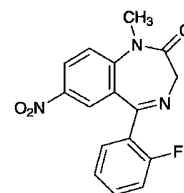

$C_{16}H_{12}FN_3O_3$: 313.28

5-(2-Fluorophenyl)-1-methyl-7-nitro-1,3-dihydro-2H-1,4-benzodiazepin-2-one
[1622-62-4]

Flunitrazepam, when dried, contains not less than 99.0% of flunitrazepam ($C_{16}H_{12}FN_3O_3$).

Description Flunitrazepam occurs as a white to pale yellow crystalline powder.

It is freely soluble in acetic acid (100), soluble in acetic anhydride and in acetone, slightly soluble in ethanol (99.5) and in diethyl ether, and practically insoluble in water.

Identification (1) Determine the absorption spectrum of a solution of Flunitrazepam in ethanol (99.5) (1 in 100,000) as directed under Ultraviolet-visible Spectrophotometry <2.24>, and compare the spectrum with the Reference Spectrum: both spectra exhibit similar intensities of absorption at the same wavelengths.

(2) Determine the infrared absorption spectrum of Flunitrazepam, previously dried, as directed in the potassium bromide disk method under Infrared Spectrophotometry <2.25>, and compare the spectrum with the Reference Spectrum: both spectra exhibit similar intensities of absorption at the same wave numbers.

Melting point <2.60> 168 – 172°C

Purity (1) Chloride <1.03>—To 1.0 g of Flunitrazepam add 50 mL of water, allow to stand for 1 hour with occasional stirring, and filter. To 20 mL of the filtrate add 6 mL of dilute nitric acid and water to make 50 mL, and perform the test with this solution. Prepare the control solution with 0.25 mL of 0.01 mol/L hydrochloric acid VS (not more than 0.022%).

(2) Heavy metals <1.07>—Proceed with 2.0 g of Flunitrazepam according to Method 4 using a platinum cru-

cible, and perform the test. Prepare the control solution with 2.0 mL of Standard Lead Solution (not more than 10 ppm).

(3) Related substances—Dissolve 50 mg of Flunitrazepam in 10 mL of acetone, and use this solution as the sample solution. Pipet 2 mL of the sample solution, and add acetone to make exactly 20 mL. Pipet 1 mL of this solution, add acetone to make exactly 25 mL, and use this solution as the standard solution. Perform the test with these solutions as directed under Thin-layer Chromatography <2.03>. Spot 10 μ L each of the sample solution and standard solution on a plate of silica gel with fluorescent indicator for thin-layer chromatography. Develop the plate with a mixture of 1,2-dichloroethane, diethyl ether and ammonia solution (28) (200:100:3) to a distance of about 12 cm, and air-dry the plate. Examine under ultraviolet light (main wavelength: 254 nm): number of the spots other than the principal spot obtained from the sample solution is not more than 2, and they are not more intense than the spot from the standard solution.

Loss on drying <2.41> Not more than 0.5% (1 g, 105°C, 4 hours).

Residue on ignition <2.44> Not more than 0.1% (1 g, platinum crucible).

Assay Weigh accurately about 0.5 g of Flunitrazepam, previously dried, dissolve in 20 mL of acetic acid (100), add 50 mL of acetic anhydride, and titrate <2.50> with 0.1 mol/L perchloric acid VS (potentiometric titration). Perform a blank determination in the same manner, and make any necessary correction.

Each mL of 0.1 mol/L perchloric acid VS
= 31.33 mg of C₁₆H₁₂FN₃O₃

Containers and storage Containers—Tight containers.
Storage—Light-resistant.

Fluocinolone Acetonide

フルオシノロンアセトニド

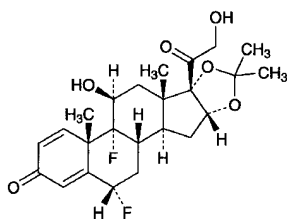

C₂₄H₃₀F₂O₆: 452.49
6 α ,9-Difluoro-11 β ,21-dihydroxy-16 α ,17-(1-methylethylidenedioxy)pregna-1,4-diene-3,20-dione [67-73-2]

Fluocinolone Acetonide, when dried, contains not less than 97.0% and not more than 102.0% of fluocinolone acetonide (C₂₄H₃₀F₂O₆).

Description Fluocinolone Acetonide occurs as white, crystals or crystalline powder.

It is freely soluble in acetic acid (100) and in acetone, soluble in ethanol (99.5), sparingly soluble in methanol, and practically insoluble in water.

Melting point: 266 – 274°C (with decomposition).

It shows crystal polymorphism.

Identification (1) To 2 mg of Fluocinolone Acetonide add

2 mL of sulfuric acid: a yellow color is produced.

(2) Dissolve 0.01 g of Fluocinolone Acetonide in 1 mL of methanol, add 1 mL of Fehling's TS, and heat: a red precipitate is produced.

(3) Proceed with 0.01 g of Fluocinolone Acetonide as directed under Oxygen Flask Combustion Method <1.06>, using a mixture of 0.5 mL of 0.01 mol/L sodium hydroxide TS and 20 mL of water as the absorbing liquid: the test solution responds to Qualitative Tests <1.09> for fluoride.

(4) Determine the infrared absorption spectrum of Fluocinolone Acetonide, previously dried, as directed in the potassium bromide disk method under Infrared Spectrophotometry <2.25>, and compare the spectrum with the Reference Spectrum or the spectrum of previously dried Fluocinolone Acetonide RS: both spectra exhibit similar intensities of absorption at the same wave numbers. If any difference appears between the spectra, dissolve Fluocinolone Acetonide and Fluocinolone Acetonide RS in acetone, respectively, then evaporate the acetone to dryness, and repeat the test on the residues.

Optical rotation <2.49> $[\alpha]_D^{20}$: +98 – +108° (after drying, 0.1 g, methanol, 10 mL, 100 mm).

Purity Related substances—Dissolve 15 mg of Fluocinolone Acetonide in 25 mL of the mobile phase, and use this solution as the sample solution. Pipet 2 mL of the sample solution, add the mobile phase to make exactly 100 mL, and use this solution as the standard solution. Perform the test with exactly 20 μ L each of the sample solution and standard solution as directed under Liquid Chromatography <2.01> according to the following conditions. Determine each peak area of each solution by the automatic integration method: the total area of the peaks other than fluocinolone acetonide obtained from the sample solution is not larger than the peak area of fluocinolone acetonide from the standard solution.

Operating conditions—

Detector: An ultraviolet absorption photometer (wavelength: 254 nm).

Column: A stainless steel column 4.6 mm in inside diameter and 15 cm in length, packed with silica gel for liquid chromatography (5 μ m in particle diameter).

Column temperature: A constant temperature of about 30°C.

Mobile phase: A mixture of water-saturated chloroform, methanol and acetic acid (100) (200:3:2).

Flow rate: Adjust so that the retention time of fluocinolone acetonide is about 12 minutes.

Time span of measurement: About 2 times as long as the retention time of fluocinolone acetonide, beginning after the solvent peak.

System suitability—

Test for required detectability: To exactly 5 mL of the standard solution add the mobile phase to make exactly 100 mL. Confirm that the peak area of fluocinolone acetonide obtained with 20 μ L of this solution is equivalent to 4 to 6% of that with 20 μ L of the standard solution.

System performance: Dissolve 15 mg each of Fluocinolone Acetonide and triamcinolone acetonide in 25 mL of the mobile phase. To 5 mL of this solution add the mobile phase to make 20 mL. When the procedure is run with 20 μ L of this solution under the above operating conditions, triamcinolone acetonide and fluocinolone acetonide are eluted in this order with the resolution between these peaks being not less than 1.9.

System repeatability: When the test is repeated 6 times with 20 μ L of the standard solution under the above operating conditions, the relative standard deviation of the peak

areas of fluocinolone acetonide is not more than 1.0%.

Loss on drying <2.41> Not more than 1.0% (0.2 g, in vacuum, 105°C, 3 hours).

Residue on ignition <2.44> Not more than 0.1% (0.2 g, platinum crucible).

Assay Weigh accurately about 20 mg each of Fluocinolone Acetonide and Fluocinolone Acetonide RS, previously dried, and dissolve in 40 mL each of methanol, add exactly 10 mL each of the internal standard solution, then add water to make 100 mL, and use these solutions as the sample solution and standard solution. Perform the test with 20 μ L each of the sample solution and standard solution as directed under Liquid Chromatography <2.01> according to the following conditions, and calculate the ratios, Q_T and Q_S , of the peak area of fluocinolone acetonide to that of the internal standard.

$$\begin{aligned} &\text{Amount (mg) of fluocinolone acetonide (C}_{24}\text{H}_{30}\text{F}_2\text{O}_6) \\ &= M_S \times Q_T / Q_S \end{aligned}$$

M_S : Amount (mg) of Fluocinolone Acetonide RS taken

Internal standard solution—A solution of ethyl parahydroxybenzoate (1 in 2500).

Operating conditions—

Detector: An ultraviolet absorption photometer (wavelength: 254 nm).

Column: A stainless steel column 4.6 mm in inside diameter and 25 cm in length, packed with octadecylsilanized silica gel for liquid chromatography (5 μ m in particle diameter).

Column temperature: A constant temperature of about 40°C.

Mobile phase: A mixture of water and acetonitrile (7:3).

Flow rate: Adjust so that the retention time of fluocinolone acetonide is about 20 minutes.

System suitability—

System performance: Dissolve 5 mg each of isopropyl parahydroxybenzoate and propyl parahydroxybenzoate in 50 mL of acetonitrile, and add water to make 100 mL. When the procedure is run with 20 μ L of this solution under the above operating conditions, isopropyl parahydroxybenzoate and propyl parahydroxybenzoate are eluted in this order with the resolution between these peaks being not less than 1.9.

System repeatability: When the test is repeated 6 times with 20 μ L of the standard solution under the above operating conditions, the relative standard deviation of the ratios of the peak area of fluocinolone acetonide to that of the internal standard is not more than 1.0%.

Containers and storage Containers—Tight containers.

Storage—Light-resistant.

Fluocinonide

フルオシノニド

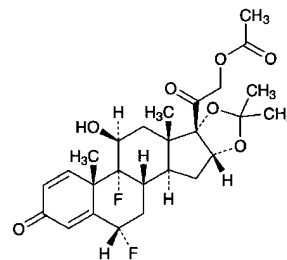

$C_{26}H_{32}F_2O_7$: 494.52

6 α ,9-Difluoro-11 β ,21-dihydroxy-16 α ,17-(1-methylethylidenedioxy)pregna-1,4-diene-3,20-dione 21-acetate
[356-12-7]

Fluocinonide, when dried, contains not less than 97.0% and not more than 103.0% of fluocinonide ($C_{26}H_{32}F_2O_7$).

Description Fluocinonide occurs as white, crystals or crystalline powder.

It is sparingly soluble in chloroform, slightly soluble in acetonitrile, in methanol, in ethanol (95) and in ethyl acetate, and practically insoluble in water.

It shows crystal polymorphism.

Identification (1) To 0.01 g of Fluocinonide add 4 mL of water and 1 mL of Fehling's TS, and heat: a red precipitate is formed.

(2) Prepare the test solution with 0.01 g of Fluocinonide as directed under Oxygen Flask Combustion Method <1.06>, using a mixture of 0.5 mL of 0.01 mol/L sodium hydroxide TS and 20 mL of water as an absorbing liquid: the test solution responds to Qualitative Tests <1.09> for fluoride.

(3) Determine the absorption spectrum of a solution of Fluocinonide in methanol (1 in 100,000) as directed under Ultraviolet-visible Spectrophotometry <2.24>, and compare the spectrum with the Reference Spectrum or the spectrum of a solution of Fluocinonide RS prepared in the same manner as the sample solution: both spectra exhibit similar intensities of absorption at the same wavelengths.

(4) Determine the infrared absorption spectra of Fluocinonide and Fluocinonide RS, previously dried, as directed in the potassium bromide disk method under Infrared Spectrophotometry <2.25>, and compare both spectra: both spectra exhibit similar intensities of absorption at the same wave numbers. If any difference appears in the absorption spectra, dissolve the sample and the RS in ethyl acetate, respectively, evaporate the ethyl acetate, and perform the test with the residue in the same manner.

Optical rotation <2.49> $[\alpha]_D^{20}$: +81 – +89° (after drying, 0.2 g, chloroform, 20 mL, 100 mm).

Purity Related substances—Dissolve 10 mg of Fluocinonide in 2 mL of chloroform, and use this solution as the sample solution. Pipet 1 mL of the sample solution, add chloroform to make exactly 100 mL, and use this solution as the standard solution. Perform the test with these solutions as directed under Thin-layer Chromatography <2.03>. Spot 10 μ L each of the sample solution and standard solution on a plate of silica gel for thin-layer chromatography. Develop the plate with a mixture of chloroform and methanol (97:3)

to a distance of about 12 cm, and air-dry the plate. Spray evenly alkaline blue tetrazolium TS on the plate: the spots other than the principal spot obtained from the sample solution are not more intense than the spot from the standard solution.

Loss on drying <2.41> Not more than 1.0% (0.5 g, 105°C, 3 hours).

Residue on ignition <2.44> Not more than 0.1% (0.5 g, platinum crucible).

Assay Weigh accurately about 20 mg each of Fluocinonide and Fluocinonide RS, previously dried, dissolve each in 50 mL of acetonitrile, to each add exactly 8 mL of the internal standard solution and water to make 100 mL, and use these solutions as the sample solution and the standard solution, respectively. Perform the test with 20 μ L each of the sample solution and standard solution as directed under Liquid Chromatography <2.01> according to the following conditions, and calculate the ratios, Q_T and Q_S , of the peak area of fluocinonide to that of the internal standard, respectively.

$$\begin{aligned} &\text{Amount (mg) of fluocinonide (C}_{26}\text{H}_{32}\text{F}_2\text{O}_7) \\ &= M_S \times Q_T/Q_S \end{aligned}$$

M_S : Amount (mg) of Fluocinonide RS taken

Internal standard solution—A solution of propyl benzoate in acetonitrile (1 in 100).

Operating conditions—

Detector: An ultraviolet absorption photometer (wavelength: 254 nm).

Column: A stainless steel column 4.6 mm in inside diameter and 25 cm in length, packed with octadecylsilanized silica gel for liquid chromatography (5 μ m in particle diameter).

Column temperature: A constant temperature of about 40°C.

Mobile phase: A mixture of water and acetonitrile (1:1).

Flow rate: Adjust so that the retention time of fluocinonide is about 8 minutes.

System suitability—

System performance: When the procedure is run with 20 μ L of the standard solution under the above operating conditions, fluocinonide and the internal standard are eluted in this order with the resolution between these peaks being not less than 6.

System repeatability: When the test is repeated 6 times with 20 μ L of the standard solution under the above operating conditions, the relative standard deviation of the ratios of the peak area of fluocinonide to that of the internal standard is not more than 1.0%.

Containers and storage Containers—Well-closed containers.

Fluorescein Sodium

フルオレセインナトリウム

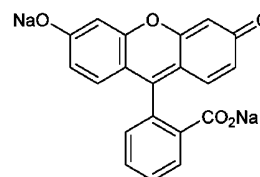

$\text{C}_{20}\text{H}_{10}\text{Na}_2\text{O}_5$; 376.27

Disodium 2-(6-oxido-3-oxo-3H-xanthen-9-yl)benzoate
[518-47-8]

Fluorescein Sodium contains not less than 98.5% of fluorescein sodium ($\text{C}_{20}\text{H}_{10}\text{Na}_2\text{O}_5$), calculated on the dried basis.

Description Fluorescein Sodium occurs as an orange powder. It is odorless, and tasteless.

It is freely soluble in water, in methanol and in ethanol (95), and practically insoluble in diethyl ether.

It is hygroscopic.

Identification (1) To a solution of Fluorescein Sodium (1 in 100) having a strong green fluorescence, add a large quantity of water: the fluorescence remains. Acidify the solution with hydrochloric acid: the fluorescence disappears. Then render the solution alkaline with sodium hydroxide TS: the fluorescence reappears.

(2) Place 1 drop of a solution of Fluorescein Sodium (1 in 2000) on a piece of filter paper: a yellow spot develops. Expose the spot, while moist, to the vapor of bromine for 1 minute and then to ammonia vapor: the yellow color of the spot changes to red.

(3) Char 0.5 g of Fluorescein Sodium by ignition, cool, mix the residue with 20 mL of water, and filter: the filtrate responds to Qualitative Tests <1.09> for sodium salt.

Purity (1) Clarity and color of solution—Dissolve 1 g of Fluorescein Sodium in 10 mL of water: the solution is clear, and shows a red color.

(2) Chloride <1.03>—Dissolve 0.15 g of Fluorescein Sodium in 20 mL of water, add 6 mL of dilute nitric acid and water to make 30 mL, and filter. To 20 mL of the filtrate add 2 mL of dilute nitric acid and water to make 50 mL. Perform the test using this solution as the test solution. Prepare the control solution with 1.0 mL of 0.01 mol/L hydrochloric acid VS (not more than 0.355%).

(3) Sulfate <1.14>—Dissolve 0.20 g of Fluorescein Sodium in 30 mL of water, add 2.5 mL of dilute hydrochloric acid and water to make 40 mL, and filter. To 20 mL of the filtrate add water to make 50 mL. Perform the test using this solution as the test solution. Prepare the control solution with 1.0 mL of 0.005 mol/L sulfuric acid VS (not more than 0.480%).

(4) Zinc—Dissolve 0.10 g of Fluorescein Sodium in 10 mL of water, add 2 mL of hydrochloric acid, and filter. To the filtrate add 0.1 mL of potassium hexacyanoferrate (II) TS: no turbidity is produced immediately.

(5) Related substances—Dissolve 0.20 g of Fluorescein Sodium in exactly 10 mL of methanol, and use this solution as the sample solution. Perform the test with this solution as directed under Thin-layer Chromatography <2.03>. Spot 5 μ L of the sample solution on a plate of silica gel for thin-layer chromatography. Develop the plate with a mixture of chloroform, methanol and ammonia solution (28) (30:15:1)

to a distance of about 10 cm, and air-dry the plate: any colored spot other than the principal spot does not appear.

Loss on drying <2.41> Not more than 10.0% (1 g, 105°C, constant mass).

Assay Transfer about 0.5 g of Fluorescein Sodium, accurately weighed, to a separator. Dissolve in 20 mL of water, add 5 mL of dilute hydrochloric acid, and extract with four 20-mL portions of a mixture of 2-methyl-1-propanol and chloroform (1:1). Wash each extract successively with the same 10 mL of water. Evaporate the combined extracts on a water bath with the aid of a current of air. Dissolve the residue in 10 mL of ethanol (99.5), evaporate the solution on a water bath to dryness, dry the residue at 105°C for 1 hour, and weigh as fluorescein (C₂₀H₁₂O₅: 332.31).

$$\begin{aligned} \text{Amount (mg) of fluorescein sodium (C}_{20}\text{H}_{10}\text{Na}_2\text{O}_5) \\ = \text{amount (mg) of fluorescein (C}_{20}\text{H}_{12}\text{O}_5) \times 1.132 \end{aligned}$$

Containers and storage Containers—Tight containers.

Fluorometholone

フルオロメトロン

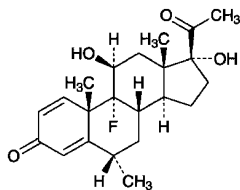

C₂₂H₂₉FO₄: 376.46

9-Fluoro-11β,17-dihydroxy-6α-methylpregna-1,4-diene-3,20-dione
[426-13-1]

Fluorometholone, when dried, contains not less than 97.0% and not more than 103.0% of fluorometholone (C₂₂H₂₉FO₄).

Description Fluorometholone occurs as a white to light yellow-white crystalline powder. It is odorless.

It is freely soluble in pyridine, slightly soluble in methanol, in ethanol (99.5) and in tetrahydrofuran, and practically insoluble in water and in diethyl ether.

Identification (1) Proceed with 7 mg of Fluorometholone as directed under Oxygen Flask Combustion Method <1.06>, using a mixture of 0.5 mL of 0.01 mol/L sodium hydroxide TS and 20 mL of water as an absorbing liquid: the liquid responds to Qualitative Tests <1.09> (2) for fluoride.

(2) Determine the absorption spectrum of a solution of Fluorometholone in methanol (1 in 100,000) as directed under Ultraviolet-visible Spectrophotometry <2.24>, and compare the spectrum with the Reference Spectrum or the spectrum of a solution of Fluorometholone RS prepared in the same manner as the sample solution: both spectra exhibit similar intensities of absorption at the same wavelengths.

(3) Determine the infrared absorption spectrum of Fluorometholone, previously dried, as directed in the potassium bromide disk method under Infrared Spectrophotometry <2.25>, and compare the spectrum with the Reference Spectrum or the spectrum of previously dried Fluorometholone RS: both spectra exhibit similar intensities of absorption at the same wave numbers.

Optical rotation <2.49> [α]_D²⁰: +52 – +60° (after drying,

0.1 g, pyridine, 10 mL, 100 mm).

Purity (1) Heavy metals <1.07>—Proceed with 1.0 g of Fluorometholone according to Method 3, and perform the test. Prepare the control solution with 2.0 mL of Standard Lead Solution (not more than 20 ppm).

(2) Related substances—Dissolve 20 mg of Fluorometholone in 10 mL of tetrahydrofuran, and use this solution as the sample solution. Pipet 1 mL of the sample solution, add tetrahydrofuran to make exactly 100 mL, and use this solution as the standard solution. Perform the test with these solutions as directed under Thin-layer chromatography <2.03>. Spot 25 μL each of the sample solution and standard solution on a plate of silica gel with fluorescent indicator for thin-layer chromatography. Develop the plate with a mixture of dichloromethane, acetone and methanol (45:5:1) to a distance of about 12 cm, and air-dry the plate. Examine under ultraviolet light (main wavelength: 254 nm): the spots other than the principal spot obtained from the sample solution are not more intense than the spot from the standard solution.

Loss on drying <2.41> Not more than 1.0% (0.2 g, in vacuum, phosphorus (V) oxide, 60°C, 3 hours).

Residue on ignition <2.44> Not more than 0.2% (0.2 g, platinum crucible).

Assay Weigh accurately about 0.1 g each of Fluorometholone and Fluorometholone RS, previously dried, and dissolve each in methanol to make exactly 100 mL. Pipet 5 mL each of these solutions, and add diluted methanol (7 in 10) to make exactly 50 mL. Pipet 10 mL each of these solutions, add exactly 10 mL of the internal standard solution and diluted methanol (7 in 10) to make 100 mL, and use these solutions as the sample solution and the standard solution, respectively. Perform the test with 20 μL each of the sample solution and standard solution as directed under Liquid Chromatography <2.01> according to the following conditions and calculate the ratios, Q_T and Q_S, of the peak area of fluorometholone to that of the internal standard.

$$\begin{aligned} \text{Amount (mg) of fluorometholone (C}_{22}\text{H}_{29}\text{FO}_4) \\ = M_S \times Q_T/Q_S \end{aligned}$$

M_S: Amount (mg) of Fluorometholone RS taken

Internal standard solution—A solution of butyl parahydroxybenzoate in methanol (1 in 10,000).

Operating conditions—

Detector: An ultraviolet absorption photometer (wavelength: 254 nm).

Column: A stainless steel column about 4 mm in inside diameter and 25 to 30 cm in length, packed with octadecylsilanized silica gel for liquid chromatography (5 μm in particle diameter).

Column temperature: A constant temperature of about 35°C.

Mobile phase: Diluted methanol (7 in 10).

Flow rate: Adjust so that the retention time of fluorometholone is about 8 minutes.

Selection of column: Proceed with 20 μL of the standard solution under the above operating conditions, and calculate the resolution. Use a column giving elution of fluorometholone and the internal standard in this order with the resolution between these peaks being not less than 4.

Containers and storage Containers—Well-closed containers.

Storage—Light-resistant.

Fluorouracil

フルオロウラシル

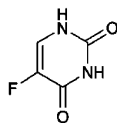

$C_4H_3FN_2O_2$: 130.08

5-Fluorouracil

[51-21-8]

Fluorouracil, when dried, contains not less than 98.5% of fluorouracil ($C_4H_3FN_2O_2$), and not less than 13.1% and not more than 16.1% of fluorine (F: 19.00).

Description Fluorouracil occurs as white, crystals or crystalline powder. It is odorless.

It is freely soluble in *N,N*-dimethylformamide, sparingly soluble in water, slightly soluble in ethanol (95), and practically insoluble in diethyl ether.

Melting point: about 282°C (with decomposition).

Identification (1) Add 0.2 mL of bromine TS to 5 mL of a solution of Fluorouracil (1 in 500): the color of bromine TS is discharged. Further add 2 mL of barium hydroxide TS: a purple precipitate is formed.

(2) Proceed with 0.01 g of Fluorouracil as directed under Oxygen Flask Combustion Method <1.06>, using a mixture of 0.5 mL of 0.01 mol/L sodium hydroxide TS and 20 mL of water as the absorbing liquid: the test solution responds to Qualitative Tests <1.09> for fluoride.

(3) Determine the absorption spectrum of a solution of Fluorouracil in 0.1 mol/L hydrochloric acid TS (1 in 100,000) as directed under Ultraviolet-visible Spectrophotometry <2.24>, and compare the spectrum with the Reference Spectrum: both spectra exhibit similar intensities of absorption at the same wavelengths.

Purity (1) Clarity and color of solution—Add 20 mL of water to 0.20 g of Fluorouracil, and dissolve by warming: the solution is clear and colorless.

(2) Fluoride—Dissolve 0.10 g of Fluorouracil in 10.0 mL of diluted 0.01 mol/L sodium hydroxide TS (1 in 20). Transfer 5.0 mL of this solution to a 20-mL volumetric flask, add 10 mL of a mixture of alizarin complexone TS, acetic acid-potassium acetate buffer solution (pH 4.3) and cerium (III) nitrate TS (1:1:1), and add water to make 20 mL. Allow to stand for 1 hour, and use this solution as the sample solution. Separately, transfer 1.0 mL of Standard Fluorine Solution to a 20-mL volumetric flask, add 5.0 mL of diluted 0.01 mol/L sodium hydroxide TS (1 in 20), and add 10 mL of a mixture of alizarin complexone TS, acetic acid-potassium acetate buffer solution (pH 4.3) and cerium (III) nitrate TS (1:1:1). Proceed in the same manner as directed for the preparation of the sample solution, and use this solution as the standard solution. Perform the test as directed under Ultraviolet-visible Spectrophotometry <2.24>, using a solution, prepared with 5.0 mL of diluted 0.01 mol/L sodium hydroxide TS (1 in 20) in the same manner, as the blank: the absorbance of the sample solution at 600 nm is not larger than that of the standard solution (not more than 0.012%).

(3) Heavy metals <1.07>—Proceed with 1.0 g of Fluorouracil according to Method 2, and perform the test. Prepare the control solution with 2.0 mL of Standard Lead Solution (not more than 20 ppm).

(4) Arsenic <1.11>—To 1.0 g of Fluorouracil in a crucible add 10 mL of a solution of magnesium nitrate hexahydrate in ethanol (95) (1 in 10), ignite the ethanol to burn, and incinerate by strong heating at 750°C to 850°C. If a carbonized substance remains in this method, moisten with a small amount of nitric acid, and incinerate by strong heating. Cool, add 10 mL of dilute hydrochloric acid to the residue, dissolve it by warming on a water bath, use this solution as the test solution, and perform the test (not more than 2 ppm).

(5) Related substances—Dissolve 0.10 g of Fluorouracil in 10 mL of water, and use this solution as the sample solution. Measure exactly 1 mL of the sample solution, add water to make exactly 200 mL, and use this solution as the standard solution. Perform the test with these solutions as directed under Thin-layer Chromatography <2.03>. Spot 10 μL each of the sample solution and standard solution on a plate of silica gel with fluorescent indicator for thin-layer chromatography. Develop the plate with a mixture of ethyl acetate, acetone and water (7:4:1) to a distance of about 12 cm, air-dry the plate, and examine under ultraviolet light (main wavelength: 254 nm): the spots other than the principal spot obtained from the sample solution are not more intense than the spot from the standard solution.

Loss on drying <2.41> Not more than 0.5% (1 g, in vacuum, 80°C, 4 hours).

Residue on ignition <2.44> Not more than 0.1% (1 g).

Assay (1) Fluorouracil—Weigh accurately about 0.2 g of Fluorouracil, previously dried, dissolve in 20 mL of *N,N*-dimethylformamide, and titrate <2.50> with 0.1 mol/L tetramethylammonium hydroxide VS until the color of the solution changes from yellow through blue-green to blue (indicator: 3 drops of thymol blue-dimethylformamide TS). Perform a blank determination in the same manner, and make any necessary correction.

Each mL of 0.1 mol/L tetramethylammonium hydroxide VS
= 13.01 mg of $C_4H_3FN_2O_2$

(2) Fluorine—Weigh accurately about 4 mg of Fluorouracil, previously dried, and proceed as directed in the determination of fluorine under Oxygen Flask Combustion Method <1.06>, using a mixture of 0.5 mL of 0.01 mol/L sodium hydroxide TS and 20 mL of water as the absorbing liquid.

Containers and storage Containers—Tight containers.

Fluphenazine Enanthate

フルフェナジンエナンテート酸エステル

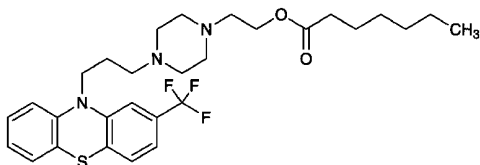

$C_{29}H_{38}F_3N_3O_2S$: 549.69

2-(4-{3-[2-(Trifluoromethyl)-10H-phenothiazin-10-yl]propyl}piperazin-1-yl)ethyl heptanoate
[2746-81-8]

Fluphenazine Enanthate, when dried, contains not less than 98.5% of fluphenazine enanthate ($C_{29}H_{38}F_3N_3O_2S$).

Description Fluphenazine Enanthate is a light yellow to yellowish orange viscous liquid. It is generally clear, and can be opaque by producing crystals.

It is freely soluble in methanol and in diethyl ether, soluble in ethanol (95) and in acetic acid (100), and practically insoluble in water.

Identification (1) Prepare the test solution with 0.01 g of Fluphenazine Enanthate as directed under Oxygen Flask Combustion Method <1.06>, using a mixture of 0.5 mL of 0.01 mol/L sodium hydroxide TS and 20 mL of water as the absorbing liquid: the test solution responds to Qualitative Tests <1.09> for fluoride.

(2) Dissolve 2 mg of Fluphenazine Enanthate in 200 mL of a solution of hydrochloric acid in methanol (17 in 2000). Determine the absorption spectrum of the solution as directed under Ultraviolet-visible Spectrophotometry <2.24>, and compare the spectrum with the Reference Spectrum: both spectra exhibit similar intensities of absorption at the same wavelengths.

(3) Determine the infrared absorption spectrum of Fluphenazine Enanthate as directed in the liquid film method under Infrared Spectrophotometry <2.25>, and compare the spectrum with the Reference Spectrum: both spectra exhibit similar intensities of absorption at the same wave numbers.

Purity (1) Heavy metals <1.07>—Proceed with 1.0 g of Fluphenazine Enanthate according to Method 2, and perform the test. Prepare the control solution with 3.0 mL of Standard Lead Solution (not more than 30 ppm).

(2) Related substances—Dissolve 0.25 g of Fluphenazine Enanthate in 10 mL of methanol, and use this solution as the sample solution. Pipet 1 mL of the sample solution, add methanol to make exactly 100 mL, and use this solution as the standard solution. Perform the test with these solutions as directed under Thin-layer Chromatography <2.03>. Spot 20 μ L each of the sample solution and standard solution on a plate of silica gel with fluorescent indicator for thin-layer chromatography. Develop the plate with a mixture of acetone, hexane and ammonia solution (28) (16:6:1) to a distance of about 15 cm, and air-dry the plate. Examine under ultraviolet light (main wavelength: 254 nm): the spots other than the principal spot from the sample solution are not more intense than the spot from the standard solution. Then spray evenly diluted sulfuric acid (1 in 2) on the plate: the spots other than the principal spot obtained from the sample solution are not more intense than the spot from the stand-

ard solution.

Loss on drying <2.41> Not more than 1.0% (1 g, in vacuum, 60°C, 3 hours).

Residue on ignition <2.44> Not more than 0.2% (1 g).

Assay Weigh accurately about 0.5 g of Fluphenazine Enanthate, previously dried, dissolve in 50 mL of acetic acid (100), and titrate <2.50> with 0.1 mol/L perchloric acid VS (indicator: 2 drops of crystal violet TS). Perform a blank determination in the same manner, and make any necessary correction.

Each mL of 0.1 mol/L perchloric acid VS
= 27.49 mg of $C_{29}H_{38}F_3N_3O_2S$

Containers and storage Containers—Tight containers.
Storage—Light-resistant.

Flurazepam Hydrochloride

フルラゼパム塩酸塩

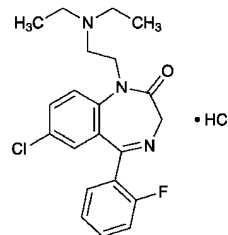

$C_{21}H_{23}ClFN_3O \cdot HCl$: 424.34

7-Chloro-1-[2-(diethylamino)ethyl]-5-(2-fluorophenyl)-1,3-dihydro-2H-1,4-benzodiazepin-2-one monohydrochloride
[36105-20-1]

Flurazepam Hydrochloride, when dried, contains not less than 99.0% of flurazepam hydrochloride ($C_{21}H_{23}ClFN_3O \cdot HCl$).

Description Flurazepam Hydrochloride occurs as white to yellowish white, crystals or crystalline powder.

It is freely soluble in water, in ethanol (95), in ethanol (99.5) and in acetic acid (100).

Melting point: about 197°C (with decomposition).

Identification (1) Determine the absorption spectrum of a solution of Flurazepam Hydrochloride in sulfuric acid-ethanol TS (1 in 100,000) as directed under Ultraviolet-visible Spectrophotometry <2.24>, and compare the spectrum with the Reference Spectrum: both spectra exhibit similar intensities of absorption at the same wavelengths.

(2) Determine the infrared absorption spectrum of Flurazepam Hydrochloride, previously dried, as directed in the potassium chloride disk method under Infrared Spectrophotometry <2.25>, and compare the spectrum with the Reference Spectrum: both spectra exhibit similar intensities of absorption at the same wave numbers.

(3) A solution of Flurazepam Hydrochloride (1 in 20) responds to Qualitative Tests <1.09> for chloride.

pH <2.54> Dissolve 1.0 g of Flurazepam Hydrochloride in 20 mL of water: the pH of this solution is between 5.0 and 6.0.

Purity (1) Clarity and color of solution—Dissolve 1.0 g of Flurazepam Hydrochloride in 10 mL of water: the solution is clear and colorless to pale yellow.

(2) Sulfate <1.14>—Perform the test with 1.5 g of Flurazepam Hydrochloride. Prepare the control solution with 0.35 mL of 0.005 mol/L sulfuric acid VS (not more than 0.011%).

(3) Heavy metals <1.07>—Proceed with 1.0 g of Flurazepam Hydrochloride in a platinum crucible according to Method 2, and perform the test. Prepare the control solution with 2.0 mL of Standard Lead Solution (not more than 20 ppm).

(4) Related substances—Dissolve 0.05 g of Flurazepam Hydrochloride in 5 mL of ethanol (95), and use this solution as the sample solution. Pipet 1 mL of the sample solution, add ethanol (95) to make exactly 50 mL. Pipet 1 mL of this solution, add ethanol (95) to make exactly 10 mL, and use this solution as the standard solution. Perform the test with these solutions as directed under Thin-layer Chromatography <2.03>. Spot 20 μ L each of the sample solution and standard solution on a plate of silica gel with fluorescent indicator for thin-layer chromatography. Place the plate in a chamber filled with ammonia vapor, allow to stand for about 15 minutes, and immediately develop the plate with a mixture of diethyl ether and diethylamine (39:1) to a distance of about 12 cm, and air-dry the plate. Examine under ultraviolet light (main wavelength: 254 nm): not more than 3 spots other than the principal spot and the spot on the starting point obtained from the sample solution appear, and are not more intense than the spot from the standard solution.

Loss on drying <2.41> Not more than 0.5% (1 g, 105°C, 4 hours).

Residue on ignition <2.44> Not more than 0.1% (1 g).

Assay Weigh accurately about 0.3 g of Flurazepam Hydrochloride, previously dried, dissolve in 10 mL of acetic acid (100), add 40 mL of acetic anhydride, and titrate <2.50> with 0.1 mol/L perchloric acid VS (potentiometric titration). Perform a blank determination in the same manner, and make any necessary correction.

Each mL of 0.1 mol/L perchloric acid VS
= 21.22 mg of C₂₁H₂₃ClFN₃O.HCl

Containers and storage Containers—Tight containers.

Flurbiprofen

フルルビプロフェン

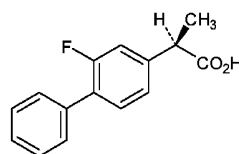

and enantiomer

C₁₅H₁₃FO₂: 244.26

(2*RS*)-2-(2-Fluorobiphenyl-4-yl)propanoic acid
[5104-49-4]

Flurbiprofen, when dried, contains not less than 98.0% of flurbiprofen (C₁₅H₁₃FO₂).

Description Flurbiprofen occurs as a white crystalline powder. It has a slightly irritating odor.

It is freely soluble in methanol, in ethanol (95), in acetone and in diethyl ether, soluble in acetonitrile, and practically insoluble in water.

A solution of Flurbiprofen in ethanol (95) (1 in 50) shows no optical rotation.

Identification (1) Determine the absorption spectrum of a solution of Flurbiprofen in methanol (1 in 200,000) as directed under Ultraviolet-visible Spectrophotometry <2.24>, and compare the spectrum with the Reference Spectrum: both spectra exhibit similar intensities of absorption at the same wavelengths.

(2) Determine the infrared absorption spectrum of Flurbiprofen, previously dried, as directed in the potassium bromide disk method under Infrared Spectrophotometry <2.25>, and compare the spectrum with the Reference Spectrum: both spectra exhibit similar intensities of absorption at the same wave numbers.

Melting point <2.60> 114 – 117°C

Purity (1) Chloride <1.03>—Dissolve 0.6 g of Flurbiprofen in 40 mL of acetone, and add 6 mL of dilute nitric acid and water to make 50 mL. Perform the test using this solution as the test solution. Prepare the control solution as follows: to 0.25 mL of 0.01 mol/L hydrochloric acid VS add 40 mL of acetone, 6 mL of dilute nitric acid and water to make 50 mL (not more than 0.015%).

(2) Heavy metals <1.07>—Dissolve 2.0 g of Flurbiprofen in 30 mL of acetone, and add 2 mL of dilute acetic acid and water to make 50 mL. Perform the test using this solution as the test solution. Prepare the control solution as follows: to 2.0 mL of Standard Lead Solution add 30 mL of acetone, 2 mL of dilute acetic acid and water to make 50 mL (not more than 10 ppm).

(3) Related substances—Dissolve 20 mg of Flurbiprofen in 10 mL of a mixture of water and acetonitrile (11:9), and use this solution as the sample solution. Pipet 1 mL of the sample solution, and add a mixture of water and acetonitrile (11:9) to make exactly 200 mL, and use this solution as the standard solution. Perform the test with exactly 20 μ L each of the sample solution and standard solution as directed under Liquid Chromatography <2.01> according to the following conditions. Determine each peak area of both solutions by the automatic integration method: the area of the peak other than flurbiprofen obtained from the sample solution is not larger than the peak area of flurbiprofen from the standard solution, and the total area of these peaks is not larger than 2 times the peak area of flurbiprofen from the standard solution.

Operating conditions—

Detector: An ultraviolet absorption photometer (wavelength: 254 nm).

Column: A stainless steel column 4.6 mm in inside diameter and 15 cm in length, packed with octadecylsilanized silica gel for liquid chromatography (5 μ m in particle diameter).

Column temperature: A constant temperature of about 30°C.

Mobile phase: A mixture of water, acetonitrile and acetic acid (100) (12:7:1).

Flow rate: Adjust so that the retention time of flurbiprofen is about 20 minutes.

Time span of measurement: About twice as long as the retention time of flurbiprofen, beginning after the solvent peak.

System suitability—

Test for required detectability: To exactly 5 mL of the standard solution add a mixture of water and acetonitrile (11:9) to make exactly 25 mL. Confirm that the peak area of flurbiprofen obtained with 20 μ L of this solution is equivalent to 16 to 24% of that with 20 μ L of the standard solution.

System performance: Dissolve 0.04 g of flurbiprofen and 0.02 g of butyl parahydroxybenzoate in 100 mL of a mixture

of water and acetonitrile (11:9). To 5 mL of this solution add a mixture of water and acetonitrile (11:9) to make 50 mL. When the procedure is run with 20 μ L of this solution under the above operating conditions, butyl parahydroxybenzoate and flurbiprofen are eluted in this order with the resolution between these peaks being not less than 12.

System repeatability: When the test is repeated 6 times with 20 μ L of the standard solution under the above operating conditions, the relative standard deviation of the peak area of flurbiprofen is not more than 2.0%.

Loss on drying <2.41> Not more than 0.10% (1 g, in vacuum at a pressure not exceeding 0.67 kPa, silica gel, 4 hours).

Residue on ignition <2.44> Not more than 0.1% (1 g, platinum crucible).

Assay Weigh accurately about 0.6 g of Flurbiprofen, previously dried, dissolve in 50 mL of ethanol (95), and titrate <2.50> with 0.1 mol/L sodium hydroxide VS (indicator: 3 drops of phenolphthalein TS). Perform a blank determination in the same manner, and make any necessary correction.

Each mL of 0.1 mol/L sodium hydroxide VS
= 24.43 mg of C₁₅H₁₃FO₂

Containers and storage Containers—Well-closed containers.

Flutamide

フルタミド

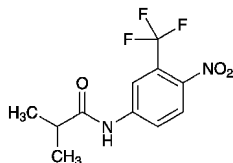

C₁₁H₁₁F₃N₂O₃; 276.21
2-Methyl-N-[4-nitro-3-(trifluoromethyl)phenyl]propanamide
[13311-84-7]

Flutamide, when dried, contains not less than 98.5% and not more than 101.5% of flutamide (C₁₁H₁₁F₃N₂O₃).

Description Flutamide occurs as a light yellow crystalline powder.

It is freely soluble in methanol and in ethanol (95), and practically insoluble in water.

Identification (1) Determine the absorption spectrum of a solution of Flutamide in ethanol (95) (1 in 50,000) as directed under Ultraviolet-visible Spectrophotometry <2.24>, and compare the spectrum with the Reference Spectrum or the spectrum of a solution of Flutamide RS prepared in the same manner as the sample solution: both spectra exhibit similar intensities of absorption at the same wavelengths.

(2) Determine the infrared absorption spectrum of Flutamide as directed in the potassium bromide disk method under Infrared Spectrophotometry <2.25>, and compare the spectrum with the Reference Spectrum or the spectrum of Flutamide RS: both spectra exhibit similar intensities of absorption at the same wave numbers.

Melting point <2.60> 109 – 113°C

Purity (1) Heavy metals <1.07>—Proceed with 2.0 g of

Flutamide according to Method 2, and perform the test. Prepare the control solution with 2.0 mL of Standard Lead Solution (not more than 10 ppm).

(2) Related substances—Dissolve 40 mg of Flutamide in 50 mL of methanol, and use this solution as the sample solution. Perform the test with 10 μ L of the sample solution as directed under Liquid Chromatography <2.01> according to the following conditions. Determine each peak area of the sample solution by the automatic integration method and calculate the amounts of them by the area percentage method: the amount of each peak other than flutamide is not more than 0.3%, and the total amount of the peaks other than flutamide is not more than 0.5%.

Operating conditions—

Column, column temperature, mobile phase and flow rate: Proceed as directed in the operating conditions in the Assay.

Detector: An ultraviolet absorption photometer (wavelength: 230 nm).

Time span of measurement: About 2 times as long as the retention time of flutamide, beginning after the solvent peak.

System suitability—

System performance: Proceed as directed in the system suitability in the Assay.

Test for required detectability: To 1 mL of the sample solution, add methanol to make 100 mL, and use this solution as the solution for system suitability test. Pipet 2 mL of the solution for system suitability test, and add methanol to make exactly 20 mL. Confirm that the peak area of flutamide obtained with 10 μ L of this solution is equivalent to 7 to 13% of that with 10 μ L of the solution for system suitability test.

System repeatability: When the test is repeated 6 times with 10 μ L of the solution for system suitability test under the above operating conditions, the relative standard deviation of the peak area of flutamide is not more than 2.0%.

Loss on drying <2.41> Not more than 0.5% (0.5 g, in vacuum, phosphorus (V) oxide, 60°C, 3 hours).

Residue on ignition <2.44> Not more than 0.1% (1 g, platinum crucible).

Assay Weigh accurately about 40 mg each of Flutamide and Flutamide RS, previously dried, and dissolve separately in methanol to make exactly 25 mL. Pipet 5 mL each of these solutions, add exactly 5 mL of the internal standard solution, add methanol to make 50 mL, and use these solutions as the sample solution and the standard solution, respectively. Perform the test with 10 μ L each of the sample solution and standard solution as directed under Liquid Chromatography <2.01> according to the following conditions, and calculate the ratios, Q_T and Q_S , of the peak height of flutamide to that of the internal standard.

$$\begin{aligned} \text{Amount (mg) of flutamide (C}_{11}\text{H}_{11}\text{F}_3\text{N}_2\text{O}_3) \\ = M_S \times Q_T/Q_S \end{aligned}$$

M_S : Amount (mg) of Flutamide RS taken

Internal standard solution—A solution of testosterone in methanol (9 in 10,000).

Operating conditions—

Detector: An ultraviolet absorption photometer (wavelength: 254 nm).

Column: A stainless steel column 3.9 mm in inside diameter and 30 cm in length, packed with octadecylsilanized silica gel for liquid chromatography (10 μ m in particle diameter).

Column temperature: A constant temperature of about

25°C.

Mobile phase: A mixture of methanol and 0.05 mol/L potassium dihydrogen phosphate TS (7:4).

Flow rate: Adjust so that the retention time of flutamide is about 12 minutes.

System suitability—

System performance: When the procedure is run with 10 µL of the standard solution under the above operating conditions, flutamide and the internal standard are eluted in this order with the resolution between these peaks being not less than 2.0.

System repeatability: When the test is repeated 6 times with 10 µL of the standard solution under the above operating conditions, the relative standard deviation of the peak area of flutamide is not more than 1.0%.

Containers and storage Containers—Tight containers.

Flutoprazepam

フルトプラゼパム

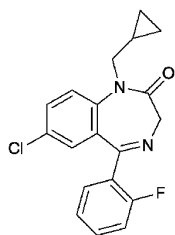

$C_{19}H_{16}ClFN_2O$: 342.79

7-Chloro-1-cyclopropylmethyl-5-(2-fluorophenyl)-1,3-dihydro-2H-1,4-benzodiazepin-2-one
[25967-29-7]

Flutoprazepam, when dried, contains not less than 99.0% and not more than 101.0% of flutoprazepam ($C_{19}H_{16}ClFN_2O$).

Description Flutoprazepam occurs as a white to light yellow, crystals or crystalline powder.

It is freely soluble in ethyl acetate, soluble in ethanol (99.5) and in acetic anhydride, and practically insoluble in water.

Identification (1) Dissolve 2 mg of Flutoprazepam in 200 mL of a solution of sulfuric acid in ethanol (99.5) (3 in 1000). Determine the absorption spectrum of this solution as directed under Ultraviolet-visible Spectrophotometry <2.24>, and compare the spectrum with the Reference Spectrum: both spectra exhibit similar intensities of absorption at the same wavelengths.

(2) Determine the infrared absorption spectrum of Flutoprazepam as directed in the potassium bromide disk method under Infrared Spectrophotometry <2.25>, and compare the spectrum with the Reference Spectrum: both spectra exhibit similar intensities of absorption at the same wave numbers.

(3) Perform the test with Flutoprazepam as directed under Flame Coloration Test <1.04> (2): a green color appears.

Melting point <2.60> 118 – 122°C

Purity (1) Chloride <1.03>—To 1.0 g of Flutoprazepam add 50 mL of water, allow to stand for 1 hour with occasional shaking, and filter. To 20 mL of the filtrate add 6 mL of dilute nitric acid and water to make 50 mL. Perform the test using this solution as the test solution. Prepare the con-

trol solution with 0.40 mL of 0.01 mol/L hydrochloric acid VS (not more than 0.036%).

(2) Heavy metals <1.07>—Proceed with 1.0 g of Flutoprazepam according to Method 2, and perform the test. Prepare the control solution with 1.0 mL of Standard Lead Solution (not more than 10 ppm).

(3) Related substances—Dissolve 0.10 g of Flutoprazepam in 20 mL of ethyl acetate, and use this solution as the sample solution. Pipet 1 mL of the sample solution, and add ethyl acetate to make exactly 50 mL. Pipet 1 mL of this solution, add ethyl acetate to make exactly 20 mL, and use this solution as the standard solution. Perform the test with these solutions as directed under Thin-layer Chromatography <2.03>. Spot 10 µL each of the sample solution and standard solution on a plate of silica gel with fluorescent indicator for thin-layer chromatography. Develop the plate with a mixture of ethyl acetate and hexane (3:2) to a distance of about 12 cm, and air-dry the plate. Examine under ultraviolet light (main wavelength: 254 nm): the spots other than the principal spot obtained from the sample solution are not more intense than the spot from the standard solution.

Loss on drying <2.41> Not more than 0.20% (1 g, 105°C, 2 hours).

Residue on ignition <2.44> Not more than 0.1% (1 g, platinum crucible).

Assay Weigh accurately about 0.5 g of Flutoprazepam, previously dried, dissolve in 70 mL of acetic anhydride, and titrate <2.50> with 0.1 mol/L perchloric acid VS (potentiometric titration). Perform a blank determination in the same manner, and make any necessary correction.

Each mL of 0.1 mol/L perchloric acid VS
= 34.28 mg of $C_{19}H_{16}ClFN_2O$

Containers and storage Containers—Well-closed containers.

Flutoprazepam Tablets

フルトプラゼパム錠

Flutoprazepam Tablets contain not less than 93.0% and not more than 107.0% of the labeled amount of flutoprazepam ($C_{19}H_{16}ClFN_2O$: 342.79).

Method of preparation Prepare as directed under Tablets, with Flutoprazepam.

Identification To a quantity of powdered Flutoprazepam Tablets, equivalent to 10 mg of Flutoprazepam, add 20 mL of a solution of sulfuric acid in ethanol (99.5) (3 in 1000), shake well, and add a solution of sulfuric acid in ethanol (99.5) (3 in 1000) to make 100 mL. Centrifuge this solution, to 10 mL of the supernatant liquid add a solution of sulfuric acid in ethanol (99.5) (3 in 1000) to make 100 mL. Determine the absorption spectrum of this solution as directed under Ultraviolet-visible Spectrophotometry <2.24>: it exhibits maxima between 240 nm and 244 nm, between 279 nm and 285 nm, and between 369 nm and 375 nm.

Uniformity of dosage units <6.02> Perform the test according to the following method: it meets the requirement of the Content uniformity test.

To 1 tablet of Flutoprazepam Tablets add 60 mL of the mobile phase, shake for 15 minutes to disintegrate, disperse the particle by sonicating, and add the mobile phase to make

exactly V mL so that each mL contains about $20\ \mu\text{g}$ of flutoprazepam ($\text{C}_{19}\text{H}_{16}\text{ClFN}_2\text{O}$). Filter this solution through a membrane filter with a pore size not exceeding $0.45\ \mu\text{m}$, discard the first 5 mL of the filtrate, and use the subsequent filtrate as the sample solution. Proceed as directed in the Assay.

$$\begin{aligned} \text{Amount (mg) of flutoprazepam (C}_{19}\text{H}_{16}\text{ClFN}_2\text{O)} \\ = M_S \times A_T/A_S \times V/1000 \end{aligned}$$

M_S : Amount (mg) of flutoprazepam for assay taken

Dissolution <6.10> When the test is performed at 50 revolutions per minute according to the Paddle method, using 900 mL of water as the dissolution medium, the dissolution rate in 90 minutes of Flutoprazepam Tablets is not less than 70%.

Start the test with 1 tablet of Flutoprazepam Tablets, withdraw not less than 20 mL of the medium at the specified minute after starting the test, and filter through a membrane filter with a pore size not exceeding $0.45\ \mu\text{m}$. Discard not less than 10 mL of the first filtrate, pipet V mL of the subsequent filtrate, add water to make exactly V' mL so that each mL contains about $2.2\ \mu\text{g}$ of flutoprazepam ($\text{C}_{19}\text{H}_{16}\text{ClFN}_2\text{O}$), and use this solution as the sample solution. Separately, weigh accurately about 22 mg of flutoprazepam for assay, previously dried at 105°C for 2 hours, and dissolve in methanol to make exactly 100 mL. Pipet 1 mL of this solution, add water to make exactly 100 mL, and use this solution as the standard solution. Perform the test with exactly $20\ \mu\text{L}$ each of the sample solution and standard solution as directed under Liquid Chromatography <2.01> according to the following conditions, and determine the peak areas, A_T and A_S , of flutoprazepam in each solution.

$$\begin{aligned} \text{Dissolution rate (\%)} \text{ with respect to the labeled amount} \\ \text{of flutoprazepam (C}_{19}\text{H}_{16}\text{ClFN}_2\text{O)} \\ = M_S \times A_T/A_S \times V'/V \times 1/C \times 9 \end{aligned}$$

M_S : Amount (mg) of flutoprazepam for assay taken

C : Labeled amount (mg) of flutoprazepam ($\text{C}_{19}\text{H}_{16}\text{ClFN}_2\text{O}$) in 1 tablet

Operating conditions—

Proceed as directed in the operating conditions in the Assay.

System suitability—

System performance: When the procedure is run with $20\ \mu\text{L}$ of the standard solution under the above operating conditions, the number of theoretical plates and the symmetry factor of the peak of flutoprazepam are not less than 4000 and not more than 1.5, respectively.

System repeatability: When the test is repeated 6 times with $20\ \mu\text{L}$ of the standard solution under the above operating conditions, the relative standard deviation of the peak area of flutoprazepam is not more than 1.0%.

Assay Weigh accurately not less than 20 Flutoprazepam Tablets, and powder. Weigh accurately a portion of the powder, equivalent to about 2 mg of flutoprazepam ($\text{C}_{19}\text{H}_{16}\text{ClFN}_2\text{O}$), add 60 mL of the mobile phase, shake for 15 minutes, and add the mobile phase to make exactly 100 mL. Filter this solution through a membrane filter with a pore size not exceeding $0.45\ \mu\text{m}$. Discard the first 5 mL of the filtrate, and use the subsequent filtrate as the sample solution. Separately, weigh accurately about 20 mg of flutoprazepam for assay, previously dried at 105°C for 2 hours, and dissolve in the mobile phase to make exactly 100 mL. Pipet 2 mL of this solution, add the mobile phase to make exactly 20 mL, and use this solution as the standard solution.

Perform the test with exactly $20\ \mu\text{L}$ each of the sample solution and standard solution as directed under Liquid Chromatography <2.01> according to the following conditions, and determine the peak areas, A_T and A_S , of flutoprazepam in each solution.

$$\begin{aligned} \text{Amount (mg) of flutoprazepam (C}_{19}\text{H}_{16}\text{ClFN}_2\text{O)} \\ = M_S \times A_T/A_S \times 1/10 \end{aligned}$$

M_S : Amount (mg) of flutoprazepam for assay taken

Operating conditions—

Detector: An ultraviolet absorption photometer (wavelength: 230 nm).

Column: A stainless steel column 4.6 mm in inside diameter and 15 cm in length, packed with octadecylsilanized silica gel for liquid chromatography ($5\ \mu\text{m}$ in particle diameter).

Column temperature: A constant temperature of about 40°C .

Mobile phase: A mixture of methanol and water (3:1).

Flow rate: Adjust so that the retention time of flutoprazepam is about 5 minutes.

System suitability—

System performance: When the procedure is run with $20\ \mu\text{L}$ of the standard solution under the above operating conditions, the number of theoretical plates and the symmetry factor of the peak of flutoprazepam are not less than 4000 and not more than 1.5, respectively.

System repeatability: When the test is repeated 6 times with $20\ \mu\text{L}$ of the standard solution under the above operating conditions, the relative standard deviation of the peak area of flutoprazepam is not more than 1.0%.

Containers and storage Containers—Well-closed containers.

Fluvoxamine Maleate

フルボキサミンマレイン酸塩

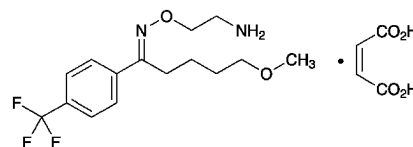

$\text{C}_{15}\text{H}_{21}\text{F}_3\text{N}_2\text{O}_2 \cdot \text{C}_4\text{H}_4\text{O}_4$: 434.41

5-Methoxy-1-[4-(trifluoromethyl)phenyl]pentan-1-one

(*E*)-*O*-(2-aminoethyl)oxime monomaleate

[61718-82-9]

Fluvoxamine Maleate contains not less than 98.0% and not more than 101.0% of fluvoxamine maleate ($\text{C}_{15}\text{H}_{21}\text{F}_3\text{N}_2\text{O}_2 \cdot \text{C}_4\text{H}_4\text{O}_4$), calculated on the dried basis.

Description Fluvoxamine Maleate occurs as a white crystalline powder.

It is freely soluble in ethanol (99.5), and sparingly soluble in water.

Identification (1) Dissolve 10 mg of Fluvoxamine Maleate in 5 mL of water, neutralize with dilute sodium hydroxide TS, then add 1 mL of ninhydrin TS, and heat in a water bath at $60 - 70^\circ\text{C}$ for 5 minutes: a blue-purple color develops.

(2) Determine the absorption spectrum of a solution of Fluvoxamine Maleate (1 in 50,000) as directed under Ultraviolet-visible Spectrophotometry <2.24>, and compare the spectrum with the Reference Spectrum or the spectrum of a

solution of Fluvoxamine Maleate RS prepared in the same manner as the sample solution: both spectra exhibit similar intensities of absorption at the same wavelengths.

(3) Determine the infrared absorption spectrum of Fluvoxamine Maleate as directed in the potassium bromide disk method under Infrared Spectrophotometry <2.25>, and compare the spectrum with the Reference Spectrum or the spectrum of Fluvoxamine Maleate RS: both spectra exhibit similar intensities of absorption at the same wave numbers.

(4) To 5 mL of a solution of Fluvoxamine Maleate (1 in 500) add 1 drop of potassium permanganate TS: the red color of the TS disappears immediately.

Melting point <2.60> 120 – 124°C

Purity (1) Clarity and color of solution—A solution obtained by dissolving 0.5 g of Fluvoxamine Maleate in 50 mL of water is clear and colorless.

(2) Chloride <1.03>—Perform the test with 1.0 g of Fluvoxamine Maleate. Prepare the control solution with 0.25 mL of 0.01 mol/L hydrochloric acid VS (not more than 0.009%).

(3) Sulfate <1.14>—Perform the test with 1.0 g of Fluvoxamine Maleate. Prepare the control solution with 0.35 mL of 0.005 mol/L sulfuric acid VS (not more than 0.017%).

(4) Heavy metals <1.07>—Proceed with 1.0 g of Fluvoxamine Maleate according to Method 2, using alumina ceramic crucible, and perform the test. Prepare the control solution with 2.0 mL of Standard Lead Solution (not more than 20 ppm).

(5) Related substances—Dissolve 20 mg of Fluvoxamine Maleate in 20 mL of a mixture of methanol for liquid chromatography and water (7:3), and use this solution as the sample solution. Pipet 1 mL of the sample solution, add a mixture of methanol for liquid chromatography and water (7:3) to make exactly 100 mL, and use this solution as the standard solution. Perform the test with exactly 10 µL each of the sample solution and standard solution as directed under Liquid Chromatography <2.01> according to the following conditions, and determine each peak area by the automatic integration method: the areas of the peaks, having the relative retention time of about 0.76, about 0.82, about 0.89, about 1.58 and about 1.66 to fluvoxamine, obtained from the sample solution are not larger than 1/5 times, 3/10 times, 7/10 times, 1/10 times and 1/10 times the peak area of fluvoxamine from the standard solution, respectively, and the total area of the peaks other than fluvoxamine from the sample solution is not larger than 1.5 times the peak area of fluvoxamine from the standard solution. For the areas of the peaks, having the relative retention times of about 0.76, about 0.89, about 1.58 and about 1.66 to fluvoxamine, multiply their correction factors, 0.87, 2.00, 0.67 and 2.76, respectively.

Operating conditions—

Detector: An ultraviolet absorption photometer (wavelength: 254 nm).

Column: A stainless steel column 4.6 mm in inside diameter and 25 cm in length, packed with octylsilylated silica gel for liquid chromatography (5 µm in particle diameter).

Column temperature: A constant temperature of about 25°C.

Mobile phase: Dissolve 12.67 g of diammonium hydrogen phosphate and 0.85 g of sodium 1-heptanesulfonate in 900 mL of water, adjust to pH 2.0 with phosphoric acid, and add water to make 1000 mL. To 300 mL of this solution add 700 mL of methanol for liquid chromatography.

Flow rate: Adjust so that the retention time of fluvoxa-

mine is about 9 minutes.

Time span of measurement: About 2 times as long as the retention time of fluvoxamine, beginning after the peak of maleic acid.

System suitability—

Test for required detectability: Pipet 1 mL of the standard solution, add a mixture of methanol for liquid chromatography and water (7:3) to make exactly 20 mL. Confirm that the peak area of fluvoxamine obtained with 10 µL of this solution is equivalent to 3.5 to 6.5% of that with 10 µL of the standard solution.

System performance: When the procedure is run with 10 µL of the standard solution under the above operating conditions, the number of theoretical plates and the symmetry factor of the peak of fluvoxamine are not less than 5000 and not more than 2.0, respectively.

System repeatability: When the test is repeated 6 times with 10 µL of the standard solution under the above operating conditions, the relative standard deviation of the peak area of fluvoxamine is not more than 2.0%.

Loss on drying <2.41> Not more than 0.1% (1 g, in vacuum, 50°C, 4 hours).

Residue on ignition <2.44> Not more than 0.1% (1 g, platinum crucible).

Assay Weigh accurately about 20 mg each of Fluvoxamine Maleate and Fluvoxamine Maleate RS (separately determine the loss on drying <2.41> under the same condition as Fluvoxamine Maleate), dissolve each in 10 mL of the mobile phase, add exactly 5 mL of the internal standard solution, then add the mobile phase to make 100 mL, and use these solutions as the sample solution and the standard solution, respectively. Perform the test with 20 µL each of the sample solution and standard solution as directed under Liquid Chromatography <2.01> according to the following conditions, and calculate the ratios, Q_T and Q_S , of the peak area of fluvoxamine to that of the internal standard.

$$\begin{aligned} &\text{Amount (mg) of fluvoxamine maleate} \\ &(\text{C}_{15}\text{H}_{21}\text{F}_3\text{N}_2\text{O}_2 \cdot \text{C}_4\text{H}_4\text{O}_4) \\ &= M_S \times Q_T / Q_S \end{aligned}$$

M_S : Amount (mg) of Fluvoxamine Maleate RS taken, calculated on the dried basis

Internal standard solution—A solution of diphenylamine in methanol (7 in 2000).

Operating conditions—

Detector: An ultraviolet absorption photometer (wavelength: 254 nm).

Column: A stainless steel column 4.6 mm in inside diameter and 25 cm in length, packed with octylsilylated silica gel for liquid chromatography (5 µm in particle diameter).

Column temperature: A constant temperature of about 25°C.

Mobile phase: Dissolve 3.8 g of diammonium hydrogen phosphate and 0.8 g of sodium 1-heptanesulfonate in water to make 300 mL, add 700 mL of methanol, and adjust to pH 3.5 with phosphoric acid.

Flow rate: Adjust so that the retention time of fluvoxamine is about 9 minutes.

System suitability—

System performance: When the procedure is run with 20 µL of the standard solution under the above operating conditions, fluvoxamine and the internal standard are eluted in this order with the resolution between these peaks being not less than 8.

System repeatability: When the test is repeated 6 times

with 20 μL of the standard solution under the above operating conditions, the relative standard deviation of the ratio of the peak area of fluvoxamine to that of the internal standard is not more than 1.0%.

Containers and storage Containers—Well-closed containers.

Fluvoxamine Maleate Tablets

フルボキサミンマレイン酸塩錠

Fluvoxamine Maleate Tablets contain not less than 95.0% and not more than 105.0% of the labeled amount of fluvoxamine maleate ($\text{C}_{15}\text{H}_{21}\text{F}_3\text{N}_2\text{O}_2 \cdot \text{C}_4\text{H}_4\text{O}_4$; 434.41).

Method of preparation Prepare as directed under Tablets, with Fluvoxamine Maleate.

Identification Powder Fluvoxamine Maleate Tablets. To a portion of the powder, equivalent to 0.1 g of Fluvoxamine Maleate, add 50 mL of water, shake, then allow to stand, and filter the supernatant liquid through a membrane filter with a pore size not exceeding 0.45 μm . To 0.5 mL of the filtrate add 50 mL of water, and determine the absorption spectrum of this solution as directed under Ultraviolet-visible Spectrophotometry <2.24>: it exhibits a maximum between 243 nm and 247 nm.

Uniformity of dosage units <6.02> Perform the Mass variation test, or the Content uniformity test according to the following method: it meets the requirement.

To 1 tablet of Fluvoxamine Maleate Tablets add 4 mL of water, disintegrate the tablet by sonicating, add a mixture of methanol for liquid chromatography and water (7:3) to make exactly 50 mL, and filter. Pipet V mL of the filtrate, equivalent to about 6 mg of fluvoxamine maleate ($\text{C}_{15}\text{H}_{21}\text{F}_3\text{N}_2\text{O}_2 \cdot \text{C}_4\text{H}_4\text{O}_4$), add exactly 2 mL of the internal standard solution, then add a mixture of methanol for liquid chromatography and water (7:3) to make 50 mL, and use this solution as the sample solution. Then, proceed as directed in the Assay.

$$\begin{aligned} &\text{Amount (mg) of fluvoxamine maleate} \\ &(\text{C}_{15}\text{H}_{21}\text{F}_3\text{N}_2\text{O}_2 \cdot \text{C}_4\text{H}_4\text{O}_4) \\ &= M_S \times Q_T/Q_S \times 6/V \end{aligned}$$

M_S : Amount (mg) of Fluvoxamine Maleate RS taken, calculated on the dried basis

Internal standard solution—A solution of diphenylamine in methanol for liquid chromatography (3 in 1000).

Dissolution <6.10> When the test is performed at 50 revolutions per minute according to the Paddle method, using 900 mL of water as the dissolution medium, the dissolution rate in 20 minutes of Fluvoxamine Maleate Tablets is not less than 80%.

Start the test with 1 tablet of Fluvoxamine Maleate Tablets, withdraw not less than 20 mL of the medium at the specified minute after starting the test, and filter through a membrane filter with a pore size not exceeding 0.45 μm . Discard not less than 10 mL of the first filtrate, pipet V mL of the subsequent filtrate, add water to make exactly V' mL so that each mL contains about 20 μg of fluvoxamine maleate ($\text{C}_{15}\text{H}_{21}\text{F}_3\text{N}_2\text{O}_2 \cdot \text{C}_4\text{H}_4\text{O}_4$), and use this solution as the sample solution. Separately, weigh accurately about 20 mg of Fluvoxamine Maleate RS (separately determine the loss

on drying <2.41> under the same condition as Fluvoxamine Maleate), and dissolve in water to make exactly 100 mL. Pipet 5 mL of this solution, add water to make exactly 50 mL, and use this solution as the standard solution. Determine the absorbances, A_T and A_S , at 245 nm of the sample solution and standard solution as directed under Ultraviolet-visible Spectrophotometry <2.24>.

$$\begin{aligned} &\text{Dissolution rate (\%)} \text{ with respect to the labeled amount} \\ &\text{of fluvoxamine maleate } (\text{C}_{15}\text{H}_{21}\text{F}_3\text{N}_2\text{O}_2 \cdot \text{C}_4\text{H}_4\text{O}_4) \\ &= M_S \times A_T/A_S \times V'/V \times 1/C \times 90 \end{aligned}$$

M_S : Amount (mg) of Fluvoxamine Maleate RS taken, calculated on the dried basis

C : Labeled amount (mg) of fluvoxamine maleate ($\text{C}_{15}\text{H}_{21}\text{F}_3\text{N}_2\text{O}_2 \cdot \text{C}_4\text{H}_4\text{O}_4$) in 1 tablet

Assay To 10 Fluvoxamine Maleate Tablets add 20 mL of water, disintegrate the tablets by sonicating, then add a mixture of methanol for liquid chromatography and water (7:3) to make exactly 250 mL, and filter. Pipet V mL of the filtrate, equivalent to about 6 mg of fluvoxamine maleate ($\text{C}_{15}\text{H}_{21}\text{F}_3\text{N}_2\text{O}_2 \cdot \text{C}_4\text{H}_4\text{O}_4$), add exactly 2 mL of the internal standard solution, then add a mixture of methanol for liquid chromatography and water (7:3) to make 50 mL, and use this solution as the sample solution. Separately, weigh accurately about 50 mg of Fluvoxamine Maleate RS (separately determine the loss on drying <2.41> under the same condition as Fluvoxamine Maleate), and dissolve in a mixture of methanol for liquid chromatography and water (7:3) to make exactly 25 mL. Pipet 3 mL of this solution, add exactly 2 mL of the internal standard solution, then add a mixture of methanol for liquid chromatography and water (7:3) to make exactly 50 mL, and use this solution as the standard solution. Perform the test with 20 μL each of the sample solution and standard solution as directed under Liquid Chromatography <2.01> according to the following conditions, and calculate the ratios, Q_T and Q_S , of the peak area of fluvoxamine to that of the internal standard.

$$\begin{aligned} &\text{Amount (mg) of fluvoxamine maleate} \\ &(\text{C}_{15}\text{H}_{21}\text{F}_3\text{N}_2\text{O}_2 \cdot \text{C}_4\text{H}_4\text{O}_4) \text{ in 1 tablet} \\ &= M_S \times Q_T/Q_S \times 3/V \end{aligned}$$

M_S : Amount (mg) of Fluvoxamine Maleate RS taken, calculated on the dried basis

Internal standard solution—A solution of diphenylamine in methanol for liquid chromatography (3 in 1000).

Operating conditions—

Proceed as directed in the operating conditions in the Assay under Fluvoxamine Maleate.

System suitability—

System performance: When the procedure is run with 20 μL of the standard solution under the above operating conditions, fluvoxamine and the internal standard are eluted in this order with the resolution between these peaks being not less than 8.

System repeatability: When the test is repeated 6 times with 20 μL of the standard solution under the above operating conditions, the relative standard deviation of the ratio of the peak area of fluvoxamine to that of the internal standard is not more than 1.0%.

Containers and storage Containers—Tight containers.

Folic Acid

葉酸

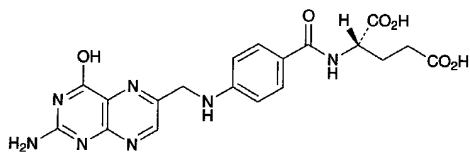
 $C_{19}H_{19}N_7O_6$; 441.40

N-[4-[(2-Amino-4-hydroxypteridin-6-ylmethyl)amino]benzoyl]-L-glutamic acid
[59-30-3]

Folic Acid contains not less than 98.0% and not more than 102.0% of folic acid ($C_{19}H_{19}N_7O_6$), calculated on the anhydrous basis.

Description Folic Acid occurs as a yellow to orange-yellow crystalline powder. It is odorless.

It is practically insoluble in water, in methanol, in ethanol (95), in pyridine and in diethyl ether.

It dissolves in hydrochloric acid, in sulfuric acid, in dilute sodium hydroxide TS and in a solution of sodium carbonate decahydrate (1 in 100), and these solutions are yellow in color.

It is slowly affected by light.

Identification (1) Dissolve 1.5 mg of Folic Acid in dilute sodium hydroxide TS to make 100 mL. Determine the absorption spectrum of the solution as directed under Ultraviolet-visible Spectrophotometry <2.24>, and compare the spectrum with the Reference Spectrum or the spectrum of a solution of Folic Acid RS prepared in the same manner as the sample solution: both spectra exhibit similar intensities of absorption at the same wavelengths.

(2) To 10 mL of the solution obtained in (1) add 1 drop of potassium permanganate TS, and mix well until the color changes to blue, and immediately observe under ultraviolet light (main wavelength: 365 nm): a blue fluorescence is produced.

Purity (1) Clarity and color of solution—Dissolve 0.10 g of Folic Acid in 10 mL of dilute sodium hydroxide TS: the solution is clear and yellow in color.

(2) Free amines—Pipet 30 mL of the sample solution obtained in the Assay, add 20 mL of dilute hydrochloric acid and water to make exactly 100 mL, and use this solution as the sample solution. Separately, weigh accurately about 50 mg of *p*-Aminobenzoyl Glutamic Acid for Purity RS, previously dried in a desiccator (in vacuum, silica gel) for 4 hours, dissolve in diluted ethanol (2 in 5) to make exactly 100 mL. Pipet 3 mL of this solution, add water to make exactly 1000 mL, and use this solution as the standard solution. Pipet 4 mL each of the sample solution and standard solution, proceed as directed in the Assay, and perform the test as directed under Ultraviolet-visible Spectrophotometry <2.24>. Determine the absorbances, A_T and A_S , of subsequent solutions of the sample solution and standard solution at 550 nm: the content of free amines is not more than 1.0%.

$$\text{Content (\%)} \text{ of free amines} = M_S/M_T \times A_T/A_S$$

M_S : Amount (mg) of *p*-Aminobenzoyl Glutamic Acid for Purity RS taken

M_T : Amount (mg) of Folic Acid taken, calculated on the anhydrous basis

Water <2.48> Not more than 8.5% (10 mg, coulometric titration).

Residue on ignition <2.44> Not more than 0.5% (1 g).

Assay Weigh accurately about 50 mg each of Folic Acid and Folic Acid RS (separately, determine the water <2.48> in the same manner as Folic Acid). To each add 50 mL of dilute sodium hydroxide TS, mix well to dissolve, add dilute sodium hydroxide TS to make exactly 100 mL, and use these solutions as the sample solution and standard solution. To 30 mL each of these solutions, accurately measured, add 20 mL of dilute hydrochloric acid and water to make exactly 100 mL. Pipet 60 mL each of these solutions add 0.5 g of zinc powder, and allow to stand with frequent shaking for 20 minutes. Filter each mixture through a dry filter paper, and discard the first 10 mL of the filtrate. Pipet 10 mL each of the subsequent filtrate, and add water to make exactly 100 mL. To 4 mL each of solutions, accurately measured, add 1 mL of water, 1 mL of dilute hydrochloric acid and 1 mL of a solution of sodium nitrite (1 in 1000), mix well, and allow to stand for 2 minutes. To each solution add 1 mL of a solution of ammonium amidosulfate (1 in 200), mix thoroughly, and allow to stand for 2 minutes. To each of these solutions, add 1 mL of a solution of *N*-(1-naphthyl)-*N'*-diethylethylenediamine oxalate (1 in 1000), shake, allow to stand for 10 minutes, and add water to make exactly 20 mL. Separately, to 30 mL of the sample solution, accurately measured, add 20 mL of dilute hydrochloric acid and water to make exactly 100 mL. Pipet 10 mL of this solution, add 18 mL of dilute hydrochloric acid and water to make exactly 100 mL. Pipet 4 mL of this solution, and prepare the blank solution in the same manner as the sample solution. Perform the test with these solutions as directed under Ultraviolet-visible Spectrophotometry <2.24>, using a solution prepared with 4 mL of water in the same manner as a blank. Determine the absorbances, A_T , A_S and A_C , of the subsequent solution of the sample solution, the standard solution and the blank solution at 550 nm.

$$\begin{aligned} \text{Amount (mg) of folic acid (C}_{19}\text{H}_{19}\text{N}_7\text{O}_6) \\ = M_S \times (A_T - A_C)/A_S \end{aligned}$$

M_S : Amount (mg) of Folic Acid RS taken, calculated on the anhydrous basis

Containers and storage Containers—Tight containers.

Storage—Light-resistant.

Folic Acid Injection

葉酸注射液

Folic Acid Injection is an aqueous injection.

It contains not less than 95.0% and not more than 115.0% of the labeled amount of folic acid ($C_{19}H_{19}N_7O_6$; 441.40).

Method of preparation Dissolve Folic Acid in water with the aid of Sodium Hydroxide or Sodium Carbonate, and prepare as directed under Injections.

Description Folic Acid Injection is a yellow to orange-yellow, clear liquid.

pH: 8.0 – 11.0

Identification (1) To a volume of Folic Acid Injection, equivalent to 1.5 mg of Folic Acid, add dilute sodium hydroxide TS to make 100 mL. Proceed as directed in the Ident-

tification (2) under Folic Acid, using this solution as the sample solution.

(2) Determine the absorption spectrum of the sample solution obtained in (1) as directed under Ultraviolet-visible Spectrophotometry <2.24>: it exhibits maxima between 255 nm and 257 nm, between 281 nm and 285 nm and between 361 nm and 369 nm. Separately, determine the maximal absorbances of the sample solution, A_1 and A_2 , between 255 nm and 257 nm and between 361 nm and 369 nm, respectively: the ratio of A_1/A_2 is between 2.80 and 3.00.

(3) Folic Acid Injection responds to Qualitative Tests <1.09> (1) for sodium salt.

Extractable volume <6.05> It meets the requirement.

Foreign insoluble matter <6.06> Perform the test according to Method 1: it meets the requirement.

Insoluble particulate matter <6.07> It meets the requirement.

Sterility <4.06> Perform the test according to the Membrane filtration method: it meets the requirement.

Assay To an exactly measured volume of Folic Acid Injection, equivalent to about 50 mg of folic acid ($C_{19}H_{19}N_7O_6$) add dilute sodium hydroxide TS to make exactly 100 mL, and use this solution as the sample solution. Separately, weigh accurately about 50 mg of Folic Acid RS (separately, determine the water <2.48> in the same manner as Folic Acid), dissolve in dilute sodium hydroxide TS to make exactly 100 mL, and use this solution as the standard solution. Proceed with exactly 30 mL each of the sample solution and standard solution as directed in the Assay under Folic Acid.

$$\begin{aligned} &\text{Amount (mg) of folic acid (C}_{19}\text{H}_{19}\text{N}_7\text{O}_6) \\ &= M_S \times (A_T - A_C)/A_S \end{aligned}$$

M_S : Amount (mg) of Folic Acid RS taken, calculated on the anhydrous basis

Containers and storage Containers—Hermetic containers, and colored containers may be used.

Storage—Light-resistant.

Folic Acid Tablets

葉酸錠

Folic Acid Tablets contain not less than 90.0% and not more than 115.0% of the labeled amount of folic acid ($C_{19}H_{19}N_7O_6$; 441.40).

Method of preparation Prepare as directed under Tablets, with Folic Acid.

Identification (1) Take a quantity of powdered Folic Acid Tablets, equivalent to 1.5 mg of Folic Acid, add 100 mL of dilute sodium hydroxide TS, shake, and filter. Discard the first 10 mL of the filtrate, use the subsequent filtrate as the sample solution, and proceed as directed in the Identification (2) under Folic Acid.

(2) Determine the absorption spectrum of the filtrate obtained in (1) as directed under Ultraviolet-visible Spectrophotometry <2.24>: it exhibits maxima between 255 nm and 257 nm, between 281 nm and 285 nm and between 361 nm and 369 nm. Separately, determine the maximal absorbances of the filtrate, A_1 and A_2 , between 255 nm and 257 nm and between 361 nm and 369 nm, respectively: the ratio of A_1/A_2

is between 2.80 and 3.00.

Uniformity of dosage units <6.02> Perform the test according to the following method: it meets the requirement of the Content uniformity test.

To 1 tablet of Folic Acid Tablets add 50 mL of dilute sodium hydroxide TS, shake frequently, and filter. Wash the residue with dilute sodium hydroxide TS, combine the filtrate and the washings, then add dilute sodium hydroxide TS to make exactly 100 mL, and use this solution as the sample stock solution. Pipet 30 mL of the sample stock solution, add 20 mL of dilute hydrochloric acid and water to make exactly 100 mL. Pipet 60 mL of this solution, add 0.5 g of zinc powder, shake frequently, allow to stand for 20 minutes, and filter the solution through a dried filter paper. Discard the first 10 mL of the filtrate, pipet V mL of the subsequent filtrate, add water to make exactly V' mL so that each mL contains about 15 μ g of folic acid ($C_{19}H_{19}N_7O_6$), and use this solution as the sample solution. Separately, weigh accurately about 50 mg of Folic Acid RS (separately determine the water <2.48> in the same manner as Folic Acid), and dissolve in dilute sodium hydroxide TS to make exactly 100 mL. Pipet 30 mL of this solutions, add 20 mL of dilute hydrochloric acid and water to make exactly 100 mL. Pipet 60 mL of this solution, add 0.5 g of zinc powder, shake frequently, allow to stand for 20 minutes, and filter the solution through a dried filter paper. Discard the first 10 mL of the filtrate, pipet 10 mL of the subsequent filtrate, add water to make exactly 100 mL, and use this solution as the standard solution. Pipet 4 mL each of the sample solution and standard solution, add 1 mL of water, 1 mL of dilute hydrochloric acid and 1 mL of sodium nitrite solution (1 in 1000) to them, mix, and allow to stand for 2 minutes. To these solutions add 1 mL of a solution of ammonium amidosulfate (1 in 200), shake, and allow them to stand for 2 minutes. To these solutions add 1 mL of a solution of *N,N*-diethyl-*N'*-1-naphthylethylenediamine oxalate (1 in 1000), shake, allow to stand for 10 minutes, and add water to make exactly 20 mL. Separately, pipet 30 mL of the sample stock solution, add 20 mL of dilute hydrochloric acid, and add water to make exactly 100 mL. Pipet V mL of this solution, and add water to make exactly V' mL so that each mL contains about 15 μ g of folic acid ($C_{19}H_{19}N_7O_6$). With exactly 4 mL of this solution perform the same procedure described above for obtaining the sample solution, and use the solution so obtained as the blank solution. Determine the absorbances at 550 nm, A_T , A_S and A_C , of the solutions obtained from the sample solution and standard solution, and the blank solution as directed under Ultraviolet-visible Spectrophotometry <2.24>, using a control solution obtained with 4 mL of water in the same manner as described above.

$$\begin{aligned} &\text{Amount (mg) of folic acid (C}_{19}\text{H}_{19}\text{N}_7\text{O}_6) \\ &= M_S \times (A_T - A_C)/A_S \times V'/V \times 1/10 \end{aligned}$$

M_S : Amount (mg) of Folic Acid RS taken, calculated on the anhydrous basis

Dissolution <6.10> When the test is performed at 50 revolutions per minute according to the Paddle method, using 900 mL of water as the dissolution medium, the dissolution rate in 45 minutes of Folic Acid Tablets is not less than 75%.

Start the test with 1 tablet of Folic Acid Tablets, withdraw not less than 20 mL of the medium at the specified minute after starting the test, and filter through a membrane filter with a pore size not exceeding 0.45 μ m. Discard not less than 10 mL of the first filtrate, pipet V mL of the subsequent filtrate, add water to make exactly V' mL so that each mL contains about 5.6 μ g of folic acid ($C_{19}H_{19}N_7O_6$), and use this

solution as the sample solution. Separately, weigh accurately about 20 mg of Folic Acid RS (separately determine the water <2.48> in the same manner as Folic Acid), and dissolve in the 2nd fluid for dissolution test to make exactly 100 mL. Pipet 2.5 mL of this solution, add the 2nd fluid for dissolution test to make exactly 100 mL, and use this solution as the standard solution. Determine the absorbances, A_T and A_S , at 280 nm of the sample solution and standard solution as directed under Ultraviolet-visible Spectrophotometry <2.24>, using water as the blank.

Dissolution rate (%) with respect to the labeled amount of folic acid ($C_{19}H_{19}N_7O_6$)

$$= M_S \times A_T / A_S \times V' / V \times 1 / C \times 45 / 2$$

M_S : Amount (mg) of Folic Acid RS taken, calculated on the anhydrous basis

C : Labeled amount (mg) of folic acid ($C_{19}H_{19}N_7O_6$) in 1 tablet

Assay Weigh accurately and powder not less than 20 Folic Acid Tablets. Weigh accurately a portion of the powder, equivalent to about 50 mg of folic acid ($C_{19}H_{19}N_7O_6$). Add 50 mL of dilute sodium hydroxide TS, shake frequently, then filter into a 100-mL volumetric flask, and wash with dilute sodium hydroxide TS. To the combined filtrate and washings add dilute sodium hydroxide TS to make exactly 100 mL, and use this solution as the sample solution. Separately, weigh accurately about 50 mg of Folic Acid RS (separately, determine the water <2.48> in the same manner as Folic Acid), dissolve in dilute sodium hydroxide TS to make exactly 100 mL, and use this solution as the standard solution. Proceed with exactly 30 mL each of the sample solution and standard solution as directed in the Assay under Folic Acid.

Amount (mg) of folic acid ($C_{19}H_{19}N_7O_6$)

$$= M_S \times (A_T - A_C) / A_S$$

M_S : Amount (mg) of Folic Acid RS taken, calculated on the anhydrous basis

Containers and storage Containers—Well-closed containers.

Storage—Light-resistant.

Formalin

ホルマリン

Formalin contains not less than 35.0% and not more than 38.0% of formaldehyde (CH_2O : 30.03.)

It contains 5% to 13% of methanol to prevent polymerization.

Description Formalin is a clear, colorless liquid. Its vapor is irritating to the mucous membrane.

It is miscible with water and with ethanol (95).

When stored for a long time, especially in a cold place, it may become cloudy.

Identification (1) Dilute 2 mL of Formalin with 10 mL of water in a test tube, and add 1 mL of silver nitrate-ammonia TS: a gray precipitate is produced, or a silver mirror is formed on the wall of the test tube.

(2) To 5 mL of sulfuric acid in which 0.1 g of salicylic acid has been dissolved add 2 drops of Formalin, and warm the solution: a persistent, dark red color develops.

Purity Acidity—Dilute 20 mL of Formalin with 20 mL of

water, and add 5.0 mL of 0.1 mol/L sodium hydroxide VS and 2 drops of bromothymol blue TS: a blue color develops.

Residue on ignition <2.44> Not more than 0.06 w/v% (5 mL, after evaporation).

Assay Weigh accurately a weighing bottle containing 5 mL of water, add about 1 g of Formalin, and weigh accurately again. Add water to make exactly 100 mL. Pipet 10 mL of this solution, add exactly 50 mL of 0.05 mol/L iodine VS and 20 mL of potassium hydroxide TS, and allow to stand for 15 minutes at an ordinary temperature. To this mixture add 15 mL of dilute sulfuric acid, and titrate <2.50> the excess iodine with 0.1 mol/L sodium thiosulfate VS (indicator: 1 mL of starch TS). Perform a blank determination in the same manner.

Each mL of 0.05 mol/L iodine VS = 1.501 mg of CH_2O

Containers and storage Containers—Tight containers.

Storage—Light-resistant.

Formalin Water

ホルマリン水

Formalin Water contains not less than 0.9 w/v% and not more than 1.1 w/v% of formaldehyde (CH_2O : 30.03).

Method of preparation

Formalin	30 mL
Water, Purified Water or Purified Water in Containers	a sufficient quantity
To make 1000 mL	

Prepare by mixing the above ingredients.

Description Formalin Water is a clear, colorless liquid. It has a slight odor of formaldehyde.

It is almost neutral.

Assay Transfer 20 mL of Formalin Water, measured exactly, to a 100-mL volumetric flask containing 2.5 mL of 1 mol/L sodium hydroxide VS, and add water to make 100 mL. Pipet 10 mL of this solution, and proceed as directed in the Assay under Formalin.

Each mL of 0.05 mol/L iodine VS = 1.501 mg of CH_2O

Containers and storage Containers—Tight containers.

Formoterol Fumarate Hydrate

ホルモテロール fumarate 水和物

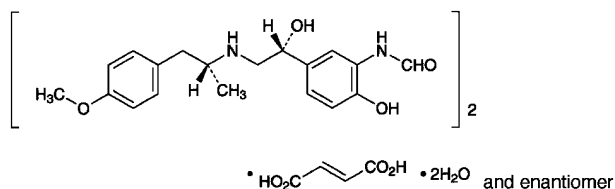

(C₁₉H₂₄N₂O₄)₂·C₄H₄O₄·2H₂O: 840.91
N-(2-Hydroxy-5-((1*R*,*S*)-1-hydroxy-2-((1*R*,*S*)-2-(4-methoxyphenyl)-1-methylethylamino)ethyl)phenyl)formamide hemifumarate monohydrate
 [43229-80-7, anhydride]

Formoterol Fumarate Hydrate contains not less than 98.5% of formoterol fumarate [(C₁₉H₂₄N₂O₄)₂·C₄H₄O₄: 804.88], calculated on the anhydrous basis.

Description Formoterol Fumarate Hydrate occurs as a white to yellowish white crystalline powder.

It is freely soluble in acetic acid (100), soluble in methanol, very slightly soluble in water and in ethanol (95), and practically insoluble in diethyl ether.

A solution of Formoterol Fumarate Hydrate in methanol (1 in 100) shows no optical rotation.

Melting point: about 138°C (with decomposition).

Identification (1) Dissolve 0.5 g of Formoterol Fumarate Hydrate in 20 mL of 0.5 mol/L sulfuric acid TS, and extract with three 25-mL portions of diethyl ether. Wash the combined diethyl ether extracts with 10 mL of 0.5 mol/L sulfuric acid TS, and evaporate the ether layer under reduced pressure, and dry the residue at 105°C for 3 hours: the residue melts <2.60> at about 290°C (with decomposition, in a sealed tube).

(2) Determine the absorption spectrum of a solution of Formoterol Fumarate Hydrate in methanol (1 in 40,000) as directed under Ultraviolet-visible Spectrophotometry <2.24>, and compare the spectrum with the Reference Spectrum: both spectra exhibit similar intensities of absorption at the same wavelengths.

(3) Determine the infrared absorption spectrum of Formoterol Fumarate Hydrate as directed in the potassium bromide disk method under Infrared Spectrophotometry <2.25>, and compare the spectrum with the Reference Spectrum: both spectra exhibit similar intensities of absorption at the same wave numbers.

Purity (1) Heavy metals <1.07>—Proceed with 1.0 g of Formoterol Fumarate Hydrate according to Method 2, and perform the test. Prepare the control solution with 2.0 mL of Standard Lead Solution (not more than 20 ppm).

(2) Related Substances—Dissolve 0.20 g of Formoterol Fumarate Hydrate in 10 mL of methanol, and use this solution as the sample solution. Pipet 1 mL of the sample solution, add methanol to make exactly 200 mL, and use this solution as the standard solution. Perform the test with these solutions as directed under Thin-layer Chromatography <2.03>. Spot 5 μL each of the sample solution and standard solution on a plate of silica gel for thin-layer chromatography. Develop the plate with a mixture of chloroform, 1,4-dioxane, ethanol (99.5) and ammonia solution (28) (20:20:10:3) to a distance of about 12 cm, and air-dry the

plate. Allow the plate to stand for 5 minutes in iodine vapor: the spots other than the principal spot obtained from the sample solution are not more intense than the spot from the standard solution.

Water <2.48> 4.0 – 5.0% (0.5 g, volumetric titration, direct titration).

Residue on ignition <2.44> Not more than 0.1% (1 g).

Assay Weigh accurately about 0.7 g of Formoterol Fumarate Hydrate, dissolve in 50 mL of acetic acid (100), and titrate <2.50> with 0.1 mol/L perchloric acid VS (potentiometric titration). Perform a blank determination in the same manner, and make any necessary correction.

Each mL of 0.1 mol/L perchloric acid VS
 = 40.24 mg of (C₁₉H₂₄N₂O₄)₂·C₄H₄O₄

Containers and storage Containers—Tight containers.

Fosfomycin Calcium Hydrate

ホスホマイシンカルシウム水和物

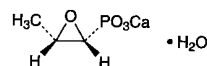

C₃H₅CaO₄P·H₂O: 194.14
 Monocalcium (2*R*,3*S*)-3-methyloxiran-2-ylphosphonate monohydrate
 [26016-98-8]

Fosfomycin Calcium Hydrate is the calcium salt of a substance having antibacterial activity produced by the growth of *Streptomyces fradiae* or by the chemical synthesis.

It contains not less than 725 μg (potency) and not more than 805 μg (potency) per mg, calculated on the anhydrous basis. The potency of Fosfomycin Calcium Hydrate is expressed as mass (potency) of fosfomycin (C₃H₇O₄P: 138.06).

Description Fosfomycin Calcium Hydrate occurs as a white crystalline powder.

It is slightly soluble in water, and practically insoluble in methanol and in ethanol (99.5).

Identification (1) Determine the infrared absorption spectrum of Fosfomycin Calcium Hydrate as directed in the potassium bromide disk method under Infrared Spectrophotometry <2.25>, and compare the spectrum with the Reference Spectrum: both spectra exhibit similar intensities of absorption at the same wave numbers.

(2) Determine the ¹H spectrum of a solution of Fosfomycin Calcium Hydrate in heavy water for nuclear magnetic resonance spectroscopy (1 in 300), using sodium 3-trimethylsilylpropanesulfonate for nuclear magnetic resonance spectroscopy as an internal reference compound, as directed under Nuclear Magnetic Resonance Spectroscopy <2.21>: it exhibits a double signal at around δ 1.5 ppm, a double signal at around δ 2.9 ppm, a multiple signal at around δ 3.3 ppm, and no signal at around δ 1.4 ppm.

(3) A solution of Fosfomycin Calcium Hydrate (1 in 500) responds to Qualitative Tests <1.09> (3) for calcium salt.

Optical rotation <2.49> [α]_D²⁰: –2.5 – –5.4° (0.5 g calculated on the anhydrous bases, 0.4 mol/L disodium dihydrogen ethylenediamine tetraacetate TS (pH 8.5), 10 mL, 100 mm).

Phosphorus Content Weigh accurately about 0.1 g of Fosfomycin Calcium Hydrate, add 40 mL of sodium periodate (107 in 10,000) and 2 mL of perchloric acid, and heat in a water bath for 1 hour. After cooling, add water to make exactly 200 mL. Pipet 10 mL of this solution, and add 1 mL of potassium iodide TS. To this solution add sodium thiosulfate TS until the solution is colorless, add water to make exactly 100 mL, and use this solution as the sample stock solution. Separately, weigh accurately about 70 mg of potassium dihydrogen phosphate, proceed with this solution in the same manner as directed for the preparation of the sample stock solution, and use the solution so obtained as the standard stock solution. Proceed and prepare a solution in the same manner for the preparation of the sample stock solution without using Fosfomycin Calcium Hydrate, and use the solution so obtained as the blank stock solution. Pipet 5 mL each of the sample stock solution, the standard stock solution, and the blank stock solution, add 2.5 mL of ammonium molybdate-sulfuric acid TS and 1 mL of 1-amino-2-naphthol-4-sulfonic acid TS, mix, and add water to make exactly 25 mL, and use these solutions as the sample solution, the standard solution, and the blank solution, respectively. After allowing these solutions to stand at $20 \pm 1^\circ\text{C}$ for 30 minutes, perform the test with these solutions as directed under Ultraviolet-visible Spectrophotometry <2.24>, using water as a blank, and determine the absorbances at 740 nm, A_T , A_S and A_B , of the sample solution, the standard solution and the blank solution: the content of phosphorus is 15.2 – 16.7%.

$$\begin{aligned} &\text{Amount (mg) of phosphorus (P)} \\ &= M_S \times (A_T - A_B) / (A_S - A_B) \times 0.228 \end{aligned}$$

M_S : Amount (mg) of potassium dihydrogen phosphate taken

Calcium Content Weigh accurately about 0.2 g of Fosfomycin Calcium Hydrate, add 4 mL of 1 mol/L Hydrochloric acid TS, and shake well until the sample is completely dissolved. To this solution add 100 mL of water, 9 mL of sodium hydroxide TS and 0.1 g of methylthymol blue-sodium chloride indicator, and titrate <2.50> with 0.05 mol/L disodium dihydrogen ethylenediamine tetraacetate VS until the color of the solution changes from clear blue to gray or gray-purple: calcium content is 19.6 – 21.7%. Perform a blank determination in the same manner, and make any necessary correction.

Each mL of 0.05 mol/L disodium dihydrogen ethylenediamine tetraacetate VS = 2.004 mg of Ca

Purity (1) Heavy metals <1.07>—To 1.0 g of Fosfomycin Calcium Hydrate add 40 mL of 0.25 mol/L acetic acid TS and water to make 50 mL. Proceed with this solution according to Method 1, and perform the test. Prepare the control solution with 2.0 mL of Standard Lead Solution (not more than 20 ppm).

(2) Arsenic <1.11>—Prepare the test solution with 1.0 g of Fosfomycin Calcium Hydrate according to Method 3, and perform the test (not more than 2 ppm).

(3) Glycol substance—Weigh accurately about 0.2 g of Fosfomycin Calcium Hydrate, transfer into a 250-mL iodine flask, add 100 mL of water, and dissolve by sonicating while cooling in ice. Add exactly 50 mL of phthalate buffer solution (pH 5.8) and exactly 5 mL of sodium periodate solution (107 in 100,000), stopper, stir, and add 1 mL of water in the receiving part. Avoid exposure to light, allow to stand in a water bath at 30°C for 60 minutes, add exactly 10 mL of a solution of potassium iodide (2 in 5) without haste, and

titrate <2.50> with 0.01 mol/L sodium thiosulfate VS (indicator: 2 mL of starch TS). Perform a blank determination in the same manner, and make any necessary correction: amount of glycol substance ($\text{C}_3\text{H}_7\text{CaO}_5\text{P}$) is not more than 1.5%.

$$\begin{aligned} &\text{Each mL of 0.01 mol/L sodium thiosulfate VS} \\ &= 0.4854 \text{ mg of } \text{C}_3\text{H}_7\text{CaO}_5\text{P} \end{aligned}$$

Water <2.48> Not more than 12.0% (0.1 g, volumetric titration, direct titration. Use a mixture of formamide for water determination and methanol for water determination (2:1) instead of methanol for water determination).

Assay Perform the test according to the Cylinder-plate method as directed under Microbial Assay for Antibiotics <4.02> according to the following conditions.

(i) Test organism—*Proteus* sp. (MB838)

(ii) Culture medium—Dissolve 5.0 g of peptone, 3.0 g of meat extract, 2.0 g of yeast extract, and 15 g of agar in 1000 mL of water, sterilize, and use as the agar media for base layer and seed layer with the pH of between 6.5 and 6.6 after sterilization.

(iii) Seeded agar layer—Incubate the test organism on the slant of the agar medium for transferring test organisms at 37°C for 40 – 48 hours. Subcultures at least 3 times. Inoculate the grown organisms onto the surface of 300 mL of the agar medium for transferring test organisms in a Roux bottle, incubate at 37°C for 40 – 48 hours, and suspend the grown organisms in about 30 mL of water. To the suspension add water, and use this as the stock suspension of test organism. The amount of the water to be added is adjust so that the percent transmission at 560 nm of the suspension diluted ten times with water is 17%. Keep the stock suspension at 10°C or below and use within 7 days. Add 1.0 – 2.0 mL of the stock suspension of test organism to 100 mL of the agar medium for seed layer previously kept at 48°C , mix thoroughly, and use this as the seeded agar layer.

(iv) Standard solutions—Weigh accurately an amount of Fosfomycin Phenethylammonium RS equivalent to about 20 mg (potency), dissolve in 0.05 mol/L tris buffer solution (pH 7.0) to make exactly 50 mL, and use this solution as the standard stock solution. Keep the standard stock solution at 5°C or below and use within 7 days. Take exactly a suitable amount of the standard stock solution before use, add 0.05 mol/L tris buffer solution (pH 7.0) to make solutions so that each mL contains 10 μg (potency) and 5 μg (potency), and use these solutions as the high concentration standard solution and the low concentration standard solution, respectively.

(v) Sample solutions—Weigh accurately an amount of Fosfomycin Calcium Hydrate equivalent to about 20 mg (potency), and dissolve in 0.05 mol/L tris buffer solution (pH 7.0) to make exactly 50 mL. To exactly a suitable amount of this solution add 0.05 mol/L tris buffer solution (pH 7.0) to make solutions so that each mL contains 10 μg (potency) and 5 μg (potency), and use these solutions as the high concentration sample solution and the low concentration sample solution, respectively.

Containers and storage Containers—Tight containers.

Fosfomycin Calcium for Syrup

シロップ用ホスホマイシンカルシウム

Fosfomycin Calcium for Syrup is a preparation for syrups which is suspended before use.

It contains not less than 90.0% and not more than 110.0% of the labeled potency of fosfomycin ($C_3H_7O_4P$: 138.06).

Method of preparation Prepare as directed under Syrups, with Fosfomycin Calcium Hydrate.

Identification (1) To an amount of Fosfomycin Calcium for Syrup, equivalent to 40 mg (potency) of Fosfomycin Calcium Hydrate, add 10 mL of warm water, shake for 10 to 20 minutes, and collect the insoluble substances by filtration. Dissolve the substances in 3 mL of a solution of perchloric acid (1 in 4), add 1 mL of 0.1 mol/L sodium periodate solution, and warm in a water bath at 60°C for 30 minutes. After cooling, add 50 mL of water, neutralize the solution with a saturated solution of sodium hydrogen carbonate, and add 1 mL of potassium iodide TS: the solution does not show a red color.

(2) To an amount of Fosfomycin Calcium for Syrup, equivalent to 40 mg (potency) of Fosfomycin Calcium Hydrate, add 10 mL of warm water, shake for 10 to 20 minutes, and collect the insoluble substances by filtration. Dissolve the substances in 3 mL of a solution of perchloric acid (1 in 4), add 2 mL of 0.1 mol/L sodium periodate solution, and heat in a water bath for 10 minutes. After cooling, add 1 mL of hexaammonium heptamolybdate-sulfuric acid TS and 1 mL of 1-amino-2-naphthol-4-sulfonic acid TS, and allow to stand for 30 minutes: the solution shows a blue color.

(3) To an amount of Fosfomycin Calcium for Syrup, equivalent to 40 mg (potency) of Fosfomycin Calcium Hydrate, add 10 mL of warm water, shake for 10 to 20 minutes, and collect the insoluble substances by filtration. Dissolve the substances in 25 mL of water: the solution responds to Qualitative Tests <1.09> (3) for calcium salt.

Loss on drying <2.41> Not more than 3.0% (2 g, reduced pressure not exceeding 0.67 kPa, 60°C, 3 hours).

Uniformity of dosage units <6.02> Fosfomycin Calcium for Syrup in single-dose packages meets the requirement of the Mass variation test.

Dissolution <6.10> When the test is performed at 50 revolutions per minute according to the Paddle method, using 900 mL of water as the dissolution medium, the dissolution rate in 15 minutes of Fosfomycin Calcium for Syrup is not less than 80%.

Start the test with an accurately weighed amount of Fosfomycin Calcium for Syrup, equivalent to about 0.5 g (potency) of Fosfomycin Calcium Hydrate, withdraw not less than 20 mL of the medium at the specified minute after starting the test, and filter through a membrane filter with a pore size not exceeding 0.45 μ m. Discard not less than 10 mL of the first filtrate, and use the subsequent filtrate as the sample solution. Separately, weigh accurately an amount of Fosfomycin Phenethylammonium RS, equivalent to about 28 mg (potency), dissolve in water to make exactly 50 mL, and use this solution as the standard solution. Perform the test with exactly 10 μ L each of the sample solution and standard solution as directed under Liquid Chromatography <2.01> according to the following conditions, and determine the peak areas, A_T and A_S , of fosfomycin in each solution.

Dissolution rate (%) with respect to the labeled amount of fosfomycin ($C_3H_7O_4P$)

$$= M_S/M_T \times A_T/A_S \times 1/C \times 1800$$

M_S : Amount [mg (potency)] of Fosfomycin Phenethylammonium RS taken

M_T : Amount (g) of Fosfomycin Calcium for Syrup taken
 C : Labeled amount [mg (potency)] of fosfomycin ($C_3H_7O_4P$) in 1 g

Operating conditions—

Detector: A conductivity detector.

Column: A polyetheretherketone column 4.6 mm in inside diameter and 7.5 cm in length, packed with quaternary ammonium group introducing hydrophilic vinyl polymer gel for liquid chromatography (6 μ m in particle diameter).

Column temperature: A constant temperature of about 30°C.

Mobile phase: Dissolve 10.5 g of citric acid monohydrate in water to make 1000 mL. To 800 mL of this solution add 200 mL of acetonitrile.

Flow rate: Adjust so that the retention time of fosfomycin is about 8 minutes.

System suitability—

System performance: When the procedure is run with 10 μ L of the standard solution under the above operating conditions, the number of theoretical plates and the symmetry factor of the peak of fosfomycin are not less than 2000 and not more than 2.0, respectively.

System repeatability: When the test is repeated 6 times with 10 μ L of the standard solution under the above operating conditions, the relative standard deviation of the peak area of fosfomycin is not more than 2.0%.

Assay Perform the test according to the Cylinder-plate method as directed under Microbial Assay for Antibiotics <4.02> according to the following conditions.

(i) Test organism, culture medium, agar media for seed and base layer, and standard solutions—Proceed as directed in the Assay under Fosfomycin Calcium Hydrate.

(ii) Sample solutions—Weigh accurately an amount of Fosfomycin Calcium for Syrup, equivalent to about 0.1 g (potency) of Fosfomycin Calcium Hydrate, dissolve in 0.05 mol/L tris buffer solution (pH 7.0) to make exactly 200 mL. Take exactly a suitable amount of this solution, add exactly 0.05 mol/L tris buffer solution (pH 7.0) to make solutions so that each mL contains 10 μ g (potency) and 5 μ g (potency), and use these solutions as the high concentration sample solution and the low concentration sample solution, respectively.

Containers and storage Containers—Tight containers.

Fosfomycin Sodium

ホスホマイシンナトリウム

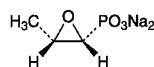

$C_3H_5Na_2O_4P$: 182.02
Sodium (2*R*,3*S*)-3-methyloxiran-2-ylphosphonate
[26016-99-9]

Fosfomycin Sodium is the sodium salt of a substance having antibacterial activity produced by the growth of *Streptomyces fradiae* or by the chemical synthesis.

It contains not less than 725 μg (potency) and not more than 770 μg (potency) per mg, calculated on the anhydrous basis. The potency of Fosfomycin Sodium is expressed as mass (potency) of fosfomycin ($C_3H_7O_4P$: 138.06).

Description Fosfomycin Sodium occurs as a white crystalline powder.

It is very soluble in water, sparingly soluble in methanol, and practically insoluble in ethanol (99.5).

Identification (1) Determine the infrared absorption spectrum of Fosfomycin Sodium as directed in the potassium bromide disk method under Infrared Spectrophotometry <2.25>, and compare the spectrum with the Reference Spectrum: both spectra exhibit similar intensities of absorption at the same wave numbers.

(2) Determine the ^1H spectrum of a solution of Fosfomycin Sodium in heavy water for nuclear magnetic resonance spectroscopy (1 in 300), using sodium 3-trimethylsilylpropanesulfonate for nuclear magnetic resonance spectroscopy as an internal reference compound, as directed under Nuclear Magnetic Resonance Spectroscopy <2.21>: it exhibits a double signal at around δ 1.5 ppm, a double double signal at around δ 2.8 ppm, a multiple signal at around δ 3.3 ppm, and no signal at around δ 1.3 ppm.

(3) A solution of Fosfomycin Sodium (1 in 500) responds to Qualitative Tests <1.09> (1) for sodium salt.

Optical rotation <2.49> $[\alpha]_D^{20}$: $-3.5 - -5.5^\circ$ (0.5 g calculated on the anhydrous bases, water, 10 mL, 100 mm).

pH <2.54> Dissolve 0.70 g of Fosfomycin Sodium in 10 mL of water: the pH of the solution is between 8.5 and 10.5.

Phosphorus Content Weigh accurately about 0.1 g of Fosfomycin Sodium, add 40 mL of a solution of sodium periodate (107 in 10,000) and 2 mL of perchloric acid, and heat in a water bath for 1 hour. After cooling, add water to make exactly 200 mL. Pipet 10 mL of this solution, and add 1 mL of potassium iodide TS. To this solution add sodium thiosulfate TS until the solution is colorless, add water to make exactly 100 mL, and use this solution as the sample stock solution. Separately, weigh accurately about 70 mg of potassium dihydrogen phosphate, proceed with this solution in the same manner as directed for the preparation of the sample stock solution, and use the solution so obtained as the standard stock solution. Proceed and prepare a solution in the same manner for the preparation of the sample stock solution without using Fosfomycin Sodium, and use the solution so obtained as the blank stock solution. Pipet 5 mL each of the sample stock solution, the standard stock solution, and the blank stock solution, add 2.5 mL of ammonium molyb-

date-sulfuric acid TS and 1 mL of 1-amino-2-naphthol-4-sulfonic acid TS, mix, and add water to make exactly 25 mL, and use these solutions as the sample solution, the standard solution, and the blank solution, respectively. After allowing these solutions to stand for 30 minutes at $20 \pm 1^\circ\text{C}$, perform the test with these solutions as directed under Ultraviolet-visible Spectrophotometry <2.24>, using water as a blank, and determine the absorbances at 740 nm, A_T , A_S and A_B , of the sample solution, the standard solution and the blank solution: the content of phosphorus is 16.2 – 17.9%.

$$\begin{aligned} &\text{Amount (mg) of phosphorus (P)} \\ &= M \times (A_T - A_B) / (A_S - A_B) \times 0.228 \end{aligned}$$

M : Amount (mg) of potassium dihydrogen phosphate taken

Purity (1) Clarity and color of solution—Dissolve 1.0 g of Fosfomycin Sodium in 10 mL of water: the solution is clear and colorless.

(2) Heavy metals <1.07>—Proceed with 1.0 g of Fosfomycin Sodium according to Method 1, and perform the test. Prepare the control solution with 2.0 mL Standard Lead Solution (not more than 20 ppm).

(3) Arsenic <1.11>—Prepare the test solution with 1.0 g of Fosfomycin Sodium according to Method 3, and perform the test (not more than 2 ppm).

(4) Glycol substance—Weigh accurately about 0.2 g of Fosfomycin Sodium, and dissolve in 100 mL of water in a 250-mL iodine flask. Add exactly 50 mL of phthalate buffer solution (pH 5.8) and exactly 5 mL of sodium periodate solution (107 in 100,000), stopper, stir, and add 1 mL of water in the receiving part. Allow to stand in a dark place for 90 minutes, add exactly 10 mL of a solution of potassium iodide (2 in 5) without haste, and titrate <2.50> with 0.01 mol/L sodium thiosulfate VS (indicator: 2 mL of starch TS). Perform a blank determination in the same manner, and make any necessary correction: amount of glycol substance ($C_3H_7Na_2O_5P$) is not more than 0.5%.

$$\begin{aligned} &\text{Each mL of 0.01 mol/L sodium thiosulfate VS} \\ &= 0.5001 \text{ mg of } C_3H_7Na_2O_5P \end{aligned}$$

Water <2.48> Not more than 3.0% (0.2 g, volumetric titration, direct titration).

Assay Perform the test according to the Cylinder-plate method as directed under Microbial Assay for Antibiotics <4.02> according to the following conditions.

(i) Test organism—*Proteus* sp. (MB838)

(ii) Culture medium—Mix 5.0 g of peptone, 3.0 g of meat extract, 2.0 g of yeast extract, and 15 g of agar in 1000 mL of water, sterilize, and use as the agar media for base layer and seed layer with the pH of between 6.5 and 6.6 after sterilization.

(iii) Seeded agar layer—Incubate the test organism on the slant of the agar medium for transferring test organisms at 37°C for 40–48 hours. Subcultures at least 3 times. Inoculate the grown organisms onto the surface of 300 mL of the agar medium for transferring test organisms in a Roux bottle, incubate at 37°C for 40–48 hours, and suspend the grown organisms in about 30 mL of water. To the suspension add water, and use this as the stock suspension of test organism. The amount of the water to be added is adjust so that the percent transmission at 560 nm of the suspension diluted ten times with water is 17%. Keep the stock suspension at 10°C or below and use within 7 days. Add 1.0–2.0 mL of the stock suspension of test organism to 100 mL of the agar medium for seed layer previously kept at 48°C , mix thoroughly, and use this as the seeded agar layer.

(iv) Standard solutions—Weigh accurately an amount of Fosfomycin Phenethylammonium RS equivalent to about 20 mg (potency), dissolve in 0.05 mol/L tris buffer solution (pH 7.0) to make exactly 50 mL, and use this solution as the standard stock solution. Keep the standard stock solution at 5°C or below and use within 7 days. Take exactly a suitable amount of the standard stock solution before use, add 0.05 mol/L tris buffer solution (pH 7.0) to make solutions so that each mL contains 10 µg (potency) and 5 µg (potency), and use these solutions as the high concentration standard solution and the low concentration standard solution, respectively.

(v) Sample solutions—Weigh accurately an amount of Fosfomycin Sodium equivalent to about 20 mg (potency), and dissolve in 0.05 mol/L tris buffer solution (pH 7.0) to make exactly 50 mL. To exactly a suitable amount of this solution add 0.05 mol/L tris buffer solution (pH 7.0) to make solutions so that each mL contains 10 µg (potency) and 5 µg (potency), and use these solutions as the high concentration sample solution and the low concentration sample solution, respectively.

Containers and storage Containers—Hermetic containers.

Fosfomycin Sodium for Injection

注射用ホスホマイシシナトリウム

Fosfomycin Sodium for Injection is a preparation for injection which is dissolved before use.

It contains not less than 90.0% and not more than 110.0% of the labeled potency of fosfomycin (C₃H₇O₄P: 138.06).

Method of preparation Prepare as directed under Injections, with Fosfomycin Sodium.

Description Fosfomycin Sodium for Injection occurs as a white crystalline powder.

Identification (1) Dissolve about 0.1 g of Fosfomycin Sodium for Injection in 3 mL of a solution of perchloric acid (1 in 4), add 1 mL of 0.1 mol/L sodium periodate solution, and heat in a water bath at 60°C for 30 minutes. After cooling, add 50 mL of water, neutralize with saturated sodium hydrogen carbonate solution, and add 1 mL of potassium iodide TS; the solution does not reveal a red color, while the blank solution reveals a red color.

(2) To 2 mL of a solution of Fosfomycin Sodium for Injection (1 in 250) add 1 mL of perchloric acid and 2 mL of 0.1 mol/L sodium periodate solution, and heat in a water bath for 10 minutes. After cooling, add 1 mL of hexaammonium heptamolybdate-sulfuric acid TS and 1 mL of 1-amino-2-naphthol-4-sulfonic acid TS, and allow to stand for 30 minutes: a blue color develops.

(3) Dissolve an amount of Fosfomycin Sodium for Injection, equivalent to 0.1 g (potency) of Fosfomycin Sodium, in 50 mL of water. Perform the test with this solution as directed in the Identification (3) under Fosfomycin Sodium.

pH <2.54> The pH of a solution prepared by dissolving an amount of Fosfomycin Sodium for Injection, equivalent to 1.0 g (potency) of Fosfomycin Sodium, in 20 mL of water is between 6.5 and 8.5.

Purity Clarity and color of solution—Dissolve an amount of Fosfomycin Sodium for Injection, equivalent to 1.0 g (potency) of Fosfomycin Sodium, in 10 mL of water: the so-

lution is clear and colorless.

Water <2.48> Not more than 4.0% (0.1 g, coulometric titration).

Bacterial endotoxins <4.01> Less than 0.025 EU/mg (potency).

Uniformity of dosage units <6.02> It meets the requirement of the Mass variation test.

Foreign insoluble matter <6.06> Perform the test according to the Method 2: it meets the requirement.

Insoluble particulate matter <6.07> It meets the requirement.

Sterility <4.06> Perform the test according to the Membrane filtration method: it meets the requirement.

Assay Perform the test according to the Cylinder-plate method as directed under Microbial Assay for Antibiotics <4.02> according to the following conditions.

(i) Test organism, culture medium, seeded agar layer, and standard solutions—Proceed as directed in the Assay under Fosfomycin Sodium.

(ii) Sample solutions—Weigh accurately the mass of the contents of not less than 10 Fosfomycin Sodium for Injection. Weigh accurately an amount of the content, equivalent to about 20 mg (potency) of Fosfomycin Sodium, and dissolve in 0.05 mol/L tris buffer solution (pH 7.0) to make exactly 50 mL. Take exactly a suitable amount of this solution, add 0.05 mol/L tris buffer solution (pH 7.0) to make solutions so that each mL contains 10 µg (potency) and 5 µg (potency), and use these solutions as the high concentration sample solution and the low concentration sample solution, respectively.

Containers and storage Containers—Hermetic containers. Plastic containers for aqueous injections may be used.

Fradiomycin Sulfate

Neomycin Sulfate

フラジオマイシン硫酸塩

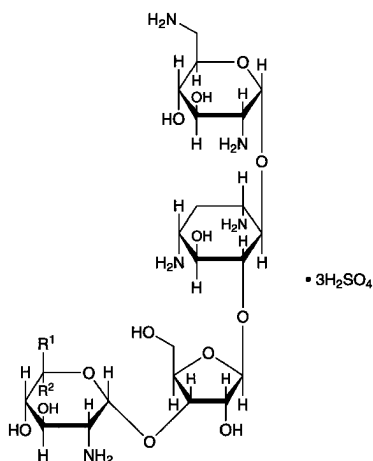

Fradiomycin B Sulfate : $\text{R}^1=\text{H}$ $\text{R}^2=\text{CH}_2\text{NH}_2$

Fradiomycin C Sulfate : $\text{R}^1=\text{CH}_2\text{NH}_2$ $\text{R}^2=\text{H}$

$\text{C}_{23}\text{H}_{46}\text{N}_6\text{O}_{13} \cdot 3\text{H}_2\text{SO}_4$: 908.88

Fradiomycin B Sulfate

2,6-Diamino-2,6-dideoxy- α -D-glucopyranosyl-(1 \rightarrow 4)-
[2,6-diamino-2,6-dideoxy- β -L-idopyranosyl-(1 \rightarrow 3)- β -D-
ribofuranosyl-(1 \rightarrow 5)]-2-deoxy-D-streptamine trisulfate
[119-04-0, Neomycin B]

Fradiomycin C Sulfate

2,6-Diamino-2,6-dideoxy- α -D-glucopyranosyl-(1 \rightarrow 4)-
[2,6-diamino-2,6-dideoxy- α -D-glucopyranosyl-(1 \rightarrow 3)-
 β -D-ribofuranosyl-(1 \rightarrow 5)]-2-deoxy-D-streptamine trisulfate
[66-86-4, Neomycin C]
[1405-10-3, Neomycin Sulfate]

Fradiomycin Sulfate is the sulfate of a mixture of aminoglycoside substances having antibacterial activity produced by the growth of *Streptomyces fradiae*.

It, when dried, contains not less than 623 μg (potency) and not more than 740 μg (potency) per mg. The potency of Fradiomycin Sulfate is expressed as mass (potency) of fradiomycin ($\text{C}_{23}\text{H}_{46}\text{N}_6\text{O}_{13}$: 614.64).

Description Fradiomycin Sulfate occurs as a white to light yellow powder.

It is freely soluble in water, and practically insoluble in ethanol (95).

It is hygroscopic.

Identification (1) Dissolve 50 mg each of Fradiomycin Sulfate and Fradiomycin Sulfate RS in 1 mL of water, and use these solutions as the sample solution and the standard solution. Perform the test with these solutions as directed under Thin-layer Chromatography <2.03>. Spot 2 μL each of the sample solution and standard solution on a plate of silica gel for thin-layer chromatography. Develop the plate with a mixture of methanol, ammonia solution (28) and dichloromethane (3:2:1) to a distance of about 10 cm, and air-dry the plate. Spray evenly a solution of ninhydrin in acetone (1 in 50) on the plate, and heat at 110°C for 15 minutes: the principal spot obtained from the sample solution and the spot from the standard solution show the same R_f value.

(2) A solution of Fradiomycin Sulfate (1 in 20) responds to Qualitative Tests <1.09> (1) for sulfate.

Optical rotation <2.49> $[\alpha]_{\text{D}}^{20}$: +53.5 – +59.0° (1 g calculated on the dried basis, water, 10 mL, 100 mm).

pH <2.54> The pH of a solution obtained by dissolving 1.0 g of Fradiomycin Sulfate in 10 mL of water is between 5.0 and 7.5.

Purity (1) Heavy metals <1.07>—Proceed with 1.0 g of Fradiomycin Sulfate according to Method 2, and perform the test. Prepare the control solution with 2.0 mL of Standard Lead Solution (not more than 20 ppm).

(2) Arsenic <1.11>—Prepare the test solution with 1.0 g of Fradiomycin Sulfate according to Method 1, and perform the test (not more than 2 ppm).

(3) Related substances—Dissolve 0.63 g of Fradiomycin Sulfate in 5 mL of water, and use this solution as the sample solution. Pipet 1 mL of the sample solution, add water to make exactly 50 mL, and use this solution as the standard solution. Perform the test with these solutions as directed under Thin-layer Chromatography <2.03>. Spot 1 μL each of the sample solution and standard solution on a plate of silica gel for thin-layer chromatography. Develop the plate with a mixture of methanol, ammonia solution (28) and dichloromethane (3:2:1) to a distance of about 10 cm, and air-dry the plate. Spray evenly a solution of ninhydrin in acetone (1 in 50) on the plate, and heat the plate at 110°C for 15 minutes: the spot at around R_f value 0.4 obtained from the sample solution is not more intense than the spot from the standard solution.

Loss on drying <2.41> Not more than 8.0% (0.2 g, in vacuum, 60°C, 3 hours).

Residue on ignition <2.44> Not more than 0.3% (1 g).

Assay Perform the test according to the Cylinder-plate method as directed under Microbial Assay for Antibiotics <4.02> according to the following conditions.

- (i) Test organism—*Staphylococcus aureus* ATCC 6538 P
(ii) Agar medium for seed and base layer

Glucose	1.0 g
Peptone	6.0 g
Meat extract	1.5 g
Yeast extract	3.0 g
Sodium chloride	2.5 g
Agar	15.0 g
Water	1000 mL

Mix all the ingredients and sterilize. Adjust the pH after sterilization to 7.8 – 8.0 with sodium hydroxide TS.

(iii) Standard solutions—Weigh accurately an amount of Fradiomycin Sulfate RS, previously dried, equivalent to about 50 mg (potency), dissolve in 0.1 mol/L phosphate buffer solution for antibiotics (pH 8.0) to make exactly 50 mL, and use this solution as the standard stock solution. Keep the standard stock solution at 5°C or below and use within 14 days. Take exactly a suitable amount of the standard stock solution before use, add 0.1 mol/L phosphate buffer solution for antibiotics (pH 8.0) to make solutions so that each mL contains 80 μg (potency) and 20 μg (potency), and use these solutions as the high concentration standard solution and the low concentration standard solution, respectively.

(iv) Sample solutions—Weigh accurately an amount of Fradiomycin Sulfate, previously dried, equivalent to about 50 mg (potency), dissolve in 0.1 mol/L phosphate buffer solution for antibiotics (pH 8.0) to make exactly 50 mL. Take exactly a suitable amount of this solution, add 0.1 mol/L

phosphate buffer solution for antibiotics (pH 8.0) to make solutions so that each mL contains 80 μg (potency) and 20 μg (potency), and use these solutions as the high concentration sample solution and the low concentration sample solution, respectively.

Containers and storage Containers—Tight containers.
Storage—Light-resistant.

Fructose

果糖

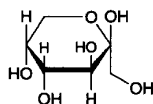

$\text{C}_6\text{H}_{12}\text{O}_6$; 180.16
 β -D-Fructopyranose
[57-48-7]

Fructose, when dried, contains not less than 98.0% of fructose ($\text{C}_6\text{H}_{12}\text{O}_6$).

Description Fructose occurs as colorless to white, crystals or crystalline powder. It is odorless and has a sweet taste.

It is very soluble in water, sparingly soluble in ethanol (95) and practically insoluble in diethyl ether.

It is hygroscopic.

Identification (1) Add 2 to 3 drops of a solution of Fructose (1 in 20) to 5 mL of boiling Fehling's TS: a red precipitate is produced.

(2) Determine the infrared absorption spectrum of Fructose as directed in the paste method under Infrared Spectrophotometry <2.25>, and compare the spectrum with the Reference Spectrum: both spectra exhibit similar intensities of absorption at the same wave numbers.

pH <2.54> Dissolve 4.0 g of Fructose in 20 mL of water: the pH of the solution is between 4.0 and 6.5.

Purity (1) Clarity and color of solution—Dissolve 25.0 g of Fructose in 50 mL of water: the solution is clear and has no more color than the following control solution.

Control solution: To a mixture of 1.0 mL of Cobalt (II) Chloride CS, 3.0 mL of Iron (III) Chloride CS and 2.0 mL of Copper (II) Sulfate CS, and add water to make 10.0 mL. To 3.0 mL of the solution add water to make 50 mL.

(2) Acidity—Dissolve 5.0 g of Fructose in 50 mL of freshly boiled and cooled water, and add 3 drops of phenolphthalein TS and 0.60 mL of 0.01 mol/L sodium hydroxide VS: a red color develops.

(3) Chloride <1.03>—Perform the test with 2.0 g of Fructose. Prepare the control solution with 1.0 mL of 0.01 mol/L hydrochloric acid VS (not more than 0.018%).

(4) Sulfate <1.14>—Perform the test with 2.0 g of Fructose. Prepare the control solution with 1.0 mL of 0.005 mol/L sulfuric acid VS (not more than 0.024%).

(5) Sulfite—Dissolve 0.5 g of Fructose in 5 mL of water, and add 0.25 mL of 0.02 mol/L iodine: the color of the solution is yellow.

(6) Heavy metals <1.07>—Proceed with 5.0 g of Fructose according to Method 2, and perform the test. Prepare the control solution with 2.0 mL of Standard Lead Solution (not more than 4 ppm).

(7) Calcium—Dissolve 0.5 g of Fructose in 5 mL of water, add 2 to 3 drops of ammonia TS and 1 mL of ammonium oxalate TS, and allow to stand for 1 minute: the solu-

tion is clear.

(8) Arsenic <1.11>—Dissolve 1.5 g of Fructose in 5 mL of water, heat with 5 mL of dilute sulfuric acid and 1 mL of bromine TS on a water bath for 5 minutes, concentrate to 5 mL, and cool. Perform the test with this solution as the test solution (not more than 1.3 ppm).

(9) 5-Hydroxymethylfurfurals—Dissolve 5.0 g of Fructose in 100 mL of water, and read the absorbance at 284 nm as directed under Ultraviolet-visible Spectrophotometry <2.24>: the absorbance is not more than 0.32.

Loss on drying <2.41> Not more than 0.5% (1 g, in vacuum, silica gel, 3 hours).

Residue on ignition <2.44> Not more than 0.1% (1 g).

Assay Weigh accurately about 4 g of Fructose, previously dried, dissolve in 0.2 mL of ammonia TS and 80 mL of water, and after standing for 30 minutes add water to make exactly 100 mL, and determine the optical rotation, α_D , in a 100-mm cell at $20 \pm 1^\circ\text{C}$ as directed under Optical Rotation Determination <2.49>.

Amount (mg) of fructose ($\text{C}_6\text{H}_{12}\text{O}_6$) = $|\alpha_D| \times 1087.0$

Containers and storage Containers—Tight containers.

Fructose Injection

果糖注射液

Fructose Injection is an aqueous injection.

It contains not less than 95.0% and not more than 105.0% of the labeled amount of fructose ($\text{C}_6\text{H}_{12}\text{O}_6$; 180.16).

Method of preparation Prepare as directed under Injections, with Fructose. No preservative is added.

Description Fructose Injection is a colorless to pale yellow, clear liquid. It has a sweet taste.

Identification (1) Take a volume of Fructose Injection, equivalent to 1 g of Fructose, dilute with water or concentrate on a water bath to 20 mL, if necessary, and use this solution as the sample solution. Add 2 to 3 drops of the sample solution to 5 mL of boiling Fehling's TS: a red precipitate is produced.

(2) To 10 mL of the sample solution obtained in (1) add 0.1 g of resorcinol and 1 mL of hydrochloric acid, and warm in a water bath for 3 minutes: a red color develops.

pH <2.54> 3.0 – 6.5 In the case where the labeled concentration of the injection exceeds 5%, dilute to 5% with water before the test.

Purity (1) Heavy metals <1.07>—Take a volume of Fructose Injection, equivalent to 5.0 g of Fructose, and evaporate on a water bath to dryness. With the residue, proceed according to Method 2, and perform the test. Prepare the control solution with 2.0 mL of Standard Lead Solution.

(2) Arsenic <1.11>—Take a volume of Fructose Injection, equivalent to 1.5 g of Fructose, dilute with water or concentrate on a water bath to 5 mL, if necessary, and add 5 mL of dilute sulfuric acid and 1 mL of bromine TS. Proceed as directed in the purity (8) under Fructose.

Residue on ignition <2.44> Measure exactly a volume of Fructose Injection, equivalent to 2 g of Fructose, evaporate on a water bath to dryness, and perform the test: the residue weighs not more than 2 mg.

Bacterial endotoxins <4.01> Less than 0.5 EU/mL.

Extractable volume <6.05> It meets the requirement.

Foreign insoluble matter <6.06> Perform the test according to Method 1: it meets the requirement.

Insoluble particulate matter <6.07> It meets the requirement.

Sterility <4.06> Perform the test according to the Membrane filtration method: it meets the requirement.

Assay Measure exactly a volume of Fructose Injection, equivalent to about 4 g of fructose (C₆H₁₂O₆), add 0.2 mL of ammonia TS, dilute with water to make exactly 100 mL, shake well, and after allowing to stand for 30 minutes, determine the optical rotation, α_D , in a 100-mm cell at 20 ± 1°C as directed under Optical Rotation Determination <2.49>.

Amount (mg) of fructose (C₆H₁₂O₆) = $|\alpha_D| \times 1087.0$

Containers and storage Containers—Hermetic containers. Plastic containers for aqueous injections may be used.

Fudosteine

フドステイン

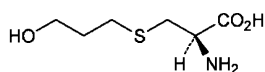

C₆H₁₃NO₃S: 179.24

(2*R*)-2-Amino-3-(3-hydroxypropylsulfanyl)propanoic acid
[13189-98-5]

Fudosteine, when dried, contains not less than 99.0% and not more than 101.0% of fudosteine (C₆H₁₃NO₃S).

Description Fudosteine occurs as white, crystals or crystalline powder.

It is freely soluble in water, slightly soluble in acetic acid (100), and practically insoluble in ethanol (99.5).

It dissolves in 6 mol/L hydrochloric acid TS.

Melting point: about 200°C (with decomposition).

Identification (1) To 5 mL of a solution of fudosteine (1 in 1000) add 2 mL of sodium hydroxide TS, shake well, add 0.3 mL of sodium pentacyanonitrosylferrate (III) TS, and shake well again. After allowing to stand at 40°C for 10 minutes, cool the solution in an ice bath for 2 minutes, add 2 mL of dilute hydrochloric acid, and shake: a red-orange color develops.

(2) Determine the infrared absorption spectrum of Fudosteine as directed in the potassium bromide disk method under Infrared Spectrophotometry <2.25>, and compare the spectrum with the Reference Spectrum: both spectra exhibit similar intensities of absorption at the same wave numbers.

Optical rotation <2.49> $[\alpha]_D^{20}$: -7.4 - -8.9° (after drying, 1 g, 6 mol/L hydrochloric acid TS, 25 mL, 100 mm).

Purity (1) Chloride <1.03>—Dissolve 0.20 g of Fudosteine in 10 mL of water and 20 mL of nitric acid, and add water to make 50 mL. Perform the test using this solution as the test solution. Prepare the control solution as follows: to 0.25 mL of 0.01 mol/L hydrochloric acid VS add 20 mL of nitric acid and water to make 50 mL (not more than 0.044%).

(2) Heavy metals <1.07>—Proceed with 2.0 g of Fudoste-

ine according to Method 2, and perform the test. Prepare the control solution with 2.0 mL of Standard Lead solution (not more than 10 ppm).

(3) Arsenic <1.11>—Prepare the test solution with 2.0 g of Fudosteine according to Method 3, and perform the test (not more than 1 ppm).

(4) L-Cystine—Dissolve exactly 0.25 g of Fudosteine in the mobile phase to make exactly 50 mL, and use this solution as the sample solution. Separately, dissolve exactly 25 mg of L-cystine in 2 mL of 1 mol/L hydrochloric acid TS, then add the mobile phase to make exactly 50 mL. Pipet 2.5 mL of this solution, add the mobile phase to make exactly 50 mL, and use this solution as the standard solution. Perform the test with exactly 10 μ L each of the sample solution and standard solution as directed under Liquid Chromatography <2.01> according to the following conditions. Determine each peak area by the automatic integration method: the peak area of L-cystine obtained from the sample solution is not larger than the peak area of L-cystine from the standard solution.

Operating conditions—

Detector: An ultraviolet absorption photometer (wavelength: 210 nm).

Column: A stainless steel column 4.6 mm in inside diameter and 15 cm in length, packed with octadecylsilanized silica gel for liquid chromatography (5 μ m in particle diameter).

Column temperature: A constant temperature of about 50°C.

Mobile phase: A solution of sodium 1-hexanesulfonate in diluted phosphoric acid (1 in 1000) (1 in 1250).

Flow rate: Adjust so that the retention time of fudosteine is about 8 minutes.

System suitability—

System performance: Dissolve 25 mg of L-cystine in 2 mL of 1 mol/L hydrochloric acid TS, add 25 mg of Fudosteine, and add the mobile phase to make 50 mL. Take 2.5 mL of this solution, add the mobile phase to make 50 mL. When the procedure is run with 10 μ L of this solution under the above operating conditions, L-cystine and fudosteine are eluted in this order with the resolution between these peaks being not less than 10.

System repeatability: When the test is repeated 6 times with 10 μ L of the standard solution under the above operating conditions, the relative standard deviation of the peak area of L-cystine is not more than 2.0%.

(5) Related substances—Dissolve 0.25 g of Fudosteine in the mobile phase to make 50 mL, and use this solution as the sample solution. Pipet 2 mL of the sample solution, add the mobile phase to make exactly 100 mL, pipet 2.5 mL of this solution, add the mobile phase to make exactly 50 mL, and use this solution as the standard solution. Perform the test with exactly 10 μ L each of the sample solution and standard solution as directed under Liquid Chromatography <2.01> according to the following conditions. Determine each peak area by the automatic integration method: the area of the peak other than fudosteine obtained from the sample solution is not larger than the peak area of fudosteine from the standard solution.

Operating conditions—

Detector: An ultraviolet absorption photometer (wavelength: 210 nm).

Column: A stainless steel column 4.6 mm in inside diameter and 25 cm in length, packed with octadecylsilanized silica gel for liquid chromatography (5 μ m in particle diameter).

Column temperature: A constant temperature of about 55°C.

Mobile phase: Diluted phosphoric acid (1 in 1000).

Flow rate: Adjust so that the retention time of fudosteine is about 3 minutes.

Time span of measurement: About 10 times as long as the retention time of fudosteine, beginning after the peak of fudosteine.

System suitability—

System performance: When the procedure is run with 10 μ L of the standard solution under the above operating conditions, the number of theoretical plates and the symmetry factor of the peak of fudosteine are not less than 5000 and not more than 1.5, respectively.

System repeatability: When the test is repeated 6 times with 10 μ L of the standard solution under the above operating conditions, the relative standard deviation of the peak area of fudosteine is not more than 2.0%.

Loss on drying <2.41>—Not more than 0.5% (1 g, 105°C, 3 hours).

Residue on ignition <2.44>—Not more than 0.1% (1 g).

Assay Weigh accurately about 0.3 g of Fudosteine, previously dried, dissolve in 50 mL of acetic acid (100), and titrate <2.50> with 0.1 mol/L perchloric acid VS (potentiometric titration). Perform a blank determination in the same manner, and make any necessary correction.

Each mL of 0.1 mol/L perchloric acid VS
= 17.92 mg of C₆H₁₃NO₃S

Containers and storage Containers—Well-closed containers.

Fudosteine Tablets

フドステイン錠

Fudosteine Tablets contain not less than 95.0% and not more than 105.0% of the labeled amount of fudosteine (C₆H₁₃NO₃S; 179.24).

Method of preparation Prepare as directed under Tablets, with Fudosteine.

Identification Powder Fudosteine Tablets. To a portion of the powder, equivalent to 88 mg of Fudosteine, add 10 mL of a mixture of water and methanol (1:1), shake, centrifuge, and use the supernatant liquid as the sample solution. Separately, dissolve 90 mg of fudosteine for assay in 10 mL of a mixture of water and methanol (1:1), and use this solution as the standard solution. Perform the test with these solutions as directed under Thin-layer Chromatography <2.03>. Spot 2.5 μ L each of the sample solution and standard solution on a plate of silica gel for thin-layer chromatography. Develop the plate with a mixture of 1-butanol, water and acetic acid (100) (3:2:1) to a distance of about 10 cm, and air-dry the plate. Spray evenly a solution of ninhydrin in acetone (1 in 50) on the plate, and heat at 80°C for 5 minutes: the principal spot obtained from the sample solution and the spot from the standard solution show a red-purple color and have the same *R_f* value.

Uniformity of dosage units <6.02> It meets the requirement of the Mass variation test.

Dissolution <6.10> When the test is performed at 75 revolutions per minute according to the Paddle method, using 900 mL of water as the dissolution medium, the dissolution rate in 20 minutes of Fudosteine Tablets is not less than 85%.

Start the test with 1 tablet of Fudosteine Tablets, with-

draw not less than 20 mL of the medium at the specified minute after starting the test, and filter through a membrane filter with a pore size not exceeding 0.45 μ m. Discard not less than 5 mL of the first filtrate, pipet *V* mL of the subsequent filtrate, add the mobile phase to make exactly *V'* mL so that each mL contains about 55.6 μ g of fudosteine (C₆H₁₃NO₃S), and use this solution as the sample solution. Separately, weigh accurately about 50 mg of fudosteine for assay, previously dried at 105°C for 3 hours, dissolve in the mobile phase to make exactly 50 mL. Pipet 5 mL of this solution, add the mobile phase to make exactly 100 mL, and use this solution as the standard solution. Perform the test with exactly 20 μ L each of the sample solution and standard solution as directed under Liquid Chromatography <2.01> according to the following conditions, and determine the peak areas, *A_T* and *A_S*, of fudosteine in each solution.

Dissolution rate (%) with respect to the labeled amount of fudosteine (C₆H₁₃NO₃S)
= $M_S \times A_T/A_S \times V'/V \times 1/C \times 90$

M_S: Amount (mg) of fudosteine for assay taken

C: Labeled amount (mg) of fudosteine (C₆H₁₃NO₃S) in 1 tablet

Operating conditions—

Proceed as directed in the operating conditions in the Assay.

System suitability—

System performance: When the procedure is run with 20 μ L of the standard solution under the above operating conditions, the number of theoretical plates and the symmetry factor of the peak of fudosteine are not less than 5000 and not more than 1.5, respectively.

System repeatability: When the test is repeated 6 times with 20 μ L of the standard solution under the above operating conditions, the relative standard deviation of the peak area of fudosteine is not more than 2.0%.

Assay Weigh accurately the mass of not less than 20 Fudosteine Tablets, and powder. Weigh accurately a portion of the powder, equivalent to about 0.5 g of fudosteine (C₆H₁₃NO₃S), add 70 mL of the mobile phase, shake vigorously for 15 minutes, add the mobile phase to make exactly 100 mL, and centrifuge. Pipet 10 mL of the supernatant liquid, and add the mobile phase to make exactly 50 mL. Pipet 5 mL of this solution, add exactly 5 mL of the internal standard solution, add the mobile phase to make 50 mL, and use this solution as the sample solution. Separately, weigh accurately about 50 mg of fudosteine for assay, previously dried at 105°C for 3 hours, and dissolve in the mobile phase to make exactly 50 mL. Pipet 5 mL of this solution, add exactly 5 mL of the internal standard solution, add the mobile phase to make 50 mL, and use this solution as the standard solution. Perform the test with 20 μ L each of the sample solution and standard solution as directed under Liquid Chromatography <2.01> according to the following conditions, and calculate the ratios, *Q_T* and *Q_S*, of the peak area of fudosteine to that of the internal standard.

Amount (mg) of fudosteine (C₆H₁₃NO₃S)
= $M_S \times Q_T/Q_S \times 10$

M_S: Amount (mg) of fudosteine for assay taken

Internal standard solution—A solution of L-methionine in the mobile phase (1 in 1000).

Operating conditions—

Detector: An ultraviolet absorption photometer (wavelength: 210 nm).

Column: A stainless steel column 4.6 mm in inside diameter and 15 cm in length, packed with octadecylsilanized silica gel for liquid chromatography (5 μ m in particle diameter).

Column temperature: A constant temperature of about 50°C.

Mobile phase: A solution of sodium 1-hexanesulfonate in diluted phosphoric acid (1 in 1000) (1 in 1250).

Flow rate: Adjust so that the retention time of furosteine is about 8 minutes.

System suitability—

System performance: When the procedure is run with 20 μ L of the standard solution under the above operating conditions, furosteine and the internal standard are eluted in this order with the resolution between these peaks being not less than 12.

System repeatability: When the test is repeated 6 times with 20 μ L of the standard solution under the above operating conditions, the relative standard deviation of the ratio of the peak area of furosteine to that of the internal standard is not more than 1.0%.

Containers and storage containers—Tight containers.

Furosemide

フロセミド

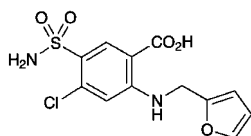

$C_{12}H_{11}ClN_2O_5S$: 330.74

4-Chloro-2-[(furan-2-ylmethyl)amino]-5-sulfamoylbenzoic acid

[54-31-9]

Furosemide, when dried, contains not less than 98.0% and not more than 101.0% of furosemide ($C_{12}H_{11}ClN_2O_5S$).

Description Furosemide occurs as white, crystals or crystalline powder.

It is freely soluble in *N,N*-dimethylformamide, soluble in methanol, sparingly soluble in ethanol (99.5), slightly soluble in acetonitrile and in acetic acid (100), and practically insoluble in water.

It dissolves in dilute sodium hydroxide TS.

It is gradually colored by light.

Melting point: about 205°C (with decomposition).

Identification (1) Dissolve 25 mg of Furosemide in 10 mL of methanol. To 1 mL of this solution add 10 mL of 2 mol/L hydrochloric acid TS. Heat the solution under a reflux condenser on a water bath for 15 minutes, cool, and add 18 mL of sodium hydroxide TS to make weakly acidic: the solution responds to Qualitative Tests <1.09> for primary aromatic amines, producing a red to red-purple color.

(2) Determine the absorption spectrum of a solution of Furosemide in dilute sodium hydroxide TS (1 in 125,000) as directed under Ultraviolet-visible Spectrophotometry <2.24>, and compare the spectrum with the Reference Spectrum or the spectrum of a solution of Furosemide RS prepared in the same manner as the sample solution: both spectra exhibit similar intensities of absorption at the same wavelengths.

(3) Determine the infrared absorption spectrum of Furosemide as directed in the potassium bromide disk

method under Infrared Spectrophotometry <2.25>, and compare the spectrum with the Reference Spectrum or the spectrum of Furosemide RS: both spectra exhibit similar intensities of absorption at the same wave numbers.

Purity (1) Clarity and color of solution—Dissolve 0.5 g of Furosemide in 10 mL of a solution of sodium hydroxide (1 in 50): the solution is clear and colorless.

(2) Chloride <1.03>—Dissolve 2.6 g of Furosemide in 90 mL of dilute sodium hydroxide TS, add 2 mL of nitric acid, and filter. To 25 mL of the filtrate add 6 mL of dilute nitric acid and water to make 50 mL, and perform the test using this solution as the test solution. Prepare the control solution as follows: To 0.40 mL of 0.01 mol/L hydrochloric acid VS add 6 mL of dilute nitric acid and water to make 50 mL (not more than 0.020%).

(3) Sulfate <1.14>—To 20 mL of the filtrate obtained in (2) add 1 mL of dilute hydrochloric acid and water to make 50 mL, and perform the test using this solution as the test solution. Prepare the control solution as follows: To 0.35 mL of 0.005 mol/L sulfuric acid VS add 1 mL of dilute hydrochloric acid and water to make 50 mL (not more than 0.030%).

(4) Heavy metals <1.07>—Proceed with 2.0 g of Furosemide according to Method 2, and perform the test. Prepare the control solution with 2.0 mL of Standard Lead Solution (not more than 10 ppm).

(5) Related substances—Dissolve 25 mg of Furosemide in 25 mL of the dissolving solution, and use this solution as the sample solution. Pipet 1 mL of the sample solution, add the dissolving solution to make exactly 200 mL, and use this solution as the standard solution. Perform the test with exactly 20 μ L each of the sample solution and standard solution as directed under Liquid Chromatography <2.01> according to the following conditions, and determine each peak area by the automatic integration method: the area of each peak appeared ahead of the peak of furosemide obtained from sample solution is not larger than 2/5 times the peak area of furosemide from the standard solution, the area of each peak appeared behind the peak of furosemide is not larger than 1/4 times the peak area of furosemide from the standard solution, and the total area of these peaks is not larger than 2 times the peak area of furosemide from the standard solution.

Dissolving solution—To 22 mL of acetic acid (100) add a mixture of water and acetonitrile (1:1) to make 1000 mL.

Operating conditions—

Detector: An ultraviolet absorption photometer (wavelength: 272 nm).

Column: A stainless steel column 4.6 mm in inside diameter and 25 cm in length, packed with octadecylsilanized silica gel for liquid chromatography (5 μ m in particle diameter).

Column temperature: A constant temperature of about 25°C.

Mobile phase: A mixture of water, tetrahydrofuran and acetic acid (100) (70:30:1).

Flow rate: Adjust so that the retention time of furosemide is about 18 minutes.

Time span of measurement: About 2.5 times as long as the retention time of furosemide, beginning after the solvent peak.

System suitability—

Test for required detectability: Measure exactly 2 mL of the standard solution, and add the dissolving solution to make exactly 50 mL. Confirm that the peak area of furosemide obtained with 20 μ L of this solution is equivalent to 3.2 to 4.8% of that with 20 μ L of the standard solution.

System performance: When the procedure is run with 20 μL of the standard solution under the above operating conditions, the number of theoretical plates and the symmetry factor of the peak of furosemide is not less than 7000 and not more than 1.5, respectively.

System repeatability: When the test is repeated 6 times with 20 μL of the standard solution under the above operating conditions, the relative standard deviation of the peak area of furosemide is not more than 2.0%.

Loss on drying <2.41> Not more than 0.5% (1 g, 105°C, 4 hours).

Residue on ignition <2.44> Not more than 0.1% (1 g).

Assay Weigh accurately about 0.5 g of Furosemide, previously dried, dissolve in 50 mL of *N,N*-dimethylformamide, and titrate <2.50> with 0.1 mol/L sodium hydroxide VS until the color of the solution changes from yellow to blue (indicator: 3 drops of bromothymol blue TS). Perform a blank determination with a mixture of 50 mL of *N,N*-dimethylformamide and 15 mL of water in the same manner, and make any necessary correction.

Each mL of 0.1 mol/L sodium hydroxide VS
= 33.07 mg of $\text{C}_{12}\text{H}_{11}\text{ClN}_2\text{O}_5\text{S}$

Containers and storage Containers—Tight containers.
Storage—Light-resistant.

Furosemide Injection

フロセミド注射液

Furosemide Injection is an aqueous injection.

It contains not less than 95.0% and not more than 105.0% of the labeled amount of furosemide ($\text{C}_{12}\text{H}_{11}\text{ClN}_2\text{O}_5\text{S}$: 330.74).

Method of preparation Prepare as directed under Injection, with Furosemide.

Description Furosemide Injection is a colorless, clear liquid.

Identification (1) To a volume of Furosemide Injection, equivalent to 2.5 mg of Furosemide, add 10 mL of 2 mol/L hydrochloric acid TS, heat under a reflux condenser on a water bath for 15 minutes. After cooling, render the solution slightly acid with 18 mL of sodium hydroxide TS: the solution responds to Qualitative Tests <1.09> for primary aromatic amines. The color of the solution is red to red-purple.

(2) To a volume of Furosemide Injection, equivalent to 20 mg of Furosemide, add water to make 100 mL. To 2 mL of this solution add 0.01 mol/L sodium hydroxide TS to make 50 mL. Determine the absorption spectrum of this solution as directed under Ultraviolet-visible Spectrophotometry <2.24>: it exhibits maxima between 227 nm and 231 nm, between 269 nm and 273 nm, and between 330 nm and 336 nm.

Osmotic pressure ratio Being specified separately when the drug is granted approval based on the Law.

pH Being specified separately when the drug is granted approval based on the Law.

Purity Pipet a volume of Furosemide Injection, equivalent to 40 mg of Furosemide, add 30 mL of acetone, shake well, and add acetone to make exactly 50 mL. Centrifuge this solution, to 1.0 mL of the supernatant liquid add 3.0 mL of

water, cool in a ice bath, add 3.0 mL of dilute hydrochloric acid and 0.15 mL of sodium nitrite TS, shake, and allow to stand for 1 minute. To this solution add 1.0 mL of ammonium amidosulfate TS, shake well, allow to stand for 3 minutes, add 1.0 mL of *N,N*-diethyl-*N'*-1-naphthylethylenediamine oxalate TS, shake well, and allow to stand for 5 minutes. Determine the absorbance of this solution at 530 nm as directed under Ultraviolet-visible Spectrophotometry <2.24> using a solution, prepared in the same manner with 1.0 mL of acetone, as the blank: the absorbance is not more than 0.10.

Bacterial endotoxins <4.01> Less than 1.25 EU/mg.

Extractable volume <6.05> It meets the requirement.

Foreign insoluble matter <6.06> Perform the test according to Method 1: it meets the requirement.

Insoluble particulate matter <6.07> It meets the requirement.

Sterility <4.06> Perform the test according to the Membrane filtration method: it meets the requirement.

Assay To an exactly measured volume of Furosemide Injection, equivalent to about 20 mg of Furosemide ($\text{C}_{12}\text{H}_{11}\text{ClN}_2\text{O}_5\text{S}$), add water to make exactly 100 mL. Pipet 3 mL of this solution, add 0.01 mol/L sodium hydrochloride TS to make exactly 100 mL, and use this solution as the sample solution. Separately, weigh accurately about 20 mg of Furosemide RS, previously dried at 105°C for 4 hours, add 0.01 mol/L sodium hydroxide TS to make exactly 100 mL. Pipet 3 mL of this solution, add 0.01 mol/L sodium hydroxide TS to make exactly 100 mL, and use this solution as the standard solution. Perform the test with the sample solution and standard solution as directed under Ultraviolet-visible Spectrophotometry <2.24>, and determine the absorbances, A_T and A_S , at 271 nm.

Amount (mg) of furosemide ($\text{C}_{12}\text{H}_{11}\text{ClN}_2\text{O}_5\text{S}$)
= $M_S \times A_T / A_S$

M_S : Amount (mg) of Furosemide RS taken

Containers and storage Containers—Hermetic containers.
Storage—Light-resistant.

Furosemide Tablets

フロセミド錠

Furosemide Tablets contain not less than 95.0% and not more than 105.0% of the labeled amount of furosemide ($\text{C}_{12}\text{H}_{11}\text{ClN}_2\text{O}_5\text{S}$: 330.74).

Method of preparation Prepare as directed under Tablets, with Furosemide.

Identification (1) Shake well a quantity of powdered Furosemide Tablets, equivalent to 0.2 g of Furosemide, with 40 mL of acetone, and filter. To 0.5 mL of the filtrate add 10 mL of 2 mol/L hydrochloric acid TS, and heat under a reflux condenser on a water bath for 15 minutes. After cooling, add 18 mL of sodium hydroxide TS to make the solution slightly acidic: the solution responds to Qualitative Tests <1.09> for primary aromatic amines, producing a red to red-purple color.

(2) Determine the absorption spectrum of the sample solution obtained in the Assay as directed under Ultraviolet-visible Spectrophotometry <2.24>: it exhibits maxima be-

tween 227 nm and 231 nm, between 269 nm and 273 nm, and between 330 nm and 336 nm.

Purity To a quantity of powdered Furosemide Tablets, equivalent to 40 mg of Furosemide, add about 30 mL of acetone, shake well, and add acetone to make exactly 50 mL. Centrifuge the solution, add 3.0 mL of water to 1.0 mL of the supernatant liquid, cool in ice, add 3.0 mL of dilute hydrochloric acid and 0.15 mL of sodium nitrite TS, shake, and allow to stand for 1 minute. Add 1.0 mL of ammonium amidosulfate TS, shake well, allow to stand for 3 minutes, add 1.0 mL of *N,N*-diethyl-*N'*-1-naphthylethylenediamine oxalate TS, shake well, and allow to stand for 5 minutes. Perform the test with this solution as directed under Ultraviolet-visible Spectrophotometry <2.24>, using a solution prepared in the same manner with 1.0 mL of acetone as the blank: the absorbance at 530 nm is not more than 0.10.

Uniformity of dosage units <6.02> Perform the Mass variation test, or the Content uniformity test according to the following method: it meets the requirement.

To 1 tablet of Furosemide Tablets add a suitable amount of 0.05 mol/L sodium hydroxide TS, shake to disintegrate, then add 0.05 mol/L sodium hydroxide TS to make exactly *V* mL so that each mL contains about 0.4 mg of furosemide (C₁₂H₁₁ClN₂O₅S). Filter the solution, discard the first 10 mL of the filtrate, pipet 2 mL of the subsequent filtrate, add 0.05 mol/L sodium hydroxide TS to make exactly 100 mL, and use this solution as the sample solution. Proceed as directed in the Assay.

$$\begin{aligned} \text{Amount (mg) of furosemide (C}_{12}\text{H}_{11}\text{ClN}_{2}\text{O}_{5}\text{S)} \\ = M_S \times A_T/A_S \times V/50 \end{aligned}$$

M_S: Amount (mg) of Furosemide RS taken

Dissolution <6.10> When the test is performed at 50 revolutions per minute according to the Paddle method, using 900 mL of 2nd fluid for dissolution test as the dissolution medium, the dissolution rates of a 20-mg tablet in 15 minutes and a 40-mg tablet in 30 minutes are not less than 80%.

Start the test with 1 tablet of Furosemide Tablets, withdraw not less than 30 mL of the medium at the specified minute after starting the test, and filter through a membrane filter with a pore size not exceeding 0.45 μm. Discard not less than 10 mL of the first filtrate, pipet *V* mL of the subsequent filtrate, add the dissolution medium to make exactly *V'* mL so that each mL contains about 10 μg of furosemide (C₁₂H₁₁ClN₂O₅S), and use this solution as the sample solution. Separately, weigh accurately about 20 mg of Furosemide RS, previously dried at 105°C for 4 hours, and dissolve in 5 mL of methanol, and add the dissolution medium to make exactly 100 mL. Pipet 5 mL of this solution, add the dissolution medium to make exactly 100 mL, and use this solution as the standard solution. Determine the absorbances, *A_T* and *A_S*, of the sample solution and standard solution at 277 nm as directed under Ultraviolet-visible Spectrophotometry <2.24>.

Dissolution rate (%) with respect to the labeled amount of furosemide (C₁₂H₁₁ClN₂O₅S)

$$= M_S \times A_T/A_S \times V'/V \times 1/C \times 45$$

M_S: Amount (mg) of Furosemide RS taken

C: Labeled amount (mg) of furosemide (C₁₂H₁₁ClN₂O₅S) in 1 tablet

Assay Weigh accurately the mass of not less than 20 Furosemide Tablets, and powder. Weigh accurately a portion of the powder, equivalent to about 40 mg of furosemide (C₁₂H₁₁ClN₂O₅S), add about 70 mL of 0.05 mol/L sodium

hydroxide TS, shake well, and add 0.05 mol/L sodium hydroxide TS to make exactly 100 mL. Filter, discard the first 10 mL of the filtrate, pipet 2 mL of the subsequent filtrate, add 0.05 mol/L sodium hydroxide TS to make exactly 100 mL, and use this solution as the sample solution. Separately, weigh accurately about 20 mg of Furosemide RS, previously dried at 105°C for 4 hours, and dissolve in 0.05 mol/L sodium hydroxide TS to make exactly 50 mL. Pipet 2 mL of this solution, add 0.05 mol/L sodium hydroxide TS to make exactly 100 mL, and use this solution as the standard solution. Determine the absorbances, *A_T* and *A_S*, of the sample solution and standard solution at 271 nm as directed under the Ultraviolet-visible Spectrophotometry <2.24>.

$$\begin{aligned} \text{Amount (mg) of furosemide (C}_{12}\text{H}_{11}\text{ClN}_{2}\text{O}_{5}\text{S)} \\ = M_S \times A_T/A_S \times 2 \end{aligned}$$

M_S: Amount (mg) of Furosemide RS taken

Containers and storage Containers—Tight containers.

Storage—Light-resistant.

Fursultiamine Hydrochloride

フルスルチアミン塩酸塩

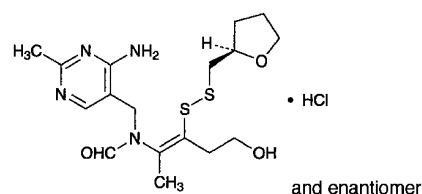

C₁₇H₂₆N₄O₃S₂·HCl: 435.00

N-(4-Amino-2-methylpyrimidin-5-ylmethyl)-*N*-{(1*Z*)-4-hydroxy-1-methyl-2-[(2*RS*)-tetrahydrofuran-2-ylmethyl]disulfanyl]but-1-en-1-yl}formamide monohydrochloride
[804-30-8, Fursultiamine]

Fursultiamine Hydrochloride contains not less than 98.5% of fursultiamine hydrochloride (C₁₇H₂₆N₄O₃S₂·HCl), calculated on the anhydrous basis.

Description Fursultiamine Hydrochloride occurs as white, crystals or crystalline powder. It is odorless or has a characteristic odor, and has a bitter taste.

It is freely soluble in water, in methanol and in ethanol (95).

It shows crystal polymorphism.

Identification (1) Dissolve 5 mg of Fursultiamine Hydrochloride in 6 mL of 0.1 mol/L hydrochloric acid TS, add 0.1 g of zinc powder, allow to stand for several minutes, and filter. To 3 mL of the filtrate, add 3 mL of sodium hydroxide TS and 0.5 mL of potassium hexacyanoferrate (III) TS, then add 5 mL of 2-methyl-1-propanol, shake vigorously for 2 minutes, allow to stand to separate the 2-methyl-1-propanol layer, and examine under ultraviolet light (main wavelength: 365 nm): the 2-methyl-1-propanol layer shows a blue-purple fluorescence. The fluorescence disappears by acidifying, and appears again by alkalifying.

(2) Determine the infrared absorption spectrum of Fursultiamine Hydrochloride, previously dried in a desiccator (in vacuum, phosphorus (V) oxide) for 24 hours, as directed in the potassium bromide disk method under Infrared Spectrophotometry <2.25>, and compare the spectrum with the Reference Spectrum or the spectrum of Fursultiamine Hy-

drochloride RS, previously dried in a desiccator (in vacuum, phosphorus (V) oxide) for 24 hours: both spectra exhibit similar intensities of absorption at the same wave numbers. If any differences appear, dissolve the Fursultiamine Hydrochloride in water, evaporate the water, and dry the residue in a desiccator (in vacuum, phosphorus (V) oxide) for 24 hours, and repeat the test.

(3) A solution of Fursultiamine Hydrochloride (1 in 50) responds to Qualitative Tests <1.09> (2) for chloride.

Purity (1) Clarity and color of solution—Dissolve 1.0 g of Fursultiamine Hydrochloride in 20 mL of water: the solution is clear and colorless.

(2) Sulfate <1.14>—Proceed with 1.5 g of Fursultiamine Hydrochloride, and perform the test. Prepare the control solution with 0.35 mL of 0.005 mol/L sulfuric acid VS (not more than 0.011%).

(3) Heavy metals <1.07>—Proceed with 1.0 g of Fursultiamine Hydrochloride according to Method 2, and perform the test. Prepare the control solution with 2.0 mL of Standard Lead Solution (not more than 20 ppm).

(4) Related substances—Dissolve 0.10 g of Fursultiamine Hydrochloride in 100 mL of the mobile phase, and use this solution as the sample solution. Pipet 1 mL of the sample solution, add the mobile phase to make exactly 100 mL, and use this solution as the standard solution. Perform the test with exactly 10 μ L each of the sample solution and standard solution as directed under Liquid Chromatography <2.01> according to the following condition. Determine each peak area of each solution by the automatic integration method: the total area of the peaks other than fursultiamine obtained from the sample solution is not larger than the peak area of fursultiamine from the standard solution.

Operating conditions—

Detector, column, column temperature, mobile phase, flow rate, and selection of column: Proceed as directed in the operating conditions in the Assay.

Detection sensitivity: Adjust the detection sensitivity so that the peak height of fursultiamine from 10 μ L of the standard solution is between 20 mm and 30 mm.

Time span of measurement: About 3 times as long as the retention time of fursultiamine.

Water <2.48> Not more than 5.0% (0.3 g, volumetric titration, direct titration).

Residue on ignition <2.44> Not more than 0.1% (1 g).

Assay Weigh accurately about 55 mg each of Fursultiamine Hydrochloride and Fursultiamine Hydrochloride RS (previously determined the water <2.48> in the same manner as Fursultiamine Hydrochloride) and dissolve each in 50 mL of water, and add exactly 10 mL each of the internal standard solution, then add water to make exactly 100 mL. To 8 mL each of the solution add water to make 50 mL, and use these solutions as the sample solution and the standard solution, respectively. Perform the test with 10 μ L each of the sample solution and standard solution as directed under Liquid Chromatography <2.01> according to the following conditions, and calculate the ratios, Q_T and Q_S , of the peak area of fursultiamine to that of the internal standard.

$$\begin{aligned} & \text{Amount (mg) of fursultiamine hydrochloride} \\ & (\text{C}_{17}\text{H}_{26}\text{N}_4\text{O}_3\text{S}_2 \cdot \text{HCl}) \\ & = M_S \times Q_T / Q_S \end{aligned}$$

M_S : Amount (mg) of Fursultiamine Hydrochloride RS taken, calculated on the anhydrous basis

Internal standard solution—A solution of isopropyl 4-

aminobenzoate in ethanol (95) (3 in 400).

Operating conditions—

Detector: An ultraviolet absorption photometer (wavelength: 254 nm).

Column: A stainless steel column about 4 mm in inside diameter and about 15 cm in length, packed with octadecylsilylated silica gel for liquid chromatography (5 μ m in particle diameter).

Column temperature: A constant temperature of about 50°C.

Mobile phase: Dissolve 1.01 g of sodium 1-heptane sulfonate in 1000 mL of diluted acetic acid (100) (1 in 100). To 675 mL of this solution add 325 mL of a mixture of methanol and acetonitrile (3:2).

Flow rate: Adjust so that the retention time of Fursultiamine is about 9 minutes.

Selection of column: Proceed with 10 μ L of the standard solution under the above operating conditions and calculate the resolution. Use a column giving elution of fursultiamine and the internal standard in this order with the resolution between these peaks being not less than 10.

Containers and storage Containers—Tight containers.

Gabexate Mesilate

ガベキサートメシル酸塩

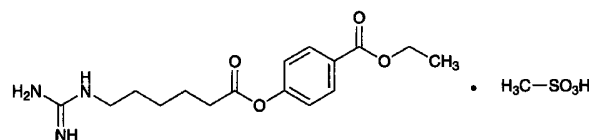

$\text{C}_{16}\text{H}_{23}\text{N}_3\text{O}_4 \cdot \text{CH}_3\text{O}_3\text{S}$: 417.48

Ethyl 4-(6-guanidinohexanoyloxy)benzoate
monomethanesulfonate
[56974-61-9]

Gabexate Mesilate, when dried, contains not less than 98.5% and not more than 101.0% of gabexate mesilate ($\text{C}_{16}\text{H}_{23}\text{N}_3\text{O}_4 \cdot \text{CH}_3\text{O}_3\text{S}$).

Description Gabexate Mesilate occurs as white, crystals or crystalline powder.

It is very soluble in water, freely soluble in ethanol (95).

Identification (1) To 4 mL of a solution of Gabexate Mesilate (1 in 2000) add 2 mL of 1-naphthol TS and 1 mL of diacetyl TS, and allow to stand for 10 minutes: a red color develops.

(2) Dissolve 1 g of Gabexate Mesilate in 5 mL of water, add 2 mL of sodium hydroxide TS, and heat in a water bath for 5 minutes. After cooling, add 2 mL of dilute nitric acid and 5 mL of ethanol (95), shake, add 5 drops of iron (III) chloride TS, and shake: a purple color develops.

(3) Determine the absorption spectrum of a solution of Gabexate Mesilate (1 in 100,000) as directed under Ultraviolet-visible Spectrophotometry <2.24>, and compare the spectrum with the Reference Spectrum or the spectrum of a solution of Gabexate Mesilate RS prepared in the same manner as the sample solution: both spectra exhibit similar intensities of absorption at the same wavelengths.

(4) A 0.1 g portion of Gabexate Mesilate responds to Qualitative Tests <1.09> (1) for mesilate.

pH <2.54> Dissolve 1.0 g of Gabexate Mesilate in 10 mL of water: the pH of the solution is between 4.7 and 5.7.

Melting point <2.60> 90 – 93°C

Purity (1) Clarity and color of solution—Dissolve 1.0 g of Gabexate Mesilate in 10 mL of water: the solution is clear and colorless.

(2) Heavy metals <1.07>—Proceed with 2.0 g of Gabexate Mesilate according to Method 1, and perform the test. Prepare the control solution with 2.0 mL of Standard Lead Solution (not more than 10 ppm).

(3) Arsenic <1.11>—Dissolve 2.0 g of Gabexate Mesilate in 20 mL of 1 mol/L hydrochloric acid TS by heating in a water bath, and continue the heating for 20 minutes. After cooling, centrifuge, and use 10 mL of the supernatant liquid as the test solution. Perform the test (not more than 2 ppm).

(4) Ethyl parahydroxybenzoate—Weigh 50 mg of Gabexate Mesilate, previously dried, and dissolve in dilute ethanol to make exactly 100 mL. Pipet 5 mL of this solution, add exactly 5 mL of the internal standard solution, and use this solution as the sample solution. Separately, dissolve 5.0 mg of ethyl parahydroxybenzoate in dilute ethanol to make exactly 100 mL. Pipet 1 mL of this solution, and add dilute ethanol to make exactly 20 mL. To exactly 5 mL of this solution add exactly 5 mL of the internal standard solution, and use this solution as the standard solution. Perform the test with 3 μ L each of the sample solution and standard solution as directed under Liquid Chromatography <2.01> according to the following conditions, and calculate the ratios, Q_T and Q_S , of the peak area of ethyl parahydroxybenzoate to that of the internal standard: Q_T is not larger than Q_S .

Internal standard solution—A solution of butyl parahydroxybenzoate in dilute ethanol (1 in 5000).

Operating conditions—

Proceed as directed in the operating conditions in the Assay.

System suitability—

Proceed as directed in the system suitability in the Assay.

(5) Related substances—Dissolve 0.20 g of Gabexate Mesilate in 5 mL of ethanol (95), and use this solution as the sample solution. Pipet 1 mL of the sample solution, add ethanol (95) to make exactly 100 mL, and use this solution as the standard solution. Perform the test with these solutions as directed under Thin-layer Chromatography <2.03>. Spot 5 μ L each of the sample solution and standard solution on a plate of silica gel for thin-layer chromatography. Develop the plate with a mixture of ethyl acetate, water and acetic acid (100) (3:1:1) to a distance of about 10 cm, and air-dry the plate until it has no acetic odor. Spray evenly a solution of 8-quinolinol in acetone (1 in 1000) on the plate, and after air-drying, spray evenly bromine-sodium hydroxide TS: the spots other than the principal spot obtained from the sample solution are not more intense than the spot from the standard solution.

Loss on drying <2.41> Not more than 0.30% (1 g, in vacuum, silica gel, 4 hours).

Residue on ignition <2.44> Not more than 0.1% (1 g).

Assay Weigh accurately about 50 mg each of Gabexate Mesilate and Gabexate Mesilate RS, previously dried, and dissolve each in dilute ethanol to make exactly 100 mL. Pipet 5 mL each of these solutions, add exactly 5 mL each of the internal standard solution, and use these solutions as the sample solution and the standard solution, respectively. Perform the test with 3 μ L each of the sample solution and standard solution as directed under Liquid Chromatography <2.01> according to the following conditions, and calculate the ratios, Q_T and Q_S , of the peak area of gabexate to that of the internal standard.

Amount (mg) of gabexate mesilate ($C_{16}H_{23}N_3O_4 \cdot CH_4O_3S$)
= $M_S \times Q_T / Q_S$

M_S : Amount (mg) of Gabexate Mesilate RS taken

Internal standard solution—A solution of butyl parahydroxybenzoate in dilute ethanol (1 in 5000).

Operating conditions—

Detector: An ultraviolet absorption photometer (wavelength: 245 nm).

Column: A stainless steel column 4.6 mm in inside diameter and 15 cm in length, packed with octadecylsilanized silica gel for liquid chromatography (5 μ m in particle diameter).

Column temperature: A constant temperature of about 25°C.

Mobile phase: A mixture of methanol, a solution of sodium lauryl sulfate (1 in 1000), a solution of sodium 1-heptane sulfonate (1 in 200) and acetic acid (100) (540:200:20:1).

Flow rate: Adjust so that the retention time of gabexate is about 13 minutes.

System suitability—

System performance: When the procedure is run with 3 μ L of the standard solution under the above operating conditions, the internal standard and gabexate are eluted in this order with the resolution between these peaks being not less than 5.

System repeatability: When the test is repeated 6 times with 3 μ L of the standard solution under the above operating conditions, the relative standard deviation of the ratios of the peak area of gabexate to that of the internal standard is not more than 1.0%.

Containers and storage Containers—Tight containers.

β -Galactosidase (Aspergillus)

β -ガラクトシダーゼ (アスペルギルス)

[9031-11-2]

β -Galactosidase (Aspergillus) contains an enzyme produced by *Aspergillus oryzae*. It is an enzyme drug having lactose decomposition activity.

It contains 8,000 to 12,000 units per g.

Usually, it is diluted with a mixture of Maltose Hydrate and Dextrin, Maltose Hydrate and D-Mannitol, or Maltose Hydrate, Dextrin and D-Mannitol.

Description β -Galactosidase (Aspergillus) occurs as a white to light yellow powder.

It is slightly soluble in water with a turbidity, and practically insoluble in ethanol (95) and in diethyl ether.

Identification (1) Dissolve 25 mg of β -Galactosidase (Aspergillus) in 100 mL of water, then to 1 mL of this solution add 9 mL of lactose substrate TS, and stand at 30°C for 10 minutes. To 1 mL of this solution add 6 mL of glucose detection TS, and stand at 30°C for 10 minutes: a red to red-purple color develops.

(2) Dissolve 0.1 g of β -Galactosidase (Aspergillus) in 100 mL of water, and filter the solution if necessary. Determine the absorption spectrum of the solution as directed under Ultraviolet-visible Spectrophotometry <2.24>, and compare the spectrum with the Reference Spectrum: both spectra exhibit similar intensities of absorption at the same wavelengths.

Purity (1) Odor— β -Galactosidase (Aspergillus) has no

any rancid odor.

(2) Heavy metals <1.07>—Proceed with 1.0 g of β -Galactosidase (Aspergillus) according to Method 2, and perform the test. Prepare the control solution with 2.0 mL of Standard Lead Solution (not more than 20 ppm).

(3) Arsenic <1.11>—Prepare the test solution with 1.0 g of β -Galactosidase (Aspergillus) according to Method 3, and perform the test (not more than 2 ppm).

Loss on drying <2.41> Not more than 9.0% (0.5 g, in vacuum, 80°C, 4 hours).

Residue on ignition <2.44> Not more than 3% (0.5 g).

Nitrogen content Weigh accurately about 70 mg of β -Galactosidase (Aspergillus), and perform the test as directed under Nitrogen Determination <1.08>: the amount of nitrogen (N: 14.01) is between 0.5% and 5.0%, calculated on the dried basis.

Assay (i) Substrate solution—Dissolve 0.172 g of 2-nitrophenyl- β -D-galactopyranoside in disodium hydrogenphosphate-citric acid buffer solution (pH 4.5) to make 100 mL.

(ii) Procedure—Weigh accurately about 25 mg of β -Galactosidase (Aspergillus), dissolve in water to make exactly 100 mL, then pipet 2 mL of this solution, add water to make exactly 50 mL, and use this solution as the sample solution. Take exactly 3.5 mL of the substrate solution, stand at $30 \pm 0.1^\circ\text{C}$ for 5 minutes, add exactly 0.5 mL of the sample solution, immediately mix, and stand at $30 \pm 0.1^\circ\text{C}$ for exactly 10 minutes, then add exactly 1 mL of sodium carbonate TS and mix immediately. Perform the test as directed under Ultraviolet-visible Spectrophotometry <2.24>, and determine the absorbance, A_1 , of this solution at 420 nm using water as the control. Separately, take exactly 3.5 mL of the substrate solution, add exactly 1 mL of sodium carbonate TS and mix, then add exactly 0.5 mL of the sample solution and mix. Determine the absorbance, A_2 , of this solution in the same manner as above.

$$\begin{aligned} \text{Units per g of } \beta\text{-Galactosidase (Aspergillus)} \\ = 1/M \times (A_1 - A_2)/0.917 \times 1/0.5 \times 1/10 \end{aligned}$$

0.917: Absorbance of 1 $\mu\text{mol}/5$ mL of *o*-nitrophenol

M: Amount (g) of β -Galactosidase (Aspergillus) in the sample solution per mL

Unit: One unit indicates an amount of the enzyme which decomposes 1 μmol of 2-nitrophenyl- β -D-galactopyranoside in 1 minute under the above conditions.

Containers and storage Containers—Tight containers.

Storage—In a cold place.

β -Galactosidase (Penicillium)

β -ガラクトシダーゼ (ペニシリウム)

[9031-11-2]

β -Galactosidase (Penicillium) contains an enzyme, having lactose decomposition activity, produced by *Penicillium multicolor*.

It contains not less than 8500 units and not more than 11,500 units in each g.

Usually, it is diluted with D-Mannitol.

Description β -Galactosidase (Penicillium) occurs as a white

to pale yellow-white, crystalline powder or powder.

It is soluble in water with a turbidity, and practically insoluble in ethanol (95).

It is hygroscopic.

Identification (1) Dissolve 0.05 g of β -Galactosidase (Penicillium) in 100 mL of water, then to 0.2 mL of this solution add 0.2 mL of lactose substrate TS for β -galactosidase (penicillium), and allow to stand at 30°C for 10 minutes. To this solution add 3 mL of glucose detection TS for penicillium origin β -galactosidase, and allow to stand at 30°C for 10 minutes: a red to red-purple color develops.

(2) Dissolve 0.15 g of β -Galactosidase (Penicillium) in 100 mL of water, filter if necessary, and determine the absorption spectrum of this solution as directed under Ultraviolet-visible Spectrophotometry <2.24>: it exhibits a maximum between 278 nm and 282 nm.

Purity (1) Odor— β -Galactosidase (Penicillium) has no any rancid odor.

(2) Heavy metals <1.07>—Proceed with 1.0 g of β -Galactosidase (Penicillium) according to Method 2, and perform the test. Prepare the control solution with 2.0 mL of Standard Lead Solution (not more than 20 ppm).

(3) Arsenic <1.11>—Prepare the test solution with 1.0 g of β -Galactosidase (Penicillium) according to Method 3, and perform the test (not more than 2 ppm).

(4) Nitrogen—Weigh accurately about 0.1 g of β -Galactosidase (Penicillium), and perform the test as directed under Nitrogen Determination <1.08>: not more than 3 mg of nitrogen (N: 14.01) is found for each labeled 1000 Units.

(5) Protein contaminants—Dissolve 0.15 g of β -Galactosidase (Penicillium) in 4 mL of water, and use this solution as the sample solution. Perform the test with 15 μL of the sample solution as directed under Liquid Chromatography <2.01> according to the following conditions, and determine each peak area by the automatic integration method: the total area of the peaks other than the peak having retention time of about 19 minutes is not more than 75% of the total area of all peaks, and the areas of peaks other than the peaks having retention times of about 3, 16 and 19 minutes are not more than 15% of the total area of all peaks.

Operating conditions—

Detector: An ultraviolet absorption photometer (wavelength: 280 nm).

Column: A stainless steel column about 7.5 mm in inside diameter and about 75 mm in length, packed with strongly acidic ion-exchange resin for liquid chromatography of sulfopropyl group-binding hydrophilic polymer (10 μm in particle diameter).

Column temperature: A constant temperature of about 20°C .

Mobile phase: A solution obtained by dissolving 2.83 g of sodium acetate in 1000 mL of water, and adjusting to pH 4.5 with acetic acid (100) (mobile phase A), and a solution obtained by dissolving 29.2 g of sodium chloride in 1000 mL of mobile phase A (mobile phase B).

Flow system: Adjust a linear concentration gradient from the mobile phase A to the mobile phase B immediately after injection of the sample so that the retention times of non-retaining protein and the enzyme protein are about 3 minutes and 19 minutes, respectively, when the flow runs 0.8 mL per minute, and then continue the running of the mobile phase B.

Selection of column: Dissolve 15 mg of β -lactoglobulin in 4.5 mL of water, add 0.5 mL of a solution of cytosine (1 in 5000), and use this solution as the column-selecting solution. Proceed with 15 μL of the column-selecting solution under

the above operating conditions, and calculate the resolution. Use a column giving elution of cytosine and β -lactoglobulin in this order with the resolution between these peaks being not less than 4.

Detection sensitivity: Adjust the detection sensitivity so that the peak height of β -lactoglobulin from 15 μ L of the column-selecting solution is between 5 cm and 14 cm.

Time span of measurement: About 1.4 times as long as the retention time of β -lactoglobulin.

Loss on drying <2.41> Not more than 5.0% (0.5 g, in vacuum, phosphorus (V) oxide, 4 hours).

Residue on ignition <2.44> Not more than 2% (1 g).

Assay (i) Substrate solution—Dissolve 0.603 g of 2-nitrophenyl- β -D-galactopyranoside in disodium hydrogen phosphate-citric acid buffer solution for penicillium origin β -galactosidase (pH 4.5) to make 100 mL.

(ii) Procedure—Weigh accurately about 0.15 g of β -Galactosidase (Penicillium), dissolve in water with thorough shaking to make exactly 100 mL, and allow to stand at room temperature for an hour. Pipet 2 mL of this solution, add disodium hydrogen phosphate-citric acid buffer solution for penicillium origin β -galactosidase (pH 4.5) to make exactly 100 mL, and use this solution as the sample solution. Transfer exactly 0.5 mL of the sample solution to a test tube, stand at $30 \pm 0.1^\circ\text{C}$ for 10 minutes, add exactly 0.5 mL of the substrate solution previously kept at $30 \pm 0.1^\circ\text{C}$, then mix immediately, and stand at $30 \pm 0.1^\circ\text{C}$ for exactly 10 minutes. Then add exactly 1 mL of sodium carbonate TS, mix immediately to stop the reaction. To this solution add exactly 8 mL of water, mix, and use as the colored sample solution. Separately, pipet 0.5 mL of disodium hydrogen phosphate-citric acid buffer solution for penicillium origin β -galactosidase (pH 4.5), then proceed in the same manner as the sample solution, and use the solution so obtained as the colored blank solution. Perform the test with the colored sample solution and the colored blank solution as directed under Ultraviolet-visible Spectrophotometry <2.24>, using water as the blank, and determine the absorbances, A_T and A_B , at 420 nm.

$$\begin{aligned} &\text{Units per g of } \beta\text{-Galactosidase (Penicillium)} \\ &= 1/M \times (A_T - A_B)/0.459 \times 1/10 \end{aligned}$$

0.459: Absorbance of 1 μ mol/10 mL of *o*-nitrophenol

M: Amount (g) of β -Galactosidase (Penicillium) in 0.5 mL of the sample solution

Unit: One unit indicates an amount of the enzyme which decomposes 1 μ mol of 2-nitrophenyl- β -D-galactopyranoside in 1 minute under the above conditions.

Containers and storage Containers—Tight containers.

Gallium (^{67}Ga) Citrate Injection

クエン酸ガリウム (^{67}Ga) 注射液

Gallium (^{67}Ga) Citrate Injection is an aqueous injection containing gallium-67 (^{67}Ga) in the form of gallium citrate.

It conforms to the requirements of Gallium (^{67}Ga) Citrate Injection in the Minimum Requirements for Radiopharmaceuticals.

Test for Extractable volume of Parenteral Preparations and Insoluble Particulate Matter Test for Injec-

tions are not applied to this injection.

Description Gallium (^{67}Ga) Citrate Injection is a clear, colorless or light red liquid.

Gatifloxacin Hydrate

ガチフロキサシン水和物

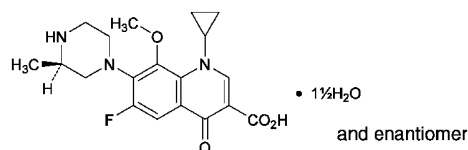

$\text{C}_{19}\text{H}_{22}\text{FN}_3\text{O}_4 \cdot 1\frac{1}{2}\text{H}_2\text{O}$: 402.42

1-Cyclopropyl-6-fluoro-8-methoxy-7-[(3*RS*)-3-methylpiperazin-1-yl]-4-oxo-1,4-dihydroquinoline-3-carboxylic acid sesquihydrate [180200-66-2]

Gatifloxacin Hydrate contains not less than 98.5% and not more than 101.5% of gatifloxacin ($\text{C}_{19}\text{H}_{22}\text{FN}_3\text{O}_4$: 375.39), calculated on the anhydrous basis.

Description Gatifloxacin Hydrate occurs as white to pale yellow, crystals or crystalline powder.

It is slightly soluble in methanol and in ethanol (99.5), and very slightly soluble in water.

It dissolves in sodium hydroxide TS.

It is gradually colored to pale yellow by light.

A solution of Gatifloxacin Hydrate in dilute sodium hydroxide TS (1 in 100) shows no optical rotation.

Identification (1) Determine the absorption spectrum of a solution of Gatifloxacin Hydrate in dilute sodium hydroxide TS (1 in 100,000) as directed under Ultraviolet-visible Spectrophotometry <2.24>, and compare the spectrum with the Reference Spectrum or the spectrum of a solution of Gatifloxacin RS prepared in the same manner as the sample solution: both spectra exhibit similar intensities of absorption at the same wavelengths.

(2) Determine the infrared absorption spectrum of Gatifloxacin Hydrate as directed in the potassium bromide disk method under Infrared Spectrophotometry <2.25>, and compare the spectrum with the Reference Spectrum or the spectrum of Gatifloxacin RS: both spectra exhibit similar intensities of absorption at the same wave numbers.

Purity (1) Clarity and color of solution—Dissolve 1.0 g of Gatifloxacin Hydrate in 10 mL of sodium hydroxide TS: the solution is clear. Perform the test with the solution as directed under Methods for Color Matching <2.65>: the solution is not more colored than diluted Matching Fluid O (1 in 5).

(2) Heavy metals <1.07>—Proceed with 1.0 g of Gatifloxacin Hydrate according to Method 4, and perform the test. Prepare the control solution with 2.0 mL of Standard Lead Solution (not more than 20 ppm).

(3) Related substances—Dissolve 20 mg of Gatifloxacin Hydrate in 50 mL of the dissolving solution, and use this solution as the sample solution. Pipet 1 mL of the sample solution, and add the dissolving solution to make exactly 100 mL. Pipet 2 mL of this solution, add the dissolving solution to make exactly 20 mL, and use this solution as the standard solution. Perform the test with exactly 20 μ L each of the sample solution and standard solution as directed under Liquid Chromatography <2.01> according to the following con-

ditions. Determine each peak area by the automatic integration method: the peak area of the related substance A, having the relative retention time of about 1.2 to gatifloxacin, obtained from the sample solution is not larger than 2 times the peak area of gatifloxacin from the standard solution, and the area of the peak other than gatifloxacin and the peak mentioned above from the sample solution is not larger than the peak area of gatifloxacin from the standard solution. Furthermore, the total area of the peaks other than gatifloxacin from the sample solution is not larger than 3 times the peak area of gatifloxacin from the standard solution.

Dissolving solution: A mixture of diluted phosphoric acid (1 in 1000) and acetonitrile (4:1).

Operating conditions—

Detector: An ultraviolet absorption photometer (wavelength: 325 nm).

Column: A stainless steel column 4.6 mm in inside diameter and 15 cm in length, packed with octadecylsilanized silica gel for liquid chromatography (5 μ m in particle diameter).

Column temperature: A constant temperature of about 35°C.

Mobile phase A: A mixture of diluted triethylamine (1 in 100), adjusted to pH 4.3 with phosphoric acid, and acetonitrile (22:3).

Mobile phase B: A mixture of diluted triethylamine (1 in 100), adjusted to pH 4.3 with phosphoric acid, and acetonitrile (1:1).

Flowing of mobile phase: Control the gradient by mixing the mobile phases A and B as directed in the following table.

Time after injection of sample (min)	Mobile phase A (vol%)	Mobile phase B (vol%)
0 - 15	100	0
15 - 30	100 \rightarrow 0	0 \rightarrow 100
30 - 40	0	100

Flow rate: 1.0 mL per minute (the retention time of gatifloxacin is about 16 minutes).

Time span of measurement: About 2.5 times as long as the retention time of gatifloxacin, beginning after the solvent peak.

System suitability—

Test for required detectability: Pipet 5 mL of the standard solution, and add the dissolving solution to make exactly 10 mL. Confirm that the peak area of gatifloxacin obtained with 20 μ L of this solution is equivalent to 40 to 60% of that with 20 μ L of the standard solution.

System performance: Dissolve 20 mg of methyl 4-aminobenzoate in 50 mL of the dissolving solution. To 5 mL of this solution add 1 mL of the sample solution and the dissolving solution to make 100 mL. When the procedure is run with 20 μ L of this solution under the above operating conditions, gatifloxacin and methyl 4-aminobenzoate are eluted in this order with the resolution between these peaks being not less than 4.

System repeatability: When the test is repeated 6 times with 20 μ L of the standard solution under the above operating conditions, the relative standard deviation of the peak area of gatifloxacin is not more than 3.0%.

Water <2.48> 6.0 - 9.0% (0.1 g, volumetric titration, direct titration).

Residue on ignition <2.44> Not more than 0.1% (1 g).

Assay Weigh accurately about 50 mg of Gatifloxacin Hydrate and Gatifloxacin RS (separately determine the water

<2.48> in the same manner as Gatifloxacin Hydrate), and dissolve each in the dissolving solution to make exactly 100 mL. Pipet 2 mL each of these solution, add exactly 2 mL of the internal standard solution to them, add the dissolving solution to make 25 mL, and use these solutions as the sample solution and standard solutions. Perform the test with 20 μ L each of the sample solution and standard solution as directed under Liquid Chromatography <2.01> according to the following conditions, and calculate the ratios, Q_T and Q_S , of the peak area of gatifloxacin to that of the internal standard.

$$\begin{aligned} &\text{Amount (mg) of gatifloxacin (C}_{19}\text{H}_{22}\text{FN}_3\text{O}_4) \\ &= M_S \times Q_T / Q_S \end{aligned}$$

M_S : Amount (mg) of Gatifloxacin RS taken, calculated on the anhydrous basis

Internal standard solution—A solution of methyl 4-aminobenzoate in the dissolving solution (1 in 4000).

Dissolving solution: A mixture of diluted phosphoric acid (1 in 1000) and acetonitrile (4:1).

Operating conditions—

Detector: An ultraviolet absorption photometer (wavelength: 280 nm).

Column: A stainless steel column 4 mm in inside diameter and 12.5 cm in length, packed with octadecylsilanized silica gel for liquid chromatography (5 μ m in particle diameter).

Column temperature: A constant temperature of about 40°C.

Mobile phase: A mixture of diluted triethylamine (1 in 100), adjusted to pH 4.5 with phosphoric acid, and acetonitrile (87:13).

Flow rate: Adjust so that the retention time of gatifloxacin is about 5 minutes.

System suitability—

System performance: When the procedure is run with 20 μ L of the standard solution under the above operating conditions, gatifloxacin and the internal standard are eluted in this order with the resolution between these peaks being not less than 4.

System repeatability: When the test is repeated 6 times with 20 μ L of the standard solution under the above operating conditions, the relative standard deviation of the ratio of the peak area of gatifloxacin to that of the internal standard is not more than 1.0%.

Containers and storage Containers—Tight containers.

Storage—Light-resistant.

Others

Related substance A:

1-Cyclopropyl-6-fluoro-8-methoxy-7-[(2RS)-2-methylpiperazin-1-yl]-4-oxo-1,4-dihydroquinoline-3-carboxylic acid

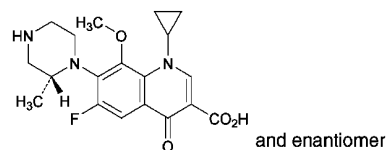

Gatifloxacin Ophthalmic Solution

ガチフロキサシン点眼液

Gatifloxacin Ophthalmic Solution is an aqueous ophthalmic preparation.

It contains not less than 95.0% and not more than 107.0% of the labeled amount of gatifloxacin ($C_{19}H_{22}FN_3O_4$; 375.39).

Method of preparation Prepare as directed under Ophthalmic Liquids and Solutions, with Gatifloxacin Hydrate.

Description Gatifloxacin Ophthalmic Solution is a clear, pale yellow liquid.

Identification To a volume of Gatifloxacin Ophthalmic Solution, equivalent to 6 mg of gatifloxacin ($C_{19}H_{22}FN_3O_4$), add diluted sodium hydroxide TS (1 in 10) to make 30 mL. To 1 mL of this solution add diluted sodium hydroxide TS (1 in 10) to make 20 mL, and determine the absorption spectrum of this solution as directed under Ultraviolet-visible Spectrophotometry <2.24>: it exhibits maxima between 238 nm and 242 nm, between 287 nm and 291 nm, and between 336 nm and 340 nm.

Osmotic pressure ratio Being specified separately when the drug is granted approval based on the Law.

pH Being specified separately when the drug is granted approval based on the Law.

Purity Related substance—To a volume of Gatifloxacin Ophthalmic Solution, equivalent to 6 mg of gatifloxacin ($C_{19}H_{22}FN_3O_4$), add the diluting solution to make 30 mL, and use this solution as the sample solution. Pipet 1 mL of the sample solution, add the diluting solution to make exactly 100 mL. Pipet 2 mL of this solution, add the diluting solution to make exactly 20 mL, and use this solution as the standard solution. Perform the test with exactly 40 μ L each of the sample solution and standard solution as directed under Liquid Chromatography <2.01> according to the following conditions. Determine each peak area by the automatic integration method: the peak area of the related substance A, having the relative retention time of about 1.2 to gatifloxacin, obtained from the sample solution is not larger than 2 times the peak area of gatifloxacin from the standard solution, and the area of the peak other than gatifloxacin and the peak mentioned above from the sample solution is not larger than the peak area of gatifloxacin from the standard solution. Furthermore, the total area of the peaks other than gatifloxacin from the sample solution is not larger than 3 times the peak area of gatifloxacin from the standard solution.

Diluting solution: A mixture of diluted phosphoric acid (1 in 1000) and acetonitrile (4:1).

Operating conditions—

Detector: An ultraviolet absorption photometer (wavelength: 325 nm).

Column: A stainless steel column 4.6 mm in inside diameter and 15 cm in length, packed with octadecylsilanized silica gel for liquid chromatography (5 μ m in particle diameter).

Column temperature: A constant temperature of about 40°C.

Mobile phase A: A mixture of diluted triethylamine (1 in 100) and acetonitrile (22:3), adjusted to pH 4.3 with phosphoric acid.

Mobile phase B: A mixture of diluted triethylamine (1 in

100) and acetonitrile (1:1), adjusted to pH 4.3 with phosphoric acid.

Flowing of mobile phase: Control the gradient by mixing the mobile phases A and B as directed in the following table.

Time after injection of sample (min)	Mobile phase A (vol%)	Mobile phase B (vol%)
0 - 15	100	0
15 - 30	100 → 0	0 → 100
30 - 40	0	100

Flow rate: 0.9 mL per minute (the retention time of gatifloxacin is about 16 minutes).

Time span of measurement: For 40 minutes after injection, beginning after the solvent peak.

System suitability—

Test for required detectability: Pipet 5 mL of the standard solution, and add the diluting solution to make exactly 10 mL. Confirm that the peak area of gatifloxacin obtained with 40 μ L of this solution is equivalent to 40 to 60% of that with 40 μ L of the standard solution.

System performance: Dissolve 20 mg of methyl 4-aminobenzoate in 100 mL of the diluting solution. To 5 mL of this solution and 1 mL of the sample solution add the diluting solution to make 100 mL. When the procedure is run with 40 μ L of this solution under the above operating conditions, gatifloxacin and methyl 4-aminobenzoate are eluted in this order with the resolution between these peaks being not less than 4.

System repeatability: When the test is repeated 6 times with 40 μ L of the standard solution under the above operating conditions, the relative standard deviation of the peak area of gatifloxacin is not more than 3.0%.

Foreign insoluble matter <6.11> It meets the requirement.

Insoluble particulate matter <6.08> It meets the requirement.

Sterility <4.06> Perform the test according to the Membrane filtration method: it meets the requirement.

Assay Pipet a volume of Gatifloxacin Ophthalmic Solution, equivalent to about 6 mg of gatifloxacin ($C_{19}H_{22}FN_3O_4$), and add the diluting solution to make exactly 30 mL. Pipet 2 mL of this solution, add exactly 3 mL of the internal standard solution, add the diluting solution to make 20 mL, and use this solution as the sample solution. Separately, weigh accurately about 22 mg of Gatifloxacin RS (separately determine the water <2.48> in the same manner as Gatifloxacin Hydrate), and dissolve in the diluting solution to make exactly 100 mL. Pipet 2 mL of this solution, add exactly 3 mL of the internal standard solution, add the diluting solution to make 20 mL, and use this solution as the standard solution. Perform the test with 20 μ L each of the sample solution and standard solution as directed under Liquid Chromatography <2.01> according to the following conditions, and calculate the ratios, Q_T and Q_S , of the peak area of gatifloxacin to that of the internal standard.

$$\begin{aligned} \text{Amount (mg) of gatifloxacin (C}_{19}\text{H}_{22}\text{FN}_3\text{O}_4) \\ = M_S \times Q_T / Q_S \times 3/10 \end{aligned}$$

M_S : Amount (mg) of Gatifloxacin RS taken, calculated on the anhydrous basis

Internal standard solution—A solution of methyl 4-aminobenzoate in the diluting solution (1 in 10,000).

Diluting solution: A mixture of diluted phosphoric acid (1

in 1000) and acetonitrile (4:1).

Operating conditions—

Detector: An ultraviolet absorption photometer (wavelength: 280 nm).

Column: A stainless steel column 4.6 mm in inside diameter and 15 cm in length, packed with octadecylsilanized silica gel for liquid chromatography (5 μ m in particle diameter).

Column temperature: A constant temperature of about 40°C.

Mobile phase: A mixture of water, acetonitrile and triethylamine (81:18:1), adjusted to pH 4.5 with phosphoric acid.

Flow rate: Adjust so that the retention time of gatifloxacin is about 6 minutes.

System suitability—

System performance: When the procedure is run with 20 μ L of the standard solution under the above operating conditions, gatifloxacin and the internal standard are eluted in this order with the resolution between these peaks being not less than 10.

System repeatability: When the test is repeated 6 times with 20 μ L of the standard solution under the above operating conditions, the relative standard deviation of the ratio of the peak area of gatifloxacin to that of the internal standard is not more than 1.0%.

Containers and storage Containers—Tight containers.

Others

Related substances A: Refer to it described in Gatifloxacin Hydrate.

Gefarnate

ゲファルナート

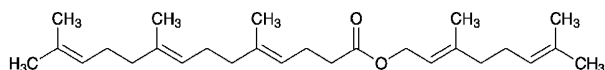

$C_{27}H_{44}O_2$: 400.64

(2*E*)-3,7-Dimethylocta-2,6-dienyl(4*E*,8*E*)-5,9,13-trimethyltetradeca-4,8,12-trienoate
[51-77-4, 4*E* isomer]

Gefarnate is a mixture of 4*E* geometrical isomer.

It contains not less than 98.0% and not more than 101.0% of gefarnate ($C_{27}H_{44}O_2$).

Description Gefarnate is a light yellow to yellow, clear oily liquid.

It is miscible with acetonitrile, with ethanol (99.5) and with cyclohexane.

It is practically insoluble in water.

Identification Determine the infrared absorption spectrum of Gefarnate as directed in the liquid film method under Infrared Spectrophotometry <2.25>, and compare the spectrum with the Reference Spectrum or the spectrum of Gefarnate RS: both spectra exhibit similar intensities of absorption at the same wave numbers.

Specific gravity <2.56> d_{20}^{20} : 0.906 – 0.914

Purity (1) Acidity—To 1.0 g of Gefarnate add 30 mL of neutralized ethanol. To this solution add 1 drop of phenolphthalein TS and 0.40 mL of 0.1 mol/L sodium hydroxide VS: a red color develops.

(2) Heavy metals <1.07>—Proceed with 2.0 g of Gefarnate according to Method 2, and perform the test. Prepare

the control solution with 2.0 mL of Standard Lead Solution (not more than 10 ppm).

(3) Related substances—Use a solution of Gefarnate in acetonitrile (1 in 500) as the sample solution. Pipet 2 mL of the sample solution, add acetonitrile to make exactly 100 mL, and use this solution as the standard solution. Perform the test with exactly 2 μ L each of the sample solution and standard solution as directed under Liquid Chromatography <2.01> according to the following conditions. Determine each peak area of both solutions by the automatic integration method: the area of each peak other than the peak of gefarnate obtained from the sample solution is not larger than 1/2 times the peak area of gefarnate from the standard solution, and the total area of the peaks other than the peak of gefarnate from the sample solution is not larger than the peak area of gefarnate from the standard solution.

Operating conditions—

Detector, column, column temperature, mobile phase and flow rate: Proceed as directed in the operating conditions in the Assay.

Time span of measurement: About 2 times as long as the retention time of gefarnate, beginning after the solvent peak.

System suitability—

Test for required detectability: Pipet 2 mL of the standard solution, add acetonitrile to make exactly 20 mL. Confirm that the peak area of gefarnate obtained with 2 μ L of this solution is equivalent to 7 to 13% of that of gefarnate with 2 μ L of the standard solution.

System performance: When the procedure is run with 2 μ L of the standard solution under the above operating conditions, the number of theoretical plates and the symmetry factor of the peak of gefarnate are not less than 4000, and between 0.9 and 1.2, respectively.

System repeatability: When the test is repeated 6 times with 2 μ L of the standard solution under the above operating conditions, the relative standard deviation of the peak area of gefarnate is not more than 1.0%.

Isomer ratio To 1 mL of Gefarnate add 100 mL of ethanol (99.5), and use this solution as the sample solution. Perform the test with 4 μ L of the sample solution as directed under Gas Chromatography <2.02> according to the following conditions. Determine the areas of two adjacent peaks, A_a and A_b , having the retention time of about 37 minutes, where A_a is the peak area of shorter retention time and A_b is the peak area of longer retention time: $A_a/(A_a + A_b)$ is between 0.2 and 0.3.

Operating conditions—

Detector: A hydrogen flame-ionization detector.

Column: A glass column 3 mm in inside diameter and 160 cm in length, packed with polyethylene glycol 20M for gas chromatography coated at the ratio of 5% on acid-treated and silanized siliceous earth for gas chromatography (149 to 177 μ m in particle diameter).

Column temperature: A constant temperature of about 210°C.

Carrier gas: Nitrogen.

Flow rate: Adjust so that the reaction time of the peak showing earlier elution of the two peaks of gefarnate is about 35 minutes.

System suitability—

System performance: When the procedure is run with 4 μ L of the sample solution under the above conditions: the resolution between the two peaks of gefarnate is not less than 1.0.

System repeatability: When the test is repeated 6 times with 4 μ L of the sample solution under the above operating

conditions: the relative standard deviation of the peak area of gefarnate with the shorter retention time of the two peaks of gefarnate is not more than 2.0%.

Assay Weigh accurately about 50 mg each of Gefarnate and Gefarnate RS, add exactly 5 mL of the internal standard solution and 20 mL of acetonitrile, and use these solutions as the sample solution and standard solution. Perform the test with 2 μ L each of the sample solution and standard solution as directed under Liquid Chromatography <2.01> according to the following conditions, and calculate the ratios, Q_T and Q_S , of the peak area of gefarnate to that of the internal standard.

$$\text{Amount (mg) of gefarnate (C}_{27}\text{H}_{44}\text{O}_2) = M_S \times Q_T / Q_S$$

M_S : Amount (mg) of Gefarnate RS taken

Internal standard solution—A solution of tris (4-*t*-butylphenyl) phosphate in acetonitrile (1 in 400).

Operating conditions—

Detector: An ultraviolet absorption photometer (wavelength: 220 nm).

Column: A stainless steel column 4 mm in inside diameter and 30 cm in length, packed with phenylsilanized silica gel for liquid chromatography (10 μ m in particle diameter).

Column temperature: A constant temperature of about 40°C.

Mobile phase: A mixture of acetonitrile for liquid chromatography, water and phosphoric acid (700:300:1).

Flow rate: Adjust so that the retention time of gefarnate is about 19 minutes.

System suitability—

System performance: When the procedure is run with 2 μ L of the standard solution under the above operating conditions, the internal standard and gefarnate are eluted in this order with the resolution between these peaks being not less than 2.0.

System repeatability: When the test is repeated 6 times with 2 μ L of the standard solution under the above operating conditions, the relative standard deviation of the ratio of the peak area of gefarnate to that of the internal standard is not more than 1.0%.

Containers and storage Containers—Tight containers.

Storage—Light-resistant, and under nitrogen atmosphere.

Gefitinib

ゲフィチニブ

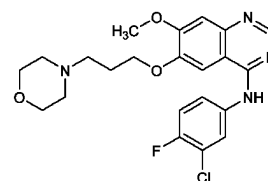

C₂₂H₂₄ClFN₄O₃: 446.90

N-(3-Chloro-4-fluorophenyl)-7-methoxy-6-[3-(morpholin-4-yl)propoxy]quinazolin-4-amine
[184475-35-2]

Gefitinib contains not less than 98.0% and not more than 102.0% of gefitinib (C₂₂H₂₄ClFN₄O₃), calculated on the anhydrous basis.

Description Gefitinib occurs as a white powder.

It is slightly soluble in ethanol (99.5), and practically insoluble in water.

Identification (1) Determine the absorption spectrum of a solution of Gefitinib in a mixture of trifluoroacetic acid solution (1 in 500) and acetonitrile (3:2) (1 in 100,000) as directed under Ultraviolet-visible Spectrophotometry <2.24>, and compare the spectrum with the Reference Spectrum or the spectrum of a solution of Gefitinib RS prepared in the same manner as the sample solution: both spectra exhibit similar intensities of absorption at the same wavelengths.

(2) Determine the infrared absorption spectrum of Gefitinib as directed in the potassium bromide disk method under Infrared Spectrometry <2.25>, and compare the spectrum with the Reference Spectrum or the spectrum of Gefitinib RS: both spectra exhibit similar intensities of absorption at the same wave numbers. Or, perform the test by the diffuse reflectance method, and compare the spectrum with the spectrum of Gefitinib RS: both spectra exhibit similar intensities of absorption at the same wave numbers.

Purity (1) Heavy metals—Being specified separately when the drug is granted approval based on the Law.

(2) Related substances—Use the sample solution obtained in the Assay as the sample solution. Pipet 1 mL of the sample solution, add a mixture of trifluoroacetic acid solution (1 in 500) and acetonitrile (3:2) to make exactly 100 mL. Pipet 1 mL of this solution, and add a mixture of trifluoroacetic acid solution (1 in 500) and acetonitrile (3:2) to make exactly 10 mL, and use this solution as the standard solution. Perform the test with exactly 5 μ L each of the sample solution and standard solution as directed under Liquid Chromatography <2.01> according to the following conditions, and determine each peak area by the automatic integration method: the peak area of related substance A having the relative retention time of about 0.13 to gefitinib obtained from the sample solution is not larger than the peak area of gefitinib from the standard solution, the peak area of related substance B having the relative retention time of about 1.3 from the sample solution is not larger than 2 times the peak area of gefitinib from the standard solution, and the area of the peak other than gefitinib and the peaks mentioned above from the sample solution is not larger than the peak area of gefitinib from the standard solution. Furthermore, the total area of the peaks other than gefitinib from the sample solution is not larger than 4 times the peak area of gefitinib from

the standard solution.

Operating conditions—

Detector, column, column temperature, mobile phase, and flow rate: Proceed as directed in the operating conditions in the Assay.

Time span of measurement: About 5 times as long as the retention time of gefitinib, beginning after the solvent peak.

System suitability—

System performance: Proceed as directed in the system suitability in the Assay.

Test for required detectability: Pipet 5 mL of the standard solution, and add a mixture of trifluoroacetic acid solution (1 in 500) and acetonitrile (3:2) to make exactly 10 mL. When the procedure is run with 5 μ L of this solution under the above operating conditions, the SN ratio of the peak of gefitinib is not less than 10.

System repeatability: When the test is repeated 6 times with 5 μ L of the standard solution under the above operating conditions, the relative standard deviation of the peak area of gefitinib is not more than 2.0%.

Water <2.48> Not more than 0.4% (0.1 g, coulometric titration).

Residue on ignition <2.44> Not more than 0.2% (1.0 g, platinum crucible).

Assay Weigh accurately about 35 mg each of Gefitinib and Gefitinib RS (separately determine the water <2.48> in the same manner as Gefitinib), add 85 mL of a mixture of trifluoroacetic acid solution (1 in 500) and acetonitrile (3:2) to each, sonicate to dissolve, add a mixture of trifluoroacetic acid solution (1 in 500) and acetonitrile (3:2) to make exactly 100 mL, and use these solutions as the sample solution and the standard solution, respectively. Perform the test with exactly 5 μ L each of the sample solution and standard solution as directed under Liquid Chromatography <2.01> according to the following conditions, and determine the peak areas, A_T and A_S , of gefitinib in each solution.

$$\begin{aligned} &\text{Amount (mg) of gefitinib (C}_{22}\text{H}_{24}\text{ClFN}_4\text{O}_3\text{)} \\ &= M_S \times A_T/A_S \end{aligned}$$

M_S : Amount (mg) of Gefitinib RS taken, calculated on the anhydrous basis

Operating conditions—

Detector: An ultraviolet absorption photometer (wavelength: 247 nm).

Column: A stainless steel column 3 mm in inside diameter and 10 cm in length, packed with octadesylsilanized silica gel for liquid chromatography (3 μ m in particle diameter).

Column temperature: A constant temperature of about 60°C.

Mobile phase: A mixture of ammonium acetate solution (3 in 310) and acetonitrile (31:19).

Flow rate: 0.9 mL per minute (the retention time of gefitinib is about 5.5 minutes).

System suitability—

System performance: Dissolve 15 mg of 3,4-dichloroaniline in 60 mL of the standard solution. When the procedure is run with 5 μ L of this solution under the above operating conditions, 3,4-dichloroaniline and gefitinib are eluted in this order with the resolution between these peaks being not less than 5.

System repeatability: When the test is repeated 6 times with 5 μ L of the standard solution under the above operating conditions, the relative standard deviation of the peak area of gefitinib is not more than 1.0%.

Containers and storage Containers—Tight containers.

Others

Related substance A:

7-Methoxy-6-[3-(morpholin-4-yl)propoxy]quinazolin-4(3H)-one

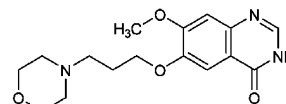

Related substance B:

N-(4-Chloro-3-fluorophenyl)-7-methoxy-6-[3-(morpholin-4-yl)propoxy]quinazolin-4-amine

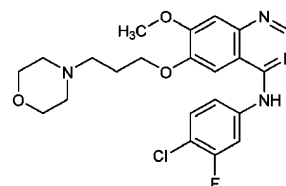

Gelatin

ゼラチン

This monograph is harmonized with the European Pharmacopoeia and the U.S. Pharmacopoeia.

The corresponding part of the attributes/provisions which are agreed as non-harmonized within the scope of the harmonization is marked with symbols (◆ ◆), and the corresponding parts which are agreed as the JP local requirement other than the scope of the harmonization are marked with symbols (◇ ◇).

Information on the harmonization with the European Pharmacopoeia and the U.S. Pharmacopoeia is available on the website of the Pharmaceuticals and Medical Devices Agency.

Gelatin is a purified protein obtained from collagen of animals by partial alkaline and/or acid hydrolysis, and/or enzymatic hydrolysis or by thermal hydrolysis. The hydrolysis leads to gelling or non-gelling grades.

The label states the gel strength (Bloom value) for the gelling grade, and that it is a non-gelling grade for the non-gelling grade.

◆**Description** Gelatin occurs as colorless or white to light yellow-brown sheets, shreds, granules or powder.

It is freely soluble in hot water, and practically insoluble in ethanol (95).

The gelling grade does not dissolve in water, but slowly swells and softens when immersed in it, gradually absorbing water 5 to 10 times its own mass.

The gelling grade derived from an acid-treated collagen exhibits an isoelectric point between pH 7.0 and 9.0, and the gelling grade derived from an alkali-treated collagen exhibits an isoelectric point between pH 4.5 and 5.0.

The non-gelling grade is freely soluble in water.◆

Identification (1) Dissolve 1.00 g of Gelatin in freshly boiled and cooled water at about 55°C to make 100 mL, and use this solution as the sample solution. To 2 mL of the sample solution keeping at about 55°C add 0.05 mL of copper (II) sulfate TS. Mix and add 0.5 mL of 2 mol/L sodium hydroxide TS: a violet color is produced.

(2) In a test tube about 15 mm in internal diameter, place

0.5 g of Gelatin, add 10 mL of water, and allow to stand for 10 minutes. Heat at 60°C for 15 minutes, then keep the tube upright at 2 to 8°C for 6 hours, and invert the tube: the contents do not flow out immediately for the gelling grade. In case of the non-gelling grade the contents flow out immediately.

(3) Apply to the non-gelling grade. Place 0.5 g of Gelatin in a 250-mL flask and add 10 mL of water and 5 mL of sulfuric acid. Cover with a watch glass or other instrument, avoiding complete closure, and heat at 105°C for 4 hours. Cool, add 200 mL of water, and then adjust to pH 6.0 to 8.0 with a sodium hydroxide solution (1 in 5). In a test tube, place 2 mL of this solution, add 2 mL of the oxidizing reagent, shake, and allow to stand for 20 minutes. Add 2 mL of the colored solution, shake, and warm in a water bath of 60°C for about 15 minutes: a red to purple color develops.

Oxidizing reagent: Dissolve 5.53 g of disodium hydrogen phosphate dodecahydrate and 0.48 g of citric acid monohydrate in water to make 100 mL. Dissolve 1.4 g of sodium toluenesulfonchloramide trihydrate in this solution. Prepare before use.

Colored solution: Dissolve 1.0 g of 4-dimethylaminobenzaldehyde in 3.5 mL of a solution of perchloric acid (1 in 2) and add slowly 6.5 mL of 2-propanol. Prepare before use.

Gel strength (Bloom value) Apply to the gelling grade. Determine the mass (g) necessary to produce the force which, applied to a plunger 12.7 mm in diameter, makes a depression 4 mm deep in a gel having a concentration of 6.67% and matured at 10°C.

(i) Apparatus: Texture analyzer or gelometer with a cylindrical piston 12.7 ± 0.1 mm in diameter with a plane pressure surface and a sharp bottom edge, and with a bottle 59 ± 1 mm in internal diameter and 85 mm high (jelly cup).

(ii) Procedure: Place 7.5 g of Gelatin in a jelly cup, add 105 mL of water, close the cup, and allow to stand for 1 to 4 hours. Heat in a water bath at $65 \pm 2^\circ\text{C}$ for 15 minutes. While heating, stir gently with a glass rod. Ensure that the solution is uniform and any condensed water on the inner walls of the cup is incorporated. Allow to cool at room temperature for 15 minutes and transfer the cup to a thermostatically controlled bath at $10.0 \pm 0.1^\circ\text{C}$, and fitted with a device to ensure that the platform on which the cup stands is perfectly horizontal. Close the cup, and allow to stand for 17 ± 1 hours. Remove the sample cup from the bath and quickly wipe the water from the exterior of the cup. Center the cup on the platform of the apparatus so that the plunger contacts the sample as nearly as its midpoint as possible, and start the measurement with 4 mm depression distance and 0.5 mm per second test speed: 80 to 120% of the labeled nominal value.

pH <2.54> pH at 55°C of the sample solution obtained in Identification (1) is 3.8 – 7.6.

Purity ◇(1) Heavy metals <1.07>—Proceed with 0.5 g of Gelatin according to Method 2, and perform the test. Prepare the control solution with 2.5 mL of Standard Lead Solution (not more than 50 ppm).◇

(2) Iron—To 5.00 g of Gelatin, in a glass-stoppered flask, add 10 mL of hydrochloric acid, close the flask, and heat in a water bath at 75 – 80°C for 2 hours. If necessary for proper solubilization, the gelatin may be allowed to swell after addition of the acid and before heating, the heating time may be prolonged and a higher temperature may be used. After cooling, adjust the content of the flask to 100.0 g with water, and use this solution as the sample solution. Separately, place 5.00 g each of Gelatin in three glass-stop-

pered flasks, proceed with them in the same manner as the sample solution, then add 10 mL, 20 mL and 30 mL of Standard Iron Solution (2) for Atomic Absorption Spectrophotometry exactly to each flask separately. Adjust the content of these flasks to 100.0 g each with water, and use these solutions as the standard solutions. The amount of the standard solution to be added may be adjusted according to the sensitivity of the instrument to be used. Perform the test with the sample solution and standard solutions as directed in the standard addition method under Atomic Absorption Spectrophotometry <2.23> according to the following conditions, and determine the content of iron: not more than 30 ppm.

Gas: Combustible gas—Acetylene.

Supporting gas—Air.

Lamp: Iron hollow cathode lamp.

Wavelength: 248.3 nm.

(3) Chromium—Use the sample solution obtained in (2) as the sample solution. Separately, place 5.00 g each of Gelatin in three glass-stoppered flasks, proceed with them in the same manner as the sample solution, then add 0.25 mL, 0.50 mL and 0.75 mL of Standard Chromium Solution for Atomic Absorption Spectrophotometry exactly to each flask separately. Adjust the content of these flasks to 100.0 g each with water, and use these solutions as the standard solutions. The amount of the standard solution to be added may be adjusted according to the sensitivity of the instrument to be used. Perform the test with the sample solution and standard solutions as directed in the standard addition method under Atomic Absorption Spectrophotometry <2.23> according to the following conditions, and determine the content of chromium: not more than 10 ppm.

Gas: Combustible gas—Acetylene.

Supporting gas—Air.

Lamp: Chromium hollow cathode lamp.

Wavelength: 357.9 nm.

(4) Zinc—Use the sample solution obtained in (2) as the sample solution. Separately, place 5.00 g each of Gelatin in three glass-stoppered flasks, proceed with them in the same manner as the sample solution, then add 7.5 mL, 15 mL and 22.5 mL of Standard Zinc Solution for Atomic Absorption Spectrophotometry exactly to each flask separately. Adjust the content of these flasks to 100.0 g each with water, and use these solutions as the standard solutions. The amount of the standard solution to be added may be adjusted according to the sensitivity of the instrument to be used. Perform the test with the sample solution and standard solutions as directed in the standard addition method under Atomic Absorption Spectrophotometry <2.23> according to the following conditions, and determine the content of zinc: not more than 30 ppm.

Gas: Combustible gas—Acetylene.

Supporting gas—Air.

Lamp: Zinc hollow cathode lamp.

Wavelength: 213.9 nm.

◇(5) Arsenic <1.11>—Take 15.0 g of Gelatin in a flask, add 60 mL of diluted hydrochloric acid (1 in 5), and dissolve by heating. Add 15 mL of bromine TS, heat until the excess of bromine is expelled, neutralize with ammonia TS, add 1.5 g of disodium hydrogen phosphate dodecahydrate, and allow to cool. To this solution add 30 mL of magnesia TS, allow to stand for 1 hour, and collect the precipitates. Wash the precipitates with five 10-mL portions of diluted ammonia TS (1 in 4), and dissolve in diluted hydrochloric acid (1 in 4) to make exactly 50 mL. Perform the test with 5 mL of this solution: the solution has no more color than the following color standard.

Color standard: Proceed with 15 mL of Standard Arsenic

Solution, instead of Gelatin, in the same manner (not more than 1 ppm).◇

(6) Peroxides—

(i) Enzyme reaction: Peroxidase transfers oxygen from peroxides to an organic redox indicator which is converted to a blue oxidation product. The intensity of the color obtained is proportional to the quantity of peroxide and can be compared with a color scale provided with the test strips, to determine the peroxide concentration.

(ii) Procedure: Weigh 20.0 ± 0.1 g of Gelatin in a beaker, add 80.0 ± 0.2 mL of water, and stir to moisten all the gelatin. Allow to stand at room temperature for 1–3 hours. Cover the beaker with a watch-glass, and heat the beaker for 20 ± 5 minutes in a water bath at $65 \pm 2^\circ\text{C}$ for dissolving the sample. Stir the contents of the beaker with a glass rod to achieve a homogeneous solution, and use this as the sample solution. Dip a peroxide test strip for 1 second into the sample solution, such that the reaction zone is properly wetted. Remove the test strip, shake off excess liquid, and compare the reaction zone after 15 seconds with the color scale provided. Multiply the concentration read from the color scale by a factor of 5 to calculate the concentration of peroxide in the test substance: not more than 10 ppm.

(iii) Suitability test: To exactly 10 mL of Standard Hydrogen Peroxide Solution add water to make exactly 300 mL. Pipet 2 mL of this solution, add water to make exactly 1000 mL (2 ppm). Dip a peroxide test strip for 1 second into this solution, such that the reaction zone is properly wetted. Remove the test strip, shake off excess liquid and compare the color of the reaction zone after 15 seconds with the color scale: the color of the zone is equivalent to 2 ppm of the color scale.

(7) Sulfur dioxide—

(i) Apparatus: Use as shown in the figure.

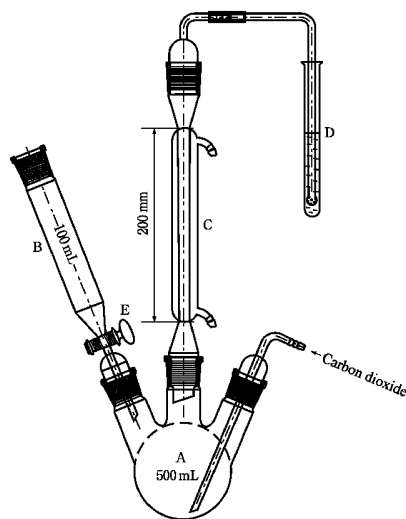

- A: Three-necked round-bottomed flask (500 mL)
 B: Cylindrical dropping funnel (100 mL)
 C: Condenser
 D: Test tube
 E: Tap

(ii) Procedure: Introduce 150 mL of water into the three-necked round-bottomed flask and pass carbon dioxide through the whole system at a rate of 100 mL per minute. Place 10 mL of hydrogen peroxide-sodium hydroxide TS in the test tube. After 15 minutes, remove the cylindrical dropping funnel without interrupting the stream of carbon dioxide, and introduce through the opening into the three-necked round-bottomed flask about 25.0 g of Gelatin with

the aid of 100 mL of water. Pour 80 mL of 2 mol/L hydrochloric acid TS into the funnel, open the tap to introduce the hydrochloric acid into the three-necked round-bottomed flask ◇ and close the tap while several mL of the hydrochloric acid remains, in order to avoid losing sulfur dioxide◇, and boil the mixture for 1 hour. Transfer the contents of the test tube with the aid of a little water to a 200 mL wide-necked conical flask. Heat the flask in a water bath for 15 minutes and cool. Add 0.1 mL of bromophenol blue TS and titrate <2.50> with 0.1 mol/L sodium hydroxide VS until the color changes from yellow to violet-blue lasting for at least 20 seconds. Perform a blank determination in the same manner, and make any necessary correction. Calculate the amount of sulfur dioxide from the following expression: it is not more than 50 ppm.

$$\text{Amount (ppm) of sulfur dioxide} = V/M \times 1000 \times 3.203$$

M: Amount (g) of Gelatin taken

V: Amount (mL) of 0.1 mol/L sodium hydroxide VS consumed

Conductivity <2.51> Perform the test at $30 \pm 1.0^\circ\text{C}$ with the sample solution obtained in Identification (1), without temperature compensation: not more than $1 \text{ mS} \cdot \text{cm}^{-1}$.

Loss on drying <2.41> Not more than 15.0% (5 g, 105°C , 16 hours).

Microbial limit <4.05> The acceptance criteria of TAMC and TYMC are 10^3 CFU/g and 10^2 CFU/g, respectively. *Escherichia coli* and *Salmonella* are not observed.

Containers and storage ◇Containers—Tight containers.◇
 Storage—Protect from heat and moisture.

Purified Gelatin

精製ゼラチン

Purified Gelatin is a purified protein obtained from collagen of animals by partial alkaline and/or acid hydrolysis, and/or enzymatic hydrolysis, or by thermal hydrolysis. The hydrolysis leads to gelling or non-gelling grades.

The label states the gel strength (Bloom value) for the gelling grade, and that it is a non-gelling grade for the non-gelling grade.

Description Purified Gelatin occurs as colorless or white to light yellow-brown sheets, shreds, granules or powder.

It is very soluble in hot water, and practically insoluble in ethanol (95).

The gelling grade does not dissolve in water. It slowly swells and softens when immersed in water, and absorbs water 5 to 10 times its own mass. The non-gelling grade is freely soluble in water.

Identification (1) To 5 mL of a solution of Purified Gelatin (1 in 100) add 2,4,6-trinitrophenol TS dropwise: a precipitate is formed.

(2) To 5 mL of a solution of Purified Gelatin (1 in 5000) add tannic acid TS dropwise: the solution becomes turbid.

(3) In a test tube about 15 mm in internal diameter, place 0.5 g of Purified Gelatin, add 10 mL of water, and allow to stand for 10 minutes. Heat at 60°C for 15 minutes, then keep the tube upright at 2 to 8°C for 6 hours, and invert the tube: the contents do not flow out immediately for the gelling grade. In case of the non-gelling grade the contents flow

out immediately.

Gel strength (Bloom value) Apply to the gelling grade. Determine the mass (g) necessary to produce the force which, applied to a plunger 12.7 mm in diameter, makes a depression 4 mm deep in the surface of the gel having a concentration of 6.67% and matured at 10°C.

(i) Apparatus, instruments: Texture analyzer or gelometer with a cylindrical piston 12.7 ± 0.1 mm in diameter with a plane bottom and a sharp bottom edge, and with a cup 59 ± 1 mm in internal diameter and 85 mm high (jelly cup).

(ii) Procedure: Place 7.5 g of Purified Gelatin in a jelly cup, add 105 mL of water, close the cup, and allow to stand for 1 to 4 hours. Heat in a water bath at $65 \pm 2^\circ\text{C}$ for 15 minutes. While heating, stir gently with a glass rod. Incorporate any condensed water on the inner wall of the cup into the solution, and ensure that the solution is uniform. Allow to cool at room temperature for 15 minutes and transfer the cup to a thermostatically controlled bath at $10.0 \pm 0.1^\circ\text{C}$, and fitted with a device to ensure that the platform on which the cup stands is perfectly horizontal. Close the cup, and allow to stand for 17 ± 1 hours. Remove the sample cup from the bath and quickly wipe the water from the exterior of the cup. Put the cup on the platform of the apparatus so that the tip of plunger contacts the sample as nearly as its midpoint as possible, and start the measurement with 4 mm depression distance and 0.5 mm per second test speed: 80 to 120% of the labeled nominal value.

pH <2.54> Dissolve 1.00 g of Purified Gelatin in freshly boiled water and kept at about 55°C , to make 100 mL. pH at 55°C of this solution is 3.8 – 9.0.

Purity (1) Heavy metals<1.07>—Proceed with 1.0 g of Purified Gelatin according to Method 2, and perform the test. Prepare the control solution with 2.0 mL of Standard Lead Solution (not more than 20 ppm).

(2) Iron—To 5.00 g of Purified Gelatin, in a glass-stoppered flask, add 10 mL of hydrochloric acid, close the flask, and place in a water bath at $75 - 80^\circ\text{C}$ for 2 hours. If necessary for proper solubilization, the gelatin may be allowed to swell after addition of the acid and the heating time may be prolonged or a higher temperature may be used. After cooling, adjust the content of the flask to 100.0 g with water, and use this solution as the sample solution. Separately, place 5.00 g each of Purified Gelatin in three glass-stoppered flasks, proceed with them in the same manner as the sample solution, then add exactly 10 mL, 20 mL and 30 mL of Standard Iron Solution (2) for Atomic Absorption Spectrophotometry to each flask, respectively. Adjust the content of these flasks to 100.0 g each with water, and use these solutions as the standard solutions. The volume of Standard Iron Solution may be adjusted appropriately according to the sensitivity of the instrument to be used. Perform the test with the sample solution and standard solutions as directed in the standard addition method under Atomic Absorption Spectrophotometry<2.23> according to the following conditions, and determine the content of iron: not more than 30 ppm.

Gas: Combustible gas—Acetylene.

Supporting gas—Air.

Lamp: Iron hollow cathode lamp.

Wavelength: 248.3 nm.

(3) Chromium—Use the sample solution obtained in (2) as the sample solution. Separately, place 5.00 g each of Purified Gelatin in three glass-stoppered flasks, proceed with them in the same manner as the sample solution, then add exactly 0.25 mL, 0.50 mL and 0.75 mL of Standard Chromi-

um Solution for Atomic Absorption Spectrophotometry to each flask, respectively. Adjust the content of these flasks to 100.0 g each with water, and use these solutions as the standard solutions. The volume of Standard Iron Solution may be adjusted appropriately according to the sensitivity of the instrument to be used. Perform the test with the sample solution and standard solutions as directed in the standard addition method under Atomic Absorption Spectrophotometry <2.23> according to the following conditions, and determine the content of chromium: not more than 10 ppm.

Gas: Combustible gas—Acetylene.

Supporting gas—Air.

Lamp: Chromium hollow cathode lamp.

Wavelength: 357.9 nm.

(4) Zinc—Use the sample solution obtained in (2) as the sample solution. Separately, place 5.00 g each of Purified Gelatin in three glass-stoppered flasks, proceed with them in the same manner as the sample solution, then add exactly 7.5 mL, 15 mL and 22.5 mL of Standard Zinc Solution for Atomic Absorption Spectrophotometry to each flask, respectively. Adjust the content of these flasks to 100.0 g each with water, and use these solutions as the standard solutions. The volume of Standard Iron Solution may be adjusted appropriately according to the sensitivity of the instrument to be used. Perform the test with the sample solution and standard solutions as directed in the standard addition method under Atomic Absorption Spectrophotometry <2.23> according to the following conditions, and determine the content of zinc: not more than 30 ppm.

Gas: Combustible gas—Acetylene.

Supporting gas—Air.

Lamp: Zinc hollow cathode lamp.

Wavelength: 213.9 nm.

(5) Arsenic<1.11>—Place 15.0 g of Purified Gelatin in a flask, add 60 mL of diluted hydrochloric acid (1 in 5), and dissolve by heating. Add 15 mL of bromine TS, heat until the excess of bromine is expelled, neutralize with ammonia TS, add 1.5 g of disodium hydrogen phosphate dodecahydrate, and allow to cool. To this solution add 30 mL of magnesia TS, allow to stand for 1 hour, and collect the precipitates. Wash the precipitates with five 10-mL portions of diluted ammonia TS (1 in 4), and dissolve in diluted hydrochloric acid (1 in 4) to make exactly 50 mL. Perform the test with 5 mL of this solution: the solution has no more color than the following color standard.

Color Standard: Proceed with 12 mL of Standard Arsenic Solution, instead of Purified Gelatin, in the same manner (not more than 0.8 ppm).

(6) Peroxides—

(i) Enzyme reaction: Peroxidase transfers oxygen atom at on from peroxides to an organic redox indicator which is converted to a blue oxidized form. The intensity of the color obtained is proportional to the quantity of peroxide. The peroxide concentration can be determined by comparing it with the color scale provided with the test strips employing this reaction.

(ii) Procedure: Weigh 20.0 ± 0.1 g of Purified Gelatin in a beaker, add 80.0 ± 0.2 mL of water, and stir to moisten all the gelatin. Allow to stand at room temperature for 1–3 hours. Cover the beaker with a watch-glass, and heat the beaker for 20 ± 5 minutes in a water bath at $65 \pm 2^\circ\text{C}$ to dissolve the sample. Stir the contents of the beaker with a glass rod to achieve a homogeneous solution, and use this as the sample solution. Dip a peroxide test strip for 1 second into the sample solution, such that the reaction zone is properly wetted. Remove the test strip, shake off excess liquid, and compare the reaction zone after 15 seconds with the

color scale provided. Multiply the concentration read from the color scale by a factor of 5 to calculate the concentration of peroxide in the test substance: not more than 10 ppm.

(iii) Sensitivity: To exactly 10 mL of Standard Hydrogen Peroxide Solution add water to make exactly 300 mL. Pipet exactly 2 mL of this solution, add water to make exactly 1000 mL (2 ppm). Dip a peroxide test strip for 1 second into this solution, such that the reaction zone is properly wetted. Remove the test strip, shake off excess liquid and compare the color of the reaction zone after 15 seconds with the color scale: the color of the zone is equivalent to 2 ppm of the color scale.

(7) Sulfur dioxide—

(i) Apparatus: Use as shown in the figure.

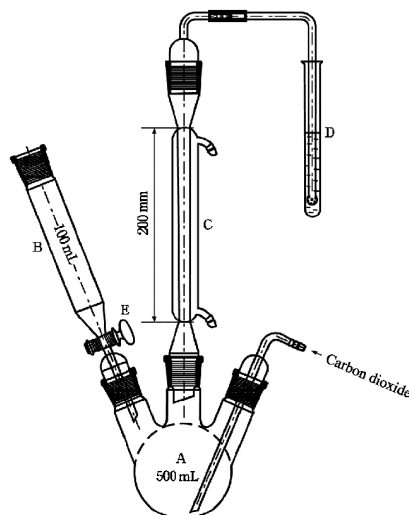

A: Three-necked round-bottomed flask (500 mL)

B: Cylindrical dropping funnel (100 mL)

C: Condenser

D: Test tube

E: Tap

(ii) Procedure: Introduce 150 mL of water into the three-necked round-bottomed flask and pass carbon dioxide through the whole system at a rate of 100 mL per minute. Place 10 mL of hydrogen peroxide-sodium hydroxide TS in the test tube. After 15 minutes, remove the cylindrical dropping funnel from the flask without interrupting the stream of carbon dioxide, and introduce through the opening into the flask about 25.0 g of Purified Gelatin with the aid of 100 mL of water. Pour 80 mL of 2 mol/L hydrochloric acid TS into the funnel, open the tap to introduce the hydrochloric acid into the flask and close the tap while several mL of the hydrochloric acid remains, in order to avoid losing sulfur dioxide, and boil the mixture for 1 hour. Remove the test tube, and transfer the contents of the test tube to a 200-mL wide-necked conical flask, wash the test tube with a small amount of water, and add the washing to the conical flask. Heat the flask in a water bath for 15 minutes and cool. Add 0.1 mL of bromophenol blue TS, and titrate <2.50> with 0.1 mol/L sodium hydroxide VS until the color changes from yellow to violet-blue lasting for at least 20 seconds. Perform a blank determination in the same manner and make any necessary correction. Calculate the amount of sulfur dioxide from the following expression: it is not more than 20 ppm.

$$\text{Amount (ppm) of sulfur dioxide} = V/M \times 1000 \times 3.203$$

M: Amount (g) of Purified Gelatin taken

V: Amount (mL) of 0.1 mol/L sodium hydroxide VS consumed

Conductivity <2.51> Dissolve 1.00 g of Purified Gelatin in freshly boiled water and kept at about 55°C, to make 100 mL. Perform the test at 30 ± 1.0°C with this solution, without temperature compensation: not more than 1 mS·cm⁻¹.

Loss on drying <2.41> Not more than 15.0% (5 g, 105°C, 16 hours).

Microbial limit <4.05> The acceptance criteria of TAMC and TYMC are 10³ CFU/g and 10² CFU/g, respectively. *Escherichia coli* and *Salmonella* are not observed.

Containers and storage Containers—Tight containers.

Storage—Protect from heat and moisture.

Gentamicin Sulfate

ゲンタマイシン硫酸塩

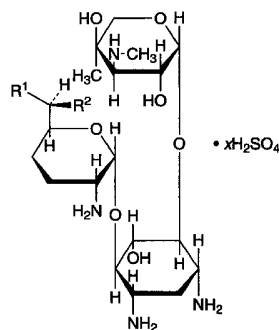

Gentamicin C₁ Sulfate : R¹ = CH₃ R² = NHCH₃

Gentamicin C₂ Sulfate : R¹ = CH₃ R² = NH₂

Gentamicin C_{1a} Sulfate : R¹ = H R² = NH₂

Gentamicin C₁ Sulfate

(6*R*)-2-Amino-2,3,4,6-tetra-deoxy-6-methylamino-6-methyl-α-D-erythro-hexopyranosyl-(1→4)-[3-deoxy-4-*C*-methyl-3-methylamino-β-L-arabinopyranosyl-(1→6)]-2-deoxy-D-streptamine sulfate

Gentamicin C₂ Sulfate

(6*R*)-2,6-Diamino-2,3,4,6-tetra-deoxy-6-methyl-α-D-erythro-hexopyranosyl-(1→4)-[3-deoxy-4-*C*-methyl-3-methylamino-β-L-arabinopyranosyl-(1→6)]-2-deoxy-D-streptamine sulfate

Gentamicin C_{1a} Sulfate

2,6-Diamino-2,3,4,6-tetra-deoxy-α-D-erythro-hexopyranosyl-(1→4)-[3-deoxy-4-*C*-methyl-3-methylamino-β-L-arabinopyranosyl-(1→6)]-2-deoxy-D-streptamine sulfate

[1405-41-0, Gentamicin Sulfate]

Gentamicin Sulfate is the sulfate of a mixture of aminoglycoside substances having antibacterial activity produced by the growth of *Micromonospora purpurea* or *Micromonospora echinospora*.

It contains not less than 590 μg (potency) and not more than 775 μg (potency) per mg, calculated on the dried basis. The potency of Gentamicin Sulfate is expressed as mass (potency) of gentamicin C₁ (C₂₁H₄₃N₅O₇: 477.60).

Description Gentamicin Sulfate occurs as a white to light yellow-white powder.

It is very soluble in water, and practically insoluble in ethanol (99.5).

It is hygroscopic.

Identification (1) Dissolve 50 mg each of Gentamicin Sul-

fate and Gentamicin Sulfate RS in 10 mL of water, and use these solutions as the sample solution and standard solution. Perform the test with these solutions as directed under Thin-layer Chromatography <2.03>. Spot 20 μ L of the sample solution and standard solution on a plate of silica gel for thin-layer chromatography. Separately, shake a mixture of chloroform, ammonia solution (28) and methanol (2:1:1) in a separator, and allow the mixture to stand for more than 1 hour. To 20 mL of the lower layer so obtained add 0.5 mL of methanol, and use this as the developing solvent. Develop the plate with the developing solvent to a distance of about 17 cm in a developing container with a cover, having an opening of about 20 mm², and without putting a filter paper in the container, and air-dry the plate. Allow the plate to stand in iodine vapors: three principal spots obtained from the sample solution are the same with the corresponding spots from the standard solution in color tone and the *R_f* value, respectively.

(2) Dissolve 50 mg of Gentamicin Sulfate in 5 mL of water, and add 0.5 mL of barium chloride TS: a white precipitate is formed.

Optical rotation <2.49> $[\alpha]_D^{25}$: +107 – +121° (0.25 g calculated on the dried basis, water, 25 mL, 100 mm).

pH <2.54> The pH of a solution obtained by dissolving 0.20 g of Gentamicin Sulfate in 5 mL of water is between 3.5 and 5.5.

Content ratio of the active principle Dissolve 50 mg of Gentamicin Sulfate in water to make 10 mL, and use this solution as the sample solution. Perform the test with the sample solution as directed under Thin-layer Chromatography <2.03>. Spot 20 μ L of the sample solution on a plate of silica gel for thin-layer chromatography. Separately, shake a mixture of chloroform, ammonia solution (28) and methanol (2:1:1) in a separator, and allow the mixture to stand for more than 1 hour. To 20 mL of the lower layer so obtained add 0.5 mL of methanol, and use this as the developing solvent. Develop the plate with the developing solvent to a distance of about 17 cm in a developing container with a cover, having an opening of about 20 mm², without putting a filter paper in the container, and air-dry the plate. Allow the plate to stand in iodine vapor. Determine the integral absorbances, *A_a*, *A_b* and *A_c*, of the colored spots of gentamicin *C₁* (*R_f* value: about 0.3), gentamicin *C₂* (*R_f* value: about 0.2) and gentamicin *C_{1a}* (*R_f* value: about 0.1), respectively, by a densitometer (wavelength: 450 nm) while covering the plate with a glass plate, and calculate these amounts by the following formulae: gentamicin *C₁* is between 25% and 55%, gentamicin *C₂* is between 25% and 50%, and gentamicin *C_{1a}* is between 5% and 30%.

$$\begin{aligned} \text{Amount (\%)} \text{ of gentamicin } C_1 \\ = A_a / (A_a + 1.35A_b + A_c) \times 100 \end{aligned}$$

$$\begin{aligned} \text{Amount (\%)} \text{ of gentamicin } C_2 \\ = 1.35A_b / (A_a + 1.35A_b + A_c) \times 100 \end{aligned}$$

$$\begin{aligned} \text{Amount (\%)} \text{ of gentamicin } C_{1a} \\ = A_c / (A_a + 1.35A_b + A_c) \times 100 \end{aligned}$$

Purity (1) Clarity and color of solution—Dissolve 1.0 g of Gentamicin Sulfate in 10 mL of water: the solution is clear and its absorbance at 400 nm determined as directed under Ultraviolet-visible Spectrophotometry <2.24> is not more than 0.08.

(2) Heavy metals <1.07>—Proceed with 2.0 g of Gentamicin Sulfate according to Method 4, and perform the test. Prepare the control solution with 2.0 mL of Standard Lead

Solution (not more than 10 ppm).

(3) Related substances—Dissolve 50 mg of Gentamicin Sulfate in 10 mL of water, and use this solution as the sample solution. Pipet 1 mL of the sample solution, add water to make exactly 50 mL, and use this solution as the standard solution. Perform the test with these solutions as directed under Thin-layer Chromatography <2.03>. Spot 20 μ L of the sample solution and standard solution on a plate of silica gel for thin-layer chromatography. Separately, shake a mixture of chloroform, ammonia solution (28) and methanol (2:1:1) in a separator, and allow the mixture to stand for more than 1 hour. To 20 mL of the lower layer so obtained add 0.5 mL of methanol, and use this as the developing solvent. Develop the plate with the developing solvent to a distance of about 17 cm in a developing container with a cover, having an opening of about 20 mm², without putting a filter paper in the container, and air-dry the plate. Allow the plate to stand in iodine vapor, and compare the colored spots while covering with a glass plate: the spots other than the spots of gentamicin *C₁* (*R_f* value: about 0.3), gentamicin *C₂* (*R_f* value: about 0.2) and gentamicin *C_{1a}* (*R_f* value: about 0.1) obtained from the sample solution are not more intense than the spot of gentamicin *C₂* from the standard solution.

Loss on drying <2.41> Not more than 18.0% (0.15 g, reduced pressure not exceeding 0.67 kPa, 110°C, 3 hours). Handle the sample avoiding absorption of moisture.

Residue on ignition <2.44> Not more than 1.0% (1 g).

Assay Perform the test according to the Cylinder-plate method as directed under Microbial Assay for Antibiotics <4.02> according to the following conditions.

(i) Test organism—*Staphylococcus epidermidis* ATCC 12228

(ii) Agar media for seed and base layer—	
Glucose	1.0 g
Peptone	6.0 g
Meat extract	1.5 g
Yeast extract	3.0 g
Sodium chloride	10.0 g
Agar	15.0 g
Water	1000 mL

Mix all the ingredients, and sterilize. Adjust the pH of the solution so that it will be 7.8 to 8.0 after sterilization.

(iii) Agar medium for transferring test organisms—Use the medium ii in 2) Medium for other organisms under (2) Agar media for transferring test organisms.

(iv) Standard solutions—Weigh accurately an amount of Gentamicin Sulfate RS, equivalent to about 25 mg (potency), dissolve in 0.1 mol/L phosphate buffer solution (pH 8.0) to make exactly 25 mL, and use this solution as the standard stock solution. Keep the standard stock solution at 15°C or lower, and use within 30 days. Take exactly a suitable amount of the standard stock solution before use, add 0.1 mol/L phosphate buffer solution (pH 8.0) to make solutions so that each mL contains 4 μ g (potency) and 1 μ g (potency), and use these solutions as the high concentration standard solution and the low concentration standard solution, respectively.

(v) Sample solutions—Weigh accurately an amount of Gentamicin Sulfate, equivalent to about 25 mg (potency), and dissolve in 0.1 mol/L phosphate buffer solution (pH 8.0) to make exactly 25 mL. Take exactly a suitable amount of this solution, add 0.1 mol/L phosphate buffer solution (pH 8.0) to make solutions so that each mL contains 4 μ g (potency) and 1 μ g (potency), and use these solutions as the high concentration sample solution and the low concentra-

tion sample solution, respectively.

Containers and storage Containers—Tight containers.

Gentamicin Sulfate Injection

ゲンタマイシン硫酸塩注射液

Gentamicin Sulfate Injection is an aqueous injection.

It contains not less than 90.0% and not more than 110.0% of the labeled potency of gentamicin C₁ (C₂₁H₄₃N₅O₇; 477.60).

Method of preparation Prepare as directed under Injections, with Gentamicin Sulfate.

Description Gentamicin Sulfate Injection is a clear and colorless liquid.

Identification To a volume of Gentamicin Sulfate Injection, equivalent to 40 mg (potency) of Gentamicin Sulfate, add water to make 10 mL, and use this solution as the sample solution. Separately, dissolve an amount of Gentamicin Sulfate RS, equivalent to 20 mg (potency), in 5 mL of water, and use this solution as the standard solution. Perform the test with these solutions as directed under Thin-layer Chromatography <2.03>. Spot 5 μ L each of the sample solution and standard solution on a plate of silica gel for thin-layer chromatography. Develop the plate with the lower layer of a mixture of chloroform, ammonia solution (28) and methanol (2:1:1) to a distance of about 15 cm, and air-dry the plate. Spray evenly 0.2% ninhydrin-water saturated 1-butanol TS on the plate, and heat the plate at 100°C for 10 minutes: three principal spots obtained from the sample solution are the same with the corresponding spots from the standard solution in color tone and the R_f value, respectively.

Osmotic pressure ratio Being specified separately when the drug is granted approval based on the Law.

pH <2.54> 4.0 – 6.0

Bacterial endotoxins <4.01> Less than 0.50 EU/mg (potency).

Extractable volume <6.05> It meets the requirement.

Foreign insoluble matter <6.06> Perform the test according to Method 1: it meets the requirement.

Insoluble particulate matter <6.07> It meets the requirement.

Sterility <4.06> Perform the test according to the Membrane filtration method: it meets the requirement.

Assay Perform the test according to the Cylinder-plate method as directed under Microbial Assay for Antibiotics <4.02> according to the following conditions.

(i) Test organism, agar media for base and seed layer, agar medium for transferring test organisms, and standard solutions—Proceed as directed in the Assay under Gentamicin Sulfate.

(ii) Sample solutions—Pipet a volume of Gentamicin Sulfate Injection, equivalent to about 40 mg (potency) of Gentamicin Sulfate, add 0.1 mol/L phosphate buffer solution (pH 8.0) to make exactly 200 mL. Pipet a suitable volume of this solution, add 0.1 mol/L phosphate buffer solution (pH 8.0) to make solutions so that each mL contains 4 μ g (potency) and 1 μ g (potency), and use these solutions as

the high concentration sample solution and the low concentration sample solution, respectively.

Containers and storage Containers—Hermetic containers.

Gentamicin Sulfate Ointment

ゲンタマイシン硫酸塩軟膏

Gentamicin Sulfate Ointment contains not less than 90.0% and not more than 110.0% of the labeled potency of gentamicin C₁ (C₂₁H₄₃N₅O₇; 477.60).

Method of preparation Prepare as directed under Ointments, with Gentamicin Sulfate.

Identification To an amount of Gentamicin Sulfate Ointment, equivalent to 5 mg (potency) of Gentamicin Sulfate, add 10 mL of diethyl ether, and shake in lukewarm water, if necessary, to dissolve. Add 5 mL of water, shake for 10 minutes, centrifuge, and use the water layer as the sample solution. Separately, dissolve an amount of Gentamicin Sulfate RS, equivalent to 10 mg (potency), in 10 mL of water, and use this solution as the standard solution. Perform the test with these solutions as directed under Thin-layer Chromatography <2.03>. Spot 10 μ L each of the sample solution and standard solution on a plate of silica gel for thin-layer chromatography. Develop the plate with the lower layer of a mixture of chloroform, ammonia solution (28) and methanol (2:1:1) to a distance of about 15 cm, and air-dry the plate. Spray evenly 0.2% ninhydrin-water saturated 1-butanol TS on the plate, and heat the plate at 100°C for 10 minutes: three principal spots obtained from the sample solution are the same with the corresponding spots from the standard solution in color tone and the R_f value, respectively.

Assay Perform the test according to the Cylinder-plate method as directed under Microbial Assay for Antibiotics <4.02> according to the following conditions.

(i) Test organism, agar media for base and seed layer, agar medium for transferring test organisms, and standard solutions—Proceed as directed in the Assay under Gentamicin Sulfate.

(ii) Sample solutions—Weigh accurately an amount of Gentamicin Sulfate Ointment, equivalent to about 1 mg (potency) of Gentamicin Sulfate, transfer to a separator, add 50 mL of diethyl ether, and shake until the solution becomes uniform. Add 25 mL of 0.1 mol/L phosphate buffer solution (pH 8.0), shake, and collect the water layer. Repeat the same procedure with 25 mL of 0.1 mol/L phosphate buffer solution (pH 8.0), and combine the water layers. To this solution add 0.1 mol/L phosphate buffer solution (pH 8.0) to make exactly 100 mL. Pipet a suitable volume of this solution, add 0.1 mol/L phosphate buffer solution (pH 8.0) to make solutions so that each mL contains 4 μ g (potency) and 1 μ g (potency), and use these solutions as the high concentration sample solution and the low concentration sample solution, respectively.

Containers and storage Containers—Tight containers.

Gentamicin Sulfate Ophthalmic Solution

ゲンタマイシン硫酸塩点眼液

Gentamicin Sulfate Ophthalmic Solution is an aqueous ophthalmic preparation.

It contains not less than 90.0% and not more than 110.0% of the labeled potency of expressed as mass of gentamicin C₁ (C₂₁H₄₃N₅O₇; 477.60).

Method of preparation Prepare as directed under Ophthalmic Liquids and Solutions, with Gentamicin Sulfate.

Description Gentamicin Sulfate Ophthalmic Solution is a clear, colorless or pale yellow liquid.

Identification To a volume of Gentamicin Sulfate Ophthalmic Solution, equivalent to 10 mg (potency) of Gentamicin Sulfate, add water to make 5 mL, and use this solution as the sample solution. Separately, dissolve an amount of Gentamicin Sulfate RS, equivalent to 10 mg (potency), in 5 mL of water, and use this solution as the standard solution. Perform the test with these solutions as directed under Thin-layer Chromatography <2.03>. Spot 5 μL each of the sample solution and standard solution on a plate of silica gel for thin-layer chromatography. Develop the plate with the lower layer of a mixture of chloroform, ammonia solution (28) and methanol (2:1:1) to a distance of about 15 cm, and air-dry the plate. Spray evenly 0.2% ninhydrin-water saturated 1-butanol TS on the plate, and heat the plate at 100°C for 5 minutes: three principal spots obtained from the sample solution are the same with the corresponding spots from the standard solution in color tone and the R_f value, respectively.

pH <2.54> 5.5 – 7.5

Foreign insoluble matter <6.11> It meets the requirement.

Insoluble particulate matter <6.08> It meets the requirement.

Sterility <4.06> Perform the test according to the Membrane filtration method: it meets the requirement.

Assay Perform the test according to the Cylinder-plate method as directed under Microbial Assay for Antibiotics <4.02> according to the following conditions.

(i) Test organism, agar media for seed and base layer, agar medium for transferring test organism, and standard solutions—Proceed as directed in the Assay under Gentamicin Sulfate.

(ii) Sample solutions—Pipet a volume of Gentamicin Sulfate Ophthalmic Solution, equivalent to about 12 mg (potency) of Gentamicin Sulfate, add 0.1 mol/L phosphate buffer solution (pH 8.0) to make a solution so that each mL contains about 1 mg (potency). Pipet a suitable volume of this solution, add 0.1 mol/L phosphate buffer solution (pH 8.0) to make solutions so that each mL contains 4 μg (potency) and 1 μg (potency), and use these solutions as the high concentration sample solution and the low concentration sample solution, respectively.

Containers and storage Containers—Tight containers.

Shelf life 24 months after preparation.

Glibenclamide

グリベンクラミド

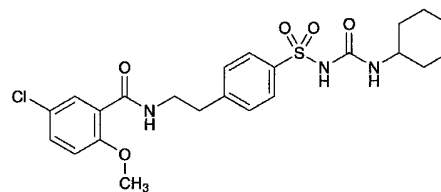

C₂₃H₂₈ClN₃O₅S: 494.00

4-[2-(5-Chloro-2-methoxybenzoylamino)ethyl]-N-(cyclohexylcarbamoyl)benzenesulfonamide
[10238-21-8]

Glibenclamide, when dried, contains not less than 98.5% of glibenclamide (C₂₃H₂₈ClN₃O₅S).

Description Glibenclamide occurs as white to pale yellowish white, crystals or crystalline powder.

It is freely soluble in dimethylformamide, sparingly soluble in chloroform, slightly soluble in methanol and in ethanol (95), and practically insoluble in water.

Identification (1) Determine the absorption spectrum of a solution of Glibenclamide in methanol (1 in 10,000) as directed under Ultraviolet-visible Spectrophotometry <2.24>, and compare the spectrum with the Reference Spectrum: both spectra exhibit similar intensities of absorption at the same wavelengths.

(2) Determine the infrared absorption spectrum of Glibenclamide, previously dried, as directed in the potassium bromide disk method under Infrared Spectrophotometry <2.25>, and compare the spectrum with the Reference Spectrum: both spectra exhibit similar intensities of absorption at the same wave numbers.

(3) Perform the test with Glibenclamide as directed under Flame Coloration Test <1.04> (2): a green color appears.

Melting point <2.60> 169 – 174°C

Purity (1) Heavy metals <1.07>—Proceed with 1.0 g of Glibenclamide according to Method 2, and perform the test. Prepare the control solution with 2.0 mL of Standard Lead Solution (not more than 20 ppm).

(2) Related substances—Dissolve 0.20 g of Glibenclamide in 20 mL of chloroform, and use this solution as the sample solution. Pipet 1 mL of the sample solution, and add chloroform to make exactly 20 mL. Pipet 1 mL of this solution, add chloroform to make exactly 10 mL, and use this solution as the standard solution. Perform the test with these solutions as directed under Thin-layer Chromatography <2.03>. Spot 10 μL each of the sample solution and standard solution on a plate of silica gel with fluorescent indicator for thin-layer chromatography. Develop the plate with a mixture of 1-propanol, chloroform and diluted ammonia TS (4 in 5) (11:7:2) to a distance of about 12 cm, and air-dry the plate. Examine under ultraviolet light (main wavelength: 254 nm): the spots other than the principal spot obtained from the sample solution are not more intense than the spot from the standard solution.

Loss on drying <2.41> Not more than 0.5% (1 g, 105°C, 4 hours).

Assay Weigh accurately about 0.9 g of Glibenclamide, previously dried, dissolve in 50 mL of *N,N*-dimethylformamide,

and titrate <2.50> with 0.1 mol/L sodium hydroxide VS (indicator: 3 drops of phenolphthalein TS). Perform a blank determination in the same manner with a solution prepared by adding 18 mL of water to 50 mL of *N,N*-dimethylformamide, and make any necessary correction.

Each mL of 0.1 mol/L sodium hydroxide VS
= 49.40 mg of C₂₃H₂₈ClN₃O₅S

Containers and storage Containers—Tight containers.

Gliclazide

グリクラジド

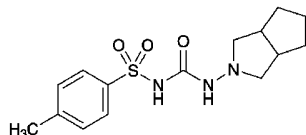

C₁₅H₂₁N₃O₃S: 323.41
1-(Hexahydrocyclopenta[*c*]pyrrol-2(1*H*)-yl)-
3-[(4-methylphenyl)sulfonyl]urea
[21187-98-4]

Gliclazide, when dried, contains not less than 98.5% and not more than 101.0% of gliclazide (C₁₅H₂₁N₃O₃S).

Description Gliclazide is a white crystalline powder.

It is sparingly soluble in acetonitrile and in methanol, slightly soluble in ethanol (99.5) and practically insoluble in water.

Identification (1) Determine the absorption spectrum of a solution of Gliclazide in methanol (1 in 62,500) as directed under Ultraviolet-visible Spectrophotometry <2.24>, and compare the spectrum with the Reference Spectrum: both spectra exhibit similar intensities of absorption at the same wavelengths.

(2) Determine the infrared absorption spectrum of Gliclazide, previously dried, as directed in the potassium bromide disk method under Infrared Spectrophotometry <2.25>, and compare the spectrum with the Reference Spectrum: both spectra exhibit similar intensities of absorption at the same wave numbers.

Melting point <2.60> 165 – 169°C

Purity (1) Heavy metals <1.07>—Proceed with 2.0 g of Gliclazide according to Method 2, and perform the test. Prepare the control solution with 2.0 mL of Standard Lead Solution (not more than 10 ppm).

(2) Related substances—Conduct this procedure within 2 hours after preparation of the sample solution. Dissolve 50 mg of Gliclazide in 23 mL of acetonitrile, add water to make 50 mL, and use this solution as the sample solution. Pipet 1 mL of the sample solution, and add a mixture of water and acetonitrile (11:9) to make exactly 100 mL. Pipet 10 mL of this solution, add a mixture of water and acetonitrile (11:9) to make exactly 100 mL, and use this solution as the standard solution. Perform the test with exactly 20 μL each of the sample solution and standard solution as directed under Liquid Chromatography <2.01> according to the following conditions. Determine each peak area of both solutions by the automatic integration method: the area of each peak other than gliclazide obtained from the sample solution is not larger than the peak area of gliclazide from the standard solution, and the total area of the peaks other than the peak of

gliclazide from the sample solution is not larger than 3 times the peak area of gliclazide from the standard solution. For the area of the peak, having the relative retention time of about 0.9 to gliclazide, multiply the correction factor 5.65.

Operating conditions—

Detector: An ultraviolet absorption photometer (wavelength: 235 nm).

Column: A stainless steel column 4.0 mm in inside diameter and 25 cm in length, packed with octylsilanized silica gel for liquid chromatography (4 μm in particle diameter).

Column temperature: A constant temperature of about 25°C.

Mobile phase: A mixture of water, acetonitrile, triethylamine and trifluoroacetic acid (550:450:1:1).

Flow rate: Adjust so that the retention time of gliclazide is about 14 minutes.

Time span of measurement: About 2 times as long as the retention time of gliclazide, beginning after the solvent peak.

System suitability—

Test for required detectability: Pipet 4 mL of the standard solution, and add a mixture of water and acetonitrile (11:9) to make exactly 20 mL. Confirm that the peak area of gliclazide obtained with 20 μL of this solution is equivalent to 10 to 30% of that of gliclazide with 20 μL of the standard solution.

System performance: When the procedure is run with 20 μL of the standard solution under the above operating conditions, the number of theoretical plates and the symmetry factor of the peak of gliclazide are not less than 8000 and not more than 1.5, respectively.

System repeatability: When the test is repeated 6 times with 20 μL of the standard solution under the above operating conditions, the relative standard deviation of the peak area of gliclazide is not more than 2.0%.

Loss on drying <2.41> Not more than 0.5% (1 g, 105°C, 2 hours).

Residue on ignition <2.44> Not more than 0.1% (1 g).

Assay Weigh accurately about 0.3 g of Gliclazide, previously dried, dissolve in 30 mL of a mixture of acetic anhydride and acetic acid (100) (7:3), and titrate <2.50> with 0.1 mol/L perchloric acid VS (potentiometric titration). Perform a blank determination in the same manner, and make any necessary correction.

Each mL of 0.1 mol/L perchloric acid VS
= 32.34 mg of C₁₅H₂₁N₃O₃S

Containers and storage Containers—Well-closed containers.

Glimepiride

グリメピリド

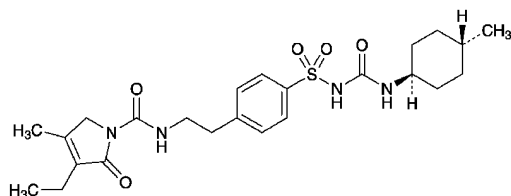

$C_{24}H_{34}N_4O_5S$: 490.62

1-(4-{2-[(3-Ethyl-4-methyl-2-oxo-3-pyrroline-1-carbonyl)amino]ethyl}phenylsulfonyl)-3-(*trans*-4-methylcyclohexyl)urea
[93479-97-1]

Glimepiride contains not less than 98.0% and not more than 102.0% of glimepiride ($C_{24}H_{34}N_4O_5S$), calculated on the anhydrous basis.

Description Glimepiride occurs as a white crystalline powder.

It is slightly soluble in dichloromethane, very slightly soluble in methanol and in ethanol (99.5), and practically insoluble in water.

Melting point: about 202°C (with decomposition).

Identification (1) Determine the absorption spectrum of a solution of Glimepiride in methanol (1 in 125,000) as directed under Ultraviolet-visible Spectrophotometry <2.24>, and compare the spectrum with the Reference Spectrum or the spectrum of a solution of Glimepiride RS prepared in the same manner as the sample solution: both spectra exhibit similar intensities of absorption at the same wavelengths.

(2) Determine the infrared absorption spectrum of Glimepiride as directed in the potassium bromide disk method under Infrared Spectrophotometry <2.25>, and compare the spectrum with the Reference Spectrum or the spectrum of Glimepiride RS: both spectra exhibit similar intensities of absorption at the same wave numbers.

Purity (1) Heavy metals <1.07>—Proceed with 2.0 g of Glimepiride according to Method 2, and perform the test. Prepare the control solution with 2.0 mL of Standard Lead Solution (not more than 10 ppm).

(2) *cis*-Isomer—Dissolve 10 mg of Glimepiride in 5 mL of dichloromethane, add the mobile phase to make 20 mL, and use this solution as the sample solution. Pipet 1 mL of the sample solution, add the mobile phase to make exactly 100 mL, and use this solution as the standard solution. Perform the test with exactly 10 μL each of the sample solution and standard solution as directed under Liquid Chromatography <2.01> according to the following conditions. Determine each peak area of both solutions by the automatic integration method: the area of the peak, having the relative retention time of about 0.9 to glimepiride, obtained from the sample solution is not larger than 3/4 times the peak area of glimepiride from the standard solution.

Operating conditions—

Detector: An ultraviolet absorption photometer (wavelength: 228 nm).

Column: A stainless steel column 3 mm in inside diameter and 15 cm in length, packed with diol silica gel for liquid chromatography (5 μm in particle diameter).

Column temperature: A constant temperature of about 25°C.

Mobile phase: A mixture of heptane for liquid chromatography, 2-propanol for liquid chromatography, and acetic acid (100) (900:100:1).

Flow rate: Adjust so that the retention time of glimepiride is about 14 minutes.

System suitability—

Test for required detectability: Pipet 5 mL of the standard solution, and add the mobile phase to make exactly 10 mL. Confirm that the peak area of glimepiride obtained with 10 μL of this solution is equivalent to 35 to 65% of that with 10 μL of the standard solution.

System performance: When the procedure is run with 10 μL of the standard solution under the above operating conditions, the number of theoretical plates and the symmetry factor of the peak of glimepiride are not less than 3000 and not more than 1.5, respectively.

System repeatability: When the test is repeated 6 times with 10 μL of the standard solution under the above operating conditions, the relative standard deviation of the peak area of glimepiride is not more than 2.0%.

(3) Related substances—Keep the sample solution and standard solution below 4°C after preparing. Dissolve 20 mg of Glimepiride in 100 mL of a mixture of acetonitrile for liquid chromatography and water (4:1), and use this solution as the sample solution. Pipet 1 mL of the sample solution, and add the mobile phase to make exactly 100 mL. Pipet 1 mL of this solution, add the mobile phase to make exactly 10 mL, and use this solution as the standard solution. Perform the test with exactly 20 μL each of the sample solution and standard solution as directed under Liquid Chromatography <2.01> according to the following conditions. Determine each peak area of both solutions by the automatic integration method: the area of the peak, having the relative retention time of about 0.25 to glimepiride, obtained from the sample solution is not larger than 4 times the peak area of glimepiride from the standard solution, the area of the peak, having the relative retention time of about 1.1, is not larger than 2 times the peak area of glimepiride from the standard solution, the area of the peak, having the relative retention time of about 0.32, is not larger than 1.5 times the peak area of glimepiride from the standard solution, the area of peak other than glimepiride and above mentioned peak from the sample solution is not larger than the peak of glimepiride from the standard solution, and the total area of the peaks other than glimepiride and the peak, having the relative retention time of about 0.25, from the sample solution is not larger than 5 times the peak area of glimepiride from the standard solution.

Operating conditions—

Detector, column, column temperature, mobile phase, and flow rate: Proceed as directed in the operating conditions in the Assay.

Time span of measurement: About 2.5 times as long as the retention time of glimepiride, beginning after the solvent peak.

System suitability—

Test for required detectability: Pipet 5 mL of the standard solution, and add the mobile phase to make exactly 10 mL. Confirm that the peak area of glimepiride obtained with 20 μL of this solution is equivalent to 35 to 65% of that with 20 μL of the standard solution.

System performance: When the procedure is run with 20 μL of the standard solution under the above operating conditions, the number of theoretical plates and the symmetry factor of the peak of glimepiride are not less than 9000 and not more than 1.5, respectively.

System repeatability: When the test is repeated 6 times

with 20 μL of the standard solution under the above operating conditions, the relative standard deviation of the peak area of glimepiride is not more than 2.0%.

Water <2.48> Not more than 0.5% (0.25 g, coulometric titration).

Residue on ignition <2.44> Not more than 0.2% (1 g).

Assay Weigh accurately about 20 mg each of Glimepiride and Glimepiride RS (separately determine the water <2.48> in the same manner as Glimepiride), dissolve each substance in a mixture of acetonitrile for liquid chromatography and water (4:1) to make exactly 100 mL, and use these solutions as the sample solution and the standard solution, respectively. Perform the test with exactly 20 μL each of the sample solution and standard solution as directed under Liquid Chromatography <2.01> according to the following conditions, and determine the peak areas, A_T and A_S , of glimepiride in each solution.

$$\begin{aligned} &\text{Amount (mg) of glimepiride (C}_{24}\text{H}_{34}\text{N}_4\text{O}_5\text{S)} \\ &= M_S \times A_T/A_S \end{aligned}$$

M_S : Amount (mg) of Glimepiride RS taken, calculated on the anhydrous basis

Operating conditions—

Detector: An ultraviolet absorption photometer (wavelength: 228 nm).

Column: A stainless steel column 4 mm in inside diameter and 25 cm in length, packed with octadecylsilanized silica gel for liquid chromatography (4 μm in particle diameter).

Column temperature: A constant temperature of about 25°C.

Mobile phase: Dissolve 0.5 g of sodium dihydrogen phosphate dihydrate in 500 mL of water, adjust to pH 2.5 with phosphoric acid, and add 500 mL of acetonitrile for liquid chromatography.

Flow rate: Adjust so that the retention time of glimepiride is about 17 minutes.

System suitability—

System performance: When the procedure is run with 20 μL of the standard solution under the above operating conditions, the number of theoretical plates and the symmetry factor of the peak of glimepiride are not less than 9000 and not more than 1.5, respectively.

System repeatability: When the test is repeated 6 times with 20 μL of the standard solution under the above operating conditions, the relative standard deviation of the peak area of glimepiride is not more than 1.0%.

Containers and storage Containers—Well-closed containers.

Glimepiride Tablets

グリメピリド錠

Glimepiride Tablets contain not less than 93.0% and not more than 107.0% of the labeled amount of glimepiride (C₂₄H₃₄N₄O₅S: 490.62).

Method of preparation Prepare as directed under Tablets, with Glimepiride.

Identification To a quantity of powdered Glimepiride Tablets, equivalent to 20 mg of Glimepiride, add 40 mL of acetonitrile, shake for 15 minutes, and centrifuge. Evaporate the supernatant liquid on a water bath under reduced pres-

sure, suspend the residue with 1 mL of water, and filter under reduced pressure. Wash the residue with 1 mL of water, dry at 105°C for 1 hour. Determine the infrared absorption spectrum as directed in the potassium bromide disk method under Infrared Spectrophotometry <2.25>: it exhibits absorption at the wave numbers of about 3370 cm⁻¹, 3290 cm⁻¹, 2930 cm⁻¹, 1708 cm⁻¹, 1674 cm⁻¹, 1347 cm⁻¹, 1156 cm⁻¹ and 618 cm⁻¹.

Purity Related substances—Keep the sample solution and standard solution below 4°C after preparation. To a quantity of powdered Glimepiride Tablets, equivalent to 9 mg of Glimepiride, wet with 0.5 mL of water, add a mixture of acetonitrile for liquid chromatography and water (4:1) to make 50 mL, shake, centrifuge, and use the supernatant liquid as the sample solution. Pipet 1 mL of the sample solution, add a mixture of acetonitrile for liquid chromatography and water (4:1) to make exactly 100 mL, and use this solution as the standard solution. Perform the test with exactly 5 μL each of the sample solution and standard solution as directed under Liquid Chromatography <2.01> according to the following conditions. Determine each peak area of both solutions by the automatic integration method: the area of the peak, having the relative retention time of about 0.3 to glimepiride, obtained from the sample solution is not larger than 2.6 times the peak area of glimepiride from the standard solution, the area of the peak other than glimepiride and the peak mentioned above from the sample solution is not larger than 3/10 times the peak area of glimepiride from the standard solution, and the total area of the peaks other than glimepiride and the peak mentioned above from the sample solution is not larger than the peak area of glimepiride from the standard solution, and the total area of the peaks other than glimepiride from the sample solution is not larger than 3 times the peak area of glimepiride from the standard solution.

Operating conditions—

Detector, column, column temperature, and mobile phase: Proceed as directed in the operating conditions in the Assay.

Flow rate: Adjust so that the retention time of glimepiride is about 12 minutes.

Time span of measurement: About 2 times as long as the retention time of glimepiride.

System suitability—

Test for required detectability: Pipet 2 mL of the standard solution, and add the mobile phase to make exactly 20 mL. Confirm that the peak area of glimepiride obtained with 5 μL of this solution is equivalent to 7 to 13% of that with 5 μL of the standard solution.

System performance: When the procedure is run with 5 μL of the standard solution under the above operating conditions, the number of theoretical plates and the symmetry factor of the peak of glimepiride are not less than 6000 and not more than 1.5, respectively.

System repeatability: When the test is repeated 6 times with 5 μL of the standard solution under the above operating conditions, the relative standard deviation of the peak area of glimepiride is not more than 2.0%.

Uniformity of dosage units <6.02> Perform the test according to the following method: it meets the requirement of the Content uniformity test.

To 1 tablet of Glimepiride Tablets add $V/10$ mL of water, disintegrate, add $V/2$ mL of a mixture of acetonitrile for liquid chromatography and water (4:1), and shake. To this solution add exactly $V/5$ mL of the internal standard solution, add a mixture of acetonitrile for liquid chromatography and water (4:1) to make V mL so that each mL contains about

100 μg of glimepiride ($\text{C}_{24}\text{H}_{34}\text{N}_4\text{O}_5\text{S}$), and centrifuge. To 2.5 mL of the supernatant liquid add a mixture of acetonitrile for liquid chromatography and water (4:1) to make 5 mL, and use this solution as the sample solution. Separately, weigh accurately about 20 mg of Glimepiride RS (separately determine the water <2.48> in the same manner as Glimepiride), and dissolve in a mixture of acetonitrile for liquid chromatography and water (4:1) to make exactly 100 mL. Pipet 5 mL of this solution, add exactly 2 mL of the internal standard solution, add a mixture of acetonitrile for liquid chromatography and water (4:1) to make 20 mL, and use this solution as the standard solution. Then, proceed as directed in the Assay.

$$\begin{aligned} &\text{Amount (mg) of glimepiride (C}_{24}\text{H}_{34}\text{N}_4\text{O}_5\text{S)} \\ &= M_S \times Q_T/Q_S \times V/200 \end{aligned}$$

M_S : Amount (mg) of Glimepiride RS taken, calculated on the anhydrous basis

Internal standard solution—A solution of butyl parahydroxybenzoate in a mixture of acetonitrile for liquid chromatography and water (4:1) (1 in 1000).

Dissolution <6.10> When the test is performed at 50 revolutions per minute according to the Paddle method, using 900 mL of disodium hydrogen phosphate-citric acid buffer solution (pH 7.5) as the dissolution medium, the dissolution rate in 15 minutes of 0.5-mg and 1-mg tablets is not less than 75%, and that in 30 minutes of 3-mg tablet is not less than 70%.

Start the test with 1 tablet of Glimepiride Tablets, withdraw not less than 20 mL of the medium at the specified minute after starting the test, and filter through a membrane filter with a pore size not exceeding 0.45 μm . Discard not less than 10 mL of the first filtrate, pipet V mL of the subsequent filtrate, add the dissolution medium to make exactly V' mL so that each mL contains about 0.56 μg of glimepiride ($\text{C}_{24}\text{H}_{34}\text{N}_4\text{O}_5\text{S}$), and use this solution as the sample solution. Separately, weigh accurately about 22 mg of Glimepiride RS (separately determine the water <2.48> in the same manner as Glimepiride), and dissolve in acetonitrile for liquid chromatography to make exactly 100 mL. Pipet 2 mL of this solution, add 8 mL of acetonitrile for liquid chromatography, and add the dissolution medium to make exactly 200 mL. Pipet 5 mL of this solution, add the dissolution medium to make exactly 20 mL, and use this solution as the standard solution. Perform the test with exactly 50 μL each of the sample solution and standard solution as directed under Liquid Chromatography <2.01> according to the following conditions, and determine the peak areas, A_T and A_S , of glimepiride in each solution.

$$\begin{aligned} &\text{Dissolution rate (\%)} \text{ with respect to the labeled amount} \\ &\text{of glimepiride (C}_{24}\text{H}_{34}\text{N}_4\text{O}_5\text{S)} \\ &= M_S \times A_T/A_S \times V'/V \times 1/C \times 9/4 \end{aligned}$$

M_S : Amount (mg) of Glimepiride RS taken, calculated on the anhydrous basis

C : Labeled amount (mg) of glimepiride ($\text{C}_{24}\text{H}_{34}\text{N}_4\text{O}_5\text{S}$) in 1 tablet

Operating conditions—

Detector, column temperature, mobile phase, and flow rate: Proceed as directed in the operating conditions in the Assay.

Column: A stainless steel column 4.6 mm in inside diameter and 15 cm in length, packed with octadecylsilanized silica gel for liquid chromatography (5 μm in particle diameter).

System suitability—

System performance: When the procedure is run with 50 μL of the standard solution under the above operating conditions, the number of theoretical plates and the symmetry factor of the peak of glimepiride are not less than 3000 and not more than 1.5, respectively.

System repeatability: When the test is repeated 6 times with 50 μL of the standard solution under the above operating conditions, the relative standard deviation of the peak area of glimepiride is not more than 1.5%.

Assay Weigh accurately the mass of not less than 20 Glimepiride Tablets, and powder. Weigh accurately a portion of the powder, equivalent to about 3 mg of glimepiride ($\text{C}_{24}\text{H}_{34}\text{N}_4\text{O}_5\text{S}$), add 3 mL of water, and shake with 30 mL of a mixture of acetonitrile for liquid chromatography and water (4:1). Add exactly 6 mL of the internal standard solution, and add a mixture of acetonitrile for liquid chromatography and water (4:1) to make 50 mL, centrifuge, and use the supernatant liquid as the sample solution. Separately, weigh accurately about 20 mg of Glimepiride RS, (separately, determine the water <2.48> in the same manner as Glimepiride), dissolve in a mixture of acetonitrile for liquid chromatography and water (4:1) to make exactly 100 mL. Pipet 15 mL of this solution, add exactly 6 mL of the internal standard solution, add a mixture of acetonitrile for liquid chromatography and water (4:1) to make 50 mL, and use this solution as the standard solution. Perform the test with 10 μL each of the sample solution and standard solution as directed under Liquid Chromatography <2.01> according to the following conditions, and calculate the ratios, Q_T and Q_S , of the peak area of glimepiride to that of the internal standard.

$$\begin{aligned} &\text{Amount (mg) of glimepiride (C}_{24}\text{H}_{34}\text{N}_4\text{O}_5\text{S)} \\ &= M_S \times Q_T/Q_S \times 3/20 \end{aligned}$$

M_S : Amount (mg) of Glimepiride RS taken, calculated on the anhydrous basis

Internal standard solution—A solution of butyl parahydroxybenzoate in a mixture of acetonitrile for liquid chromatography and water (4:1) (1 in 1000).

Operating conditions—

Detector: An ultraviolet spectrophotometer (wavelength: 228 nm).

Column: A stainless steel column 4 mm in inside diameter and 12.5 cm in length, packed with octadecylsilanized silica gel for liquid chromatography (5 μm in particle diameter).

Column temperature: A constant temperature of about 25°C.

Mobile phase: Dissolve 0.5 g of sodium dihydrogen phosphate dihydrate in 500 mL of water, add 500 mL of acetonitrile for liquid chromatography, and adjust to pH 3.5 with diluted phosphoric acid (1 in 5).

Flow rate: Adjust so that the retention time of glimepiride is about 10 minutes.

System suitability—

System performance: When the procedure is run with 10 μL of the standard solution under the above operating conditions, the internal standard and glimepiride are eluted in this order with the resolution between these peaks being not less than 6.

System repeatability: When the test is repeated 6 times with 10 μL of the standard solution under the above operating conditions, the relative standard deviation of the ratio of the peak area of glimepiride to that of the internal standard is not more than 1.0%.

Containers and storage Containers—Tight containers.

Glucagon (Genetical Recombination)

グルカゴン(遺伝子組換え)

HSQGTFTSDY SKYLDSRRAQ DFFVQWLMNT

C₁₅₃H₂₂₅N₄₃O₄₉S: 3482.75
[16941-32-5]

Glucagon (Genetical Recombination) is a recombinant human glucagon, and is a peptide consisting of 29 amino acid residues.

It contains not less than 92.5% and not more than 105.0% of glucagon, calculated on the anhydrous basis.

Manufacture Glucagon (Genetical Recombination) is manufactured by the process that has been properly validated to be able to manufacture the drug substance having predefined biological activity. When the residual amount of host cell proteins is determined by enzyme immunoassay as in-process tests, the amount should be not more than the control value. In addition, Glucagon (Genetical Recombination) is purified by the process that has been validated that the residual amount of host cell DNA is not more than the control value.

Description Glucagon (Genetical Recombination) occurs as a white lyophilized powder.

It is practically insoluble in water and in ethanol (99.5).

It is hygroscopic.

Identification (1) Dissolve 5 mg of Glucagon (Genetical Recombination) in 1 mL of 0.01 mol/L hydrochloric acid TS. To 200 μL of this solution add 800 μL of 0.1 mol/L ammonium hydrogen carbonate TS and 25 μL of enzyme TS for glucagon, react at 37°C for 2 hours, add 120 μL of acetic acid (100) to stop the reaction, and use this solution as the sample solution. Separately, dissolve a suitable amount of Glucagon RS in 0.1 mol/L ammonium hydrogen carbonate TS so that each mL contains 1 mg of glucagon. To 1000 μL of this solution add 25 μL of enzyme TS for glucagon, react at 37°C for 2 hours, add 120 μL of acetic acid (100) to stop the reaction, and use this solution as the standard solution. Perform the test with 20 μL each of the sample solution and standard solution as directed under Liquid Chromatography <2.01> according to the following conditions, and compare the chromatograms obtained from these solutions: both chromatograms show the similar peaks at the same retention time.

Operating conditions—

Detector: An ultraviolet absorption photometer (wavelength: 215 nm).

Column: A stainless steel column 4 mm in inside diameter and 50 mm in length, packed with octadecylsilanized silica gel for liquid chromatography (5 μm in particle diameter).

Column temperature: A constant temperature of about 22°C.

Mobile phase A: To 0.5 mL of trifluoroacetic acid add 1000 mL of water.

Mobile phase B: To 0.5 mL of trifluoroacetic acid add 600 mL of ethanol (99.5) and 400 mL of water.

Flowing of mobile phase: Control the gradient by mixing the mobile phases A and B as directed in the following table.

Time after injection of sample (min)	Mobile phase A (vol%)	Mobile phase B (vol%)
0 – 35	100 → 53	0 → 47
35 – 45	53 → 0	47 → 100

Flow rate: 1.0 mL per minute.

System suitability—

System performance: When the procedure is run with 20 μL of the standard solution under the above operating conditions, the peaks 1, 2, 3, 4 and 5 are eluted in this order, and the resolution between the peak 2 and the peak 3 is not less than 1.5.

(2) Perform the test with 15 μL each of the sample solution and standard solution obtained in the Assay as directed under Liquid chromatography <2.01> according to the conditions described in the Assay: the retention times of the principal peaks obtained from the sample solution and the standard solution are the same.

Purity Related substances and desamido substances—Conduct this procedure at a temperature between 2°C and 8°C. Dissolve 50 mg of Glucagon (Genetical Recombination) in 100 mL of 0.01 mol/L hydrochloric acid TS, and use this solution as the sample solution. Perform the test with 15 μL of the sample solution as directed under Liquid Chromatography <2.01> according to the following conditions. Determine each peak area by the automatic integration method, and calculate the amounts of them by the area percentage method: the total amount of desamido substance 1 having the relative retention time of about 1.1 to glucagon, desamido substance 2 having the relative retention time of about 1.2, desamido substance 3 having the relative retention time of about 1.3 and desamido substance 4 having the relative retention time of about 1.4 is not more than 0.8%, and the total amount of peaks other than glucagon is not more than 2.0%.

Operating conditions—

Detector, column, column temperature, mobile phases A and B, flowing of mobile phase, and flow rate: Proceed as directed in the operating conditions in the Assay.

Time span of measurement: For 37 minutes after injection, beginning after the solvent peak.

System suitability—

System performance: Proceed as directed in the system suitability in the Assay.

Test for required detectability: When the procedure is run with 15 μL of the standard solution obtained in the Assay under the above operating conditions, the peak corresponding to the desamido substance 2 is detected.

Water <2.48> Not more than 10% (50 mg, coulometric titration).

Assay Conduct this procedure at a temperature between 2°C and 8°C. Weigh accurately about 50 mg of Glucagon (Genetical Recombination), dissolve in 100 mL of 0.01 mol/L hydrochloric acid TS, and use this solution as the sample solution. Separately dissolve Glucagon RS in 0.01 mol/L hydrochloric acid TS so that each mL contains about 0.5 mg of glucagon, and use this solution as the standard solution. Perform the test with exactly 15 μL each of the sample solution and standard solution as directed under Liquid Chromatography <2.01> according to the following conditions, and determine the peak areas, A_T and A_S, of glucagon in each solution.

$$\text{Amount (\%)} \text{ of glucagon} = A_T/A_S \times C_S/C_T \times 100$$

C_S : Concentration (mg/mL) of the standard solution

C_T : Concentration (mg/mL) of the sample solution

The calculated amount (%) of glucagon is corrected by the water content to obtain the amount (%) of glucagon on the anhydrous basis.

Operating conditions—

Detector: An ultraviolet absorption photometer (wavelength: 214 nm).

Column: A stainless steel column 3 mm in inside diameter and 150 mm in length, packed with octadecylsilanized silica gel for liquid chromatography (3 μ m in particle diameter).

Column temperature: A constant temperature of about 45°C.

Mobile phase A: Dissolve 16.3 g of potassium dihydrogen phosphate in 750 mL of water, adjust to pH 2.7 with phosphoric acid, add water to make 800 mL, and add 200 mL of acetonitrile for liquid chromatography.

Mobile phase B: A mixture of water and acetonitrile (3:2).

Flowing of mobile phase: Control the gradient by mixing the mobile phases A and B as directed in the following table.

Time after injection of sample (min)	Mobile phase A (vol%)	Mobile phase B (vol%)
0 – 25*	61	39
25 – 29	61 → 12	39 → 88
29 – 30	12	88
30 – 31	12 → 61	88 → 39
31 – 37	61	39

* Adjust the time for the isocratic condition so that the gradient starts after the desamido substance 4 is eluted.

Flow rate: 0.5 mL per minute.

System suitability—

System performance: Dissolve Glucagon RS in 0.01 mol/L hydrochloric acid TS to make a solution so that each mL contains 0.5 mg of glucagon. Warm this solution at 50°C for 48 hours, and use this solution as the solution for system suitability test. When the procedure is run with 15 μ L of the solution for system suitability test under the above operating conditions, four peaks corresponding to the desamido substances 1, 2, 3 and 4 eluted after the principal peak are clearly detected, the total amount of these peaks is not less than 7%, and the resolution between glucagon and the desamido substance 1 is not less than 1.5. Furthermore, when the procedure is run with 15 μ L of the standard solution under the above operating conditions, the symmetry factor of the principal peak is not more than 1.8.

System repeatability: When the test is repeated 5 times with the standard solution under the above operating conditions, the relative standard deviation of the peak area of glucagon is not more than 2.0%.

Containers and storage Containers—Tight containers.

Storage—Light-resistant, and not exceeding –15°C.

Glucose

ブドウ糖

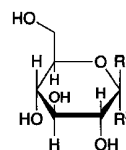

α -D-Glucopyranose : $R^1=H, R^2=OH$
 β -D-Glucopyranose : $R^1=OH, R^2=H$

$C_6H_{12}O_6$: 180.16

D-Glucopyranose

[50-99-7]

Glucose is α -D-glucopyranose, β -D-glucopyranose, or a mixture of them.

It, when dried, contains not less than 99.5% of glucose [D-glucopyranose ($C_6H_{12}O_6$)].

Description Glucose occurs as white, crystals or crystalline powder. It is odorless, and has a sweet taste.

It is freely soluble in water, slightly soluble in ethanol (95), and practically insoluble in diethyl ether.

Identification Add 2 to 3 drops of a solution of Glucose (1 in 20) to 5 mL of boiling Fehling's TS: a red precipitate is produced.

Purity (1) Clarity and color of solution—Add 25 g of Glucose to 30 mL of water in a Nessler tube, warm at 60°C in a water bath until solution is effected, cool, and add water to make 50 mL: the solution is clear and has no more color than the following control solution.

Control solution: To a mixture of 1.0 mL of Cobalt (II) Chloride CS, 3.0 mL of Iron (III) Chloride CS, and 2.0 mL of Copper (II) Sulfate CS, add water to make 10.0 mL. To 3.0 mL of this solution add water to make 50 mL.

(2) **Acidity**—Dissolve 5.0 g of Glucose in 50 mL of freshly boiled and cooled water, and add 3 drops of phenolphthalein TS and 0.60 mL of 0.01 mol/L sodium hydroxide VS: a red color develops.

(3) **Chloride <1.03>**—Perform the test with 2.0 g of Glucose. Prepare the control solution with 1.0 mL of 0.01 mol/L hydrochloric acid VS (not more than 0.018%).

(4) **Sulfate <1.14>**—Perform the test with 2.0 g of Glucose. Prepare the control solution with 1.0 mL of 0.005 mol/L sulfuric acid VS (not more than 0.024%).

(5) **Heavy metals <1.07>**—Proceed with 5.0 g of Glucose according to Method 2, and perform the test. Prepare the control solution with 2.0 mL of Standard Lead Solution (not more than 4 ppm).

(6) **Arsenic <1.11>**—Dissolve 1.5 g of Glucose in 5 mL of water, add 5 mL of dilute sulfuric acid and 1 mL of bromine TS, heat on a water bath for 5 minutes, and concentrate to 5 mL. After cooling, perform the test with this solution as the test solution (not more than 1.3 ppm).

(7) **Dextrin**—To 1.0 g of Glucose add 20 mL of ethanol (95), and boil under a reflux condenser: the solution is clear.

(8) **Soluble starch and sulfite**—Dissolve 1.0 g of Glucose in 10 mL of water, and add 1 drop of iodine TS: a yellow color develops.

Loss on drying <2.41> Not more than 1.0% (1 g, 105°C, 6 hours).

Residue on ignition <2.44> Not more than 0.1% (2 g).

Assay Weigh accurately about 10 g of Glucose, previously dried, dissolve in 0.2 mL of ammonia TS and water to make exactly 100 mL, allow to stand for 30 minutes, and determine the optical rotation, α_D , of this solution at $20 \pm 1^\circ\text{C}$ in a 100-mm cell as directed under Optical Rotation Determination <2.49>.

Amount (mg) of glucose ($\text{C}_6\text{H}_{12}\text{O}_6$) = $\alpha_D \times 1895.4$

Containers and storage Containers—Tight containers.

Glucose Hydrate

ブドウ糖水和物

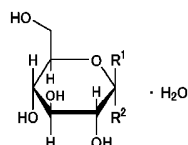

α -D-glucopyranose monohydrate: $\text{R}^1 = \text{H}$, $\text{R}^2 = \text{OH}$

β -D-glucopyranose monohydrate: $\text{R}^1 = \text{OH}$, $\text{R}^2 = \text{H}$

$\text{C}_6\text{H}_{12}\text{O}_6 \cdot \text{H}_2\text{O}$: 198.17

D-Glucopyranose monohydrate

[77938-63-7]

This monograph is harmonized with the European Pharmacopoeia and the U.S. Pharmacopoeia.

The corresponding part of the attributes/provisions which are agreed as non-harmonized within the scope of the harmonization is marked with symbols (◆ ◆), and the corresponding parts which are agreed as the JP local requirement other than the scope of the harmonization are marked with symbols (◇ ◇).

Information on the harmonization with the European Pharmacopoeia and the U.S. Pharmacopoeia is available on the website of the Pharmaceuticals and Medical Devices Agency.

Glucose Hydrate is the monohydrate of D-glucopyranose derived from starch.

It contains not less than 97.5% and not more than 102.0% of glucose [D-glucopyranose ($\text{C}_6\text{H}_{12}\text{O}_6$; 180.16)], calculated on the anhydrous basis.

◆**Description** Glucose Hydrate occurs as white, crystals or crystalline powder, and has a sweet taste.

It is freely soluble in water, sparingly soluble in methanol, and slightly soluble in ethanol (95).◆

Identification ◇(1) Add 2 to 3 drops of a solution of Glucose Hydrate (1 in 20) to 5 mL of boiling Fehling's TS: a red precipitate is produced.◇

(2) Perform the test with 20 μL each of the sample solution and standard solution obtained in the Assay as directed under Liquid Chromatography <2.01> according to the following conditions: the principal peak in the chromatogram obtained from the sample solution is similar in retention time and size to the principal peak in the chromatogram from the standard solution.

Operating conditions—

Proceed as directed in the operating conditions in the Assay.

System suitability—

Proceed as directed in the system suitability in the Assay.

Purity (1) Clarity and color of solution—Dissolve 10.0 g of Glucose Hydrate in 15 mL of water, and use this solution as the test solution. Perform the test with the test solution as directed under Turbidity Measurement <2.61>: the solution is clear. Perform the test with the test solution according to Method 2 under Methods for Color Matching <2.65>: the solution is not more colored than Matching Fluid BY7.

◆(2) Heavy metals <1.07>—Proceed with 5.0 g of Glucose Hydrate according to Method 2, and perform the test. Prepare the control solution with 2.0 mL of Standard Lead Solution (not more than 4 ppm).◆

(3) Related substances—Use the sample solution obtained in the Assay as the sample solution. Pipet 1 mL of the sample solution, add water to make exactly 250 mL, and use this solution as the standard solution (1). Pipet 25 mL of the standard solution (1), add water to make exactly 200 mL, and use this solution as the standard solution (2). Perform the test with exactly 20 μL each of the sample solution, the standard solution (1) and the standard solution (2) as directed under Liquid Chromatography <2.01> according to the following conditions. Determine each peak area by the automatic integration method: the total area of the peaks of maltose and isomaltose, having the relative retention time of about 0.8 to glucose, obtained from the sample solution, is not larger than the peak area of glucose from the standard solution (1) (not more than 0.4%), and the peak area of maltotriose, having the relative retention time of about 0.7 from the sample solution, is not larger than 1/2 times the peak area of glucose from the standard solution (1) (not more than 0.2%), and the peak area of fructose, having the relative retention time of about 1.3 from the sample solution, is not larger than 3 times the peak area of glucose from the standard solution (2) (not more than 0.15%), and the area of the peak other than glucose and the peaks mentioned above from the sample solution is not larger than 2 times the peak area of glucose from the standard solution (2) (not more than 0.10%). Furthermore, the total area of the peaks other than glucose from the sample solution is not larger than 1.25 times the peak area of glucose from the standard solution (1) (not more than 0.5%). For these calculations the peak areas not larger than the peak area of glucose from the standard solution (2) are excluded (disregard limit: 0.05%).

Operating conditions—

Detector, column, column temperature, mobile phase and flow rate: Proceed as directed in the operating conditions in the Assay.

Time span of measurement: About 1.5 times as long as the retention time of glucose.

System suitability—

System performance: Proceed as directed in the system suitability in the Assay.

◇Test for required detectability: Confirm that the peak area of glucose obtained with 20 μL of the standard solution (2) is equivalent to 8.8 to 16.3% of that with 20 μL of the standard solution (1).

System repeatability: When the test is repeated 6 times with 20 μL of the standard solution (1) under the above operating conditions, the relative standard deviation of the peak area of glucose is not more than 1.0%.◇

(4) Dextrin—To 1.0 g of powdered Glucose Hydrate add 20 mL of ethanol (95), and boil under a reflux condenser: the solution is clear.

(5) Soluble starch and sulfite—To 7.4 g of Glucose Hydrate add 15 mL of water, dissolve by heating on a water bath, cool, and add 25 μL of 0.05 mol/L iodine VS: a yellow color develops (not more than 15 ppm as SO_3).

Conductivity <2.51> Dissolve 20.0 g of Glucose Hydrate in a freshly boiled and cooled distilled water to make 100 mL, and use this solution as the sample solution. Measure the conductivity of the sample solution at $25 \pm 0.1^\circ\text{C}$ while gently stirring with a magnetic stirrer: not more than $20 \mu\text{S}\cdot\text{cm}^{-1}$.

Water <2.48> 7.5–9.5% (0.25 g, volumetric titration, direct titration).

Assay Weigh accurately about 0.33 g of Glucose Hydrate and 0.3 g of \blacklozenge Glucose RS \blacklozenge (separately determine the water <2.48> in the same manner as Purified Glucose), dissolve separately in water to make exactly 10 mL, and use these solutions as the sample solution and the standard solution, respectively. Perform the test with exactly $20 \mu\text{L}$ each of the sample solution and standard solution as directed under Liquid Chromatography <2.01> according to the following conditions, and determine the peak areas, A_T and A_S , of glucose in each solution.

$$\text{Amount (g) of glucose (C}_6\text{H}_{12}\text{O}_6) = M_S \times A_T/A_S$$

M_S : Amount (g) of Glucose RS taken, calculated on the anhydrous basis

Operating conditions—

Detector: A differential refractometer maintained at a constant temperature (40°C for example).

Column: A stainless steel column 7.8 mm in inside diameter and 30 cm in length, packed with strongly acidic ion-exchange resin for liquid chromatography (Ca type) composed with a sulfonated polystyrene cross-linked with divinylbenzene (degree of cross-linkage: 8%) ($9 \mu\text{m}$ in particle diameter).

Column temperature: A constant temperature of about 85°C .

Mobile phase: Water.

Flow rate: 0.3 mL per minute (the retention time of glucose is about 21 minutes).

System suitability—

System performance: Dissolve 5 mg of maltose, 5 mg of maltotriose and 5 mg of fructose in 50 mL of water, and use this solution as the solution for system suitability test. When the procedure is run with $20 \mu\text{L}$ each of the solution for system suitability test and the standard solution (2) in Purity (3) under the above operating conditions, maltotriose, maltose, glucose and fructose are eluted in this order, the relative retention times of maltotriose, maltose, isomaltose and fructose to glucose are about 0.7, about 0.8, about 0.8 and about 1.3, respectively, and the resolution between the peaks of maltotriose and maltose is not less than 1.3.

\diamond System repeatability: When the test is repeated 6 times with $20 \mu\text{L}$ of the standard solution under the above operating conditions, the relative standard deviation of the peak area of glucose is not more than 1.0%. \diamond

\blacklozenge **Containers and storage** Containers—Tight containers. \blacklozenge

Purified Glucose

精製ブドウ糖

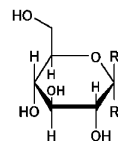

α -D-glucopyranose: $R^1 = \text{H}$, $R^2 = \text{OH}$

β -D-glucopyranose: $R^1 = \text{OH}$, $R^2 = \text{H}$

$\text{C}_6\text{H}_{12}\text{O}_6$: 180.16

D-Glucopyranose

[50-99-7]

This monograph is harmonized with the European Pharmacopoeia and the U.S. Pharmacopoeia.

The corresponding part of the attributes/provisions which are agreed as non-harmonized within the scope of the harmonization is marked with symbols (\blacklozenge \blacklozenge), and the corresponding parts which are agreed as the JP local requirement other than the scope of the harmonization are marked with symbols (\diamond \diamond).

Information on the harmonization with the European Pharmacopoeia and the U.S. Pharmacopoeia is available on the website of the Pharmaceuticals and Medical Devices Agency.

Purified Glucose is D-glucopyranose derived from starch.

It contains not less than 97.5% and not more than 102.0% of glucose [D-glucopyranose ($\text{C}_6\text{H}_{12}\text{O}_6$)], calculated on the anhydrous basis.

\blacklozenge **Description** Purified Glucose occurs as white, crystals or crystalline powder, and has a sweet taste.

It is freely soluble in water, and slightly soluble in methanol and in ethanol (95). \blacklozenge

Identification \diamond (1) Add 2 to 3 drops of a solution of Purified Glucose (1 in 20) to 5 mL of boiling Fehling's TS: a red precipitate is produced. \diamond

(2) Perform the test with $20 \mu\text{L}$ each of the sample solution and standard solution obtained in the Assay as directed under Liquid Chromatography <2.01> according to the following conditions: the principal peak in the chromatogram obtained from the sample solution is similar in retention time and size to the principal peak in the chromatogram from the standard solution.

Operating conditions—

Proceed as directed in the operating conditions in the Assay.

System suitability—

Proceed as directed in the system suitability in the Assay.

Purity (1) Clarity and color of solution—Dissolve 10.0 g of Purified Glucose in 15 mL of water by heating on a water bath, and allow to cool to room temperature, and use this solution as the test solution. Perform the test with the test solution as directed under Turbidity Measurement <2.61>: the solution is clear. Perform the test with the test solution according to Method 2 under Methods for Color Matching <2.65>: the solution is not more colored than Matching Fluid BY7.

\blacklozenge (2) Heavy metals <1.07>—Proceed with 5.0 g of Puri-

fied Glucose according to Method 2, and perform the test. Prepare the control solution with 2.0 mL of Standard Lead Solution (not more than 4 ppm).◆

(3) Related substances—Use the sample solution obtained in the Assay as the sample solution. Pipet 1 mL of the sample solution, add water to make exactly 250 mL, and use this solution as the standard solution (1). Pipet 25 mL of the standard solution (1), add water to make exactly 200 mL, and use this solution as the standard solution (2). Perform the test with exactly 20 μ L each of the sample solution, the standard solution (1) and the standard solution (2) as directed under Liquid Chromatography <2.01> according to the following conditions. Determine each peak area by the automatic integration method: the total area of the peaks of maltose and isomaltose, having the relative retention time of about 0.8 to glucose, obtained from the sample solution, is not larger than the peak area of glucose from the standard solution (1) (not more than 0.4%), and the peak area of maltotriose, having the relative retention time of about 0.7 from the sample solution, is not larger than 1/2 times the peak area of glucose from the standard solution (1) (not more than 0.2%), and the peak area of fructose, having the relative retention time of about 1.3 from the sample solution, is not larger than 3 times the peak area of glucose from the standard solution (2) (not more than 0.15%), and the area of the peak other than glucose and the peaks mentioned above from the sample solution is not larger than 2 times the peak area of glucose from the standard solution (2) (not more than 0.10%). Furthermore, the total area of the peaks other than glucose from the sample solution is not larger than 1.25 times the peak area of glucose from the standard solution (1) (not more than 0.5%). For these calculations the peak areas not larger than the peak area of glucose from the standard solution (2) are excluded (disregard limit: 0.05%).

Operating conditions—

Detector, column, column temperature, mobile phase and flow rate: Proceed as directed in the operating conditions in the Assay.

Time span of measurement: About 1.5 times as long as the retention time of glucose.

System suitability—

System performance: Proceed as directed in the system suitability in the Assay.

◇Test for required detectability: Confirm that the peak area of glucose obtained with 20 μ L of the standard solution (2) is equivalent to 8.8 to 16.3% of that with 20 μ L of the standard solution (1).

System repeatability: When the test is repeated 6 times with 20 μ L of the standard solution (1) under the above operating conditions, the relative standard deviation of the peak area of glucose is not more than 1.0%.◇

(4) Dextrin—To 1.0 g of powdered Purified Glucose add 20 mL of ethanol (95), and boil under a reflux condenser: the solution is clear.

(5) Soluble starch and sulfite—To 6.7 g of Purified Glucose add 15 mL of water, dissolve by heating on a water bath, cool, and add 25 μ L of 0.05 mol/L iodine VS: a yellow color develops (not more than 15 ppm as SO₃).

Conductivity <2.51> Dissolve 20.0 g of Purified Glucose in a freshly boiled and cooled distilled water to make 100 mL, and use this solution as the sample solution. Measure the conductivity of the sample solution at 25 \pm 0.1°C while gently stirring with a magnetic stirrer: not more than 20 μ S·cm⁻¹.

Water <2.48> Not more than 1.0% (0.5 g, volumetric titration, direct titration).

Assay Weigh accurately about 0.3 g each of Purified Glucose and ◆Glucose RS◆ (separately determine the water <2.48> in the same manner as Purified Glucose), dissolve separately in water to make exactly 10 mL, and use these solutions as the sample solution and the standard solution, respectively. Perform the test with exactly 20 μ L each of the sample solution and standard solution as directed under Liquid Chromatography <2.01> according to the following conditions, and determine the peak areas, A_T and A_S, of glucose in each solution.

$$\text{Amount (g) of glucose (C}_6\text{H}_{12}\text{O}_6) = M_S \times A_T/A_S$$

M_S: Amount (g) of Glucose RS taken, calculated on the anhydrous basis

Operating conditions—

Detector: A differential refractometer maintained at a constant temperature (40°C for example).

Column: A stainless steel column 7.8 mm in inside diameter and 30 cm in length, packed with strongly acidic ion-exchange resin for liquid chromatography (Ca type) composed with a sulfonated polystyrene cross-linked with divinylbenzene (degree of cross-linkage: 8%) (9 μ m in particle diameter).

Column temperature: A constant temperature of about 85°C.

Mobile phase: Water.

Flow rate: 0.3 mL per minute (the retention time of glucose is about 21 minutes).

System suitability—

System performance: Dissolve 5 mg of maltose, 5 mg of maltotriose and 5 mg of fructose in 50 mL of water, and use this solution as the solution for system suitability test. When the procedure is run with 20 μ L each of the solution for system suitability test and the standard solution (2) in Purity (3) under the above operating conditions, maltotriose, maltose, glucose and fructose are eluted in this order, the relative retention times of maltotriose, maltose, isomaltose and fructose to glucose are about 0.7, about 0.8, about 0.8 and about 1.3, respectively, and the resolution between the peaks of maltotriose and maltose is not less than 1.3.

◇System repeatability: When the test is repeated 6 times with 20 μ L of the standard solution under the above operating conditions, the relative standard deviation of the peak area of glucose is not more than 1.0%.◇

◆**Containers and storage** Containers—Tight containers.◆

Glucose Injection

ブドウ糖注射液

Glucose Injection is an aqueous injection.

It contains not less than 95.0% and not more than 105.0% of the labeled amount of glucose (C₆H₁₂O₆; 180.16).

Method of preparation Prepare as directed under Injections, with Purified Glucose or Glucose Hydrate.

No preservative is added.

Description Glucose Injection is a clear, colorless liquid. It has a sweet taste. It occurs as a colorless to pale yellow, clear liquid when its labeled concentration exceeds 40%.

Identification Measure a volume of Glucose Injection, equivalent to 0.1 g of glucose (C₆H₁₂O₆), and, if necessary, add water or evaporate on a water bath to make 2 mL. Add

2 to 3 drops of the solution to 5 mL of boiling Fehling's TS: a red precipitate is produced.

pH <2.54> 3.5 – 6.5 In the case where the labeled concentration of the injection exceeds 5%, dilute to 5% with water before the test.

Purity 5-Hydroxymethylfurfural and related substances—Pipet a volume of Glucose Injection, equivalent to 2.5 g of glucose (C₆H₁₂O₆), and add water to make exactly 100 mL. Determine the absorbance of this solution at 284 nm as directed under Ultraviolet-visible Spectrophotometry <2.24>: it is not more than 0.80.

Bacterial endotoxins <4.01> Less than 0.50 EU/mL.

Extractable volume <6.05> It meets the requirement.

Foreign insoluble matter <6.06> Perform the test according to Method 1: it meets the requirement.

Insoluble particulate matter <6.07> It meets the requirement.

Sterility <4.06> Perform the test according to the Membrane filtration method: it meets the requirement.

Assay Measure accurately a volume of Glucose Injection, equivalent to about 4 g of glucose (C₆H₁₂O₆), and add 0.2 mL of ammonia TS and water to make exactly 100 mL. Shake the solution well, allow to stand for 30 minutes, and determine the optical rotation, α_D, at 20 ± 1°C in a 100-mm cell as directed under Optical Rotation Determination <2.49>.

$$\text{Amount (mg) of glucose (C}_6\text{H}_{12}\text{O}_6) = \alpha_D \times 1895.4$$

Containers and storage Containers—Hermetic containers. Plastic containers for aqueous injections may be used.

L-Glutamic Acid

L-グルタミン酸

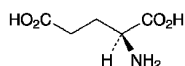

C₅H₉NO₄: 147.13

(2S)-2-Aminopentanedioic acid

[56-86-0]

L-Glutamic Acid contains not less than 99.0% and not more than 101.0% of L-glutamic acid (C₅H₉NO₄), calculated on the dried basis.

Description L-Glutamic acid occurs as white, crystals or crystalline powder. It has a slight characteristic and acid taste.

It is slightly soluble in water, and practically insoluble in ethanol (99.5).

It dissolves in 2 mol/L hydrochloric acid TS.

It shows crystal polymorphism.

Identification Determine the infrared absorption spectrum of L-Glutamic Acid as directed in the potassium bromide disk method under Infrared Spectrophotometry <2.25>, and compare the spectrum with the Reference Spectrum: both spectra exhibit similar intensities of absorption at the same wave numbers. If any difference appears between the spectra, dissolve L-Glutamic Acid in a small amount of water, evaporate water at 60°C under reduced pressure, and perform the test in the same manner with the dried residue.

Optical rotation <2.49> [α]_D²⁰: +31.5 – +32.5° (2.5 g calculated on the dried basis, 2 mol/L hydrochloric acid TS, 25 mL, 100 mm).

pH <2.54> The pH of a solution prepared by dissolving 0.7 g of L-Glutamic Acid in 100 mL of water by warming and then cooling is 2.9 to 3.9.

Purity (1) Clarity and color of solution—Dissolve 1.0 g of L-Glutamic Acid in 10 mL of 2 mol/L hydrochloric acid TS: the solution is clear and colorless.

(2) Chloride <1.03>—Dissolve 0.5 g of L-Glutamic Acid in 6 mL of dilute nitric acid and 20 mL of water, and add water to make 50 mL. Perform the test using this solution as the test solution. Prepare the control solution with 0.30 mL of 0.01 mol/L hydrochloric acid VS (not more than 0.021%).

(3) Sulfate <1.14>—Dissolve 0.6 g of L-Glutamic Acid in 5 mL of dilute hydrochloric acid and 30 mL of water, and add water to make 45 mL. Perform the test using this solution as the test solution. Prepare the control solution from 0.35 mL of 0.005 mol/L sulfuric acid VS and 5 mL of dilute hydrochloric acid, and dilute with water to 45 mL. Prepare the test solution and the control solution with 5 mL of barium chloride TS, respectively (not more than 0.028%).

(4) Ammonium <1.02>—Perform the test with 0.25 g of L-Glutamic Acid. Prepare the control solution with 5.0 mL of Standard Ammonium Solution (not more than 0.02%).

(5) Heavy metals <1.07>—Dissolve 1.0 g of L-Glutamic Acid in 20 mL of water and 7 mL of a solution of sodium hydroxide (1 in 25) by warming, cool, and add 2 mL of dilute acetic acid and water to make 50 mL. Perform the test using this solution as the test solution. Prepare the control solution from 1.0 mL of Standard Lead Solution and 2 mL of dilute acetic acid, and dilute with water to 50 mL (not more than 10 ppm).

(6) Iron <1.10>—Prepare the test solution with 1.0 g of L-Glutamic Acid according to Method 1, and perform the test according to Method A. Prepare the control solution with 1.0 mL of Standard Iron Solution (not more than 10 ppm).

(7) Related substances—Weigh accurately about 0.5 g of L-Glutamic Acid, and dissolve in 0.5 mL of hydrochloric acid and water to make exactly 100 mL. Pipet 10 mL of this solution, add 0.02 mol/L hydrochloric acid TS to make exactly 50 mL, and use this solution as the sample solution. Separately, weigh accurately an amount, equivalent to 2.5 mmol, of L-aspartic acid, L-threonine, L-serine, L-glutamic acid, glycine, L-alanine, L-cystine, L-valine, L-methionine, L-isoleucine, L-leucine, L-tyrosine, L-phenylalanine, L-lysine hydrochloride, ammonium chloride, L-histidine and L-arginine, dissolve them in 0.1 mol/L hydrochloric acid TS to make exactly 1000 mL, and use this solution as the standard stock solution. Pipet 5 mL of the standard stock solution, and add 0.02 mol/L hydrochloric acid TS to make exactly 100 mL. Pipet 6 mL of this solution, add 0.02 mol/L hydrochloric acid TS to make exactly 50 mL, and use this solution as the standard solution. Perform the test with exactly 20 μL each of the sample solution and standard solution as directed under Liquid Chromatography <2.01> according to the following conditions, and calculate the mass percentage of each amino acid, using the mass of amino acid other than glutamic acid in 1 mL of the sample solution obtained from the height of the peaks obtained from the sample solution and standard solution: the amount of each amino acid other than glutamic acid is not more than 0.2%, and the total amount of these amino acids is not more than 0.6%.

Operating conditions—

Detector: A visible absorption photometer (wavelength:

570 nm).

Column: A stainless steel column 4.6 mm in inside diameter and 8 cm in length, packed with strongly acidic ion-exchange resin for liquid chromatography (Na type) composed with a sulfonated polystyrene (3 μ m in particle diameter).

Column temperature: A constant temperature of about 57°C.

Chemical reaction bath temperature: A constant temperature of about 130°C.

Reaction time: About 1 minute.

Mobile phase: Prepare the mobile phases A, B, C, D and E according to the following table, and add 0.1 mL each of caprylic acid.

Mobile phase	A	B	C	D	E
Citric acid monohydrate	19.80 g	22.00 g	12.80 g	6.10 g	—
Trisodium citrate dihydrate	6.19 g	7.74 g	13.31 g	26.67 g	—
Sodium chloride	5.66 g	7.07 g	3.74 g	54.35 g	—
Sodium hydroxide	—	—	—	—	8.00 g
Ethanol (99.5)	130 mL	20 mL	4 mL	—	100 mL
Thiodiglycol	5 mL	5 mL	5 mL	—	—
Benzyl alcohol	—	—	—	5 mL	—
Lauromacrogol solution (1 in 4)	4 mL	4 mL	4 mL	4 mL	4 mL
Water	a sufficient amount	a sufficient amount	a sufficient amount	a sufficient amount	a sufficient amount
Total amount	1000 mL	1000 mL	1000 mL	1000 mL	1000 mL

Changing of mobile phase: Switch the mobile phases A, B, C, D and E sequentially so that when proceed with 20 μ L of the standard solution under the above conditions, aspartic acid, threonine, serine, glutamic acid, glycine, alanine, cystine, valine, methionine, isoleucine, leucine, tyrosine, phenylalanine, lysine, ammonia, histidine and arginine are eluted in this order with the resolution between the peaks of isoleucine and leucine being not less than 1.2.

Reaction reagent: Dissolve 204 g of lithium acetate dihydrate in an appropriate amount of water, add 123 mL of acetic acid (100), 401 mL of 1-methoxy-2-propanol and water to make 1000 mL, introduce nitrogen for 10 minutes, and use this solution as Solution (I). Separately, to 979 mL of 1-methoxy-2-propanol add 39 g of ninhydrin, introduce nitrogen for 5 minutes, add 81 mg of sodium borohydride, introduce nitrogen for 30 minutes, and use this solution as Solution (II). Prepare a mixture with an equal volume of the Solution (I) and Solution (II) (Prepare before use).

Flow rate of mobile phase: 0.20 mL per minute.

Flow rate of reaction reagent: 0.24 mL per minute.

System suitability—

System performance: When the test is run with 20 μ L of the standard solution under the above operating conditions, the resolution between the peaks of glycine and L-alanine is not less than 1.2.

System repeatability: When the test is repeated 6 times with 20 μ L of the standard solution under the above operating conditions, the relative standard deviation of the peak height of each amino acid in the standard solution is not more than 5.0%, and the relative standard deviation of the retention time of them is not more than 1.0%.

Loss on drying <2.41> Not more than 0.3% (1 g, 105°C, 3 hours).

Residue on ignition <2.44> Not more than 0.1% (1 g).

Assay Weigh accurately about 0.12 g of L-Glutamic Acid, dissolve in 40 mL of water by warming, cool, and titrate <2.50> with 0.1 mol/L sodium hydroxide VS (potentiometric titration). Perform a blank determination in the same manner, and make any necessary correction.

Each mL of 0.1 mol/L sodium hydroxide VS
= 14.71 mg of C₅H₉NO₄

Containers and storage Containers—Tight containers.

L-Glutamine

L-グルタミン

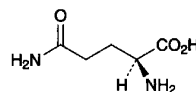

C₅H₁₀N₂O₃: 146.14
(2S)-2,5-Diamino-5-oxopentanoic acid
[56-85-9]

L-Glutamine, when dried, contains not less than 99.0% and not more than 101.0% of L-glutamine (C₅H₁₀N₂O₃).

Description L-Glutamine occurs as white, crystals or a crystalline powder. It has a slight characteristic taste.

It is freely soluble in formic acid, soluble in water, and practically insoluble in ethanol (99.5).

Identification Determine the infrared absorption spectrum of L-Glutamine as directed in the potassium bromide disk method under Infrared Spectrophotometry <2.25>, and compare the spectrum with the Reference Spectrum: both spectra exhibit similar intensities of absorption at the same wave numbers.

Optical rotation <2.49> [α]_D²⁰: +6.3 – +7.3° Weigh accurately about 2 g of L-Glutamine, previously dried, add 45 mL of water, warm to 40°C to dissolve, and after cooling, add water to make exactly 50 mL. Determine the optical rotation of this solution in a 100-mm cell, within 60 minutes.

pH <2.54> The pH of a solution prepared by dissolving 1.0 g of L-Glutamine in 50 mL of water is between 4.5 and 6.0.

Purity (1) Clarity and color of solution—A solution obtained by dissolving 0.5 g of L-Glutamine in 20 mL of water is clear and colorless.

(2) Chloride <1.03>—Perform the test with 0.5 g of L-Glutamine. Prepare the control solution with 0.30 mL of 0.01 mol/L hydrochloric acid VS (not more than 0.021%).

(3) Sulfate <1.14>—Perform the test with 0.6 g of L-Glutamine. Prepare the control solution with 0.35 mL of 0.005 mol/L sulfuric acid VS (not more than 0.028%).

(4) Ammonium <1.02>—Perform the test with 0.10 g of L-Glutamine, using the distillation under reduced pressure. Prepare the control solution with 10.0 mL of Standard Ammonium Solution. The temperature of the water bath is 45°C (not more than 0.1%).

(5) Heavy metals <1.07>—Proceed with 1.0 g of L-Glutamine according to Method 1, and perform the test. Prepare the control solution with 1.0 mL of Standard Lead Solution (not more than 10 ppm).

(6) Iron <1.10>—Prepare the test solution with 1.0 g of

L-Glutamine according to Method 1, and perform the test according to Method A. Prepare the control solution with 1.0 mL of Standard Iron Solution (not more than 10 ppm).

(7) Related substances—Dissolve 0.10 g of L-Glutamine in 10 mL of water, and use this solution as the sample solution. Pipet 1 mL of the sample solution, add water to make exactly 10 mL. Pipet 1 mL of this solution, add water to make exactly 50 mL, and use this solution as the standard solution. Perform the test with these solutions as directed under Thin-layer Chromatography <2.03>. Spot 5 μ L each of the sample solution and standard solution on a plate of silica gel for thin-layer chromatography. Then develop with a mixture of 1-butanol, water and acetic acid (100) (3:1:1) to a distance of about 10 cm, and dry the plate at 80°C for 30 minutes. Spray evenly a solution of ninhydrin in a mixture of methanol and acetic acid (100) (97:3) (1 in 100) on the plate, and heat the plate at 80°C for 10 minutes: the spot other than the principal spot obtained from the sample solution is not more intense than the spot from the standard solution.

Loss on drying <2.41> Not more than 0.3% (1 g, 105°C, 3 hours).

Residue on Ignition <2.44> Not more than 0.1% (1 g).

Assay Weigh accurately about 0.15 g of L-Glutamine, previously dried, dissolve in 3 mL of formic acid, add 50 mL of acetic acid (100), and titrate <2.50> with 0.1 mol/L perchloric acid VS (potentiometric titration). Perform a blank determination in the same manner, and make any necessary correction.

Each mL of 0.1 mol/L perchloric acid VS
= 14.61 mg of C₅H₁₀N₂O₃

Containers and storage Containers—Tight containers.

Glutathione

グルタチオン

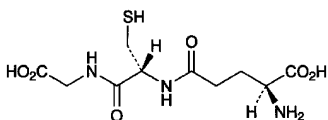

C₁₀H₁₇N₃O₆S: 307.32

(2S)-2-Amino-4-[1-(carboxymethyl)carbamoyl-(2R)-2-sulfanylethylcarbamoyl]butanoic acid
[70-18-8]

Glutathione, when dried, contains not less than 98.0% and not more than 101.0% of glutathione (C₁₀H₁₇N₃O₆S).

Description Glutathione occurs as a white crystalline powder.

It is freely soluble in water, and practically insoluble in ethanol (99.5).

Melting point: about 185°C (with decomposition).

Identification Determine the infrared absorption spectrum of Glutathione, previously dried, as directed in the potassium bromide disk method under Infrared Spectrophotometry <2.25>, and compare the spectrum with the Reference Spectrum: both spectra exhibit similar intensities of absorption at the same wave numbers.

Optical rotation <2.49> $[\alpha]_D^{20}$: -15.5 - -17.5° (after drying, 2 g, water, 50 mL, 100 mm).

Purity (1) Clarity and color of solution—Dissolve 1.0 g of Glutathione in 10 mL of water: the solution is clear and colorless.

(2) Heavy metals <1.07>—Proceed with 2.0 g of Glutathione according to Method 2, and perform the test. Prepare the control solution with 2.0 mL of Standard Lead Solution (not more than 10 ppm).

(3) Arsenic <1.11>—Prepare the test solution with 1.0 g of Glutathione according to Method 1, and perform the test (not more than 2 ppm).

(4) Related substances—Dissolve 50 mg of Glutathione in 100 mL of the mobile phase, and use this solution as the sample solution. Pipet 2 mL of the sample solution, add the mobile phase to make exactly 100 mL, and use this solution as the standard solution. Perform the test with exactly 10 μ L each of the sample solution and standard solution as directed under Liquid Chromatography <2.01> according to the following conditions, and determine each peak area by the automatic integration method: the area of the peak having the relative retention time of about 4 to glutathione obtained from the sample solution is not larger than 3/4 times the peak area of glutathione from the standard solution, and the total area of the peaks other than glutathione is not larger than the peak area of glutathione from the standard solution.

Operating conditions—

Detector: An ultraviolet absorption photometer (wavelength: 210 nm).

Column: A stainless steel column 4.6 mm in inside diameter and 15 cm in length, packed with octadecylsilanized silica gel for liquid chromatography (5 μ m in particle diameter).

Column temperature: A constant temperature of about 30°C.

Mobile phase: Dissolve 6.8 g of potassium dihydrogen phosphate and 2.02 g of sodium 1-heptane sulfonate in 1000 mL of water, and adjust the pH to 3.0 with phosphoric acid. To 970 mL of this solution add 30 mL of methanol.

Flow rate: Adjust so that the retention time of glutathione is about 5 minutes.

Time span of measurement: About 6 times as long as the retention time of glutathione, beginning after the solvent peak.

System suitability—

Test for required detectability: Pipet 10 mL of the standard solution, and add the mobile phase to make exactly 100 mL. Confirm that the peak area of glutathione obtained with 10 μ L of this solution is equivalent to 8 to 12% of that with 10 μ L of the standard solution.

System performance: Dissolve 50 mg of glutathione, 10 mg of D-phenylglycine and 50 mg of ascorbic acid in 100 mL of water. When the procedure is run with 10 μ L of this solution under the above operating conditions, ascorbic acid, glutathione and D-phenylglycine are eluted in this order, and the resolutions between the peaks of ascorbic acid and glutathione and between the peaks of glutathione and D-phenylglycine are not less than 5, respectively.

System repeatability: When the test is repeated 6 times with 10 μ L of the standard solution under the above operating conditions, the relative standard deviation of the peak area of glutathione is not more than 1.5%.

Loss on drying <2.41> Not more than 0.5% (1 g, 105°C, 3 hours).

Residue on ignition <2.44> Not more than 0.1% (1 g).

Assay Weigh accurately about 0.5 g of Glutathione, previously dried, dissolve in 50 mL of a solution of metaphos-

phoric acid (1 in 50), and titrate <2.50> with 0.05 mol/L iodine VS (indicator: 1 mL of starch TS). Perform a blank determination in the same manner, and make any necessary correction.

Each mL of 0.05 mol/L iodine VS
= 30.73 mg of $C_{10}H_{17}N_3O_6S$

Containers and storage Containers—Tight containers.

Glycerin

Glycerol

グリセリン

$C_3H_8O_3$: 92.09

Glycerin contains not less than 84.0% and not more than 87.0% of glycerin ($C_3H_8O_3$).

Description Glycerin is a clear, colorless, viscous liquid. It has a sweet taste.

It is miscible with water and with ethanol (99.5).

It is hygroscopic.

Identification Determine the infrared absorption spectrum of Glycerin as directed in the liquid film method under Infrared Spectrophotometry <2.25>, and compare the spectrum with the Reference Spectrum: both spectra exhibit similar intensities of absorption at the same wave numbers.

Refractive index <2.45> n_D^{20} : 1.449 – 1.454

Specific gravity <2.56> d_{20}^{20} : 1.221 – 1.230

Purity (1) Color—Place 50 mL of Glycerin in a Nessler tube, and observe downward: the solution has no more color than the following control solution.

Control solution: Place 0.40 mL of Iron (III) Chloride CS in a Nessler tube, and add water to make 50 mL.

(2) Acidity or alkalinity—To 2 mL of Glycerin add 8 mL of water and mix: the solution is neutral.

(3) Chloride <1.03>—Take 10.0 g of Glycerin, and perform the test: Prepare the control solution with 0.30 mL of 0.01 mol/L hydrochloric acid VS (not more than 0.001%).

(4) Sulfate <1.14>—Take 10.0 g of Glycerin, and perform the test. Prepare the control solution with 0.40 mL of 0.005 mol/L sulfuric acid VS (not more than 0.002%).

(5) Ammonium—To 5 mL of Glycerin add 5 mL of a solution of sodium hydroxide (1 in 10), and boil: the gas evolved does not change moistened red litmus paper to blue.

(6) Heavy metals <1.07>—Proceed with 5.0 g of Glycerin according to Method 1, and perform the test: Prepare the control solution with 2.5 mL of Standard Lead Solution (not more than 5 ppm).

(7) Calcium—To 5 mL of the solution obtained in (2) add 3 drops of ammonium oxalate TS: the solution remains unchanged.

(8) Arsenic <1.11>—Prepare the test solution with 1.0 g of Glycerin according to Method 1, and perform the test (not more than 2 ppm).

(9) Acrolein, glucose, and other reducing substances—To 1.0 g of Glycerin add 1 mL of ammonia TS, mix, and warm in a water bath at 60°C for 5 minutes: no yellow color is produced. Take the solution out of the water bath, add 3 drops of silver nitrate TS immediately, and allow to stand in a dark place for 5 minutes: the color of the solution does not change, and no turbidity is produced.

(10) Fatty acids and esters—Mix 50 g of Glycerin with 50 mL of freshly boiled and cooled water, add exactly 10 mL of 0.1 mol/L sodium hydroxide VS, boil the mixture for 15 minutes, cool, and titrate <2.50> the excess sodium hydroxide with 0.1 mol/L hydrochloric acid VS: 0.1 mol/L sodium hydroxide VS consumed is not more than 3.0 mL (indicator: 3 drops of phenolphthalein TS). Perform a blank determination in the same manner.

(11) Ethylene glycol, diethylene glycol and related substances—Weigh accurately about 5.88 g of Glycerin, mix with methanol to make exactly 100 mL, and use this solution as the sample solution. Separately, weigh accurately about 0.1 g each of ethylene glycol and diethylene glycol, mix with methanol to make exactly 100 mL. Pipet 5 mL of this solution and transfer into a 100-mL volumetric flask. Separately, weigh 5.0 g of glycerin for gas chromatography, mix with a suitable amount of methanol and put in the volumetric flask, add methanol to make exactly 100 mL, and use this solution as the standard solution. Perform the test with exactly 1 μ L each of the sample solution and standard solution as directed under Gas Chromatography <2.02> according to the following conditions, and determine the peak areas, A_{T1} and A_{S1} , of ethylene glycol and, A_{T2} and A_{S2} , of diethylene glycol by the automatic integration method. The amounts of ethylene glycol and diethylene glycol, calculated by the following equations, are not more than 0.1%, respectively. The amount of the peak other than glycerin, ethylene glycol and diethylene glycol obtained from the sample solution, calculated by the area percentage method, is not more than 0.1%, and the total amount of the peaks other than glycerin is not more than 1.0%.

$$\begin{aligned} \text{Amount (\%)} \text{ of ethylene glycol} \\ = M_{S1}/M_T \times A_{T1}/A_{S1} \times 5 \end{aligned}$$

$$\begin{aligned} \text{Amount (\%)} \text{ of diethylene glycol} \\ = M_{S2}/M_T \times A_{T2}/A_{S2} \times 5 \end{aligned}$$

M_{S1} : Amount (g) of ethylene glycol taken

M_{S2} : Amount (g) of diethylene glycol taken

M_T : Amount (g) of Glycerin taken

Operating conditions—

Detector: A hydrogen flame-ionization detector.

Column: A fused-silica column 0.32 mm in inside diameter and 30 m in length, coated the inner surface with 14% cyanopropylphenyl-86% dimethyl silicone polymer for gas chromatography 1 μ m in thickness.

Column temperature: Inject at a constant temperature of about 100°C, raise the temperature at the rate of 7.5°C per minute to 220°C, and maintain at a constant temperature of about 220°C.

Injection port temperature: A constant temperature of about 220°C.

Detector temperature: A constant temperature of about 250°C.

Carrier gas: Helium.

Flow rate: about 38 cm per second.

Split ratio: 1:20.

Time span of measurement: About 3 times as long as the retention time of glycerin, beginning after the solvent peak.

System suitability—

System performance: Mix 50 mg each of ethylene glycol, diethylene glycol and glycerin for gas chromatography with 100 mL of methanol. When the procedure is run with 1 μ L of this solution under the above operating conditions, ethylene glycol, diethylene glycol and glycerin are eluted in this order, and the resolution between the peaks of ethylene glycol and diethylene glycol is not less than 40, and between

the peaks of diethylene glycol and glycerin is not less than 10.

System repeatability: When the test is repeated 6 times with 1 μ L of the standard solution under the above operating conditions, the relative standard deviations of the peak area of ethylene glycol and diethylene glycol are not more than 10%, respectively.

(12) Readily carbonizable substances—To 5 mL of Glycerin add carefully 5 mL of sulfuric acid for readily carbonizable substances, mix gently at a temperature between 18°C and 20°C, and allow to stand for 1 hour between 15°C and 25°C: the solution has not more color than Matching Fluid H.

Water <2.48> 13 – 17% (0.1 g, volumetric titration, direct titration).

Residue on ignition <2.44> Weigh accurately about 10 g of Glycerin in a tared crucible, heat to boiling, and fire to burn immediately. After cooling, moisten the residue with 1 to 2 drops of sulfuric acid, and ignite cautiously to constant mass: the mass of the residue is not more than 0.01%.

Assay Weigh accurately about 0.2 g of Glycerin, transfer into a glass-stoppered flask, add 50 mL of water, mix, add exactly 50 mL of sodium periodate TS, shake, and allow to stand in a dark place at a room temperature for about 30 minutes. Add 10 mL of a mixture of water and ethylene glycol (1:1), allow to stand for about 20 minutes, add 100 mL of water, and titrate <2.50> with 0.1 mol/L sodium hydroxide VS (indicator: 2 drops of phenolphthalein TS). Perform a blank determination in the same manner, and make the necessary correction.

$$\begin{aligned} \text{Each mL of 0.1 mol/L sodium hydroxide VS} \\ = 9.209 \text{ mg of } \text{C}_3\text{H}_8\text{O}_3 \end{aligned}$$

Containers and storage Containers—Tight containers.

Concentrated Glycerin

Concentrated Glycerol

濃グリセリン

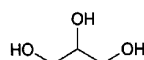

$\text{C}_3\text{H}_8\text{O}_3$: 92.09
Propane-1,2,3-triol
[56-81-5]

Concentrated Glycerin contains not less than 98.0% and not more than 101.0% of glycerin ($\text{C}_3\text{H}_8\text{O}_3$), calculated of the anhydrous basis.

Description Concentrated Glycerin is a clear, colorless and viscous liquid. It has a sweet taste.

It is miscible with water and with ethanol (99.5).

It is hygroscopic.

Identification Determine the infrared absorption spectrum of Concentrated Glycerin as directed in the liquid film method under Infrared Spectrophotometry <2.25>, and compare the spectrum with the Reference Spectrum: both spectra exhibit similar intensities of absorption at the same wave numbers.

Refractive index <2.45> n_D^{20} : Not less than 1.470.

Specific gravity <2.56> d_{20}^{20} : Not less than 1.258.

Purity (1) Color—Place 50 mL of Concentrated Glycerin in a Nessler tube, and observe downward: the solution has no more color than the following control solution.

Control solution: Pipet 0.40 mL of Iron (III) Chloride CS into a Nessler tube, and add water to make 50 mL.

(2) Acidity or alkalinity—To 2 mL of Concentrated Glycerin add 8 mL of water and mix: the solution is neutral.

(3) Chloride <1.03>—Take 10.0 g of Concentrated Glycerin, and perform the test. Prepare the control solution with 0.30 mL of 0.01 mol/L hydrochloric acid VS (not more than 0.001%).

(4) Sulfate <1.14>—Take 10.0 g of Concentrated Glycerin, and perform the test. Prepare the control solution with 0.40 mL of 0.005 mol/L sulfuric acid VS (not more than 0.002%).

(5) Ammonium—To 5 mL of Concentrated Glycerin add 5 mL of a solution of sodium hydroxide (1 in 10), and boil: the gas evolved does not change moistened red litmus paper to blue.

(6) Heavy metals <1.07>—Proceed with 5.0 g of Concentrated Glycerin according to Method 1, and perform the test. Prepare the control solution with 2.5 mL of Standard Lead Solution (not more than 5 ppm).

(7) Calcium—To 5 mL of the solution obtained in (2) add 3 drops of ammonium oxalate TS: the solution remains unchanged.

(8) Arsenic <1.11>—Prepare the test solution with 1.0 g of Concentrated Glycerin according to Method 1, and perform the test (not more than 2 ppm).

(9) Acrolein, glucose, or other reducing substances—To 1.0 g of Concentrated Glycerin add 1 mL of ammonia TS, mix, and warm in a water bath at 60°C for 5 minutes: no yellow color is produced. Take the solution out of the water bath, add 3 drops of silver nitrate TS immediately, and allow to stand in a dark place for 5 minutes: the color of the solution does not change, and no turbidity is produced.

(10) Fatty acids and esters—Mix 50 g of Concentrated Glycerin with 50 mL of freshly boiled and cooled water, add 10 mL of 0.1 mol/L sodium hydroxide VS, accurately measured, boil the mixture for 15 minutes, cool, and titrate <2.50> the excess sodium hydroxide with 0.1 mol/L hydrochloric acid VS: not more than 3.0 mL of 0.1 mol/L sodium hydroxide VS is consumed (indicator: 3 drops of phenolphthalein TS). Perform a blank determination in the same manner.

(11) Ethylene glycol, diethylene glycol and related substances—Weigh accurately about 5 g of Concentrated Glycerin, mix with methanol to make exactly 100 mL, and use this solution as the sample solution. Separately, weigh accurately about 0.1 g each of ethylene glycol and diethylene glycol, mix with methanol to make exactly 100 mL. Pipet 5 mL of this solution and transfer into a 100-mL volumetric flask. Separately, weigh 5.0 g of glycerin for gas chromatography, mix with a suitable amount of methanol and put in the volumetric flask, add methanol to make exactly 100 mL, and use this solution as the standard solution. Perform the test with exactly 1 μ L each of the sample solution and standard solution as directed under Gas Chromatography <2.02> according to the following conditions, and determine the peak areas, A_{T1} and A_{S1} , of ethylene glycol and, A_{T2} and A_{S2} , of diethylene glycol by the automatic integration method. The amounts of ethylene glycol and diethylene glycol, calculated by the following equations, are not more than 0.1%, respectively. The amount of the peak other than glycerin, ethylene glycol and diethylene glycol obtained from the sample solution, calculated by the area percentage method, is not more than 0.1%, and the total amount of the peaks other than glycerin is not more than 1.0%.

Amount (%) of ethylene glycol
 $= M_{S1}/M_T \times A_{T1}/A_{S1} \times 5$

Amount (%) of diethylene glycol
 $= M_{S2}/M_T \times A_{T2}/A_{S2} \times 5$

M_{S1} : Amount (g) of ethylene glycol taken

M_{S2} : Amount (g) of diethylene glycol taken

M_T : Amount (g) of Concentrated Glycerin taken

Operating conditions—

Detector: A hydrogen flame-ionization detector.

Column: A fused-silica column 0.32 mm in inside diameter and 30 m in length, coated the inner surface with 14% cyanopropylphenyl-86% dimethyl silicone polymer for gas chromatography 1 μ m in thickness.

Column temperature: Inject at a constant temperature of about 100°C, raise the temperature at the rate of 7.5°C per minute to 220°C, and maintain at a constant temperature of about 220°C.

Injection port temperature: A constant temperature of about 220°C.

Detector temperature: A constant temperature of about 250°C.

Carrier gas: Helium.

Flow rate: about 38 cm per second.

Split ratio: 1:20.

Time span of measurement: About 3 times as long as the retention time of glycerin, beginning after the solvent peak.

System suitability—

System performance: Mix 50 mg each of ethylene glycol, diethylene glycol and glycerin for gas chromatography with 100 mL of methanol. When the procedure is run with 1 μ L of this solution under the above operating conditions, ethylene glycol, diethylene glycol and glycerin are eluted in this order, and the resolution between the peaks of ethylene glycol and diethylene glycol is not less than 40, and between the peaks of diethylene glycol and glycerin is not less than 10.

System repeatability: When the test is repeated 6 times with 1 μ L of the standard solution under the above operating conditions, the relative standard deviations of the peak area of ethylene glycol and diethylene glycol are not more than 10%, respectively.

(12) Readily carbonizable substances—To 5 mL of Concentrated Glycerin add carefully 5 mL of sulfuric acid for readily carbonizable substances, mix gently at a temperature between 18°C and 20°C, and allow to stand for 1 hour between 15°C and 25°C: the solution has no more color than Matching Fluid H.

Water <2.48> Not more than 2.0% (6 g, volumetric titration, direct titration).

Residue on ignition <2.44> Weigh accurately about 10 g of Concentrated Glycerin in a tared crucible, heat to boiling, and fire to burn immediately. Cool, moisten the residue with 1 to 2 drops of sulfuric acid, and ignite cautiously to constant mass: the mass of the residue is not more than 0.01%.

Assay Weigh accurately about 0.2 g of Concentrated Glycerin, transfer into a glass-stoppered flask, add 50 mL of water, mix, add exactly 50 mL of sodium periodate TS, shake, and allow to stand in a dark place at a room temperature for about 30 minutes. Add 10 mL of a mixture of water and ethylene glycol (1:1), allow to stand for about 20 minutes, add 100 mL of water, and titrate <2.50> with 0.1 mol/L sodium hydroxide VS (indicator: 2 drops of phenolphthalein TS). Perform a blank determination in the same manner, and make the necessary correction.

Each mL of 0.1 mol/L sodium hydroxide VS
 $= 9.209$ mg of $C_3H_8O_3$

Containers and storage Containers—Tight containers.

Glycerin and Potash Solution

グリセリンカリ液

Method of preparation

Potassium Hydroxide	3 g
Glycerin	200 mL
Ethanol	250 mL
Aromatic substance	a suitable quantity
Water, Purified Water or Purified Water in Containers	a sufficient quantity
To make 1000 mL	

Dissolve Potassium Hydroxide in a portion of Water, Purified Water or Purified Water in Containers, add Glycerin, Ethanol, a suitable quantity of aromatic substance and another portion of Water, Purified Water or Purified Water in Containers to volume, and filter. Concentrated Glycerin may be used in place of Glycerin.

Description Glycerin and Potash Solution is a clear, colorless liquid, having an aromatic odor.

The pH of a solution of Glycerin and Potash Solution (1 in 5) is about 12.

Specific gravity d_{20}^{20} : about 1.02

Identification (1) A solution of Glycerin and Potash Solution (1 in 2) is alkaline (potassium hydroxide).

(2) Place 10 mL of a solution of Glycerin and Potash Solution (1 in 10) in a glass-stoppered test tube, add 2 mL of sodium hydroxide TS and 1 mL of copper (II) sulfate TS, and shake: a blue color is produced (glycerin).

(3) Glycerin and Potash Solution responds to Qualitative Tests <1.09> for potassium salt.

Containers and storage Containers—Tight containers.

Glyceryl Monostearate

モノステアリン酸グリセリン

Glyceryl Monostearate is a mixture of α - and β -glyceryl monostearate and other fatty acid esters of glycerin.

Description Glyceryl Monostearate occurs as white to light yellow, waxy masses, thin flakes, or granules. It has a characteristic odor and taste.

It is very soluble in hot ethanol (95), soluble in chloroform, sparingly soluble in diethyl ether, and practically insoluble in water and in ethanol (95).

It is slowly affected by light.

Identification (1) Heat 0.2 g of Glyceryl Monostearate with 0.5 g of potassium hydrogen sulfate until thoroughly charred: the irritative odor of acrolein is perceptible.

(2) Dissolve 0.1 g of Glyceryl Monostearate in 2 mL of ethanol (95) by warming, heat with 5 mL of dilute sulfuric acid in a water bath for 30 minutes, and cool: a white to yellow solid is produced. This separated solid dissolves when shaken with 3 mL of diethyl ether.

Melting point <1.13> Not below 55°C.

Acid value <1.13> Not more than 15.

Saponification value <1.13> 157 – 170

Iodine value <1.13> Not more than 3.0. Use chloroform instead of cyclohexane.

Purity <1.13> Acidity or alkalinity—To 1.0 g of Glyceryl Monostearate add 20 mL of boiling water, and cool with swirling: the solution is neutral.

Residue on ignition <2.44> Not more than 0.1% (1 g).

Containers and storage Containers—Tight containers.
Storage—Light-resistant.

Glycine

グリシン

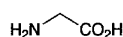

$\text{C}_2\text{H}_5\text{NO}_2$: 75.07
Aminoacetic acid
[56-40-6]

Glycine, when dried, contains not less than 98.5% of glycine ($\text{C}_2\text{H}_5\text{NO}_2$).

Description Glycine occurs as white, crystals or crystalline powder. It has a sweet taste.

It is freely soluble in water and in formic acid, and practically insoluble in ethanol (95).

It shows crystal polymorphism.

Identification Determine the infrared absorption spectrum of Glycine, previously dried, as directed in the potassium bromide disk method under Infrared Spectrophotometry <2.25>, and compare the spectrum with the Reference Spectrum: both spectra exhibit similar intensities of absorption at the same wave numbers. If any difference appears between the spectra, dissolve Glycine in water, evaporate the water to dryness, and repeat the test with the residue.

pH <2.54> Dissolve 1.0 g of Glycine in 20 mL of water: the pH of the solution is between 5.6 and 6.6.

Purity (1) Clarity and color of solution—Dissolve 1.0 g of Glycine in 10 mL of water: the solution is clear and colorless.

(2) Chloride <1.03>—Perform the test with 0.5 g of Glycine. Prepare the control solution with 0.30 mL of 0.01 mol/L hydrochloric acid VS (not more than 0.021%).

(3) Sulfate <1.14>—Perform the test with 0.6 g of Glycine. Prepare the control solution with 0.35 mL of 0.005 mol/L sulfuric acid VS (not more than 0.028%).

(4) Ammonium <1.02>—Perform the test using 0.25 g of Glycine. Prepare the control solution with 5.0 mL of Standard Ammonium Solution (not more than 0.02%).

(5) Heavy metals <1.07>—Proceed with 1.0 g of Glycine according to Method 1, and perform the test. Prepare the control solution with 2.0 mL of Standard Lead Solution (not more than 20 ppm).

(6) Arsenic <1.11>—Prepare the test solution with 1.0 g of Glycine according to Method 1, and perform the test (not more than 2 ppm).

(7) Related substances—Dissolve 0.10 g of Glycine in 25 mL of water and use this solution as the sample solution. Pipet 1 mL of the sample solution, add water to make ex-

actly 50 mL. Pipet 5 mL of this solution, add water to make exactly 20 mL, and use this solution as the standard solution. Perform the test with these solutions as directed under Thin-layer Chromatography <2.03>. Spot 5 μL each of the sample solution and standard solution on a plate of silica gel for thin-layer chromatography. Develop the plate with a mixture of 1-butanol, water and acetic acid (100) (3:1:1) to a distance of about 10 cm, and dry the plate at 80°C for 30 minutes. Spray evenly a solution of ninhydrin in acetone (1 in 50), and heat at 80°C for 5 minutes: the spots other than the principal spot from the sample solution are not more intense than the spot from the standard solution.

Loss on drying <2.41> Not more than 0.30% (1 g, 105°C, 3 hours).

Residue on ignition <2.44> Not more than 0.1% (1 g).

Assay Weigh accurately about 80 mg of Glycine, previously dried, dissolve in 3 mL of formic acid, add 50 mL of acetic acid (100), and titrate <2.50> with 0.1 mol/L perchloric acid VS (potentiometric titration). Perform a blank determination in the same manner, and make any necessary correction.

Each mL of 0.1 mol/L perchloric acid VS
= 7.507 mg of $\text{C}_2\text{H}_5\text{NO}_2$

Containers and storage Containers—Well-closed containers.

Gonadorelin Acetate

ゴナドレリン酢酸塩

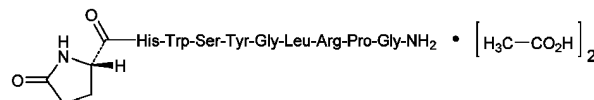

$\text{C}_{55}\text{H}_{75}\text{N}_{17}\text{O}_{13} \cdot 2\text{C}_2\text{H}_4\text{O}_2$: 1302.39

5-Oxo-L-prolyl-L-histidyl-L-tryptophyl-L-seryl-L-tyrosyl-glycyl-L-leucyl-L-arginyl-L-prolyl-glycinamide diacetate
[34973-08-5]

Gonadorelin Acetate contains not less than 96.0% and not more than 102.0% of gonadorelin acetate ($\text{C}_{55}\text{H}_{75}\text{N}_{17}\text{O}_{13} \cdot 2\text{C}_2\text{H}_4\text{O}_2$), calculated on the anhydrous basis.

Description Gonadorelin Acetate occurs as a white to pale yellow powder. It is odorless or has a slight, acetic odor.

It is freely soluble in water, in methanol and in acetic acid (100), and sparingly soluble in ethanol (95).

It is hygroscopic.

Identification (1) Determine the absorption spectrum of a solution of Gonadorelin Acetate in methanol (1 in 10,000) as directed under Ultraviolet-visible Spectrophotometry <2.24>, and compare the spectrum with the Reference Spectrum: both spectra exhibit similar intensities of absorption at the same wavelengths.

(2) Determine the infrared absorption spectrum of Gonadorelin Acetate as directed in the potassium bromide disk method under Infrared Spectrophotometry <2.25>, and compare the spectrum with the Reference Spectrum or the spectrum of Gonadorelin Acetate RS: both spectra exhibit similar intensities of absorption at the same wave numbers.

(3) Dissolve 20 mg of Gonadorelin Acetate in 0.5 mL of

ethanol (99.5), add 1 mL of sulfuric acid, and heat: the odor of ethyl acetate is perceptible.

Optical rotation <2.49> $[\alpha]_D^{20}$: -53.0 – -57.0° (0.1 g calculated on the anhydrous basis, diluted acetic acid (100) (1 in 100), 10 mL, 100 mm).

pH <2.54> Dissolve 0.10 g of Gonadorelin Acetate in 10 mL of water: the pH of this solution is between 4.8 and 5.8.

Constituent amino acids Put 10 mg of Gonadorelin Acetate in a test tube for hydrolysis, add 0.5 mL of hydrochloric acid and 0.5 mL of a solution of mercaptoacetic acid (2 in 25), seal the tube under reduced pressure, and heat at 110°C for 5 hours. After cooling, open the tube, transfer the hydrolyzate into a beaker, and evaporate to dryness on a water bath. Add exactly 100 mL of 0.02 mol/L hydrochloric acid TS to dissolve the residue, and use this solution as the sample solution. Separately, weigh exactly 0.105 g of L-serine, 0.147 g of L-glutamic acid, 0.115 g of L-proline, 75 mg of glycine, 0.131 g of L-leucine, 0.181 g of L-tyrosine, 0.210 g of L-histidine hydrochloride monohydrate, 0.204 g of L-tryptophan and 0.211 g of L-arginine hydrochloride, which are all previously dried at 105°C for 3 hours, add 50 mL of 1 mol/L hydrochloric acid TS to dissolve them, and add water to make exactly 1000 mL. Pipet 10 mL of this solution, add 0.02 mol/L hydrochloric acid TS to make exactly 200 mL, and use this solution as the standard solution. Perform the test with 50 μL each of the sample solution and standard solution as directed under Liquid Chromatography <2.01> according to the following conditions: the peaks of nine constituent amino acids are observed on the chromatogram obtained from the sample solution, and their respective molar ratios to arginine are 0.7 – 1.0 for serine and tryptophan, 0.8 – 1.2 for proline, 0.9 – 1.1 for glutamic acid, leucine, tyrosine and histidine, respectively, and 1.8 – 2.2 for glycine.

Operating conditions—

Detector: A visible spectrophotometer (wavelength: 440 nm for proline and 570 nm for others).

Column: A stainless steel column 4 mm in inside diameter and 8 cm in length, packed with strongly acidic ion-exchange resin for liquid chromatography composed with a sulfonated polystyrene copolymer (5 μm in particle diameter).

Column temperature: A constant temperature of about 57°C .

Chemical reaction bath temperature: A constant temperature of about 130°C .

Mobile phase: Prepare the mobile phases A, B, C and D according to the following table.

Mobile phase	A	B	C	D
Trisodium citrate dihydrate	6.19 g	7.74 g	26.67 g	—
Sodium hydroxide	—	—	—	8.00 g
Sodium chloride	5.66 g	7.07 g	54.35 g	—
Citric acid monohydrate	19.80 g	22.00 g	6.10 g	—
Ethanol (99.5)	130 mL	20 mL	—	100 mL
Benzyl alcohol	—	—	5 mL	—
Thiodiglycol	5 mL	5 mL	—	—
Lauromacrogol solution in diethyl ether (1 in 4)	4 mL	4 mL	4 mL	4 mL
Caprylic acid	0.1 mL	0.1 mL	0.1 mL	0.1 mL
Water	a sufficient amount	a sufficient amount	a sufficient amount	a sufficient amount
Total volume	1000 mL	1000 mL	1000 mL	1000 mL

Flowing of mobile phase: Control the gradient by mixing the mobile phases A, B, C and D as directed in the following table.

Time after injection of sample (min)	Mobile phase A (vol%)	Mobile phase B (vol%)	Mobile phase C (vol%)	Mobile phase D (vol%)
0 ~ 9	100	0	0	0
9 ~ 25	0	100	0	0
25 ~ 61	0	100 → 0	0 → 100	0
61 ~ 76	0	0	100	0
76 ~ 96	0	0	0	100

Reaction reagent: Dissolve 204 g of lithium acetate dihydrate in 336 mL of water, add 123 mL of acetic acid (100) and 401 mL of 1-methoxy-2-propanol, and use as Solution A. Separately, dissolve 39 g of ninhydrin and 81 mg of sodium borohydride in 979 mL of 1-methoxy-2-propanol, and use as Solution B. Mix the same volume of Solution A and Solution B before use.

Flow rate of mobile phase: 0.25 mL per minute.

Flow rate of reaction reagent: 0.3 mL per minute.

System suitability—

System performance: When the procedure is run with 50 μL of the standard solution under the above operating conditions, serine, glutamic acid, proline, glycine, leucine, tyrosine, histidine, tryptophan and arginine are eluted in this order with enough separation between these peaks.

Purity (1) Clarity and color of solution—A solution obtained by dissolving 0.10 g of Gonadorelin Acetate in 10 mL of water is clear, and the absorbance of this solution at 350 nm determined as directed under Ultraviolet-visible Spectrophotometry <2.24> is not more than 0.10.

(2) Related substances—Dissolve 50 mg of Gonadorelin Acetate in 100 mL of the mobile phase, and use this solution as the sample solution. Pipet 1 mL of the sample solution, add the mobile phase to make exactly 20 mL, and use this solution as the standard solution. Perform the test with exactly 10 μL each of the sample solution and standard solution as directed under Liquid Chromatography <2.01> according to the following conditions, and determine each peak area by the automatic integration method: the area of the peak other than gonadorelin from the sample solution is not larger than 1/5 times the peak area of gonadorelin from the standard solution, and the total area of the peaks other than gonadorelin from the sample solution is not larger than 3/5 times the peak area of gonadorelin from the standard solution.

Operating conditions—

Detector, column, column temperature, mobile phase, and flow rate: Proceed as directed in the operating conditions in the Assay.

Time span of measurement: About 2.5 times as long as the retention time of gonadorelin, beginning after the solvent peak.

System suitability—

Test for required detectability: To exactly 2 mL of the standard solution add the mobile phase to make exactly 100 mL. Confirm that the peak area of gonadorelin obtained with 10 μL of this solution is equivalent to 1 to 3% of that with 10 μL of the standard solution.

System performance: Dissolve 4 mg of Gonadorelin Acetate in a suitable amount of the mobile phase, add 5 mL of a solution of phenacetin in acetonitrile (1 in 1000) and the mobile phase to make 50 mL. When the procedure is run with 10 μL of this solution under the above operating conditions, gonadorelin and phenacetin are eluted in this order with the resolution between these peaks being not less than 3.

System repeatability: When the test is repeated 6 times with 10 μL of the standard solution under the above operat-

ing conditions, the relative standard deviation of the peak area of gonadorelin is not more than 5%.

Water <2.48> Not more than 8.0% (0.15 g, volumetric titration, direct titration).

Residue on ignition <2.44> Not more than 0.2% (0.1 g).

Assay Weigh accurately about 20 mg of Gonadorelin Acetate and Gonadorelin Acetate RS (separately determine the water <2.48> in the same manner as Gonadorelin Acetate) and dissolve in diluted acetic acid (100) (1 in 1000) to make exactly 25 mL each. Pipet 5 mL each of these solutions, add exactly 5 mL of the internal standard solution and add water to make 25 mL, and use these solutions as the sample solution and standard solution. Perform the test with 10 μ L each of the sample solution and standard solution as directed under Liquid Chromatography <2.01> according to the following conditions, and calculate the ratios, Q_T and Q_S , of the peak area of gonadorelin to that of the internal standard.

$$\begin{aligned} & \text{Amount (mg) of gonadorelin acetate} \\ & (\text{C}_{55}\text{H}_{75}\text{N}_{17}\text{O}_{13}\cdot 2\text{C}_2\text{H}_4\text{O}_2) \\ & = M_S \times Q_T/Q_S \end{aligned}$$

M_S : Amount (mg) of Gonadorelin Acetate RS taken, calculated on the anhydrous basis

Internal standard solution—A solution of phenacetin in a mixture of water and acetonitrile (3:2) (1 in 1000).

Operating conditions—

Detector: An ultraviolet absorption photometer (wavelength: 220 nm).

Column: A stainless steel column 4.6 mm in inside diameter and 15 cm in length, packed with octadecylsilanized silica gel for liquid chromatography (5 μ m in particle diameter).

Column temperature: A constant temperature of about 40°C.

Mobile phase: A mixture of 0.05 mol/L potassium dihydrogen phosphate TS (pH 3.0) and acetonitrile (90:17).

Flow rate: Adjust so that the retention time of gonadorelin is about 13 minutes.

System suitability—

System performance: When the procedure is run with 10 μ L of the standard solution under the above operating conditions, gonadorelin and the internal standard are eluted in this order with the resolution between these peaks being not less than 3.

System repeatability: When the test is repeated 6 times with 10 μ L of the standard solution under the above operating conditions, the relative standard deviation of the ratio of the peak area of gonadorelin to that of the internal standard is not more than 1.5%.

Containers and storage Containers—Tight containers.

Storage—Light-resistant.

Human Chorionic Gonadotrophin

Chorionic Gonadotrophin

ヒト絨毛性性腺刺激ホルモン

Human Chorionic Gonadotrophin is a dried preparation of gonad-stimulating hormone obtained from the urine of healthy pregnant women after the manufacturing process to remove or inactivate the virus.

It contains not less than 2500 human chorionic

gonadotrophin Units per mg, and contains not less than 3000 chorionic gonadotrophin Units per mg protein.

It contains not less than 80% and not more than 125% of the labeled human chorionic gonadotrophin Units.

Description Human Chorionic Gonadotrophin occurs as a white to light yellow-brown powder.

It is freely soluble in water.

Identification Calculate b by the following equation, using Y_3 and Y_4 obtained in the Assay: b is not more than 120.

$$b = E/I$$

$$E = (Y_3 - Y_4)/f$$

f : Number of test animals per group

$$I = \log (T_H/T_L)$$

Purity (1) Clarity and color of solution—Dissolve 0.05 g of Human Chorionic Gonadotrophin in 5 mL of isotonic sodium chloride solution: the solution is clear and colorless or light yellow.

(2) Estrogen—Inject subcutaneously into each of three female albino rats or albino mice ovariectomized at least two weeks before the test, single dose of 100 units according to the labeled Units dissolved in 0.5 mL of isotonic sodium chloride solution. Take vaginal smear twice daily, on the third, fourth and fifth day. Place the smear thinly on a slide glass, dry, stain with Giemsa's TS, wash with water, and again dry: no estrus figure is shown microscopically.

Loss on drying <2.41> Not more than 5.0% (0.1 g, in vacuum, phosphorus (V) oxide, 4 hours).

Bacterial endotoxins <4.01> Less than 0.03 EU/unit.

Abnormal toxicity Dilute Human Chorionic Gonadotrophin with isotonic sodium chloride solution so that each mL of the solution contains 120 Units, and use this solution as the sample solution. Inject 5.0 mL of the sample solution into the peritoneal cavity of each of 2 or more of well-nourished, healthy guinea pigs weighing about 350 g, and observe the conditions of the animals for more than 7 days: all the animals exhibit no abnormalities.

Specific activity When calculate from the results obtained by the Assay and the following test, the specific activity is not less than 3000 human chorionic gonadotrophin Units per mg protein.

(i) **Sample solution**—To an exactly amount of Human Chorionic Gonadotrophin add water to make a solution so that each mL contains about 500 Units of human chorionic gonadotrophin.

(ii) **Standard solution**—Weigh accurately about 10 mg of bovine serum albumin, and dissolve in water to make exactly 20 mL. To a suitable volume of this solution add water to make four solutions containing exactly 300, 200, 100 and 50 μ g of the albumin per mL, respectively.

(iii) **Procedure**—Pipet 0.5 mL each of the sample solution and standard solutions, put them in glass test tubes about 18 mm in inside diameter and about 130 mm in length, add exactly 5 mL of alkaline copper TS, mix, and allow the tubes to stand in a water bath at 30°C for 10 minutes. Then add exactly 0.5 mL of diluted Folin's TS (1 in 2), mix, and warm in a water bath at 30°C for 20 minutes. Determine the absorbances of these solutions at 750 nm as directed under Ultraviolet-visible Spectrophotometry <2.24> using a solution obtained in the same manner with 0.5 mL of water as the

blank.

Plot the absorbances of the standard solutions on the vertical axis and their protein concentrations on the horizontal axis to prepare a calibration curve, and determine the protein content of the sample solution from its absorbance by using this curve. Then calculate the amount of the protein in the sample.

Assay (i) Test animals—Select healthy female albino rats weighing about 45 to 65 g.

(ii) Standard solution—Dissolve a quantity of Human Chorionic Gonadotrophin RS in bovine serum albumin-isotonic sodium chloride solution to prepare four kinds of solutions, having 7.5, 15, 30 and 60 Units per 2.5 mL, respectively. Inject these solutions into four groups consisting of five test animals each, and weigh their ovaries, as directed in procedure of (iv). Inject bovine serum albumin-isotonic sodium chloride solution to another group, and use this group as the control group. According to the result of this test, designate the concentration of the reference standard which will increase the masses of the ovaries about 2.5 times the mass of the ovaries of the control group as a low-dose concentration of the standard solution, and the concentration 1.5 to 2.0 times the low-dose concentration as a high-dose concentration. Dissolve a quantity of Human Chorionic Gonadotrophin RS, in bovine serum albumin-isotonic sodium chloride solution, and prepare a high-dose standard solution S_H and a low-dose standard solution S_L whose concentrations are equal to those determined by the above test.

(iii) Sample solution—According to the labeled units, weigh accurately a suitable quantity of Human Chorionic Gonadotrophin, dissolve in bovine serum albumin-isotonic sodium chloride solution, and prepare a high-dose sample solution T_H and a low-dose sample solution T_L having Units equal to the standard solutions in equal volumes.

(iv) Procedure—Divide the test animals at random into 4 groups, A, B, C and D, with not less than 10 animals and equal numbers in each group. Inject subcutaneously 0.5 mL of S_H , S_L , T_H and T_L in each group for 5 days. On the sixth day, excise the ovaries, remove the fat and other unwonted tissues attached to the ovaries, and remove the adhering water by lightly pressing between filter paper, and immediately weigh the ovaries.

(v) Calculation—Designate the mass of ovaries by S_H , S_L , T_H and T_L as y_1 , y_2 , y_3 and y_4 , respectively. Sum up y_1 , y_2 , y_3 and y_4 on each set to obtain Y_1 , Y_2 , Y_3 and Y_4 .

Units per mg of Human Chorionic Gonadotrophin
= $\text{antilog } M \times \text{units per mL of } S_H \times b/a$

$$M = IY_a/Y_b$$

$$I = \log (S_H/S_L) = \log (T_H/T_L)$$

$$Y_a = -Y_1 - Y_2 + Y_3 + Y_4$$

$$Y_b = Y_1 - Y_2 + Y_3 - Y_4$$

a : Mass (mg) of Human Chorionic Gonadotrophin taken

b : Total volume (mL) of the high dose of the test solution prepared by diluting with bovine serum albumin-isotonic sodium chloride solution

F' computed by the following equation should be smaller than F_1 against n when s^2 is calculated. And compute L ($P = 0.95$) by the following equation: L should be not more than 0.3. If F' exceeds F_1 , or if L exceeds 0.3, repeat the test increasing the number of the test animals or arranging the assay method in a better way until F' is smaller than F_1 or L is not more than 0.3.

$$F' = (Y_1 - Y_2 - Y_3 + Y_4)^2 / (4fs^2)$$

f : Number of test animals per group

$$s^2 = \{\Sigma y^2 - (Y/f)\} / n$$

Σy^2 : The sum of the squares of each y_1 , y_2 , y_3 and y_4

$$Y = Y_1^2 + Y_2^2 + Y_3^2 + Y_4^2$$

$$n = 4(f - 1)$$

$$L = 2\sqrt{(C - 1)(CM^2 + I^2)}$$

$$C = Y_b^2 / (Y_b^2 - 4fs^2t^2)$$

t^2 : Value shown in the following table against n used to calculate s^2

n	$t^2 = F_1$	n	$t^2 = F_1$	n	$t^2 = F_1$
1	161.45	13	4.667	25	4.242
2	18.51	14	4.600	26	4.225
3	10.129	15	4.543	27	4.210
4	7.709	16	4.494	28	4.196
5	6.608	17	4.451	29	4.183
6	5.987	18	4.414	30	4.171
7	5.591	19	4.381	40	4.085
8	5.318	20	4.351	60	4.001
9	5.117	21	4.325	120	3.920
10	4.965	22	4.301	∞	3.841
11	4.844	23	4.279		
12	4.747	24	4.260		

Containers and storage Containers—Tight containers.
Storage—Light-resistant, and in a cold place.

Human Chorionic Gonadotrophin for Injection

Chorionic Gonadotrophin for Injection

注射用ヒト絨毛性性腺刺激ホルモン

Human Chorionic Gonadotrophin for Injection is a preparation for injection which is dissolved before use.

It contains not less than 80% and not more than 125% of the labeled human chorionic gonadotrophin Units.

Method of preparation Prepare as directed under Injections with Human Chorionic Gonadotrophin.

Description Human Chorionic Gonadotrophin for Injection occurs as a white to light yellow-brown powder or masses.

Identification Proceed as directed in the Identification under Human Chorionic Gonadotrophin.

pH <2.54> Prepare a solution so that each mL of isotonic sodium chloride solution contains 2 mg of Human Chorionic Gonadotrophin for Injection: the pH of this solution is between 5.0 and 7.0.

Loss on drying <2.41> Not more than 5.0% (0.1 g, in vacuum, phosphorus (V) oxide, 4 hours).

Bacterial endotoxins <4.01> Less than 0.03 EU/unit.

Uniformity of dosage units <6.02> It meets the requirement of the Mass variation test, when calculate the acceptance

value using the mean of estimated contents of the units tested as M .

Foreign insoluble matter <6.06> Perform the test according to the Method 2: it meets the requirement.

Insoluble particulate matter <6.07> It meets the requirement.

Sterility <4.06> Perform the test according to the Membrane filtration method: it meets the requirement.

Assay Proceed as directed in the Assay under Human Chorionic Gonadotrophin. The ratio of the assayed Units to the labeled Units should be calculated by the following equation.

$$\frac{\text{The ratio of the assayed Units to the labeled Units}}{\text{= antilog } M}$$

Containers and storage Containers—Hermetic containers. Storage—Light-resistant, and in a cold place.

Human Menopausal Gonadotrophin

ヒト下垂体性腺刺激ホルモン

Human Menopausal Gonadotrophin is a dried preparation of gonad-stimulating hormone obtained from the urine of postmenopausal healthy women, after processing for virus removal or inactivation. It has follicle-stimulating hormonal action and luteinizing hormonal action.

It contains not less than 40 follicle-stimulating hormone Units per mg.

Description Human Menopausal Gonadotrophin occurs as a white to pale yellow powder.

It is soluble in water.

Ratio of interstitial cell-stimulating hormone to follicle-stimulating hormone Perform the test according to the following method: the ratio of the unit of interstitial cell-stimulating hormone (luteinizing hormone) to that of follicle-stimulating hormone is not more than 1.

(i) Test animals—Select healthy male albino rats weighing about 45 to 65 g.

(ii) Standard solutions—Dissolve Menopausal Gonadotrophin RS in bovine serum albumin-sodium chloride-phosphate buffer solution (pH 7.2) to prepare three kinds of solutions, containing 10, 20 and 40 interstitial cell-stimulating hormone (luteinizing hormone) units per 1.0 mL, respectively. Inject these solutions into three groups consisting of five test animals each, and weigh their seminal vesicles as directed in (iv). According to the result of the test, designate the concentration of the reference standard, which will make the mass of the seminal vesicle 20 to 35 mg, as the high-dose standard solution, S_H . Dilute the S_H to 1.5 to 2.0 times the initial volume with the bovine serum albumin-sodium chloride-phosphate buffer solution (pH 7.2) and designate this solution as the low-dose standard solution, S_L .

(iii) Sample solutions—Weigh accurately a suitable amount of Human Menopausal Gonadotrophin, and dissolve in the bovine serum albumin-sodium chloride-phosphate buffer solution (pH 7.2) to prepare the high-dose sample solution, T_H and the low-dose sample solution, T_L , so that their concentrations are similar to those of the corresponding standard solutions, respectively. Store these solutions at 2–8°C.

(iv) Procedure—Divide the test animals at random into 4 groups, A, B, C and D, with not less than 10 animals and equal numbers in each group. Inject subcutaneously once every day 0.2 mL each of S_H , S_L , T_H and T_L to each animal in the respective groups for five days. On the sixth day, excise the seminal vesicles, remove extraneous tissue, remove fluid adhering to the vesicles and the contents of the vesicles by lightly pressing between filter papers, and weigh the vesicles.

(v) Calculation—Proceed as directed in (v) in the Assay by changing the mass of ovaries to the mass of seminal vesicles and the unit of follicle-stimulating hormone to the unit of interstitial cell-stimulating hormone to read.

Water <2.48> Not more than 5.0% (0.2 g, volumetric titration, direct titration).

Bacterial endotoxins <4.01> Dissolve Human Menopausal Gonadotrophin in water for bacterial endotoxins test to prepare a solution containing 75 follicle-stimulating hormone Units per mL, and perform the test: less than 0.66 EU/follicle-stimulating hormone Unit.

Specific activity Perform the test with Human Menopausal Gonadotrophin according to the following method, and calculate the specific activity using the amount (Unit) obtained in the Assay: it is not less than 50 follicle-stimulating hormone Units per 1 mg of protein.

(i) Sample solution—Weigh accurately about 10 mg of Human Menopausal Gonadotrophin, dissolve in water so that each mL contains exactly 200 μ g, and use this solution as the sample solution.

(ii) Standard solutions—Weigh accurately about 10 mg of bovine serum albumin, and dissolve in water to make exactly 20 mL. To this solution add water to make four solutions containing exactly 300 μ g, 200 μ g, 100 μ g and 50 μ g of the albumin per mL, respectively, and use these solutions as the standard solutions.

(iii) Procedure—To glass test tubes, about 18 mm in inside diameter and about 130 mm in height, add separately exactly 0.5 mL each of the sample solution and the standard solutions. To these tubes add exactly 5 mL of alkaline copper TS, warm in a water bath at 30°C for 10 minutes, then add exactly 0.5 mL of diluted Folin's TS (1 in 2), and warm in a water bath at 30°C for 20 minutes. Perform the test with these solutions as directed under Ultraviolet-visible Spectrometry <2.24>, and determine the absorbances at 750 nm, using a liquid obtained with 0.5 mL of water in the same manner as above as a blank.

Prepare a calibration curve from the absorbances of the standard solutions, with absorbance on the vertical axis and concentration on the horizontal axis. Calculate the amount of protein in the sample solution from the absorbance of the sample solution using the curve, and calculate the protein content of the sample.

Assay

(i) Test animals—Select healthy female albino rats weighing about 45 to 65 g.

(ii) Standard solutions—Dissolve Human Menopausal Gonadotrophin RS in human chorionic gonadotrophin TS to prepare three solutions which contain 0.75, 1.5 and 3.0 follicle-stimulating hormone Units per 1.0 mL, respectively. Inject these solutions into three groups consisting of five test animals each, and weigh their ovaries, as directed in (iv). According to the result of the test, designate the concentration of the reference standard, which will make the mass of the ovary about 120 to 160 mg, as the high-dose standard solution, S_H . Dilute the S_H to 1.5 to 2.0 times the initial volume

with the human chorionic gonadotrophin TS, and designate the solution as the low-dose standard solution, S_L .

(iii) Sample solutions—Weigh accurately a suitable amount of Human Menopausal Gonadotrophin, dissolve in human chorionic gonadotrophin TS, and prepare the high-dose sample solution, T_H , and the low-dose sample solution, T_L , which have similar numbers of units to those of corresponding standard solutions in equal volume, respectively.

(iv) Procedure—Divide the test animals at random into 4 groups, A, B, C and D, with not less than 10 animals and equal numbers in each group. Inject subcutaneously 0.2 mL each of S_H , S_L , T_H and T_L into the animals in each group, once in the afternoon on the first day, three times in the morning, noon and afternoon on the second day, and two times in the morning and afternoon on the third day. On the fifth day, excise the ovaries, remove the fat and extraneous tissue, remove fluid adhering to the ovaries by lightly pressing between filter papers, and immediately weigh the ovaries.

(v) Calculation—Designate the mass of ovaries by S_H , S_L , T_H and T_L as y_1 , y_2 , y_3 and y_4 , respectively. Sum up y_1 , y_2 , y_3 and y_4 on each set to obtain Y_1 , Y_2 , Y_3 and Y_4 .

Units of follicle-stimulating hormone per mg of Human Menopausal Gonadotrophin

$$= \text{antilog } M \times (\text{units per mL of } S_H) \times b/a$$

$$M = IY_a/Y_b$$

$$I = \log (S_H/S_L) = \log (T_H/T_L)$$

$$Y_a = -Y_1 - Y_2 + Y_3 + Y_4$$

$$Y_b = Y_1 - Y_2 + Y_3 - Y_4$$

a : Mass (mg) of Human Menopausal Gonadotrophin taken

b : Total volume (mL) of the high dose of the test solution prepared by diluting with human chorionic gonadotrophin TS

F' computed by the following equation should be smaller than F_1 against n when s^2 is calculated. And compute L ($P = 0.95$) by the following equation: L should be not more than 0.3. If F' exceeds F_1 , or if L exceeds 0.3, repeat the test increasing the number of the test animals or arranging the assay method in a better way until F' is smaller than F_1 or L is not more than 0.3.

$$F' = (Y_1 - Y_2 - Y_3 + Y_4)^2 / (4fs^2)$$

f : Number of test animals per group

$$s^2 = \{\Sigma y^2 - (Y/f)\} / n$$

Σy^2 : The sum of the squares of each y_1 , y_2 , y_3 and y_4

$$Y = Y_1^2 + Y_2^2 + Y_3^2 + Y_4^2$$

$$n = 4(f - 1)$$

$$L = 2\sqrt{(C - 1)(CM^2 + I^2)}$$

$$C = Y_b^2 / (Y_a^2 - 4fs^2t^2)$$

t^2 : Value shown in the following table against n used to calculate s^2

n	$t^2 = F_1$	n	$t^2 = F_1$	n	$t^2 = F_1$
1	161.45	13	4.667	25	4.242
2	18.51	14	4.600	26	4.225
3	10.129	15	4.543	27	4.210
4	7.709	16	4.494	28	4.196
5	6.608	17	4.451	29	4.183
6	5.987	18	4.414	30	4.171
7	5.591	19	4.381	40	4.085
8	5.318	20	4.351	60	4.001
9	5.117	21	4.325	120	3.920
10	4.965	22	4.301	∞	3.841
11	4.844	23	4.279		
12	4.747	24	4.260		

Containers and storage Containers—Tight containers.

Storage—Light-resistant, and in a cold place.

Guaifenesin

グアイフェネシン

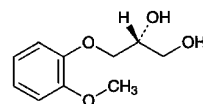

and enantiomer

$C_{10}H_{14}O_4$: 198.22

(2*R*,3*S*)-3-(2-Methoxyphenoxy)propane-1,2-diol
[93-14-1]

Guaifenesin, when dried, contains not less than 98.0% and not more than 102.0% of guaifenesin ($C_{10}H_{14}O_4$).

Description Guaifenesin occurs as white, crystals or crystalline powder.

It is freely soluble in ethanol (95), and sparingly soluble in water.

A solution of ethanol (95) (1 in 20) shows no optical rotation.

Identification (1) Determine the absorption spectrum of a solution of Guaifenesin (1 in 50,000) as directed under Ultraviolet-visible Spectrophotometry <2.24>, and compare the spectrum with the Reference Spectrum or the spectrum of a solution of Guaifenesin RS prepared in the same manner as the sample solution: both spectra exhibit similar intensities of absorption at the same wavelengths.

(2) Determine the infrared absorption spectrum of Guaifenesin, previously dried, as directed in the potassium bromide disk method under Infrared Spectrophotometry <2.25>, and compare the spectrum with the Reference Spectrum or the spectrum of previously dried Guaifenesin RS: both spectra exhibit similar intensities of absorption at the same wave numbers.

pH <2.54> Dissolve 1.0 g of Guaifenesin in 100 mL of water: the pH of the solution is between 5.0 and 7.0.

Melting point <2.60> 80 – 83°C

Purity (1) Clarity and color of solution—Dissolve 0.20 g of Guaifenesin in 10 mL of water: the solution is clear and colorless.

(2) Chloride <1.03>—Dissolve 0.7 g of Guaifenesin in 25 mL of water by warming. Cool, add 6 mL of dilute nitric acid and water to make 50 mL, and perform the test using

this solution as the test solution. Prepare the control solution with 0.40 mL of 0.01 mol/L hydrochloric acid VS (not more than 0.020%).

(3) Heavy metals <1.07>—Dissolve 2.0 g of Guaifenesin in 25 mL of water by warming. Cool, add 2 mL of dilute acetic acid and water to make 50 mL, and perform the test using this solution as the test solution. Prepare the control solution with 2.0 mL of Standard Lead Solution (not more than 10 ppm).

(4) Arsenic <1.11>—Prepare the test solution with 1.0 g of Guaifenesin according to Method 3, and perform the test (not more than 2 ppm).

(5) Free guaiacol—To 1.0 g of Guaifenesin add exactly 25 mL of water, dissolve by warming, cool, and use this solution as the sample solution. Separately, dissolve 0.100 g of guaiacol in water to make exactly 1000 mL. Pipet 3 mL of this solution, add exactly 22 mL of water, and use this solution as the standard solution. To each of the sample solution and standard solution add 1.0 mL of potassium hexacyanoferrate (III) TS and 5.0 mL of a solution of 4-aminoantipyrine (1 in 200), and immediately after shaking for exactly 5 seconds add a solution of sodium hydrogen carbonate (1 in 1200) to make exactly 100 mL. Determine the absorbances of these solutions at 500 nm exactly 15 minutes after the addition of the 4-aminoantipyrine solution as directed under Ultraviolet-visible Spectrophotometry <2.24>, using a solution, prepared in the same manner with 25 mL of water, as the blank: the absorbance of the solution obtained from the sample solution is not more than that from the standard solution.

(6) Related substances—Dissolve 1.0 g of Guaifenesin in 100 mL of ethanol (95), and use this solution as the sample solution. Pipet 1 mL of the sample solution, add water to make exactly 200 mL, and use this solution as the standard solution. Perform the test with these solutions as directed under Thin-layer Chromatography <2.03>. Spot 10 μ L each of the sample solution and standard solution on a plate of silica gel for thin-layer chromatography. Develop the plate with a mixture of diethyl ether, ethanol (95), and ammonia solution (28) (40:10:1) to a distance of about 10 cm, and air-dry the plate. Spray evenly 4-dimethylaminobenzaldehyde TS for spraying on the plate, and heat the plate at 110°C for 10 minutes: the spots other than the principal spot obtained from the sample solution are not more intense than the spot from the standard solution.

Loss on drying <2.41> Not more than 0.5% (1 g, in vacuum, 60°C, 3 hours).

Residue on ignition <2.44> Not more than 0.1% (1 g).

Assay Weigh accurately about 60 mg of Guaifenesin and Guaifenesin RS, previously dried, and dissolve each then in water to make exactly 100 mL. Pipet 5 mL of these solutions, and add water to make exactly 100 mL, and use these solutions as the sample solution and standard solution. Determine the absorbances, A_T and A_S , of the sample solution and standard solution at 273 nm as directed under Ultraviolet-visible Spectrophotometry <2.24>.

$$\text{Amount (mg) of guaifenesin (C}_{10}\text{H}_{14}\text{O}_4) = M_S \times A_T/A_S$$

M_S : Amount (mg) of Guaifenesin RS taken

Containers and storage Containers—Tight containers.

Guanabenz Acetate

グアナベンズ酢酸塩

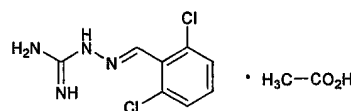

$\text{C}_8\text{H}_8\text{Cl}_2\text{N}_4 \cdot \text{C}_2\text{H}_4\text{O}_2$; 291.13

(*E*)-1-(2,6-Dichlorobenzylideneamino)guanidine monoacetate
[23256-50-0]

Guanabenz Acetate, when dried, contains not less than 98.5% of guanabenz acetate ($\text{C}_8\text{H}_8\text{Cl}_2\text{N}_4 \cdot \text{C}_2\text{H}_4\text{O}_2$).

Description Guanabenz Acetate occurs as white, crystals or crystalline powder.

It is freely soluble in acetic acid (100), soluble in methanol and in ethanol (95), slightly soluble in water, and practically insoluble in diethyl ether.

It is gradually affected by light.

Melting point: about 190°C (with decomposition).

Identification (1) To 5 mL of a solution of Guanabenz Acetate (1 in 1000) add 0.5 mL of a diluted ethanol (95) (5 in 6) which contains 16 g of urea and 0.2 g of 1-naphthol in 100 mL, and add 1 mL of *N*-bromosuccinimide TS: a purple color develops.

(2) Determine the absorption spectrum of a solution of Guanabenz Acetate in methanol (1 in 100,000) as directed under Ultraviolet-visible Spectrophotometry <2.24>, and compare the spectrum with the Reference Spectrum: both spectra exhibit similar intensities of absorption at the same wavelengths.

(3) Determine the infrared absorption spectrum of Guanabenz Acetate, previously dried, as directed in the potassium bromide disk method under Infrared Spectrophotometry <2.25>, and compare the spectrum with the Reference Spectrum: both spectra exhibit similar intensities of absorption at the same wave numbers.

(4) To 0.1 g of Guanabenz Acetate add 5 mL of water and 1 mL of ammonia TS, shake, filter, and neutralize the filtrate with dilute hydrochloric acid: the solution responds to Qualitative Tests <1.09> (3) for acetate.

Purity (1) Heavy metals <1.07>—Proceed with 2.0 g of Guanabenz Acetate according to Method 2, and perform the test. Prepare the control solution with 2.0 mL of Standard Lead Solution (not more than 10 ppm).

(2) Related substances—Conduct this procedure without exposure to light, using light-resistant vessels. Dissolve 0.05 g of Guanabenz Acetate in 5 mL of methanol, and use this solution as the sample solution. Pipet 1 mL of the sample solution, add methanol to make exactly 10 mL, then pipet 1 mL of this solution, add methanol to make exactly 20 mL, and use this solution as the standard solution. Perform the test with these solutions as directed under Thin-layer Chromatography <2.03>. Spot 5 μ L each of the sample solution and standard solution on a plate of silica gel with fluorescent indicator for thin-layer chromatography. Develop the plate with a mixture of chloroform, methanol and ammonia solution (28) (80:20:1) to a distance of about 10 cm, and air-dry the plate. Examine under ultraviolet light (main wavelength: 254 nm): the spots other than the principal spot obtained from the sample solution are not more intense than the spot from the standard solution. Place the plate in a

chamber filled with iodine vapor for 10 minutes: the spots other than the principal spot from the sample solution are not more intense than the spot from the standard solution.

Loss on drying <2.41> Not more than 0.5% (1 g, in vacuum, phosphorus (V) oxide, 50°C, 3 hours).

Residue on ignition <2.44> Not more than 0.2% (1 g).

Assay Weigh accurately about 0.25 g of Guanabenz Acetate, previously dried, dissolve in 50 mL of acetic acid (100), and titrate <2.50> with 0.1 mol/L perchloric acid VS (potentiometric titration). Perform a blank determination in the same manner, and make any necessary correction.

Each mL of 0.1 mol/L perchloric acid VS
= 29.11 mg of $C_8H_8Cl_2N_4 \cdot C_2H_4O_2$

Containers and storage Containers—Tight containers.

Storage—Light-resistant.

Guanethidine Sulfate

グアネチジン硫酸塩

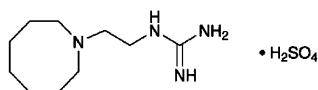

$C_{10}H_{22}N_4 \cdot H_2SO_4$: 296.39

1-[2-(Hexahydroazocin-1(2*H*)-yl)ethyl]guanidine monosulfate
[645-43-2]

Guanethidine Sulfate, when dried, contains not less than 98.5% of guanethidine sulfate ($C_{10}H_{22}N_4 \cdot H_2SO_4$).

Description Guanethidine Sulfate occurs as white, crystals or crystalline powder. It is odorless or has a slight, characteristic odor and a bitter taste.

It is very soluble in formic acid, freely soluble in water, and practically insoluble in ethanol (95) and in diethyl ether.

Melting point: 251 – 256°C (an evacuated sealed capillary tube, with decomposition).

Identification (1) To 4 mL of a solution of Guanethidine Sulfate (1 in 4000) add 2 mL of 1-naphthol TS, 1 mL of diacetyl TS and 15 mL of water, and allow to stand for 30 minutes: a red color develops.

(2) Determine the infrared absorption spectrum of Guanethidine Sulfate, previously dried, as directed in the potassium bromide disk method under Infrared Spectrophotometry <2.25>, and compare the spectrum with the Reference Spectrum: both spectra exhibit similar intensities of absorption at the same wave numbers.

(3) A solution of Guanethidine Sulfate (1 in 10) responds to Qualitative Tests <1.09> for sulfate.

pH <2.54> Dissolve 1.0 g of Guanethidine Sulfate in 50 mL of water: the pH of the solution is between 4.7 and 5.7.

Purity (1) Clarity and color of solution—Dissolve 1.0 g of Guanethidine Sulfate in 50 mL of water: the solution is clear and colorless.

(2) Methylisothiourea sulfate—Dissolve 2.0 g of Guanethidine Sulfate in 80 mL of sodium hydroxide TS, and allow to stand for 10 minutes. Add 60 mL of hydrochloric acid, 2 g of sodium bromide and water to make 200 mL. Then, to this solution add 0.70 mL of 1/60 mol/L potassium bromate VS and 2 mL of zinc iodide-starch TS: a blue color develops.

(3) Heavy metals <1.07>—Proceed with 2.0 g of Guanethidine Sulfate according to Method 4, and perform the test. Prepare the control solution with 2.0 mL of Standard Lead Solution (not more than 10 ppm).

Loss on drying <2.41> Not more than 0.5% (1 g, 105°C, 4 hours).

Residue on ignition <2.44> Not more than 0.2% (1 g).

Assay Weigh accurately about 0.5 g of Guanethidine Sulfate, previously dried, dissolve in 2 mL of formic acid, add 70 mL of a mixture of acetic anhydride and acetic acid (100) (6:1), and titrate <2.50> with 0.1 mol/L perchloric acid VS (potentiometric titration). Perform a blank determination in the same manner, and make any necessary correction.

Each mL of 0.1 mol/L perchloric acid VS
= 29.64 mg of $C_{10}H_{22}N_4 \cdot H_2SO_4$

Containers and storage Containers—Tight containers.

Storage—Light-resistant.

Freeze-dried Habu Antivenom, Equine

乾燥はぶウマ抗毒素

Freeze-dried Habu Antivenom, Equine, is a preparation for injection which is dissolved before use.

It contains *Trimeresurus flavoviridis* antivenom in immunoglobulin of horse origin.

It conforms to the requirements of Freeze-dried Habu Anti-venom, Equine, in the Minimum Requirements for Biological Products.

Description Freeze-dried Habu Antivenom, Equine, becomes colorless or light yellow-brown, clear liquid or a slightly white turbid liquid on addition of solvent.

Haloperidol

ハロペリドール

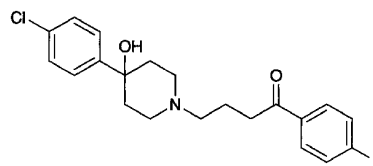

$C_{21}H_{23}ClFNO_2$: 375.86

4-[4-(4-Chlorophenyl)-4-hydroxypiperidin-1-yl]-1-(4-fluorophenyl)butan-1-one
[52-86-8]

Haloperidol, when dried, contains not less than 99.0% and not more than 101.0% of haloperidol ($C_{21}H_{23}ClFNO_2$).

Description Haloperidol occurs as white to pale yellow, crystals or powder.

It is freely soluble in acetic acid (100), sparingly soluble in methanol, slightly soluble in 2-propanol and in ethanol (99.5), and practically insoluble in water.

Identification (1) Dissolve 30 mg of Haloperidol in 100 mL of 2-propanol. To 5 mL of the solution add 10 mL of 0.1 mol/L hydrochloric acid TS and 2-propanol to make 100

mL. Determine the absorption spectrum of the solution as directed under Ultraviolet-visible Spectrophotometry <2.24>, and compare the spectrum with the Reference Spectrum: both spectra exhibit similar intensities of absorption at the same wavelengths.

(2) Determine the infrared absorption spectrum of Haloperidol as directed in the potassium bromide disk method under Infrared Spectrophotometry <2.25>, and compare the spectrum with the Reference Spectrum: both spectra exhibit similar intensities of absorption at the same wave numbers.

Melting point <2.60> 150 – 154°C

Purity (1) Sulfate <1.14>—To 1.0 g of Haloperidol add 50 mL of water, shake, and filter. To 25 mL of the filtrate add 1 mL of dilute hydrochloric acid and water to make 50 mL, and perform the test using this solution as the test solution. Prepare the control solution with 0.50 mL of 0.005 mol/L sulfuric acid VS (not more than 0.048%).

(2) Heavy metals <1.07>—Proceed with 1.0 g of Haloperidol according to method 2, and perform the test. Prepare the control solution with 2.0 mL of Standard Lead Solution (not more than 20 ppm).

(3) Related substances—Dissolve 25 mg of Haloperidol in 50 mL of the mobile phase, and use this solution as the sample solution. Pipet 1 mL of the sample solution, add the mobile phase to make exactly 200 mL, and use this solution as the standard solution. Perform the test with exactly 10 μ L each of the sample solution and standard solution as directed under Liquid Chromatography <2.01> according to the following conditions, and determine each peak area by the automatic integration method: the area of the peak other than haloperidol obtained from the sample solution is not larger than the peak area of haloperidol from the standard solution, and the total area of these peaks is not larger than 2 times the peak area of haloperidol from the standard solution. For the areas of the peaks, having the relative retention time of about 0.5, about 1.2 and about 2.6 to haloperidol, multiply their correction factors, 0.75, 1.47 and 0.76, respectively.

Operating conditions—

Detector: An ultraviolet absorption photometer (wavelength: 220 nm).

Column: A stainless steel column 4.6 mm in inside diameter and 15 cm in length, packed with octadecylsilanized silica gel for liquid chromatography (5 μ m in particle diameter).

Column temperature: A constant temperature of about 40°C.

Mobile phase: Dissolve 2.95 g of trisodium citrate dihydrate in 900 mL of water, adjust to pH 3.5 with dilute hydrochloric acid, and add water to make 1000 mL. To 300 mL of this solution add 700 mL of methanol and 1.0 g of sodium lauryl sulfate.

Flow rate: Adjust so that the retention time of haloperidol is about 9 minutes.

Time span of measurement: About 3 times as long as the retention time of haloperidol, beginning after the solvent peak.

System suitability—

Test for required detectability: To exactly 5 mL of the standard solution add the mobile phase to make exactly 25 mL. Confirm that the peak area of haloperidol obtained with 10 μ L of this solution is equivalent to 15 to 25% of that with 10 μ L of the standard solution.

System performance: When the procedure is run with 10 μ L of the standard solution under the above operating conditions, the number of theoretical plates and the symmetry factor of the peak of haloperidol are not less than 4000 and

not more than 2.0, respectively.

System repeatability: When the test is repeated 6 times with 10 μ L of the standard solution under the above operating conditions, the relative standard deviation of the peak area of haloperidol is not more than 2.0%.

Loss on drying <2.41> Not more than 0.5% (1 g, in vacuum, 60°C, phosphorus (V) oxide, 3 hours).

Residue on ignition <2.44> Not more than 0.1% (1 g).

Assay Weigh accurately about 0.6 g of haloperidol, previously dried, and dissolve in 40 mL of acetic acid (100), and titrate <2.50> with 0.1 mol/L perchloric acid VS (indicator: 1 drop of crystal violet TS). Perform a blank determination in the same manner.

Each mL of 0.1 mol/L perchloric acid VS
= 37.59 mg of C₂₁H₂₃ClFNO₂

Containers and storage Containers—Tight containers.

Storage—Light-resistant.

Haloperidol Fine Granules

ハロペリドール細粒

Haloperidol Fine Granules contain not less than 95.0% and not more than 105.0% of the labeled amount of haloperidol (C₂₁H₂₃ClFNO₂; 375.86).

Method of preparation Prepare as directed under Granules, with Haloperidol.

Identification Powder Haloperidol Fine Granules. To a portion of the powder, equivalent to 6 mg of Haloperidol, add 70 mL of 2-propanol, and heat to boiling on a water bath while shaking. After cooling, add 2-propanol to make 100 mL, and centrifuge. To 5 mL of the supernatant liquid add 2 mL of 0.1 mol/L hydrochloric acid TS and 2-propanol to make 20 mL. Determine the absorption spectrum of this solution as directed under Ultraviolet-visible Spectrophotometry <2.24>: it exhibits maxima between 219 nm and 223 nm and between 243 nm and 247 nm.

Dissolution <6.10> When the test is performed at 50 revolutions per minute according to the Paddle method, using 900 mL of water as the dissolution medium, the dissolution rate in 60 minutes of Haloperidol Fine Granules is not less than 70%.

Start the test with an accurately weighed amount of Haloperidol Fine Granules, equivalent to about 3 mg of haloperidol (C₂₁H₂₃ClFNO₂), withdraw not less than 20 mL of the medium at the specified minute after starting the test, and filter through a membrane filter with a pore size not exceeding 0.45 μ m. Discard not less than 10 mL of the first filtrate, pipet 5 mL of the subsequent filtrate, add water to make exactly 20 mL, and use this solution as the sample solution. Separately, weigh accurately about 17 mg of haloperidol for assay, previously dried in vacuum at 60°C for 3 hours using phosphorus (V) oxide as a desiccant, and dissolve in methanol to make exactly 200 mL. Pipet 2 mL of this solution, add water to make exactly 200 mL, and use this solution as the standard solution. Perform the test with exactly 100 μ L each of the sample solution and standard solution as directed under Liquid Chromatography <2.01>, and determine the peak areas, A_T and A_S, of haloperidol in each solution.

Dissolution rate (%) with respect to the labeled amount of haloperidol ($C_{21}H_{23}ClFNO_2$)

$$= M_S/M_T \times A_T/A_S \times 1/C \times 18$$

M_S : Amount (mg) of haloperidol for assay taken

M_T : Amount (g) of Haloperidol Fine Granules taken

C : Labeled amount (mg) of haloperidol ($C_{21}H_{23}ClFNO_2$) in 1 g

Operating conditions—

Column, column temperature, mobile phase, and flow rate: Proceed as detected in the operating conditions in the Assay.

Detector: An ultraviolet absorption photometer (wavelength: 245 nm).

System suitability—

System performance: When the procedure is run with 100 μ L of the standard solution under the above operating conditions, the number of theoretical plates and the symmetry factor of the peak of haloperidol are not less than 4000 and not more than 2.0, respectively.

System repeatability: When the test is repeated 6 times with 100 μ L of the standard solution under the above operating conditions, the relative standard deviation of the peak area of haloperidol is not more than 2.0%.

Assay Powder Haloperidol Fine Granules. Weigh accurately a portion of the powder, equivalent to about 10 mg of haloperidol ($C_{21}H_{23}ClFNO_2$), add 10 mL of water, disperse the particle by sonicating, add exactly 20 mL of the internal standard solution, sonicate, extract for 30 minutes with occasional shaking, and add the mobile phase to make 100 mL. Centrifuge after shaking for more 30 minutes, and use the supernatant liquid as the sample solution. Separately, weigh accurately about 25 mg of haloperidol for assay, previously dried in vacuum at 60°C for 3 hours on phosphorus (V) oxide, and dissolve in methanol to make exactly 25 mL. Pipet 10 mL of this solution, add exactly 20 mL of the internal standard solution and the mobile phase to make 100 mL, and use this solution as the standard solution. Perform the test with 10 μ L each of the sample solution and standard solution as directed under Liquid Chromatography <2.01> according to the following conditions, and calculate the ratios, Q_T and Q_S , of the peak area of haloperidol to that of the internal standard.

$$\begin{aligned} &\text{Amount (mg) of haloperidol (} C_{21}H_{23}ClFNO_2 \text{)} \\ &= M_S \times Q_T/Q_S \times 2/5 \end{aligned}$$

M_S : Amount (mg) of haloperidol for assay taken

Internal standard solution—A solution of diphenyl in methanol (1 in 2000).

Operating conditions—

Detector: An ultraviolet absorption photometer (wavelength: 220 nm).

Column: A stainless steel column 4.6 mm in inside diameter and 15 cm in length, packed with octadecylsilanized silica gel for liquid chromatography (5 μ m in particle diameter).

Column temperature: A constant temperature of about 40°C.

Mobile phase: Dissolve 2.95 g of trisodium citrate dihydrate in 900 mL of water, adjust to pH 3.5 with dilute hydrochloric acid, and add water to make 1000 mL. To 250 mL of this solution add 750 mL of methanol and 1.0 g of sodium lauryl sulfate, and mix to dissolve.

Flow rate: Adjust so that the retention time of haloperidol is about 9 minutes.

System suitability—

System performance: When the procedure is run with 10

μ L of the standard solution under the above operating conditions, haloperidol and diphenyl are eluted in this order with the resolution between these peaks being not less than 5.

System repeatability: When the test is repeated 6 times with 10 μ L of the standard solution under the above operating conditions, the relative standard deviation of the ratio of the peak area of haloperidol to that of the internal standard is not more than 1.0%.

Containers and storage Containers—Tight containers.

Storage—Light-resistant.

Haloperidol Injection

ハロペリドール注射液

Haloperidol Injection is an aqueous injection.

It contains not less than 95.0% and not more than 105.0% of the labeled amount of haloperidol ($C_{21}H_{23}ClFNO_2$; 375.86).

Method of preparation Prepare as directed under Injections, with Haloperidol.

Description Haloperidol Injection occurs as a colorless to pale yellow, clear liquid.

Identification To a volume of Haloperidol Injection, equivalent to 5 mg of Haloperidol, add 2-propanol to make 100 mL. To 5 mL of this solution add 2 mL of 0.1 mol/L hydrochloric acid TS and 2-propanol to make 20 mL. Determine the absorption spectrum of this solution as directed under Ultraviolet-visible Spectrophotometry <2.24>: it exhibits maxima between 219 nm and 223 nm and between 243 nm and 247 nm.

Osmotic pressure ratio Being specified separately when the drug is granted approval based on the Law.

pH Being specified separately when the drug is granted approval based on the Law.

Bacterial endotoxins <4.01> Less than 60 EU/mg.

Extractable volume <6.05> It meets the requirement.

Foreign insoluble matter <6.06> Perform the test according to Method 1: it meets the requirement.

Insoluble particulate matter <6.07> It meets the requirement.

Sterility <4.06> Perform the test according to the Membrane filtration method: it meets the requirement.

Assay Pipet a volume of Haloperidol Injection, equivalent to about 10 mg of haloperidol ($C_{21}H_{23}ClFNO_2$), add the mobile phase to make exactly 100 mL, and use this solution as the sample solution. Separately, weigh accurately about 25 mg of haloperidol for assay, previously dried in vacuum at 60°C using phosphorus (V) oxide as a desiccant for 3 hours, dissolve in methanol to make exactly 25 mL. Pipet 10 mL of this solution, add the mobile phase to make exactly 100 mL, and use this solution as the standard solution. Perform the test with exactly 10 μ L each of the sample solution and standard solution as directed under Liquid Chromatography <2.01> according to the following conditions, and determine the peak areas, A_T and A_S , of haloperidol in each solution.

$$\begin{aligned} &\text{Amount (mg) of haloperidol (} C_{21}H_{23}ClFNO_2 \text{)} \\ &= M_S \times A_T/A_S \times 2/5 \end{aligned}$$

M_S : Amount (mg) of haloperidol for assay taken

Operating conditions—

Detector: An ultraviolet absorption photometer (wavelength: 220 nm).

Column: A stainless steel column 4.6 mm in inside diameter and 15 cm in length, packed with octadecylsilanized silica gel for liquid chromatography (5 μ m in particle diameter).

Column temperature: A constant temperature of about 40°C.

Mobile phase: Dissolve 2.95 g of trisodium citrate dihydrate in 900 mL of water, adjust to pH 3.5 with dilute hydrochloric acid, and add water to make 1000 mL. To 250 mL of this solution add 750 mL of methanol, and add 1.0 g of sodium lauryl sulfate to dissolve.

Flow rate: Adjust so that the retention time of haloperidol is about 9 minutes.

System suitability—

System performance: When the procedure is run with 10 μ L of the standard solution under the above operating conditions, the number of theoretical plates and the symmetry factor of the peak of haloperidol are not less than 4000 and not more than 1.5, respectively.

System repeatability: When the test is repeated 6 times with 10 μ L of the standard solution under the above operating conditions, the relative standard deviation of the peak area of haloperidol is not more than 1.0%.

Containers and storage Containers—Hermetic containers. Colored containers may be used.

Storage—Light-resistant.

Haloperidol Tablets

ハロペリドール錠

Haloperidol Tablets contain not less than 93.0% and not more than 107.0% of the labeled amount of haloperidol ($C_{21}H_{23}ClFNO_2$; 375.86).

Method of preparation Prepare as directed under Tablets, with Haloperidol.

Identification To powdered Haloperidol Tablets, equivalent to 6 mg of Haloperidol, add 70 mL of 2-propanol, and heat on a water bath until to boiling while shaking. After cooling, add 2-propanol to make 100 mL, and centrifuge. To 5 mL of the supernatant liquid add 2 mL of 0.1 mol/L hydrochloric acid TS and 2-propanol to make 20 mL. Determine the absorption spectrum of the solution as directed under Ultraviolet-visible Spectrophotometry <2.24>: it exhibits maxima between 219 nm and 223 nm and between 243 nm and 247 nm.

Uniformity of dosage units <6.02> Perform the test according to the following method: it meets the requirement of the Content uniformity test.

To 1 tablet of Haloperidol Tablets add 5 mL of the mobile phase, disperse the particle by sonicating, add 30 mL of the mobile phase, sonicate, and extract for 30 minutes with occasional shaking. Shake for more 30 minutes, and add the mobile phase to make exactly 50 mL. Centrifuge the solution, pipet V mL of the supernatant liquid, equivalent to about 0.3 mg of haloperidol ($C_{21}H_{23}ClFNO_2$), add exactly 2 mL of the internal standard solution and the mobile phase to make 25 mL, and use this solution as the sample solution. Separately, weigh accurately about 20 mg of haloperidol for assay, previously dried in vacuum at 60°C for 3 hours on

phosphorus (V) oxide, and dissolve in the mobile phase to make exactly 100 mL. Pipet 15 mL of this solution, and add the mobile phase to make exactly 50 mL. Pipet 5 mL of this solution, add exactly 2 mL of the internal standard solution and the mobile phase to make 25 mL, and use this solution as the standard solution. Perform the test with 10 μ L each of the sample solution and standard solution as directed under Liquid Chromatography <2.01> according to the following conditions, and calculate the ratios, Q_T and Q_S , of the peak area of haloperidol to that of the internal standard.

$$\begin{aligned} &\text{Amount (mg) of haloperidol (C}_{21}\text{H}_{23}\text{ClFNO}_2\text{)} \\ &= M_S \times Q_T/Q_S \times 1/V \times 3/4 \end{aligned}$$

M_S : Amount (mg) of haloperidol for assay taken

Internal standard solution—A solution of diphenyl in the mobile phase (1 in 6700).

Operating conditions—

Proceed as detected in the operating condition in the Assay.

System suitability—

System performance: When the procedure is run with 10 μ L of the standard solution under the above operating conditions, haloperidol and diphenyl are eluted in this order with the resolution between these peaks being not less than 5.

System repeatability: When the test is repeated 6 times with 10 μ L of the standard solution under the above operating conditions, the relative standard deviation of the ratio of the peak area of haloperidol to that of the internal standard is not more than 1.0%.

Dissolution Being specified separately when the drug is granted approval based on the Law.

Assay Weigh accurately, and powder not less than 20 Haloperidol Tablets. Weigh accurately a portion of the powder, equivalent to about 10 mg of haloperidol ($C_{21}H_{23}ClFNO_2$), add 10 mL of water, disperse the particle by sonicating, add exactly 20 mL of the internal standard solution, sonicate, extract for 30 minutes with occasional shaking, and add the mobile phase to make 100 mL. Centrifuge after shaking for more 30 minutes, and use the supernatant liquid as the sample solution. Separately, weigh accurately about 25 mg of haloperidol for assay, previously dried in vacuum at 60°C for 3 hours on phosphorus (V) oxide, and dissolve in methanol to make exactly 25 mL. Pipet 10 mL of this solution, add exactly 20 mL of the internal standard solution and the mobile phase to make exactly 100 mL, and use this solution as the standard solution. Perform the test with 10 μ L each of the sample solution and standard solution as directed under Liquid Chromatography <2.01> according to the following conditions, and calculate the ratios, Q_T and Q_S , of the peak area of haloperidol to that of the internal standard.

$$\begin{aligned} &\text{Amount (mg) of haloperidol (C}_{21}\text{H}_{23}\text{ClFNO}_2\text{)} \\ &= M_S \times Q_T/Q_S \times 2/5 \end{aligned}$$

M_S : Amount (mg) of haloperidol for assay taken

Internal standard solution—A solution of diphenyl in methanol (1 in 2000).

Operating conditions—

Detector: An ultraviolet absorption photometer (wavelength: 220 nm).

Column: A stainless steel column 4.6 mm in inside diameter and 15 cm in length, packed with octadecylsilanized silica gel for liquid chromatography (5 μ m in particle diameter).

Column temperature: A constant temperature of about 40°C.

Mobile phase: Dissolve 2.95 g of trisodium citrate dihydrate in 900 mL of water, adjust to pH 3.5 with dilute hydrochloric acid, and add water to make 1000 mL. To 250 mL of this solution add 750 mL of methanol and 1.0 g of sodium lauryl sulfate, and mix to dissolve.

Flow rate: Adjust so that the retention time of haloperidol is about 9 minutes.

System suitability—

System performance: When the procedure is run with 10 μ L of the standard solution under the above operating conditions, haloperidol and diphenyl are eluted in this order with the resolution between these peaks being not less than 5.

System repeatability: When the test is repeated 6 times with 10 μ L of the standard solution under the above operating conditions, the relative standard deviation of the ratio of the peak area of haloperidol to that of the internal standard is not more than 1.0%.

Containers and storage Containers—Tight containers.

Storage—Light-resistant for the tablets without coating.

Halothane

ハロタン



and enantiomer

$C_2HBrClF_3$; 197.38

(*2R,3R*)-2-Bromo-2-chloro-1,1,1-trifluoroethane
[151-67-7]

Halothane contains not less than 0.008% and not more than 0.012% of Thymol as a stabilizer.

Description Halothane is a clear, colorless, and mobile liquid.

It is miscible with ethanol (95), with diethyl ether and with isooctane.

It is slightly soluble in water.

It is a volatile, nonflammable liquid, and setting fire to its heated vapor does not support combustion.

It is affected by light.

Refractive index n_D^{20} : 1.369 – 1.371

Identification Transfer about 3 μ L of Halothane to a gas cell having light path 10 cm in length, and determine the infrared absorption spectrum as directed in the gas sampling method under Infrared Spectrophotometry <2.25>, and compare the spectrum with the Reference Spectrum: both spectra exhibit similar intensities of absorption at the same wave numbers.

Specific gravity <2.56> d_{20}^{20} : 1.872 – 1.877

Purity (1) Acidity or alkalinity—Shake 60 mL of Halothane with 60 mL of freshly boiled and cooled water vigorously for 3 minutes. Separate the water layer, and use this as the sample solution. To 20 mL of the sample solution add 1 drop of bromocresol purple TS and 0.10 mL of 0.01 mol/L sodium hydroxide VS: a red-purple color develops. To 20 mL of the sample solution add 1 drop of bromocresol purple TS and 0.6 mL of 0.01 mol/L hydrochloric acid VS: a yellow color is produced.

(2) Halide and halogen—To 5 mL of the sample solution obtained in (1) add 1 drop of nitric acid and 0.20 mL of silver nitrate TS: no turbidity is produced. To 10 mL of the sample solution obtained in (1) add 1 mL of potassium

iodide TS and 2 drops of starch TS, and allow to stand for 5 minutes: no blue color develops.

(3) Phosgene—Transfer 50 mL of Halothane to a dried 300-mL conical flask, suspend a strip of phosgene test paper vertically inside the flask with the lower end about 10 mm above the surface of the liquid, insert the stopper, and allow to stand at a dark place for 20 to 24 hours: the test paper shows no yellow color.

(4) Residue on evaporation—Pipet 50 mL of Halothane, evaporate on a water bath, and dry the residue at 105°C for 2 hours: the mass of the residue is not more than 1.0 mg.

(5) Volatile related substances—To 100 mL of Halothane add exactly 5.0 μ L of the internal standard, and use this solution as the sample solution. Perform the test with 5 μ L of the sample solution as directed under Gas Chromatography <2.02>, and determine each peak area by the automatic integration method: the total area of the peaks other than halothane and the internal standard is not larger than the peak area of the internal standard.

Internal standard—1,1,2-Trichloro-1,2,2-trifluoroethane
Operating conditions—

Detector: A hydrogen flame-ionization detector.

Column: A column about 3 mm in inside diameter and 3 m in length, at the first 2 m from the injection port, having macrogol 400 coated in the ratio of 30% on siliceous earth for gas chromatography (180 to 250 μ m in particle diameter), and at the remaining 1 m, having dinonyl phthalate coated in the ratio of 30% on siliceous earth for gas chromatography (180 to 250 μ m in particle diameter).

Column temperature: A constant temperature of about 50°C.

Carrier gas: Nitrogen.

Flow rate: Adjust so that the retention time of the internal standard is 2 to 3 minutes.

Selection of column: Mix 3 mL of Halothane and 1 mL of the internal standard. Proceed with 1 μ L of this solution under the above operating conditions, and calculate the resolution. Use a column giving elution of the internal standard and halothane in this order with the resolution between these peaks being not less than 10.

Detection sensitivity: Adjust the detection sensitivity so that the peak height of the internal standard obtained with 5 μ L of the sample solution composes 30 to 70% of the full scale.

Time span of measurement: About 3 times as long as the retention time of halothane.

Distilling range <2.57> Not less than 95 vol% distills within a 1°C range between 49°C and 51°C.

Thymol To 0.50 mL of Halothane add 5.0 mL of isooctane and 5.0 mL of titanium (IV) oxide TS, shake vigorously for 30 seconds, and allow to stand: the separated upper layer has more color than the following control solution A, and has no more color than the following control solution B.

Control solution: Dissolve 0.225 g of thymol for assay in isooctane to make exactly 100 mL. To 10 mL each of this solution, accurately measured, add isooctane to make exactly 150 mL and 100 mL, respectively. Proceed with 0.50 mL each of these solutions in the same manner as Halothane, and use the separated upper layers so obtained as the control solution A and B, respectively.

Containers and storage Containers—Tight containers.

Storage—Light-resistant, and not exceeding 30°C.

Haloxazolam

ハロキサゾラム

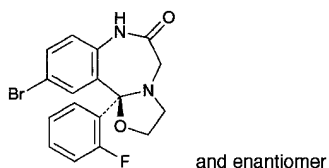

$C_{17}H_{14}BrFN_2O_2$: 377.21
 (11b*RS*)-10-Bromo-11b-(2-fluorophenyl)-2,3,7,11b-tetrahydro[1,3]oxazolo[3,2-*d*][1,4]benzodiazepin-6(5*H*)-one
 [59128-97-1]

Haloxazolam, when dried, contains not less than 99.0% of haloxazolam ($C_{17}H_{14}BrFN_2O_2$).

Description Haloxazolam occurs as white, crystals or crystalline powder. It is odorless and tasteless.

It is freely soluble in acetic acid (100), sparingly soluble in acetonitrile, in methanol and in ethanol (99.5), slightly soluble in diethyl ether, and practically insoluble in water.

Melting point: about 183°C (with decomposition).

Identification (1) Dissolve 10 mg of Haloxazolam in 10 mL of methanol, add 1 drop of hydrochloric acid: the solution shows a yellow-green fluorescence under ultraviolet light (main wavelength: 365 nm). To this solution add 1 mL of sodium hydroxide TS: the fluorescence disappears immediately.

(2) Prepare the test solution with 50 mg of Haloxazolam as directed under Oxygen Flask Combustion Method <1.06>, using a mixture of 20 mL of dilute sodium hydroxide TS and 1 mL of hydrogen peroxide (30) as an absorbing liquid: the test solution responds to Qualitative Tests <1.09> for bromide and for fluoride.

(3) Determine the absorption spectrum of a solution of Haloxazolam in methanol (1 in 100,000) as directed under Ultraviolet-visible Spectrophotometry <2.24>, and compare the spectrum with the Reference Spectrum: both spectra exhibit similar intensities of absorption at the same wavelengths.

(4) Determine the infrared absorption spectrum of Haloxazolam, previously dried, as directed in the potassium bromide disk method under Infrared Spectrophotometry <2.25>, and compare the spectrum with the Reference Spectrum: both spectra exhibit similar intensities of absorption at the same wave numbers.

Absorbance <2.24> $E_{1\text{cm}}^{1\%}$ (247 nm): 390 – 410 (10 mg, methanol, 1000 mL).

Purity (1) Clarity and color of solution—Dissolve 0.10 g of Haloxazolam in 20 mL of ethanol (99.5): the solution is clear and colorless.

(2) Soluble halides—To 1.0 g of Haloxazolam add 50 mL of water, allow to stand for 1 hour with occasional shaking, and filter. To 25 mL of the filtrate add 6 mL of dilute nitric acid and water to make 50 mL. Perform the test with this solution as directed under Chloride Limit Test <1.03>. Prepare the control solution with 0.10 mL of 0.01 mol/L hydrochloric acid VS.

(3) Heavy metals <1.07>—Proceed with 1.0 g of Haloxazolam according to Method 2, and perform the test. Prepare the control solution with 2.0 mL of Standard Lead Solution (not more than 20 ppm).

(4) Arsenic <1.11>—To 1.0 g of Haloxazolam in a decomposition flask add 5 mL of nitric acid and 2 mL of sulfuric acid, place a small funnel on the mouth of the flask, and heat carefully until white fumes are evolved. After cooling, add 2 mL of nitric acid, heat, repeat this procedure twice, add several 2-mL portions of hydrogen peroxide (30), and heat until the solution is colorless to pale yellow. After cooling, add 2 mL of a saturated solution of ammonium oxalate monohydrate, and heat until white fumes are evolved. After cooling, add water to make 5 mL, and perform the test with this solution: the solution has no more color than the following control solution (not more than 2 ppm).

Control solution: Proceed in the same manner as above without using Haloxazolam, add 2.0 mL of Standard Arsenic Solution and water to make 5 mL, and proceed in the same manner as the test solution.

(5) Related substances—Dissolve 0.10 g of Haloxazolam in 100 mL of acetonitrile, and use this solution as the sample solution. Pipet 1 mL of the sample solution, add acetonitrile to make exactly 100 mL, and use this solution as the standard solution. Perform the test with exactly 10 μ L each of the sample solution and standard solution as directed under Liquid Chromatography <2.01> according to the following conditions. Determine each peak area of both solutions by the automatic integration method: the total area of all peaks other than haloxazolam from the sample solution is not larger than the peak area of the haloxazolam from the standard solution.

Operating conditions—

Detector: An ultraviolet absorption photometer (wavelength: 250 nm).

Column: A stainless steel column 4.6 mm in inside diameter and 15 cm in length, packed with octadecylsilanized silica gel for liquid chromatography (5 μ m in particle diameter).

Column temperature: A constant temperature of about 25°C.

Mobile phase: Dissolve 6.2 g of boric acid and 7.5 g of potassium chloride in 900 mL of water, adjust the pH with triethylamine to 8.5, and add water to make 1000 mL. To 300 mL of this solution add 200 mL of acetonitrile.

Flow rate: Adjust so that the retention time of haloxazolam is about 10 minutes.

Time span of measurement: About 3 times as long as the retention time of haloxazolam, beginning after the solvent peak.

System suitability—

Test for required detectability: To exactly 5 mL of the standard solution add acetonitrile to make exactly 50 mL. Confirm that the peak area of haloxazolam obtained with 10 μ L of this solution is equivalent to 8 to 12% of that with 10 μ L of the standard solution.

System performance: Dissolve 10 mg each of Haloxazolam and cloxazolam in 200 mL of acetonitrile. When the procedure is run with 10 μ L of this solution under the above operating conditions, haloxazolam and cloxazolam are eluted in this order with the resolution between these peaks being not less than 1.5.

System repeatability: When the test is repeated 6 times with 10 μ L of the standard solution under the above operating conditions, the relative standard deviation of the peak area of haloxazolam is not more than 1.0%.

Loss on drying <2.41> Not more than 0.5% (1 g, 105°C, 3 hours).

Residue on ignition <2.44> Not more than 0.1% (1 g, platinum crucible).

Assay Weigh accurately about 0.5 g of Haloxazolam, previously dried, dissolve in 50 mL of acetic acid (100), and titrate <2.50> with 0.1 mol/L perchloric acid VS (potentiometric titration). Perform a blank determination in the same manner, and make any necessary correction.

Each mL of 0.1 mol/L perchloric acid VS
= 37.72 mg of $C_{17}H_{14}BrFN_2O_2$

Containers and storage Containers—Tight containers.
Storage—Light-resistant.

Heparin Calcium

へパリンカルシウム

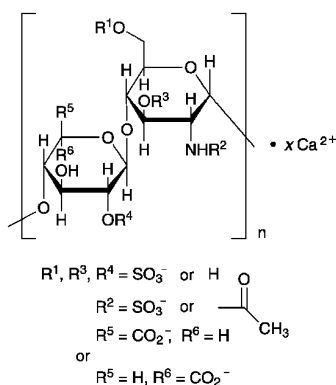

[37270-89-6]

Heparin Calcium is the calcium salt of sulfated glycosaminoglycans composed of disaccharide units of D-glucosamine and uronic acid (L-iduronic acid or D-glucuronic acid) obtained from the intestinal mucosa of healthy edible swine.

It contains not less than 180 Heparin Units (anti-factor IIa activity) per mg and not less than 8.0% and not more than 12.0% of calcium (Ca: 40.08), calculated on the dried basis.

Description Heparin Calcium occurs as a white to grayish brown, powder or grains.

It is freely soluble in water, and practically insoluble in ethanol (99.5).

It is hygroscopic.

Identification (1) Dissolve 10 mg of Heparin Calcium in 5 mL of water, and add 0.1 mL of 1 mol/L hydrochloric acid TS and 5 mL of toluidine blue O solution (1 in 20,000): a purple to red-purple color develops.

(2) Dissolve 1 mg each of Heparin Calcium and Heparin Sodium for Identification RS in 1 mL of water, and use these solutions as the sample solution and the standard solution, respectively. Perform the test with 20 μ L each of the sample solution and standard solution as directed under Liquid Chromatography <2.01> according to the following conditions: the retention time for the major peak from the sample solution and standard solution is identical.

Operating conditions—

Detector, column, column temperature, mobile phases A and B, flowing of mobile phase and flow rate: Proceed as directed under the operating conditions in Purity (9).

System suitability—

System performance: Dissolve 1.0 mg of Heparin Sodium for Identification RS in 0.60 mL of water. Dissolve 0.10 mg of Over-sulfated Chondroitin Sulfate for System Suitability

RS in 0.20 mL of water. Dissolve 1.0 mg of dermatan sulfate in 2.0 mL of water. To 90 μ L of the solution of Heparin Sodium for Identification RS add 30 μ L each of the solutions of Over-sulfated Chondroitin Sulfate for System Suitability RS and dermatan sulfate, and mix. When the procedure is run with 20 μ L of the mixture under the above operating conditions, dermatan sulfate, heparin and over-sulfated chondroitin sulfate are eluted in this order with the resolution between the peaks of dermatan sulfate and heparin being not less than 1.0 and that between the peaks of heparin and over-sulfated chondroitin sulfate being not less than 1.5.

(3) A solution of 50 mg of Heparin Calcium in 5 mL of water responds to Qualitative Tests <1.09> for calcium salt.

pH <2.54> Dissolve 1.0 g of Heparin Calcium in 100 mL of water: the pH of the solution is between 6.0 and 8.0.

Purity (1) Clarity and color of solution—Dissolve 0.5 g of Heparin Calcium in 20 mL of water: the solution is clear. Determine the absorbance of this solution at 400 nm as directed under Ultraviolet-visible Spectrophotometry <2.24>: the absorbance is not more than 0.05.

(2) Chloride <1.03>—Perform the test with 0.5 g of Heparin Calcium. Prepare the control solution with 0.30 mL of 0.01 mol/L hydrochloric acid VS (not more than 0.021%).

(3) Heavy metals <1.07>—Proceed with 0.5 g of Heparin Calcium according to Method 2, and perform the test. Prepare the control solution with 1.5 mL of Standard Lead Solution (not more than 30 ppm).

(4) Barium—Dissolve 30 mg of Heparin Calcium in 3.0 mL of water, and use this solution as the sample solution. To 1.0 mL of the sample solution add 3 drops of dilute sulfuric acid, and allow to stand for 10 minutes: no turbidity is produced.

(5) Total nitrogen—Weigh accurately about 0.1 g of Heparin Calcium, previously dried, and perform the test as directed under Nitrogen Determination <1.08>: the amount of nitrogen (N: 14.01) is not more than 3.0%.

(6) Protein—(i) Sodium carbonate solution: To 4 volumes of a mixture of sodium hydroxide solution (1 in 100) and anhydrous sodium carbonate solution (1 in 20) (1:1) add 1 volume of water.

(ii) Copper sulfate solution: To 4 volumes of a mixture of copper (II) sulfate pentahydrate solution (1 in 80) and sodium tartrate dihydrate solution (149 in 5000) (1:1) add 1 volume of water.

(iii) Alkaline copper solution for heparin: Mix 50 volumes of the sodium carbonate solution and 1 volume of the copper sulfate solution. Prepare before using.

(iv) Procedure: Use a solution of Heparin Calcium (1 in 200) as the sample solution. Use a solution of bovine serum albumin (1 in 40,000) as the standard solution. To exactly 1 mL each of the sample solution and standard solution add exactly 5 mL of the alkaline copper solution for heparin, mix, and allow them to stand at room temperature for 10 minutes. To each of these solutions add exactly 0.5 mL of diluted Folin's TS (1 in 2), shake, allow them to stand at room temperature for 30 minutes, and centrifuge at room temperature. Determine the absorbances at 750 nm of the supernatant liquids as directed under Ultraviolet-visible Spectrophotometry <2.24> using water as the blank: the absorbance of the solution obtained from the sample solution is not more than that of the solution from the standard solution.

(7) Nucleic acid—Dissolve 40 mg of Heparin Calcium in 10 mL of a solution of disodium dihydrogen ethylenediamine tetraacetate dihydrate (93 in 50,000), and determine

the absorbance of this solution at 260 nm as directed under Ultraviolet-visible Spectrophotometry <2.24>: the absorbance is not more than 0.15.

(8) Over-sulfated chondroitin sulfate—Dissolve 20 mg of Heparin Calcium in 0.60 mL of a solution of sodium 3-trimethylsilylpropionate- d_4 for nuclear magnetic resonance spectroscopy in heavy water for nuclear magnetic resonance spectroscopy (1 in 10,000). Determine the spectrum of this solution as directed under Nuclear Magnetic Resonance Spectroscopy <2.21> (^1H) in accordance with the following conditions, using sodium 3-trimethylsilylpropionate- d_4 for nuclear magnetic resonance spectroscopy as an internal reference compound: it exhibits no signal corresponding to *N*-acetyl proton of over-sulfated chondroitin sulfate at δ 2.18 \pm 0.05 ppm, or the signal disappears when determining the spectrum of the sample solutions as directed under ^1H with ^{13}C -decoupling.

Operating conditions—

Spectrometer: 1.1. FT-NMR, Not less than 400 MHz.

Temperature: 25°C.

Spinning: off.

Number of data points: 32,768.

Spectral range: Signal of DHO \pm 6.0 ppm.

Flip angle: 90°.

Delay time: 20 seconds.

Dummy scans: 4.

Number of scans: SN ratio of the signal of *N*-acetyl proton of heparin is not less than 1000.

Window function: Exponential function (Line broadening factor = 0.2 Hz).

System suitability—

System performance: Dissolve 20 mg of Heparin Calcium in 0.40 mL of a solution of sodium 3-trimethylsilylpropionate- d_4 for nuclear magnetic resonance spectroscopy in heavy water for nuclear magnetic resonance spectroscopy (1 in 10,000). Dissolve 0.10 mg of Over-sulfated Chondroitin Sulfate for System Suitability RS in 1.0 mL of a solution of sodium 3-trimethylsilylpropionate- d_4 for nuclear magnetic resonance spectroscopy in heavy water for nuclear magnetic resonance spectroscopy (1 in 10,000). To the solution of heparin calcium add 0.20 mL of the solution of Over-sulfated Chondroitin Sulfate for System Suitability RS. When determining the spectrum of this solution under the above operating conditions, it exhibits the signal of *N*-acetyl proton of heparin and the signal of *N*-acetyl proton of over-sulfated chondroitin sulfate at δ 2.04 \pm 0.02 ppm and δ 2.18 \pm 0.05 ppm, respectively.

(9) Related substances—Dissolve 2.0 mg of Heparin Calcium in 0.1 mL of water, and perform the test with exactly 20 μL of this solution as directed under Liquid Chromatography <2.01> according to the following conditions: it exhibits no peaks after the heparin peak.

Operating conditions—

Detector: An ultraviolet absorption photometer (wavelength: 202 nm).

Column: A stainless steel column 2.0 mm in inside diameter and 7.5 cm in length, packed with synthetic polymer for liquid chromatography to which diethylaminoethyl group binds (10 μm in particle diameter).

Column temperature: A constant temperature of about 35°C.

Mobile phase A: Dissolve 0.4 g of sodium dihydrogen phosphate dihydrate in 1000 mL of water, and adjust to pH 3.0 with diluted phosphoric acid (1 in 10).

Mobile phase B: Dissolve 0.4 g of sodium dihydrogen phosphate dihydrate and 106.4 g of lithium perchlorate in 1000 mL of water, and adjust to pH 3.0 with diluted phos-

phoric acid (1 in 10).

Flowing of mobile phase: Control the gradient by mixing the mobile phases A and B as directed in the following table.

Time after injection of sample (min)	Mobile phase A (vol%)	Mobile phase B (vol%)
0 – 3	90	10
3 – 15	90 \rightarrow 0	10 \rightarrow 100

Flow rate: 0.2 mL per minute.

Time span of measurement: About 2 times as long as the retention time of heparin, beginning after the solvent peak.

System suitability—

Test for required detectability: Dissolve 10 mg of Heparin Sodium for Identification RS in 0.40 mL of water, and use this solution as the heparin sodium standard stock solution. Separately, dissolve 0.10 mg of Over-sulfated Chondroitin Sulfate for System Suitability RS in 0.20 mL of water, and use this solution as the over-sulfated chondroitin sulfate standard solution. To 60 μL of the heparin sodium standard stock solution add 3 μL of the over-sulfated chondroitin sulfate standard solution and 12 μL of water, and mix. When the procedure is run with 20 μL of the mixture under the above operating conditions, it exhibits an over-sulfated chondroitin sulfate peak.

System performance: To 120 μL of the heparin sodium standard stock solution add 30 μL of the over-sulfated chondroitin sulfate standard solution, mix and use this solution as the solution for system suitability test. When the procedure is run with 20 μL of the solution for system suitability test under the above operating conditions, heparin and over-sulfated chondroitin sulfate are eluted in this order with the resolution between these peaks being not less than 1.5.

System repeatability: When the test is repeated 6 times with 20 μL of the solution for system suitability test under the above operating conditions, the relative standard deviation of the peak area of over-sulfated chondroitin sulfate is not more than 2.0%.

Loss on drying <2.41> Not more than 8% (50 mg, in vacuum, 60°C, 3 hours).

Bacterial endotoxins <4.01> Less than 0.0030 EU/heparin Unit.

Anti-factor Xa activity to anti-factor IIa activity ratio The ratio of the anti-factor Xa activity determined by the following method to the anti-factor IIa activity obtained in the Assay, calculated by dividing the former with the later, is 0.9 – 1.1.

Anti-factor Xa activity determination

(i) Substrate solution: Dissolve 25 mg of *N*-benzoyl-L-isoleucyl-L-glutamyl(γ -OR)-glycyl-L-arginyl-*p*-nitroanilide hydrochloride in 33.3 mL of water.

(ii) Anti-thrombin solution: Dissolve human anti-thrombin in water so that each mL contains 1 IU. To 150 μL of this solution add 2250 μL of buffer solution.

(iii) Factor Xa solution: To 1200 μL of factor Xa TS add 1200 μL of buffer solution.

(iv) Buffer solution: Proceed as directed in the Assay (1).

(v) Stopping solution: Proceed as directed in the Assay (1).

(vi) Heparin standard solutions: Proceed as directed in the Assay (1). However, the standard solutions are prepared based on anti-factor Xa activity Unit instead of Heparin Unit.

(vii) Heparin sample solutions: Proceed as directed in

the Assay (1). However, the sample solutions are prepared based on anti-factor Xa activity Unit instead of Heparin Unit.

(viii) Procedure: Transfer separately two 50- μ L portions of each different dilution of the heparin standard solutions and the heparin sample solutions and five 50- μ L portions of buffer solution as the blank to 1.5-mL tubes. Warm these 21 tubes, anti-thrombin solution, factor Xa solution and substrate solution at 37°C all together. Start the following procedure at 2 minutes after warming in the order: buffer solution, S₁, S₂, S₃, S₄, buffer solution, T₁, T₂, T₃, T₄, buffer solution, T₁, T₂, T₃, T₄, buffer solution, S₁, S₂, S₃, S₄, and buffer solution. To each tube add 50 μ L of anti-thrombin solution, mix, and warm at 37°C for exactly 4 minutes, add 100 μ L of factor Xa solution, mix, and incubate for exactly 12 minutes. Then, add 100 μ L of substrate solution, mix, incubate for exactly 4 minutes, add 50 μ L of stopping solution to each tube, and mix immediately. Separately, to 50 μ L of stopping solution add 100 μ L of substrate solution, 100 μ L of factor Xa solution, 50 μ L of anti-thrombin solution and 50 μ L of buffer solution, mix, and use this solution as a control. Determine the absorbance of each solution at 405 nm against the control. Confirm that the relative standard deviation of the reading of the blank is not more than 10%.

(ix) Calculations: When the regression expression, $y = I_c + A_{X_s} + B_{X_t}$, is obtained using y as log of the absorbance values, X_s as the concentration of the heparin standard solutions and X_t as the concentration of the heparin sample solutions, the potency ratio R is B/A .

I_c : Common intercept

A : Slope of regression expression of the heparin standard solution

B : Slope of regression expression of the heparin sample solution

Calculate anti-factor Xa activity per mg of Heparin Calcium by the following formula.

$$\text{Anti-factor Xa activity per mg of Heparin Calcium} = 100 \times R \times V/M$$

V : Total volume (mL) of the solution (the sample stock solution) prepared as containing about 100 anti-factor Xa activity Units per mL

M : Amount (mg) of Heparin Calcium taken for the sample stock solution

However, when a 90% confidence interval of D of the regression expression $y = I_c + A'_{X_s} + B'_{X_t} + D$, where D is a constant term showing the difference between the blank and the intercept assumed from the two lines, is not in the range of between -0.2 and 0.2 , analyze by excluding the measurements of the blank.

The criteria for the test suitability are performed as directed in the Assay (1). When these criteria are not satisfied, repeat the test after changing the dilution rate so that the potency ratio becomes about 1 using the obtained potency as reference.

Assay (1) Heparin

(i) Substrate solution: Dissolve 25 mg of *H*-D-phenylalanyl-L-pipecolyl-L-arginyl-*p*-nitroanilide dihydrochloride in 32.0 mL of water.

(ii) Anti-thrombin solution (for heparin assay): Dissolve human anti-thrombin in water so that each mL contains 1 IU. Dilute this solution to an appropriate dilution factor of approximately more than 16 times with the buffer solution, and designate this solution as the anti-thrombin solution (for heparin assay). The dilution factor with the buffer solution

is adjusted so that the absorbance of reaction solution with the blank solution (average of five tubes) is not more than 2.0, and that of reaction solution with S₄ (0.020 Unit/mL heparin standard solution) (average of two tubes) is not less than 0.2 and not more than 1.0 when the test is performed according to the Assay. The absorbance is measured with 1 cm light path in length.

(iii) Factor IIa solution: Add an equivalent volume of water to the buffer solution, and use this solution as the factor IIa diluent. Dissolve factor IIa in the factor IIa diluent to make a solution so that each mL contains 20 IU. Dilute this solution to an appropriate dilution factor of approximately less than 4 times with the factor IIa diluent, and designate this solution as the factor IIa solution. Adjust the dilution factor with the factor IIa diluent so that the absorbance of reaction solution with the blank solution (average of five tubes) is not more than 2.0, and that of reaction solution with S₄ (0.020 Unit/mL heparin standard solution) (average of two tubes) is not less than 0.2 and not more than 1.0 when the test is performed according to the Assay. The absorbance is measured with 1 cm light path in length.

(iv) Buffer solution: Dissolve 6.1 g of 2-amino-2-hydroxymethyl-1,3-propanediol, 10.2 g of sodium chloride, 2.8 g of disodium dihydrogen ethylenediamine tetraacetate dihydrate and 1.0 g of polyethylene glycol 6000 in 800 mL of water, adjust to pH 8.4 with 1 mol/L hydrochloric acid TS, and add water to make 1000 mL.

(v) Stopping solution: To 2 mL of acetic acid (100) add water to make 10 mL.

(vi) Heparin standard solutions: Dissolve Heparin Sodium RS in water so that each mL contains 100 Heparin Units, and use this solution as the standard stock solution. Dilute the standard stock solution with buffer solution so that each mL contains exactly 0.1 Heparin Units, and use this solution as the standard solution. Make heparin standard solutions S₁, S₂, S₃ and S₄ respectively by adding the standard solution to buffer solution as directed in the following table.

Heparin standard solution		Buffer solution (μ L)	Standard solution (μ L)
No.	Heparin concentration (Unit/mL)		
S ₁	0.005	950	50
S ₂	0.010	900	100
S ₃	0.015	850	150
S ₄	0.020	800	200

(vii) Heparin sample solutions: Weigh accurately an appropriate amount of Heparin Calcium, dissolve in water so that each mL contains about 100 Heparin Units, and use this solution as the sample stock solution. Dilute exactly the sample stock solution with buffer solution so that each mL contains 0.1 Heparin Units, and use this solution as the sample solution. Make heparin sample solutions T₁, T₂, T₃ and T₄ respectively by adding the sample solution to buffer solution as directed in the following table.

Heparin sample solution		Buffer solution (μL)	Sample solution (μL)
No.	Heparin concentration (Unit/mL)		
T ₁	0.005	950	50
T ₂	0.010	900	100
T ₃	0.015	850	150
T ₄	0.020	800	200

(viii) Procedure: Transfer separately two 50- μL portions of each dilution of the heparin standard solutions and the heparin sample solutions and five 50- μL portions of buffer solution as the blank to 1.5-mL tubes. Warm these 21 tubes, anti-thrombin solution (for heparin assay), factor IIa solution and substrate solution at 37°C all together. Start the following procedure at 2 minutes after warming in the order: buffer solution, S₁, S₂, S₃, S₄, buffer solution, T₁, T₂, T₃, T₄, buffer solution, T₁, T₂, T₃, T₄, buffer solution, S₁, S₂, S₃, S₄, and buffer solution. To each tube add 100 μL of anti-thrombin solution (for heparin assay), mix, and warm at 37°C for exactly 4 minutes, add 25 μL of factor IIa solution, mix, and incubate for exactly 4 minutes. Then, add 50 μL of substrate solution, mix, incubate for exactly 4 minutes, add 50 μL of stopping solution to each tube, and mix. Separately, to 50 μL of stopping solution add 50 μL of substrate solution, 25 μL of factor IIa solution, 100 μL of anti-thrombin solution (for heparin assay) and 50 μL of buffer solution, mix, and use this solution as a control. Determine the absorbance of each solution at 405 nm against the control. Confirm that the relative standard deviation of the reading of the blank is not more than 10%.

(ix) Calculations: When the regression expression, $y = I_c + A_{X_s} + B_{X_t}$, is obtained using y as log of the absorbance values, X_s as the concentration of the heparin standard solutions and X_t as the concentration of the heparin sample solutions, the potency ratio R is B/A .

I_c : Common intercept

A : Slope of regression expression of the heparin standard solution

B : Slope of regression expression of the heparin sample solution

Calculate Heparin Unit (anti-factor IIa activity) per mg of Heparin Calcium by the following formula.

Heparin Unit (anti-factor IIa activity) per mg of Heparin Calcium

$$= 100 \times R \times V/M$$

V : Total volume (mL) of the solution (the sample stock solution) prepared as containing about 100 Heparin Units (anti-factor IIa activity) per mL

M : Amount (mg) of Heparin Calcium taken for the sample stock solution

However, when a 90% confidence interval of D of the regression expression $y = I'_c + A'_{X_s} + B'_{X_t} + D$, where D is a constant term showing the difference between the blank and the intercept assumed from the two lines, is not in the range of between -0.2 and 0.2 , analyze by excluding the measurements of the blank.

The criteria for the test suitability are the following 3 items, (1), (2) and (3).

(1) Judgment on consistence of the intercept assumed

from the two lines

When the regression expression, $y = I_s + A''_{X_s} + B''_{X_t} + I_{t-s}$, is obtained from the data of the heparin standard solutions and the heparin sample solutions except of the blank solution, a 90% confidence interval of the constant term, I_{t-s} , is between -0.2 and 0.2 .

I_s : Intercept of the regression expression of the heparin standard solution

I_{t-s} : Difference of the intercepts assumed from the two lines

(2) Judgment on linearity

When the regression expression, $y = I_c + A'''_{X_s} + B'''_{X_t} + Q_{sX_s^2} + Q_{tX_t^2}$, is obtained from the data of the heparin standard solutions and the heparin sample solutions, a 90% confidence interval of the secondary coefficients, Q_s and Q_t , is between -1000 and 1000 .

Q_s : Secondary coefficient of the regression expression of the heparin standard solution

Q_t : Secondary coefficient of the regression expression of the heparin sample solution

(3) Judgment by checking if the relative potency obtained is within the range previously validated on this test method

The potency ratio obtained is not less than 0.8 and not more than 1.2.

When these criteria are not satisfied, repeat the test after changing the dilution rate so that the potency ratio becomes about 1 using the obtained potency as reference.

(2) Calcium: Weigh accurately about 50 mg of Heparin Calcium, dissolve in 20 mL of water, add 2 mL of 8 mol/L potassium hydroxide TS, allow to stand for 3 to 5 minutes with occasional shaking, add 0.1 g of NN indicator, and immediately titrate <2.50> with 0.01 mol/L disodium dihydrogen ethylenediamine tetraacetate VS until the color of the solution changes from red-purple to blue.

$$\begin{aligned} &\text{Each mL of 0.01 mol/L disodium dihydrogen} \\ &\text{ethylenediamine tetraacetate VS} \\ &= 0.4008 \text{ mg of Ca} \end{aligned}$$

Containers and storage Containers—Tight containers.

Heparin Sodium

ヘパリンナトリウム

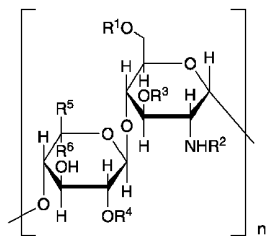

$R^1, R^3, R^4 = \text{SO}_3\text{Na}$ or H

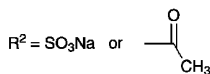

$R^5 = \text{CO}_2\text{Na}$, $R^6 = \text{H}$

or $R^5 = \text{H}$, $R^6 = \text{CO}_2\text{Na}$

[9041-08-1]

Heparin Sodium is a sodium salt of sulfated glycosaminoglycans composed of disaccharide units of D-glucosamine and uronic acid (L-iduronic acid or D-glucuronic acid) obtained from the intestinal mucosa of healthy edible swine.

It contains not less than 180 Heparin Units (anti-factor IIa activity) per mg, calculated on the dried basis.

Description Heparin Sodium occurs as a white to grayish brown, powder or grains. It is odorless.

It is soluble in water, and practically insoluble in ethanol (95) and in diethyl ether.

It is hygroscopic.

Identification Dissolve 1 mg each of Heparin Sodium and Heparin Sodium for Identification RS in 1 mL of water, and use these solutions as the sample solution and the standard solution, respectively. Perform the test with 20 μL each of the sample solution and standard solution as directed under Liquid Chromatography <2.01> according to the following conditions: the retention time for the major peak from the sample solution and standard solution is identical.

Operating conditions—

Detector, column, column temperature, mobile phases A and B, flowing of mobile phase and flow rate: Proceed as directed under the operating conditions in Purity (7).

System suitability—

System performance: Dissolve 1.0 mg of Heparin Sodium for Identification RS in 0.60 mL of water. Dissolve 0.10 mg of Over-sulfated Chondroitin Sulfate for System Suitability RS in 0.20 mL of water. Dissolve 1.0 mg of dermatan sulfate in 2.0 mL of water. To 90 μL of the solution of Heparin Sodium for Identification RS add 30 μL each of the solutions of Over-sulfated Chondroitin Sulfate for System Suitability RS and dermatan sulfate, and mix. When the procedure is run with 20 μL of the mixture under the above operating conditions, dermatan sulfate, heparin and over-sulfated chondroitin sulfate are eluted in this order with the resolution between the peaks of dermatan sulfate and heparin being not less than 1.0 and that between the peaks of heparin and over-sulfated chondroitin sulfate being not less than 1.5.

pH <2.54> The pH of a solution of 1.0 g of Heparin Sodium in 100 mL of water is between 6.0 and 8.0.

Purity (1) Clarity and color of solution—Dissolve 0.5 g of Heparin Sodium in 20 mL of water: the solution is clear and colorless to light yellow.

(2) Barium—Dissolve 30 mg of Heparin Sodium in 3.0 mL of water, and use this solution as the sample solution. To 1.0 mL of the sample solution add 3 drops of dilute sulfuric acid, and allow to stand for 10 minutes: no turbidity is produced.

(3) Total nitrogen—Weigh accurately about 0.1 g of Heparin Sodium, previously dried at 60°C for 3 hours under reduced pressure, and perform the test as directed under Nitrogen Determination <1.08>: the amount of nitrogen (N: 14.01) is not more than 3.0%.

(4) Protein—(i) Sodium carbonate solution: To 4 volumes of a mixture of sodium hydroxide solution (1 in 100) and anhydrous sodium carbonate solution (1 in 20) (1:1) add 1 volume of water.

(ii) Copper sulfate solution: To 4 volumes of a mixture of copper (II) sulfate pentahydrate solution (1 in 80) and sodium tartrate dihydrate solution (149 in 5000) (1:1) add 1 volume of water.

(iii) Alkaline copper solution for heparin: Mix 50 volumes of the sodium carbonate solution and 1 volume of the copper sulfate solution. Prepare before using.

(iv) Procedure: Use a solution of Heparin Sodium (1 in 200) as the sample solution. Use a solution of bovine serum albumin (1 in 40,000) as the standard solution. To exactly 1 mL each of the sample solution and standard solution add exactly 5 mL of the alkaline copper solution for heparin, mix, and allow them to stand at room temperature for 10 minutes. To each of these solutions add exactly 0.5 mL of diluted Folin's TS (1 in 2), shake, and allow them to stand at room temperature for 30 minutes. Determine the absorbances at 750 nm of these solutions as directed under Ultraviolet-visible Spectrophotometry <2.24> using water as the blank: the absorbance of the solution obtained from the sample solution is not more than that of the solution from the standard solution.

(5) Nucleic acid—Dissolve 40 mg of Heparin Sodium in 10 mL of water, and determine the absorbance of this solution at 260 nm as directed under Ultraviolet-visible Spectrophotometry <2.24>: the absorbance is not more than 0.15.

(6) Over-sulfated chondroitin sulfate—Dissolve 20 mg of Heparin Sodium in 0.60 mL of a solution of sodium 3-trimethylsilylpropionate- d_4 for nuclear magnetic resonance spectroscopy in heavy water for nuclear magnetic resonance spectroscopy (1 in 10,000). Determine the spectrum of this solution as directed under Nuclear Magnetic Resonance Spectroscopy <2.21> (^1H) in accordance with the following conditions, using sodium 3-trimethylsilylpropionate- d_4 for nuclear magnetic resonance spectroscopy as an internal reference compound: it exhibits no signal corresponding to *N*-acetyl proton of over-sulfated chondroitin sulfate at δ 2.15 \pm 0.02 ppm, or the signal disappears when determining the spectrum of the sample solutions as directed under ^1H with ^{13}C -decoupling.

Operating conditions—

Spectrometer: 1.1. FT-NMR, Not less than 400 MHz.

Temperature: 25°C.

Spinning: off.

Number of data points: 32,768.

Spectral range: Signal of DHO \pm 6.0 ppm.

Flip angle: 90°.

Delay time: 20 seconds.

Dummy scans: 4.

Number of scans: SN ratio of the signal of *N*-acetyl proton of heparin is not less 1000.

Window function: Exponential function (Line broadening factor = 0.2 Hz).

System suitability—

System performance: Dissolve 20 mg of Heparin Sodium for Identification RS in 0.40 mL of a solution of sodium 3-trimethylsilylpropionate- d_4 for nuclear magnetic resonance spectroscopy in heavy water for nuclear magnetic resonance spectroscopy (1 in 10,000). Dissolve 0.10 mg of Over-sulfated Chondroitin Sulfate for System Suitability RS in 1.0 mL of a solution of sodium 3-trimethylsilylpropionate- d_4 for nuclear magnetic resonance spectroscopy in heavy water for nuclear magnetic resonance spectroscopy (1 in 10,000). To the solution of Heparin Sodium for Identification RS add 0.20 mL of the solution of Over-sulfated Chondroitin Sulfate for System Suitability RS. When determining the spectrum of this solution under the above operating conditions, it exhibits the signal of *N*-acetyl proton of heparin and the signal of *N*-acetyl proton of over-sulfated chondroitin sulfate at δ 2.04 \pm 0.02 ppm and δ 2.15 \pm 0.02 ppm, respectively.

(7) Related substances—Dissolve 2.0 mg of Heparin Sodium in 0.1 mL of water and perform the test with exactly 20 μ L of this solution as directed under Liquid Chromatography <2.01> according to the following conditions: it exhibits no peaks after the heparin peak.

Operating conditions—

Detector: An ultraviolet absorption photometer (wavelength: 202 nm).

Column: A stainless steel column 2.0 mm in inside diameter and 7.5 cm in length, packed with synthetic polymer for liquid chromatography to which diethylaminoethyl group binds (10 μ m in particle diameter).

Column temperature: A constant temperature of about 35°C.

Mobile phase A: Dissolve 0.4 g of sodium dihydrogen phosphate dihydrate in 1000 mL of water, and adjust to pH 3.0 with diluted phosphoric acid (1 in 10).

Mobile phase B: Dissolve 0.4 g of sodium dihydrogen phosphate dihydrate and 106.4 g of lithium perchlorate in 1000 mL of water, and adjust to a pH of 3.0 with diluted phosphoric acid (1 in 10).

Flowing of mobile phase: Control the gradient by mixing the mobile phases A and B as directed in the following table.

Time after injection of sample (min)	Mobile phase A (vol%)	Mobile phase B (vol%)
0 – 3	90	10
3 – 15	90 \rightarrow 0	10 \rightarrow 100

Flow rate: 0.2 mL per minute.

Time span of measurement: About 2 times as long as the retention time of heparin, beginning after the solvent peak.

System suitability—

Test for required detectability: Dissolve 10 mg of Heparin Sodium for Identification RS in 0.40 mL of water, and use this solution as the heparin sodium standard stock solution. Separately, dissolve 0.10 mg of Over-sulfated Chondroitin Sulfate for System Suitability RS in 0.20 mL of water, and use this solution as the over-sulfated chondroitin sulfate standard solution. To 60 μ L of the heparin sodium standard stock solution add 3 μ L of the over-sulfated chondroitin sulfate standard solution and 12 μ L of water, and mix. When the procedure is run with 20 μ L of the mixture under the above operating conditions, it exhibits a peak for over-sulfated chondroitin sulfate.

System performance: To 120 μ L of the heparin sodium standard stock solution add 30 μ L of the over-sulfated chondroitin sulfate standard solution, mix and use this solution as the solution for system suitability test. When the procedure is run with 20 μ L of the solution for system suitability test under the above operating conditions, heparin and over-sulfated chondroitin sulfate are eluted in this order with the resolution between these peaks being not less than 1.5.

System repeatability: When the test is repeated 6 times with 20 μ L of the solution for system suitability test under the above operating conditions, the relative standard deviation of the peak area of over-sulfated chondroitin sulfate is not more than 2.0%.

(8) Galactosamine—Dissolve 2.4 mg of Heparin Sodium in 1.0 mL of a mixture of water and hydrochloric acid (7:5), and use this solution as the heparin sodium stock solution. Dissolve 8.0 mg of D-glucosamine hydrochloride in a mixture of water and hydrochloric acid (7:5) to make exactly 10 mL. Dissolve 8.0 mg of D-galactosamine hydrochloride in a mixture of water and hydrochloric acid (7:5) to make exactly 10 mL. To 99 volumes of the solution of D-glucosamine add 1 volume of the solution of D-galactosamine, and use this solution as the standard stock solution. Transfer 500 μ L each of the heparin sodium stock solution and the standard stock solution to a glass-stoppered test tube, stopper tightly, and heat at 100°C for 6 hours. After cooling to room temperature, evaporate 100 μ L each of the reaction solutions to dryness. Add 50 μ L of methanol to each of the residues and evaporate to dryness at room temperature. Dissolve each of the residues in 10 μ L of water, add 40 μ L of aminobenzoate derivatization TS, and heat at 80°C for 1 hour. After cooling to room temperature, evaporate the reaction solutions to dryness. Add 200 μ L of each of water and ethyl acetate to each of the residues, shake vigorously, and then centrifuge. After remove the upper layers, add 200 μ L of ethyl acetate to each of the lower layers, shake vigorously, and then centrifuge. These lower layers are used as the sample solution and the standard solution. Perform the test with 5 μ L each of the sample solution and standard solution as directed under Liquid Chromatography <2.01> according to the following conditions: the peak area ratio of galactosamine to glucosamine of the sample solution is not larger than that of the standard solution.

Operating conditions—

Detector: A fluorescence photometer (excitation wavelength: 305 nm; emission wavelength: 360 nm).

Column: A stainless steel column 4.6 mm in inside diameter and 15 cm in length, packed with octadecylsilanized silica gel for liquid chromatography (3 μ m in particle diameter).

Column temperature: A constant temperature of about 45°C.

Mobile phase: To 100 mL of a mixture of water and trifluoroacetic acid (1000:1) add 100 mL of acetonitrile. Add 140 mL of the solution to 860 mL of a mixture of water and trifluoroacetic acid (1000:1).

Flow rate: 1.0 mL per minute.

Time span of measurement: About 50 minutes after injected.

System suitability—

Test for required detectability: Dissolve 8.0 mg of D-mannosamine hydrochloride in 10 mL of a mixture of water and hydrochloric acid (7:5), and use this solution as the mannosamine standard solution. Transfer 500 μ L of a mixture of the standard stock solution and the mannosamine standard solution (100:1) to a glass-stoppered test tube, stopper tightly, and heat at 100°C for 6 hours. After cooling this solution to room temperature, evaporate 100 μ L of the reaction solu-

tion to dryness. Add 50 μL of methanol to the residue and evaporate to dryness at room temperature. Dissolve the residue in 10 μL of water, add 40 μL of aminobenzoate derivatization TS, and heat at 80°C for 1 hour. After cooling to room temperature, evaporate the reaction solution to dryness. Add 200 μL each of water and ethyl acetate to the residue, shake vigorously, and then centrifuge. After removing the upper layer, add 200 μL of ethyl acetate to the lower layer, shake vigorously, and then centrifuge. The lower layer is used as the solution for system suitability test. When the procedure is run with 5 μL of the solution for system suitability test under the above operating conditions, the ratio of the peak area of galactosamine to that of glucosamine is 0.7 – 2.0%.

System performance: When the procedure is run with 5 μL of the solution for system suitability test under the above operating conditions, glucosamine, mannosamine and galactosamine are eluted in this order with the resolutions between the peaks of glucosamine and mannosamine and between the peaks of mannosamine and galactosamine being not less than 1.5, respectively.

System repeatability: When the test is repeated 6 times with 5 μL of the solution for system suitability test under the above operating conditions, the relative standard deviation of the ratio of the peak area of galactosamine to that of glucosamine is not more than 4.0%.

Loss on drying <2.41> Not more than 10% (20 mg, in vacuum, 60°C, 3 hours).

Residue on ignition <2.44> Not more than 40% (after drying, 20 mg).

Bacterial endotoxins <4.01> Less than 0.0030 EU/Heparin Unit.

Anti-factor Xa activity to anti-factor IIa activity ratio The ratio of the anti-factor Xa activity determined by the following method to the anti-factor IIa activity obtained in the Assay, calculated by dividing the former with the later, is 0.9 – 1.1.

Anti-factor Xa activity determination

(i) **Substrate solution:** Dissolve 25 mg of *N*-benzoyl-L-iso-leucyl-L-glutamyl(γ -OR)-glycyl-L-arginyl-*p*-nitroanilide hydrochloride in 33.3 mL of water.

(ii) **Anti-thrombin solution:** Dissolve human anti-thrombin in water so that each mL contains 1 IU. To 150 μL of this solution add 2250 μL of buffer solution

(iii) **Factor Xa solution:** To 1200 μL of factor Xa TS add 1200 μL of buffer solution.

(iv) **Buffer solution:** Proceed as directed in the Assay.

(v) **Stopping solution:** Proceed as directed in the Assay.

(vi) **Heparin standard solutions:** Proceed as directed in the Assay. However, the standard solutions are prepared based on anti-factor Xa activity Unit instead of Heparin Unit.

(vii) **Heparin sample solutions:** Proceed as directed in the Assay. However, the sample solutions are prepared based on anti-factor Xa activity Unit instead of Heparin Unit.

(viii) **Procedure:** Transfer separately two 50- μL portions of each dilution of the heparin standard solutions and the heparin sample solutions and five 50- μL portions of buffer solution as the blank to 1.5 mL-tubes. Warm these 21 tubes, anti-thrombin solution, factor Xa solution and substrate solution at 37°C all together. Start the following procedure at 2 minutes after warming in the order: buffer solution, S₁, S₂, S₃, S₄, buffer solution, T₁, T₂, T₃, T₄, buffer solution, T₁, T₂, T₃, T₄, buffer solution, S₁, S₂, S₃, S₄, and buffer solu-

tion. To each tube add 50 μL of anti-thrombin solution, mix, and warm at 37°C for exactly 4 minutes, add 100 μL of factor Xa solution, mix, and incubate for exactly 12 minutes. Then, add 100 μL of substrate solution, mix, incubate for exactly 4 minutes, add 50 μL of stopping solution to each tube, and mix immediately. Separately, to 50 μL of stopping solution add 100 μL of substrate solution, 100 μL of factor Xa solution, 50 μL of anti-thrombin solution and 50 μL of buffer solution, mix, and use this solution as a control. Determine the absorbance of each solution at 405 nm against the control. Confirm that the relative standard deviation of the reading of the blank is not more than 10%.

(ix) **Calculations:** When the regression expression, $y = I_c + A_{X_s} + B_{X_t}$, is obtained using y as log of the absorbance values, X_s as the concentration of the heparin standard solutions and X_t as the concentration of the heparin sample solutions, the potency ratio R is B/A .

I_c : Common intercept

A : Slope of regression expression of the heparin standard solution

B : Slope of regression expression of the heparin sample solution

Calculate anti-factor Xa activity per mg of Heparin Sodium by the following formula.

$$\text{Anti-factor Xa activity per mg of Heparin Sodium} = 100 \times R \times V/M$$

V : Total volume (mL) of the solution (the sample stock solution) prepared as containing about 100 anti-factor Xa activity Units per mL

M : Amount (mg) of Heparin Sodium taken for the sample stock solution

However, when a 90% confidence interval of D of the regression expression $y = I'_c + A'_{X_s} + B'_{X_t} + D$, where D is a constant term showing the difference between the blank and the intercept assumed from the two lines, is not in a range of between -0.2 and 0.2, analyze by excluding the measurements of the blank.

The criteria for the test suitability are performed as directed in the Assay. When these criteria are not satisfied, repeat the test after changing the dilution rate so that the potency ratio becomes about 1 using the obtained potency as reference.

Assay

(i) **Substrate solution:** Dissolve 25 mg of *H*-D-phenylalanyl-L-pipecolyl-L-arginyl-*p*-nitroanilide dihydrochloride in 32.0 mL of water.

(ii) **Anti-thrombin solution (for heparin assay):** Dissolve human anti-thrombin in water so that each mL contains 1 IU. Dilute this solution to an appropriate dilution factor of approximately more than 16 times with the buffer solution, and designate this solution as the anti-thrombin solution (for heparin assay). The dilution factor with the buffer solution is adjusted so that the absorbance of reaction solution with the blank solution (average of five tubes) is not more than 2.0, and that of reaction solution with S₄ (0.020 Unit/mL heparin standard solution) (average of two tubes) is not less than 0.2 and not more than 1.0 when the test is performed according to the Assay. The absorbance is measured with 1 cm light path in length.

(iii) **Factor IIa solution:** Add an equivalent volume of water to the buffer solution, and use this solution as the factor IIa diluent. Dissolve factor IIa in the factor IIa diluent to make a solution so that each mL contains 20 IU. Dilute this solution to an appropriate dilution factor of approximately

less than 4 times with the factor Iia diluent, and designate this solution as the factor Iia solution. Adjust the dilution factor with the factor Iia diluent so that the absorbance of reaction solution with the blank solution (average of five tubes) is not more than 2.0, and that of reaction solution with S_4 (0.020 Unit/mL heparin standard solution) (average of two tubes) is not less than 0.2 and not more than 1.0 when the test is performed according to the Assay. The absorbance is measured with 1 cm light path in length.

(iv) Buffer solution: Dissolve 6.1 g of 2-amino-2-hydroxymethyl-1,3-propanediol, 10.2 g of sodium chloride, 2.8 g of disodium dihydrogen ethylenediamine tetraacetate dihydrate and 1.0 g of polyethylene glycol 6000 in 800 mL of water, adjust to pH 8.4 with 1 mol/L hydrochloric acid TS, and add water to make 1000 mL.

(v) Stopping solution: To 2 mL of acetic acid (100) add water to make 10 mL.

(vi) Heparin standard solutions: Dissolve Heparin Sodium RS in water so that each mL contains 100 Heparin Units, and use this solution as the standard stock solution. Dilute the standard stock solution with buffer solution so that each mL contains exactly 0.1 Heparin Units, and use this solution as the standard solution. Make heparin standard solutions S_1 , S_2 , S_3 and S_4 respectively by adding the standard solution to buffer solution as directed in the following table.

Heparin standard solution		Buffer solution (μL)	Standard solution (μL)
No.	Heparin concentration (Unit/mL)		
S_1	0.005	950	50
S_2	0.010	900	100
S_3	0.015	850	150
S_4	0.020	800	200

(vii) Heparin sample solutions: Weigh accurately an appropriate amount of Heparin Sodium, dissolve in water so that each mL contains about 100 Heparin Units, and use this solution as the sample stock solution. Dilute exactly the sample stock solution with buffer solution so that each mL contains 0.1 Heparin Units, and use this solution as the sample solution. Make heparin sample solutions T_1 , T_2 , T_3 and T_4 respectively by adding the sample solution to buffer solution as directed in the following table.

Heparin sample solution		Buffer solution (μL)	Sample solution (μL)
No.	Heparin concentration (Unit/mL)		
T_1	0.005	950	50
T_2	0.010	900	100
T_3	0.015	850	150
T_4	0.020	800	200

(viii) Procedure: Transfer separately two 50- μL portions of each dilution of the heparin standard solutions and the heparin sample solutions and five 50- μL portions of buffer solution as the blank to 1.5 mL-tubes. Warm these 21 tubes, anti-thrombin solution (for heparin assay), factor Iia solu-

tion and substrate solution at 37°C all together. Start the following procedure at 2 minutes after warming in the order: buffer solution, S_1 , S_2 , S_3 , S_4 , buffer solution, T_1 , T_2 , T_3 , T_4 , buffer solution, T_1 , T_2 , T_3 , T_4 , buffer solution, S_1 , S_2 , S_3 , S_4 , and buffer solution. To each tube add 100 μL of anti-thrombin solution (for heparin assay), mix, and warm at 37°C for exactly 4 minutes, add 25 μL of factor Iia solution, mix, and incubate for exactly 4 minutes. Then, add 50 μL of substrate solution, mix, incubate for exactly 4 minutes, add 50 μL of stopping solution to each tube, and mix. Separately, to 50 μL of stopping solution add 50 μL of substrate solution, 25 μL of factor Iia solution, 100 μL of anti-thrombin solution (for heparin assay) and 50 μL of buffer solution, mix, and use this solution as a control. Determine the absorbance of each solution at 405 nm against the control. Confirm that the relative standard deviation of the reading of the blank is not more than 10%.

(ix) Calculations: When the regression expression, $y = I_c + A_{X_s} + B_{X_t}$, is obtained using y as log of the absorbance values, X_s as the concentration of the heparin standard solutions and X_t as the concentration of the heparin sample solutions, the potency ratio R is B/A .

I_c : Common intercept

A : Slope of regression expression of the heparin standard solution

B : Slope of regression expression of the heparin sample solution

Calculate Heparin Unit (anti-factor Iia activity) per mg of Heparin Sodium by the following formula.

Heparin Unit (anti-factor Iia activity) per mg of Heparin Sodium

$$= 100 \times R \times V/M$$

V : Total volume (mL) of the solution (the sample stock solution) prepared as containing about 100 Heparin Units (anti-factor Iia activity) per mL

M : Amount (mg) of Heparin Sodium taken for the sample stock solution

However, when a 90% confidence interval of D of the regression expression $y = I'_c + A'_{X_s} + B'_{X_t} + D$, where D is a constant term showing the difference between the blank and the intercept assumed from the two lines, is not in the range of between -0.2 and 0.2 , analyze by excluding the measurements of the blank.

The criteria for the test suitability are the following 3 items, (1), (2) and (3).

(1) Judgment on consistence of the intercept assumed from the two lines

When the regression expression, $y = I_s + A''_{X_s} + B''_{X_t} + I_{t-s}$, is obtained from the data of the heparin standard solution and the heparin sample solution except of the blank solution, a 90% confidence interval of the constant term, I_{t-s} , is between -0.2 and 0.2 .

I_s : Intercept of the regression expression of the heparin standard solution

I_{t-s} : Difference of the intercepts assumed from the two lines

(2) Judgment on linearity

When the regression expression, $y = I_c + A''_{X_s} + B''_{X_t} + Q_{sX_s^2} + Q_{tX_t^2}$, is obtained from the data of the heparin standard solution and the heparin sample solution, a 90% confidence interval of the secondary coefficients, Q_s and Q_t , is between -1000 and 1000 .

Q_s : Secondary coefficient of the regression expression of the heparin standard solution

Q_t : Secondary coefficient of the regression expression of the heparin sample solution

(3) Judgment by checking if the relative potency obtained is within the range previously validated on this test method

The potency ratio obtained is not less than 0.8 and not more than 1.2.

When these criteria are not satisfied, repeat the test after changing the dilution rate so that the potency ratio becomes about 1 using the obtained potency as reference.

Containers and storage Containers—Tight containers.

Heparin Sodium Injection

ヘパリンナトリウム注射液

Heparin Sodium Injection is an aqueous injection.

It contains not less than 90% and not more than 110% of the labeled heparin Units.

Method of preparation Dissolve Heparin Sodium in Isotonic Sodium Chloride Solution and prepare as directed under Injections.

Description Heparin Sodium Injection is a clear, colorless to light yellow liquid.

pH <2.54> 5.5 – 8.0

Purity Barium—Measure exactly a volume of Heparin Sodium Injection, equivalent to 3000 Units of Heparin Sodium, add water to make 3.0 mL and use this solution as the sample solution. To 1.0 mL of the sample solution add 3 drops of dilute sulfuric acid, and allow to stand for 10 minutes: no turbidity is produced.

Bacterial endotoxins <4.01> Less than 0.0030 EU/unit.

Extractable volume <6.05> It meets the requirement.

Foreign insoluble matter <6.06> Perform the test according to Method 1: it meets the requirement.

Insoluble particulate matter <6.07> It meets the requirement.

Sterility <4.06> Perform the test according to the Membrane filtration method: it meets the requirement.

Assay Proceed as directed in the Assay under Heparin Sodium, replacing (vii) Heparin sample solutions and (ix) Calculations with the following.

(vii) Heparin sample solutions: Take exactly an appropriate amount of Heparin Sodium Injection, dilute exactly with buffer solution so that each mL contains 0.1 Heparin Units, and use this solution as the sample solution. Make heparin sample solutions T_1 , T_2 , T_3 and T_4 respectively by adding the sample solution to buffer solution as directed in the following table.

Heparin sample solution		Buffer solution (μL)	Sample solution (μL)
No.	Heparin concentration (Unit/mL)		
T_1	0.005	950	50
T_2	0.010	900	100
T_3	0.015	850	150
T_4	0.020	800	200

(ix) Calculations: When the regression expression, $y = I_c + A_{x_s} + B_{x_t}$, is obtained using y as log of the absorbance values, x_s as the concentration of the heparin standard solutions and x_t as the concentration of the heparin sample solutions, the potency ratio R is B/A .

I_c : Common intercept

A : Slope of regression expression of the heparin standard solution

B : Slope of regression expression of the heparin sample solution

Calculate Heparin Units (anti-factor IIa activity) in 1 mL of Heparin Sodium Injection by the following formula.

Heparin Units (anti-factor IIa activity) in 1 mL of Heparin Sodium Injection

$$= 0.1 \times R \times V/a$$

V : Total volume (mL) of the sample solution prepared as containing 0.1 Heparin Units (anti-factor IIa activity) per mL

a : Amount (mL) of Heparin Sodium Injection taken for the sample solution

However, when a 90% confidence interval of D of the regression expression $y = I'_c + A'_{x_s} + B'_{x_t} + D$, where D is a constant term showing the difference between the intercepts assumed from the measurement of the blank and the two lines, is not in the range of between -0.2 and 0.2 , analyze by excluding the measurements of the blank.

The criteria for the test suitability are followed as directed in the Assay under Heparin Sodium. When these criteria are not satisfied, repeat the test after changing the dilution rate so that the potency ratio becomes about 1 using the obtained potency as reference.

Containers and storage Containers—Hermetic containers.

Storage—Light-resistant.

Heparin Sodium Lock Solution

ロック用ヘパリンナトリウム液

Heparin Sodium Lock Solution is a preparation used to prevent blood coagulation in intravenous indwelling routes.

It contains not less than 90% and not more than 110% of the labeled Heparin Units.

Method of preparation Prepare as directed under Injections, with Heparin Sodium.

Description Heparin Sodium Lock Solution is a clear, colorless to light yellow liquid.

Osmotic pressure ratio: 0.9 – 1.1

pH <2.54> 5.5 – 8.0

Bacterial endotoxins <4.01> Less than 0.0030 EU/unit.

Extractable volume <6.05> It meets the requirement.

Foreign insoluble matter <6.06> Perform the test according to Method 1: it meets the requirement.

Insoluble particulate matter <6.07> It meets the requirement.

Sterility <4.06> Perform the test according to the Membrane filtration method: it meets the requirement.

Assay Proceed as directed in the Assay under Heparin Sodium, replacing (vii) Heparin sample solutions and (ix) Calculations with the following.

(vii) Heparin sample solutions: Pipet a suitable volume of Heparin Sodium Lock Solution, dilute exactly with the buffer solution so that each mL contains 0.1 Heparin Units, and use this solution as the sample solution. Prepare heparin sample solutions T₁, T₂, T₃ and T₄ respectively by adding the sample solution to the buffer solution as directed in the following table.

Heparin sample solution		Buffer solution (μL)	Sample solution (μL)
No.	Heparin concentration (Unit/mL)		
T ₁	0.005	950	50
T ₂	0.010	900	100
T ₃	0.015	850	150
T ₄	0.020	800	200

(ix) Calculations: When the regression expression, $y = I_c + A_{x_s} + B_{x_s}$, is obtained using y as log of the absorbance values, x_s as the concentration of the heparin standard solutions and x_t as the concentration of the heparin sample solutions, the potency ratio R is B/A .

I_c : Common intercept

A : Slope of regression expression of the heparin standard solution

B : Slope of regression expression of the heparin sample solution

Calculate Heparin Units (anti-factor IIa activity) in 1 mL of Heparin Sodium Lock Solution by the following formula.

Heparin Units (anti-factor IIa activity) in 1 mL of Heparin Sodium Lock Solution

$$= 0.1 \times R \times V/a$$

V : Total volume (mL) of the sample solution prepared as containing 0.1 Heparin Units (anti-factor IIa activity) per mL

a : Amount (mL) of Heparin Sodium Lock Solution taken

However, when a 90% confidence interval of D of the regression expression $y = I'_c + A'_{x_s} + B'_{x_s} + D$, where D is a constant term showing the difference between the intercepts assumed from the measurement of the blank and the two lines, is not in the range of between -0.2 and 0.2 , analyze by excluding the measurements of the blank.

The criteria for the test suitability are followed as directed in the Assay under Heparin Sodium. When these criteria are not satisfied, repeat the test after changing the dilution rate so that the potency ratio becomes about 1 using the obtained

potency as reference.

Containers and storage Containers—Hermetic containers. Plastic containers for aqueous injections may be used.

Heparin Sodium Solution for Dialysis

透析用ヘパリンナトリウム液

Heparin Sodium Solution for Dialysis is a preparation used to prevent coagulation of perfused blood during hemodialysis.

It contains not less than 90% and not more than 110% of the labeled Heparin Unit.

Method of preparation Prepare as directed under Injections, with Heparin Sodium.

Description Heparin Sodium Solution for Dialysis is a clear, colorless to light yellow liquid.

Osmotic pressure ratio: 0.9 – 1.1

pH <2.54> 5.5 – 8.0

Bacterial endotoxins <4.01> Less than 0.0030 EU/unit.

Extractable volume <6.05> It meets the requirement.

Foreign insoluble matter <6.06> Perform the test according to Method 1: it meets the requirement.

Insoluble particulate matter <6.07> It meets the requirement.

Sterility <4.06> Perform the test according to the Membrane filtration method: it meets the requirement.

Assay Proceed as directed in the Assay under Heparin Sodium, replacing (vii) Heparin sample solutions and (ix) Calculations with the following.

(vii) Heparin sample solutions: Pipet a suitable volume of Heparin Sodium Solution for Dialysis, dilute exactly with the buffer solution so that each mL contains 0.1 Heparin Units, and use this solution as the sample solution. Prepare heparin sample solutions T₁, T₂, T₃ and T₄ respectively by adding the sample solution to the buffer solution as directed in the following table.

Heparin sample solution		Buffer solution (μL)	Sample solution (μL)
No.	Heparin concentration (Unit/mL)		
T ₁	0.005	950	50
T ₂	0.010	900	100
T ₃	0.015	850	150
T ₄	0.020	800	200

(ix) Calculations: When the regression expression, $y = I_c + A_{x_s} + B_{x_s}$, is obtained using y as log of the absorbance values, x_s as the concentration of the heparin standard solutions and x_t as the concentration of the heparin sample solutions, the potency ratio R is B/A .

I_c : Common intercept

A : Slope of regression expression of the heparin standard solution

B: Slope of regression expression of the heparin sample solution

Calculate Heparin Units (anti-factor IIa activity) in 1 mL of Heparin Sodium Solution for Dialysis by the following formula.

Heparin Units (anti-factor IIa activity) in 1 mL of Heparin Sodium Solution for Dialysis

$$= 0.1 \times R \times V/a$$

V: Total volume (mL) of the sample solution prepared as containing 0.1 Heparin Units (anti-factor IIa activity) per mL

a: Amount (mL) of Heparin Sodium Solution for Dialysis taken

However, when a 90% confidence interval of *D* of the regression expression $y = I'_c + A'_x + B'_x + D$, where *D* is a constant term showing the difference between the intercepts assumed from the measurement of the blank and the two lines, is not in the range of between -0.2 and 0.2, analyze by excluding the measurements of the blank.

The criteria for the test suitability are followed as directed in the Assay under Heparin Sodium. When these criteria are not satisfied, repeat the test after changing the dilution rate so that the potency ratio becomes about 1 using the obtained potency as reference.

Containers and storage Containers—Hermetic containers. Plastic containers for aqueous injections may be used.

Adsorbed Hepatitis B Vaccine

沈降 B 型肝炎ワクチン

Adsorbed Hepatitis B Vaccine is a liquid for injection prepared by adding an aluminum salt to a liquid containing a surface antigen of hepatitis B virus to make the HBs antigen insoluble.

It conforms to the requirements of Adsorbed Hepatitis B Vaccine in the Minimum Requirements for Biological Products.

Description Adsorbed Hepatitis B Vaccine becomes a homogeneous, whitish turbid liquid on shaking.

L-Histidine

L-ヒスチジン

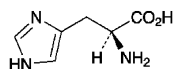

$C_6H_9N_3O_2$: 155.15

(2*S*)-2-Amino-3-(1*H*-imidazol-4-yl)propanoic acid
[71-00-1]

L-Histidine contains not less than 99.0% and not more than 101.0% of L-histidine ($C_6H_9N_3O_2$), calculated on the dried basis.

Description L-Histidine occurs as white, crystals or crystalline powder, having a slight bitter taste.

It is freely soluble in formic acid, and soluble in water, and practically insoluble in ethanol (99.5).

It dissolves in 6 mol/L hydrochloric acid TS.

It shows crystal polymorphism.

Identification Determine the infrared absorption spectrum of L-Histidine as directed in the potassium bromide disk method under Infrared Spectrophotometry <2.25>, and compare the spectrum with the Reference Spectrum: both spectra exhibit similar intensities of absorption at the same wave numbers. If any difference appears between the spectra, dissolve the sample with a little amount of water, evaporate the water at 60°C under reduced pressure, dry the residue, and perform the test.

Optical rotation <2.49> $[\alpha]_D^{20}$: +11.8 – +12.8° (5.5 g calculated on the dried basis, 6 mol/L hydrochloric acid TS, 50 mL, 100 mm).

pH <2.54> The pH of a solution of 1.0 g of L-Histidine in 50 mL of water is between 7.0 and 8.5.

Purity (1) Clarity and color of solution—A solution of 0.40 g of L-Histidine in 20 mL of water is clear and colorless.

(2) Chloride <1.03>—Perform the test with 0.5 g of L-Histidine. Prepare the control solution with 0.30 mL of 0.01 mol/L hydrochloric acid VS (not more than 0.021%).

(3) Sulfate <1.14>—Perform the test with 0.6 g of L-Histidine. Prepare the control solution with 0.35 mL of 0.005 mol/L sulfuric acid VS (not more than 0.028%).

(4) Ammonium <1.02>—Perform the test with 0.25 g of L-Histidine. Prepare the control solution with 5.0 mL of Standard Ammonium Solution (not more than 0.02%).

(5) Heavy metals <1.07>—Dissolve 1.0 g of L-Histidine in 30 mL of water by warming. To this solution add 2.4 mL of dilute hydrochloric acid, 2 mL of dilute acetic acid and water to make 50 mL. Perform the test using this solution as the test solution. Prepare the control solution as follows: To 1.0 mL of Standard Lead Solution add 2 mL of dilute acetic acid and water to make 50 mL (not more than 10 ppm).

(6) Iron <1.10>—Prepare the test solution with 1.0 g of L-Histidine according to Method 1, and perform the test according to Method A. Prepare the control solution with 1.0 mL of Standard Iron Solution (not more than 10 ppm).

(7) Related substances—Dissolve 0.10 g of L-Histidine in 10 mL of water, and use this solution as the sample solution. Pipet 1 mL of the sample solution, add water to make exactly 10 mL. Pipet 1 mL of this solution, add water to make exactly 50 mL, and use this solution as the standard solution. Perform the test with these solutions as directed under Thin-layer Chromatography <2.03>. Spot 5 μ L each of the sample solution and standard solution on a plate of silica gel for thin-layer chromatography, develop the plate with a mixture of 1-propanol and ammonia solution (28) (67:33) to a distance of about 10 cm, and dry the plate at 80°C for 30 minutes. Spray evenly a solution of ninhydrin in a mixture of methanol and acetic acid (100) (97:3) (1 in 100) to the plate, and heat at 80°C for 10 minutes: the spot other than the principal spot obtained from the sample solution is not more intense than the spot from the standard solution.

Loss on drying <2.41> Not more than 0.3% (1 g, 105°C, 3 hours).

Residue on ignition <2.44> Not more than 0.1% (1 g).

Assay Weigh accurately about 0.15 g of L-Histidine, dissolve in 2 mL of formic acid, add 50 mL of acetic acid (100), and titrate <2.50> with 0.1 mol/L perchloric acid VS (potentiometric titration). Perform a blank determination in the same manner, and make any necessary correction.

$$\text{Each mL of 0.1 mol/L perchloric acid VS} \\ = 15.52 \text{ mg of } C_6H_9N_3O_2$$

Containers and storage Containers—Tight containers.

L-Histidine Hydrochloride Hydrate

L-ヒスチジン塩酸塩水和物

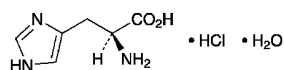

$C_6H_9N_3O_2 \cdot HCl \cdot H_2O$: 209.63
(2*S*)-2-Amino-3-(1*H*-imidazol-4-yl)propanoic acid
monohydrochloride monohydrate
[5934-29-2]

L-Histidine Hydrochloride Hydrate contains not less than 99.0% and not more than 101.0% of L-histidine hydrochloride ($C_6H_9N_3O_2 \cdot HCl$: 191.62), calculated on the anhydrous basis.

Description L-Histidine Hydrochloride Hydrate occurs as white crystals or a white crystalline powder. It has an acid taste at first, and a slight bitter taste later.

It is freely soluble in water and in formic acid, and practically insoluble in ethanol (99.5).

It dissolves in 6 mol/L hydrochloric acid TS.

Identification (1) Determine the infrared absorption spectrum of L-Histidine Hydrochloride Hydrate as directed in the potassium chloride disk method under Infrared Spectrophotometry <2.25>, and compare the spectrum with the Reference Spectrum: both spectra exhibit similar intensities of absorption at the same wave numbers.

(2) A solution of L-Histidine Hydrochloride Hydrate (1 in 10) responds to Qualitative Tests <1.09> for chloride.

Optical rotation <2.49> $[\alpha]_D^{20}$: +9.2 – +10.6° (5.5 g calculated on the anhydrous basis, 6 mol/L hydrochloric acid TS, 50 mL, 100 mm).

pH <2.54> The pH of a solution of 1.0 g of L-Histidine Hydrochloride Hydrate in 10 mL of water is between 3.5 and 4.5.

Purity (1) Clarity and color of solution—A solution of 1.0 g of L-Histidine Hydrochloride Hydrate in 10 mL of water is clear and colorless.

(2) Sulfate <1.14>—Perform the test with 0.6 g of L-Histidine Hydrochloride Hydrate. Prepare the control solution with 0.35 mL of 0.005 mol/L sulfuric acid VS (not more than 0.028%).

(3) Ammonium <1.02>—Perform the test with 0.25 g of L-Histidine Hydrochloride Hydrate. Prepare the control solution with 5.0 mL of Standard Ammonium Solution (not more than 0.02%).

(4) Heavy metals <1.07>—Proceed with 1.0 g of L-Histidine Hydrochloride Hydrate according to Method 1, and perform the test. Prepare the control solution with 1.0 mL of Standard Lead Solution (not more than 10 ppm).

(5) Iron <1.10>—Prepare the test solution with 1.0 g of L-Histidine Hydrochloride Hydrate according to Method 1, and perform the test according to Method A. Prepare the control solution with 1.0 mL of Standard Iron Solution (not more than 10 ppm).

(6) Related substances—Dissolve 0.10 g of L-Histidine Hydrochloride Hydrate in 10 mL of water, and use this solution as the sample solution. Pipet 1 mL of the sample solution, add water to make exactly 10 mL. Pipet 1 mL of this solution, add water to make exactly 50 mL, and use this solution as the standard solution. Perform the test with these solutions as directed under Thin-layer Chromatography

<2.03>. Spot 5 μ L each of the sample solution and standard solution on a plate of silica gel for thin-layer chromatography, develop the plate with a mixture of 1-propanol and ammonia solution (28) (67:33) to a distance of about 10 cm, and dry the plate at 80°C for 30 minutes. Spray evenly a solution of ninhydrin in a mixture of methanol and acetic acid (100) (97:3) (1 in 100) to the plate, and heat the plate at 80°C for 10 minutes: the spot other than the principal spot obtained from the sample solution is not more intense than the spot from the standard solution.

Water <2.48> 7.2 – 10.0% (0.12 g, volumetric titration, direct titration, using a mixture of methanol for water determination and formamide for water determination (2:1) instead of methanol for water determination).

Residue on ignition <2.44> Not more than 0.1% (1 g).

Assay Weigh accurately about 0.1 g of L-Histidine Hydrochloride Hydrate, dissolve in 3 mL of formic acid, add exactly 15 mL of 0.1 mol/L perchloric acid VS, and heat on a water bath for 30 minutes. After cooling, add 45 mL of acetic acid (100), and titrate <2.50> the excess of perchloric acid with 0.1 mol/L sodium acetate VS (potentiometric titration). Perform a blank determination in the same manner.

Each mL of 0.1 mol/L perchloric acid VS
= 9.581 mg of $C_6H_9N_3O_2 \cdot HCl$

Containers and storage Containers—Tight containers.

Homatropine Hydrobromide

ホマトロピン臭化水素酸塩

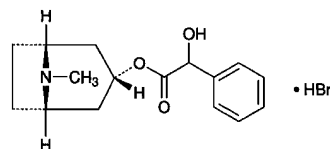

$C_{16}H_{21}NO_3 \cdot HBr$: 356.25
(1*R*,3*r*,5*S*)-8-Methyl-8-azabicyclo[3.2.1]oct-3-yl
[(2*R,S*)-2-hydroxy-2-phenyl]acetate monohydrobromide
[51-56-9]

Homatropine Hydrobromide contains not less than 99.0% of homatropine hydrobromide ($C_{16}H_{21}NO_3 \cdot HBr$), calculated on the dried basis.

Description Homatropine Hydrobromide occurs as white, crystals or crystalline powder. It is odorless.

It is freely soluble in water, sparingly soluble in ethanol (95), slightly soluble in acetic acid (100), very slightly soluble in acetic anhydride, and practically insoluble in diethyl ether.

It is affected by light.

Melting point: about 214°C (with decomposition).

Identification (1) To 5 mL of a solution of Homatropine Hydrobromide (1 in 20) add 2 to 3 drops of iodine TS: a brown precipitate is produced.

(2) Dissolve 0.05 g of Homatropine Hydrobromide in 5 mL of water, and add 3 mL of 2,4,6-trinitrophenol TS: a yellow precipitate is produced. Filter the precipitate, wash with five 10-mL portions of water, and dry at 105°C for 2 hours: it melts <2.60> between 184°C and 187°C.

(3) A solution of Homatropine Hydrobromide (1 in 20) responds to Qualitative Tests <1.09> for bromide.

Purity (1) Acidity—Dissolve 1.0 g of Homatropine

Hydrobromide in 20 mL of water, and add 0.40 mL of 0.01 mol/L sodium hydroxide VS and 1 drop of methyl red-methylene blue TS: a green color develops.

(2) Atropine, hyoscyamine and scopolamine—To 10 mg of Homatropine Hydrobromide add 5 drops of nitric acid, evaporate on a water bath to dryness, and cool. Dissolve the residue in 1 mL of *N,N*-dimethylformamide, and add 5 to 6 drops of tetraethylammonium hydroxide TS: no red-purple color is produced.

(3) Related substances—Dissolve 0.15 g of Homatropine Hydrobromide in 3 mL of water, and use this solution as the sample solution.

(i) To 1 mL of the sample solution add 2 to 3 drops of tannic acid TS: no precipitate is produced.

(ii) To 1 mL of the sample solution add 2 to 3 drops each of dilute hydrochloric acid and platinum chloride TS: no precipitate is produced.

Loss on drying <2.41> Not more than 1.5% (0.5 g, 105°C, 2 hours).

Residue on ignition <2.44> Not more than 0.2% (0.2 g).

Assay Dissolve by warming about 0.4 g of Homatropine Hydrobromide in 60 mL of a mixture of acetic anhydride and acetic acid (100) (7:3). Cool, and titrate <2.50> with 0.1 mol/L perchloric acid VS (potentiometric titration). Perform a blank determination in the same manner, and make any necessary correction.

$$\begin{aligned} \text{Each mL of 0.1 mol/L perchloric acid VS} \\ = 35.63 \text{ mg of } C_{16}H_{21}NO_3 \cdot HBr \end{aligned}$$

Containers and storage Containers—Tight containers.

Storage—Light-resistant.

Homochlorcyclizine Hydrochloride

ホモクロルシクリジン塩酸塩

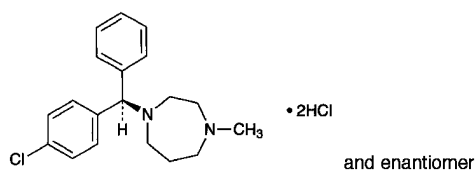

$C_{19}H_{23}ClN_2 \cdot 2HCl$: 387.77

1-[(*RS*)-(4-Chlorophenyl)(phenyl)methyl]-4-methylhexahydro-1*H*-1,4-diazepine dihydrochloride [1982-36-1]

Homochlorcyclizine Hydrochloride, when dried, contains not less than 98.0% of homochlorcyclizine hydrochloride ($C_{19}H_{23}ClN_2 \cdot 2HCl$).

Description Homochlorcyclizine Hydrochloride occurs as white to pale brown, crystals or powder.

It is very soluble in water, freely soluble in acetic acid (100), slightly soluble in ethanol (99.5), and very slightly soluble in acetonitrile and in acetic anhydride.

It dissolves in 0.1 mol/L hydrochloric acid TS.

It is hygroscopic.

It is colored slightly by light.

A solution of Homochlorcyclizine Hydrochloride (1 in 10) shows no optical rotation.

Melting point: about 227°C (with decomposition).

Identification (1) Determine the absorption spectrum of a solution of Homochlorcyclizine Hydrochloride in 0.1 mol/L

hydrochloric acid TS (1 in 100,000) as directed under Ultraviolet-visible Spectrophotometry <2.24>, and compare the spectrum with the Reference Spectrum: both spectra exhibit similar intensities of absorption at the same wavelengths.

(2) Determine the infrared absorption spectrum of Homochlorcyclizine Hydrochloride, previously dried, as directed in the potassium chloride disk method under Infrared Spectrophotometry <2.25>, and compare the spectrum with the Reference Spectrum: both spectra exhibit similar intensities of absorption at the same wave numbers.

(3) A solution of Homochlorcyclizine Hydrochloride (1 in 100) responds to Qualitative Tests <1.09> for chloride.

Purity (1) Heavy metals <1.07>—Proceed with 1.0 g of Homochlorcyclizine Hydrochloride according to Method 2, and perform the test. Prepare the control solution with 2.0 mL of Standard Lead Solution (not more than 20 ppm).

(2) Related substances—Dissolve 0.10 g of Homochlorcyclizine Hydrochloride in 100 mL of the mobile phase, and use this solution as the sample solution. Measure exactly 1 mL of the sample solution, add the mobile phase to make exactly 100 mL, and use this solution as the standard solution. Perform the test with exactly 10 μ L each of the sample solution and standard solution as directed under Liquid Chromatography <2.01> according to the following conditions, and determine the peak areas by the automatic integration method: the areas of the peaks other than homochlorcyclizine obtained from the sample solution are not larger than 1/2 times the peak area of homochlorcyclizine from the standard solution, and the total area of the peaks other than homochlorcyclizine from the sample solution is not larger than the peak area of homochlorcyclizine from the standard solution.

Operating conditions—

Detector: An ultraviolet absorption photometer (wavelength: 223 nm).

Column: A stainless steel column 4.6 mm in inside diameter and 25 cm in length, packed with octadecylsilanized silica gel for liquid chromatography (5 μ m in particle diameter).

Column temperature: A constant temperature of about 40°C.

Mobile phase: A mixture of water, acetonitrile and perchloric acid (134:66:1).

Flow rate: Adjust so that the retention time of homochlorcyclizine is about 10 minutes.

Time span of measurement: About 2 times as long as the retention time of homochlorcyclizine.

System suitability—

Test for required detectability: To exactly 5 mL of the standard solution add the mobile phase to make exactly 50 mL. Confirm that the peak area of homochlorcyclizine obtained with 10 μ L of this solution is equivalent to 7 to 13% of that with 10 μ L of the standard solution.

System performance: Dissolve 5 mg each of Homochlorcyclizine Hydrochloride and methyl parahydroxybenzoic acid in 100 mL of the mobile phase. When the procedure is run with 10 μ L of this solution under the above operating conditions, methyl parahydroxybenzoic acid and homochlorcyclizine are eluted in this order with the resolution between these peaks being not less than 5.

System repeatability: When the test is repeated 6 times with 10 μ L of the standard solution under the above operating conditions, the relative standard deviation of the peak area of homochlorcyclizine is not more than 1.0%.

Loss on drying <2.41> Not more than 2.0% (1 g, 110°C, 4 hours).

Residue on ignition <2.44> Not more than 0.2% (1 g).

Assay Weigh accurately about 0.3 g of Homochlorcyclazine Hydrochloride, previously dried, dissolve in 50 mL of a mixture of acetic anhydride and acetic acid (100) (7:3), and titrate <2.50> with 0.1 mol/L perchloric acid VS (potentiometric titration). Perform a blank determination in the same manner, and make any necessary correction.

Each mL of 0.1 mol/L perchloric acid VS
= 19.39 mg of C₁₉H₂₃ClN₂·2HCl

Containers and storage Containers—Tight containers.
Storage—Light-resistant.

Human Normal Immunoglobulin

人免疫グロブリン

Human Normal Immunoglobulin is a liquid for injection containing immunoglobulin G in serum globulins of humans.

It conforms to the requirements of Human Normal Immunoglobulin in the Minimum Requirements for Biological Products.

Description Human Normal Immunoglobulin is a clear, colorless or yellow-brown liquid.

Hydralazine Hydrochloride

ヒドララジン塩酸塩

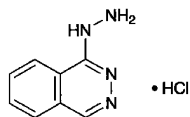

C₈H₈N₄·HCl: 196.64

Phthalazin-1-ylhydrazine monohydrochloride
[304-20-1]

Hydralazine Hydrochloride, when dried, contains not less than 98.0% of hydralazine hydrochloride (C₈H₈N₄·HCl).

Description Hydralazine Hydrochloride occurs as a white crystalline powder. It is odorless, and has a bitter taste.

It is soluble in water, slightly soluble in ethanol (95), and practically insoluble in diethyl ether.

Melting point: about 275°C (with decomposition).

Identification (1) Determine the absorption spectrum of a solution of Hydralazine Hydrochloride (1 in 100,000) as directed under Ultraviolet-visible Spectrophotometry <2.24>, and compare the spectrum with the Reference Spectrum: both spectra exhibit similar intensities of absorption at the same wavelengths.

(2) Determine the infrared absorption spectrum of Hydralazine Hydrochloride, previously dried, as directed in the potassium bromide disk method under Infrared Spectrophotometry <2.25>, and compare the spectrum with the Reference spectrum: both spectra exhibit similar intensities of absorption at the same wave numbers.

(3) A solution of Hydralazine Hydrochloride (1 in 50) responds to Qualitative Tests <1.09> for chloride.

pH <2.54> Dissolve 1.0 g of Hydralazine Hydrochloride in

50 mL of water: the pH of the solution is between 3.5 and 4.5.

Purity (1) Clarity and color of solution—Dissolve 1.0 g of Hydralazine Hydrochloride in 50 mL of water: the solution is clear, and colorless or pale yellow.

(2) Heavy metals <1.07>—Proceed with 1.0 g of Hydralazine Hydrochloride according to Method 2, and perform the test. Prepare the control solution with 2.0 mL of Standard Lead Solution (not more than 20 ppm).

Loss on drying <2.41> Not more than 0.5% (0.5 g, in vacuum, phosphorus (V) oxide, 8 hours).

Residue on ignition <2.44> Not more than 0.1% (1 g).

Assay Weigh accurately about 0.15 g of Hydralazine Hydrochloride, previously dried, transfer it to a glass-stoppered flask, dissolve in 25 mL of water, add 25 mL of hydrochloric acid, cool to room temperature, add 5 mL of chloroform, and titrate <2.50> with 0.05 mol/L potassium iodate VS while shaking until the purple color of the chloroform layer disappears. The end point is reached when the red-purple color no more reappears in the chloroform layer within 5 minutes after the layer has been decolorized.

Each mL of 0.05 mol/L potassium iodate VS
= 9.832 mg of C₈H₈N₄·HCl

Containers and storage Containers—Tight containers.

Hydralazine Hydrochloride for Injection

注射用ヒドララジン塩酸塩

Hydralazine Hydrochloride for Injection is a preparation for injection which is dissolved before use.

It contains not less than 99.0% and not more than 113.0% of the labeled amount of hydralazine hydrochloride (C₈H₈N₄·HCl: 196.64).

Method of preparation Prepare as directed under Injections, with Hydralazine Hydrochloride.

Description Hydralazine Hydrochloride for Injection occurs as a white to pale yellow powder or mass. It is odorless, and has a bitter taste.

Identification Determine the absorption spectrum of a solution of Hydralazine Hydrochloride for Injection (1 in 100,000) as directed under Ultraviolet-visible Spectrophotometry <2.24>: it exhibits maxima between 238 nm and 242 nm, between 258 nm and 262 nm, between 301 nm and 305 nm, and between 313 nm and 317 nm.

pH <2.54> Dissolve 1.0 g of Hydralazine Hydrochloride for Injection in 50 mL of water: the pH of this solution is between 3.5 and 4.5.

Bacterial endotoxins <4.01> Less than 5.0 EU/mg.

Uniformity of dosage units <6.02> It meets the requirement of the Mass variation test. (T: 106.0%)

Foreign insoluble matter <6.06> Perform the test according to Method 2: it meets the requirement.

Insoluble particulate matter <6.07> It meets the requirement.

Sterility <4.06> Perform the test according to the Mem-

brane filtration method: it meets the requirement.

Assay Weigh accurately the contents of not less than 10 samples of Hydralazine Hydrochloride for Injection. Weigh accurately about 0.15 g of the contents, transfer it to a glass-stoppered flask, dissolve in 25 mL of water, add 25 mL of hydrochloric acid, cool to room temperature, and proceed as directed in the Assay under Hydralazine Hydrochloride.

Each mL of 0.05 mol/L potassium iodate VS
= 9.832 mg of $C_8H_8N_4.HCl$

Containers and storage Containers—Hermetic containers.

Hydralazine Hydrochloride Powder

ヒドララジン塩酸塩散

Hydralazine Hydrochloride Powder contains not less than 95.0% and not more than 105.0% of the labeled amount of hydralazine hydrochloride ($C_8H_8N_4.HCl$: 196.64).

Method of preparation Prepare as directed under Granules or Powders, with Hydralazine Hydrochloride.

Identification Weigh a portion of Hydralazine Hydrochloride Powder, equivalent to 25 mg of Hydralazine Hydrochloride, add 100 mL of water, shake well, and filter, if necessary. Add water to 2 mL of this solution to make 50 mL and determine the absorption spectrum of this solution as directed under Ultraviolet-visible Spectrophotometry <2.24>: it exhibits maxima between 238 nm and 242 nm, between 258 nm and 262 nm, between 301 nm and 305 nm, and between 313 nm and 317 nm.

Dissolution <6.10> When the test is performed at 50 revolutions per minute according to the Paddle method, using 900 mL of water as the dissolution medium, the dissolution rate in 15 minutes of Hydralazine Hydrochloride Powder is not less than 85%.

Start the test with an accurately weighed amount of Hydralazine Hydrochloride Powder, equivalent to about 50 mg of hydralazine hydrochloride ($C_8H_8N_4.HCl$), withdraw not less than 10 mL of the medium at the specified minute after starting the test, and filter through a membrane filter with a pore size not exceeding $0.5 \mu m$. Discard not less than 5 mL of the first filtrate, pipet 4 mL of the subsequent filtrate, add water to make exactly 20 mL, and use this solution as the sample solution. Separately, weigh accurately about 28 mg of hydralazine hydrochloride for assay, previously dried at $105^\circ C$ for 3 hours, and dissolve in water to make exactly 50 mL. Pipet 2 mL of this solution, add water to make exactly 100 mL, and use this solution as the standard solution. Determine the absorbances, A_T and A_S , at 260 nm of the sample solution and standard solution as directed under Ultraviolet-visible Spectrophotometry <2.24>.

Dissolution rate (%) with respect to the labeled amount of hydralazine hydrochloride ($C_8H_8N_4.HCl$)
= $M_S/M_T \times A_T/A_S \times 1/C \times 180$

M_S : Amount (mg) of hydralazine hydrochloride for assay taken

M_T : Amount (g) of the Hydralazine Hydrochloride Powder taken

C : Labeled amount (mg) of hydralazine hydrochloride ($C_8H_8N_4.HCl$) in 1 g

Assay Weigh accurately a portion of Hydralazine Hydro-

chloride Powder, equivalent to about 0.15 g of hydralazine hydrochloride ($C_8H_8N_4.HCl$), transfer it to a glass-stoppered flask, add 25 mL of water, shake well, add 25 mL of hydrochloric acid, cool to room temperature, and proceed as directed in the Assay under Hydralazine Hydrochloride.

Each mL of 0.05 mol/L potassium iodate VS
= 9.832 mg of $C_8H_8N_4.HCl$

Containers and storage Containers—Tight containers.

Hydralazine Hydrochloride Tablets

ヒドララジン塩酸塩錠

Hydralazine Hydrochloride Tablets contain not less than 95.0% and not more than 105.0% of the labeled amount of hydralazine hydrochloride ($C_8H_8N_4.HCl$: 196.64).

Method of preparation Prepare as directed under Tablets, with Hydralazine Hydrochloride.

Identification Weigh a quantity of powdered Hydralazine Hydrochloride Tablets, equivalent to 25 mg of Hydralazine Hydrochloride, add 100 mL of water, mix well, and filter if necessary. To 2 mL of this solution add water to make 50 mL, and determine the absorption spectrum of this solution as directed under Ultraviolet-visible Spectrophotometry <2.24>: it exhibits maxima between 238 nm and 242 nm, between 258 nm and 262 nm, between 301 nm and 305 nm and between 313 nm and 317 nm.

Uniformity of dosage units <6.02> Perform the test according to the following method: it meets the requirement of the Content uniformity test.

To 1 tablet of Hydralazine Hydrochloride Tablets add 25 mL of 0.1 mol/L hydrochloric acid TS, disperse the tablet into a small particles by sonicating, then shake well, add 0.1 mol/L hydrochloric acid TS to make exactly 50 mL, and centrifuge. Pipet V mL of the supernatant liquid, add 0.1 mol/L hydrochloric acid TS to make exactly V' mL so that each mL contains about $10 \mu g$ of hydralazine hydrochloride ($C_8H_8N_4.HCl$), and use this solution as the sample solution. Separately, weigh accurately about 25 mg of hydralazine hydrochloride for assay, previously dried at $105^\circ C$ for 3 hours, dissolve in 0.1 mol/L hydrochloric acid TS to make exactly 50 mL. Pipet 2 mL of this solution, add 0.1 mol/L hydrochloric acid TS to make exactly 100 mL, and use this solution as the standard solution. Determine the absorbances at 260 nm, A_{T1} and A_{S1} , and at 350 nm, A_{T2} and A_{S2} , of the sample solution and standard solution as directed under Ultraviolet-visible Spectrophotometry <2.24>.

Amount (mg) of hydralazine hydrochloride ($C_8H_8N_4.HCl$)
= $M_S \times (A_{T1} - A_{T2}) / (A_{S1} - A_{S2}) \times V'/V \times 1/50$

M_S : Amount (mg) of hydralazine hydrochloride for assay taken

Dissolution <6.10> When the test is performed at 50 revolutions per minute according to the Paddle method, using 900 mL of water as the dissolution medium, the dissolution rate in 45 minutes of Hydralazine Hydrochloride Tablets is not less than 80%.

Start the test with 1 tablet of Hydralazine Hydrochloride Tablets, withdraw not less than 20 mL of the medium at the specified minute after starting the test, and filter through a membrane filter with a pore size not exceeding $0.8 \mu m$.

Discard not less than 10 mL of the first filtrate, pipet V mL of the subsequent filtrate, add water to make exactly V' mL so that each mL contains about 11 μg of hydralazine hydrochloride ($\text{C}_8\text{H}_8\text{N}_4\cdot\text{HCl}$), and use this solution as the sample solution. Separately, weigh accurately about 50 mg of hydralazine hydrochloride for assay, previously dried at 105°C for 3 hours, and dissolve in water to make exactly 50 mL. Pipet 1 mL of this solution, add water to make exactly 100 mL, and use this solution as the standard solution. Determine the absorbances, A_T and A_S , of the sample solution and standard solution at 260 nm as directed under Ultraviolet-visible Spectrophotometry <2.24>.

Dissolution rate (%) with respect to the labeled amount of hydralazine hydrochloride ($\text{C}_8\text{H}_8\text{N}_4\cdot\text{HCl}$)

$$= M_S \times A_T / A_S \times V' / V \times 1 / C \times 18$$

M_S : Amount (mg) of hydralazine hydrochloride for assay taken

C : Labeled amount (mg) of hydralazine hydrochloride ($\text{C}_8\text{H}_8\text{N}_4\cdot\text{HCl}$) in 1 tablet

Assay Weigh accurately not less than 20 Hydralazine Hydrochloride Tablets, and powder. Weigh accurately a portion of the powder, equivalent to about 0.15 g of hydralazine hydrochloride ($\text{C}_8\text{H}_8\text{N}_4\cdot\text{HCl}$), transfer it to a glass-stoppered flask, and proceed as directed in the Assay under Hydralazine Hydrochloride.

Each mL of 0.05 mol/L potassium iodate VS
= 9.832 mg of $\text{C}_8\text{H}_8\text{N}_4\cdot\text{HCl}$

Containers and storage Containers—Tight containers.

Hydrochloric Acid

塩酸

Hydrochloric Acid contains not less than 35.0% and not more than 38.0% of hydrogen chloride (HCl: 36.46).

Description Hydrochloric Acid is a colorless liquid having a pungent odor.

It is fuming but ceases to fume when it is diluted with 2 volumes of water.

Specific gravity d_{20}^{20} : about 1.18.

Identification (1) Allow a glass stick wet with ammonia TS to come near the surface of Hydrochloric Acid: a remarkable white smoke evolves.

(2) A solution of Hydrochloric Acid (1 in 100) changes blue litmus paper to red, and responds to Qualitative Tests <1.09> for chloride.

Purity (1) Sulfate <1.14>—To 15 mL of Hydrochloric Acid add water to make 50 mL, and use this solution as the sample solution. To 3.0 mL of the sample solution add 5 mL of water and 5 drops of barium chloride TS, and allow to stand for 1 hour: no turbidity is produced.

(2) Sulfite—To 3.0 mL of the sample solution obtained in (1) add 5 mL of water and 1 drop of iodine TS: the color of iodine TS does not disappear.

(3) Bromide or iodide—Place 10 mL of the sample solution obtained in (1) in a glass-stoppered test tube, add 1 mL of chloroform and 1 drop of 0.002 mol/L potassium permanganate VS, and shake well: the chloroform layer remains colorless.

(4) Bromine or chlorine—Place 10 mL of the sample so-

lution obtained in (1) in a glass-stoppered test tube, add 5 drops of potassium iodide TS and 1 mL of chloroform, and shake for 1 minute: the chloroform layer remains free from a purple color.

(5) Heavy metals <1.07>—Evaporate 5 mL of Hydrochloric Acid on a water bath to dryness, and add 2 mL of dilute acetic acid and water to the residue to make 50 mL. Perform the test using this solution as the test solution. Prepare the control solution as follows: to 3.0 mL of Standard Lead Solution add 2 mL of dilute acetic acid and water to make 50 mL (not more than 5 ppm).

(6) Arsenic <1.11>—Prepare the test solution with 1.7 mL of Hydrochloric Acid according to Method 1, and perform the test (not more than 1 ppm).

(7) Mercury—Dilute 20 mL of Hydrochloric Acid with water to make exactly 100 mL, and use the solution as the sample solution. Perform the test with the sample solution as directed under Atomic Absorption Spectrophotometry <2.23> (cold vapor type). Place the sample solution in a sample bottle of the atomic absorption spectrophotometer, add 10 mL of tin (II) chloride-sulfuric acid TS, connect the bottle immediately to the spectrophotometer, circulate air, and determine the absorbance A_T of the sample solution after the recorder reading has risen rapidly, and becomes constant at a wavelength of 253.7 nm. On the other hand, to 8 mL of Standard Mercury Solution add water to make exactly 100 mL, and determine the absorbance A_S of the solution obtained by the same procedure as used for the sample solution: A_T is smaller than A_S (not more than 0.04 ppm).

Residue on ignition <2.44> Pipet 10 mL of Hydrochloric Acid, add 2 drops of sulfuric acid, evaporate to dryness, and ignite: not more than 1.0 mg of residue remains.

Assay Weigh accurately a glass-stoppered flask containing 20 mL of water, add about 3 mL of Hydrochloric Acid, and weigh accurately again. Dilute with 25 mL of water, and titrate <2.50> with 1 mol/L sodium hydroxide VS (indicator: 2 to 3 drops of methyl red TS).

Each mL of 1 mol/L sodium hydroxide VS
= 36.46 mg of HCl

Containers and storage Containers—Tight containers.

Dilute Hydrochloric Acid

希塩酸

Dilute Hydrochloric Acid contains not less than 9.5 w/v% and not more than 10.5 w/v% of hydrogen chloride (HCl: 36.46).

Description Dilute Hydrochloric Acid is a colorless liquid. It is odorless and has a strong acid taste.

Specific gravity d_{20}^{20} : about 1.05.

Identification A solution of Dilute Hydrochloric Acid (1 in 30) changes blue litmus paper to red and responds to Qualitative Tests <1.09> for chloride.

Purity (1) Sulfate—To 3.0 mL of Dilute Hydrochloric Acid add 5 mL of water and 5 drops of barium chloride TS, and allow to stand for 1 hour: no turbidity is produced.

(2) Sulfite—To 3.0 mL of Dilute Hydrochloric Acid add 5 mL of water and 1 drop of iodine TS: the color of iodine TS does not disappear.

(3) Bromide or iodide—Place 10 mL of Dilute Hydrochloric Acid in a glass-stoppered test tube, add 1 mL of chlo-

roform and 1 drop of 0.002 mol/L potassium permanganate VS, and shake well: the chloroform layer remains colorless.

(4) Bromine or chlorine—Place 10 mL of Dilute Hydrochloric Acid in a glass-stoppered test tube, add 5 drops of potassium iodide TS and 1 mL of chloroform, and shake for 1 minute: the chloroform layer remains free from a purple color.

(5) Heavy metals <1.07>—Evaporate 9.5 mL of Dilute Hydrochloric Acid on a water bath to dryness, add 2 mL of dilute acetic acid and water to make 50 mL, and perform the test using this solution as the test solution. Prepare the control solution as follows: to 3.0 mL of Standard Lead Solution add 2 mL of dilute acetic acid and water to make 50 mL (not more than 3 ppm).

(6) Arsenic <1.11>—Prepare the test solution with 4.0 mL of Dilute Hydrochloric Acid according to Method 1, and perform the test (not more than 0.5 ppm).

(7) Mercury—Dilute 80 mL of Dilute Hydrochloric Acid with water to make exactly 100 mL, and use this solution as the sample solution. Perform the test with the sample solution as directed under Atomic Absorption Spectrophotometry <2.23> (cold vapor type). Place the sample solution in a sample bottle of the atomic absorption spectrophotometer, add 10 mL of tin (II) chloride-sulfuric acid TS, connect the bottle immediately to the spectrophotometer, circulate air, and determine the absorbance A_T of the sample solution after the recorder reading has risen rapidly and become constant at a wavelength of 253.7 nm. On the other hand, to 8 mL of Standard Mercury Solution add water to make exactly 100 mL, and determine the absorbance A_S of the solution obtained by the same procedure as used for the sample solution: A_T is smaller than A_S (not more than 0.01 ppm).

Residue on ignition <2.44> Pipet 10 mL of Dilute Hydrochloric Acid, add 2 drops of sulfuric acid, evaporate to dryness, and ignite: the mass of the residue is not more than 1.0 mg.

Assay Measure exactly 10 mL of Dilute Hydrochloric Acid, and dilute with 20 mL of water. Titrate <2.50> with 1 mol/L sodium hydroxide VS (indicator: 2 to 3 drops of methyl red TS).

Each mL of 1 mol/L sodium hydroxide VS
= 36.46 mg of HCl

Containers and storage Containers—Tight containers.

Hydrochloric Acid Lemonade

塩酸リモナーデ

Method of preparation

Dilute Hydrochloric Acid	5 mL
Simple Syrup	80 mL
Purified Water or Purified Water in Containers	a sufficient quantity
To make 1000 mL	

Prepare before use as directed under Lemonades, with the above ingredients.

Description Hydrochloric Acid Lemonade is a clear, colorless liquid. It has a sweet, cool, acid taste.

Containers and storage Containers—Tight containers.

Hydrochlorothiazide

ヒドロクロロチアジド

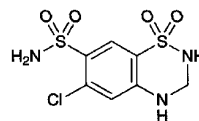

$C_7H_8ClN_3O_4S_2$: 297.74

6-Chloro-3,4-dihydro-2H-1,2,4-benzothiadiazine-7-sulfonamide 1,1-dioxide
[58-93-5]

Hydrochlorothiazide, when dried, contains not less than 99.0% of hydrochlorothiazide ($C_7H_8ClN_3O_4S_2$).

Description Hydrochlorothiazide occurs as white, crystals or crystalline powder. It is odorless, and has a slightly bitter taste.

It is freely soluble in acetone, sparingly soluble in acetonitrile, very slightly soluble in water and in ethanol (95), and practically insoluble in diethyl ether.

It dissolves in sodium hydroxide TS.

Melting point: about 267°C (with decomposition).

Identification (1) To 5 mg of Hydrochlorothiazide add 5 mL of chromotropic acid TS, and allow to stand for 5 minutes: a purple color develops.

(2) Fuse a mixture of 0.1 g of Hydrochlorothiazide and 0.5 g of sodium carbonate decahydrate cautiously: the gas evolved changes moistened red litmus paper to blue. After cooling, crush with a glass rod, add 10 mL of water, stir, and filter. To 4 mL of the filtrate add 2 drops of hydrogen peroxide (30), 5 mL of diluted hydrochloric acid (1 in 5) and 2 to 3 drops of barium chloride TS: a white precipitate is produced.

(3) To 4 mL of the filtrate obtained in (2) add 5 mL of dilute nitric acid and 3 drops of silver nitrate TS: a white precipitate is produced.

(4) Dissolve 12 mg of Hydrochlorothiazide in 100 mL of sodium hydroxide TS. Dilute 10 mL of the solution with water to make 100 mL. Determine the absorption spectrum of the solution as directed under Ultraviolet-visible Spectrophotometry <2.24>, and compare the spectrum with the Reference Spectrum or the spectrum of a solution of Hydrochlorothiazide RS prepared in the same manner as the sample solution: both spectra exhibit similar intensities of absorption at the same wavelengths.

Purity (1) Chloride <1.03>—Dissolve 1.0 g of Hydrochlorothiazide in 30 mL of acetone, add 6 mL of dilute nitric acid and water to make 50 mL, and perform the test using this solution as the test solution. Prepare the control solution as follows: to 1.0 mL of 0.01 mol/L hydrochloric acid VS add 30 mL of acetone, 6 mL of dilute nitric acid and water to make 50 mL (not more than 0.036%).

(2) Sulfate <1.14>—Dissolve 1.0 g of Hydrochlorothiazide in 30 mL of acetone, add 1 mL of dilute hydrochloric acid and water to make 50 mL, and perform the test using this solution as the test solution. Prepare the control solution as follows: to 1.0 mL of 0.005 mol/L sulfuric acid VS add 30 mL of acetone, 1 mL of dilute hydrochloric acid and water to make 50 mL (not more than 0.048%).

(3) Heavy metals <1.07>—Proceed with 1.0 g of Hydrochlorothiazide according to Method 2, and perform the test. Prepare the control solution with 2.0 mL of Standard Lead Solution (not more than 20 ppm).

(4) Primary aromatic amines—Dissolve 80 mg of Hydrochlorothiazide in acetone to make exactly 100 mL. Measure exactly 1 mL of the solution, add 3.0 mL of dilute hydrochloric acid, 3.0 mL of water and 0.15 mL of sodium nitrite TS, shake, and allow to stand for 1 minute. Shake this solution with 1.0 mL of ammonium amidosulfate TS, allow to stand for 3 minutes, then add 1.0 mL of *N,N*-diethyl-*N'*-1-naphthylenediamine oxalate TS, shake, and allow to stand for 5 minutes. Perform the test with this solution as directed under Ultraviolet-visible Spectrophotometry <2.24>, using a solution prepared with 1.0 mL of acetone in the same manner as the blank: the absorbance at 525 nm is not more than 0.10.

Loss on drying <2.41> Not more than 1.0% (1 g, 105°C, 2 hours).

Residue on ignition <2.44> Not more than 0.1% (1 g).

Assay Weigh accurately about 30 mg each of Hydrochlorothiazide and Hydrochlorothiazide RS, previously dried, and dissolve in 150 mL of the mobile phase, add exactly 10 mL each of the internal standard solution, then add the mobile phase to make 200 mL, and use these solutions as the sample solution and the standard solution, respectively. Perform the test with 20 μ L each of the sample solution and standard solution as directed under Liquid Chromatography <2.01> according to the following conditions, and calculate the ratios, Q_T and Q_S , of the peak area of hydrochlorothiazide to that of the internal standard.

$$\begin{aligned} &\text{Amount (mg) of hydrochlorothiazide (C}_7\text{H}_8\text{ClN}_3\text{O}_4\text{S}_2) \\ &= M_S \times Q_T / Q_S \end{aligned}$$

M_S : Amount (mg) of Hydrochlorothiazide RS taken

Internal standard solution—A solution of 4-aminoacetophenone in acetonitrile (9 in 2000).

Operating conditions—

Detector: An ultraviolet absorption photometer (wavelength: 254 nm).

Column: A stainless steel column 4.6 mm in inside diameter and 25 cm in length, packed with octadecylsilanized silica gel for liquid chromatography (5 μ m in particle diameter).

Column temperature: A constant temperature of about 25°C.

Mobile phase: A mixture of 0.1 mol/L sodium dihydrogen phosphate TS (pH 3.0) and acetonitrile (9:1).

Flow rate: Adjust so that the retention time of hydrochlorothiazide is about 10 minutes.

System suitability—

System performance: When the procedure is run with 20 μ L of the standard solution under the above operating conditions, hydrochlorothiazide and the internal standard are eluted in this order with the resolution between these peaks being not less than 4.

System repeatability: When the test is repeated 6 times with 20 μ L of the standard solution under the above operating conditions, the relative standard deviation of the ratios of the peak area of hydrochlorothiazide to that of the internal standard is not more than 1.0%.

Containers and storage Containers—Well-closed containers.

Hydrocortisone

ヒドロコルチゾン

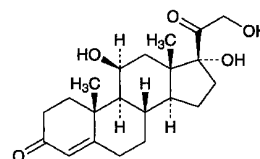

$C_{21}H_{30}O_5$: 362.46

11 β ,17,21-Trihydroxypregn-4-ene-3,20-dione
[50-23-7]

Hydrocortisone, when dried, contains not less than 97.0% and not more than 102.0% of hydrocortisone ($C_{21}H_{30}O_5$).

Description Hydrocortisone occurs as a white crystalline powder.

It is sparingly soluble in methanol and in ethanol (99.5), and very slightly soluble in water.

Melting point: 212 – 220°C (with decomposition).

It shows crystal polymorphism.

Identification (1) Add 2 mL of sulfuric acid to 2 mg of Hydrocortisone: the solution shows a yellow-green fluorescence immediately, and the color of the solution changes gradually from orange to dark red. Dilute carefully the solution with 10 mL of water: the color changes through yellow to orange-yellow with green fluorescence, and a small amount of a flocculent precipitate is formed.

(2) Dissolve 0.01 g of Hydrocortisone in 1 mL of methanol, add 1 mL of Fehling's TS, and heat: a red precipitate is formed.

(3) Determine the infrared absorption spectrum of Hydrocortisone, previously dried, as directed in the potassium bromide disk method under Infrared Spectrophotometry <2.25>, and compare the spectrum with the Reference Spectrum or the spectrum of previously dried Hydrocortisone RS: both spectra exhibit similar intensities of absorption at the same wave numbers. If any difference appears between the spectra, dissolve Hydrocortisone and Hydrocortisone RS in ethanol (95), respectively, then evaporate the ethanol to dryness, and repeat the test on the residues.

Optical rotation <2.49> $[\alpha]_D^{25}$: +160 – +170° (after drying, 0.1 g, ethanol (99.5), 10 mL, 100 mm).

Purity Related substances—Dissolve 20 mg of Hydrocortisone in 10 mL of a mixture of chloroform and methanol (9:1), and use this solution as the sample solution. Pipet 1 mL of the sample solution, add a mixture of chloroform and methanol (9:1) to make exactly 50 mL, and use this solution as the standard solution. Perform the test with these solutions as directed under Thin-layer Chromatography <2.03>. Spot 10 μ L each of the sample solution and standard solution on a plate of silica gel with fluorescent indicator for thin-layer chromatography. Develop the plate with a mixture of chloroform and ethanol (95) (17:3) to a distance of about 10 cm, and air-dry the plate. Examine under ultraviolet light (main wavelength: 254 nm): the spots other than the principal spot obtained from the sample solution are not more intense than the spot from the standard solution.

Loss on drying <2.41> Not more than 1.0% (0.5 g, 105°C, 3 hours).

Residue on ignition <2.44> Not more than 0.1% (0.5 g).

Assay Dissolve about 20 mg each of Hydrocortisone and Hydrocortisone RS, previously dried and accurately weighed, in 20 mL each of a mixture of chloroform and methanol (9:1), add 10 mL each of the internal standard solution, then add a mixture of chloroform and methanol (9:1) to make 50 mL, and use these solutions as the sample solution and standard solution. Perform the test with 5 μ L each of these solutions as directed under Liquid Chromatography <2.01> according to the following conditions, and calculate the ratios, Q_T and Q_S , of the peak area of hydrocortisone to that of the internal standard, respectively.

Amount (mg) of hydrocortisone ($C_{21}H_{30}O_5$) = $M_S \times Q_T/Q_S$

M_S : Amount (mg) of Hydrocortisone RS taken

Internal standard solution—A solution of prednisone in a mixture of chloroform and methanol (9:1) (9 in 10,000).

Operating conditions—

Detector: An ultraviolet absorption photometer (wavelength: 254 nm).

Column: A stainless steel column 4.6 mm in inside diameter and 25 cm in length, packed with silica gel for liquid chromatography (5 μ m in particle diameter).

Column temperature: A constant temperature of about 20°C.

Mobile phase: A mixture of chloroform, methanol and acetic acid (100) (1000:20:1).

Flow rate: Adjust so that the retention time of hydrocortisone is about 15 minutes.

System suitability—

System performance: When the procedure is run with 5 μ L of the standard solution under the above operating conditions, the internal standard and hydrocortisone are eluted in this order with the resolution between these peaks being not less than 7.

System repeatability: When the test is repeated 6 times with 5 μ L of the standard solution under the above operating conditions, the relative standard deviation of the ratios of the peak area of hydrocortisone to that of the internal standard is not more than 1.0%.

Containers and storage Containers—Tight containers.

Hydrocortisone Acetate

ヒドロコルチゾン酢酸エステル

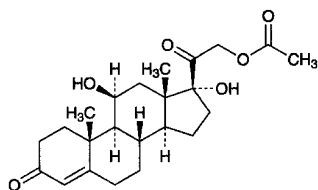

$C_{23}H_{32}O_6$: 404.50

11 β ,17,21-Trihydroxypregn-4-ene-3,20-dione 21-acetate
[50-03-3]

Hydrocortisone Acetate, when dried, contains not less than 97.0% and not more than 102.0% of hydrocortisone acetate ($C_{23}H_{32}O_6$).

Description Hydrocortisone Acetate occurs as white, crystals or crystalline powder.

It is freely soluble in dimethylsulfoxide, slightly soluble in methanol and in ethanol (95), and practically insoluble in water.

Melting point: about 220°C (with decomposition).

It shows crystal polymorphism.

Identification (1) Add 2 mL of sulfuric acid to 2 mg of Hydrocortisone Acetate: the solution shows a yellowish green fluorescence immediately, and the color of the solution gradually changes through orange-yellow to dark red. This solution shows a strong light green fluorescence under ultraviolet light. Add carefully 10 mL of water to this solution: the color changes from yellow to orange-yellow with a light green fluorescence, and a yellow-brown, flocculent precipitate is formed.

(2) Dissolve 0.01 g of Hydrocortisone Acetate in 1 mL of methanol by warming, add 1 mL of Fehling's TS, and heat: an orange to red precipitate is formed.

(3) To 0.05 g of Hydrocortisone Acetate add 2 mL of potassium hydroxide-ethanol TS, and heat on a water bath for 5 minutes. Cool, add 2 mL of diluted sulfuric acid (2 in 7), and boil gently for 1 minute: the odor of ethyl acetate is perceptible.

(4) Determine the infrared absorption spectra of Hydrocortisone Acetate and Hydrocortisone Acetate RS, previously dried, as directed in the potassium bromide disk method under Infrared Spectrophotometry <2.25>: both the sample and the RS exhibit similar intensities of absorption at the same wave numbers. If any difference appears, dissolve the sample and the Reference Standard in ethanol (95), respectively, evaporate to dryness, and repeat the test on the residues.

Optical rotation <2.49> $[\alpha]_D^{25}$: +154 – +164° (after drying, 50 mg, dimethylsulfoxide, 10 mL, 100 mm).

Purity Related substances—Dissolve 40 mg of Hydrocortisone Acetate in 25 mL of a mixture of chloroform and methanol (9:1), and use this solution as the sample solution. Pipet 2 mL of the sample solution, add a mixture of chloroform and methanol (9:1) to make exactly 100 mL, and use this solution as the standard solution. Perform the test with these solutions as directed under Thin-layer Chromatography <2.03>. Spot 5 μ L each of the sample solution and standard solution on a plate of silica gel for thin-layer chromatography. Develop the plate with a mixture of dichloromethane, diethyl ether, methanol and water (160:30:8:1) to a distance of about 12 cm, and air-dry the plate. Spray evenly alkaline blue tetrazolium TS on the plate: the spots other than the principal spot obtained from the sample solution are not more intense than the spot from the standard solution.

Loss on drying <2.41> Not more than 1.0% (0.5 g, 105°C, 3 hours).

Residue on ignition <2.44> Not more than 0.1% (0.5 g).

Assay Dissolve about 20 mg each of Hydrocortisone Acetate and Hydrocortisone Acetate RS, previously dried and accurately weighed, in methanol, add exactly 10 mL each of the internal standard solution, then add methanol to make 100 mL, and use these solutions as the sample solution and standard solution. Perform the test with 20 μ L each of the sample solution and standard solution as directed under Liquid Chromatography <2.01> according to the following conditions, and calculate the ratios, Q_T and Q_S , of the peak area of hydrocortisone acetate to that of the internal standard, respectively.

Amount (mg) of hydrocortisone acetate ($C_{23}H_{32}O_6$)
= $M_S \times Q_T/Q_S$

M_S : Amount (mg) of Hydrocortisone Acetate RS taken

Internal standard solution—A solution of benzyl parahydroxybenzoate in methanol (1 in 1000).

Operating conditions—

Detector: An ultraviolet absorption photometer (wavelength: 254 nm).

Column: A stainless steel column 3.9 mm in inside diameter and 30 cm in length, packed with octadecylsilanized silica gel for liquid chromatography (10 μ m in particle diameter).

Column temperature: A constant temperature of about 25°C.

Mobile phase: A mixture of water and acetonitrile (13:7).

Flow rate: Adjust so that the retention time of hydrocortisone acetate is about 8 minutes.

System suitability—

System performance: When the procedure is run with 20 μ L of the standard solution under the above operating conditions, hydrocortisone acetate and the internal standard are eluted in this order with the resolution between these peaks being not less than 4.

System repeatability: When the test is repeated 6 times with 20 μ L of the standard solution under the above operating conditions, the relative standard deviation of the ratios of the peak area of hydrocortisone acetate to that of the internal standard is not more than 1.0%.

Containers and storage Containers—Tight containers.

Hydrocortisone and Diphenhydramine Ointment

ヒドロコルチゾン・ジフェンヒドラミン軟膏

Method of preparation

Hydrocortisone Acetate	5 g
Diphenhydramine	5 g
White Petrolatum	a sufficient quantity
To make 1000 g	

Prepare as directed under Ointments, with the above ingredients.

Description Hydrocortisone and Diphenhydramine Ointment is white to pale yellow in color.

Identification (1) To 1 g of Hydrocortisone and Diphenhydramine Ointment add 10 mL of ethanol (95), heat on a water bath for 5 minutes with occasional shaking, cool, and filter. Take 5 mL of the filtrate, distill off the ethanol, and to the residue add 2 mL of sulfuric acid: the solution shows a yellow-green fluorescence immediately and the color of the solution gradually changes through yellow to yellow-brown. Add carefully 10 mL of water to this solution: the color changes to yellow with green fluorescence, and a light yellow, flocculent precipitate is formed (hydrocortisone acetate).

(2) To 1 mL of the filtrate obtained in (1) add 5 mL of potassium hydrogen phthalate buffer solution (pH 4.6) and 2 mL of bromophenol blue TS, and add further 5 mL of chloroform. Shake well, and allow to stand: a yellow color develops in the chloroform layer (diphenhydramine).

(3) To 0.2 g of Hydrocortisone and Diphenhydramine Ointment add 0.5 mL of methanol, warm, and shake. After cooling, separate the methanol layer, and use this layer as the sample solution. Dissolve 10 mg each of hydrocortisone acetate and diphenhydramine in 10 mL each of methanol, and use these solutions as standard solutions (1) and (2).

Perform the test with these solutions as directed under Thin-layer Chromatography <2.03>. Spot 5 μ L each of the sample solution and standard solutions (1) and (2) on a plate of silica gel with fluorescent indicator for thin-layer chromatography. Develop the plate with a mixture of ethyl acetate and diethyl ether (4:1) to a distance of about 5 cm, and air-dry the plate. Examine under ultraviolet light (main wavelength: 254 nm): two spots obtained from the sample solution show the same Rf value as the corresponding spots from standard solutions (1) and (2).

Containers and storage Containers—Tight containers.

Storage—Light-resistant.

Hydrocortisone Butyrate

ヒドロコルチゾン酪酸エステル

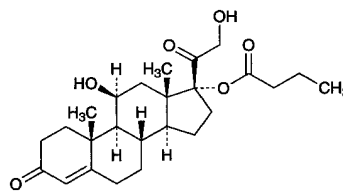

$C_{25}H_{36}O_6$: 432.55

11 β ,17,21-Trihydroxypregn-4-ene-3,20-dione 17-butanoate [13609-67-1]

Hydrocortisone Butyrate, when dried, contains not less than 96.0% and not more than 104.0% of hydrocortisone butyrate ($C_{25}H_{36}O_6$).

Description Hydrocortisone Butyrate occurs as a white powder. It is odorless.

It is freely soluble in chloroform, soluble in methanol, sparingly soluble in ethanol (99.5) and practically insoluble in water.

Melting point: about 200°C (with decomposition).

Identification (1) Add 2 mL of sulfuric acid to 2 mg of Hydrocortisone Butyrate: the solution shows a yellowish green fluorescence immediately, and the color of the solution gradually changes through orange-yellow to dark red. This solution shows a strong light green fluorescence under ultraviolet light (main wavelength: 254 nm). Add carefully 10 mL of water to this solution: the color changes from yellow to orange-yellow with a light green fluorescence, and a yellow-brown, flocculent precipitate is formed.

(2) Dissolve 0.01 g of Hydrocortisone Butyrate in 1 mL of methanol by warming, add 1 mL of Fehling's TS, and heat: an orange to red precipitate is formed.

(3) To 50 mg of Hydrocortisone Butyrate add 2 mL of potassium hydroxide-ethanol TS, and heat on a water bath for 5 minutes. Cool, add 2 mL of diluted sulfuric acid (2 in 7), and boil gently for 1 minute: the odor of ethyl butyrate is perceptible.

(4) Determine the infrared absorption spectrum of Hydrocortisone Butyrate, previously dried, as directed in the potassium bromide disk method under Infrared Spectrophotometry <2.25>, and compare the spectrum with the Reference Spectrum: both spectra exhibit similar intensities of absorption at the same wave numbers.

Optical rotation <2.49> $[\alpha]_D^{25}$: +48 – +52° (after drying, 0.1 g, chloroform, 10 mL, 100 mm).

Purity (1) Heavy metals <1.07>—Proceed with 1.0 g of

Hydrocortisone Butyrate according to Method 2, and perform the test. Prepare the control solution with 2.0 mL of Standard Lead Solution (not more than 20 ppm).

(2) Related substances—Dissolve 50 mg of Hydrocortisone Butyrate in 50 mL of a mixture of acetonitrile and the mobile phase A (4:1), and use this solution as the sample solution. Pipet 1 mL of the sample solution, add a mixture of acetonitrile and the mobile phase A (4:1) to make exactly 100 mL, and use this solution as the standard solution. Perform the test with exactly 5 μ L each of the sample solution and standard solution as directed under Liquid Chromatography <2.01> according to the following conditions. Determine each peak area by the automatic integration method: the area of the peak other than hydrocortisone butyrate obtained from the sample solution is not larger than the peak area of hydrocortisone butyrate from the standard solution, and the total area of the peaks other than hydrocortisone butyrate from the sample solution is not larger than 2 times the peak area of hydrocortisone butyrate from the standard solution.

Operating conditions—

Detector: An ultraviolet absorption photometer (wavelength: 254 nm).

Column: A stainless steel column 4.6 mm in inside diameter and 10 cm in length, packed with octadecylsilanized silica gel for liquid chromatography (3 μ m in particle diameter).

Column temperature: A constant temperature of about 25°C.

Mobile phase A: Dissolve 1 g of potassium dihydrogen phosphate in 1000 mL of water, and adjust to pH 5.5 with potassium hydroxide TS.

Mobile phase B: Acetonitrile.

Flowing of mobile phase: Control the gradient by mixing the mobile phases A and B as directed in the following table.

Time after injection of sample (min)	Mobile phase A (vol%)	Mobile phase B (vol%)
0 – 12.5	80 → 35	20 → 65
12.5 – 15.5	35	65

Flow rate: 2.0 mL per minute.

Time span of measurement: For 15.5 minutes after injection, beginning after the solvent peak.

System suitability—

Test for required detectability: Pipet 1 mL of the standard solution, and add a mixture of acetonitrile and the mobile phase A (4:1) to make exactly 20 mL. Confirm that the peak area of hydrocortisone butyrate obtained with 5 μ L of this solution is equivalent to 3.5 to 6.5% of that with 5 μ L of the standard solution.

System performance: When the procedure is run with 5 μ L of the standard solution under the above operating conditions, the number of theoretical plates and the symmetry factor of the peak of hydrocortisone butyrate are not less than 10,000 and not more than 1.5, respectively.

System repeatability: When the test is repeated 6 times with 5 μ L of the standard solution under the above operating conditions, the relative standard deviation of the peak area of hydrocortisone butyrate is not more than 2.0%.

Loss on drying <2.41> Not more than 1.0% (1 g, 105°C, 3 hours).

Residue on ignition <2.44> Not more than 0.1% (1 g).

Assay Weigh accurately about 50 mg of Hydrocortisone Butyrate, previously dried, and dissolve in ethanol (99.5) to make exactly 100 mL. Pipet 2 mL of this solution, and add

ethanol (99.5) to make exactly 50 mL. Determine the absorbance *A* of this solution at the wavelength of maximum absorption at about 241 nm as directed under Ultraviolet-visible Spectrophotometry <2.24>.

$$\text{Amount (mg) of hydrocortisone butyrate (C}_{25}\text{H}_{36}\text{O}_6) = A/375 \times 25,000$$

Containers and storage Containers—Tight containers.

Hydrocortisone Sodium Phosphate

ヒドロコルチゾンリン酸エステルナトリウム

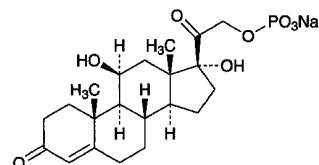

C₂₁H₂₉Na₂O₈P: 486.40

11 β ,17,21-Trihydroxypregn-4-ene-3,20-dione

21-(disodium phosphate)

[6000-74-4]

Hydrocortisone Sodium Phosphate contains not less than 96.0% and not more than 102.0% of hydrocortisone sodium phosphate (C₂₁H₂₉Na₂O₈P), calculated on the anhydrous basis.

Description Hydrocortisone Sodium Phosphate occurs as a white to light yellow powder.

It is freely soluble in water, sparingly soluble in methanol, and very slightly soluble in ethanol (95).

It is hygroscopic.

It shows crystal polymorphism.

Identification (1) To 2 mg of Hydrocortisone Sodium Phosphate add 2 mL of sulfuric acid: a yellowish green fluorescence is exhibited initially, then gradually changes through orange-yellow to dark red. Examine the solution under ultraviolet light (main wavelength: 254 nm): an intense, light green fluorescence is exhibited. To this solution add carefully 10 mL of water: the color changes from yellow to orange-yellow with a light green fluorescence and a yellow-brown, flocculent floating substance is formed.

(2) Determine the infrared absorption spectrum of Hydrocortisone Sodium Phosphate as directed in the paste method under Infrared Spectrophotometry <2.25>, and compare the spectrum with the Reference Spectrum or the spectrum of Hydrocortisone Sodium Phosphate RS: both spectra exhibit similar intensities of absorption at the same wave numbers. If any difference appears between the spectra, dissolve Hydrocortisone Sodium Phosphate and Hydrocortisone Sodium Phosphate RS in methanol, respectively, then evaporate the methanol to dryness, and repeat the test on the residues.

(3) Moisten 1.0 g of Hydrocortisone Sodium Phosphate with a small quantity of sulfuric acid, and incinerate by gradual heating. After cooling, dissolve the residue in 10 mL of dilute nitric acid, and heat in a water bath for 30 minutes. After cooling, filter if necessary. This solution responds to Qualitative Tests <1.09> for sodium salt and for phosphate.

Optical rotation <2.49> $[\alpha]_D^{20}$: +123 – +131° (1 g calculated on the anhydrous basis, phosphate buffer solution (pH 7.0), 100 mL, 100 mm).

pH <2.54> Dissolve 1.0 g of Hydrocortisone Sodium Phosphate in 100 mL of water: the pH of this solution is between 7.5 and 9.5.

Purity (1) Clarity and color of solution—Dissolve 1.0 g of Hydrocortisone Sodium Phosphate in 10 mL of water: the solution is clear and colorless to pale yellow.

(2) Chloride <1.03>—Dissolve 0.30 g of Hydrocortisone Sodium Phosphate in 20 mL of water, and add 6 mL of dilute nitric acid and water to make 100 mL. To 5 mL of this solution add water to make 50 mL. Perform the test using this solution as the test solution. Prepare the control solution with 0.25 mL of 0.01 mol/L hydrochloric acid VS (not more than 0.600%).

(3) Heavy metals <1.07>—Proceed with 0.5 g of Hydrocortisone Sodium Phosphate according to Method 2, and perform the test. Prepare the control solution with 2.0 mL of Standard Lead Solution (not more than 40 ppm).

(4) Arsenic <1.11>—Prepare the test solution with 1.0 g of Hydrocortisone Sodium Phosphate according to Method 3, and perform the test (not more than 2 ppm).

(5) Free phosphoric acid—Weigh accurately about 0.25 g of Hydrocortisone Sodium Phosphate, dissolve in water to make exactly 100 mL, and use this solution as the sample solution. Pipet 5 mL each of the sample solution and Standard Phosphoric Acid Solution into separate 25-mL volumetric flasks, add 2.5 mL of hexaammonium heptamolybdate-sulfuric acid TS and 1 mL of 1-amino-2-naphthol-4-sulfonic acid TS, shake, add water to make exactly 25 mL, and allow to stand at $20 \pm 1^\circ\text{C}$ for 30 minutes. Perform the test with these solutions as directed under Ultraviolet-visible Spectrophotometry <2.24>, using a solution prepared with 5 mL of water in the same manner as the blank. Determine the absorbances, A_T and A_S , at 740 nm of the sample solution and Standard Phosphoric Acid Solution: the amount of free phosphoric acid is not more than 1.0%.

$$\begin{aligned} \text{Content (\%)} \text{ of free phosphoric acid (H}_3\text{PO}_4) \\ = 1/M \times A_T/A_S \times 258.0 \end{aligned}$$

M : Amount (mg) of Hydrocortisone Sodium Phosphate taken, calculated on the anhydrous basis

(6) Free hydrocortisone—Dissolve 25 mg of Hydrocortisone Sodium Phosphate in the mobile phase to make exactly 20 mL, and use this solution as the sample solution. Separately, weigh 25 mg of Hydrocortisone RS, previously dried at 105°C for 3 hours, and dissolve in the mobile phase to make exactly 100 mL. Pipet 10 mL of this solution, add the mobile phase to make exactly 200 mL, and use this solution as the standard solution. Perform the test with exactly 20 μL each of the sample solution and standard solution as directed under Liquid Chromatography <2.01> according to the following conditions. Determine the peak areas, A_T and A_S , of hydrocortisone in each solution: A_T is not larger than A_S .

Operating conditions—

Proceed as directed in the operating conditions in the Assay.

System suitability—

System performance: Proceed as directed in the system suitability in the Assay.

System repeatability: When the test is repeated 6 times with 20 μL of the standard solution under the above operating conditions, the relative standard deviation of the peak area of hydrocortisone is not more than 1.0%.

Water <2.48> Not more than 5.0% (30 mg, coulometric titration).

Assay Weigh accurately about 20 mg each of Hydrocorti-

one Sodium Phosphate and Hydrocortisone Sodium Phosphate RS (previously determine the water <2.48> in the same manner as Hydrocortisone Sodium Phosphate), dissolve each in 50 mL of the mobile phase, add exactly 10 mL of the internal standard solution, then add the mobile phase to make 200 mL, and use these solutions as the sample solution and the standard solution, respectively. Perform the test with 20 μL each of the sample solution and standard solution as directed under Liquid Chromatography <2.01> according to the following conditions, and calculate the ratios, Q_T and Q_S , of the peak area of hydrocortisone phosphate to that of the internal standard, respectively.

$$\begin{aligned} \text{Amount (mg) of hydrocortisone sodium phosphate} \\ (\text{C}_{21}\text{H}_{29}\text{Na}_2\text{O}_8\text{P}) \\ = M_S \times Q_T/Q_S \end{aligned}$$

M_S : Amount (mg) of Hydrocortisone Sodium Phosphate RS taken, calculated on the anhydrous basis

Internal standard solution—A solution of isopropyl parahydroxybenzoate in the mobile phase (3 in 5000).

Operating conditions—

Detector: An ultraviolet absorption photometer (wavelength: 254 nm).

Column: A stainless steel column 4.6 mm in inside diameter and 25 cm in length, packed with octadecylsilanized silica gel for liquid chromatography (7 μm in particle diameter).

Column temperature: A constant temperature of about 25°C .

Mobile phase: A mixture of 0.05 mol/L sodium dihydrogen phosphate TS (pH 2.6) and methanol (1:1).

Flow rate: Adjust so that the retention time of hydrocortisone phosphate is about 10 minutes.

System suitability—

System performance: When the procedure is run with 20 μL of the standard solution under the above operating conditions, hydrocortisone phosphate and the internal standard are eluted in this order with the resolution between these peaks being not less than 8.

System repeatability: When the test is repeated 6 times with 20 μL of the standard solution under the above operating conditions, the relative standard deviation of the ratios of the peak area of hydrocortisone phosphate to that of the internal standard is not more than 1.0%.

Containers and storage Containers—Tight containers.

Hydrocortisone Sodium Succinate

ヒドロコルチゾンコハク酸エステルナトリウム

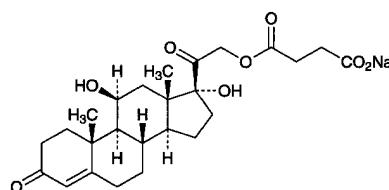

$\text{C}_{25}\text{H}_{33}\text{NaO}_8$: 484.51

Monosodium 11 β ,17,21-trihydroxypregn-4-ene-3,20-dione 21-succinate

[125-04-2]

Hydrocortisone Sodium Succinate, calculated on the dried basis, contains not less than 97.0% and not more than 103.0% of hydrocortisone sodium succinate ($\text{C}_{25}\text{H}_{33}\text{NaO}_8$).

Description Hydrocortisone Sodium Succinate occurs as a white, powder or masses.

It is freely soluble in water, in methanol and in ethanol (95).

It is hygroscopic.

It is gradually colored by light.

It shows crystal polymorphism.

Identification (1) Dissolve 0.2 g of Hydrocortisone Sodium Succinate in 20 mL of water, and add 0.5 mL of dilute hydrochloric acid with stirring: a white precipitate is formed. Collect the precipitate, wash it with two 10-mL portions of water, and dry at 105°C for 3 hours. To 3 mg of this dried matter add 2 mL of sulfuric acid: the solution shows a yellowish green fluorescence immediately, and the color of the solution gradually changes through orange-yellow to dark red. This solution shows a strong light green fluorescence under ultraviolet light. Add carefully 10 mL of water to this solution: the color changes from yellow to orange-yellow with a light green fluorescence, and a yellow-brown flocculent precipitate is formed.

(2) Dissolve 10 mg of the dried matter obtained in (1) in 1 mL of methanol, add 1 mL of Fehling's TS, and heat: an orange to red precipitate is formed.

(3) To 0.1 g of the dried matter obtained in (1) add 2 mL of sodium hydroxide TS, and allow to stand for 10 minutes. Filter the solution to remove the precipitate formed, mix the filtrate with 1 mL of dilute hydrochloric acid, filter if necessary, then adjust the solution to a pH of about 6 with diluted ammonia TS (1 in 10), and add 2 to 3 drops of iron (III) chloride TS: a brown precipitate is formed.

(4) Determine the infrared absorption spectrum of the dried matter obtained in (1) as directed in the potassium bromide disk method under Infrared Spectrophotometry <2.25>, and compare the spectrum with the Reference Spectrum or the spectrum of previously dried Hydrocortisone Succinate RS: both spectra exhibit similar intensities of absorption at the same wave numbers. If any difference appears between the spectra, dissolve Hydrocortisone Sodium Succinate and Hydrocortisone Succinate RS in methanol, respectively, then evaporate the methanol to dryness, and repeat the test on the residues.

(5) Hydrocortisone Sodium Succinate responds to Qualitative Tests <1.09> (1) for sodium salt.

Optical rotation <2.49> $[\alpha]_D^{20}$: +135 – +145° (0.1 g calculated on the dried basis, ethanol (95), 10 mL, 100 mm).

Purity (1) Clarity and color of solution—Dissolve 0.5 g of Hydrocortisone Sodium Succinate in 5 mL of water: the solution is clear and colorless.

(2) Related substances—Dissolve 25 mg of Hydrocortisone Sodium Succinate in methanol to make exactly 10 mL, and use this solution as the sample solution. Separately, dissolve 25 mg of hydrocortisone in methanol to make exactly 10 mL. Pipet 1 mL of this solution, add methanol to make exactly 20 mL, and use this solution as the standard solution (1). Pipet 6 mL of the standard solution (1), add methanol to make exactly 10 mL, and use this solution as the standard solution (2). Perform the test with these solutions as directed under Thin-layer Chromatography <2.03>. Spot 3 μ L each of the sample solution and standard solutions (1) and (2) on a plate of silica gel with fluorescent indicator for thin-layer chromatography. Develop the plate with a mixture of chloroform, ethanol (99.5) and formic acid (150:10:1) to a distance of about 10 cm, and air-dry the plate. Examine under ultraviolet light (main wavelength: 254 nm): the spot obtained from the sample solution corresponding to the spot

from the standard solution (1) is not more intense than the spot from the standard solution (1). Any spot other than the principal spot and the above spot from the sample solution is not more than one, and is not more intense than the spot from the standard solution (2).

Loss on drying <2.41> Not more than 2.0% (0.5 g, 105°C, 3 hours).

Assay Weigh accurately about 10 mg of Hydrocortisone Sodium Succinate, and dissolve in methanol to make exactly 100 mL. Pipet 5 mL of this solution, add methanol to make exactly 50 mL, and use this solution as the sample solution. Separately, weigh accurately about 10 mg of Hydrocortisone Succinate RS, previously dried at 105°C for 3 hours, proceed in the same manner as directed for the sample solution, and use this solution as the standard solution. Determine the absorbances, A_T and A_S , of the sample solution and standard solution at 240 nm as directed under Ultraviolet-visible Spectrophotometry <2.24>.

$$\begin{aligned} &\text{Amount (mg) of hydrocortisone sodium succinate} \\ &(\text{C}_{25}\text{H}_{33}\text{NaO}_8) \\ &= M_S \times A_T / A_S \times 1.048 \end{aligned}$$

M_S : Amount (mg) of Hydrocortisone Succinate RS taken

Containers and storage Containers—Tight containers.

Storage—Light-resistant.

Hydrocortisone Succinate

ヒドロコルチゾンコハク酸エステル

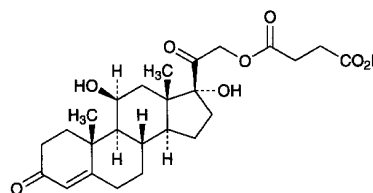

$\text{C}_{25}\text{H}_{34}\text{O}_8$: 462.53

11 β ,17,21-Trihydroxypregn-4-ene-3,20-dione
21-(hydrogen succinate)

[2203-97-6]

Hydrocortisone Succinate, when dried, contains not less than 97.0% and not more than 103.0% of hydrocortisone succinate ($\text{C}_{25}\text{H}_{34}\text{O}_8$).

Description Hydrocortisone Succinate occurs as a white crystalline powder.

It is very soluble in methanol, freely soluble in ethanol (99.5), and practically insoluble in water.

It shows crystal polymorphism.

Identification (1) To 3 mg of Hydrocortisone Succinate add 2 mL of sulfuric acid: the solution shows a yellowish green fluorescence immediately, and the color of the solution gradually changes through orange-yellow to dark red. This solution shows a strong light green fluorescence under ultraviolet light. Add carefully 10 mL of water to this solution: the color changes from yellow to orange-yellow with a light green fluorescence, and a yellow-brown flocculent precipitate is formed.

(2) Determine the infrared absorption spectrum of Hydrocortisone Succinate, previously dried, as directed in the potassium bromide disk method under Infrared Spectrophotometry <2.25>, and compare the spectrum with the Refer-

ence Spectrum or the spectrum of previously dried Hydrocortisone Succinate RS: both spectra exhibit similar intensities of absorption at the same wave numbers. If any difference appears between the spectra, dissolve Hydrocortisone Succinate and Hydrocortisone Succinate RS in methanol, respectively, then evaporate the methanol to dryness, and repeat the test on the residues.

Optical rotation <2.49> $[\alpha]_D^{20}$: +147 – +153° (after drying, 0.1 g, ethanol (99.5), 10 mL, 100 nm).

Purity Related substances—Dissolve 25 mg of Hydrocortisone Succinate in exactly 10 mL of methanol, and use this solution as the sample solution. Separately, dissolve 25 mg of hydrocortisone in exactly 10 mL of methanol. Pipet 1 mL of this solution, dilute with methanol to exactly 50 mL, and use this solution as the standard solution. Perform the test with these solutions as directed under Thin-layer Chromatography <2.03>. Spot 3 μ L each of the sample solution and standard solution on a plate of silica gel with fluorescent indicator for thin-layer chromatography. Develop the plate with a mixture of chloroform, ethanol (99.5) and formic acid (150:10:1) to a distance of about 10 cm, and air-dry the plate. Examine under ultraviolet light (main wavelength: 254 nm): the spots other than the principal spot obtained from the sample solution are not more intense than the spot from the standard solution.

Loss on drying <2.41> Not more than 2.0% (0.5 g, 105°C, 3 hours).

Residue on ignition <2.44> Not more than 0.1% (0.5 g).

Assay Weigh accurately about 50 mg each of Hydrocortisone Succinate and Hydrocortisone Succinate RS, previously dried, and dissolve in methanol to make exactly 50 mL. Pipet 5 mL each of these solutions, add exactly 5 mL each of the internal standard solution, then add methanol to make 50 mL, and use these solutions as the sample solution and standard solution. Perform the test with 10 μ L each of the sample solution and standard solution as directed under Liquid Chromatography <2.01> according to the following operating conditions, and calculate the ratios, Q_T and Q_S , of the peak area of hydrocortisone succinate to that of the internal standard, respectively.

$$\text{Amount (mg) of hydrocortisone succinate (C}_{25}\text{H}_{34}\text{O}_8) \\ = M_S \times Q_T / Q_S$$

M_S : Amount (mg) of Hydrocortisone Succinate RS taken

Internal standard solution—A solution of butyl parahydroxy benzoate in methanol (1 in 2500).

Operating conditions—

Detector: An ultraviolet absorption photometer (wavelength: 254 nm).

Column: A stainless steel column 4 mm in inside diameter and 30 cm in length, packed with octadecylsilanized silica gel (10 μ m in particle diameter).

Column temperature: A constant temperature of about 25°C.

Mobile phase: A mixture of acetic acid-sodium acetate buffer solution (pH 4.0) and acetonitrile (3:2).

Flow rate: Adjust so that the retention time of hydrocortisone succinate is about 5 minutes.

System suitability—

System performance: When the procedure is run with 10 μ L of the standard solution under the above operating conditions, hydrocortisone succinate and the internal standard are eluted in this order with the resolution between these peaks being not less than 9.

System repeatability: When the test is repeated 6 times with 10 μ L of the standard solution under the above operating conditions, the relative standard deviation of the ratios of the peak area of hydrocortisone succinate to that of the internal standard is not more than 1.0%.

Containers and storage Containers—Tight containers.

Storage—Light-resistant.

Hydrocotarnine Hydrochloride Hydrate

ヒドロコタルニン塩酸塩水和物

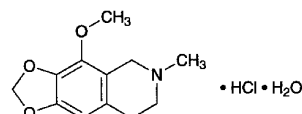

$\text{C}_{12}\text{H}_{15}\text{NO}_3 \cdot \text{HCl} \cdot \text{H}_2\text{O}$: 275.73
4-Methoxy-6-methyl-5,6,7,8-tetrahydro[1,3]dioxolo[4,5-g]isoquinoline monohydrochloride monohydrate
[5985-55-7, anhydride]

Hydrocotarnine Hydrochloride Hydrate, when dried, contains not less than 98.0% of hydrocotarnine-hydrochloride ($\text{C}_{12}\text{H}_{15}\text{NO}_3 \cdot \text{HCl}$: 257.72).

Description Hydrocotarnine Hydrochloride Hydrate occurs as white to pale yellow, crystals or crystalline powder.

It is freely soluble in water, sparingly soluble in ethanol (95) and in acetic acid (100), and slightly soluble in acetic anhydride.

Identification (1) Determine the absorption spectrum of a solution of Hydrocotarnine Hydrochloride Hydrate (1 in 10,000) as directed under Ultraviolet-visible Spectrophotometry <2.24>, and compare the spectrum with the Reference Spectrum: both spectra exhibit similar intensities of absorption at the same wavelengths.

(2) Determine the infrared absorption spectrum of Hydrocotarnine Hydrochloride Hydrate as directed in the potassium bromide disk method under Infrared Spectrophotometry <2.25>, and compare the spectrum with the Reference Spectrum: both spectra exhibit similar intensities of absorption at the same wave numbers.

(3) A solution of Hydrocotarnine Hydrochloride Hydrate (1 in 50) responds to Qualitative Tests <1.09> (2) for chloride.

pH <2.54> Dissolve 1.0 g of Hydrocotarnine Hydrochloride Hydrate in 20 mL of water: the pH of the solution is between 4.0 and 6.0.

Purity (1) Clarity and color of solution—Dissolve 0.5 g of Hydrocotarnine Hydrochloride Hydrate in 10 mL of water: the solution is clear, and when perform the test with this solution as directed under Ultraviolet-visible Spectrophotometry <2.24>, using water as the blank, the absorbance at 400 nm is not more than 0.17.

(2) Heavy metals <1.07>—Proceeds with 1.0 g of Hydrocotarnine Hydrochloride Hydrate according to Method 1, and perform the test. Prepare the control solution with 2.0 mL of Standard Lead Solution (not more than 20 ppm).

(3) Related substances—Dissolve 0.10 g of Hydrocotarnine Hydrochloride Hydrate in 10 mL of diluted ethanol

(99.5) (1 in 2), and use this solution as the sample solution. Pipet 1 mL of the sample solution, add diluted ethanol (99.5) (1 in 2) to make exactly 100 mL, and use this solution as the standard solution. Perform the test with these solutions as directed under Thin-layer Chromatography <2.03>. Spot 10 μL each of the sample solution and standard solution on a plate of silica gel with fluorescent indicator for thin-layer chromatography. Develop the plate with a mixture of acetone, toluene, ethanol (99.5) and ammonia water (28) (20:20:3:1) to a distance of about 15 cm, and air-dry the plate. Examine under ultraviolet light (main wavelength: 365 nm): the spots other than the principal spot obtained from the sample solution are not more intense than the spot from the standard solution.

Loss on drying <2.41> Not more than 7.0% (1 g, 105°C, 3 hours).

Residue on ignition <2.44> Not more than 0.2% (1 g).

Assay Weigh accurately about 0.5 g of Hydrocotarnine Hydrochloride Hydrate, previously dried. Dissolve in 50 mL of a mixture of acetic anhydride and acetic acid (100) (7:3) by warming. Cool, and titrate <2.50> with 0.1 mol/L perchloric acid VS (potentiometric titration). Perform a blank determination in the same manner, and make any necessary correction.

Each mL of 0.1 mol/L perchloric acid VS
= 25.77 mg of $\text{C}_{12}\text{H}_{15}\text{NO}_3 \cdot \text{HCl}$

Containers and storage Containers—Tight containers.

Hydrogenated Oil

硬化油

Hydrogenated Oil is the fat obtained by hydrogenation of fish oil or of other oils originating from animal or vegetable.

Description Hydrogenated Oil occurs as a white mass or powder and has a characteristic odor and a mild taste.

It is freely soluble in diethyl ether, very slightly soluble in ethanol (95), and practically insoluble in water.

The oil obtained by hydrogenation of castor oil is slightly soluble in diethyl ether, very slightly soluble in ethanol (95), and practically insoluble in water.

Acid value <1.13> Not more than 2.0.

Purity (1) Moisture and coloration—Hydrogenated Oil (5.0 g), melted by heating on a water bath, forms a clear liquid, from which no water separates. In a 10-mm thick layer of the liquid, it is colorless or slightly yellow.

(2) Alkalinity—To 2.0 g of Hydrogenated Oil add 10 mL of water, melt by heating on a water bath, and shake vigorously. After cooling, add 1 drop of phenolphthalein TS to the separated water layer: no color develops.

(3) Chloride—To 1.5 g of Hydrogenated Oil add 30 mL of ethanol (95), boil for 10 minutes under a reflux condenser, and filter after cooling. To 20 mL of the filtrate add 5 drops of a solution of silver nitrate in ethanol (95) (1 in 50): the turbidity of the solution does not exceed that of the following control solution.

Control solution: To 1.0 mL of 0.01 mol/L hydrochloric acid VS add ethanol (95) to make 20 mL, then add 5 drops of a solution of silver nitrate in ethanol (95) (1 in 50).

(4) Heavy metals—Heat 2.0 g of Hydrogenated Oil with

5 mL of dilute hydrochloric acid and 10 mL of water on a water bath for 5 minutes with occasional shaking. After cooling, filter, and make 5 mL of the filtrate weakly alkaline with ammonia TS, then add 3 drops of sodium sulfide TS: the solution remains unchanged.

(5) Nickel—Place 5.0 g of Hydrogenated Oil in a quartz or porcelain crucible, heat slightly with caution at the beginning, and, after carbonization, incinerate by strong heating ($500 \pm 20^\circ\text{C}$). Cool, add 1 mL of hydrochloric acid, evaporate on a water bath to dryness, dissolve the residue in 3 mL of dilute hydrochloric acid, and add 7 mL of water. Then add 1 mL of bromine TS and 1 mL of a solution of citric acid monohydrate (1 in 5), make alkaline with 5 mL of ammonia TS, and cool in running water. To this solution add 1 mL of dimethylglyoxime TS, add water to make 20 mL, and use this solution as the test solution. Allow to stand for 5 minutes: the solution has no more color than the following control solution.

Control solution: Evaporate 1 mL of hydrochloric acid on a water bath to dryness, add 1 mL of Standard Nickel Solution and 3 mL of dilute hydrochloric acid, and add 6 mL of water. Then proceed as directed in the test solution, add water to make 20 mL, and allow to stand for 5 minutes.

Residue on ignition <2.44> Not more than 0.1% (5 g).

Containers and storage Containers—Well-closed containers.

Hydroxocobalamin Acetate

ヒドロキソコバラミン酢酸塩

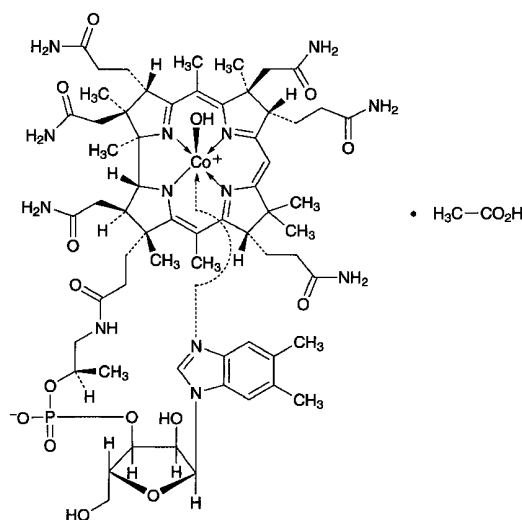

$\text{C}_{62}\text{H}_{89}\text{CoN}_{13}\text{O}_{15}\text{P} \cdot \text{C}_2\text{H}_4\text{O}_2$: 1406.41
Co α -[α -(5,6-Dimethyl-1*H*-benzimidazol-1-yl)]-*Co* β -hydroxocobamide monoacetate
[13422-51-0, Hydroxocobalamin]

Hydroxocobalamin Acetate contains not less than 96.0% and not more than 101.0% of hydroxocobalamin acetate ($\text{C}_{62}\text{H}_{89}\text{CoN}_{13}\text{O}_{15}\text{P} \cdot \text{C}_2\text{H}_4\text{O}_2$), calculated on the anhydrous and residual solvent-free basis.

Description Hydroxocobalamin Acetate occurs as dark red, crystals or powder. It is odorless.

It is freely soluble in water and in methanol, slightly soluble in ethanol (95), and practically insoluble in diethyl ether.

It is hygroscopic.

Identification (1) Determine the absorption spectrum of a solution of Hydroxocobalamin Acetate in acetic acid-sodium acetate buffer solution (pH 4.5) (1 in 50,000) as directed under Ultraviolet-visible Spectrophotometry <2.24>, and compare the spectrum with the Reference Spectrum: both spectra exhibit similar intensities of absorption at the same wavelengths.

(2) Mix 1 mg of Hydroxocobalamin Acetate with 50 mg of potassium hydrogen sulfate, and fuse by igniting. Cool, break up the mass with a glass rod, add 3 mL of water, and dissolve by boiling. Add 1 drop of phenolphthalein TS, and add dropwise sodium hydroxide TS until the solution develops a light red. Then add 0.5 g of sodium acetate trihydrate, 0.5 mL of dilute acetic acid and 0.5 mL of a solution of disodium 1-nitroso-2-naphthol-3,6-disulfonate (1 in 500): a red to orange-red color develops immediately. Then add 0.5 mL of hydrochloric acid, and boil for 1 minute: the red color does not disappear.

(3) Add 0.5 mL of ethanol (99.5) and 1 mL of sulfuric acid to 20 mg of Hydroxocobalamin Acetate, and heat the mixture: the odor of ethyl acetate is perceptible.

Purity Conduct this procedure using light-resistant vessels. Dissolve 75 mg of Hydroxocobalamin Acetate in 100 mL of the dissolving solution, and use this solution as the sample solution. Pipet 1 mL of the sample solution, add the dissolving solution to make exactly 20 mL, and use this solution as the standard solution. Perform the test with exactly 20 μ L each of the sample solution and standard solution as directed under Liquid Chromatography <2.01> according to the following conditions, and determine each peak area by the automatic integration method: the total area of the peaks other than hydroxocobalamin obtained from the sample solution is not larger than the peak area of hydroxocobalamin from the standard solution.

Dissolving solution: A mixture of water, mobile phase C and methanol (41:5:4).

Operating conditions—

Detector: An ultraviolet absorption photometer (wavelength: 351 nm).

Column: Connect two columns which are 4.6 mm in inside diameter and 10 cm in length, composed of octadecylsilanized monolithic silica for liquid chromatography, having a bimodal pore structure with 2 μ m macropore and 13 nm mesopore, coated with polyether ether ketone.

Column temperature: A constant temperature of about 30°C.

Mobile phase A: Water.

Mobile phase B: Methanol.

Mobile phase C: Dissolve 15.6 g of sodium dihydrogen phosphate dihydrate in 1000 mL of water, and adjust to pH 3 with diluted phosphoric acid (1 in 100).

Flowing of mobile phase: Control the gradient by mixing the mobile phase A, B and C as directed in the following table.

Time after injection of sample (min)	Mobile phase A (vol%)	Mobile phase B (vol%)	Mobile phase C (vol%)
0 – 20	82	8	10
20 – 40	82 → 50	8 → 40	10

Flow rate: 2 mL per minute.

Time span of measurement: For 40 minutes after injection of the sample solution.

System suitability—

Test for required detectability: Pipet 1 mL of the standard solution, add the dissolving solution to make exactly 50 mL. Confirm that the peak area of hydroxocobalamin obtained with 20 μ L of this solution is equivalent to 1.4 to 2.6% of that with 20 μ L of the standard solution.

System performance: When the procedure is run with 20 μ L of the standard solution under the above operating conditions, the number of theoretical plates and the symmetry factor of the peak of hydroxocobalamin are not less than 4000 and not more than 2.4, respectively.

System repeatability: When the test is repeated 6 times with 20 μ L of the standard solution under the above operating conditions, the relative standard deviation of the peak area of hydroxocobalamin is not more than 2.0%.

Water <2.48> 8.0 – 12.0% (50 mg, volumetric titration, direct titration).

Assay Weigh accurately about 0.1 g of Hydroxocobalamin Acetate, and dissolve in water to make exactly 500 mL. Pipet 5 mL of this solution, and add acetic acid-sodium acetate buffer solution (pH 4.5) to make exactly 25 mL. Determine the absorbance, *A*, of this solution at 351 nm as directed under Ultraviolet-visible Spectrophotometry <2.24>.

$$\begin{aligned} &\text{Amount (mg) of hydroxocobalamin acetate} \\ &(\text{C}_{62}\text{H}_{89}\text{CoN}_{13}\text{O}_{15}\text{P}\cdot\text{C}_2\text{H}_4\text{O}_2) \\ &= A/187 \times 25,000 \end{aligned}$$

Containers and storage Containers—Tight containers.

Storage—Light-resistant, and in a cold place.

Hydroxyethylcellulose

ヒドロキシエチルセルロース

[9004-62-0]

This monograph is harmonized with the European Pharmacopoeia and the U. S. Pharmacopoeia.

The corresponding part of the attributes/provisions which are agreed as non-harmonized within the scope of the harmonization is marked with symbols (◆ ◆), and the corresponding parts which are agreed as the JP local requirement other than the scope of the harmonization are marked with symbols (◇ ◇).

Information on the harmonization with the European Pharmacopoeia and the U.S. Pharmacopoeia is available on the website of the Pharmaceuticals and Medical Devices Agency.

Hydroxyethylcellulose is partly *O*-(2-hydroxyethylated) cellulose.

It contains not less than 30.0% and not more than 70.0% of hydroxyethoxy group (-OC₂H₄OH: 61.06), calculated on the dried basis.

It may contain suitable pH-adjusting agents such as phosphates.

◆The viscosity is shown in millipascal second (mPa·s) on the label.◆

◆**Description** Hydroxyethylcellulose occurs as a white to yellowish white, powder or grains.

It is practically insoluble in ethanol (95).

It forms a viscous liquid upon addition of water.

It is hygroscopic.◆

Identification (1) Determine the infrared absorption spec-

trum of Hydroxyethylcellulose as directed in the ATR method under Infrared Spectrophotometry <2.25> and compare the spectrum with the spectrum of Hydroxyethylcellulose for Identification RS: both spectra exhibit similar intensities of absorption at the same wave numbers.

(2) Disperse 1.0 g of Hydroxyethylcellulose, calculated on the dried basis, in 50 mL of freshly boiled and cooled water. After 10 minutes, add freshly boiled and cooled water to make 100 mL, stir to dissolve completely, and use this solution as the sample solution. Boil 10 mL of the sample solution: the solution is clear.

◆**Viscosity** <2.53> Weigh exactly a quantity of Hydroxyethylcellulose, equivalent to 10.00 g calculated on the dried basis, add 400 mL of water, stir to dissolve, and add water to make exactly 500.0 g. Remove air bubbles, and use this solution as the sample solution. Perform the test with the sample solution at $20 \pm 0.1^\circ\text{C}$ as directed in Method II under Viscosity Determination, using a beaker with an inside diameter of not less than 70 mm and a single cylinder-type rotational viscometer, according to the following operating conditions: not less than 75% and not more than 140% of the labeled viscosity.

Operating conditions—

Apparatus: Brookfield type viscometer LV or RV model.

Rotor No., rotation frequency and calculation multiplier: According to the following table, depending on the labeled viscosity.

Labeled viscosity (mPa·s)	Model	Rotor No.	Rotation frequency /min	Calculation multiplier
less than 200	LV	1	30	2
Not less than 200 and less than 4000	LV	3	30	40
" 4000 " 10,000	LV	4	30	200
" 10,000 " 50,000	RV	6	20	500
" 50,000	RV	7	20	2000

Procedure of apparatus: Read a value after 2 minutes of rotation, and stop the rotation for at least 2 minutes. Repeat this procedure more two times, and average the three observed values.◆

pH <2.54> The pH of the sample solution obtained in the Identification (2) is between 5.5 and 8.5.

Purity (1) Chloride—To 1 mL of the sample solution obtained in the Identification (2) add water to make 30 mL, and use this solution as the sample solution. Separately, to 10 mL of Standard Chloride Solution add 5 mL of water, and use this solution as the control solution. To 15 mL each of the sample solution and control solution add 1 mL of diluted nitric acid (1 in 5), transfer to test tubes containing 1 mL of a solution of silver nitrate (17 in 1000), allow to stand for 5 minutes protecting from light, and compare the opalescence developed in the both solutions against a black background by viewing transversely: the opalescence developed in the sample solution is not more intense than that of the control solution (not more than 1.0%).

(2) Nitrate—Prepare the solutions before use. Dissolve 0.50 g of Hydroxyethylcellulose in the diluting solution to make exactly 100 mL, and use this solution as the sample solution. Separately, dissolve 0.8154 g of potassium nitrate in the diluting solution to make 1000 mL, and use this solution as the standard nitrate stock solution. If the viscosity of Hydroxyethylcellulose is not more than 1000 mPa·s, pipet 10 mL, 20 mL and 40 mL of the standard nitrate stock solution, add the diluting solution to each to make exactly

100 mL, and use these solutions as the standard solutions. If the viscosity of Hydroxyethylcellulose is more than 1000 mPa·s, pipet 1 mL, 2 mL and 4 mL of the standard nitrate stock solution, add the diluting solution to each to make exactly 100 mL, and use these solutions as the standard solutions. Perform the test with the sample solution and standard solutions using a nitrate-selective electrode as an indicator electrode, a silver-silver chloride electrode as a reference electrode and diluted ammonium sulfate TS (1 in 30) as reference electrolyte. Calculate the concentration of nitrates in the sample solution using a calibration curve obtained from the potential differences of the standard solutions: not more than 3.0%, calculated on the dried basis, if Hydroxyethylcellulose has a viscosity of not more than 1000 mPa·s, and not more than 0.2%, calculated on the dried basis, if Hydroxyethylcellulose has a viscosity of more than 1000 mPa·s.

Diluting solution: To a mixture of 50 mL of 1 mol/L sulfuric acid TS and 800 mL of water add 135 g of potassium dihydrogen phosphate, and add water to make 1000 mL. To this solution add water to make exactly 25 times the initial volume.

In order to determine the applicable limit, determine the viscosity using the following procedure.

Introduce a quantity of Hydroxyethylcellulose, equivalent to 2.00 g calculated on the dried basis, into 50 g of water, stir, add water to make 100 g, and stir to dissolve completely. Determine the viscosity using a rotating viscometer at 25°C and at a shear rate of 100 s^{-1} for substances with an expected viscosity less than 100 mPa·s, at a shear rate of 10 s^{-1} for substances with an expected viscosity not less than 100 mPa·s and not more than 20,000 mPa·s, and at a shear rate of 1 s^{-1} for substances with an expected viscosity more than 20,000 mPa·s. If it is impossible to obtain a shear rate of exactly 10 s^{-1} or 100 s^{-1} respectively, use a rate slightly higher and a rate slightly lower and interpolate.

◇(3) Heavy metal <1.07>—Proceed with 1.0 g of Hydroxyethylcellulose according to Method 2, and perform the test. Prepare the control solution with 2.0 mL of Standard Lead Solution (not more than 20 ppm).◇

(4) Aldehydes—Introduce 1.0 g of Hydroxyethylcellulose into a glass-stoppered test tube, add 10 mL of ethanol (99.5), stopper the tube tightly, and stir for 30 minutes. Centrifuge, and use the supernatant liquid as the sample solution. Use Standard Glyoxal Solution as the control solution. Pipet 2 mL each of the sample solution and control solution, to each add 5 mL of a solution prepared by dissolving 4 g of 3-methyl-2-benzothiazolonehydrazone hydrochloride monohydrate in diluted acetic acid (100) (4 in 5) to make 1000 mL, shake to homogenize, and allow to stand for 2 hours. Compare the color of these solutions: the sample solution is not more intensely colored than the control solution (not more than 20 ppm).

Loss on drying <2.41> Not more than 10.0% (1 g, 105°C , 3 hours).

Residue on Ignition <2.44> Not more than 4.0% if the viscosity of Hydroxyethylcellulose is not more than 1000 mPa·s, and not more than 1.0% if the viscosity of Hydroxyethylcellulose is more than 1000 mPa·s (1 g). In order to determine the applicable limit, determine the viscosity according to the method in the Purity (2).

Assay Weigh accurately about 30 mg of Hydroxyethylcellulose, transfer to a 5-mL pressure-tight serum vial, add exactly 60 mg of adipic acid, 2 mL of the internal standard solution and 1 mL of hydroiodic acid, seal the vial immediately with a septum coated with fluororesin and an aluminum cap

or any other sealing system providing a sufficient air-tightness, and weigh accurately the vial. Take care not to mix the content of the vial before heating. Place the vial in an oven or heat in a suitable heater with continuous stirring, maintaining the internal temperature of about $165 \pm 2^\circ\text{C}$ for 2.5 hours. Allow to cool and weigh accurately the vial. If the difference of the mass between before heating and after heating is more than 10 mg, prepare a new sample solution. If the difference of the mass between before heating and after heating is not more than 10 mg, after phase separation, pierce through the septum of the vial with a cooled syringe, and withdraw a sufficient volume of the upper phase as the sample solution. Separately, place exactly 60 mg of adipic acid, 2 mL of the internal standard solution and 1 mL of hydroiodic acid in another serum vial, and seal immediately. Weigh accurately the vial, inject 55 μL of iodoethane for assay through the septum in the vial, and weigh again accurately. Shake thoroughly, after phase separation, pierce through the septum of the vial with a cooled syringe, and withdraw a sufficient volume of the upper phase as the standard solution. Perform the test with 1 μL each of the sample solution and standard solution as directed under Gas Chromatography <2.02> according to the following conditions, and calculate the ratios, Q_T and Q_S , of the peak area of iodoethane to that of the internal standard.

$$\begin{aligned} \text{Amount (\%)} & \text{ of hydroethoxy group (C}_2\text{H}_5\text{O}_2) \\ & = M_S/M_T \times Q_T/Q_S \times 39.15 \end{aligned}$$

M_S : Amount (mg) of iodoethane for assay taken

M_T : Amount (mg) of Hydroxyethylcellulose taken, calculated on the dried basis

Internal standard solution—A solution of *n*-octane in *o*-xylene (1 in 200).

Operating conditions—

Detector: A hydrogen flame-ionization detector.

Column: A fused silica column 0.53 mm in inside diameter and 30 m in length, coated with dimethylpolysiloxane for gas chromatography in 3 μm thickness.

Column temperature: Maintain the temperature at 50°C for 3 minutes, raise to 100°C at a rate of 10°C per minute, then raise to 250°C at a rate of 35°C per minute, and maintain at 250°C for 8 minutes.

Injection port temperature: A constant temperature of about 250°C .

Detector temperature: A constant temperature of about 280°C .

Carrier gas: Helium.

Flow rate: 4.2 mL per minutes (the retention time of the internal standard is about 10 minutes).

Split ratio: 1:40.

System suitability—

System performance: When the procedure is run with 1 μL of the standard solution under the above operating conditions, iodoethane and the internal standard are eluted in this order with the relative retention time of iodoethane to the internal standard being about 0.6 and the resolution between these peaks being not less than 5.0.

System repeatability: When the test is repeated 6 times with 1 μL of the standard solution under the above operating conditions, the relative standard deviation of the ratio of the peak area of iodoethane to that of the internal standard is not more than 2.0%.

◆**Containers and storage** Containers—Tight containers.◆

Hydroxypropylcellulose

ヒドロキシプロピルセルロース

[9004-64-2]

This monograph is harmonized with the European Pharmacopoeia and the U. S. Pharmacopoeia.

The corresponding part of the attributes/provisions which are agreed as non-harmonized within the scope of the harmonization is marked with symbols (◆ ◆), and the corresponding parts which are agreed as the JP local requirement other than the scope of the harmonization are marked with symbols (◇ ◇).

Information on the harmonization with the European Pharmacopoeia and the U.S. Pharmacopoeia is available on the website of the Pharmaceuticals and Medical Devices Agency.

Hydroxypropylcellulose is partially *O*-(2-hydroxypropylated) cellulose.

It contains not less than 53.4% and not more than 80.5% of hydroxypropoxy group ($-\text{OC}_3\text{H}_6\text{OH}$: 75.09), calculated on the dried basis.

It may contain silicon dioxide as anti-caking agent.

◆The label states the addition in the case where silicon dioxide is added as anti-caking agent.◆

◆**Description** Hydroxypropylcellulose occurs as a white to yellowish white powder.

It forms a viscous liquid upon addition of water or ethanol (95).◆

Identification (1) Dissolve 1 g of Hydroxypropylcellulose in 100 mL of water, transfer 1 mL of the solution to a glass plate, and allow the water to evaporate: a thin film is formed.

(2) Determine the infrared absorption spectrum of Hydroxypropylcellulose as directed in the potassium bromide disk method under Infrared Spectrophotometry <2.25>, and compare the spectrum with the Reference Spectrum: both spectra exhibit similar intensities of absorption at the same wave numbers. If there are an absorption at about 1719 cm^{-1} , disregard the absorption.

pH <2.54> Disperse evenly 1.0 g of Hydroxypropylcellulose in 100 mL of freshly boiled water, and allow to cool the mixture while stirring with a magnetic stirrer: the pH of the solution is between 5.0 and 8.0.

Purity

◇(1) Heavy metals<1.07>—Proceed with 1.0 g of Hydroxypropylcellulose according to Method 2 and perform the test. Prepare the control solution with 2.0 mL of Standard Lead Solution (not more than 20 ppm).◇

(2) Silicon dioxide—Apply to Hydroxypropylcellulose, if the addition of silicon dioxide is stated on the label and if more than 0.2% residue is found in the Residue on ignition test. Weigh accurately the crucible containing the residue tested in the Residue on ignition of Hydroxypropylcellulose (*a* (g)). Moisten the residue with water, and add 5 mL of hydrofluoric acid, in small portions. Evaporate it on a steam bath to dryness and cool. Add 5 mL of hydrofluoric acid and 0.5 mL of sulfuric acid, and evaporate to dryness. Slowly increase the temperature until all the acids have been volatilized, and ignite at $1000 \pm 25^\circ\text{C}$. Cool the crucible in a desiccator, and weigh (*b* (g)). Calculate the amount of silicon dioxide by the following equation: not more than 0.6%.

$$\begin{aligned} & \text{Amount (\%)} \text{ of silicon dioxide (SiO}_2\text{)} \\ & = (a - b)/M \times 100 \end{aligned}$$

M: Amount (g) of Hydroxypropylcellulose used for residue on ignition test

Loss on drying <2.41> Not more than 5.0% (1 g, 105°C, 4 hours).

Residue on ignition <2.44> Not more than 0.8% (1 g, platinum crucible).

Assay Weigh accurately about 30 mg of Hydroxypropylcellulose, transfer to a reaction vial, add exactly 60 mg of adipic acid, 2 mL of the internal standard solution and 1 mL of hydriodic acid, stopper the vial tightly, and weigh accurately. Place the vial in an oven or heat by a suitable heater with continuous stirring, maintaining the internal temperature of $115 \pm 2^\circ\text{C}$ for 70 minutes. Allow the vial to cool and weigh accurately. If the difference of the mass between before heating and after heating is more than 10 mg, prepare a new test solution. If the difference of the mass between before heating and after heating is not more than 10 mg, after phase separation by allowing the vial to stand, pierce through the septum of the vial with a cooled syringe, and withdraw a sufficient volume of the upper phase as the sample solution. Separately, place exactly 60 mg of adipic acid, 2 mL of internal standard solution and 1 mL of hydriodic acid in another reaction vial, stopper tightly, and weigh accurately. Inject 25 μL of isopropyl iodide for assay through the septum, and again weigh accurately. Shake the vial thoroughly, and after phase separation by allowing the vial to stand, pierce through the septum of the vial with a cooled syringe, and withdraw a sufficient volume of the upper phase as the standard solution. Perform the test with 2 μL each of the sample solution and standard solution as directed under Gas Chromatography <2.02> according to the following conditions, and calculate the ratios, Q_T and Q_S , of the peak area of isopropyl iodide to that of the internal standard.

$$\begin{aligned} & \text{Amount (\%)} \text{ of hydroxypropoxy group (C}_3\text{H}_7\text{O}_2\text{)} \\ & = M_S/M_T \times Q_T/Q_S \times 1.15 \times 44.17 \end{aligned}$$

M_S : Amount (mg) of isopropyl iodide for assay taken

M_T : Amount (mg) of Hydroxypropylcellulose taken, calculated on the dried basis

1.15: Correction factor

Internal standard solution—A solution of methylcyclohexan in *o*-xylene (1 in 50).

Operating conditions—

Detector: A hydrogen flame-ionization detector.

Column: A fused silica tube 0.53 mm in diameter and 30 m in length, coated with methylsilicone polymer for gas chromatography in 3 μm thickness.

Column Temperature: Maintain the temperature at 40°C for 3 minutes, raise to 100°C at a rate of 10°C per minute, then raise to 250°C at a rate of 50°C per minute, and maintain at 250°C for 3 minutes.

Injection port temperature: A constant temperature of about 180°C.

Detector temperature: A constant temperature of about 280°C.

Carrier gas: Helium.

Flow rate: 52 cm per second (the retention time of the internal standard is about 8 minutes).

Split ratio: 1:50.

System suitability—

System performance: When the procedure is run with 2 μL of the standard solution under the above operating condi-

tions, isopropyl iodide and the internal standard are eluted in this order with the relative retention time of isopropyl iodide to the internal standard being about 0.8, and with the resolution between these peaks being not less than 2.0.

System repeatability: When the test is repeated 6 times with 2 μL of the standard solution under the above operating conditions, the relative standard deviation of the ratio of the peak area of isopropyl iodide to that of the internal standard is not more than 2.0%.

◆**Containers and storage** Containers—Well-closed containers.◆

Low Substituted Hydroxypropylcellulose

低置換度ヒドロキシプロピルセルロース

[9004-64-2, Hydroxypropylcellulose]

This monograph is harmonized with the European Pharmacopoeia and the U.S. Pharmacopoeia.

The corresponding part of the attributes/provisions which are agreed as non-harmonized within the scope of the harmonization is marked with symbols (◆ ◆), and the corresponding parts which are agreed as the JP local requirement other than the scope of the harmonization are marked with symbols (◇ ◇).

Information on the harmonization with the European Pharmacopoeia and the U.S. Pharmacopoeia is available on the website of the Pharmaceuticals and Medical Devices Agency.

Low Substituted Hydroxypropylcellulose is a low substituted hydroxypropyl ether of cellulose.

It contains not less than 5.0% and not more than 16.0% of hydroxypropoxy group ($-\text{OC}_3\text{H}_6\text{OH}$: 75.09), calculated on the dried basis.

◆**Description** Low Substituted Hydroxypropylcellulose occurs as a white to yellowish white, powder or granules.

It is practically insoluble in ethanol (99.5).

It dissolves in a solution of sodium hydroxide (1 in 10), and produces a viscous solution.

It swells in water, in sodium carbonate TS and in 2 mol/L hydrochloric acid TS.◆

Identification

(1) Shake thoroughly 0.1 g of Low Substituted Hydroxypropylcellulose with 10 mL of water: it does not dissolve.

(2) To the dispersed solution obtained in (1) add 1 g of sodium hydroxide, and shake until the solution becomes uniform. Transfer 5 mL of this solution to a suitable vessel, add 10 mL of a mixture of acetone and methanol (4:1), and shake: a white, flocculent precipitate is formed.

(3) Determine the infrared absorption spectrum of Low Substituted Hydroxypropylcellulose as directed in the potassium bromide disk method under Infrared Spectrophotometry <2.25>, and compare the spectrum with the Reference Spectrum: both spectra exhibit similar intensities of absorption at the same wave numbers.

pH <2.54> To 1.0 g of Low Substituted Hydroxypropylcellulose add 100 mL of freshly boiled and cooled water, and shake: the pH of the solution is between 5.0 and 7.5.

Purity ◇Heavy metals <1.07>—Proceed with 2.0 g of Low Substituted Hydroxypropylcellulose according to Method 2,

and perform the test. Prepare the control solution with 2.0 mL of Standard Lead Solution (not more than 10 ppm).◇

Loss on drying <2.41> Not more than 5.0% (1 g, 105°C, 1 hour).

Residue on ignition <2.44> Not more than 0.8% (1 g).

Assay (i) Apparatus—Reaction vial: A 5-mL pressure-tight serum vial, 20 mm in outside diameter and 50 mm in height, 20 mm in outside diameter and 13 mm in inside diameter at the neck, equipped with a septum made of butyl-rubber whose surface is processed with fluoroplastics, which can be fixed to the vial and stoppered tightly with an aluminum cap or another system providing an equivalent airtightness.

Heater: A square-shaped aluminum block, having holes 20 mm in diameter and 32 mm in depth, adopted to the reaction vial. Capable of stirring the content of the reaction vial by means of a magnetic stirrer or of a reciprocal shaker about 100 times per minute.

(ii) Procedure—Weigh accurately about 65 mg of Low Substituted Hydroxypropylcellulose, transfer to a reaction vial, add 0.06 to 0.10 g of adipic acid, 2.0 mL of the internal standard solution and 2.0 mL of hydroiodic acid, immediately stopper the vial tightly, and weigh accurately. Using a magnetic stirrer equipped in the heating module, or using a shaker, mix for 60 minutes while heating so that the temperature of the vial content is $130 \pm 2^\circ\text{C}$. In the case when a magnetic stirrer or shaker is not available, heat for 30 minutes with repeated shaking at 5-minute intervals by hand, and continue heating for an additional 30 minutes. Allow the vial to cool, and again weigh accurately. If the mass loss is less than 26 mg and there is no evidence of a leak of the content, use the upper layer of the mixture as the sample solution. Separately, put 0.06 to 0.10 g of adipic acid, 2.0 mL of the internal standard solution and 2.0 mL of hydroiodic acid in a reaction vial, immediately stopper the vial tightly, and weigh accurately. Add 15 to 22 μL of isopropyl iodide for assay through the septum using a microsyringe, and weigh accurately. Shake the reaction vial thoroughly, and use the upper layer of the content as the standard solution. Perform the test with 1 to 2 μL each of the sample solution and standard solution as directed under Gas Chromatography <2.02> according to the following conditions, and calculate the ratios, Q_T and Q_S , of the peak area of isopropyl iodide to that of the internal standard.

$$\begin{aligned} \text{Amount (\%)} \text{ of hydroxypropoxy group (C}_3\text{H}_7\text{O}_2) \\ = M_S/M_T \times Q_T/Q_S \times 44.17 \end{aligned}$$

M_S : Amount (mg) of isopropyl iodide for assay taken

M_T : Amount (mg) of Low Substituted Hydroxypropylcellulose taken, calculated on the dried basis

Internal standard solution—A solution of *n*-octane in *o*-xylene (3 in 100).

Operating conditions—

Detector: A thermal conductivity detector or hydrogen flame-ionization detector.

Column: A fused silica column 0.53 mm in inside diameter and 30 m in length, coated with dimethylpolysiloxane for gas chromatography in 3 μm thickness. Use a guard column if necessary.

Column temperature: Maintain the temperature at 50°C for 3 minutes after injection, raise to 100°C at a rate of 10°C per minute, then to 250°C at a rate of 35°C per minute and maintain at 250°C for 8 minutes.

Injection port temperature: 250°C.

Detector temperature: 280°C.

Carrier gas: Helium.

Flow rate: 4.3 mL per minute (the retention time of the internal standard is about 10 minutes).

Split ratio: 1:40.

System suitability—

System performance: When the procedure is run with 1 to 2 μL of the standard solution under the above operating conditions, isopropyl iodide and the internal standard are eluted in this order with the resolution between these peaks being not less than 5.

System repeatability: When the test is repeated 6 times with 1 to 2 μL of the standard solution under the above operating conditions, the relative standard deviation of the ratio of the peak area of isopropyl iodide to that of the internal standard is not more than 2.0%.

Containers and storage Containers—Tight containers.

Hydroxyzine Hydrochloride

ヒドロキシジン塩酸塩

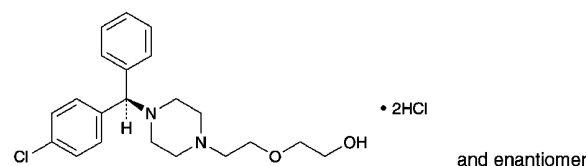

$\text{C}_{21}\text{H}_{27}\text{ClN}_2\text{O}_2 \cdot 2\text{HCl}$: 447.83

2-(2-{4-[(*RS*)-(4-Chlorophenyl)(phenyl)methyl]piperazin-1-yl}ethoxy)ethanol dihydrochloride
[2192-20-3]

Hydroxyzine Hydrochloride, when dried, contains not less than 98.5% of hydroxyzine hydrochloride ($\text{C}_{21}\text{H}_{27}\text{ClN}_2\text{O}_2 \cdot 2\text{HCl}$).

Description Hydroxyzine Hydrochloride occurs as a white crystalline powder. It is odorless, and has a bitter taste.

It is very soluble in water, freely soluble in methanol, in ethanol (95) and in acetic acid (100), very slightly soluble in acetic anhydride, and practically insoluble in diethyl ether.

Melting point: about 200°C (with decomposition).

Identification (1) To 5 mL of a solution of Hydroxyzine Hydrochloride (1 in 100) add 2 to 3 drops of ammonium thiocyanate-cobalt (II) nitrate TS: a blue precipitate is formed.

(2) Determine the absorption spectrum of a solution of Hydroxyzine Hydrochloride in methanol (1 in 100,000) as directed under Ultraviolet-visible Spectrophotometry <2.24>, and compare the spectrum with the Reference Spectrum: both spectra exhibit similar intensities of absorption at the same wavelengths.

(3) A solution of Hydroxyzine Hydrochloride (1 in 10) responds to Qualitative Tests <1.09> for chloride.

pH <2.54> Dissolve 1.0 g of Hydroxyzine Hydrochloride in 20 mL of water: the pH of this solution is between 1.3 and 2.5.

Purity (1) Clarity and color of solution—Dissolve 1.0 g of Hydroxyzine Hydrochloride in 10 mL of water: the solution is clear and colorless.

(2) Heavy metals <1.07>—Proceed with 1.0 g of Hydroxyzine Hydrochloride according to Method 2, and perform the test. Prepare the control solution with 2.0 mL of Standard Lead Solution (not more than 20 ppm).

(3) Related substances—Dissolve 0.20 g of Hydroxyzine Hydrochloride in 10 mL of methanol, and use this solution as the sample solution. Pipet 1 mL of the sample solution, add methanol to make exactly 200 mL, and use this solution as the standard solution. Perform the test with these solutions as directed under Thin-layer Chromatography <2.03>. Spot 5 μ L each of the sample solution and standard solution on a plate of silica gel for thin-layer chromatography. Develop the plate with a mixture of ethyl acetate, ethanol (95) and ammonia solution (28) (150:95:1) to a distance of about 10 cm, and air-dry the plate. Allow the plate to stand in iodine vapor: the spots other than the principal spot obtained from the sample solution are not more intense than the spot obtained from the standard solution.

Loss on drying <2.41> Not more than 3.0% (1 g, 105°C, 2 hours).

Residue on ignition <2.44> Not more than 0.2% (1 g).

Assay Weigh accurately about 0.1 g of Hydroxyzine Hydrochloride, previously dried, dissolve in 60 mL of a mixture of acetic anhydride and acetic acid (100) (7:3), and titrate <2.50> with 0.1 mol/L perchloric acid VS (potentiometric titration). Perform a blank determination in the same manner, and make any necessary correction.

Each mL of 0.1 mol/L perchloric acid VS
= 22.39 mg of $C_{21}H_{27}ClN_2O_2 \cdot 2HCl$

Containers and storage Containers—Tight containers.

Hydroxyzine Pamoate

ヒドロキシジンパモ酸塩

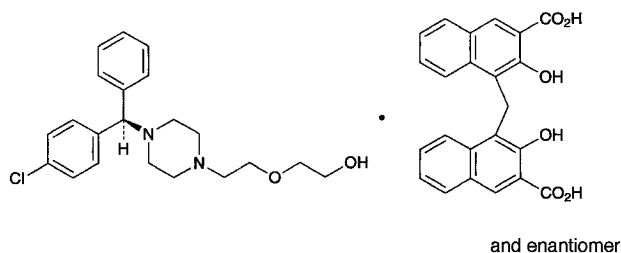

$C_{21}H_{27}ClN_2O_2 \cdot C_{23}H_{16}O_6$; 763.27

2-(2-{4-[(*RS*)-(4-Chlorophenyl)(phenyl)methyl]piperazin-1-yl}ethoxy)ethanol mono[4,4'-methylenebis(3-hydroxy-2-naphthoate)]
[10246-75-0]

Hydroxyzine Pamoate contains not less than 98.0% of hydroxyzine pamoate ($C_{21}H_{27}ClN_2O_2 \cdot C_{23}H_{16}O_6$), calculated on the anhydrous basis.

Description Hydroxyzine Pamoate occurs as a light yellow crystalline powder. It is odorless, and has a slightly bitter taste.

It is freely soluble in *N,N*-dimethylformamide, slightly soluble in acetone, and practically insoluble in water, in methanol, in ethanol (95) and in diethyl ether.

Identification (1) To 0.1 g of Hydroxyzine Pamoate add 25 mL of sodium hydroxide TS, and shake well. Extract with 20 mL of chloroform, and use the chloroform layer as the sample solution. Use the water layer for test (4). To 5 mL of the sample solution add 2 mL of ammonium thiocyanate-cobalt (II) nitrate TS, shake well, and allow to stand: a blue color is produced in the chloroform layer.

(2) Evaporate 2 mL of the sample solution obtained in (1) on a water bath to dryness, and dissolve the residue in 0.1 mol/L hydrochloric acid TS to make 500 mL. Determine the absorption spectrum of the solution as directed under Ultra-violet-visible Spectrophotometry <2.24>, and compare the spectrum with the Reference Spectrum: both spectra exhibit similar intensities of absorption at the same wavelengths.

(3) Perform the test with Hydroxyzine Pamoate as directed under Flame Coloration Test <1.04> (2): a green color appears.

(4) To 1 mL of the water layer obtained in (1), add 2 mL of 1 mol/L hydrochloric acid TS: a yellow precipitate is produced. Collect the precipitate, dissolve the precipitate in 5 mL of methanol, and add 1 drop of iron (III) chloride TS: a green color is produced.

Purity (1) Clarity and color of solution—Dissolve 1.0 g of Hydroxyzine Pamoate in 10 mL of *N,N*-dimethylformamide: the solution is clear, and shows a slightly greenish, light yellow-brown color.

(2) Chloride <1.03>—To 0.3 g of Hydroxyzine Pamoate add 6 mL of dilute nitric acid and 10 mL of water, shake for 5 minutes, and filter. Wash the residue with two 10-mL portions of water, combine the washings with the filtrate, and add water to make 50 mL. Perform the test using this solution as the test solution. Prepare the control solution with 0.80 mL of 0.01 mol/L hydrochloric acid VS (not more than 0.095%).

(3) Heavy metals <1.07>—Proceed with 1.0 g of Hydroxyzine Pamoate according to Method 2, and perform the test. Prepare the control solution with 2.0 mL of Standard Lead Solution (not more than 20 ppm).

(4) Arsenic <1.11>—Prepare the test solution with 2.0 g of Hydroxyzine Pamoate according to Method 3, and perform the test (not more than 1 ppm).

(5) Related substances—Dissolve 0.40 g of Hydroxyzine Pamoate in 10 mL of a mixture of sodium hydroxide TS and acetone (1:1), and use the solution as the sample solution. Pipet 1 mL of the sample solution, add a mixture of sodium hydroxide TS and acetone (1:1) to make exactly 20 mL. Pipet 5 mL of this solution, add a mixture of sodium hydroxide TS and acetone (1:1) to make exactly 50 mL, and use the solution as the standard solution. Perform the test with these solutions as directed under Thin-layer Chromatography <2.03>. Spot 5 μ L each of the sample solution and standard solution on a plate of silica gel for thin-layer chromatography. Develop the plate with a mixture of ethyl acetate, ethanol (95) and ammonia TS (150:95:1) to a distance of about 10 cm, and air-dry the plate. Spray evenly hydrogen hexachloroplatinate (IV)-potassium iodide TS on the plate: the spots other than hydroxyzine and pamoic acid obtained from the sample solution are not more intense than the spot from the standard solution.

Water <2.48> Not more than 3.0% (1 g, volumetric titration, direct titration).

Residue on ignition <2.44> Not more than 0.5% (1 g).

Assay Weigh accurately about 0.6 g of Hydroxyzine Pamoate, add 25 mL of sodium hydroxide TS, shake well, and extract with six 25-mL portions of chloroform. Filter each extract through 5 g of anhydrous sodium sulfate on a pledget of absorbent cotton. Combine the chloroform extracts, and evaporate the combined chloroform extracts on a water bath to about 30 mL. Add 30 mL of acetic acid (100), and titrate <2.50> with 0.1 mol/L perchloric acid VS until the color of the solution changes from purple through blue to blue-green (indicator: 2 drops of crystal violet TS). Perform a blank de-

termination in the same manner, and make any necessary correction.

Each mL of 0.1 mol/L perchloric acid VS
= 38.16 mg of $C_{21}H_{27}ClN_2O_2 \cdot C_{23}H_{16}O_6$

Containers and storage Containers—Tight containers.

Hymecromone

ヒメクロモン

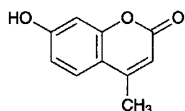

$C_{10}H_8O_3$: 176.17
7-Hydroxy-4-methylchromen-2-one
[90-33-5]

Hymecromone, when dried, contains not less than 98.0% of hymecromone ($C_{10}H_8O_3$).

Description Hymecromone occurs as white, crystals or crystalline powder. It is odorless and tasteless.

It is freely soluble in *N,N*-dimethylformamide, sparingly soluble in ethanol (95), in ethanol (99.5) and in acetone, slightly soluble in diethyl ether, and practically insoluble in water.

Identification (1) Dissolve 2 mg of Hymecromone in 5 mL of ammonia-ammonium chloride buffer solution (pH 11.0): the solution shows an intense blue-purple fluorescence.

(2) Dissolve 25 mg of Hymecromone in 5 mL of diluted ethanol (95) (1 in 2), and add 1 drop of iron (III) chloride TS: initially a blackish brown color develops, and when allowed to stand the color changes to yellow-brown.

(3) Determine the absorption spectrum of a solution of Hymecromone in ethanol (99.5) (1 in 250,000) as directed under Ultraviolet-visible Spectrophotometry <2.24>, and compare the spectrum with the Reference Spectrum: both spectra exhibit similar intensities of absorption at the same wavelengths.

(4) Determine the infrared absorption spectrum of Hymecromone, previously dried, as directed in the potassium bromide disk method under Infrared Spectrophotometry <2.25>, and compare the spectrum with the Reference Spectrum: both spectra exhibit similar intensities of absorption at the same wave numbers.

Melting point <2.60> 187 – 191°C

Purity (1) Chloride <1.03>—Dissolve 0.8 g of Hymecromone in 40 mL of a mixture of acetone and water (2:1), and add 6 mL of dilute nitric acid and a mixture of acetone and water (2:1) to make 50 mL. Perform the test using this solution as the test solution. Prepare the control solution as follows: to 0.25 mL of 0.01 mol/L hydrochloric acid VS add 6 mL of dilute nitric acid and a mixture of acetone and water (2:1) to make 50 mL (not more than 0.011%).

(2) Sulfate <1.14>—Dissolve 0.8 g of Hymecromone in 40 mL of a mixture of acetone and water (2:1), and add 1 mL of dilute hydrochloric acid and a mixture of acetone and water (2:1) to make 50 mL. Perform the test using this solution as the test solution. Prepare the control solution as follows: to 0.40 mL of 0.005 mol/L sulfuric acid VS add 1 mL of dilute hydrochloric acid and a mixture of acetone and

water (2:1) to make 50 mL (not more than 0.024%).

(3) Heavy metals <1.07>—Proceed with 2.0 g of Hymecromone according to Method 2, and perform the test. Prepare the control solution with 2.0 mL of Standard Lead Solution (not more than 10 ppm).

(4) Arsenic <1.11>—Prepare the test solution with 1.0 g of Hymecromone according to Method 3, and perform the test (not more than 2 ppm).

(5) Related substances—Dissolve 80 mg of Hymecromone in 10 mL of ethanol (95), and use this solution as the sample solution. Pipet 1 mL of the sample solution, and add ethanol (95) to make exactly 50 mL. Pipet 1 mL of this solution, add ethanol (95) to make exactly 20 mL, and use this solution as the standard solution. Perform the test with these solutions as directed under Thin-layer Chromatography <2.03>. Spot 10 μ L each of the sample solution and standard solution on a plate of silica gel for thin-layer chromatography. Develop the plate with a mixture of chloroform and ethanol (95) (10:1) to a distance of about 10 cm, and air-dry the plate. Allow the plate to stand in iodine vapor for 5 minutes: the spots other than the principal spot obtained from the sample solution are not more intense than the spot from the standard solution.

Loss on drying <2.41> Not more than 0.5% (1 g, 105°C, 4 hours).

Residue on ignition <2.44> Not more than 0.1% (1 g).

Assay Weigh accurately about 0.25 g of Hymecromone, previously dried, dissolve in 90 mL of *N,N*-dimethylformamide, and titrate <2.50> with 0.1 mol/L tetramethylammonium hydroxide VS (potentiometric titration). Separately, perform a blank determination in the same manner with a solution prepared by adding 14 mL of water to 90 mL of *N,N*-dimethylformamide, and make any necessary correction.

Each mL of 0.1 mol/L tetramethylammonium hydroxide VS
= 17.62 mg of $C_{10}H_8O_3$

Containers and storage Containers—Tight containers.

Hypromellose

ヒプロメロース

[9004-65-3]

This monograph is harmonized with the European Pharmacopoeia and the U.S. Pharmacopoeia.

The corresponding part of the attributes/provisions which are agreed as non-harmonized within the scope of the harmonization is marked with symbols (◆ ◆), and the corresponding parts which are agreed as the JP local requirement other than the scope of the harmonization are marked with symbols (◇ ◇).

Information on the harmonization with the European Pharmacopoeia and the U.S. Pharmacopoeia is available on the website of the Pharmaceuticals and Medical Devices Agency.

Hypromellose is a methyl and hydroxypropyl mixed ether of cellulose.

There are four substitution types of Hypromellose, 1828, 2208, 2906 and 2910. They contain methoxy ($-OCH_3$: 31.03) and hydroxypropoxy ($-OC_3H_6OH$:

75.09) groups conforming to the limits for the types of Hypromellose shown in the table below, calculated on the dried basis.

The viscosity is shown in millipascal second (mPa·s) on the label, together with the substitution type.

Substitution Type	Methoxy Group (%)		Hydroxypropoxy Group (%)	
	Min.	Max.	Min.	Max.
1828	16.5	20.0	23.0	32.0
2208	19.0	24.0	4.0	12.0
2906	27.0	30.0	4.0	7.5
2910	28.0	30.0	7.0	12.0

◆**Description** Hypromellose occurs as a white to yellowish white, powder or grains.

It is practically insoluble in ethanol (99.5).

It swells with water and becomes a clear or slightly turbid, viscous solution.◆

Identification (1) Disperse evenly 1.0 g of Hypromellose over the surface of 100 mL of water in a beaker, while gently tapping the top of the beaker, if necessary, and allow the beaker to stand: it aggregates on the surface of water.

(2) Add 1.0 g of Hypromellose to 100 mL of hot water, and stir: it becomes a suspension. Cool the suspension to 10°C, and stir: the resulting liquid is a clear or a slightly cloudy, viscous fluid.

(3) To 0.1 mL of the viscous fluid obtained in (2) add 9 mL of diluted sulfuric acid (9 in 10), shake, heat in a water bath for exactly 3 minutes, and immediately cool in ice water. Add carefully 0.6 mL of ninhydrin TS, shake, and allow to stand at 25°C: the solution shows a red color first, then changes to purple color within 100 minutes.

(4) Pour and spread out 2 to 3 mL of the viscous fluid obtained in (2) onto a glass plate, and allow the water to evaporate: a transparent film results.

(5) Pipet 50 mL of water, add exactly 50 mL of the viscous fluid obtained in (2), and warm to raise the temperature at a rate of 2 to 5°C per minute while stirring: the temperature, when a white turbidity of the solution starts to increase, is not less than 50°C.

Viscosity <2.53> (i) Method I: Apply to Hypromellose having a labeled viscosity of less than 600 mPa·s. Put an exact amount of Hypromellose, equivalent to 4.000 g calculated on the dried basis, in a tared, wide-mouth bottle, add water (between 90°C and 99°C) to make 200 g, stopper the bottle, stir by mechanical means at 350 to 450 revolutions per minute for 10 to 20 minutes to get a homogeneous dispersion. If necessary, take off the sample attached on the walls of the bottle, put them in the dispersed solution, and dissolve by continuing the stirring in a water bath at not exceeding 10°C for 20 to 40 minutes. Add cold water, if necessary, to make 200 g, and use this solution as the sample solution. Centrifuge the solution if necessary to expel any entrapped air bubbles. Perform the test with the sample solution at 20 ± 0.1°C as directed in Method I under Viscosity Determination: not less than 80% and not more than 120% of the labeled viscosity.

(ii) Method II: Apply to Hypromellose having a labeled viscosity of not less than 600 mPa·s. Put an exact amount of Hypromellose, equivalent to 10.00 g calculated on the dried basis, in a tared, wide-mouth bottle, add water (between 90°C and 99°C) to make 500 g, and prepare the sample solution in the same manner as directed in Method I. Perform

the test with the sample solution at 20 ± 0.1°C as directed in Method II under Viscosity Determination, using a single cylinder-type rotational viscometer, according to the following operating conditions: not less than 75% and not more than 140% of the labeled viscosity.

Operating conditions—

Apparatus: Brookfield type viscometer LV model or an equivalent apparatus.

Rotor No., rotation frequency, and calculation multiplier: According to the following table, depending on the labeled viscosity.

Labeled viscosity (mPa·s)	Rotor No.	Rotation frequency /min	Calculation multiplier
Not less than 600 and less than 1400	3	60	20
" 1400 "	3500	3	12
" 3500 "	9500	4	60
" 9500 "	99,500	4	6
" 99,500 "	4	3	2000

Procedure of apparatus: Read the value after 2 minutes of rotation, and stop the rotation for at least 2 minutes. Repeat this procedure more two times, and average the three observed values.

pH <2.54> The pH of the sample solution obtained in the Viscosity, measured after 5 minutes immersing the electrode in the sample solution, is between 5.0 and 8.0.

◇**Purity** Heavy metals—Put 1.0 g of Hypromellose in a 100-mL Kjeldahl flask, add a sufficient amount of a mixture of nitric acid and sulfuric acid (5:4) to wet the sample, and heat gently. Repeat this procedure until to use totally 18 mL of the mixture of nitric acid and sulfuric acid (5:4). Then boil gently until the solution changes to black. After cooling, add 2 mL of nitric acid, and heat until the solution changes to black. Repeat this procedure until the solution no longer changes to black, and heat strongly until dense white fumes are evolved. After cooling, add 5 mL of water, boil gently until dense white fumes are evolved, then heat until the volume of the solution becomes to 2 to 3 mL. After cooling, if the solution reveals yellow color by addition of 5 mL of water, add 1 mL of hydrogen peroxide (30), and heat until the volume of the solution becomes to 2 to 3 mL. After cooling, dilute the solution with 2 to 3 mL of water, transfer to a Nessler tube, add water to make 25 mL, and use this solution as the sample solution. Separately, put 2.0 mL of Standard Lead Solution in a 100-mL Kjeldahl flask, add 18 mL of the mixture of nitric acid and sulfuric acid (5:4) and an amount of nitric acid equal to that used for preparation of the sample solution, and heat until white fumes are evolved. After cooling, add 10 mL of water. In the case where hydrogen peroxide (30) is added for the preparation of the sample solution, add the same amount of hydrogen peroxide (30), then proceed in the same manner for preparation of the sample solution, and use so obtained solution as the control solution. Adjust the sample solution and the control solution to pH 3.0 to 4.0 with ammonia solution (28), and add water to make 40 mL, respectively. To these solutions add 1.2 mL of thioacetamide-alkaline glycerin TS, 2 mL of acetate buffer solution (pH 3.5) and water to make 50 mL, separately. After allowing to stand for 5 minutes, observe vertically both tubes on a white background: the color obtained with the sample solution is not more intense than that with the control solution (not more than 20 ppm).◇

Loss on drying <2.41> Not more than 5.0% (1 g, 105°C,

1 hour).

Residue on ignition <2.44> Not more than 1.5% (1 g).

Assay (i) Apparatus—Reaction vial: A 5-mL pressure-tight serum vial, having 20 mm in outside diameter and 50 mm in height, the neck 20 mm in outside diameter and 13 mm in inside diameter, equipped with a septum of butyl-rubber processed the surface with fluoroplastics, which can be fixed tightly to vial with aluminum cap, or equivalent.

Heater: A square-shaped aluminum block, having holes 20 mm in diameter and 32 mm in depth, adopted to the reaction vial. Capable of stirring the content of the reaction vial by means of magnetic stirrer or of reciprocal shaker about 100 times per minute.

(ii) Procedure—Weigh accurately about 65 mg of Hypromellose, transfer to a reaction vial, add 60 to 100 mg of adipic acid, 2.0 mL of the internal standard solution and 2.0 mL of hydroiodic acid, immediately stopper the vial tightly, and weigh accurately. Using a magnetic stirrer equipped in the heating module, or using a shaker, stir for 60 minutes while heating so that the temperature of the vial content is $130 \pm 2^\circ\text{C}$. In the case when a magnetic stirrer or shaker is not available, heat for 30 minutes with repeated shaking at 5-minute intervals by hand, and continue heating for an additional 30 minutes. Allow the vial to cool, and again weigh accurately. If the mass loss is less than 26 mg and there is no evidence of a leak of the content, use the upper layer of the mixture as the sample solution. Separately, put 60 to 100 mg of adipic acid, 2.0 mL of the internal standard solution and 2.0 mL of hydroiodic acid in a reaction vial, immediately stopper the vial tightly, and weigh accurately. Add 45 μL of iodomethane for assay and 15 to 22 μL of isopropyl iodide for assay through the septum using a micro-syringe with weighing accurately every time, shake thoroughly, and use the upper layer of the content as the standard solution. Perform the test with 1 to 2 μL each of the sample solution and standard solution as directed under Gas Chromatography <2.02> according to the following conditions, and calculate the ratios, Q_{Ta} and Q_{Tb} , of the peak area of iodomethane and isopropyl iodide to that of the internal standard obtained from the sample solution, and Q_{Sa} and Q_{Sb} , of the peak area of iodomethane and isopropyl iodide to that of the internal standard from the standard solution.

$$\begin{aligned} \text{Content (\% of methoxy group (CH}_3\text{O)} \\ = M_{\text{Sa}}/M \times Q_{\text{Ta}}/Q_{\text{Sa}} \times 21.86 \end{aligned}$$

$$\begin{aligned} \text{Content (\% of hydroxypropoxy group (C}_3\text{H}_7\text{O}_2) \\ = M_{\text{Sb}}/M \times Q_{\text{Tb}}/Q_{\text{Sb}} \times 44.17 \end{aligned}$$

M_{Sa} : Amount (mg) of iodomethane for assay taken

M_{Sb} : Amount (mg) of isopropyl iodide for assay taken

M : Amount (mg) of Hypromellose taken, calculated on the dried basis

Internal standard solution—A solution of *n*-octane in *o*-xylene (3 in 100).

Operating conditions—

Detector: A thermal conductivity detector or hydrogen flame-ionization detector.

Column: A fused silica column 0.53 mm in inside diameter and 30 m in length, coated with dimethylpolysiloxane for gas chromatography in 3 μm thickness. Use a guard column, if necessary.

Column temperature: Maintain the temperature at 50°C for 3 minutes, raise to 100°C at a rate of 10°C per minute, then raise to 250°C at a rate of 35°C per minute, and maintain at 250°C for 8 minutes.

Injection port temperature: A constant temperature of about 250°C .

Detector temperature: A constant temperature of about 280°C .

Carrier gas: Helium.

Flow rate: 4.3 mL per minute (the retention time of the internal standard is about 10 minutes).

Split ratio: 1:40.

System suitability—

System performance: When the procedure is run with 1 – 2 μL of the standard solution under the above operating conditions, iodomethane, isopropyl iodide and the internal standard are eluted in this order with the resolution between these peaks being not less than 5.

System repeatability: When the test is repeated 6 times with 1 – 2 μL of the standard solution under the above operating conditions, the relative standard deviations of the ratio of the peak area of iodomethane and isopropyl iodide to that of the internal standard are not more than 2.0%, respectively.

◆**Containers and storage** Containers—Well-closed containers.◆

Hypromellose Acetate Succinate

ヒプロメロース酢酸エステルコハク酸エステル

[71138-97-1]

Hypromellose Acetate Succinate is an acetic acid and monosuccinic acid mixed ester of hypromellose.

It contains not less than 12.0% and not more than 28.0% of methoxy group ($-\text{OCH}_3$; 31.03), not less than 4.0 and not more than 23.0% of hydroxypropoxy group ($-\text{OC}_3\text{H}_6\text{OH}$; 75.09), not less than 2.0% and not more than 16.0% of acetyl group ($-\text{COCH}_3$; 43.04), and not less than 4.0% and not more than 28.0% of succinyl group ($-\text{COC}_2\text{H}_4\text{COOH}$; 101.08), calculated on the dried basis.

Its viscosity is expressed in millipascal second ($\text{mPa}\cdot\text{s}$).

Description Hypromellose Acetate Succinate occurs as a white to yellowish white, powder or granules.

It is practically insoluble in water and in ethanol (99.5).

It dissolves in sodium hydroxide TS.

It is hygroscopic.

Identification Determine the infrared absorption spectrum of Hypromellose Acetate Succinate as directed in the ATR method under Infrared Spectrophotometry <2.25>: it exhibits absorption at the wave numbers of about 2840 cm^{-1} , 1737 cm^{-1} , 1371 cm^{-1} , 1231 cm^{-1} and 1049 cm^{-1} .

Viscosity <2.53> To 2.00 g of Hypromellose Acetate Succinate, previously dried, add dilute sodium hydroxide TS to make 100.0 g, stopper tightly, and dissolve by shaking for 30 minutes. Perform the test with this solution at 20°C according to Method 1: 80 – 120% of the labeled viscosity.

Purity (1) Heavy metals <1.07>—Proceed with 2.0 g of Hypromellose Acetate Succinate according to Method 2, and perform the test. Prepare the control solution with 2.0 mL of Standard Lead Solution (not more than 10 ppm).

(2) Free acetic acid and free succinic acid—Weigh accurately about 0.1 g of Hypromellose Acetate Succinate, add exactly 4 mL of 0.02 mol/L phosphate buffer solution (pH

7.5), stopper tightly, and stir for 2 hours. Then add exactly 4 mL of diluted phosphoric acid (1 in 500), turn the test tube upside down several times, centrifuge, and use the supernatant liquid as the sample solution. Separately, place 20 mL of water in a 100-mL volumetric flask, weigh the mass of the flask accurately, then add 2.0 mL of acetic acid (100), weigh the mass of the flask to calculate the accurate mass of added acetic acid, and dilute with water to volume. Pipet 6 mL of this solution, add water to make exactly 100 mL, and use this solution as the acetic acid stock solution. Separately, weigh accurately about 0.13 g of succinic acid, dissolve in water to make exactly 100 mL, and use this solution as the succinic acid stock solution. Pipet exactly 4 mL each of the acetic acid stock solution and the succinic acid stock solution, add the mobile phase to make exactly 25 mL, and use this solution as the standard solution. Perform the test with exactly 10 μ L each of the sample solution and standard solution as directed under Liquid Chromatography <2.01> according to the following conditions. Determine the peak areas of acetic acid and succinic acid of both solutions, A_{TA} , A_{TS} and A_{SA} , A_{SS} , and calculate the amount of free acetic acid and free succinic acid by the following expressions: the total amount is not more than 1.0%.

$$\begin{aligned} \text{Amount (\% of free acetic acid (C}_2\text{H}_4\text{O}_2)) \\ = M_{SA}/M_T \times A_{TA}/A_{SA} \times 48/625 \end{aligned}$$

$$\begin{aligned} \text{Amount (\% of free succinic acid (C}_4\text{H}_6\text{O}_4)) \\ = M_{SS}/M_T \times A_{TS}/A_{SS} \times 32/25 \end{aligned}$$

M_{SA} : Amount (mg) of acetic acid (100) taken

M_{SS} : Amount (mg) of succinic acid taken

M_T : Amount (mg) of Hypromellose Acetate Succinate taken, calculated on the dried basis

Operating conditions—

Proceed as directed in the operating conditions in the Assay (1).

System suitability—

System performance and system repeatability: Proceed as directed in the system suitability in the Assay (1).

Test for required detectability: To 3 mL of the standard solution add the mobile phase to make 10 mL, and use this solution as the solution for system suitability test. Pipet 1 mL of the solution for system suitability test, and add the mobile phase to make exactly 10 mL. Confirm that the peak areas of acetic acid and succinic acid obtained with 10 μ L of this solution are equivalent to 7 to 13% of corresponding those with 10 μ L of the solution for system suitability test.

Loss on drying <2.41> Not more than 5.0% (1 g, 105°C, 1 hour).

Residue on ignition <2.44> Not more than 0.2% (1 g).

Assay (1) Acetyl group and succinyl group—Weigh accurately about 30 mg of Hypromellose Acetate Succinate, add exactly 10 mL of sodium hydroxide TS, stopper tightly, and stir for 4 hours. Add exactly 10 mL of diluted phosphoric acid (17 in 200), turn the test tube upside down several times, and filter the solution through a membrane filter with a pore size 0.22 μ m. Discard the first 1 mL of the filtrate, and use the subsequent filtrate as the sample solution. Separately, place 20 mL of water in a 100-mL volumetric flask, weigh the mass of the flask accurately, then add 2.0 mL of acetic acid (100), weigh the mass of the flask to calculate the accurate mass of added acetic acid, and dilute with water to volume. Pipet 6 mL of this solution, add water to make exactly 100 mL, and use this solution as the acetic acid stock solution. Separately, weigh accurately about 0.13 g of suc-

cinic acid, dissolve in water to make exactly 100 mL, and use this solution as the succinic acid stock solution. Pipet 4 mL each of the acetic acid stock solution and the succinic acid stock solution, add the mobile phase to make exactly 25 mL, and use this solution as the standard solution. Perform the test with exactly 10 μ L each of the sample solution and standard solution as directed under Liquid Chromatography <2.01> according to the following conditions, and determine the peak areas, A_{TA} , A_{TS} and A_{SA} , A_{SS} , of acetic acid and succinic acid in each solution.

$$\begin{aligned} \text{Amount (\% of acetyl group (C}_2\text{H}_3\text{O)} \\ = (M_{SA}/M_T \times A_{TA}/A_{SA} \times 24/125 - A_{\text{free}}) \times 0.717 \end{aligned}$$

$$\begin{aligned} \text{Amount (\% of succinyl group (C}_4\text{H}_5\text{O}_3)) \\ = (M_{SS}/M_T \times A_{TS}/A_{SS} \times 16/5 - S_{\text{free}}) \times 0.856 \end{aligned}$$

M_{SA} : Amount (mg) of acetic acid (100) taken

M_{SS} : Amount (mg) of succinic acid taken

M_T : Amount (mg) of Hypromellose Acetate Succinate taken, calculated on the dried basis

A_{free} : Amount (%) of free acetic acid obtained in the Purity (2)

S_{free} : Amount (%) of free succinic acid obtained in the Purity (2)

Operating conditions—

Detector: An ultraviolet absorption photometer (wavelength: 215 nm).

Column: A stainless steel column 4.6 mm in inside diameter and 15 cm in length, packed with octadecylsilanized silica gel for liquid chromatography (5 μ m in particle diameter).

Column temperature: A constant temperature of about 25°C.

Mobile phase: 0.02 mol/L potassium dihydrogen phosphate TS, adjusted to pH 2.8 with phosphoric acid.

Flow rate: Adjust so that the retention time of succinic acid is about 7 minutes.

System suitability—

System performance: When the procedure is run with 10 μ L of the standard solution under the above operating conditions, acetic acid and succinic acid are eluted in this order with the resolution between these peaks being not less than 5.

System repeatability: When the test is repeated 6 times with 10 μ L of the standard solution under the above operating conditions, the relative standard deviation of the peak areas of acetic acid and succinic acid is not more than 2.0%.

(2) Methoxy group and hydroxypropoxy group

(i) Apparatus—Reaction bottle: A 5 mL pressure-tight glass vial, having 20 mm in outside diameter, 50 mm in height, the neck 20 mm in outside diameter and 13 mm in inside diameter, equipped with a septum of butyl rubber processed the surface with fluoroplastics, which can be fixed tightly to vial with aluminum cap, or equivalent.

Heater: A square-shaped aluminum block, having holes 20 mm in inside diameter and 32 mm in depth, adopted to the reaction bottle. Capable of stirring the content of the bottle by means of magnetic stirrer or reciprocal shaker about 100 times per minute.

(ii) Procedure—Weigh accurately about 65 mg of Hypromellose Acetate Succinate, place in the reaction bottle, add 0.06 to 0.10 g of adipic acid, 2.0 mL of the internal standard solution and 2.0 mL of hydriodic acid, stopper the bottle immediately, and weigh accurately. Stir or shake for 60 minutes while heating so that the temperature of the bottle content is $130 \pm 2^\circ\text{C}$. In a case where the magnetic stirrer or shaker is not available, heat for 30 minutes with repeated shaking at 5 minute intervals by hand, and continue heating for additional 30 minutes. Allow the bottle to cool,

and again weigh accurately. If the mass loss is less than 0.50% or there is no evidence of a leak, use the upper layer of the mixture as the sample solution. Separately, put 0.06 to 0.10 g of adipic acid, 2.0 mL of the internal standard solution and 2.0 mL of hydriodic acid in a reaction bottle, stopper the bottle immediately, and weigh accurately. Add 45 μL of iodomethane for assay and 15 to 22 μL of isopropyl iodide for assay through the septum using a micro-syringe with weighing accurately every time, stir thoroughly, and use the upper layer of the mixture as the standard solution. Perform the test with 1 to 2 μL each of the sample solution and standard solution as directed under Gas Chromatography <2.02> according to the following conditions, and calculate the ratios of the peak areas of iodomethane and isopropyl iodide to the peak area of the internal standard, Q_{Ta} , Q_{Tb} and Q_{Sa} , Q_{Sb} .

$$\begin{aligned} \text{Amount (\%)} \text{ of methoxy group (CH}_3\text{O)} \\ = M_{\text{Sa}}/M_{\text{T}} \times Q_{\text{Ta}}/Q_{\text{Sa}} \times 21.86 \end{aligned}$$

$$\begin{aligned} \text{Amount (\%)} \text{ of hydroxypropoxy group (C}_3\text{H}_7\text{O}_2) \\ = M_{\text{Sb}}/M_{\text{T}} \times Q_{\text{Tb}}/Q_{\text{Sb}} \times 44.17 \end{aligned}$$

M_{Sa} : Amount (mg) of iodomethane for assay taken

M_{Sb} : Amount (mg) of isopropyl iodide for assay taken

M_{T} : Amount (mg) of Hypromellose Acetate Succinate taken, calculated on the dried basis

Internal standard solution—A solution of *n*-octane in *o*-xylene (3 in 100).

Operating conditions—

Detector: A thermal conductivity detector or hydrogen flame-ionization detector.

Column: A glass tube 3–4 mm in inside diameter and 1.8–3 m in length, packed with siliceous earth for gas chromatography, 120 to 150 μm in diameter coated with methyl silicon polymer for gas chromatography in 10–20%.

Column temperature: A constant temperature of about 100°C.

Carrier gas: Helium for the thermal conductivity detector, or Helium or Nitrogen for the hydrogen flame-ionization detector.

Flow rate: Adjust so that the retention time of the internal standard is about 10 minutes.

System suitability—

System performance: When the procedure is run with 1–2 μL of the standard solution under the above operating conditions, iodomethane, isopropyl iodide and the internal standard are eluted in this order with the resolution between each peak being not less than 5.

System repeatability: When the test is repeated 6 times with 1–2 μL of the standard solution under the above operating conditions, the relative standard deviations of the ratio of the peak area of iodomethane and isopropyl iodide to that of the internal standard are not more than 2.0%, respectively.

Containers and storage Containers—Tight containers.

Hypromellose Phthalate

ヒプロメロースフタル酸エステル

[9050-31-1]

This monograph is harmonized with the European Pharmacopoeia and the U.S. Pharmacopoeia.

The parts of the text that are not harmonized are marked with symbols (◆ ◆).

Information on the harmonization with the European Pharmacopoeia and the U.S. Pharmacopoeia is available on the website of the Pharmaceuticals and Medical Devices Agency.

Hypromellose Phthalate is a monophthalic acid ester of hypromellose.

It contains methoxy group (–OCH₃: 31.03), hydroxypropoxy group (–OCH₂CHOHCH₃: 75.09), and carboxybenzoyl group (–COC₆H₄COOH: 149.12).

It contains not less than 21.0% and not more than 35.0% of carboxybenzoyl group, calculated on the anhydrous basis.

◆Its substitution type and its viscosity in millipascal second (mPa·s) are shown on the label.

Substitution Type	Carboxybenzoyl group (%)	
	Min.	Max.
200731	27.0	35.0
220824	21.0	27.0

◆

◆**Description** Hypromellose Phthalate occurs as white, powder or granules.

It is practically insoluble in water, in acetonitrile and in ethanol (99.5).

It becomes a viscous liquid when a mixture of methanol and dichloromethane (1:1) or a mixture of ethanol (99.5) and acetone (1:1) is added.

It dissolves in sodium hydroxide TS.◆

◆**Identification** Determine the infrared absorption spectrum of Hypromellose Phthalate as directed in the potassium bromide disk method under Infrared Spectrophotometry <2.25>, and compare the spectrum with the Reference Spectrum: both spectra exhibit similar intensities of absorption at the same wave numbers.◆

Viscosity <2.53> To 10 g of Hypromellose Phthalate, previously dried at 105°C for 1 hour, add 90 g of a mixture of methanol and dichloromethane in equal mass ratio, and stir to dissolve. Determine the viscosity at 20 ± 0.1°C as directed in Method 1 under Viscosity Determination: the viscosity is not less than 80% and not more than 120% of the labeled unit.

Purity (1) Chloride <1.03>—Dissolve 1.0 g of Hypromellose Phthalate in 40 mL of 0.2 mol/L sodium hydroxide VS, add 1 drop of phenolphthalein TS, and add dilute nitric acid dropwise with vigorous stirring until the red color is discharged. Further add 20 mL of dilute nitric acid with stirring. Heat on a water bath with stirring until the gelatinous precipitate formed turns to granular particles. After cooling, centrifuge, and take off the supernatant liquid. Wash the precipitate with three 20-mL portions of water by centrifug-

ing each time, combine the supernatant liquid and the washings, add water to make 200 mL, and filter. Perform the test with 50 mL of the filtrate. Control solution: To 0.50 mL of 0.01 mol/L hydrochloric acid VS add 10 mL of 0.2 mol/L sodium hydroxide VS and 7 mL of dilute nitric acid, and add water to make 50 mL (not more than 0.07%).

◆(2) Heavy metals <1.07>—Proceed with 2.0 g of Hypromellose Phthalate according to Method 2, and perform the test. Prepare the control solution with 2.0 mL of Standard Lead Solution (not more than 10 ppm).◆

(3) Phthalic acid—Weigh accurately about 0.2 g of Hypromellose Phthalate, add about 50 mL of acetonitrile to dissolve partially with the aid of ultrasonic waves, add 10 mL of water, and dissolve further with the ultrasonic waves. After cooling, add acetonitrile to make exactly 100 mL, and use this solution as the sample solution. Separately, weigh accurately about 12.5 mg of phthalic acid, dissolve in about 125 mL of acetonitrile by mixing, add 25 mL of water, then add acetonitrile to make exactly 250 mL, and use this solution as the standard solution. Perform the test with exactly 10 μ L each of the sample solution and standard solution as directed under Liquid Chromatography <2.01> according to the following conditions, and determine the peak areas, A_T and A_S , of phthalic acid in each solution: amount of phthalic acid ($C_8H_6O_4$: 166.13) is not more than 1.0%.

$$\text{Amount (\% of phthalic acid)} = M_S/M_T \times A_T/A_S \times 40$$

M_S : Amount (mg) of phthalic acid taken

M_T : Amount (mg) of Hypromellose Phthalate taken, calculated on the anhydrous basis

Operating conditions—

Detector: An ultraviolet absorption photometer (wavelength: 235 nm).

Column: A stainless steel column about 4.6 mm in inside diameter and 25 cm in length, packed with octadecylsilanized silica gel for liquid chromatography (3 to 10 μ m in particle diameter).

Column temperature: A constant temperature of about 20°C.

Mobile phase: A mixture of 0.1% trifluoroacetic acid and acetonitrile (9:1).

Flow rate: About 2.0 mL per minute.

System suitability—

◆System performance: When the procedure is run with 10 μ L of the standard solution under the above operating conditions, the number of theoretical plates and the symmetry factor of the peak of phthalic acid are not less than 2500 and not more than 1.5, respectively.◆

System repeatability: When repeat the test 6 times with 10 μ L of the standard solution under the above operating conditions, the relative standard deviation of the peak area of phthalic acid is not more than 1.0%.

Water <2.48> Not more than 5.0% (1 g, volumetric titration, direct titration, using a mixture of ethanol (99.5) and dichloromethane (3:2) instead of methanol for water determination).

Residue on ignition <2.44> Not more than 0.2% (1 g).

Assay Weigh accurately about 1 g of Hypromellose Phthalate, dissolve in 50 mL of a mixture of ethanol (95), acetone and water (2:2:1), and titrate <2.50> with 0.1 mol/L sodium hydroxide VS (indicator: 2 drops of phenolphthalein TS). Perform a blank determination in the same manner, and make any necessary correction.

Amount (%) of carboxybenzoyl group ($C_8H_5O_3$)

$$= \{(0.01 \times 149.1 \times V)/M\} - \{(2 \times 149.1 \times P)/166.1\}$$

P : Amount (%) of phthalic acid obtained in the Purity (3)

V : Amount (mL) of 0.1 mol/L sodium hydroxide VS consumed

M : Amount (g) of Hypromellose Phthalate taken, calculated on the anhydrous basis

Containers and storage Containers—Tight containers.

Ibutilast

イブジラスト

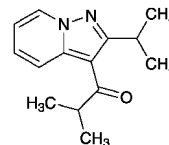

$C_{14}H_{18}N_2O$: 230.31

1-[2-(1-Methylethyl)pyrazolo[1,5-*a*]pyridin-3-yl]-

2-methylpropan-1-one

[50847-11-5]

Ibutilast, when dried, contains not less than 98.5% and not more than 101.0% of ibutilast ($C_{14}H_{18}N_2O$).

Description Ibutilast occurs as a white crystalline powder.

It is very soluble in methanol, freely soluble in ethanol (99.5) and in acetic anhydride, and very slightly soluble in water.

Identification (1) Determine the absorption spectrum of a solution of Ibutilast in methanol (1 in 250,000) as directed under Ultraviolet-visible Spectrophotometry <2.24>, and compare the spectrum with the Reference Spectrum: both spectra exhibit similar intensities of absorption at the same wavelengths.

(2) Determine the infrared absorption spectrum of Ibutilast as directed in the potassium bromide disk method under Infrared Spectrophotometry <2.25>, and compare the spectrum with the Reference Spectrum: both spectra exhibit similar intensities of absorption at the same wave numbers.

Melting point <2.60> 54 – 58°C

Purity (1) Heavy metals <1.07>—Proceed with 1.0 g of Ibutilast according to Method 2, and perform the test. Prepare the control solution with 2.0 mL of Standard Lead Solution (not more than 20 ppm).

(2) Related substances—Dissolve 50 mg of Ibutilast in 50 mL of the mobile phase, and use this solution as the sample solution. Pipet 1 mL of the sample solution, and add the mobile phase to make exactly 50 mL. Pipet 1 mL of this solution, add the mobile phase to make exactly 20 mL, and use this solution as the standard solution. Perform the test with exactly 10 μ L each of the sample solution and standard solution as directed under Liquid Chromatography <2.01> according to the following conditions, and determine each peak area by the automatic integration method: each peak area other than ibutilast obtained from the sample solution is not larger than the peak area of ibutilast from the standard solution, and the total area of the peaks other than ibutilast is not larger than 3 times the peak area of ibutilast from the standard solution.

Operating conditions—

Detector: An ultraviolet absorption photometer (wave-

length: 292 nm).

Column: A stainless steel column 2.6 mm in inside diameter and 15 cm in length, packed with silica gel for liquid chromatography (5 μ m in particle diameter).

Column temperature: A constant temperature of about 25°C.

Mobile phase: A mixture of hexane and ethyl acetate (50:1).

Flow rate: Adjust so that the retention time of ibudilast is about 9 minutes.

Time span of measurement: About 4 times as long as the retention time of ibudilast, beginning after the solvent peak.

System suitability—

Test for required detectability: To exactly 5 mL of the standard solution add the mobile phase to make exactly 10 mL. Confirm that the peak area of ibudilast obtained with 10 μ L of this solution is equivalent to 40 to 60% of that with 10 μ L of the standard solution.

System performance: To 5 mL of the sample solution add the mobile phase to make 50 mL. To 2 mL of this solution add the mobile phase to make 20 mL. When the procedure is run with 10 μ L of this solution under the above operating conditions, the number of theoretical plates and the symmetry factor of the peak of ibudilast are not less than 3500 and not more than 2.0, respectively.

System repeatability: When the test is repeated 6 times with 10 μ L of the standard solution under the above operating conditions, the relative standard deviation of the peak area of ibudilast is not more than 3.0%.

Loss on drying <2.41> Not more than 0.3% (1 g, in vacuum, 4 hours).

Residue on ignition <2.44> Not more than 0.1% (1 g).

Assay Weigh accurately about 0.2 g of Ibudilast, previously dried, dissolve in 50 mL of acetic anhydride, and titrate <2.50> with 0.1 mol/L perchloric acid VS (potentiometric titration). Perform a blank determination in the same manner, and make any necessary correction.

Each mL of 0.1 mol/L perchloric acid VS
= 23.03 mg of C₁₄H₁₈N₂O

Containers and storage Containers—Tight containers.

Ibuprofen

イブプロフェン

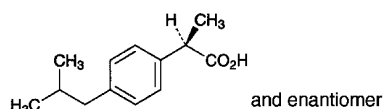

C₁₃H₁₈O₂: 206.28
(2*RS*)-2-[4-(2-Methylpropyl)phenyl]propanoic acid
[15687-27-1]

Ibuprofen, when dried, contains not less than 98.5% of ibuprofen (C₁₃H₁₈O₂).

Description Ibuprofen occurs as a white crystalline powder.

It is freely soluble in ethanol (95) and in acetone, and practically insoluble in water.

It dissolves in dilute sodium hydroxide TS.

Identification (1) Determine the absorption spectrum of a solution of Ibuprofen in dilute sodium hydroxide TS (3 in

20,000) as directed under Ultraviolet-visible Spectrophotometry <2.24>, and compare the spectrum with the Reference Spectrum: both spectra exhibit similar intensities of absorption at the same wavelengths.

(2) Determine the infrared absorption spectrum of Ibuprofen, previously dried, as directed in the potassium bromide disk method under Infrared Spectrophotometry <2.25>, and compare the spectrum with the Reference Spectrum: both spectra exhibit similar intensities of absorption at the same wave numbers.

Melting point <2.60> 75 – 77°C

Purity (1) Heavy metals <1.07>—Proceed with 3.0 g of Ibuprofen according to Method 2, and perform the test. Prepare the control solution with 3.0 mL of Standard Lead Solution (not more than 10 ppm).

(2) Arsenic <1.11>—Prepare the test solution with 1.0 g of Ibuprofen according to Method 3, and perform the test (not more than 2 ppm).

(3) Related substances—Dissolve 0.50 g of Ibuprofen in 5 mL of acetone, and use this solution as the sample solution. Pipet 1 mL of the sample solution, add acetone to make exactly 100 mL, and use this solution as the standard solution. Perform the test with these solutions as directed under Thin-layer Chromatography <2.03>. Spot 5 μ L each of the sample solution and standard solution on a plate of silica gel with fluorescent indicator for thin-layer chromatography. Develop the plate with a mixture of hexane, ethyl acetate and acetic acid (100) (15:5:1) to a distance of about 10 cm, and air-dry the plate. Examine the plate under ultraviolet light (main wavelength: 254 nm): the spots other than the principal spot obtained from the sample solution are not more intense than the spot from the standard solution.

Loss on drying <2.41> Not more than 0.5% (1 g, reduced pressure not exceeding 0.67 kPa, phosphorus (V) oxide, 4 hours).

Residue on ignition <2.44> Not more than 0.1% (1 g).

Assay Weigh accurately about 0.5 g of Ibuprofen, previously dried, dissolve in 50 mL of ethanol (95), and titrate <2.50> with 0.1 mol/L sodium hydroxide VS (indicator: 3 drops of phenolphthalein TS). Perform a blank determination in the same manner, and make any necessary correction.

Each mL of 0.1 mol/L sodium hydroxide VS
= 20.63 mg of C₁₃H₁₈O₂

Containers and storage Containers—Well-closed containers.

Ibuprofen Piconol

イブプロフェンピコノール

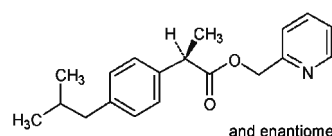

C₁₉H₂₃NO₂: 297.39
Pyridin-2-ylmethyl (2*RS*)-2-[4-(2-methylpropyl)phenyl]propanoate
[64622-45-3]

Ibuprofen Piconol contains not less than 98.5% and not more than 101.0% of ibuprofen piconol (C₁₉H₂₃NO₂), calculated on the anhydrous basis.

Description Ibuprofen Piconol occurs as a clear, colorless to pale yellow liquid. It is odorless or has a slight characteristic odor.

It is miscible with methanol, with ethanol (95), with acetone and with acetic acid (100).

It is practically insoluble in water.

It decomposes on exposure to light.

It shows no optical rotation.

Identification (1) Dissolve 10 mg of Ibuprofen Piconol in 250 mL of ethanol (95). Determine the absorption spectrum of this solution as directed under Ultraviolet-visible Spectrophotometry <2.24>, and compare the spectrum with the Reference Spectrum: both spectra exhibit similar intensities of absorption at the same wavelengths.

(2) Determine the infrared absorption spectrum of Ibuprofen Piconol as directed in the liquid film method under Infrared Spectrophotometry <2.25>, and compare the spectrum with the Reference Spectrum: both spectra exhibit similar intensities of absorption at the same wave numbers.

Refractive index <2.45> n_D^{20} : 1.529 – 1.532

Specific gravity <2.56> d_{20}^{20} : 1.046 – 1.050

Purity (1) Chloride <1.03>—Dissolve 0.5 g of Ibuprofen Piconol in 20 mL of acetone, add 6 mL of dilute nitric acid and water to make 50 mL. Perform the test using this solution as the test solution. Prepare the control solution as follows: to 0.30 mL of 0.01 mol/L hydrochloric acid VS add 20 mL of acetone, 6 mL of dilute nitric acid and water to make 50 mL (not more than 0.021%).

(2) **Sulfate** <1.14>—Dissolve 0.5 g of Ibuprofen Piconol in 20 mL of acetone, add 1 mL of dilute hydrochloric acid and water to make 50 mL. Perform the test using this solution as the test solution. Prepare the control solution as follows: to 0.40 mL of 0.005 mol/L sulfuric acid VS add 20 mL of acetone, 1 mL of dilute hydrochloric acid and water to make 50 mL (not more than 0.038%).

(3) **Heavy metals** <1.07>—Proceed with 4.0 g of Ibuprofen Piconol according to Method 2, and perform the test. Prepare the control solution with 2.0 mL of Standard Lead Solution (not more than 5 ppm).

(4) **Related substances**—Dissolve 0.10 g of Ibuprofen Piconol in 5 mL of methanol, and use this solution as the sample solution. Pipet 1 mL of the sample solution, add methanol to make exactly 200 mL, and use this solution as the standard solution. Perform the test with these solutions as directed under Thin-layer Chromatography <2.03>. Spot 10 μ L each of the sample solution and standard solution on a plate of silica gel for thin-layer chromatography. Develop the plate with a mixture of hexane, ethyl acetate, acetic acid (100) and methanol (30:10:2:1) to a distance of about 10 cm, and air-dry the plate. Spray evenly a solution of phosphomolybdic acid *n*-hydrate in ethanol (95) (1 in 10) on the plate, and heat the plate at 170°C for 10 minutes: the number of spots other than the dark brown principal spot obtained from the sample solution is two or less, and they are not more intense than the dark brown spot from the standard solution.

Water <2.48> Not more than 0.1% (5 g, volumetric titration, direct titration).

Residue on ignition <2.44> Not more than 0.1% (1 g).

Assay Weigh accurately about 0.6 g of Ibuprofen Piconol, dissolve in 50 mL of acetic acid (100), and titrate <2.50> with 0.1 mol/L perchloric acid VS (potentiometric titration). Perform a blank determination in the same manner, and make

any necessary correction.

Each mL of 0.1 mol/L perchloric acid VS
= 29.74 mg of C₁₉H₂₃NO₂

Containers and storage Containers—Tight containers.

Storage—Light-resistant.

Ibuprofen Piconol Cream

イブプロフェンピコノールクリーム

Ibuprofen Piconol Cream contains not less than 95.0% and not more than 105.0% of the labeled amount of ibuprofen piconol (C₁₉H₂₃NO₂; 297.39).

Method of preparation Prepare as directed under Creams, with Ibuprofen Piconol.

Identification To an amount of Ibuprofen Piconol Cream, equivalent to 50 mg of Ibuprofen Piconol, add 10 mL of methanol, warm in a water bath, mix well, filter after cooling, and use the filtrate as the sample solution. Separately, dissolve 50 mg of ibuprofen piconol in 10 mL of methanol, and use this solution as the standard solution. Perform the test with these solutions as directed under Thin-layer Chromatography <2.03>. Spot 10 μ L each of the sample solution and standard solution on a plate of silica gel with fluorescent indicator for thin-layer chromatography. Develop the plate with a mixture of hexane, ethyl acetate and acetic acid (100) (15:5:1) to a distance of about 13 cm, and air-dry the plate. Examine under ultraviolet light (main wavelength: 254 nm): the principal spot obtained from the sample solution and the spot from the standard solution show the same R_f value.

pH Being specified separately when the drug is granted approval based on the Law.

Assay Weigh accurately an amount of Ibuprofen Piconol Cream, equivalent to about 15 mg of ibuprofen piconol (C₁₉H₂₃NO₂), add 10 mL of tetrahydrofuran for liquid chromatography, shake vigorously, and add exactly 10 mL of the internal standard solution. Then, add methanol to make 30 mL, shake vigorously, filter through a membrane filter with a pore size not exceeding 0.45 μ m, and use the filtrate as the sample solution. Separately, weigh accurately about 0.15 g of ibuprofen piconol for assay (separately determine the water <2.48> in the same manner as Ibuprofen Piconol), and dissolve in tetrahydrofuran for liquid chromatography to make exactly 100 mL. Pipet 10 mL of this solution, add exactly 10 mL of the internal standard solution, add methanol to make 30 mL, and use this solution as the standard solution. Perform the test with 5 μ L each of the sample solution and standard solution as directed under Liquid Chromatography <2.01> according to the following conditions, and calculate the ratios, Q_T and Q_S, of the peak area of ibuprofen piconol to that of the internal standard.

Amount (mg) of ibuprofen piconol (C₁₉H₂₃NO₂)
= $M_S \times Q_T / Q_S \times 1/10$

M_S : Amount (mg) of ibuprofen piconol for assay taken, calculated on the anhydrous basis

Internal standard solution—A solution of triphenylmethane in methanol (1 in 200).

Operating conditions—

Detector: An ultraviolet absorption photometer (wavelength: 254 nm).

Column: A stainless steel column 4.6 mm in inside diame-

ter and 15 cm in length, packed with octadecylsilanized silica gel for liquid chromatography (5 μm in particle diameter).

Column temperature: A constant temperature of about 40°C.

Mobile phase: A mixture of methanol and acetic acid-sodium acetate buffer solution (pH 4.0) (3:1).

Flow rate: Adjust so that the retention time of ibuprofen piconol is about 6.5 minutes.

System suitability—

System performance: When the procedure is run with 5 μL of the standard solution under the above operating conditions, ibuprofen piconol and the internal standard are eluted in this order with the resolution between these peaks being not less than 8.

System repeatability: When the test is repeated 6 times with 5 μL of the standard solution under the above operating conditions, the relative standard deviation of the ratio of the peak area of ibuprofen piconol to that of the internal standard is not more than 1.0%.

Containers and storage Containers—Tight containers.

Storage—Light-resistant.

Ibuprofen Piconol Ointment

イブプロフェンピコノール軟膏

Ibuprofen Piconol Ointment contains not less than 95.0% and not more than 105.0% of the labeled amount of ibuprofen piconol ($\text{C}_{19}\text{H}_{23}\text{NO}_2$; 297.39).

Method of preparation Prepare as directed under Ointments, with Ibuprofen Piconol.

Identification To an amount of Ibuprofen Piconol Ointment, equivalent to 50 mg of Ibuprofen Piconol, add 10 mL of methanol, warm at 60°C in a water bath, mix well, and filter after cooling. Use the filtrate as the sample solution. Separately, dissolve 50 mg of ibuprofen piconol in 10 mL of methanol, and use this solution as the standard solution. Perform the test with these solutions as directed under Thin-layer Chromatography <2.03>. Spot 10 μL each of the sample solution and standard solution on a plate of silica gel with fluorescent indicator for thin-layer chromatography. Develop the plate with a mixture of hexane, ethyl acetate and acetic acid (100) (15:5:1) to a distance of about 13 cm, and air-dry the plate. Examine under ultraviolet light (main wavelength: 254 nm): the principal spot obtained from the sample solution and the spot from the standard solution show the same R_f value.

Assay Weigh accurately an amount of Ibuprofen Piconol Ointment, equivalent to about 15 mg of ibuprofen piconol ($\text{C}_{19}\text{H}_{23}\text{NO}_2$), add 10 mL of tetrahydrofuran for liquid chromatography, shake vigorously, and add exactly 10 mL of the internal standard solution. Then, add methanol to make 30 mL, shake vigorously, filter through a membrane filter with a pore size not exceeding 0.45 μm , and use the filtrate as the sample solution. Separately, weigh accurately about 0.15 g of ibuprofen piconol for assay (separately determine the water <2.48> in the same manner as Ibuprofen Piconol), and dissolve in tetrahydrofuran for liquid chromatography to make exactly 100 mL. Pipet 10 mL of this solution, add exactly 10 mL of the internal standard solution, add methanol to make exactly 30 mL, and use this solution as the standard solution. Perform the test with 5 μL each of the sample solution and standard solution as directed under Liquid Chroma-

tography <2.01> according to the following conditions, and calculate the ratios, Q_T and Q_S , of the peak area of ibuprofen piconol to that of the internal standard.

$$\begin{aligned} \text{Amount (mg) of ibuprofen piconol (C}_{19}\text{H}_{23}\text{NO}_2) \\ = M_S \times Q_T / Q_S \times 1/10 \end{aligned}$$

M_S : Amount (mg) of ibuprofen piconol for assay taken, calculated on the anhydrous basis

Internal standard solution—A solution of triphenylmethane in methanol (1 in 200).

Operating conditions—

Detector: An ultraviolet absorption photometer (wavelength: 254 nm).

Column: A stainless steel column 4.6 mm in inside diameter and 15 cm in length, packed with octadecylsilanized silica gel for liquid chromatography (5 μm in particle diameter).

Column temperature: A constant temperature of about 40°C.

Mobile phase: A mixture of methanol and acetic acid-sodium acetate buffer solution (pH 4.0) (3:1).

Flow rate: Adjust so that the retention time of ibuprofen piconol is about 6.5 minutes.

System suitability—

System performance: When the procedure is run with 5 μL of the standard solution under the above operating conditions, ibuprofen piconol and the internal standard are eluted in this order with the resolution between these peaks being not less than 8.

System repeatability: When the test is repeated 6 times with 5 μL of the standard solution under the above operating conditions, the relative standard deviation of the ratio of the peak area of ibuprofen piconol to that of the internal standard is not more than 1.0%.

Containers and storage Containers—Tight containers.

Storage—Light-resistant.

Ichthammol

イクタモール

Ichthammol, calculated on the dried basis, contains not less than 2.5% of ammonia (NH_3 ; 17.03), not more than 8.0% of ammonium sulfate [$(\text{NH}_4)_2\text{SO}_4$; 132.14], and not less than 10.0% of total sulfur (as S; 32.07).

Description Ichthammol is a red-brown to black-brown, viscous fluid. It has a characteristic odor.

It is miscible with water.

It is partially soluble in ethanol (95) and in diethyl ether.

Identification (1) To 4 mL of a solution of Ichthammol (3 in 10) add 8 mL of hydrochloric acid: a yellow-brown to blackish brown, oily or resinous mass is produced. Cool the mass with ice to solidify, and discard the water layer. Wash the residue with diethyl ether: a part of the mass dissolves but it does not dissolve completely even when it is washed until almost no color develops in the washing. Perform the following tests with this residue.

(i) To 0.1 g of the residue add 1 mL of a mixture of ethanol (95) and diethyl ether (1:1): it dissolves.

(ii) To 0.1 g of the residue add 2 mL of water: it dissolves. To 1 mL of this solution add 0.4 mL of hydrochloric acid: a yellow-brown to blackish brown oily or resinous substance is produced.

(iii) To 1 mL of the solution obtained in (ii) add 0.3 g of sodium chloride: a yellow-brown or blackish brown oily or resinous substance is produced.

(2) Boil 2 mL of a solution of Ichthammol (1 in 10) with 2 mL of sodium hydroxide TS: the gas evolved changes moistened red litmus paper to blue.

Loss on drying <2.41> Not more than 50% (0.5 g, 105°C, 6 hours).

Residue on ignition <2.44> Not more than 0.5% (1 g).

Assay (1) Ammonia—Weigh accurately about 5 g of Ichthammol, transfer to a Kjeldahl flask, and add 60 mL of water, 1 mL of 1-octanol and 4.5 mL of a solution of sodium hydroxide (2 in 5). Connect the flask to a distilling tube with a spray trap and a condenser, and immerse the lower outlet of the condenser in the receiver containing exactly 30 mL of 0.25 mol/L sulfuric acid VS. Distil slowly, collect about 50 mL of the distillate, and titrate <2.50> the excess sulfuric acid with 0.5 mol/L sodium hydroxide VS (indicator: 3 drops of methyl red TS). Perform a blank determination in the same manner.

$$\begin{aligned} \text{Each mL of 0.25 mol/L sulfuric acid VS} \\ = 8.515 \text{ mg of NH}_3 \end{aligned}$$

(2) **Ammonium sulfate**—Weigh accurately about 1 g of Ichthammol, add 25 mL of ethanol (95), stir thoroughly, and filter. Wash with a mixture of ethanol (95) and diethyl ether (1:1) until the washings are clear and colorless. Dry the filter paper and the residue in air, dissolve the residue in 200 mL of hot water acidified slightly with hydrochloric acid, and filter. Boil the filtrate, add 30 mL of barium chloride TS slowly, heat for 30 minutes on a water bath, and filter. Wash the precipitate with water, dry, and ignite to constant mass. Weigh the residue as barium sulfate (BaSO₄; 233.39).

$$\begin{aligned} \text{Amount (mg) of ammonium sulfate } [(NH_4)_2SO_4] \\ = \text{amount (mg) of barium sulfate (BaSO}_4) \times 0.566 \end{aligned}$$

(3) **Total sulfur**—Weigh accurately about 0.6 g of Ichthammol, transfer to a 200-mL Kjeldahl flask, and add 30 mL of water and 5 g of potassium chlorate, then add slowly 30 mL of nitric acid, and evaporate the mixture to about 5 mL. Transfer the residue to a 300-mL beaker with the aid of 25 mL of hydrochloric acid, and evaporate again to 5 mL. Add 100 mL of water, boil, filter, and wash with water. Heat the combined filtrate and washings to boil, add gradually 30 mL of barium chloride TS, heat the mixture on a water bath for 30 minutes, and filter. Wash the precipitate with water, dry, and ignite to constant mass. Weigh the residue as barium sulfate (BaSO₄).

$$\begin{aligned} \text{Amount (mg) of total sulfur (S)} \\ = \text{amount (mg) of barium sulfate (BaSO}_4) \times 0.13739 \end{aligned}$$

Containers and storage Containers—Tight containers.

Idarubicin Hydrochloride

イダルビシン塩酸塩

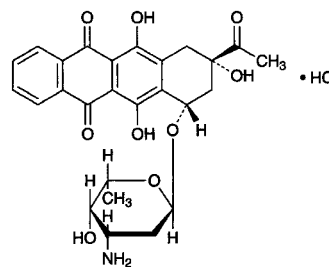

C₂₆H₂₇NO₉·HCl: 533.95

(2*S*,4*S*)-2-Acetyl-4-(3-amino-2,3,6-trideoxy- α -L-lyxo-hexopyranosyloxy)-2,5,12-trihydroxy-1,2,3,4-tetrahydrotetracene-6,11-dione monohydrochloride [57852-57-0]

Idarubicin Hydrochloride contains not less than 960 μ g (potency) and not more than 1030 μ g (potency) per mg, calculated on the anhydrous basis. The potency of Idarubicin Hydrochloride is expressed as mass (potency) of idarubicin hydrochloride (C₂₆H₂₇NO₉·HCl).

Description Idarubicin Hydrochloride occurs as a yellow-red powder.

It is sparingly soluble in methanol, slightly soluble in water and in ethanol (95), and practically insoluble in acetonitrile and in diethyl ether.

Identification (1) Determine the absorption spectra of a solution of Idarubicin Hydrochloride in methanol (1 in 100,000) as directed under Ultraviolet-visible Spectrophotometry <2.24>, and compare the spectrum with the Reference Spectrum or the spectrum of a solution of Idarubicin Hydrochloride RS prepared in the same manner as the sample solution: both spectra exhibit similar intensities of absorption at the same wavelengths.

(2) Determine the infrared absorption spectra of Idarubicin Hydrochloride and Idarubicin Hydrochloride RS as directed in the potassium bromide disk method under Infrared Spectrophotometry <2.25>, and compare these spectra: both spectra exhibit similar intensities of absorption at the same wave numbers.

(3) Dissolve 2 mg of Idarubicin Hydrochloride in 3 mL of water, and add 1 mL of dilute nitric acid and 3 drops of silver nitrate TS: a white turbidity is produced.

Optical rotation <2.49> $[\alpha]_D^{20}$: +188 – +201° (20 mg calculated on the anhydrous basis, methanol, 20 mL, 100 mm).

pH <2.54> Dissolve 10 mg of Idarubicin Hydrochloride in 10 mL of water: the pH of the solution is between 5.0 and 6.5.

Purity (1) Clarity and color of solution—Dissolve 10 mg of Idarubicin Hydrochloride in 10 mL of water: the solution is clear and yellow-red in color.

(2) **Silver**—Dissolve exactly 0.10 g of Idarubicin Hydrochloride in diluted nitric acid (1 in 200) to make exactly 20 mL, and use this solution as the sample solution. Separately, to exactly 5 mL of Standard Silver Solution for Atomic Absorption Spectrophotometry add diluted nitric acid (1 in 200) to make exactly 50 mL. Pipet a suitable amount of this solution, dilute exactly it with diluted nitric acid (1 in 200) so that each mL contains 0.05 μ g, 0.075 μ g, 0.1 μ g and 0.2 μ g of sil-

ver (Ag: 107.87), and use this solution as the standard solution. Perform the test with the sample solution and standard solution as directed under Atomic Absorption Spectrophotometry <2.23> according to the following conditions, and calculate the amount of silver in the sample solution using the calibration curve obtained with the absorbances of the standard solution: not more than 20 ppm.

Gas: Combustible gas—Acetylene.

Supporting gas—Air.

Lamp: Silver hollow-cathode lamp.

Wavelength: 328.1 nm.

(3) Related substances—Conduct this procedure using light-resistant vessels. Perform the test with 20 μ L of the sample solution obtained in the Assay as directed under Liquid Chromatography <2.01> according to the following conditions, determine each peak area by the automatic integration method, and calculate their amounts by the area percentage method: the amount of the peak other than idarubicin is not more than 1.0%, and the total amount of the peaks other than idarubicin is not more than 2.0%.

Operating conditions—

Detector, column, column temperature, mobile phase, and flow rate: Proceed as directed in the operating conditions in the Assay.

Time span of measurement: About 3.3 times as long as the retention time of idarubicin, beginning after the solvent peak.

System suitability—

Test for required detectability: To 1 mL of the sample solution add the mobile phase without sodium lauryl sulfate to make exactly 100 mL, and use this solution as the solution for system suitability test. Pipet 2 mL of the solution for system suitability test, and add the mobile phase without sodium lauryl sulfate to make exactly 20 mL. Confirm that the peak area of idarubicin obtained with 20 μ L of this solution is equivalent to 7 to 13% of that with 20 μ L of the solution for system suitability test.

System performance: When the procedure is run with 20 μ L of the solution for system suitability test under the above operating conditions, the number of theoretical plates and the symmetry factor of the peak of idarubicin are not less than 3000 and 0.8 to 1.2, respectively.

System repeatability: When the test is repeated 6 times with 20 μ L of the solution for system suitability test under the above operating conditions, the relative standard deviation of the peak area of idarubicin is not more than 2.0%.

Water <2.48> Not more than 5.0% (0.1 g, coulometric titration).

Residue on ignition <2.44> Not more than 0.5% (2 g).

Assay Weigh accurately an amount of Idarubicin Hydrochloride and Idarubicin Hydrochloride RS, equivalent to about 10 mg (potency), dissolve each in the mobile phase prepared without addition of sodium lauryl sulfate to make exactly 50 mL, and use these solutions as the sample solution and the standard solution, respectively. Perform the test with exactly 20 μ L each of the sample solution and standard solution as directed under Liquid Chromatography <2.01> according to the following conditions, and determine the peak areas, A_T and A_S , of idarubicin in each solution.

$$\begin{aligned} &\text{Amount } [\mu\text{g (potency)}] \text{ of idarubicin hydrochloride} \\ &(\text{C}_{26}\text{H}_{27}\text{NO}_9 \cdot \text{HCl}) \\ &= M_S \times A_T / A_S \times 1000 \end{aligned}$$

M_S : Amount [mg (potency)] of Idarubicin Hydrochloride RS taken

Operating conditions—

Detector: An ultraviolet absorption photometer (wavelength: 254 nm).

Column: A stainless steel column 3.9 mm in inside diameter and 15 cm in length, packed with octadecylsilanized silica gel for liquid chromatography (4 μ m in particle diameter).

Column temperature: A constant temperature of about 35°C.

Mobile phase: Dissolve 10.2 g of potassium dihydrogenphosphate in a suitable amount of water, add 1 mL of phosphoric acid and water to make 750 mL, and add 250 mL of tetrahydrofuran. To 500 mL of this solution add 0.72 g of sodium lauryl sulfate and 0.5 mL of *N,N*-dimethyl-*n*-octylamine, and adjust to pH 4 with 2 mol/L sodium hydroxide TS.

Flow rate: Adjust so that the retention time of idarubicin is about 15 minutes.

System suitability—

System performance: When the procedure is run with 20 μ L of the standard solution under the above operating conditions, the number of theoretical plates of the peak of idarubicin is not less than 3000.

System repeatability: When the test is repeated 6 times with 20 μ L of the standard solution under the above operating conditions, the relative standard deviation of the peak areas of idarubicin is not more than 2.0%.

Containers and storage Containers—Tight containers.

Idarubicin Hydrochloride for Injection

注射用イダルビシン塩酸塩

Idarubicin Hydrochloride for Injection is a preparation for injection, which is dissolved before use.

It contains not less than 90.0% and not more than 110.0% of the labeled amount of idarubicin hydrochloride ($\text{C}_{26}\text{H}_{27}\text{NO}_9 \cdot \text{HCl}$; 533.95).

Method of preparation Prepare as directed under Injections, with Idarubicin Hydrochloride.

Description Idarubicin Hydrochloride for Injection occurs as yellow-red masses.

Identification (1) Dissolve an amount of Idarubicin Hydrochloride for Injection, equivalent to 2 mg (potency) of Idarubicin Hydrochloride, in 5 mL of sodium hydroxide TS: the solution shows a blue-purple color.

(2) Dissolve an amount of Idarubicin Hydrochloride for Injection, equivalent to 1 mg (potency) of Idarubicin Hydrochloride, in 1 mL of water, and add methanol to make 100 mL. Determine the absorption spectrum of the solution as directed under Ultraviolet-visible Spectrophotometry <2.24>: it exhibits maxima between 250 nm and 254 nm, between 285 nm and 289 nm, between 480 nm and 484 nm, and between 510 nm and 520 nm.

pH <2.54> The pH of a solution prepared by dissolving an amount of Idarubicin Hydrochloride for Injection, equivalent to 5 mg (potency) of Idarubicin Hydrochloride, in 5 mL of water is between 5.0 and 7.0.

Purity Clarity and color of solution—Dissolve an amount of Idarubicin Hydrochloride for Injection, equivalent to 5 mg (potency) of Idarubicin Hydrochloride, in 5 mL of water: the solution is clear and yellow-red.

Water <2.48> Weigh accurately the mass of 1 Idoxuridine Hydrochloride for Injection, add 5 mL of methanol for water determination using a syringe, dissolve with thorough shaking, and perform the test with 4 mL of this solution as directed in the Volumetric titration (direct titration). Use 4 mL of methanol for water determination as the blank. Determine the mass of the content from the difference between the mass of 1 Idoxuridine Hydrochloride for Injection obtained above and the mass of its bottle and rubber stopper, which are weighed accurately after washing with water then with ethanol (95), drying at 105°C for 1 hour and allowing to cool to room temperature in a desiccator (not more than 4.0%).

Bacterial endotoxins <4.01> Less than 8.9 EU/mg (potency).

Uniformity of dosage units <6.02> Perform the test according to the following method: it meets the requirement of the Content uniformity test.

To 1 Idoxuridine Hydrochloride for Injection add the mobile phase prepared without addition of sodium lauryl sulfate to make exactly V mL so that each mL contains 0.2 mg (potency) of idoxuridine hydrochloride ($C_{26}H_{27}NO_9 \cdot HCl$), and use this solution as the sample solution. Separately, weigh accurately an amount of Idoxuridine Hydrochloride RS, equivalent to about 10 mg (potency), dissolve in the mobile phase without sodium lauryl sulfate to make exactly 50 mL, and use this solution as the standard solution. Proceed as directed in the Assay under Idoxuridine Hydrochloride.

$$\begin{aligned} & \text{Amount [mg (potency)] of idoxuridine hydrochloride} \\ & (C_{26}H_{27}NO_9 \cdot HCl) \\ & = M_S \times A_T/A_S \times V/50 \end{aligned}$$

$$M_S: \text{Amount [mg (potency)] of Idoxuridine Hydrochloride RS taken}$$

Foreign insoluble matter <6.06> Perform the test according to the Method 2: it meets the requirement.

Insoluble particulate matter <6.07> It meets the requirement.

Sterility <4.06> Perform the test according to the Membrane filtration method: it meets the requirement.

Assay Weigh accurately the mass of the contents of not less than 10 Idoxuridine Hydrochloride for Injection. Weigh accurately an amount of the content, equivalent to about 5 mg (potency), dissolve in the mobile phase prepared without addition of sodium lauryl sulfate to make exactly 25 mL, and use this solution as the sample solution. Separately, weigh accurately an amount of Idoxuridine Hydrochloride RS, equivalent to about 10 mg (potency), dissolve in the mobile phase without sodium lauryl sulfate to make exactly 50 mL, and use this solution as the standard solution. Proceed as directed in the Assay under Idoxuridine Hydrochloride.

$$\begin{aligned} & \text{Amount [mg (potency)] of idoxuridine hydrochloride} \\ & (C_{26}H_{27}NO_9 \cdot HCl) \\ & = M_S \times A_T/A_S \times 1/2 \end{aligned}$$

$$M_S: \text{Amount [mg (potency)] of Idoxuridine Hydrochloride RS taken}$$

Containers and storage Containers—Hermetic containers.

Idoxuridine

イドクスウリジン

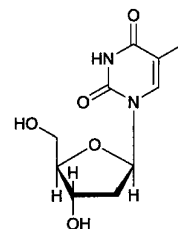

$C_9H_{11}IN_2O_5$; 354.10
5-Iodo-2'-deoxyuridine
[54-42-2]

Idoxuridine, when dried, contains not less than 98.0% of idoxuridine ($C_9H_{11}IN_2O_5$).

Description Idoxuridine occurs as colorless, crystals or a white, crystalline powder. It is odorless.

It is freely soluble in dimethylamide, slightly soluble in water, very slightly soluble in ethanol (95), and practically insoluble in diethyl ether.

It dissolves in sodium hydroxide TS.

Melting point: about 176°C (with decomposition).

Identification (1) Dissolve 0.01 g of Idoxuridine in 5 mL of water by warming, add 5 mL of diphenylamine-acetic acid TS, and heat for 5 minutes: a blue color develops.

(2) Heat 0.1 g of Idoxuridine: a purple gas evolves.

(3) Dissolve 2 mg of Idoxuridine in 50 mL of 0.01 mol/L sodium hydroxide. Determine the absorption spectrum of the solution as directed under Ultraviolet-visible Spectrophotometry <2.24>, and compare the spectrum with the Reference Spectrum or the spectrum of a solution of Idoxuridine RS prepared in the same manner as the sample solution: both spectra exhibit similar intensities of absorption at the same wavelengths.

Optical rotation <2.49> $[\alpha]_D^{20}$: +28 – +31° (after drying, 0.2 g, sodium hydroxide TS, 20 mL, 100 mm).

Purity (1) Clarity and color of solution—Dissolve 0.20 g of Idoxuridine in 5 mL of a solution of sodium hydroxide (1 in 200): the solution is clear and colorless.

(2) Heavy metals <1.07>—Proceed with 2.0 g of Idoxuridine according to Method 2, and perform the test. Prepare the control solution with 2.0 mL of Standard Lead Solution (not more than 10 ppm).

(3) Related substances—Dissolve 0.10 g of Idoxuridine in exactly 10 mL of a mixture of dilute ethanol and ammonia solution (28) (99:1), and use this solution as the sample solution. Perform the test with the sample solution as directed under Thin-layer Chromatography <2.03>. Spot 50 μ L of the sample solution on a plate of silica gel with fluorescent indicator for thin-layer chromatography. Develop the plate with a mixture of ethyl acetate and diluted 2-propanol (2 in 3) (4:1) to a distance of about 10 cm, and air-dry the plate. Then develop two-dimensionally at right angles to the first, and air-dry the plate. Examine under ultraviolet light (main wavelength: 254 nm): any spot other than the principal spot does not appear.

(4) Iodine and iodide—Dissolve 0.10 g of Idoxuridine in 20 mL of water and 5 mL of sodium hydroxide TS, and add immediately 5 mL of dilute sulfuric acid under ice-cooling. Allow to stand for 10 minutes with occasional shaking, and

filter. Transfer the filtrate into a Nessler tube, add 10 mL of chloroform and 3 drops of a solution of potassium iodate (1 in 100), shake for 30 seconds, and allow to stand: the chloroform layer has no more color than the following control solution.

Control solution: Weigh accurately 0.111 g of potassium iodide, and dissolve in water to make 1000 mL. To exactly 1 mL of this solution add 19 mL of water, 5 mL of sodium hydroxide TS and 5 mL of dilute sulfuric acid, mix, and filter. Transfer the filtrate to a Nessler tube, and proceed in the same manner.

Loss on drying <2.41> Not more than 0.5% (2 g, in vacuum, 60°C, 3 hours).

Residue on ignition <2.44> Not more than 0.3% (1 g).

Assay Weigh accurately about 0.7 g of Idoxuridine, previously dried, dissolve in 80 mL of *N,N*-dimethylformamide, and titrate <2.50> with 0.1 mol/L tetramethylammonium hydroxide VS until the color of the solution changes from yellow through yellow-green to blue (indicator: 5 drops of thymol blue-dimethylformamide TS). Perform a blank determination, and make any necessary correction in the same manner.

Each mL of 0.1 mol/L tetramethylammonium hydroxide VS
= 35.41 mg of $C_9H_{11}IN_2O_5$

Containers and storage Containers—Tight containers.
Storage—Light-resistant.

Idoxuridine Ophthalmic Solution

イドクスウリジン点眼液

Idoxuridine Ophthalmic Solution contains not less than 90.0% and not more than 110.0% of the labeled amount of idoxuridine ($C_9H_{11}IN_2O_5$; 354.10).

Method of preparation Prepare as directed under Ophthalmic Liquids and Solutions, with Idoxuridine.

Description Idoxuridine Ophthalmic Solution is a clear, colorless liquid.

Identification (1) To a volume of Idoxuridine Ophthalmic Solution, equivalent to 5 mg of Idoxuridine, add 5 mL of diphenylamine-acetic acid TS, and heat for 20 minutes: a light blue color develops.

(2) Place a volume of Idoxuridine Ophthalmic Solution, equivalent to 5 mg of Idoxuridine, in a porcelain crucible, add 0.1 g of anhydrous sodium carbonate, heat slowly, evaporate to dryness and ignite until the residue is incinerated. Dissolve the residue in 5 mL of water, acidify with hydrochloric acid, and add 2 to 3 drops of sodium nitrite TS: a yellow-brown color develops. Then add 2 to 3 drops of starch TS: a deep blue color develops.

(3) To a volume of Idoxuridine Ophthalmic Solution, equivalent to 2 mg of Idoxuridine, add 0.01 mol/L sodium hydroxide TS to make 50 mL. Determine the absorption spectrum of this solution as directed under Ultraviolet-visible Spectrophotometry <2.24>: it exhibits a maximum between 277 nm and 281 nm.

pH <2.54> 4.5 – 7.0

Purity 5-Iodouracil and 2'-deoxyuridine—To a volume of Idoxuridine Ophthalmic Solution, equivalent to 4.0 mg of

Idoxuridine, add water to make exactly 5 mL, and use this solution as the sample solution. Separately, dissolve 12.0 mg of 5-iodouracil for liquid chromatography and 4.0 mg of 2'-deoxyuridine for liquid chromatography in water to make exactly 200 mL. Measure exactly 5 mL of this solution, add water to make exactly 25 mL, and use this solution as the standard solution. Perform the test with exactly 10 μ L each of the sample solution and standard solution as directed under Liquid Chromatography <2.01> according to the following conditions, and determine the peak areas of 5-iodouracil and 2'-deoxyuridine: the peak areas of 5-iodouracil and 2'-deoxyuridine of the sample solution are not larger than the peak areas of 5-iodouracil and 2'-deoxyuridine of the standard solution.

Operating conditions—

Detector: An ultraviolet absorption photometer (wavelength: 254 nm).

Column: A stainless steel column 3.9 mm in inside diameter and 30 cm in length, packed with octadecylsilanized silica gel for liquid chromatography (10 μ m in particle diameter).

Column temperature: A constant temperature of about 25°C.

Mobile phase: A mixture of water and methanol (24:1).

Flow rate: Adjust so that the retention time of 2'-deoxyuridine is about 6 minutes.

System suitability—

System performance: When the procedure is run with 10 μ L of the standard solution under the above operating conditions, 2'-deoxyuridine and 5-iodouracil are eluted in this order with the resolution between these peaks being not less than 2.0.

System repeatability: When the test is repeated 6 times with 10 μ L of the standard solution under the above operating conditions, the relative standard deviation of the peak area of 2'-deoxyuridine is not more than 1.0%.

Foreign insoluble matter <6.11> It meets the requirement.

Insoluble particulate matter <6.08> It meets the requirement.

Sterility <4.06> Perform the test according to the Membrane filtration method: it meets the requirement.

Assay Measure exactly a volume of Idoxuridine Ophthalmic Solution, equivalent to 3 mg of idoxuridine ($C_9H_{11}IN_2O_5$), add exactly 2 mL of the internal standard solution, then add water to make 10 mL, and use this solution as the sample solution. Separately weigh accurately about 10 mg of Idoxuridine RS, previously dried at 60°C for 3 hours, dissolve in water to make exactly 10 mL. Measure exactly 3 mL of this solution, add exactly 2 mL of the internal standard solution, then add water to make 10 mL, and use this solution as the standard solution. Perform the test with 10 μ L each of the sample solution and standard solution as directed under Liquid Chromatography <2.01> according to the following conditions, and calculate the ratios, Q_T and Q_S , of the peak area of idoxuridine to that of the internal standard, respectively.

$$\begin{aligned} &\text{Amount (mg) of idoxuridine (C}_9\text{H}_{11}\text{IN}_2\text{O}_5\text{)} \\ &= M_S \times Q_T / Q_S \times 3 / 10 \end{aligned}$$

M_S : Amount (mg) of Idoxuridine RS taken

Internal standard solution—A solution of sulfathiazole in the mobile phase (1 in 4000).

Operating conditions—

Detector: An ultraviolet absorption photometer (wavelength: 254 nm).

Column: A stainless steel column 3.9 mm in inside diameter and 30 cm in length, packed with octadecylsilanized silica gel for liquid chromatography (10 μm in particle diameter).

Column temperature: A constant temperature of about 25°C.

Mobile phase: A mixture of water and methanol (87:13).

Flow rate: Adjust so that the retention time of idoxuridine is about 9 minutes.

System suitability—

System performance: When the procedure is run with 10 μL of the standard solution under the above operating conditions, idoxuridine and the internal standard are eluted in this order with the resolution between these peaks being not less than 2.0.

System repeatability: When the test is repeated 6 times with 10 μL of the standard solution under the above operating conditions, the relative standard deviation of the ratios of the peak area of idoxuridine to that of the internal standard is not more than 1.0%.

Containers and storage Containers—Tight containers.

Storage—Light-resistant, in a cold place, and avoid freezing.

Ifenprodil Tartrate

イフェンプロジル酒石酸塩

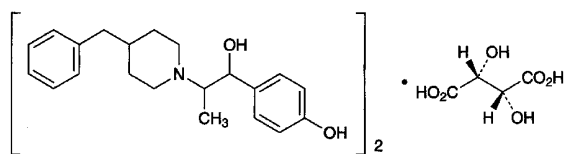

$(\text{C}_{21}\text{H}_{27}\text{NO}_2)_2 \cdot \text{C}_4\text{H}_6\text{O}_6$: 800.98

(1*R*,2*S*)-4-[2-(4-Benzylpiperidin-1-yl)-1-hydroxypropyl]phenol hemi-(2*R*,3*R*)-tartrate [23210-58-4]

Ifenprodil Tartrate contains not less than 98.5% of ifenprodil tartrate $[(\text{C}_{21}\text{H}_{27}\text{NO}_2)_2 \cdot \text{C}_4\text{H}_6\text{O}_6]$, calculated on the anhydrous basis.

Description Ifenprodil Tartrate occurs as a white crystalline powder. It is odorless.

It is freely soluble in acetic acid (100), soluble in ethanol (95), slightly soluble in water and in methanol, and practically insoluble in diethyl ether.

Optical rotation $[\alpha]_D^{20}$: +11 – +15° (1 g calculated on the anhydrous basis, ethanol (95), 20 mL, 100 mm).

Melting point: about 148°C (with decomposition).

Identification (1) Determine the absorption spectrum of a solution of Ifenprodil Tartrate in methanol (1 in 10,000) as directed under Ultraviolet-visible Spectrophotometry <2.24>, and compare the spectrum with the Reference Spectrum: both spectra exhibit similar intensities of absorption at the same wavelengths.

(2) Determine the infrared absorption spectrum of Ifenprodil Tartrate as directed in the potassium bromide disk method under Infrared Spectrophotometry <2.25>, and compare the spectrum with the Reference Spectrum: both spectra exhibit similar intensities of absorption at the same wave numbers.

(3) Dissolve 0.4 g of Ifenprodil Tartrate in 40 mL of water by warming. After cooling, add 0.5 mL of ammonia TS to this solution, extract with two 40-mL portions of chlo-

roform, and collect the water layer. Evaporate 30 mL of the water layer on a water bath to dryness, and after cooling, dissolve the residue in 6 mL of water: the solution responds to Qualitative Tests <1.09> for tartrate.

Purity (1) Heavy metals <1.07>—Proceed with 2.0 g of Ifenprodil Tartrate according to Method 2, and perform the test. Prepare the control solution with 2.0 mL of Standard Lead Solution (not more than 10 ppm).

(2) Related substances—Dissolve 0.30 g of Ifenprodil Tartrate in 10 mL of diluted ethanol (95) (3 in 4), and use this solution as the sample solution. Pipet 1 mL of the sample solution, add diluted ethanol (95) (3 in 4) to make exactly 200 mL, and use this solution as the standard solution. Perform the test with these solutions as directed under Thin-layer Chromatography <2.03>. Spot 10 μL each of the sample solution and standard solution on a plate of silica gel for thinlayer chromatography. Develop the plate with a mixture of ethyl acetate, hexane, 1-butanol and ammonia solution (28) (140:40:20:1) to a distance of about 10 cm, and air-dry the plate. Spray hydrogen hexachloroplatinate (IV)-potassium iodide TS evenly on the plate: the spots other than the principal spot obtained from the sample solution are not more intense than the spot from the standard solution.

Water <2.48> Not more than 4.0% (0.5 g, volumetric titration, direct titration).

Residue on ignition <2.44> Not more than 0.1% (1 g).

Assay Weigh accurately about 0.5 g of Ifenprodil Tartrate, dissolve in 50 mL of acetic acid (100), and titrate <2.50> with 0.1 mol/L perchloric acid VS (potentiometric titration). Perform a blank determination in the same manner, and make any necessary correction.

Each mL of 0.1 mol/L perchloric acid VS
= 40.05 mg of $(\text{C}_{21}\text{H}_{27}\text{NO}_2)_2 \cdot \text{C}_4\text{H}_6\text{O}_6$

Containers and storage Containers—Well-closed containers.

Storage—Light-resistant.

Ifenprodil Tartrate Fine Granules

イフェンプロジル酒石酸塩細粒

Ifenprodil Tartrate Fine Granules contain not less than 95.0% and not more than 105.0% of the labeled amount of ifenprodil tartrate $[(\text{C}_{21}\text{H}_{27}\text{NO}_2)_2 \cdot \text{C}_4\text{H}_6\text{O}_6$: 800.98].

Method of preparation Prepare as directed under Granules, with Ifenprodil Tartrate.

Identification Determine the absorption spectrum of the sample solution obtained in the Assay as directed under Ultraviolet-visible Spectrophotometry <2.24>: it exhibits a maximum between 274 nm and 278 nm.

Uniformity of dosage units <6.02> Perform the test according to the following method: Ifenprodil Tartrate Fine Granules in single-dose packages meet the requirement of the Content uniformity test.

To the total amount of the content of 1 package of Ifenprodil Tartrate Fine Granules, add 10 mL of water and a suitable amount of a mixture of ethanol (99.5) and water (3:1), shake thoroughly, and add a mixture of ethanol (99.5) and water (3:1) to make exactly *V* mL so that each mL contains about 0.1 mg of ifenprodil tartrate

$[(C_{21}H_{27}NO_2)_2 \cdot C_4H_6O_6]$. Filter through a membrane filter with a pore size not exceeding $0.45 \mu\text{m}$, discard the first 10 mL of the filtrate, and use the subsequent filtrate as the sample solution. Then, proceed as directed in the Assay.

$$\text{Amount (mg) of ifenprodil tartrate } [(C_{21}H_{27}NO_2)_2 \cdot C_4H_6O_6] \\ = M_S \times A_T/A_S \times V/200$$

M_S : Amount (mg) of ifenprodil tartrate for assay taken, calculated on the anhydrous basis

Dissolution Being specified separately when the drug is granted approval based on the Law.

Assay Powder Ifenprodil Tartrate Fine Granules, and weigh accurately a portion of the powder, equivalent to about 10 mg of ifenprodil tartrate $[(C_{21}H_{27}NO_2)_2 \cdot C_4H_6O_6]$, add 5 mL of water and a suitable amount of a mixture of ethanol (99.5) and water (3:1), shake thoroughly, and add a mixture of ethanol (99.5) and water (3:1) to make exactly 100 mL. Filter through a membrane filter with a pore size not exceeding $0.45 \mu\text{m}$. Discard the first 10 mL of the filtrate, and use the subsequent filtrate as the sample solution. Separately, weigh accurately about 20 mg of ifenprodil tartrate for assay (separately determine the water <2.48> in the same manner as Ifenprodil Tartrate), add 10 mL of water and a mixture of ethanol (99.5) and water (3:1) to make exactly 200 mL, and use this solution as the standard solution. Perform the test with exactly 20 μL each of the sample solution and standard solution as directed under Liquid Chromatography <2.01> according to the following conditions, and determine the peak areas, A_T and A_S , of ifenprodil in each solution.

$$\text{Amount (mg) of ifenprodil tartrate } [(C_{21}H_{27}NO_2)_2 \cdot C_4H_6O_6] \\ = M_S \times A_T/A_S \times 1/2$$

M_S : Amount (mg) of ifenprodil tartrate for assay taken, calculated on the anhydrous basis

Operating conditions—

Detector: An ultraviolet absorption photometer (wavelength: 224 nm).

Column: A stainless steel column 4.6 mm in inside diameter and 15 cm in length, packed with octadecylsilanized silica gel for liquid chromatography ($5 \mu\text{m}$ in particle diameter).

Column temperature: A constant temperature of about 25°C .

Mobile phase: Dissolve 6.8 g of potassium dihydrogen phosphate in 900 mL of water, adjust to pH 6.5 with potassium hydroxide TS, and add water to make 1000 mL. To 420 mL of this solution add 320 mL of methanol for liquid chromatography and 260 mL of acetonitrile for liquid chromatography.

Flow rate: Adjust so that the retention time of ifenprodil is about 10 minutes.

System suitability—

System performance: When the procedure is run with 20 μL of the standard solution under the above operating conditions, the number of theoretical plates and the symmetry factor of the peak of ifenprodil are not less than 3000 and not more than 2.0, respectively.

System repeatability: When the test is repeated 6 times with 20 μL of the standard solution under the above operating conditions, the relative standard deviation of the peak area of ifenprodil is not more than 1.0%.

Containers and storage Containers—Tight containers.

Storage—Light-resistant.

Ifenprodil Tartrate Tablets

イフェンプロジル酒石酸塩錠

Ifenprodil Tartrate Tablets contain not less than 95.0% and not more than 105.0% of the labeled amount of ifenprodil tartrate $[(C_{21}H_{27}NO_2)_2 \cdot C_4H_6O_6]$: 800.98].

Method of preparation Prepare as directed under Tablets, with Ifenprodil Tartrate.

Identification Determine the absorption spectrum of the sample solution obtained in the Assay as directed under Ultraviolet-visible Spectrophotometry <2.24>: it exhibits a maximum between 274 nm and 278 nm.

Uniformity of dosage units <6.02> Perform the test according to the following method: it meets the requirement of the Content uniformity test.

To 1 tablet of Ifenprodil Tartrate Tablets, add $V/20$ mL of water, and shake until the tablet is completely disintegrated. Then, add $7V/10$ mL of a mixture of ethanol (99.5) and water (3:1), shake thoroughly, and add a mixture of ethanol (99.5) and water (3:1) to make exactly V mL so that each mL contains about 0.1 mg of ifenprodil tartrate $[(C_{21}H_{27}NO_2)_2 \cdot C_4H_6O_6]$. Filter through a membrane filter with a pore size not exceeding $0.45 \mu\text{m}$, discard the first 10 mL of the filtrate, and use the subsequent filtrate as the sample solution. Then, proceed as directed in the Assay.

$$\text{Amount (mg) of ifenprodil tartrate } [(C_{21}H_{27}NO_2)_2 \cdot C_4H_6O_6] \\ = M_S \times A_T/A_S \times V/200$$

M_S : Amount (mg) of ifenprodil tartrate for assay taken, calculated on the anhydrous basis

Dissolution Being specified separately when the drug is granted approval based on the Law.

Assay Weigh accurately the mass of not less than 20 Ifenprodil Tartrate Tablets, and powder. Weigh accurately a portion of the powder, equivalent to about 10 mg of ifenprodil tartrate $[(C_{21}H_{27}NO_2)_2 \cdot C_4H_6O_6]$, add 5 mL of water and a suitable amount of a mixture of ethanol (99.5) and water (3:1), shake thoroughly, and add a mixture of ethanol (99.5) and water (3:1) to make exactly 100 mL. Filter through a membrane filter with a pore size not exceeding $0.45 \mu\text{m}$. Discard the first 10 mL of the filtrate, and use the subsequent filtrate as the sample solution. Separately, weigh accurately about 20 mg of ifenprodil tartrate for assay (separately determine the water <2.48> in the same manner as Ifenprodil Tartrate), add 10 mL of water and a mixture of ethanol (99.5) and water (3:1) to make exactly 200 mL, and use this solution as the standard solution. Perform the test with 20 μL each of the sample solution and standard solution as directed under Liquid Chromatography <2.01> according to the following conditions, and determine the peak areas, A_T and A_S , of ifenprodil tartrate in each solution.

$$\text{Amount (mg) of ifenprodil tartrate } [(C_{21}H_{27}NO_2)_2 \cdot C_4H_6O_6] \\ = M_S \times A_T/A_S \times 1/2$$

M_S : Amount (mg) of ifenprodil tartrate for assay taken, calculated on the anhydrous basis

Operating conditions—

Detector: An ultraviolet absorption photometer (wavelength: 224 nm).

Column: A stainless steel column 4.6 mm in inside diame-

ter and 15 cm in length, packed with octadecylsilanized silica gel for liquid chromatography (5 μm in particle diameter).

Column temperature: A constant temperature of about 25°C.

Mobile phase: Dissolve 6.8 g of potassium dihydrogen phosphate in 900 mL of water, adjust to pH 6.5 with potassium hydroxide TS, and add water to make 1000 mL. To 420 mL of this solution, add 320 mL of methanol for liquid chromatography and 260 mL of acetonitrile for liquid chromatography.

Flow rate: Adjust so that the retention time of ifenprodil is about 10 minutes.

System suitability—

System performance: When the procedure is run with 20 μL of the standard solution under the above operating conditions, the number of theoretical plates and the symmetry factor of the peak of ifenprodil are not less than 3000 and not more than 2.0, respectively.

System repeatability: When the test is repeated 6 times with 20 μL of the standard solution under the above operating conditions, the relative standard deviation of the peak area of ifenprodil is not more than 1.0%.

Containers and storage containers—Tight containers.

Imidapril Hydrochloride

イミダプリル塩酸塩

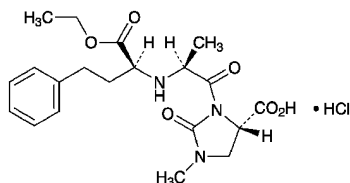

$\text{C}_{20}\text{H}_{27}\text{N}_3\text{O}_6 \cdot \text{HCl}$: 441.91

(4*S*)-3-[(2*S*)-2-[(1*S*)-1-Ethoxycarbonyl-3-phenylpropylamino]propanoyl]-1-methyl-2-oxoimidazolidine-4-carboxylic acid monohydrochloride

[89396-94-1]

Imidapril Hydrochloride, when dried, contains not less than 98.5% and not more than 101.0% of imidapril hydrochloride ($\text{C}_{20}\text{H}_{27}\text{N}_3\text{O}_6 \cdot \text{HCl}$).

Description Imidapril Hydrochloride occurs as white crystals.

It is freely soluble in methanol, soluble in water, and sparingly soluble in ethanol (99.5).

Dissolve 1.0 g of Imidapril Hydrochloride in 100 mL of water: the pH of the solution is about 2.

Melting point: about 203°C (with decomposition).

Identification (1) To 3 mL of a solution of Imidapril Hydrochloride (1 in 50) add 5 drops of Reinecke salt TS: a light red precipitate is formed.

(2) Determine the infrared absorption spectrum of Imidapril Hydrochloride as directed in the potassium chloride disk method under Infrared Spectrophotometry <2.25>, and compare the spectrum with the Reference Spectrum: both spectra exhibit similar intensities of absorption at the same wave numbers.

(3) A solution of Imidapril Hydrochloride (1 in 50) responds to Qualitative Tests <1.09> for chloride.

Optical rotation <2.49> $[\alpha]_D^{20}$: $-65.0 - -69.0^\circ$ (after dry-

ing, 0.1 g, methanol, 10 mL, 100 mm).

Purity (1) Heavy metals <1.07>—Proceed with 2.0 g of Imidapril Hydrochloride according to Method 4, and perform the test. Prepare the control solution with 2.0 mL of Standard Lead Solution (not more than 10 ppm).

(2) Related substances—Dissolve 25 mg of Imidapril Hydrochloride in 50 mL of the mobile phase, and use this solution as the sample solution. Pipet 1 mL of the sample solution, add the mobile phase to make exactly 100 mL, and use this solution as the standard solution. Perform the test with exactly 20 μL each of the sample solution and standard solution as directed under Liquid Chromatography <2.01> according to the following conditions. Determine each peak area of both solutions by the automatic integration method: the area of the peak having the relative retention time of about 0.45 to imidapril, obtained from the sample solution, is not larger than 2/5 times the peak area of imidapril from the standard solution, and the area of each peak other than imidapril and the peak mentioned above from the sample solution is not larger than 1/5 times the peak area of imidapril from the standard solution. Furthermore, the total area of the peaks other than imidapril from the sample solution is not larger than 1/2 times the peak area of imidapril from the standard solution.

Operating conditions—

Detector: An ultraviolet absorption photometer (wavelength: 215 nm).

Column: A stainless steel column 4.6 mm in inside diameter and 15 cm in length, packed with octylsilanized silica gel for liquid chromatography (5 μm in particle diameter).

Column temperature: A constant temperature of about 40°C.

Mobile phase: Dissolve 1.36 g of potassium dihydrogen phosphate in 1000 mL of water, and adjust the pH to 2.7 with phosphoric acid. To 600 mL of this solution add 400 mL of methanol.

Flow rate: Adjust so that the retention time of imidapril is about 8 minutes.

Time span of measurement: About 2 times as long as the retention time of imidapril, beginning after the solvent peak.

System suitability—

Test for required detectability: Pipet 2 mL of the standard solution, and add the mobile phase to make exactly 20 mL. Confirm that the peak area of imidapril obtained with 20 μL of this solution is equivalent to 7 to 13% of that with 20 μL of the standard solution.

System performance: When the procedure is run with 20 μL of the standard solution under the above operating conditions, the number of theoretical plates and the symmetry factor of the peak of imidapril are not less than 5000 and not more than 1.5, respectively.

System repeatability: When the test is repeated 6 times with 20 μL of the standard solution under the above operating conditions, the relative standard deviation of the peak area of imidapril is not more than 2.0%.

Loss on drying <2.41> Not more than 0.5% (1 g, 105°C, 3 hours).

Residue on ignition <2.44> Not more than 0.1% (1 g).

Assay Weigh accurately about 0.4 g of Imidapril Hydrochloride, previously dried, dissolve in 70 mL of water, and titrate <2.50> with 0.1 mol/L sodium hydroxide VS from the first equivalent point to the second equivalent point (potentiometric titration).

Each mL of 0.1 mol/L sodium hydroxide VS
= 44.19 mg of $C_{20}H_{27}N_3O_6 \cdot HCl$

Containers and storage Containers—Well-closed containers.

Imidapril Hydrochloride Tablets

イミダプリル塩酸塩錠

Imidapril Hydrochloride Tablets contain not less than 95.0% and not more than 105.0% of the labeled amount of Imidapril Hydrochloride ($C_{20}H_{27}N_3O_6 \cdot HCl$; 441.91).

Method of preparation Prepare as directed under Tablets, with Imidapril Hydrochloride.

Identification Weigh accurately an amount of powdered Imidapril Hydrochloride Tablets, equivalent to 25 mg of Imidapril Hydrochloride, add 5 mL of ethanol (99.5), shake well, filter, and use the filtrate as the sample solution. Separately, dissolve 25 mg of imidapril hydrochloride in 5 mL of ethanol (99.5), and use this solution as the standard solution. Perform the test with these solutions as directed under Thin-layer Chromatography <2.03>. Spot 10 μ L each of the sample solution and standard solution on a plate of silica gel with fluorescent indicator for thin-layer chromatography. Develop the plate with a mixture of 1-butanol, ethyl acetate, water, ethanol (99.5) and acetic acid (100) (16:16:7:2:2) to a distance of about 13 cm, and air-dry the plate. Examine under ultraviolet light (main wavelength: 254 nm): the principal spot obtained from the sample solution has the same R_f value as the spot from the standard solution.

Purity Related substances—To a quantity of powdered Imidapril Hydrochloride Tablets, equivalent to 25 mg of Imidapril Hydrochloride, add 40 mL of diluted methanol (2 in 5), shake vigorously for 10 minutes, add diluted ethanol (2 in 5) to make 50 mL, and filter through a membrane filter with a pore size not exceeding 0.45 μ m. Discard the first 2 mL of the filtrate, and use the subsequent filtrate as the sample solution. Pipet 1 mL of the sample solution, add diluted methanol (2 in 5) to make exactly 100 mL, and use this solution as the standard solution. Perform the test with exactly 20 μ L each of the sample solution and standard solution as directed under Liquid Chromatography <2.01> according to the following conditions. Determine each peak area of both solutions by the automatic integration method: the area of the peak having the relative retention time of about 0.45 to imidapril, obtained from the sample solution, is not larger than the peak area of imidapril from the standard solution, the area of the peak having the relative retention time of about 0.8 to imidapril from the sample solution is not larger than 7/10 times the peak area of imidapril from the standard solution, and the area of each peak other than imidapril and the peaks mentioned above from the sample solution is not larger than 3/10 times the peak area of imidapril from the standard solution. Furthermore, the total area of the peaks other than imidapril from the sample solution is not larger than 1.5 times the peak area of imidapril from the standard solution.

Operating conditions—

Detector, column, column temperature, mobile phase and flow rate: Proceed as directed in the operating conditions in the Assay.

Time span of measurement: About 2 times as long as the

retention time of imidapril, beginning after the solvent peak.

System suitability—

Test for required detectability: Pipet 2 mL of the standard solution, and add diluted methanol (2 in 5) to make exactly 20 mL. Confirm that the peak area of imidapril obtained with 20 μ L of this solution is equivalent to 7 to 13% of that with 20 μ L of the standard solution.

System performance: When the procedure is run with 20 μ L of the standard solution under the above operating conditions, the number of theoretical plates and the symmetry factor of the peak of imidapril are not less than 5000 and not more than 1.5, respectively.

System repeatability: When the test is repeated 6 times with 20 μ L of the standard solution under the above operating conditions, the relative standard deviation of the peak area of imidapril is not more than 2.0%.

Uniformity of dosage units <6.02> Perform the test according to the following method: it meets the requirement of the Content uniformity test.

To 1 tablet of Imidapril Hydrochloride Tablets add 2V/5 mL of water, shake vigorously for 10 minutes, add diluted methanol (2 in 3) to make exactly V mL so that each mL contains about 0.1 mg of imidapril hydrochloride ($C_{20}H_{27}N_3O_6 \cdot HCl$), filter through a membrane filter with a pore size not exceeding 0.45 μ m. Discard the first 2 mL of the filtrate, and use the subsequent filtrate as the sample solution. Separately, weigh accurately about 10 mg of imidapril for assay, previously dried at 105°C for 3 hours, dissolve in diluted methanol (2 in 5) to make exactly 100 mL, and use this solution as the standard solution. Perform the test with exactly 20 μ L each of the sample solution and standard solution as directed under Liquid Chromatography <2.01> according to the following conditions, and determine the peak areas, A_T and A_S , of imidapril in each solution.

Amount (mg) of imidapril hydrochloride ($C_{20}H_{27}N_3O_6 \cdot HCl$)
= $M_S \times A_T / A_S \times V / 100$

M_S : Amount (mg) of imidapril hydrochloride for assay taken

Operating conditions—

Proceed as directed in the operating conditions in the Assay.

System suitability—

System performance: When the procedure is run with 20 μ L of the standard solution under the above operating conditions, the number of theoretical plates and the symmetry factor of the peak of imidapril are not less than 5000 and not more than 1.5, respectively.

System repeatability: When the test is repeated 6 times with 20 μ L of the standard solution under the above operating conditions, the relative standard deviation of the peak area of imidapril is not more than 1.0%.

Dissolution <6.10> When the test is performed at 50 revolutions per minute according to the Paddle method, using 900 mL of water as the dissolution medium, the dissolution rate in 45 minutes of Imidapril Hydrochloride Tablets is not less than 85%.

Start the test with 1 tablet of Imidapril Hydrochloride Tablets, withdraw not less than 20 mL of the medium at the specified minute after starting the test, and filter through a membrane filter with a pore size not exceeding 0.45 μ m. Discard not less than 10 mL of the first filtrate, pipet V mL of the subsequent filtrate, add water to make exactly V' mL so that each mL contains about 2.8 μ g of imidapril hydrochloride ($C_{20}H_{27}N_3O_6 \cdot HCl$), and use this solution as the sample

solution. Separately, weigh accurately about 28 mg of imidapril hydrochloride for assay, previously dried at 105°C for 3 hours, and dissolve in water to make exactly 100 mL. Pipet 2 mL of this solution, add water to make exactly 200 mL, and use this solution as the standard solution. Perform the test with exactly 50 μ L each of the sample solution and standard solution as directed under Liquid Chromatography <2.01> according to the following conditions, and determine the peak areas, A_T and A_S , of imidapril in each solution.

Dissolution rate (%) with respect to the labeled amount of imidapril hydrochloride ($C_{20}H_{27}N_3O_6 \cdot HCl$)

$$= M_S \times A_T / A_S \times V' / V \times 1 / C \times 9$$

M_S : Amount (mg) of imidapril hydrochloride for assay taken

C : Labeled amount (mg) of imidapril hydrochloride ($C_{20}H_{27}N_3O_6 \cdot HCl$) in 1 tablet

Operating conditions—

Proceed as directed in the operating conditions in the Assay.

System suitability—

System performance: When the procedure is run with 50 μ L of the standard solution under the above operating conditions, the number of theoretical plates and the symmetry factor of the peak of imidapril are not less than 5000 and not more than 1.5, respectively.

System repeatability: When the test is repeated 6 times with 50 μ L of the standard solution under the above operating conditions, the relative standard deviation of the peak area of imidapril is not more than 2.0%.

Assay Weigh accurately not less than 20 Imidapril Hydrochloride Tablets, and powder. Weigh accurately a portion of the powder, equivalent to about 20 mg of imidapril hydrochloride ($C_{20}H_{27}N_3O_6 \cdot HCl$), add 30 mL of diluted methanol (2 in 5) and exactly 5 mL of the internal standard solution, shake vigorously for 10 minutes, add diluted methanol (2 in 5) to make 50 mL, and filter through a membrane filter with a pore size not exceeding 0.45 μ m. Discard the first 2 mL of the filtrate, pipet 5 mL of the subsequent filtrate, add diluted methanol (2 in 5) to make 20 mL, and use this solution as the sample solution. Separately, weigh accurately about 20 mg of imidapril hydrochloride for assay, previously dried at 105°C for 3 hours, dissolve in exactly 5 mL of the internal standard solution, add diluted methanol (2 in 5) to make 50 mL. Pipet 5 mL of this solution, add diluted methanol (2 in 5) to make 20 mL, and use this solution as the standard solution. Perform the test with 20 μ L each of the sample solution and standard solution as directed under Liquid Chromatography <2.01> according to the following conditions, and calculate the ratios, Q_T and Q_S , of the peak area of imidapril to that of the internal standard.

Amount (mg) of imidapril hydrochloride ($C_{20}H_{27}N_3O_6 \cdot HCl$)

$$= M_S \times Q_T / Q_S$$

M_S : Amount (mg) of imidapril hydrochloride for assay taken

Internal standard solution—A solution of ethyl parahydroxybenzoate in diluted methanol (2 in 5) (1 in 500).

Operating conditions—

Detector: An ultraviolet absorption photometer (wavelength: 215 nm).

Column: A stainless steel column 4.6 mm in inside diameter and 15 cm in length, packed with octylsilanized silica gel for liquid chromatography (5 μ m in particle diameter).

Column temperature: A constant temperature of about

40°C.

Mobile phase: Dissolve 1.36 g of potassium dihydrogen phosphate in 1000 mL of water, and adjust the pH to 2.7 with phosphoric acid. To 600 mL of this solution add 400 mL of methanol.

Flow rate: Adjust so that the retention time of imidapril is about 8 minutes.

System suitability—

System performance: When the procedure is run with 20 μ L of the standard solution under the above operating conditions, imidapril and the internal standard are eluted in this order with the resolution between these peaks being not less than 4.

System repeatability: When the test is repeated 6 times with 20 μ L of the standard solution under the above operating conditions, the relative standard deviation of the ratio of the peak area of imidapril to that of the internal standard is not more than 1.0%.

Containers and storage Containers—Tight containers.

Imipenem Hydrate

イミペネム水和物

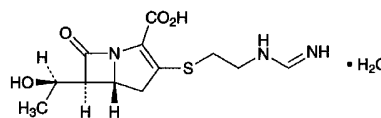

$C_{12}H_{17}N_3O_4S \cdot H_2O$: 317.36

(5*R*,6*S*)-3-[2-(Formimidoylamino)ethylsulfanyl]-6-[(1*R*)-1-hydroxyethyl]-7-oxo-1-azabicyclo[3.2.0]hept-2-ene-2-carboxylic acid monohydrate
[74431-23-5]

Imipenem Hydrate contains not less than 980 μ g (potency) and not more than 1010 μ g (potency) per mg, calculated on the anhydrous basis. The potency of Imipenem Hydrate is expressed as mass (potency) of imipenem ($C_{12}H_{17}N_3O_4S$: 299.35).

Description Imipenem Hydrate occurs as a white to light yellow crystalline powder.

It is sparingly soluble in water, and practically insoluble in ethanol (99.5).

Identification (1) Determine the absorption spectrum of a solution of Imipenem Hydrate in 0.1 mol/L 3-(*N*-morpholino)propanesulfonic acid buffer solution (pH 7.0) (1 in 50,000) as directed under Ultraviolet-visible Spectrophotometry <2.24>, and compare the spectrum with the Reference Spectrum or the spectrum of a solution of Imipenem RS prepared in the same manner as the sample solution: both spectra exhibit similar intensities of absorption at the same wavelengths.

(2) Determine the infrared absorption spectrum of Imipenem Hydrate as directed in the potassium bromide disk method under Infrared Spectrophotometry <2.25>, and compare the spectrum with the Reference Spectrum or the spectrum of Imipenem RS: both spectra exhibit similar intensities of absorption at the same wave numbers.

Optical rotation <2.49> $[\alpha]_D^{20}$: +89 – +94° (50 mg calculated on the anhydrous basis, 0.1 mol/L 3-(*N*-morpholino)propanesulfonic acid buffer solution (pH 7.0), 10 mL, 100 mm).

pH <2.54> The pH of a solution obtained by dissolving 1.0 g of Imipenem Hydrate in 200 mL of water is between 4.5 and 7.0.

Purity (1) Heavy metals <1.07>—Proceed with 1.0 g of Imipenem Hydrate according to Method 2, and perform the test. Prepare the control solution with 2.0 mL of Standard Lead Solution (not more than 20 ppm).

(2) Arsenic <1.11>—Put 2.0 g of Imipenem Hydrate in a crucible, add 5 mL of nitric acid and 1 mL of sulfuric acid, and heat carefully until white fumes evolve. After cooling, add 2 mL of nitric acid, heat, and repeat this procedure once more. Then add 2 mL of hydrogen peroxide (30), heat, and repeat this procedure several times until the color of the solution changes to colorless to pale yellow. After cooling, heat again until white fumes evolve. After cooling, add water to make 5 mL, and perform the test with this solution as the test solution (not more than 1 ppm).

(3) Related substances—Dissolve 50 mg of Imipenem Hydrate in 50 mL of 0.1 mol/L 3-(*N*-morpholino)propanesulfonic acid buffer solution (pH 7.0) and use this solution as the sample solution. Pipet 1 mL of the sample solution, add 0.1 mol/L 3-(*N*-morpholino)propanesulfonic acid buffer solution (pH 7.0) to make exactly 100 mL, and use this solution as the standard solution. Perform the test with exactly 10 μ L each of the sample solution and standard solution as directed under Liquid Chromatography <2.01> according to the following conditions, and determine each peak area by the automatic integration method: the peak area of thienamycin, having the relative retention time of about 0.8 to imipenem, obtained from the sample solution is not larger than 1.4 times the peak area of imipenem from the standard solution, the area of the peak other than imipenem and thienamycin from the sample solution is not larger than 1/3 times the peak area of imipenem from the standard solution, and the total area of the peaks other than imipenem and thienamycin from the sample solution is not larger than the peak area of imipenem from the standard solution.

Operating conditions—

Detector, column, column temperature, mobile phase, and flow rate: Proceed as directed in the operating conditions in the Assay.

Time span of measurement: About 2 times as long as the retention time of imipenem.

System suitability—

System performance: Proceed as directed in the system suitability in the Assay.

Test for required detectability: Measure exactly 5 mL of the standard solution, add 0.1 mol/L 3-(*N*-morpholino)propanesulfonic acid buffer solution (pH 7.0) to make exactly 50 mL. Confirm that the peak area of imipenem obtained with 10 μ L of this solution is equivalent to 7 to 13% of that with the standard solution.

System repeatability: When the test is repeated 6 times with 10 μ L of the standard solution under the above operating conditions, the relative standard deviation of the peak area of imipenem is not more than 2.0%.

Water <2.48> Not less than 5.0% and not more than 8.0% (20 mg, coulometric titration, water evaporation temperature: 140°C).

Residue on ignition <2.44> Not more than 0.2% (1 g).

Assay Perform the procedure within 30 minutes after preparation of the sample solution and standard solution. Weigh accurately an amount of Imipenem Hydrate and Imipenem RS, equivalent to about 50 mg (potency), dissolve each in 0.1 mol/L 3-(*N*-morpholino)propanesulfonic acid

buffer solution (pH 7.0) to make exactly 50 mL, and use these solutions as the sample solution and standard solution. Perform the test with exactly 10 μ L each of the sample solution and standard solution, within 30 minutes after preparation of these solutions, as directed under Liquid Chromatography <2.01> according to the following conditions, and determine the peak areas, A_T and A_S , of imipenem in each solution.

$$\begin{aligned} &\text{Amount } [\mu\text{g (potency)}] \text{ of imipenem (C}_{12}\text{H}_{17}\text{N}_3\text{O}_4\text{S)} \\ &= M_S \times A_T/A_S \times 1000 \end{aligned}$$

M_S : Amount [mg (potency)] of Imipenem RS taken

Operating conditions—

Detector: An ultraviolet absorption photometer (wavelength: 280 nm).

Column: A stainless steel column 3.9 mm in inside diameter and 30 cm in length, packed with octadecylsilanized silica gel for liquid chromatography (10 μ m in particle diameter).

Column temperature: A constant temperature of about 25°C.

Mobile phase: A mixture of 0.1 mol/L 3-(*N*-morpholino)propanesulfonic acid buffer solution (pH 7.0) and acetonitrile (100:1).

Flow rate: Adjust so that the retention time of imipenem is about 6 minutes.

System suitability—

System performance: Dissolve 50 mg of Imipenem Hydrate and 75 mg of resorcinol in 50 mL of 0.1 mol/L 3-(*N*-morpholino)propanesulfonic acid buffer solution (pH 7.0). When the procedure is run with 10 μ L of this solution under the above operating conditions, imipenem and resorcinol are eluted in this order with the resolution between these peaks being not less than 4.

System repeatability: When the test is repeated 5 times with 10 μ L of the standard solution under the above operating conditions, the relative standard deviation of the peak area of imipenem is not more than 0.80%.

Containers and storage Containers—Hermetic containers.

Imipenem and Cilastatin Sodium for Injection

注射用イミペネム・シラスタチンナトリウム

Imipenem and Cilastatin Sodium for Injection is a preparation for injection which is dissolved or suspended before use.

It contains not less than 93.0% and not more than 115.0% of the labeled potency of imipenem (C₁₂H₁₇N₃O₄S: 299.35) and an amount of cilastatin sodium (C₁₆H₂₅N₂NaO₅S: 380.43), equivalent to not less than 93.0% and not more than 115.0% of the labeled amount of cilastatin (C₁₆H₂₆N₂O₅S: 358.45).

Method of preparation Prepare as directed under Injections, with Imipenem Hydrate and Cilastatin Sodium.

Description Imipenem and Cilastatin Sodium for Injection occurs as a white to light yellow-white powder.

Identification (1) To 1 mL of a solution of Imipenem and Cilastatin Sodium for Injection (1 in 100) add 1 mL of ninhydrin TS, heat in a water bath for 5 minutes: a purple color appears (cilastatin).

(2) To 2 mL of a solution of Imipenem and Cilastatin

Sodium for Injection (1 in 1000) add 0.1 mol/L 3-(*N*-morpholino)propanesulfonic acid buffer solution (pH 7.0) to make 50 mL, and determine the absorption spectrum of the solution as directed under Ultraviolet-visible Spectrophotometry <2.24>: it exhibits a maximum between 296 nm and 300 nm (imipenem).

pH <2.54> The pH of a solution prepared by dissolving an amount of Imipenem and Cilastatin Sodium for Injection, equivalent to 0.5 g (potency) of Imipenem Hydrate, in 100 mL of isotonic sodium chloride solution is between 6.5 and 8.0. The pH of the Injection intended for intramuscular use is between 6.0 and 7.5.

Purity Clarity and color of solution—Dissolve an amount of Imipenem and Cilastatin Sodium for Injection, equivalent to 0.5 g (potency) of Imipenem Hydrate, in 100 mL of isotonic sodium chloride solution: the solution is clear and colorless or pale yellow.

Loss on drying <2.41> Not more than 3.0% (1 g, in vacuum, 60°C, 3 hours).

Bacterial endotoxins <4.01> Less than 0.25 EU/mg (potency).

Uniformity of dosage units <6.02> Perform the test according to the following method: it meets the requirement of the Content uniformity test (*T*: 104.0%).

Dissolve the total amount of the content of 1 Imipenem and Cilastatin Sodium for Injection in isotonic sodium chloride solution to make exactly 100 mL. Measure exactly *V* mL of this solution, equivalent to about 25 mg (potency) of Imipenem Hydrate, add 0.1 mol/L 3-(*N*-morpholino)propanesulfonic acid buffer solution (pH 7.0) to make exactly 50 mL, and use this solution as the sample solution. Proceed hereafter as directed in the Assay.

$$\begin{aligned} \text{Amount [mg (potency)] of imipenem (C}_{12}\text{H}_{17}\text{N}_3\text{O}_4\text{S)} \\ = M_{\text{SI}} \times A_{\text{TI}}/A_{\text{SI}} \times 100/V \end{aligned}$$

$$\begin{aligned} \text{Amount (mg) of cilastatin (C}_{16}\text{H}_{26}\text{N}_2\text{O}_5\text{S)} \\ = M_{\text{SC}} \times A_{\text{TC}}/A_{\text{SC}} \times 100/V \times 0.955 \end{aligned}$$

M_{SI} : Amount [mg (potency)] of Imipenem RS taken

M_{SC} : Amount (mg) of cilastatin ammonium for assay taken, calculated on anhydrous and ethanol-free basis

Foreign insoluble matter <6.06> Perform the test according to Method 2: It meets the requirement.

Insoluble particulate matter <6.07> Perform the test according to the Method 1: the Injection which is dissolved before use meets the requirement.

Sterility <4.06> Perform the test according to the Membrane filtration method: it meets the requirement.

Assay Weigh accurately the mass of the contents of not less than 10 Imipenem and Cilastatin Sodium for Injections. Weigh accurately an amount of the content, equivalent to 1 Imipenem and Cilastatin Sodium for Injection, dissolve in isotonic sodium chloride solution to make exactly 100 mL. Measure exactly an amount of this solution, equivalent to about 25 mg (potency) of imipenem, add 0.1 mol/L 3-(*N*-morpholino)propanesulfonic acid buffer solution (pH 7.0) to make exactly 50 mL, and use this as the sample solution. Separately, weigh accurately an amount of Imipenem RS, equivalent to about 25 mg (potency), and weigh accurately about 25 mg of cilastatin ammonium for assay, dissolve in 10 mL of isotonic sodium chloride solution, add 0.1 mol/L 3-(*N*-morpholino)propanesulfonic acid buffer solution (pH

7.0) to make exactly 50 mL, and use this solution as the standard solution. Perform the test with exactly 10 μL each of the sample solution and standard solution as directed under Liquid Chromatography <2.01> according to the following conditions, and determine the peak areas, A_{TI} and A_{SI} of imipenem, and those, A_{TC} and A_{SC} of cilastatin in each solution.

$$\begin{aligned} \text{Amount [mg (potency)] of imipenem (C}_{12}\text{H}_{17}\text{N}_3\text{O}_4\text{S)} \\ = M_{\text{SI}} \times A_{\text{TI}}/A_{\text{SI}} \end{aligned}$$

$$\begin{aligned} \text{Amount (mg) of cilastatin (C}_{16}\text{H}_{26}\text{N}_2\text{O}_5\text{S)} \\ = M_{\text{SC}} \times A_{\text{TC}}/A_{\text{SC}} \times 0.955 \end{aligned}$$

M_{SI} : Amount [mg (potency)] of Imipenem RS taken

M_{SC} : Amount (mg) of cilastatin ammonium for assay taken, calculated on anhydrous and ethanol-free basis

Operating conditions—

Detector: An ultraviolet absorption photometer (wavelength: 250 nm).

Column: A stainless steel column 4.6 mm in inside diameter and 20 cm in length, packed with octylsilanized silica gel for liquid chromatography (10 μm in particle diameter).

Column temperature: A constant temperature of about 50°C.

Mobile phase: Dissolve 0.836 g of 3-(*N*-morpholino)propanesulfonic acid, 1.0 g of sodium 1-hexane sulfonate and 50 mg of disodium dihydrogen ethylenediamine tetraacetate dihydrate in 800 mL of water, adjust to pH 7.0 with 0.1 mol/L sodium hydrate TS, and add water to make 1000 mL.

Flow rate: Adjust so that the retention time of imipenem is about 3 minutes.

System suitability—

System performance: When the procedure is run with 10 μL of the standard solution under the above operating conditions, imipenem and cilastatin are eluted in this order with the resolution between these peaks being not less than 2.0, and the symmetry factors of the peak of imipenem and cilastatin are not more than 2.0, respectively.

System repeatability: When the test is repeated 6 times with 10 μL of the standard solution under the above operating conditions, the relative standard deviations of the peak area of imipenem and cilastatin are not more than 2.0%, respectively.

Containers and storage Containers—Hermetic containers. Plastic containers for aqueous injections may be used.

Imipramine Hydrochloride

イミプラミン塩酸塩



$\text{C}_{19}\text{H}_{24}\text{N}_2 \cdot \text{HCl}$: 316.87
3-(10,11-Dihydro-5*H*-dibenzo[*b,f*]azepin-5-yl)-*N,N*-dimethylpropylamine monohydrochloride
[113-52-0]

Imipramine Hydrochloride, when dried, contains not less than 98.5% of imipramine hydrochloride ($\text{C}_{19}\text{H}_{24}\text{N}_2 \cdot \text{HCl}$).

Description Imipramine Hydrochloride occurs as a white to pale yellow-white crystalline powder. It is odorless.

It is freely soluble in water and in ethanol (95), and practically insoluble in diethyl ether.

The pH of a solution of 0.1 g of Imipramine Hydrochloride in 10 mL of water is between 4.2 and 5.2.

It is gradually colored by light.

Identification (1) Dissolve 5 mg of Imipramine Hydrochloride in 2 mL of nitric acid: a deep blue color develops.

(2) Dissolve 5 mg of Imipramine Hydrochloride in 250 mL of 0.01 mol/L hydrochloric acid TS. Determine the absorption spectrum of the solution as directed under Ultraviolet-visible Spectrophotometry <2.24>, and compare the spectrum with the Reference Spectrum or the spectrum of a solution of Imipramine Hydrochloride RS prepared in the same manner as the sample solution: both spectra exhibit similar intensities of absorption at the same wavelengths.

(3) Dissolve 0.05 g of Imipramine Hydrochloride in 5 mL of water, add 1 mL of ammonia TS, allow to stand for 5 minutes, filter, and acidify the filtrate with dilute nitric acid: it responds to Qualitative Tests <1.09> (2) for chloride.

Melting point <2.60> 172 – 176°C (with decomposition).

Purity (1) Clarity and color of solution—Dissolve 1.0 g of Imipramine Hydrochloride in 10 mL of water: the solution is clear, and has no more color than the following control solution.

Control solution: Take exactly 1.0 mL of Cobalt (II) Chloride CS, 2.4 mL of Iron (III) Chloride CS, 0.4 mL of Copper (II) Sulfate CS and 6.2 mL of diluted hydrochloric acid (1 in 40), and mix them. Pipet 0.5 mL of this solution, and add exactly 9.5 mL of water.

(2) Iminodibenzyl—Dissolve 50 mg of Imipramine Hydrochloride in 10 mL of a mixture of hydrochloric acid and ethanol (95) (1:1) in a 25-mL brown volumetric flask. Cool the flask in ice water, add 5 mL of an ethanol (95) solution of furfural (1 in 250) and 5 mL of hydrochloric acid, and allow to stand at 25°C for 3 hours. Add a mixture of hydrochloric acid and ethanol (95) (1:1) to make 25 mL, and determine the absorbance of this solution at 565 nm as directed under Ultraviolet-visible Spectrophotometry <2.24>: it is not more than 0.16.

(3) Related substances—Dissolve 0.20 g of Imipramine Hydrochloride in 10 mL of ethanol (95), and use this solution as the sample solution. Pipet 1 mL of the sample solution, and add ethanol (95) to make exactly 50 mL. Pipet 5 mL of this solution, add ethanol (95) to make exactly 50 mL, and use this solution as the standard solution. Perform the test with these solutions as directed under Thin-layer Chromatography <2.03>. Spot 5 µL each of the sample solution and standard solution on a plate of silica gel for thin-layer chromatography. Develop the plate with a mixture of ethyl acetate, acetic acid (100), hydrochloric acid and water (11:7:1:1) to a distance of about 12 cm, and air-dry the plate. Spray evenly potassium dichromate-sulfuric acid TS on the plate: the spots other than the principal spot obtained from the sample solution are not more intense than the spot from the standard solution.

Loss on drying <2.41> Not more than 0.5% (1 g, 105°C, 2 hours).

Residue on ignition <2.44> Not more than 0.1% (1 g).

Assay Weigh accurately about 0.3 g of Imipramine Hydrochloride, previously dried, and dissolve in 20 mL of water. Add 5 mL of sodium hydroxide TS, and extract with three 20-mL portions of chloroform. Filter each extract through a

pledget of absorbent cotton on which a small quantity of anhydrous sodium sulfate is placed. Combine the chloroform extracts, and titrate <2.50> with 0.1 mol/L perchloric acid VS until the yellow solution changes to red-purple (indicator: 10 drops of metanil yellow TS). Perform a blank determination in the same manner, and make any necessary correction.

Each mL of 0.1 mol/L perchloric acid VS
= 31.69 mg of C₁₉H₂₄N₂.HCl

Containers and storage Containers—Tight containers.
Storage—Light-resistant.

Imipramine Hydrochloride Tablets

イミプラミン塩酸塩錠

Imipramine Hydrochloride Tablets contain not less than 93.0% and not more than 107.0% of the labeled amount of imipramine hydrochloride (C₁₉H₂₄N₂.HCl: 316.87).

Method of preparation Prepare as directed under Tablets, with Imipramine Hydrochloride.

Identification (1) Weigh a quantity of powdered Imipramine Hydrochloride Tablets, equivalent to 0.25 g of Imipramine Hydrochloride, add 25 mL of chloroform, shake thoroughly, and filter. Evaporate the filtrate on a water bath, and proceed with the residue as directed in the Identification (1) under Imipramine Hydrochloride.

(2) Dissolve an amount of the residue obtained in (1), equivalent to 5 mg of Imipramine Hydrochloride, in 250 mL of 0.01 mol/L hydrochloric acid TS, and determine the absorption spectrum as directed under Ultraviolet-visible Spectrophotometry <2.24>: it exhibits a maximum between 249 nm and 253 nm, and a shoulder between 270 nm and 280 nm.

Uniformity of dosage units <6.02> Perform the test according to the following method: it meets the requirement of the Content uniformity test.

To 1 tablet of Imipramine Hydrochloride Tablets add exactly 40 mL of 0.01 mol/L hydrochloric acid TS, disperse the tablet into a small particles by sonicating, then shake well. Centrifuge the solution, pipet *V* mL of the supernatant liquid, add water to make exactly *V'* mL so that each mL contains about 20 µg of imipramine hydrochloride (C₁₉H₂₄N₂.HCl), and use this solution as the sample solution. Separately, weigh accurately about 25 mg of Imipramine Hydrochloride RS, previously dried at 105°C for 2 hours, dissolve in 0.01 mol/L hydrochloric acid TS to make exactly 100 mL. Pipet 2 mL of this solution, add water to make exactly 25 mL, and use this solution as the standard solution. Determine the absorbances at 251 nm, *A*_{T1} and *A*_{S1}, and at 330 nm, *A*_{T2} and *A*_{S2}, of the sample solution and standard solution as directed under Ultraviolet-visible Spectrophotometry <2.24>.

Amount (mg) of imipramine hydrochloride (C₁₉H₂₄N₂.HCl)
= $M_S \times (A_{T1} - A_{T2}) / (A_{S1} - A_{S2}) \times V' / V \times 4 / 125$

*M*_S: Amount (mg) of Imipramine Hydrochloride RS taken

Dissolution <6.10> When the test is performed at 75 revolutions per minute according to the Paddle method, using 900 mL of 2nd fluid for dissolution test as the dissolution medium, the dissolution rate in 60 minutes of Imipramine Hydrochloride Tablets is not less than 75%.

Start the test with 1 tablet of Imipramine Hydrochloride Tablets, withdraw not less than 20 mL of the medium at the specified minute after starting the test, and filter through a membrane filter with a pore size not exceeding 0.8 μm . Discard not less than 10 mL of the first filtrate, pipet V mL of the subsequent filtrate, add the dissolution medium to make exactly V' mL so that each mL of the filtrate contains about 10 μg of imipramine hydrochloride ($\text{C}_{19}\text{H}_{24}\text{N}_2\cdot\text{HCl}$), and use this solution as the sample solution. Separately, weigh accurately about 25 mg of Imipramine Hydrochloride RS, previously dried at 105°C for 2 hours, dissolve in the dissolution medium to make exactly 100 mL. Pipet 4 mL of this solution, add the dissolution medium to make exactly 100 mL, and use this solution as the standard solution. Determine the absorbances, A_T and A_S , of the sample solution and the standard solution at 250 nm as directed under Ultraviolet-visible Spectrophotometry <2.24>.

Dissolution rate (%) with respect to the labeled amount of imipramine hydrochloride ($\text{C}_{19}\text{H}_{24}\text{N}_2\cdot\text{HCl}$)

$$= M_S \times A_T / A_S \times V' / V \times 1 / C \times 36$$

M_S : Amount (mg) of Imipramine Hydrochloride RS taken
 C : Labeled amount (mg) of imipramine hydrochloride ($\text{C}_{19}\text{H}_{24}\text{N}_2\cdot\text{HCl}$) in 1 tablet

Assay Take 20 Imipramine Hydrochloride Tablets, add exactly 200 mL of 0.01 mol/L hydrochloric acid TS, and shake well until the tablets are completely disintegrated. After centrifuging the solution, pipet a volume of the supernatant liquid, equivalent to about 25 mg of imipramine hydrochloride ($\text{C}_{19}\text{H}_{24}\text{N}_2\cdot\text{HCl}$), add 0.01 mol/L hydrochloric acid TS to make exactly 100 mL, and use this solution as the sample solution. Separately, weigh accurately about 25 mg of Imipramine Hydrochloride RS, previously dried at 105°C for 2 hours, dissolve in 0.01 mol/L hydrochloric acid TS to make exactly 100 mL, and use this solution as the standard solution. Pipet 3 mL each of these solutions into separators which contain 15 mL of potassium hydrogen phthalate buffer solution (pH 5.6), 8 mL of bromocresol green-sodium hydroxide TS and 30 mL of chloroform, and shake. Filter the chloroform layer through a pledget of absorbent cotton into a 100-mL volumetric flask. Repeat the extraction with two 30-mL portions of chloroform, combine the chloroform layers in the 100-mL volumetric flask, and add chloroform to make exactly 100 mL. Perform the test with these solutions as directed under Ultraviolet-visible Spectrophotometry <2.24>, using a solution obtained by proceeding with 3 mL of 0.01 mol/L hydrochloric acid TS in the same manner as the blank. Determine the absorbances, A_T and A_S , of these solutions at 416 nm.

Amount (mg) of imipramine hydrochloride ($\text{C}_{19}\text{H}_{24}\text{N}_2\cdot\text{HCl}$)

$$= M_S \times A_T / A_S$$

M_S : Amount (mg) of Imipramine Hydrochloride RS taken

Containers and storage Containers—Tight containers.

Indapamide

インダパミド

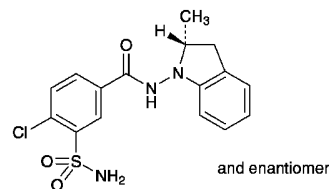

$\text{C}_{16}\text{H}_{16}\text{ClN}_3\text{O}_3\text{S}$: 365.83

4-Chloro-*N*-[(2*RS*)-2-methyl-2,3-dihydro-1*H*-indol-1-yl]-3-sulfamoylbenzamide
 [26807-65-8]

Indapamide contains not less than 98.5% and not more than 101.5% of indapamide ($\text{C}_{16}\text{H}_{16}\text{ClN}_3\text{O}_3\text{S}$), calculated on the dried basis.

Description Indapamide occurs as a white crystalline powder.

It is freely soluble in ethanol (99.5), and practically insoluble in water.

A solution of Indapamide in ethanol (99.5) (1 in 10) shows no optical rotation.

Identification (1) Determine the absorption spectrum of a solution of Indapamide in ethanol (99.5) (1 in 100,000) as directed under Ultraviolet-visible Spectrophotometry <2.24>, and compare the spectrum with the Reference Spectrum or the spectrum of a solution of Indapamide RS prepared in the same manner as the sample solution: both spectra exhibit similar intensities of absorption at the same wavelengths.

(2) Determine the infrared absorption spectrum of Indapamide as directed in the potassium bromide disk method under Infrared Spectrophotometry <2.25>, and compare the spectrum with the Reference Spectrum or the spectrum of Indapamide RS: both spectra exhibit similar intensities of absorption at the same wave numbers.

(3) Perform the test with Indapamide as directed under Flame Coloration Test <1.04> (2): a green color appears.

Melting point <2.60> 167 – 171°C

Purity (1) Chloride <1.03>—To 1.5 g of Indapamide add 50 mL of water, shake for 15 minutes, allow to stand in an ice bath for 30 minutes, and filter. To 30 mL of the filtrate add 6 mL of dilute nitric acid and water to make 50 mL. Perform the test using this solution as the test solution. Prepare the control solution with 0.25 mL of 0.01 mol/L hydrochloric acid VS (not more than 0.01%).

(2) Heavy metals <1.07>—Proceed with 2.0 g of Indapamide according to Method 2, and perform the test. Prepare the control solution with 2.0 mL of Standard Lead Solution (not more than 10 ppm).

(3) Related substances—Conduct this procedure using light-resistant vessels. Dissolve 0.10 g of Indapamide in 5 mL of ethanol (99.5), and use this solution as the sample solution. Pipet 1 mL of the sample solution, add ethanol (99.5) to make exactly 200 mL, and use this solution as the standard solution (1). Pipet 5 mL of the standard solution (1), add ethanol (99.5) to make exactly 10 mL, and use this solution as the standard solution (2). Perform the test with these solutions as directed under Thin-layer Chromatography <2.03>. Spot 10 μL each of the sample solution and standard solutions (1) and (2) on a plate of silica gel with fluorescent indicator for thin-layer chromatography. Immediately develop

the plate with a mixture of ethyl acetate, cyclohexane and acetic acid (100) (100:80:1) to a distance of about 10 cm, and air-dry the plate. Examine under ultraviolet light (main wavelength: 254 nm): the spots other than the principal spot obtained from the sample solution are not more intense than the spot from the standard solution (1), and the total amount of these related substances, calculated by comparison with the spots from the standard solutions (1) and (2), is not more than 2.0%.

Loss on drying <2.41> Not more than 3.0% (0.5 g, reduced pressure not exceeding 0.67 kPa, phosphorus (V) oxide, 110°C, 2 hours).

Residue on ignition <2.44> Not more than 0.1% (1 g).

Assay Weigh accurately about 20 mg each of Indapamide and Indapamide RS (separately, determine the loss on drying <2.41> under the same condition as Indapamide), and dissolve each in a mixture of water and ethanol (99.5) (1:1) to make exactly 100 mL. Pipet 10 mL each of these solutions, add exactly 2 mL of the internal standard solution and a mixture of water and ethanol (99.5) (1:1) to make 20 mL, and use these solutions as the sample solution and the standard solution, respectively. Perform the test with 10 μ L each of the sample solution and standard solution as directed under Liquid Chromatography <2.01> according to the following conditions, and calculate the ratios, Q_T and Q_S , of the peak area of indapamide to that of the internal standard.

$$\begin{aligned} &\text{Amount (mg) of indapamide (C}_{16}\text{H}_{16}\text{ClN}_3\text{O}_3\text{S)} \\ &= M_S \times Q_T/Q_S \end{aligned}$$

M_S : Amount (mg) of Indapamide RS taken, calculated on the dried basis

Internal standard solution—A solution of isopropyl parahydroxybenzoate in a mixture of water and ethanol (99.5) (1:1) (3 in 1000).

Operating conditions—

Detector: An ultraviolet absorption photometer (wavelength: 287 nm).

Column: A stainless steel column 4.6 mm in inside diameter and 15 cm in length, packed with octadecylsilanized silica gel for liquid chromatography (5 μ m in particle diameter).

Column temperature: A constant temperature of about 40°C.

Mobile phase: A mixture of diluted phosphoric acid (1 in 1000), acetonitrile and methanol (6:3:1).

Flow rate: Adjust so that the retention time of indapamide is about 6 minutes.

System suitability—

System performance: When the procedure is run with 10 μ L of the standard solution under the above operating conditions, indapamide and the internal standard are eluted in this order with the resolution between these peaks being not less than 4.

System repeatability: When the test is repeated 6 times with 10 μ L of the standard solution under the above operating conditions, the relative standard deviation of the peak area of indapamide is not more than 1.0%.

Containers and storage Containers—Tight containers.

Storage—Light-resistant.

Indapamide Tablets

インダパミド錠

Indapamide Tablets contain not less than 93.0% and not more than 103.0% of the labeled amount of indapamide (C₁₆H₁₆ClN₃O₃S: 365.83).

Method of preparation Prepare as directed under Tablets, with Indapamide.

Identification To an amount of powdered Indapamide Tablets, equivalent to 10 mg of Indapamide, add 5 mL of ethyl acetate, shake for 10 minutes, centrifuge, and use the supernatant liquid as the sample solution. Separately, dissolve 10 mg of Indapamide RS in 5 mL of ethyl acetate, and use this solution as the standard solution. Perform the test with these solutions as directed under Thin-layer Chromatography <2.03>. Spot 10 μ L each of the sample solution and standard solution on a plate of silica gel with fluorescent indicator for thin-layer chromatography. Develop the plate with a mixture of ethyl acetate, cyclohexane and acetic acid (100) (100:80:1) to a distance of about 10 cm, and air-dry the plate. Examine under ultraviolet light (main wavelength: 254 nm): the principal spot obtained from the sample solution and the spot from the standard solution show a blue-purple color and the same R_f value.

Uniformity of dosage units <6.02> Perform the test according to the following method: it meets the requirement of the Content uniformity test.

To 1 tablet of Indapamide Tablets add exactly $V/10$ mL of the internal standard solution, and add a mixture of water and ethanol (99.5) (1:1) to make V mL so that each mL contains about 0.1 mg of indapamide (C₁₆H₁₆ClN₃O₃S), shake to disintegrate, sonicate for 10 minutes, shake again for 10 minutes, centrifuge, and use the supernatant liquid as the sample solution. Proceed as directed in the Assay.

$$\begin{aligned} &\text{Amount (mg) of indapamide (C}_{16}\text{H}_{16}\text{ClN}_3\text{O}_3\text{S)} \\ &= M_S \times Q_T/Q_S \times V/200 \end{aligned}$$

M_S : Amount (mg) of Indapamide RS taken, calculated on the dried basis

Internal standard solution—A solution of isopropyl parahydroxybenzoate in a mixture of water and ethanol (99.5) (1:1) (3 in 1000).

Dissolution <6.10> When the test is performed at 50 revolutions per minute according to the Paddle method, using 900 mL of water as the dissolution medium, the dissolution rates in 45 minutes of 1-mg tablet and in 90 minutes of 2-mg tablet are not less than 70%, respectively.

Start the test with 1 tablet of Indapamide Tablets, withdraw not less than 20 mL of the medium at the specified minute after starting the test, and filter through a membrane filter with a pore size not exceeding 0.45 μ m. Discard not less than 10 mL of the first filtrate, pipet V mL of the subsequent filtrate, add water to make exactly V' mL so that each mL contains about 1.1 μ g of indapamide (C₁₆H₁₆ClN₃O₃S), and use this solution as the sample solution. Separately, weigh accurately about 20 mg of Indapamide RS (separately, determine the loss on drying <2.41> under the same condition as Indapamide), and dissolve in ethanol (99.5) to make exactly 50 mL. Pipet 5 mL of this solution, and add water to make exactly 100 mL. Pipet 5 mL of this solution, add water to make exactly 100 mL, and use this solution as the standard solution. Perform the test with exactly 50 μ L each of the

sample solution and standard solution as directed under Liquid Chromatography <2.01> according to the following conditions, and determine the peak areas, A_T and A_S , of indapamide in each solution.

Dissolution rate (%) with respect to the labeled amount of indapamide ($C_{16}H_{16}ClN_3O_3S$)

$$= M_S \times A_T/A_S \times V'/V \times 1/C \times 9/2$$

M_S : Amount (mg) of Indapamide RS taken, calculated on the dried basis

C : Labeled amount (mg) of indapamide ($C_{16}H_{16}ClN_3O_3S$) in 1 tablet

Operating conditions—

Proceed as directed in the operating conditions in the Assay under Indapamide.

System suitability—

System performance: When the procedure is run with 50 μ L of the standard solution under the above operating conditions, the number of theoretical plates and the symmetry factor of the peak of indapamide are not less than 3500 and not more than 1.5, respectively.

System repeatability: When the test is repeated 6 times with 50 μ L of the standard solution under the above operating conditions, the relative standard deviation of the peak area of indapamide is not more than 1.5%.

Assay To 20 Indapamide Tablets add 80 mL of a mixture of water and ethanol (99.5) (1:1), shake well to disintegrate, and sonicate for 10 minutes. Shake the solution for 10 minutes, and add a mixture of water and ethanol (99.5) (1:1) to make exactly 100 mL. Pipet a volume of indapamide ($C_{16}H_{16}ClN_3O_3S$), equivalent to about 2 mg, and add exactly 2 mL of the internal standard solution and a mixture of water and ethanol (99.5) (1:1) to make 20 mL. Centrifuge this solution, and use the supernatant liquid as the sample solution. Separately, weigh accurately about 20 mg of Indapamide RS (separately, determine the loss on drying <2.41> under the same condition as Indapamide), and dissolve in a mixture of water and ethanol (99.5) (1:1) to make exactly 100 mL. Pipet 10 mL of this solution, add exactly 2 mL of the internal standard solution and a mixture of water and ethanol (99.5) (1:1) to make 20 mL, and use this solution as the standard solution. Proceed as directed in the Assay under Indapamide.

Amount (mg) of indapamide ($C_{16}H_{16}ClN_3O_3S$)

$$= M_S \times Q_T/Q_S \times 1/10$$

M_S : Amount [mg (potency)] of Indapamide RS taken, calculated on the dried basis

Internal standard solution—A solution of isopropyl parahydroxybenzoate in a mixture of water and ethanol (99.5) (1:1) (3 in 1000).

Containers and storage Containers—Tight containers.

Indenolol Hydrochloride

インデノロール塩酸塩

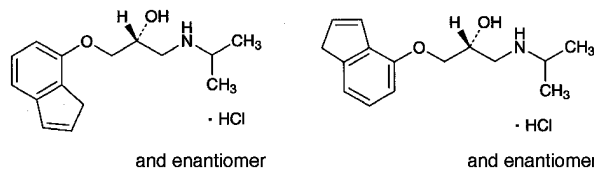

$C_{15}H_{21}NO_2 \cdot HCl$: 283.79

(2RS)-1-(3H-Inden-4-yloxy)-3-(1-methylethyl)aminopropan-2-ol monohydrochloride
(2RS)-1-(3H-Inden-7-yloxy)-3-(1-methylethyl)aminopropan-2-ol monohydrochloride
[68906-88-7]

Indenolol Hydrochloride is a mixture of (2RS)-1-(3H-Inden-4-yloxy)-3-(1-methylethyl)aminopropan-2-ol monohydrochloride and (2RS)-1-(3H-Inden-7-yloxy)-3-(1-methylethyl)aminopropan-2-ol monohydrochloride.

When dried, it contains not less than 98.5% of indenolol hydrochloride ($C_{15}H_{21}NO_2 \cdot HCl$).

Description Indenolol Hydrochloride occurs as white to pale yellow, crystals or crystalline powder.

It is freely soluble in water and in acetic acid (100), soluble in ethanol (95) and in chloroform, slightly soluble in acetic anhydride, very slightly soluble in ethyl acetate, and practically insoluble in diethyl ether.

The pH of a solution of 1.0 g of Indenolol Hydrochloride in 10 mL of water is between 3.5 and 5.5.

It is colored by light.

Identification (1) Dissolve 0.1 g of Indenolol Hydrochloride in 1 to 2 drops of dilute hydrochloric acid and 5 mL of water, and add 1 mL of Reinecke salt TS: a red-purple precipitate is formed.

(2) Determine the absorption spectrum of a solution of Indenolol Hydrochloride (1 in 50,000) as directed under Ultraviolet-visible Spectrophotometry <2.24>, and compare the spectrum with the Reference Spectrum 1: both spectra exhibit similar intensities of absorption at the same wavelengths. Separately, determine the absorption spectrum of a solution of Indenolol Hydrochloride (1 in 10,000) as directed under Ultraviolet-visible Spectrophotometry <2.24>, and compare the spectrum with the Reference Spectrum 2: both spectra exhibit similar intensities of absorption at the same wavelengths.

(3) Determine the infrared absorption spectrum of Indenolol Hydrochloride, previously dried, as directed in the potassium chloride disk method under Infrared Spectrophotometry <2.25>, and compare the spectrum with the Reference Spectrum: both spectra exhibit similar intensities of absorption at the same wave numbers.

(4) A solution of Indenolol Hydrochloride (1 in 10) responds to Qualitative Tests <1.09> for chloride.

Absorbance <2.24> $E_{1\text{cm}}^{1\%}$ (250 nm): 330 – 340 (after drying, 10 mg, water, 1000 mL).

Melting point <2.60> 140 – 143°C

Purity (1) Clarity and color of solution—Dissolve 1.0 g of Indenolol Hydrochloride in 10 mL of water: the solution is clear and colorless to pale yellow.

(2) Heavy metals <1.07>—Proceed with 1.0 g of In-

denolol Hydrochloride according to Method 2, and perform the test. Prepare the control solution with 2.0 mL of Standard Lead Solution (not more than 20 ppm).

(3) Arsenic <1.11>—Prepare the test solution with 1.0 g of Indenolol Hydrochloride according to Method 1, and perform the test (not more than 2 ppm).

(4) Related substances—Dissolve 0.20 g of Indenolol Hydrochloride in 10 mL of chloroform, and use this solution as the sample solution. Pipet 1 mL of the sample solution, add chloroform to make exactly 200 mL, and use this solution as the standard solution. Perform the test with these solutions as directed under Thin-layer Chromatography <2.03>. Spot 10 μ L each of the sample solution and standard solution on a plate of silica gel with fluorescent indicator for thin-layer chromatography. Develop the plate with a mixture of 1,2-dichloroethane, ethanol (99.5) and ammonia solution (28) (70:15:2) to a distance of about 12 cm, and air-dry the plate. Examine under ultraviolet light (main wavelength: 254 nm): the spots other than the principal spot obtained from the sample solution are not more intense than the spot from the standard solution.

Loss on drying <2.41> Not more than 0.5% (1 g, in vacuum, phosphorus (V) oxide, 4 hours).

Residue on ignition <2.44> Not more than 0.1% (1 g).

Isomer ratio Dissolve 5 mg of Indenolol Hydrochloride in 1.0 mL of a mixture of ethyl acetate and trifluoroacetic anhydride for gas chromatography (9:1), and use this solution as the sample solution. Perform the test with 2 μ L of the sample solution as directed under Gas Chromatography <2.02> according to the following conditions. Determine the areas of two adjacent peaks, A_a and A_b , having the retention times of about 16 minutes, where A_a is the peak area of shorter retention time and A_b is the peak area of longer retention time: the ratio $A_a/(A_a + A_b)$ is between 0.6 and 0.7.

Operating conditions—

Detector: A hydrogen flame-ionization detector.

Column: A glass column about 2 mm in inside diameter and about 2 m in length, packed with siliceous earth for gas chromatography (150 to 180 μ m in particle diameter) coated with 65% phenyl-methyl silicon polymer for gas chromatography at the ratio of 2%.

Column temperature: A constant temperature between 150°C and 170°C.

Carrier gas: Helium.

Flow rate: Adjust so that the retention time of the peak showing earlier elution of the two peaks of indenolol hydrochloride is about 16 minutes.

Selection of column: Proceed with 2 μ L of the sample solution under the above operating conditions, and calculate the resolution. Use a column with the resolution between the two peaks being not less than 1.1.

Assay Weigh accurately about 0.5 g of Indenolol Hydrochloride, previously dried, dissolve in 50 mL of a mixture of acetic anhydride and acetic acid (100) (4:1), and titrate <2.50> with 0.1 mol/L perchloric acid VS until the color of the solution changes from purple through blue to green (indicator: 3 drops of crystal violet TS). Perform a blank determination in the same manner, and make any necessary correction.

Each mL of 0.1 mol/L perchloric acid VS
= 28.38 mg of $C_{16}H_8N_2Na_2O_8S_2 \cdot HCl$

Containers and storage Containers—Well-closed containers.

Storage—Light-resistant.

Indigocarmine

インジゴカルミン

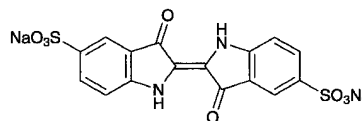

$C_{16}H_8N_2Na_2O_8S_2$: 466.35

Disodium 3,3'-dioxo-[4^{2,2'}-biindoline]-5,5'-disulfonate
[860-22-0]

Indigocarmine, when dried, contains not less than 95.0% of indigocarmine ($C_{16}H_8N_2Na_2O_8S_2$).

Description Indigocarmine occurs as a blue to dark blue, powder or granules. It is odorless.

It is sparingly soluble in water, and practically insoluble in ethanol (95) and in diethyl ether.

It is hygroscopic.

When compressed, it has a coppery luster.

Identification (1) A solution of Indigocarmine (1 in 100) is dark blue in color. Perform the following tests with this solution as the sample solution: the dark blue color of each solution disappears.

(i) Add 1 mL of nitric acid to 2 mL of the sample solution;

(ii) Add 1 mL of bromine TS to 2 mL of the sample solution;

(iii) Add 1 mL of chlorine TS to 2 mL of the sample solution;

(iv) Add 2 mL of sodium hydroxide TS and 0.2 g of zinc powder to 2 mL of the sample solution, and warm.

(2) Dissolve 0.1 g of Indigocarmine in 100 mL of a solution of ammonium acetate (1 in 650). To 1 mL of the solution add a solution of ammonium acetate (1 in 650) to make 100 mL. Determine the absorption spectrum of the solution as directed under Ultraviolet-visible Spectrophotometry <2.24>, and compare the spectrum with the Reference Spectrum: both spectra exhibit similar intensities of absorption at the same wavelengths.

(3) Ignite 1 g of Indigocarmine to carbonize. After cooling, add 20 mL of water to the residue, shake, and filter the mixture: the filtrate responds to Qualitative Tests <1.09> for sodium salt and for sulfate.

pH <2.54> Dissolve 0.10 g of Indigocarmine in 20 mL of water: the pH of the solution is between 5.0 and 6.0.

Purity (1) Water-insoluble substances—To 1.00 g of Indigocarmine add 200 mL of water, shake, and filter through a tared glass filter (G4). Wash the residue with water until the blue color of the filtrate becomes practically colorless, and dry the residue at 105°C for 4 hours: the mass of the residue does not exceed 5.0 mg.

(2) Arsenic <1.11>—Place 0.8 g of Indigocarmine in a Kjeldahl flask, add 5 mL of sulfuric acid and 5 mL of nitric acid, and ignite gently. Repeat the addition of 2 to 3 mL of nitric acid occasionally, and continue to heat until a colorless to light yellow solution is obtained. After cooling, add 15 mL of a saturated ammonium oxalate solution, heat the solution until dense white fumes are evolved, and concentrate to 2 to 3 mL. After cooling, dilute with water to 10 mL, and perform the test with 5 mL of this solution as the test solution (not more than 5 ppm).

Loss on drying <2.41> Not more than 10.0% (1 g, 105°C, 2 hours).

Residue on ignition <2.44> Not less than 28% and not more than 38% (after drying, 1 g).

Assay Weigh accurately about 0.5 g of Indigocarmine, previously dried, add 15 g of sodium hydrogen tartrate monohydrate, and dissolve in 200 mL of water, boil with bubbling of a stream of carbon dioxide, and titrate <2.50>, while being hot, with 0.1 mol/L titanium (III) chloride VS until the color of the solution changes from blue through yellow to orange.

Each mL of 0.1 mol/L titanium (III) chloride VS
= 23.32 mg of $C_{16}H_8N_2Na_2O_8S_2$

Containers and storage Containers—Tight containers.
Storage—Light-resistant.

Indigocarmine Injection

インジゴカルミン注射液

Indigocarmine Injection is an aqueous injection.

It contains not less than 95.0% and not more than 105.0% of the labeled amount of indigocarmine ($C_{16}H_8N_2Na_2O_8S_2$; 466.35).

Method of preparation Prepare as directed under Injection, with Indigocarmine.

Description Indigocarmine Injection is a dark blue liquid.
pH: 3.0 – 5.0

Identification (1) To a volume of Indigocarmine Injection, equivalent to 20 mg of Indigocarmine, add 1 mL of nitric acid: the dark blue color of the liquid disappears, and a yellow-brown color develops.

(2) To a volume of Indigocarmine Injection, equivalent to 20 mg of Indigocarmine, add 1 mL of bromine TS: the dark blue color disappears, and a yellow-brown color develops.

(3) To a volume of Indigocarmine Injection, equivalent to 20 mg of Indigocarmine, add 1 mL of chlorine TS: the dark blue color disappears, and a yellow-brown color develops.

(4) To a volume of Indigocarmine Injection, equivalent to 10 mg of Indigocarmine, add ammonium acetate solution (1 in 650) to make 1000 mL, and determine the absorbance of the solution as directed under Ultraviolet-visible Spectrophotometry <2.24>: it exhibits a maximum between 610 nm and 614 nm.

Bacterial endotoxins <4.01> Less than 7.5 EU/mg.

Extractable volume <6.05> It meets the requirement.

Foreign insoluble matter <6.06> Perform the test according to Method 1: it meets the requirement.

Insoluble particulate matter <6.07> Perform the test according to Method 2: it meets the requirement.

Sterility <4.06> Perform the test according to the Membrane filtration method: it meets the requirement.

Assay Measure exactly a volume of Indigocarmine Injection, equivalent to about 0.2 g of indigocarmine ($C_{16}H_8N_2Na_2O_8S_2$), add 6 g of sodium hydrogen tartrate monohydrate, and dissolve in water to make 200 mL. Then boil under a carbon dioxide stream, and proceed as directed in the Assay under Indigocarmine.

Each mL of 0.1 mol/L titanium (III) chloride VS
= 23.32 mg of $C_{16}H_8N_2Na_2O_8S_2$

Containers and storage Containers—Hermetic containers, and colored containers may be used.

Storage—Light-resistant.

Indium (^{111}In) Chloride Injection

塩化インジウム (^{111}In) 注射液

Indium (^{111}In) Chloride Injection is an aqueous injection.

It contains indium-111 (^{111}In) in the form of indium chloride.

It conforms to the requirements of Indium (^{111}In) Chloride Injection in the Minimum Requirements for Radiopharmaceuticals.

Test for Extractable Volume of Parenteral Preparations and Insoluble Particulate Matter Test for Injections are not applied to this injection.

Description Indium (^{111}In) Chloride Injection is a clear, colorless liquid.

Indometacin

インドメタシン

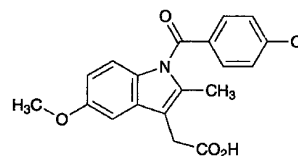

$C_{19}H_{16}ClNO_4$; 357.79
[1-(4-Chlorobenzoyl)-5-methoxy-2-methyl-1H-indol-3-yl]acetic acid
[53-86-1]

Indometacin, when dried, contains not less than 98.0% of indometacin ($C_{19}H_{16}ClNO_4$).

Description Indometacin occurs as a white to light yellow, fine, crystalline powder.

It is sparingly soluble in methanol, in ethanol (95) and in diethyl ether, and practically insoluble in water.

It dissolves in sodium hydroxide TS.

It is colored by light.

Melting point: 155 – 162°C

It shows crystal polymorphism.

Identification (1) Dissolve 2 mg of Indometacin in 100 mL of methanol. Determine the absorption spectrum of the solution as directed under Ultraviolet-visible Spectrophotometry <2.24>, and compare the spectrum with the Reference Spectrum or the spectrum of a solution of Indometacin RS prepared in the same manner as the sample solution: both spectra exhibit similar intensities of absorption at the same wavelengths.

(2) Determine the infrared absorption spectrum of Indometacin, previously dried, as directed in the potassium bromide disk method under Infrared Spectrophotometry <2.25>, and compare the spectrum with the Reference Spectrum or the spectrum of dried Indometacin RS: both spectra exhibit similar intensities of absorption at the same wave numbers.

If any difference appears between the spectra, recrystallize the sample and the RS with diethyl ether, filter and dry the crystals, and perform the test with the crystals.

(3) Perform the test with Indometacin as directed under Flame Coloration Test <1.04> (2): a green color appears.

Purity (1) Acidity—To 1.0 g of Indometacin add 50 mL of water, shake for 5 minutes, and filter. To the filtrate add 0.20 mL of 0.1 mol/L sodium hydroxide VS and 1 drop of phenolphthalein TS: a red color develops.

(2) Heavy metals <1.07>—Proceed with 1.0 g of Indometacin according to Method 2, and perform the test. Prepare the control solution with 2.0 mL of Standard Lead Solution (not more than 20 ppm).

(3) Arsenic <1.11>—Prepare the test solution with 1.0 g of Indometacin according to Method 3, and perform the test (not more than 2 ppm).

(4) Related substances—Dissolve 0.10 g of Indometacin in 10 mL of methanol, and use this solution as the sample solution. Pipet 1 mL of the sample solution, and add methanol to make exactly 50 mL. Pipet 5 mL of this solution, add methanol to make exactly 20 mL, and use this solution as the standard solution. Perform the test with these solutions as directed under Thin-layer Chromatography <2.03>. Spot 25 μ L each of the sample solution and standard solution on a plate of silica gel with fluorescent indicator for thin-layer chromatography. Develop the plate with a mixture of dehydrated diethyl ether and acetic acid (100) (100:3) to a distance of about 10 cm, and air-dry the plate. Examine under ultraviolet light (main wavelength: 254 nm): the spots other than the principal spot obtained from the sample solution are not more intense than the spot from the standard solution.

Loss on drying <2.41> Not more than 0.5% (1 g, 105°C, 4 hours).

Residue on ignition <2.44> Not more than 0.1% (1 g).

Assay Weigh accurately about 0.7 g of Indometacin, previously dried, dissolve in 60 mL of methanol, add 30 mL of water, and titrate <2.50> with 0.1 mol/L sodium hydroxide VS (indicator: 3 drops of phenolphthalein TS). Perform a blank determination in the same manner, and make any necessary correction.

$$\begin{aligned} &\text{Each mL of 0.1 mol/L sodium hydroxide VS} \\ &= 35.78 \text{ mg of } C_{19}H_{16}ClNO_4 \end{aligned}$$

Containers and storage Containers—Tight containers.

Storage—Light-resistant.

Indometacin Capsules

インドメタシンカプセル

Indometacin Capsules contain not less than 90.0% and not more than 110.0% of the labeled amount of indometacin ($C_{19}H_{16}ClNO_4$; 357.79).

Method of preparation Prepare as directed under Capsules, with Indometacin.

Identification Powder the contents of Indometacin Capsules. To a quantity of the powder, equivalent to 0.1 g of Indometacin, add 20 mL of chloroform, shake well, and centrifuge. Filter the supernatant liquid, and evaporate the filtrate to dryness. After cooling, dissolve the residue in 20 mL of methanol. To 10 mL of this solution add methanol to

make 50 mL, then to 2 mL of this solution add methanol to make 100 mL, and use this solution as the sample solution. Determine the absorption spectrum of the sample solution as directed under Ultraviolet-visible Spectrophotometry <2.24>: it exhibits a maximum between 317 nm and 321 nm.

Purity Related substances—Powder the content of Indometacin Capsules. To a quantity of the powder, equivalent to 0.10 g of Indometacin, add exactly 10 mL of methanol, shake well, filter, and use the filtrate as the sample solution. Dissolve 25 mg of Indometacin RS in methanol to make exactly 50 mL. Pipet 1 mL of the solution, add methanol to make exactly 10 mL, and use this solution as the standard solution. Proceed as directed in the Purity (4) under Indometacin.

Uniformity of dosage units <6.02> Perform the test according to the following method: it meets the requirement of the Content uniformity test.

Take out the content of 1 capsule of Indometacin Capsules, and dissolve in methanol to make exactly V mL so that each mL contains about 1 mg of indometacin ($C_{19}H_{16}ClNO_4$). Filter the solution, discard the first 10 mL of the filtrate, pipet 5 mL of the subsequent filtrate, add exactly 3 mL of the internal standard solution, then add the mobile phase to make 100 mL, and use this solution as the sample solution. Separately, weigh accurately about 25 mg of Indometacin RS, previously dried at 105°C for 4 hours, dissolve in methanol to make exactly 25 mL. Pipet 5 mL of this solution, add exactly 3 mL of the internal standard solution, then add the mobile phase to make 100 mL, and use this solution as the standard solution. Then, proceed as directed in the Assay.

$$\begin{aligned} &\text{Amount (mg) of indometacin } (C_{19}H_{16}ClNO_4) \\ &= M_S \times Q_T / Q_S \times V / 25 \end{aligned}$$

M_S : Amount (mg) of Indometacin RS taken

Internal standard solution—A solution of butyl parahydroxybenzoate in methanol (1 in 1000).

Dissolution <6.10> When the test is performed at 100 revolutions per minute according to the Basket method, using 900 mL of a mixture of water and phosphate buffer solution (pH 7.2) (4:1) as the dissolution medium, the dissolution rate in 20 minutes of Indometacin Capsules is not less than 75%.

Start the test with 1 capsule of Indometacin Capsules, withdraw not less than 20 mL of the medium at the specified minute after starting the test, and filter through a membrane filter with a pore size not exceeding 0.8 μ m. Discard not less than 10 mL of the first filtrate, pipet V mL of the subsequent filtrate, add the dissolution medium to make exactly V' mL so that each mL contains about 28 μ g of indometacin ($C_{19}H_{16}ClNO_4$), and use this solution as the sample solution. Separately, weigh accurately about 30 mg of Indometacin RS, previously dried at 105°C for 4 hours, dissolve in the dissolution medium to make exactly 1000 mL, and use this solution as the standard solution. Determine the absorbances, A_T and A_S , of the sample solution and the standard solution at 320 nm as directed under Ultraviolet-visible Spectrophotometry <2.24>.

$$\begin{aligned} &\text{Dissolution rate (\%)} \text{ with respect to the labeled amount} \\ &\text{of indometacin } (C_{19}H_{16}ClNO_4) \\ &= M_S \times A_T / A_S \times 1 / C \times 90 \end{aligned}$$

M_S : Amount (mg) of Indometacin RS taken

C : Labeled amount (mg) of indometacin ($C_{19}H_{16}ClNO_4$) in 1 capsule

Assay Weigh accurately the contents of not less than 20 Indometacin Capsules. Powder the combined contents, and weigh accurately a portion of the powder, equivalent to about 50 mg of indometacin ($C_{19}H_{16}ClNO_4$). Dissolve in 40 mL of methanol, and add methanol to make exactly 50 mL. Filter this solution, discarding the first 10-mL portion of the filtrate. Pipet 5 mL of the subsequent filtrate, add exactly 3 mL of the internal standard solution, add the mobile phase to make 100 mL, and use this solution as the sample solution. Separately, weigh accurately about 50 mg of Indometacin RS, previously dried at 105°C for 4 hours, and dissolve in methanol to make exactly 50 mL. Pipet 5 mL of the solution, add exactly 3 mL of the internal standard solution, add the mobile phase to make 100 mL, and use this solution as the standard solution. Perform the test with 20 μ L each of the sample solution and standard solution as directed under Liquid Chromatography <2.01> according to the following conditions, and calculate the ratios, Q_T and Q_S , of the peak area of indometacin to that of the internal standard, respectively.

$$\begin{aligned} & \text{Amount (mg) of indometacin (C}_{19}\text{H}_{16}\text{ClNO}_4\text{)} \\ & = M_S \times Q_T / Q_S \end{aligned}$$

M_S : Amount (mg) of Indometacin RS taken

Internal standard solution—A solution of butyl parahydroxybenzoate in methanol (1 in 1000).

Operating conditions—

Detector: An ultraviolet absorption photometer (wavelength: 254 nm).

Column: A stainless steel column 4.6 mm in inside diameter and 25 cm in length, packed with octadecylsilanized silica gel for liquid chromatography (7 μ m in particle diameter).

Column temperature: A constant temperature of about 25°C.

Mobile phase: A mixture of methanol and diluted phosphoric acid (1 in 1000) (7:3).

Flow rate: Adjust so that the retention time of indometacin is about 8 minutes.

System suitability—

System performance: Dissolve 50 mg of 4-chlorobenzoic acid, 30 mg of butyl parahydroxybenzoate and 50 mg of indometacin in 50 mL of methanol. To 5 mL of this solution add the mobile phase to make 100 mL. When the procedure is run with 20 μ L of this solution under the above operating conditions, 4-chlorobenzoic acid, butyl parahydroxybenzoate and indometacin are eluted in this order, with the resolution between the peaks of 4-chlorobenzoic acid and butyl parahydroxybenzoate being not less than 2.0, and between the peaks of butyl parahydroxybenzoate and indometacin being not less than 5.

System repeatability: When the test is repeated 6 times with 20 μ L of the standard solution under the above operating conditions, the relative standard deviation of the ratios of the peak area of indometacin to that of the internal standard is not more than 1.0%.

Containers and storage Containers—Tight containers.

Indometacin Suppositories

インドメタシン坐剤

Indometacin Suppositories contain not less than 90.0% and not more than 110.0% of the labeled amount of indometacin ($C_{19}H_{16}ClNO_4$; 357.79).

Method of preparation Prepare as directed under Suppositories, with Indometacin.

Identification Dissolve a quantity of Indometacin Suppositories, equivalent to 50 mg of Indometacin, in 20 mL of methanol by warming, add methanol to make 50 mL, and filter if necessary. To 2 mL of this solution add methanol to make 100 mL, and use this solution as the sample solution. Determine the absorption spectrum of the sample solution as directed under Ultraviolet-visible Spectrophotometry <2.24>: it exhibits a maximum between 317 nm and 321 nm.

Uniformity of dosage units <6.02> Perform the test according to the following method: it meets the requirement of the Content uniformity test.

To 1 suppository of Indometacin Suppositories add 80 mL of a mixture of methanol and acetic acid (100) (200:1), dissolve by warming, add a mixture of methanol and acetic acid (100) (200:1) to make exactly 100 mL. Pipet V mL of this solution, equivalent to about 2 mg of indometacin ($C_{19}H_{16}ClNO_4$), add a mixture of methanol and acetic acid (100) (200:1) to make exactly 50 mL, and use this solution as the sample solution. Separately, weigh accurately about 0.1 g of Indometacin RS, previously dried at 105°C for 4 hours, and dissolve in a mixture of methanol and acetic acid (100) (200:1) to make exactly 100 mL. Pipet 4 mL of this solution, add a mixture of methanol and acetic acid (100) (200:1) to make exactly 100 mL, and use this solution as the standard solution. Perform the test with the sample solution and standard solution as directed under Ultraviolet-visible Spectrophotometry <2.24>, and determine the absorbances, A_T and A_S , at 320 nm.

$$\begin{aligned} & \text{Amount (mg) of indometacin (C}_{19}\text{H}_{16}\text{ClNO}_4\text{)} \\ & = M_S \times A_T / A_S \times 2 / V \end{aligned}$$

M_S : Amount (mg) of Indometacin RS taken

Assay Weigh accurately not less than 20 Indometacin Suppositories, cut into small pieces carefully, and mix well. Weigh accurately a portion of the mass, equivalent to about 50 mg of indometacin ($C_{19}H_{16}ClNO_4$), add 40 mL of tetrahydrofuran, warm at 40°C, dissolve by shaking, cool, and add tetrahydrofuran to make exactly 50 mL. Filter the solution, discard the first 10 mL of the filtrate, pipet 5 mL of the subsequent filtrate, add exactly 3 mL of the internal standard solution, and add the mobile phase to make 100 mL. Allow the solution to stand for 30 minutes, filter through a membrane filter (0.5 μ m pore size), discard the first 10 mL of the filtrate, and use the subsequent filtrate as the sample solution. Separately, weigh accurately about 50 mg of Indometacin RS, previously dried at 105°C for 4 hours, and dissolve in tetrahydrofuran to make exactly 50 mL. Pipet 5 mL of the solution, proceed in the same manner as the sample solution, and use this solution as the standard solution. Perform the test with 20 μ L each of the sample solution and standard solution as directed under Liquid Chromatography <2.01> according to the following conditions, and calculate the ratios, Q_T and Q_S , of the peak area of indometacin to that of the internal standard, respectively.

$$\begin{aligned} & \text{Amount (mg) of indometacin (C}_{19}\text{H}_{16}\text{ClNO}_4\text{)} \\ & = M_S \times Q_T/Q_S \end{aligned}$$

M_S : Amount (mg) of Indometacin RS taken

Internal standard solution—A solution of butyl parahydroxybenzoate in methanol (1 in 1000).

Operating conditions—

Detector: An ultraviolet absorption photometer (wavelength: 254 nm).

Column: A stainless steel column 4.0 mm in inside diameter and 25 cm in length, packed with octadecylsilanized silica gel for liquid chromatography (7 μm in particle diameter).

Column temperature: A constant temperature of about 25°C.

Mobile phase: A mixture of methanol and diluted phosphoric acid (1 in 1000) (7:3).

Flow rate: Adjust so that the retention time of indometacin is about 8 minutes.

System suitability—

System performance: Dissolve 50 mg of 4-chlorobenzoic acid, 30 mg of butyl parahydroxybenzoate and 50 mg of indometacin in 50 mL of methanol. To 5 mL of this solution add the mobile phase to make 100 mL. When the procedure is run with 20 μL of this solution under the above operating conditions, 4-chlorobenzoic acid, butyl parahydroxybenzoate and indometacin are eluted in this order with the resolution between the peaks of 4-chlorobenzoic acid and butyl parahydroxybenzoate being not less than 2.0 and between the peaks of parahydroxybenzoate and indometacin being not less than 5.

System repeatability: When the test is repeated 6 times with 20 μL of the standard solution under the above operating conditions, the relative standard deviation of the ratios of the peak area of indometacin to that of the internal standard is not more than 1.0%.

Containers and storage Containers—Well-closed containers.

Storage—Light-resistant, and in a cold place.

Influenza HA Vaccine

インフルエンザ HA ワクチン

Influenza HA Vaccine is a liquid for injection containing hemagglutinin of influenza virus.

It conforms to the requirements of Influenza HA Vaccine in the Minimum Requirements for Biological Products.

Description Influenza HA Vaccine is a clear liquid or a slightly whitish turbid liquid.

Insulin Human (Genetical Recombination)

インスリン ヒト (遺伝子組換え)

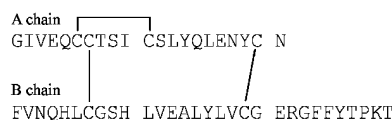

$\text{C}_{257}\text{H}_{383}\text{N}_{65}\text{O}_{77}\text{S}_6$: 5807.57 (two chains)

A chain $\text{C}_{99}\text{H}_{153}\text{N}_{25}\text{O}_{35}\text{S}_4$: 2381.68

B chain $\text{C}_{158}\text{H}_{234}\text{N}_{40}\text{O}_{42}\text{S}_2$: 3429.92

[11061-68-0]

Insulin Human (Genetical Recombination) is a recombinant human insulin. It is a peptide composed of A chain consisting of 21 amino acid residues and B chain consisting of 30 amino acid residues.

It contains not less than 27.5 Insulin Units per mg, calculated on the dried basis.

Description Insulin Human (Genetical Recombination) occurs as a white powder.

It is practically insoluble in water and in ethanol (95).

It dissolves in 0.01 mol/L hydrochloric acid TS and in sodium hydroxide TS with decomposition.

It is hygroscopic.

Identification Weigh accurately a suitable amount of Insulin Human (Genetical Recombination), and dissolve in 0.01 mol/L hydrochloric acid TS to make a solution so that each mL contains 2.0 mg. Transfer 500 μL of this solution into a clean test tube, add 2.0 mL of HEPES buffer solution (pH 7.5) and 400 μL of V8-protease TS, incubate at 25°C for 6 hours, then add 2.9 mL of ammonium sulfate buffer solution to stop the reaction, and use this solution as the sample solution. Separately, proceed with Insulin Human RS in the same manner as above, and use this solution as the standard solution. Perform the test with 50 μL each of the sample solution and standard solution as directed under Liquid Chromatography <2.01> according to the following conditions, and compare the chromatograms obtained from these solutions: a similar peak is observed at the same retention time in the both chromatograms.

Operating conditions—

Detector: An ultraviolet absorption photometer (wavelength: 214 nm).

Column: A stainless steel column 4.6 mm in inside diameter and 10 cm in length, packed with octadecylsilanized silica gel for liquid chromatography (3 μm in particle diameter).

Column temperature: A constant temperature of about 40°C.

Mobile phase A: A mixture of water, ammonium sulfate buffer solution and acetonitrile (7:2:1).

Mobile phase B: A mixture of water, acetonitrile and ammonium sulfate buffer solution (2:2:1).

Flowing of mobile phase: Change the mixing ratio of the mobile phase A and B linearly from 9:1 to 3:7 in 60 minutes after sample injection, further change to 0:10 linearly in 5 minutes, and then flow the mobile phase B only for 5 minutes.

Flow rate: 1.0 mL per minute.

System suitability—

System performance: When the procedure is run with 50 μL of the standard solution under the above operating con-

ditions, the symmetry factor of the two larger peaks which appear next to the first peak just after the solvent peak are not more than 1.5 respectively, and the resolution between these peaks is not less than 3.4.

Purity (1) Related substances—Perform this procedure rapidly. Dissolve 7.5 mg of Insulin Human (Genetical Recombination) in 2 mL of 0.01 mol/L hydrochloric acid TS, and use this solution as the sample solution. Perform the test with 20 μ L of the sample solution as directed under Liquid Chromatography <2.01> according to the following conditions, and determine the peak area of human insulin, A_1 , the peak area of the desamido substance having the relative retention time of about 1.3 to human insulin, A_D , and the total area of the peaks other than the solvent peak, A_T : the amounts of the desamido substance and related substances other than the desamido substance are not more than 2.0%, respectively. Previously, perform the test with 0.01 mol/L hydrochloric acid TS in the same manner to confirm the solvent peak.

Amount (%) of the desamido substance = $A_D/A_T \times 100$

Amount (%) of related substances other than the desamido substance
= $\{[A_T - (A_1 + A_D)]/A_T\} \times 100$

Operating conditions—

Detector: An ultraviolet absorption photometer (wavelength: 214 nm).

Column: A stainless steel column 4.6 mm in inside diameter and 25 cm in length, packed with octadecylsilanized silica gel for liquid chromatography (5 μ m in particle diameter).

Column temperature: A constant temperature of about 40°C.

Mobile phase A: A mixture of phosphoric acid-sodium sulfate buffer solution (pH 2.3) and acetonitrile for liquid chromatography (41:9).

Mobile phase B: A mixture of phosphoric acid-sodium sulfate buffer solution (pH 2.3) and acetonitrile for liquid chromatography (1:1).

Flowing of mobile phase: Flow a mixture of the mobile phase A and B (78:22) for 36 minutes before and after the sample injection, then change the mixing ratio to 33:67 linearly in 25 minutes, and maintain this ratio for 6 minutes. Then flow the first mixture (78:22) for the next 15 minutes. Adjust the mixing ratio of the first mixture so that the retention time of human insulin is about 25 minutes.

Flow rate: 1.0 mL per minute.

Time span of measurement: For about 75 minutes after the sample is injected.

System suitability—

Test for required detectability: Confirm that the peak height of the desamido substance obtained with 20 μ L of human insulin desamido substance-containing TS is between 30% and 70% of the full scale.

System performance: When the procedure is run with 20 μ L of human insulin desamido substance-containing TS under the above operating conditions, human insulin and human insulin desamido substance are eluted in this order with the resolution between these peaks being not less than 2.0, and the symmetry factor of the peak of human insulin is not more than 1.8.

(2) High-molecular mass proteins—Dissolve 4 mg of Insulin Human (Genetical Recombination) in 1 mL of 0.01 mol/L hydrochloric acid TS. Perform the test with 100 μ L of this solution as directed under Liquid Chromatography <2.01> according to the following conditions, and calculate each peak area: the total of areas of the peaks having smaller

retention time than human insulin is not more than 1.0% of the total area of all peaks.

Operating conditions—

Detector: An ultraviolet absorption photometer (wavelength: 276 nm).

Column: A stainless steel column 7.5 mm in inside diameter and 30 cm in length, packed with hydrophilic silica gel for liquid chromatography.

Column temperature: A constant temperature of about 25°C.

Mobile phase: A mixture of a solution of L-arginine (1 in 1000), acetonitrile and acetic acid (100) (13:4:3).

Flow rate: Adjust so that the retention time of human insulin is about 20 minutes.

Time span of measurement: Until the peak of human insulin monomer has appeared.

System suitability—

Test for required detectability: Confirm that the peak height of the dimer obtained with 100 μ L of human insulin dimer-containing TS is between 10% and 50% of the full scale.

System performance: When the procedure is run with 100 μ L of human insulin dimer-containing TS under the above operating conditions, polymer, dimer and monomer are eluted in this order, and the ratio, H_1/H_2 , of the peak height of the dimer H_1 to the height of the bottom between the peaks of the dimer and the monomer H_2 is not less than 2.0.

(3) Product related impurities—Being specified separately when the drug is granted approval based on the Law.

(4) Process related impurities—Being specified separately when the drug is granted approval based on the Law.

Loss on drying <2.41> Not more than 10.0% (0.2 g, 105°C, 24 hours).

Bacterial endotoxins <4.01> Less than 10 EU/mg.

Zinc content Weigh accurately about 50 mg of Insulin Human (Genetical Recombination), and dissolve in 0.01 mol/L hydrochloric acid TS to make exactly 25 mL. If necessary, dilute with 0.01 mol/L hydrochloric acid TS to make a solution so that each mL contains between 0.4 μ g and 1.6 μ g of zinc (Zn: 65.38), and use this solution as the sample solution. Separately, take exactly a suitable amount of Standard Zinc Solution for Atomic Absorption Spectrophotometry, dilute with 0.01 mol/L hydrochloric acid TS to make solutions containing 0.40 μ g, 0.80 μ g, 1.20 μ g and 1.60 μ g of zinc (Zn: 65.38) in each mL, respectively, and use these solutions as the standard solutions. Perform the test with the sample solution and standard solutions as directed under Atomic Absorption Spectrophotometry <2.23>, and calculate the amount of zinc (Zn: 65.38) in the sample solution by using a calibration curve obtained from the absorbances of the standard solutions: not more than 1.0%, calculated on the dried basis.

Gas: Combustible gas—Acetylene.

Supporting gas—Air.

Lamp: Zinc hollow cathode lamp.

Wavelength: 213.9 nm.

Assay Perform this procedure quickly. Weigh accurately about 7.5 mg of Insulin Human (Genetical Recombination), dissolve in 0.01 mol/L hydrochloric acid TS to make exactly 5 mL, and use this solution as the sample solution. Separately, weigh accurately a suitable amount of Insulin Human RS, dissolve exactly in 0.01 mol/L hydrochloric acid TS to make a solution so that each mL contains about 40 Insulin Units, and use this solution as the standard solution. Perform the test with exactly 20 μ L each of the sample solution

and standard solution as directed under Liquid Chromatography <2.01> according to the following conditions, and determine the peak areas of human insulin, A_{TI} and A_{SI} , and the peak areas of the desamido substance having the relative retention time of 1.3 to human insulin, A_{TD} and A_{SD} , respectively, of these solutions.

$$\begin{aligned} & \text{Amount (Insulin Unit/mg) of human insulin} \\ & (C_{257}H_{383}N_{65}O_{77}S_6) \\ & = (M_S \times F)/D \times (A_{TI} + A_{TD})/(A_{SI} + A_{SD}) \times 5/M_T \end{aligned}$$

F : Labeled unit (Insulin Unit/mg) of Insulin Human RS
 D : Volume (mL) of 0.01 mol/L hydrochloric acid TS used to dissolve the reference standard

M_T : Amount (mg) of Insulin Human (Genetical Recombination) taken, calculated on the dried basis

M_S : Amount (mg) of Insulin Human RS taken

Operating conditions—

Detector: An ultraviolet absorption photometer (wavelength: 214 nm).

Column: A stainless steel column 4.6 mm in inside diameter and 15 cm in length, packed with octadecylsilanized silica gel for liquid chromatography (5 μ m in particle diameter).

Column temperature: A constant temperature of about 40°C.

Mobile phase: A mixture of phosphoric acid-sodium sulfate buffer solution (pH 2.3) and acetonitrile for liquid chromatography (3:1). Adjust the mixing ratio of the component of the mobile phase so that the retention time of human insulin is between 10 minutes and 17 minutes.

Flow rate: 1.0 mL per minute.

System suitability—

System performance: When the procedure is run with 20 μ L of human insulin desamido substance-containing TS under the above operating conditions, human insulin and human insulin desamido substance are eluted in this order with the resolution between these peaks being not less than 2.0, and the symmetry factor of the peak of human insulin is not more than 1.8.

System repeatability: When the test is repeated 6 times with 20 μ L of the standard solution under the above operating conditions, the relative standard deviation of the peak areas of human insulin is not more than 1.6%.

Containers and storage Containers—Tight containers.

Storage—Not exceeding -20°C .

Insulin Human (Genetical Recombination) Injection

インスリン ヒト(遺伝子組換え)注射液

Insulin Human (Genetical Recombination) Injection is an aqueous injection.

It contains not less than 95.0% and not more than 105.0% of the labeled Insulin Unit of insulin human (genetical recombination) ($C_{257}H_{383}N_{65}O_{77}S_6$; 5807.57).

Method of preparation Prepare as directed under Injections, with Insulin Human (Genetical Recombination) suspended in Water for Injection then dissolved by addition of Hydrochloric Acid or Sodium Hydroxide.

Description Insulin Human (Genetical Recombination) Injection occurs as a clear, colorless liquid, and slightly a fine precipitate may be observable upon storage.

Identification Insulin Human (Genetical Recombination) Injection forms a precipitate when adjusted to pH 5.3 – 5.5 by addition of dilute hydrochloric acid, and the precipitate disappears when adjusted to pH 2.5 – 3.5 by further addition of the acid.

Osmotic pressure ratio Being specified separately when the drug is granted approval based on the Law.

pH Being specified separately when the drug is granted approval based on the Law.

Purity (1) Desamido substance—Perform the test with 20 μ L of the sample solution obtained in the Assay as directed under Liquid Chromatography <2.01> according to the following conditions. Determine each peak area by the automatic integration method, and calculate their amounts by the area percentage method: the amount of the peak, having the relative retention time of about 1.3 to human insulin, is not more than 1.5%.

Operating conditions—

Proceed as directed in the operating conditions in the Assay under Insulin Human (Genetical Recombination).

System suitability—

System performance: Proceed as directed in the system suitability in the Assay under Insulin Human (Genetical Recombination).

Test for required detectability: Pipet 1 mL of the sample solution, and add 0.01 mol/L hydrochloric acid TS to make exactly 50 mL. Confirm that the peak area of human insulin obtained with 20 μ L of this solution is equivalent to 1.4 to 2.6% of that with 20 μ L of the sample solution.

System repeatability: Dissolve Insulin Human RS in 0.01 mol/L hydrochloric acid TS so that each mL contains about 4 Insulin Units. When the test is repeated 6 times with 20 μ L of this solution under the above operating conditions, the relative standard deviation of the peak area of human insulin is not more than 2.0%.

(2) High-molecular mass proteins—For each mL of Insulin Human (Genetical Recombination) Injection add 4 μ L of 6 mol/L hydrochloric acid TS, and use this solution as the sample solution. Perform the test with 100 μ L of the sample solution as directed under Liquid Chromatography <2.01> according to the following conditions. Determine each peak area by the automatic integration method, and calculate the amount of them by the area percentage method: the total amount of the peaks other than human insulin is not more than 2.0%.

Operating conditions—

Detector, column temperature, mobile phase, and flow rate: Proceed as directed in the operating conditions in the Purity (2) under Insulin Human (Genetical Recombination).

Column: A stainless steel column 7.8 mm in inside diameter and 30 cm in length, packed with hydrophilic silica gel for liquid chromatography.

Time span of measurement: From the retention time corresponding to the exclusion volume of the size-exclusion column to the completion of the elution of human insulin.

System suitability—

System performance: Proceed as directed in the system suitability in the Purity (2) under Insulin Human (Genetical Recombination).

Test for required detectability: Pipet 1 mL of the sample solution, and add 0.01 mol/L hydrochloric acid TS to make exactly 50 mL. Confirm that the peak area of human insulin obtained with 100 μ L of this solution is equivalent to 1.4 to 2.6% of that with 100 μ L of the sample solution.

Bacterial endotoxins <4.01> Less than 0.80 EU/Insulin

Unit. Apply to the preparations intended for intravenous administration.

Extractable volume <6.05> It meets the requirement.

Foreign insoluble matter <6.06> Perform the test according to Method1: it meets the requirement.

Insoluble particulate matter <6.07> It meets the requirement.

Sterility <4.06> Perform the test according to the Membrane filtration method: it meets the requirement.

Zinc content To an exact volume of Insulin Human (Genetical Recombination) Injection, equivalent to 300 Insulin Units, add 0.01 mol/L hydrochloric acid TS to make exactly 50 mL. If necessary, further dilute with 0.01 mol/L hydrochloric acid TS to make exactly 100 mL, and use this solution as the sample solution. Separately, take exactly a suitable amount of Standard Zinc Solution for Atomic Absorption Spectrophotometry, dilute with 0.01 mol/L hydrochloric acid TS to make three solutions containing 0.20 μg , 0.60 μg and 1.20 μg of zinc (Zn: 65.38) in each mL, respectively, and use these solutions as the standard solutions. Perform the test with the sample solution and standard solutions as directed under Atomic Absorption Spectrophotometry <2.23> according to the following conditions, using the 0.01 mol/L hydrochloric acid TS as the blank, and calculate the amount of zinc in the sample solution by using a calibration curve obtained from the absorbances of the standard solutions: 10 – 40 μg of zinc (Zn: 65.38) per 100 Insulin Units.

Gas: Combustible gas—Acetylene.

Supporting gas—Air.

Lamp: Zinc hollow cathode lamp.

Wavelength: 213.9 nm.

Assay To exactly 10 mL of Insulin Human (Genetical Recombination) Injection add exactly 40 μL of 6 mol/L hydrochloric acid TS. Pipet 2 mL of this solution, add 0.01 mol/L hydrochloric acid TS to make exactly 5 mL, and use this solution as the sample solution. Then, proceed as directed in the Assay under Insulin Human (Genetical Recombination).

Amount (Insulin Unit) of human insulin ($\text{C}_{257}\text{H}_{383}\text{N}_{65}\text{O}_{77}\text{S}_6$) in 1 mL

$$= M_S \times F/D \times (A_{T1} + A_{TD}) / (A_{S1} + A_{SD}) \times 1.004 \times 5/2$$

M_S : Amount (mg) of Insulin Human RS taken

F : Labeled unit (Insulin Unit/mg) of Insulin Human RS

D : Volume (mL) of 0.01 mol/L hydrochloric acid TS used to dissolve Insulin Human RS

Containers and storage Containers—Hermetic containers.

Storage—Light-resistant, at a temperature of 2 – 8°C avoiding freezing.

Isophane Insulin Human (Genetical Recombination) Injectable Aqueous Suspension

イソフェンインスリン ヒト(遺伝子組換え)水性懸濁注射液

Isophane Insulin Human (Genetical Recombination) Injectable Aqueous Suspension is an aqueous suspension for injection.

It contains not less than 95.0% and not more than 105.0% of the labeled Insulin Unit of insulin human

(genetical recombination) ($\text{C}_{257}\text{H}_{383}\text{N}_{65}\text{O}_{77}\text{S}_6$; 5807.57). It contains not less than 10 μg and not more than 40 μg of zinc (Zn: 65.38) per the labeled 100 Insulin Units.

Method of preparation Prepare as directed under Injections, with Insulin Human (Genetical Recombination) and Protamine Sulfate.

Description Isophane Insulin Human (Genetical Recombination) Injectable Aqueous Suspension is a white aqueous suspension. When allowed to stand, it separates into a white precipitate and colorless supernatant liquid, and the precipitate returns to the suspension state on gentle shaking.

When it is examined microscopically, the precipitate mostly consists of fine, oblong crystals of 1 to 30 μm in major axis, and does not contain amorphous substances or large aggregates.

Identification Adjust Isophane Insulin Human (Genetical Recombination) Injectable Aqueous Suspension to pH between 2.5 and 3.0 with dilute hydrochloric acid: the precipitate dissolves, and the solution is clear and colorless.

pH Being specified separately when the drug is granted approval based on the Law.

Purity (1) Desamido substance—Perform the test with 20 μL of the sample solution obtained in the Assay (1) as directed under Liquid Chromatography <2.01> according to the following conditions. Determine each peak area by the automatic integration method, and calculate the amount of them by the area percentage method: the amount of the peak, having the relative retention time of about 1.3 to insulin human, is not more than 1.5%.

Operating conditions—

Proceed as directed in the operating conditions in the Assay (1).

System suitability—

System performance: Proceed as directed in the system suitability in the Assay (1).

Test for required detectability: Pipet 1 mL of the sample solution, add 0.01 mol/L hydrochloric acid TS to make exactly 50 mL. Confirm that the peak area of insulin human obtained with 20 μL of this solution is equivalent to 1.4 to 2.6% of that with 20 μL of the sample solution.

System repeatability: Dissolve Insulin Human RS in 0.01 mol/L hydrochloric acid TS so that each mL contains about 4 Insulin Units. When the test is repeated 6 times with 20 μL of this solution under the above operating conditions, the relative standard deviation of the peak area of insulin human is not more than 2.0%.

(2) Dissolved insulin human—Centrifuge Isophane Insulin Human (Genetical Recombination) Injectable Aqueous Suspension, and use the supernatant liquid as the sample solution. Separately, dissolve exactly Insulin Human RS in 0.01 mol/L hydrochloric acid TS to make a solution so that each mL contains about 1.0 Insulin Units, and use this solution as the standard solution. Perform the test with exactly 20 μL each of the sample solution and standard solution as directed under Liquid Chromatography <2.01> according to the following conditions. Determine the peak areas, A_T and A_S , of insulin human by the automatic integration method, and calculate the amount of dissolved insulin human by the following equation: not more than 0.5 Insulin Units per mL.

$$\begin{aligned} & \text{Amount (mg) of dissolved insulin human} \\ & \text{(Insulin Unit /mL)} \\ & = (M_S \times F)/D \times A_T/A_S \end{aligned}$$

M_S : Amount (mg) of Insulin Human RS taken

F: Labeled unit (Insulin Unit /mg) of Insulin Human RS
D: Volume (mL) of 0.01 mol/L hydrochloric acid TS used to dissolve Insulin Human RS

Operating conditions—

Proceed as directed in the operating conditions in the Assay (1).

System suitability—

System performance: When the procedure is run with 20 μ L of insulin human desamido substance-containing TS under the above operating conditions, insulin human and insulin human desamido substance are eluted in this order with the resolution between these peaks being not less than 2.0, and the symmetry factor of the peak of insulin human is not more than 1.6.

System repeatability: When the test is repeated 4 times with 20 μ L of the standard solution under the above operating conditions, the relative standard deviation of the peak area of insulin human is not more than 6.0%.

(3) High-molecular mass protein—Take a suitable volume of gently shaken Isophane Insulin Human (Genetical Recombination) Injectable Aqueous Suspension, add 4 μ L of 6 mol/L hydrochloric acid TS for each mL of the suspension, and mix until the solution becomes clear. Perform the test with 100 μ L of this solution as directed under Liquid Chromatography <2.01> according to the following conditions. Determine each peak area by the automatic integration method, and calculate the amount of them by the area percentage method: the total amount of the peaks other than insulin human is not more than 2.5%.

Operating conditions—

Detector, column temperature, mobile phase and flow rate: Proceed as directed in the operating conditions in the Purity (2) under Insulin Human (Genetical Recombination).

Column: A stainless steel column 7.8 mm in inside diameter and 30 cm in length, packed with hydrophilic silica gel for liquid chromatography.

Time span of measurement: From the retention time corresponding to the exclusion volume of the size-exclusion column to the completion of the elution of insulin human.

System suitability—

System performance: Proceed as directed in the system suitability in the Purity (2) under Insulin Human (Genetical Recombination).

Test for required detectability: Pipet 1 mL of the sample solution, and add 0.01 mol/L hydrochloric acid TS to make exactly 50 mL. Confirm that the peak area of insulin human obtained with 100 μ L of this solution is equivalent to 1.4 to 2.6% of that with 100 μ L of the sample solution.

Extractable volume <6.05> It meets the requirement.

Foreign insoluble matter <6.06> Perform the test according to Method 1: it meets the requirement.

Sterility <4.06> Perform the test according to the Membrane filtration method: it meets the requirement.

Assay (1) Insulin human—Pipet 10 mL of gently shaken Isophane Insulin Human (Genetical Recombination) Injectable Aqueous Suspension, and add exactly 40 μ L of 6 mol/L hydrochloric acid TS. Pipet 2 mL of this solution, add 0.01 mol/L hydrochloric acid TS to make exactly 5 mL, and use this solution as the sample solution. Then, proceed as directed in the Assay under Insulin Human (Genetical Recombination).

Amount (Insulin Unit) of insulin human ($C_{257}H_{383}N_{65}O_{77}S_6$) in 1 mL

$$= (M_S \times F)/D \times (A_{TI} + A_{TD})/(A_{SI} + A_{SD}) \times 1.004 \times 5/2$$

M_S: Amount (mg) of Insulin Human RS taken

F: Labeled unit (Insulin Unit /mg) of Insulin Human RS

D: Volume (mL) of 0.01 mol/L hydrochloric acid TS used to dissolve Insulin Human RS

(2) Zinc—Pipet a volume of gently shaken Isophane Insulin Human (Genetical Recombination) Injectable Aqueous Suspension, equivalent to 300 Insulin Units, and add 0.01 mol/L hydrochloric acid TS to make exactly 50 mL. If necessary, further add 0.01 mol/L hydrochloric acid TS to make exactly 100 mL, and use this solution as the sample solution. Separately, pipet a suitable volume of Standard Zinc Solution for Atomic Absorption Spectroscopy, dilute with 0.01 mol/L hydrochloric acid TS to make three solutions containing 0.20 μ g, 0.60 μ g and 1.20 μ g of zinc (Zn: 65.38) in each mL, respectively, and use these solutions as the standard solutions. Perform the test with the sample solution and standard solutions as directed under Atomic Absorption Spectroscopy <2.23> according to the following conditions, using 0.01 mol/L hydrochloric acid TS as the blank, and calculate the content of zinc in the sample solution by using the calibration curve obtained from the absorbances of the standard solutions.

Gas: Combustible gas—Acetylene.

Supporting gas—Air.

Lamp: Zinc hollow cathode lamp.

Wavelength: 213.9 nm.

Containers and storage Containers—Hermetic containers.

Storage—Light-resistant, at a temperature between 2°C and 8°C avoiding freezing.

Biphasic Isophane Insulin Human (Genetical Recombination) Injectable Aqueous Suspension

二相性イソフェンインスリン ヒト(遺伝子組換え)水性懸濁注射液

Biphasic Isophane Insulin Human (Genetical Recombination) Injectable Aqueous Suspension is an aqueous suspension for injection.

It contains not less than 95.0% and not more than 105.0% of the labeled Insulin Unit of insulin human (genetical recombination) ($C_{257}H_{383}N_{65}O_{77}S_6$: 5807.57). It contains not less than 10 μ g and not more than 40 μ g of zinc (Zn: 65.38) per the labeled 100 Insulin Units.

Method of preparation Prepare as directed under Injections, with Insulin Human (Genetical Recombination) Injection and Isophane Insulin Human (Genetical Recombination) Injectable Aqueous Suspension.

Description Biphasic Isophane Insulin Human (Genetical Recombination) Injectable Aqueous Suspension is a white aqueous suspension. When allowed to stand, it separates into a white precipitate and colorless supernatant liquid, and the precipitate returns to the suspension state on gentle shaking.

When it is examined microscopically, the precipitate mostly consists of fine, oblong crystals of 1 to 30 μ m in major

axis, and does not contain amorphous substances or large aggregates.

Identification Adjust Biphasic Isophane Insulin Human (Genetical Recombination) Injectable Aqueous Suspension to pH between 2.5 and 3.0 with dilute hydrochloric acid: the precipitate dissolves, and the solution is clear and colorless.

pH Being specified separately when the drug is granted approval based on the Law.

Purity (1) Desamido substance—Perform the test with 20 μ L of the sample solution obtained in the Assay (1) as directed under Liquid Chromatography <2.01> according to the following conditions. Determine each peak area by the automatic integration method, and calculate the amount of them by the area percentage method: the amount of the peak, having the relative retention time of about 1.3 to insulin human, is not more than 1.5%.

Operating conditions—

Proceed as directed in the operating conditions in the Assay (1).

System suitability—

System performance: Proceed as directed in the system suitability in the Assay (1).

Test for required detectability: Pipet 1 mL of the sample solution, add 0.01 mol/L hydrochloric acid TS to make exactly 50 mL. Confirm that the peak area of insulin human obtained with 20 μ L of this solution is equivalent to 1.4 to 2.6% of that with 20 μ L of the sample solution.

System repeatability: Dissolve Insulin Human RS in 0.01 mol/L hydrochloric acid TS so that each mL contains about 4 Insulin Units. When the test is repeated 6 times with 20 μ L of this solution under the above operating conditions, the relative standard deviation of the peak area of insulin human is not more than 2.0%.

(2) High-molecular mass protein—Take a suitable volume of gently shaken Biphasic Isophane Insulin Human (Genetical Recombination) Injectable Aqueous Suspension, add 4 μ L of 6 mol/L hydrochloric acid TS for each mL of the suspension, and mix until the solution becomes clear. Perform the test with 100 μ L of this solution as directed under Liquid Chromatography <2.01> according to the following conditions. Determine each peak area by the automatic integration method, and calculate the amount of them by the area percentage method: the total amount of the peaks other than insulin human is not more than 2.0%.

Operating conditions—

Detector, column temperature, mobile phase and flow rate: Proceed as directed in the operating conditions in the Purity (2) under Insulin Human (Genetical Recombination).

Column: A stainless steel column 7.8 mm in inside diameter and 30 cm in length, packed with hydrophilic silica gel for liquid chromatography.

Time span of measurement: From the retention time corresponding to the exclusion volume of the size-exclusion column to the completion of the elution of insulin human.

System suitability—

System performance: Proceed as directed in the system suitability in the Purity (2) under Insulin Human (Genetical Recombination).

Test for required detectability: Pipet 1 mL of the sample solution, and add 0.01 mol/L hydrochloric acid TS to make exactly 50 mL. Confirm that the peak area of insulin human obtained with 100 μ L of this solution is equivalent to 1.4 to 2.6% of that with 100 μ L of the sample solution.

Extractable volume <6.05> It meets the requirement.

Foreign insoluble matter <6.06> Perform the test according to Method 1: it meets the requirement.

Sterility <4.06> Perform the test according to the Membrane filtration method: it meets the requirement.

Soluble Insulin Human Being specified separately when the drug is granted approval based on the Law.

Assay (1) Insulin human—Pipet 10 mL of gently shaken Biphasic Isophane Insulin Human (Genetical Recombination) Injectable Aqueous Suspension, and add exactly 40 μ L of 6 mol/L hydrochloric acid TS. Pipet 2 mL of this solution, add 0.01 mol/L hydrochloric acid TS to make exactly 5 mL, and use this solution as the sample solution. Then, proceed as directed in the Assay under Insulin Human (Genetical Recombination).

Amount (Insulin Unit) of insulin human ($C_{257}H_{383}N_{65}O_{77}S_6$) in 1 mL

$$= (M_S \times F) / D \times (A_{T1} + A_{TD}) / (A_{SI} + A_{SD}) \times 1.004 \times 5/2$$

M_S : Amount (mg) of Insulin Human RS taken

F : Labeled unit (Insulin Unit /mg) of Insulin Human RS

D : Volume (mL) of 0.01 mol/L hydrochloric acid TS used to dissolve Insulin Human RS

(2) Zinc—Pipet a volume of gently shaken Biphasic Isophane Insulin Human (Genetical Recombination) Injectable Aqueous Suspension, equivalent to 300 Insulin Units, and add 0.01 mol/L hydrochloric acid TS to make exactly 50 mL. If necessary, further add 0.01 mol/L hydrochloric acid TS to make exactly 100 mL, and use this solution as the sample solution. Separately, pipet a suitable volume of Standard Zinc Solution for Atomic Absorption Spectroscopy, dilute with 0.01 mol/L hydrochloric acid TS to make three solutions containing 0.20 μ g, 0.60 μ g and 1.20 μ g of zinc (Zn: 65.38) in each mL, respectively, and use these solutions as the standard solutions. Perform the test with the sample solution and standard solutions as directed under Atomic Absorption Spectroscopy <2.23> according to the following conditions, using 0.01 mol/L hydrochloric acid TS as the blank, and calculate the content of zinc in the sample solution by using the calibration curve obtained from the absorbances of the standard solutions.

Gas: Combustible gas—Acetylene.

Supporting gas—Air.

Lamp: Zinc hollow cathode lamp.

Wavelength: 213.9 nm.

Containers and storage Containers—Hermetic containers.

Storage—Light-resistant, at a temperature between 2°C and 8°C avoiding freezing.

Insulin Aspart (Genetical Recombination)

インスリン アスパルト (遺伝子組換え)



$C_{256}H_{381}N_{65}O_{79}S_6$: 5825.54 (two chains)

A chain $C_{99}H_{153}N_{25}O_{35}S_4$: 2381.68

B chain $C_{157}H_{232}N_{40}O_{44}S_2$: 3447.89

[116094-23-6]

Insulin Aspart (Genetical Recombination) is a recombinant human insulin analogue, in which proline residue at 28th of B chain is substituted with aspartic acid. It is a peptide composed of A chain consisting of 21 amino acid residues and B chain consisting of 30 amino acid residues.

It contains not less than 92.6% and not more than 109.5% of insulin aspart (genetical recombination) ($C_{256}H_{381}N_{65}O_{79}S_6$), calculated on the dried and residue on ignition-free basis.

0.0350 mg of Insulin Aspart (Genetical Recombination) is equivalent to 1 Insulin Unit.

Description Insulin Aspart (Genetical Recombination) occurs as a white powder.

It is practically insoluble in water and in ethanol (95).

It dissolves in 0.01 mol/L hydrochloric acid TS.

It is hygroscopic.

Identification Weigh a suitable amount of Insulin Aspart (Genetical Recombination), and dissolve in 0.01 mol/L hydrochloric acid TS to make a solution so that each mL contains 2.0 mg. Separately, dissolve Insulin Aspart RS in 0.01 mol/L hydrochloric acid TS to make a solution so that each mL contains 2.0 mg. Transfer 25 μ L each of these solutions into clean test tubes, add 100 μ L of HEPES buffer solution (pH 7.5) and 20 μ L of V8-protease TS, and allow to react at 25°C for 6 hours. Then add 145 μ L of ammonium sulfate buffer solution to stop the reaction, and use these solutions as the sample solution and the standard solution, respectively. Perform the test with exactly 50 μ L each of the sample solution and standard solution as directed under Liquid Chromatography <2.01> according to the following conditions, and compare the peak (peak 1) eluted just after the peak of the solvent and the succeeding three peaks (peaks 2, 3 and 4) with apparently higher peak height in the chromatograms obtained from these solutions: the similar peaks are observed at the same retention times.

Operating conditions—

Detector: An ultraviolet absorption photometer (wavelength: 214 nm).

Column: A stainless steel column 4.6 mm in inside diameter and 10 cm in length, packed with octadecylsilanized silica gel for liquid chromatography (not exceeding 5 μ m in particle diameter).

Column temperature: A constant temperature of about 40°C.

Mobile phase A: A mixture of water, ammonium sulfate buffer solution and acetonitrile for liquid chromatography (7:2:1).

Mobile phase B: A mixture of water, acetonitrile for liquid chromatography and ammonium sulfate buffer solution (2:2:1).

Flowing of mobile phase: Control the gradient by mixing the mobile phases A and B as directed in the following table.

Time after injection of sample (min)	Mobile phase A (vol%)	Mobile phase B (vol%)
0 - 60	90 → 30	10 → 70
60 - 65	30 → 0	70 → 100
65 - 70	0	100

Flow rate: 1 mL per minute.

System suitability—

System performance: When the procedure is run with 50 μ L of the standard solution under the above operating con-

ditions, the symmetry factors of the peaks 2 and 3 are not more than 1.5, respectively, and the resolution between these peaks is not less than 8.

Purity (1) Related substances—Perform the test with 10 μ L of the sample solution obtained in the Assay as directed under Liquid Chromatography <2.01> according to the following conditions. Determine each peak area by the automatic integration method, and calculate the amounts of them by the area percentage method: the amount of the peak of B28isoAsp insulin aspart, having the relative retention time of about 0.9 to insulin aspart, is not more than 0.3%, the total amount of the peak of A21Asp insulin aspart and B3Asp insulin aspart, having the relative retention times of about 1.3, and the peak of B3isoAsp insulin aspart, having the relative retention time of about 1.5, is not more than 1.0%, and the total amount of the peaks other than the peaks mentioned above is not more than 0.5%.

Operating conditions—

Detector, column, column temperature, mobile phase A, mobile phase B, flowing of mobile phase and flow rate: Proceed as directed in the operating conditions in the Assay.

Time span of measurement: From 4 minutes to 50 minutes after injection of the sample solution.

System suitability—

System performance and system repeatability: Proceed as directed in the system suitability in the Assay.

Test for required detectability: Pipet 5 mL of the solution for system suitability test obtained in the Assay, add 0.01 mol/L hydrochloric acid TS to make exactly 10 mL. Confirm that the area percentage of the peak of B28isoAsp insulin aspart obtained with 10 μ L of this solution is equivalent to 80 to 120% of that with 10 μ L of the solution for system suitability test.

(2) High-molecular proteins—Store the sample solution at a temperature between 2°C and 8°C, and use within 48 hours after preparation. Dissolve 4 mg of Insulin Aspart (Genetical Recombination) in 1 mL of 0.01 mol/L hydrochloric acid TS, and use this solution as the sample solution. Perform the test with 100 μ L of the sample solution as directed under Liquid Chromatography <2.01> according to the following conditions, determine each peak area by the automatic integration method, and calculate the amounts of them by the area percentage method: the total amount of the peaks other than insulin aspart is not more than 0.3%.

Operating conditions—

Detector: An ultraviolet absorption photometer (wavelength: 276 nm).

Column: A stainless steel column 7.8 mm in inside diameter and 30 cm in length, packed with hydrophilic silica gel for liquid chromatography (5 to 10 μ m in particle diameter).

Column temperature: A constant temperature of about 20°C.

Mobile phase: A mixture of a solution of L-arginine (1 in 1000), acetonitrile for liquid chromatography and acetic acid (100) (13:4:3).

Flow rate: 0.5 mL per minute.

Time span of measurement: From the retention time corresponding to the exclusion volume of the size-exclusion column to the completion of the elution of insulin aspart.

System suitability—

Test for required detectability: Allow Insulin Aspart (Genetic Recombination) to stand at ordinary temperature for about 10 days, which results in containing about 0.4% of high-molecular proteins, dissolve in 0.01 mol/L hydrochloride TS so that each mL contains about 4 mg of insulin aspart, and use this solution as the solution for system

suitability test. Store the solution for system suitability test at a temperature between 2°C and 8°C, and use within 7 days. Pipet 5 mL of the solution for system suitability test, and add 0.01 mol/L hydrochloric acid TS to make exactly 10 mL. Confirm that the area percentage of the peak of insulin aspart dimer obtained with 100 µL of this solution is equivalent to 80 to 120% of that with 100 µL of the solution for system suitability test.

System performance: When the procedure is run with 100 µL of the solution for system suitability test under the above operating conditions, insulin aspart polymer (retention time: 13 to 17 minutes), insulin aspart dimer (retention time: about 17.5 minutes) and insulin aspart (retention time: 18 to 20 minutes) are eluted in this order, and determine the peak height of the dimer and the height of the bottom between the peaks of the dimer and the monomer: the peak-valley ratio is not less than 2.0.

System repeatability: When the test is repeated 6 times with 100 µL of the solution for system suitability test under the above operating conditions, the relative standard deviation of the peak area of insulin aspart is not more than 2.0%.

(3) Host cell proteins—Being specified separately when the drug is granted approval based on the Law.

(4) Host cell DNA—Being specified separately when the drug is granted approval based on the Law.

Loss on drying <2.41> Not more than 10.0% (0.2 g, 105°C, 24 hours).

Residue on ignition <2.44> Not more than 6.0% (0.2 g).

Assay Store the sample solution and the standard solution at a temperature between 2°C and 8°C, use the sample solution within 24 hours after preparation, and use the standard solution within 48 hours after preparation. Weigh accurately a suitable amount of Insulin Aspart (Genetical Recombination), dissolve in 0.01 mol/L hydrochloric acid TS so that each mL contains 4.0 mg, and use this solution as the sample solution. Separately, dissolve Insulin Aspart RS in 0.01 mol/L hydrochloric acid TS so that each mL contains 4.0 mg, and use this solution as the standard solution. Perform the test with exactly 10 µL each of the sample solution and standard solution as directed under Liquid Chromatography <2.01> according to the following conditions, and determine the total areas, A_T and A_S , of the peak of B28isoAsp insulin aspart (relative retention time to insulin aspart: about 0.9), the peak of insulin aspart (retention time: 20 to 24 minutes), the peak of A21Asp insulin aspart and B3Asp insulin aspart (usually eluted together having the relative retention time of about 1.3) and the peak of B3isoAsp insulin aspart (relative retention time: about 1.5) in each solution.

$$\begin{aligned} \text{Amount (mg) of insulin aspart (C}_{256}\text{H}_{381}\text{N}_{65}\text{O}_{79}\text{S}_6) \\ = M_S \times A_T / A_S \end{aligned}$$

M_S : Total amount (mg) of insulin aspart, B28isoAsp insulin aspart, A21Asp insulin aspart and B3Asp insulin aspart, and B3isoAsp insulin aspart in 1 mL of the standard solution

Operating conditions—

Detector: An ultraviolet absorption photometer (wavelength: 214 nm).

Column: A stainless steel column 4.0 mm in inside diameter and 25 cm in length, packed with octadecylsilanized silica gel for liquid chromatography (not exceeding 5 µm in particle diameter).

Column temperature: A constant temperature of about 40°C.

Mobile phase A: Dissolve 142.0 g of anhydrous sodium sulfate in water, add 13.5 mL of phosphoric acid, and add water to make 5 L. Adjust to pH 3.6 with sodium hydroxide TS. To 4500 mL of this solution add 500 mL of acetonitrile for liquid chromatography.

Mobile phase B: A mixture of water and acetonitrile for liquid chromatography (1:1).

Flowing of mobile phase: Control the gradient by mixing the mobile phases A and B as directed in the following table.

Time after injection of sample (min)	Mobile phase A (vol%)	Mobile phase B (vol%)
0 – 35	58	42
35 – 40	58 → 20	42 → 80
40 – 45	20	80
45 – 46	20 → 58	80 → 42
46 – 60	58	42

Flow rate: 1 mL per minute.

System suitability—

System performance: Dissolve Insulin Aspart (Genetical Recombination) in 0.01 mol/L sodium dihydrogen phosphate TS (pH 7.5) so that each mL contains 8 mg, and allow to stand at ordinary temperature for 10 to 15 days. To 1 mL of this solution add 1 mL of 0.01 mol/L hydrochloric acid TS, allow to stand at ordinary temperature for 1 to 3 days, and use this solution as the solution for system suitability test. The solution for system suitability test contains 0.1 to 2.2% of B28isoAsp insulin aspart, and not less than 1% of B3Asp insulin aspart and A21Asp insulin aspart. Store the solution for system suitability test at a temperature between 2°C and 8°C, and use within 72 hours. When the procedure is run with 10 µL of the solution for system suitability test under the above operating conditions, B28isoAsp insulin aspart, insulin aspart, A21Asp insulin aspart and B3Asp insulin aspart, and B3isoAsp insulin aspart are eluted in this order with the resolution between the peak of insulin aspart and the peak of A21Asp insulin aspart and B3Asp insulin aspart being not less than 2.0.

System repeatability: When the test is repeated 5 times with 10 µL of the standard solution under the above operating conditions, the relative standard deviation of A_S is not more than 1.5%.

Containers and storage Containers—Tight containers.

Storage—Not exceeding –18°C.

Insulin Glargine (Genetical Recombination)

インスリン グラルギン(遺伝子組換え)

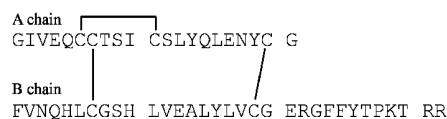

$C_{267}H_{404}N_{72}O_{78}S_6$: 6062.89 (two chains)

A chain $C_{97}H_{150}N_{24}O_{34}S_4$: 2324.63

B chain $C_{170}H_{258}N_{48}O_{44}S_2$: 3742.29

[160337-95-1]

Insulin Glargine (Genetical Recombination) is a recombinant human insulin analogue, being substitut-

ed asparagine residue with glycine residue at 21st of A chain and added two arginine residues at C-terminal of B chain. It is a peptide composed with A chain consisting of 21 amino acid residues and B chain consisting of 32 amino acid residues.

It contains not less than 94.0% and not more than 105.0% of insulin glargine (genetical recombination) ($C_{267}H_{404}N_{72}O_{78}S_6$), calculated on the anhydrous basis.

0.0364 mg of Insulin Glargine (Genetical Recombination) is equivalent to 1 Insulin Unit.

Description Insulin Glargine (Genetical Recombination) occurs as a white powder.

It is practically insoluble in water and in ethanol (99.5).

It is sparingly soluble in 0.01 mol/L hydrochloric acid TS.

It is hygroscopic.

It is gradually decomposed by light.

Identification Keep the sample solution and standard solution at 2 – 8°C. Weigh a suitable amount of Insulin Glargine (Genetical Recombination) and Insulin Glargine RS, and dissolve separately in 0.01 mol/L hydrochloric acid TS so that each mL contains 10.0 mg. Transfer 5 μ L of these solutions into clean test tubes, add 1 mL of 1 mol/L tris buffer solution (pH 7.5) and 100 μ L of a solution of V8 protease for insulin glargine in 1 mol/L tris buffer solution (pH 7.5) (20 units/mL), allow to react at 35 – 37°C for 3 hours, then add 2 μ L of phosphoric acid to stop the reaction, and use these solutions as the sample solution and the standard solution, respectively. Perform the test with exactly 50 μ L each of the sample solution and standard solution as directed under Liquid Chromatography <2.01> according to the following conditions, and compare the chromatograms obtained from these solutions: The similar peaks appear at the same retention times.

Operating conditions—

Detector: An ultraviolet absorption photometer (wavelength: 214 nm).

Column: A stainless steel column 3 mm in inside diameter and 12.5 cm in length, packed with octadecylsilanized silica gel for liquid chromatography (4 μ m in particle diameter). Column temperature: A constant temperature of about 35°C.

Mobile phase A: To 930 mL of a solution, prepared by dissolving 11.6 g of phosphoric acid and 42.1 g of sodium perchloric acid in 1600 mL of water, adjusting to pH 2.3 with triethylamine and adding water to make 2000 mL, add 70 mL of acetonitrile for liquid chromatography.

Mobile phase B: To 430 mL of a solution, prepared by dissolving 11.6 g of phosphoric acid and 42.1 g of sodium perchloric acid in 1600 mL of water, adjusting to pH 2.3 with triethylamine and adding water to make 2000 mL, add 570 mL of acetonitrile for liquid chromatography.

Flowing of mobile phase: Control the gradient by mixing the mobile phases A and B as follows.

Time after injection of sample (min)	Mobile phase A (vol%)	Mobile phase B (vol%)
0 – 30	90 → 20	10 → 80
30 – 35	20	80

Flow rate: 0.55 mL per minute.

System suitability—

System performance: When the procedure is run with 50 μ L of the standard solution under the above operating conditions, the symmetry factors of the two larger peaks, which

appear next to the first peak just after the solvent peak, are not more than 1.5, respectively, and the resolution between these peaks is not less than 3.4.

Purity (1) Related substances—Perform the test with 5 μ L of the sample solution obtained in the Assay as directed under Liquid Chromatography <2.01> according to the following conditions. Determine each peak area by the automatic integration method, and calculate the amount of these peaks by the area percentage method: the amount of the peak other than insulin glargine is not more than 0.4%, and the total amount of the peaks other than insulin glargine is not more than 1.0%.

Operating conditions—

Detector, column, column temperature, mobile phases A and B, flowing of mobile phase, and flow rate: Proceed as directed in the operating conditions in the Assay.

Time span of measurement: For 40 minutes after injection, beginning after the solvent peak.

System suitability—

Test for required detectability: Pipet 1 mL of the sample solution, add 0.01 mol/L hydrochloric acid TS to make exactly 100 mL, and use this solution as the solution for system suitability test. Pipet 1 mL of the solution for system suitability test, add 0.01 mol/L hydrochloric acid TS to make exactly 10 mL. Confirm that the peak area of insulin glargine obtained with 5 μ L of this solution is equivalent to 5 to 15% of that with 5 μ L of the solution for system suitability test.

System performance: When the procedure is run with 5 μ L of the standard solution obtained in the Assay under the above operating conditions, the number of theoretical plates and the symmetry factor of the peak of insulin glargine are not less than 20,000 and not more than 1.8, respectively.

System repeatability: When the test is repeated 6 times with 5 μ L of the standard solution obtained in the Assay under the above operating conditions, the relative standard deviation of the peak area of insulin glargine is not more than 2.0%.

(2) High-molecular mass proteins—Keep the sample solution at 2 – 8°C. Dissolve 15 mg of Insulin Glargine (Genetical Recombination) in 1.5 mL of 0.01 mol/L hydrochloric acid TS, add water to make 10 mL, and use this solution as the sample solution. Perform the test with 100 μ L of the sample solution as directed under Liquid Chromatography <2.01> according to the following conditions. Determine each peak area by the automatic integration method, and calculate the amount of them by the area percentage method: the total amount of the peaks other than insulin glargine is not more than 0.3%.

Operating conditions—

Detector: An ultraviolet absorption photometer (wavelength: 276 nm).

Column: Two stainless steel columns connected in series of 8 mm in inside diameter and 30 cm in length, packed with hydrophilic silica gel for liquid chromatography (5 μ m in particle diameter).

Column temperature: A constant temperature of about 25°C.

Mobile phase: To 400 mL of water add 300 mL of acetonitrile for liquid chromatography and 200 mL of acetic acid (100), adjust to pH 3.0 with ammonia solution (28), and add water to make 1000 mL.

Flow rate: Adjust so that the retention time of insulin glargine is about 35 minutes.

Time span of measurement: From the retention time corresponding to the exclusion volume of the size-exclusion

column to the completion of the elution of insulin glargine. *System suitability*—

Test for required detectability: To 1 mL of the sample solution add 0.01 mol/L hydrochloric acid TS to make 50 mL, and use this solution as the solution for system suitability test. Pipet 1 mL of the solution for system suitability test, add 0.01 mol/L hydrochloric acid TS to make exactly 10 mL. Confirm that the peak area of insulin glargine obtained with 100 μ L of this solution is equivalent to 5 to 15% of that with 100 μ L of the solution for system suitability test.

System performance: Heat 15 mg of Insulin Glargine (Genetical Recombination) at 100°C for 1.5–3 hours, then dissolve in 1.5 mL of 0.01 mol/L hydrochloric acid TS, and add water to make exactly 10 mL. When the procedure is run with 100 μ L of this solution under the above operating conditions, the high-molecular mass protein and insulin glargine are eluted in this order with the resolution between these peaks is not less than 1.5.

System repeatability: When the test is repeated 6 times with 100 μ L of the solution for system suitability test under the above operating conditions, the relative standard deviation of the peak area of insulin glargine is not more than 2.0%.

(3) Other product-related impurities—Being specified separately when the drug is granted approval based on the Law.

(4) Host cell proteins—Being specified separately when the drug is granted approval based on the Law.

(5) Host cell DNA—Being specified separately when the drug is granted approval based on the Law.

Water <2.48> Not more than 8.0% (90 mg, coulometric titration).

Bacterial endotoxins <4.01> Less than 10 EU/mg.

Zinc content Weigh accurately about 45 mg of Insulin Glargine (Genetical Recombination), dissolve in 0.01 mol/L hydrochloric acid TS to make exactly 50 mL. Pipet 10 mL of this solution, add 0.01 mol/L hydrochloric acid TS to make exactly 100 mL, and use this solution as the sample solution. Separately, take exactly a suitable amount of Standard Zinc Solution for Atomic Absorption Spectrophotometry, dilute with 0.01 mol/L hydrochloric acid TS to make three solutions containing 0.20 μ g, 0.40 μ g and 0.60 μ g of zinc (Zn: 65.38) in each mL, respectively, and use these solutions as the standard solutions. Perform the test with the sample solution and standard solutions as directed under Atomic Absorption Spectrophotometry <2.23> according to the following conditions, and calculate the amount of zinc in the sample solution using a calibration curve obtained from the absorbances of the standard solutions: not more than 0.80% of zinc (Zn: 65.38), calculated on the anhydrous basis.

Gas: Combustible gas—Acetylene.

Supporting gas—Air.

Lamp: Zinc hollow-cathode lamp.

Wavelength: 213.9 nm.

Assay Keep the sample solution and standard solution at 2–8°C. Weigh accurately about 15 mg of Insulin Glargine (Genetical Recombination), dissolve in 1.5 mL of 0.01 mol/L hydrochloric acid TS, add water to make exactly 10 mL, and use this solution as the sample solution. Separately, dissolve Insulin Glargine RS in 0.01 mol/L hydrochloric acid TS so that each mL contains about 10 mg of insulin glargine, then exactly dilute with water so that each mL contains about 1.5 mg of insulin glargine, and use this solution as the standard solution. Perform the test with exactly 5 μ L each of

the sample solution and standard solution as directed under Liquid Chromatography <2.01> according to the following conditions, and determine the peak areas, A_T and A_S , of insulin glargine in each solution.

$$\begin{aligned} &\text{Amount (mg) of insulin glargine (C}_{267}\text{H}_{404}\text{N}_{72}\text{O}_{78}\text{S}_6) \\ &= M_S \times A_T/A_S \end{aligned}$$

M_S : Amount (mg) of insulin glargine in 1 mL of the standard solution

Operating conditions—

Detector: An ultraviolet absorption photometer (wavelength: 214 nm).

Column: A stainless steel column 3 mm in inside diameter and 25 cm in length, packed with octadecylsilanized silica gel for liquid chromatography (4 μ m in particle diameter).

Column temperature: A constant temperature of about 35°C.

Mobile phase A: Dissolve 20.7 g of anhydrous sodium dihydrogen phosphate in 900 mL of water, adjust to pH 2.5 with phosphoric acid, and add water to make 1000 mL. To 250 mL of this solution add 250 mL of acetonitrile for liquid chromatography, dissolve 18.4 g of sodium chloride in this solution, and add water to make 1000 mL.

Mobile phase B: Dissolve 20.7 g of anhydrous sodium dihydrogen phosphate in 900 mL of water, adjust to pH 2.5 with phosphoric acid, and add water to make 1000 mL. To 250 mL of this solution add 650 mL of acetonitrile for liquid chromatography, dissolve 3.2 g of sodium chloride in this solution, and add water to make 1000 mL.

Flowing of mobile phase: Control the gradient by mixing the mobile phases A and B as directed in the following table.

Time after injection of sample (min)	Mobile phase A (vol%)	Mobile phase B (vol%)
0–20	96 → 83	4 → 17
20–30	83 → 63	17 → 37
30–40	63 → 96	37 → 4

Flow rate: 0.55 mL per minute (the retention time of insulin glargine is about 21 minutes).

System suitability—

System performance: When the procedure is run with 5 μ L of the standard solution under the above operating conditions, the number of theoretical plates and the symmetry factor of the peak of insulin glargine are not less than 20,000 and not more than 1.8, respectively.

System repeatability: When the test is repeated 6 times with 5 μ L of the standard solution under the above operating conditions, the relative standard deviation of the peak area of insulin glargine is not more than 2.0%.

Containers and storage Containers—Tight containers.

Storage—Not exceeding –15°C.

Insulin Glargine (Genetical Recombination) Injection

インスリン グラルギン(遺伝子組換え)注射液

Insulin Glargine (Genetical Recombination) Injection is an aqueous injection.

It contains not less than 95.0% and not more than 105.0% of the labeled Insulin Unit of insulin glargine

(genetical recombination) (C₂₆₇H₄₀₄N₇₂O₇₈S₆: 6062.89).

Method of preparation Prepare as directed under Injections, with Insulin Glargine (Genetical Recombination).

Description Insulin Glargine (Genetical Recombination) Injection occurs as a clear, colorless liquid.

Identification (1) Insulin Glargine (Genetical Recombination) Injection forms a precipitate when adjusted to pH 5.7 – 6.5 with dilute sodium hydroxide TS, and the precipitate disappears when adjusted to pH 3.5 – 4.5 with 0.1 mol/L hydrochloric acid TS.

(2) Perform the test with 5 μ L each of the sample solution and the standard solution obtained in the Assay as directed under Liquid Chromatography <2.01> according to the conditions described in the Assay: the retention times of the principal peaks obtained from the sample solution and standard solution are the same.

pH Being specified separately when the drug is granted approval based on the Law.

Purity (1) Related substances—Keep the sample solution at 2 – 8°C. Perform the test with 5 μ L of the sample solution obtained in the Assay as directed under Liquid Chromatography <2.01> according to the following conditions. Determine each peak area by the automatic integration method, and calculate their amounts by the area percentage method: the amount of the peak other than insulin glargine is not more than 0.5%, and the total amount of the peaks other than insulin glargine is not more than 2.0%.

Operating conditions—

Detector, column, column temperature, mobile phases A and B, flowing of mobile phase, and flow rate: Proceed as directed in the operating conditions in the Assay under Insulin Glargine (Genetical Recombination).

Time span of measurement: For 40 minutes after injection, beginning after the solvent peak.

System suitability—

Test for required detectability: Pipet 1 mL of the sample solution, add 0.01 mol/L hydrochloric acid TS to make exactly 100 mL, and use this solution as the solution for system suitability test. Pipet 1 mL of the solution for system suitability test, and add 0.01 mol/L hydrochloric acid TS to make exactly 10 mL. Confirm that the peak area of insulin glargine obtained with 5 μ L of this solution is equivalent to 5 to 15% of that with 5 μ L of the solution for system suitability test.

System performance: When the procedure is run with 5 μ L of the standard solution obtained in the Assay under the above operating conditions, the number of theoretical plates and the symmetry factor of the peak of insulin glargine are not less than 20,000 and not more than 1.8, respectively.

System repeatability: When the test is repeated 6 times with 5 μ L of the standard solution obtained in the Assay under the above operating conditions, the relative standard deviation of the peak area of insulin glargine is not more than 2.0%.

(2) High-molecular mass proteins—To a suitable amount of Insulin Glargine (Genetical Recombination) Injection add water so that each mL contains 40 Insulin Units, and use this solution as the sample solution. Then, proceed as directed in the Purity (2) under Insulin Glargine (Genetical Recombination).

Extractable volume <6.05> It meets the requirement.

Foreign insoluble matter <6.06> Perform the test according to Method 1: it meets the requirement.

Insoluble particulate matter <6.07> It meets the requirement.

Sterility <4.06> Perform the test according to the Membrane filtration method: it meets the requirement.

Zinc content Being specified separately when the drug is granted approval based on the Law.

Assay To a suitable amount of Insulin Glargine (Genetical Recombination) Injection add exactly water so that each mL contains 40 Insulin Units, and use this solution as the sample solution. Then, proceed as directed in the Assay under Insulin Glargine (Genetical Recombination).

Amount (Insulin Unit) of insulin glargine (C₂₆₇H₄₀₄N₇₂O₇₈S₆) in 1 mL

$$= M_S \times A_T/A_S \times d \times 1/0.0364$$

M_S : Amount (mg) of insulin glargine in 1 mL of the standard solution

d : Dilution factor of the sample solution

0.0364: Mass (mg) of insulin glargine equivalent to 1 Insulin Unit

Containers and storage Containers—Hermetic containers.

Storage—Light-resistant, at a temperature of 2 – 8°C avoiding freezing.

Interferon Alfa (NAMALWA)

インターフェロン アルファ (NAMALWA)

Interferon Alfa (NAMALWA) is essentially a human interferon alfa, which is a glycoprotein (molecular mass: 17,000 – 30,000) produced by the human lymphoblast NAMALWA cell induced by Sendai virus. It is an aqueous solution. It possesses the antiviral activity.

It contains not less than 50 μ g and not more than 500 μ g of protein per mL, and not less than 1.0×10^8 Units per mg of the protein.

Description Interferon Alfa (NAMALWA) occurs as a clear and colorless liquid.

Identification (1) To Interferon Alfa (NAMALWA) add Eagle's minimum essential medium containing bovine serum so that each mL contains 5000 Units, and use this solution as the sample stock solution. To anti-interferon alfa antiserum add an amount of Eagle's minimum essential medium containing bovine serum so that each mL contains an amount of anti-interferon alfa antiserum which neutralizes 10,000 Units of interferon alfa. To this solution add an equal volume of the sample stock solution, stir, and use this solution as the sample solution. Separately, to the sample stock solution add an equal volume of Eagle's minimum essential medium containing bovine serum, stir, and use this solution as the control solution. Determine the remained potency of the sample solution and control solution after allowing to stand at $37 \pm 1^\circ\text{C}$ for 1 hour, according to the Assay. When the antiviral activity of Interferon Alfa (NAMALWA) is neutralized by anti-interferon alfa antiserum, it meets the requirement. Not detection of the remaining potency of the sample solution is a criterion of neutralization.

(2) Soak polyvinylidene fluoride membrane in methanol for 10 – 20 seconds, then soak additionally in phosphate-buffered sodium chloride TS for more than 30 minutes. To the well in the dot blot apparatus mounted the polyvinyl-

dene fluoride membrane, add a volume of Interferon Alfa (NAMALWA), corresponding to about 20 μg protein, allow to stand for 15 minutes, and aspirate. After repeating twice to aspirate with a 0.2-mL portion of phosphate-buffered sodium chloride TS, take out the polyvinylidene fluoride membrane, soak in 0.01 mol/L tris buffer solution-sodium chloride TS (pH 7.4), and stir gently for 10 minutes. Replace the liquid, and repeat this operation two more times. Remove 0.01 mol/L tris buffer solution-sodium chloride TS (pH 7.4), add elderberry lectin TS, and stir gently for 2 hours. Remove the elderberry lectin TS, add 0.01 mol/L tris buffer solution-sodium chloride TS (pH 7.4), and stir gently for 10 minutes. Replace the liquid, and repeat this operation two more times. Remove 0.01 mol/L tris buffer solution-sodium chloride TS (pH 7.4), add the peroxidase-labeled avidin TS, and stir gently for 15 minutes. Remove the peroxidase-labeled avidin TS, add 0.01 mol/L tris buffer solution-sodium chloride TS (pH 7.4), and stir gently for 10 minutes. Replace the liquid, and repeat this operation two more times. Remove 0.01 mol/L tris buffer solution-sodium chloride TS (pH 7.4), add substrate TS for interferon alfa identification, and allow to develop the color: a brown dot is observed.

Constituent amino acids When perform the test by Method 2 of 2. Methodologies of Amino Acid Analysis after hydrolyzing by Method 1 (but not containing phenol) of 1. Hydrolysis of Protein and Peptide under Amino Acid Analysis of Proteins <2.04>, the molar ratios of each constituent amino acid are 8–11 for aspartic acid, 4–7 for threonine, 7–10 for serine, 16–19 for glutamic acid, 2–4 for glycine and tyrosine, 5–7 for alanine, phenylalanine and lysine, 3–6 for valine, 2–5 for methionine, 4–6 for isoleucine, 12–15 for leucine, 1–3 for histidine and 6–9 for arginine.

(i) Hydrolysis—To Interferon Alfa (NAMALWA) add tris-glycine buffer solution (pH 6.8) so that each mL contains 6,000,000 Units. Pass 3 mL of the solution through a column 4 mm in internal diameter, packed with 0.145 g of ethylsilanized silica gel for column chromatography and previously washed with 5 mL of a mixture of water, acetonitrile and diluted trifluoroacetic acid (1 in 50) (13:6:1). Then, after washing with not less than 10 mL of a mixture of water, acetonitrile and diluted trifluoroacetic acid (1 in 50) (13:6:1), elute interferon alfa with 0.5 mL of a mixture of acetonitrile and diluted trifluoroacetic acid (1 in 50) (19:1), and use the eluate as the sample stock solution. To 0.45 mL of the sample stock solution add 50 μL of the internal standard solution, and stir. Transfer 0.1 mL each of this solution into two glass vessels for hydrolysis, and evaporate to dryness under reduced pressure. Add 20 μL of a solution which is prepared by adding 10 μL of mercapto acetic acid to 1 mL of 6 mol/L hydrochloric acid TS for amino acid automatic analysis, and 0.18 mL of 6 mol/L hydrochloric acid TS for amino acid automatic analysis to the bottom of the glass vessels, replace the air in the vessels with nitrogen, close the vessels tightly under reduced pressure, and heat at $110 \pm 2^\circ\text{C}$ for 24 hours for one of the vessels and for 72 hours for another. After cooling, open the vessels, evaporate the hydrolyzate to dryness under reduced pressure, dissolve the residue in 20 μL of water, and evaporate to dryness under reduced pressure. Dissolve the residues with 0.1 mL each of diluted 6 mol/L hydrochloric acid TS for amino acid automatic analysis (31 in 10,000), and use these solutions as the sample solutions (1) and (2), respectively. Separately, weigh exactly a suitable amount each of L-lysine hydrochloride, L-histidine hydrochloride monohydrate, L-arginine, L-aspartic acid, L-threonine, L-serine, L-glutamic acid, glycine, L-alanine, L-valine, L-methionine, L-isoleucine, L-leucine, L-tyrosine, L-

phenylalanine and L-norleucine, dissolve in diluted 6 mol/L hydrochloric acid TS for amino acid automatic analysis (31 in 10,000) so that each mL contains a certain concentration of about 20 nmol for each amino acid, and use this solution as the standard solution.

(ii) Amino acid analysis—When perform the test with 15 μL each of the sample solutions (1) and (2) and 10 μL of the standard solution as directed under Liquid Chromatography <2.01> according to the following conditions, either chromatogram obtained from the sample solutions shows the peaks corresponding to the peaks obtained from the standard solution. The molar ratios of each constituent amino acids are calculated. When calculate the molar ratios of each constituent amino acid, for threonine and serine the molar value is corrected by extrapolation to 0 hour-heating based on the values obtained from the sample solutions (1) and (2), for isoleucine and valine use the value from the sample solution (2), and for the other amino acids use the value from the sample solution (1). The molar ratios of cystine, proline and tryptophan are excluded from calculation.

Internal standard solution—To exactly 32.81 mg of L-norleucine add diluted 6 mol/L hydrochloric acid TS for amino acid automatic analysis (31 in 10,000) to make exactly 100 mL. Pipet 4 mL of this solution, add diluted 6 mol/L hydrochloric acid TS for amino acid automatic analysis (31 in 10,000) to make exactly 100 mL.

Operating conditions—

Detector: A fluorophotometer (excitation wavelength: 340 nm, fluorescence wavelength: 450 nm).

Column: A stainless steel column 5 mm in inside diameter and 8 cm in length, packed with strongly acidic ion-exchange resin (Na type) for liquid chromatography composed with a sulfonated styrene-divinylbenzene copolymer (3 μm in particle diameter).

Column temperature: Inject the sample at $50 \pm 1^\circ\text{C}$, maintain the temperature for 11 minutes, change to $40 \pm 1^\circ\text{C}$ and maintain for 23 minutes, then change to $65 \pm 1^\circ\text{C}$ and maintain for 56 minutes, and change to $45 \pm 1^\circ\text{C}$.

Reaction vessel temperature: A constant temperature of about 51°C .

Mobile phase: Prepare the mobile phases A, B, C and D according to the following table.

	Mobile phase A	Mobile phase B	Mobile phase C	Mobile phase D
Citric acid monohydrate	15.93 g	8.40 g	6.10 g	—
Sodium citrate hydrate	6.97 g	10.00 g	26.67 g	—
Sodium chloride	6.36 g	2.34 g	54.35 g	—
Sodium hydroxide	—	—	2.0 g	8.0 g
Ethanol (99.5)	54 mL	—	—	—
Lauromacrogol solution (1 in 4)	4 mL	4 mL	4 mL	4 mL
Benzyl alcohol	—	2 mL	5 mL	—
Caprylic acid	0.1 mL	0.1 mL	0.1 mL	0.1 mL
Water	a suitable quantity	a suitable quantity	a suitable quantity	a suitable quantity
Total amount	1000 mL	1000 mL	1000 mL	1000 mL

Flowing of mobile phase: Control the gradient by mixing the mobile phases A, B, C and D as directed in the following table.

Time after injection of sample (min)	Mobile phase A (vol%)	Mobile phase B (vol%)	Mobile phase C (vol%)	Mobile phase D (vol%)
0 - 11	100	0	0	0
11 - 12	100 → 0	0 → 100	0	0
12 - 34	0	100	0	0
34 - 39.1	0	100 → 0	0 → 100	0
39.1 - 71	0	0	100	0
71 - 86	0	0	0	100

Reaction reagent: Prepare the reaction reagents A, B and C according to the following table.

	Reaction reagent A	Reaction reagent B	Reaction reagent C
Sodium hydroxide	24.0 g	—	—
Boric acid	—	21.60 g	21.60 g
<i>o</i> -Phthalaldehyde in ethanol (99.5) solution (2 in 25)	—	—	10 mL
Lauromacrogol solution (1 in 4)	—	—	4 mL
2-Mercaptoethanol	—	—	2 mL
10% Sodium hypochlorite TS	—	0.1 mL	—
Water	a suitable quantity	a suitable quantity	a suitable quantity
Total amount	1000 mL	1000 mL	1000 mL

Flow rate of mobile phase: Adjust so that the retention times of aspartic acid, glutamic acid and methionine are about 12, 20 and 42 minutes, respectively.

Flow rate of reaction reagent: About 0.2 mL per minute for each of reagent A, B, and C.

System suitability—

System performance: When the procedure is run with 10 μ L of the standard solution under the above operating conditions, the resolutions between the peaks of threonine and serine, glycine and alanine, and isoleucine and leucine are not less than 0.6, not less than 0.8 and not less than 1.2, respectively.

System repeatability: When the test is repeated 3 times with 10 μ L of the standard solution under the above operating conditions, the relative standard deviations of the peak area of aspartic acid, proline, valine, and arginine are not more than 2.5%, respectively.

Molecular mass To a suitable amount of Interferon Alfa (NAMALWA) add tris-glycine buffer solution (pH 6.8) so that each mL contains 6,000,000 Units. To 3 volumes of this solution add 1 volume of reduction liquid for molecular mass determination, heat on a water bath for 90 seconds, and use this solution as the sample solution. Separately, to 3 volumes of molecular mass marker for interferon alfa add 1 volume of reduction liquid for molecular mass determination, heat on a water bath for 90 seconds, and use this solution as the standard solution. After performing the electrophoresis with 40 μ L of the sample solution and 15 μ L of the standard solution using tris buffer solution (pH 8.3) and polyacrylamide gel for interferon alfa, fix the gel by immersing for 1 hour in a solution of trichloroacetic acid (3 in 20). Then, stain the gel by immersing for more than 2 hours in a solution, prepared by dissolving 1.0 g of Coomassie brilliant blue R-250 in 450 mL of methanol and 100 mL of acetic acid (100) and adding water to make 1000 mL, and destain by immersing the gel in 1000 mL of a mixture of water, methanol and acetic acid (100) (33:4:3). Determine the relative mobility of each band obtained from the standard solution, and prepare a calibration curve by linear regression against the

logarithm of molecular mass. Determine the relative mobility of the center of the main band obtained from the sample solution, and calculate the molecular mass of Interferon Alfa (NAMALWA) from the calibration curve: at least 4 bands are observed between 17,000 and 30,000 of molecular mass.

Purity (1) Egg albumin, Sendai virus coat protein, other foreign proteins, and other process-related impurities—Being specified separately when the drug is granted approval based on the Law.

(2) Nucleic acids—Perform the test according to the following method: the amount of nucleic acids is not more than 1.0 μ g as DNA per 1,000,000 Units of interferon alfa (NAMALWA).

(i) DNA standard solutions: To the DNA standard stock solution for interferon alfa (NAMALWA) add salmon sperm DNA solution (1 in 10,000,000) so that each mL contains exactly 20 ng DNA. Hereinafter, the concentration of DNA is the concentration of DNA for interferon alfa (NAMALWA). To this solution add tris-glycine buffer solution (pH 6.8) exactly so that each mL contains 10 ng DNA. Then, dilute serially by adding tris-glycine buffer solution (pH 6.8). Dilute exactly with a mixture of tris-glycine buffer solution (pH 6.8) and 1 mol/L tris buffer solution (pH 8.0) (40:1) so that each mL contains 128, 64, 32, 16, 8, and 4 μ g of DNA, respectively, and use these solutions as DNA standard solutions.

(ii) Procedure: Use Interferon Alfa (NAMALWA) as the sample solution. Place 0.11 mL each of DNA standard solutions, a mixture of tris-glycine buffer solution (pH 6.8) and 1 mol/L tris buffer solution (pH 8.0) (43:1), and the sample solution into tubes separately. Heat these solutions in an aluminum block thermostat bath at 98°C for 10 minutes. After ice-cooling, centrifuge, and transfer 50 μ L each of the supernatants to new tubes. In separate wells of a PCR microplate place 6 μ L each of DNA standard solutions which have been treated by heating for DNA extraction, a mixture of tris-glycine buffer solution (pH 6.8) and 1 mol/L tris buffer solution (pH 8.0) (43:1), and the sample solution. Then, add 20 μ L each of a mixture of 2-fold PCR reaction solution containing SYBR Green, nuclease free water, primer F TS and primer R TS (167:70:10:10) into each well. Seal with plate film, and centrifuge. After centrifugation, attach the plate to a real-time PCR system, repeat 40 cycles of 15 seconds at 95°C and 1 minute at 60°C, and measure the fluorescence intensity of each well in every PCR cycle. Plot the fluorescent amount on the vertical axis and the PCR cycle number on the horizontal axis, and determine the PCR cycle number at which the fluorescence of each well is greater than a certain value. Further, make a calibration curve by plotting the number of PCR cycles on the vertical axis and the logarithm of the concentration of DNA standard solution on the horizontal axis to calculate the concentration of DNA in the sample solution.

System suitability—

Test for required detectability: The PCR cycle number obtained with 4 μ g/mL DNA standard solution is not greater than that obtained with a mixture of tris-glycine buffer solution (pH 6.8) and tris buffer solution (pH 8.0) (43:1).

System performance: When the procedure is run with each DNA standard solution under the above conditions, the correlation coefficient of the calibration curve obtained is 0.990 or more.

(3) Infective virus test—Inject 0.2 mL each of Interferon Alfa (NAMALWA) into the allantoic cavity of not less than 6 embryonated eggs, allow them to stand at $36 \pm 1^\circ\text{C}$ for 3

days, and then allow to stand at 4°C for a night. Collect more than 1 mL of the allantoic fluid from each egg. To 50 µL of the allantoic fluid add 50 µL of 0.5 vol% chicken erythrocyte suspension, mix, and allow to stand at room temperature for 1 hour. Examine the presence of the aggregation. When the aggregation is not found, inject 0.2 mL each of this allantoic fluid into the allantoic cavity of the embryonated eggs, and repeat the same procedure as above: the test is met when the aggregation is not found. As a positive control, inoculate the Sendai virus 1.6×10^{-4} to 6.4×10^{-4} HA value per embryonated chicken egg into the allantoic cavity, and perform the test at the same time.

Assay (1) Protein content—

(i) Sample solution: Dilute Interferon Alfa (NAMALWA) with isotonic sodium chloride solution so that each mL contains 3,000,000 to 4,000,000 Units, and use this solution as the sample solution.

(ii) Standard solution: Weigh accurately about 50 mg of bovine serum albumin, and dissolve in isotonic sodium chloride solution to make exactly 50 mL. Determine the absorbance of this solution at 280 nm as directed under Ultraviolet-visible Spectrophotometry <2.24>. Calculate the protein concentration based on $E_{1\text{cm}}^{1\%}(280\text{ nm}) = 6.6$. To this solution add isotonic sodium chloride solution so that each mL contains exactly 50, 25, 12.5, 6.25, and 3.13 µg of the bovine serum albumin, and use these solutions as the standard solutions.

(iii) Procedure: To exactly 0.25 mL each of the sample solution and the standard solutions add exactly 0.25 mL of Coomassie brilliant blue TS for interferon alfa, and allow to stand at room temperature for exactly 30 seconds. Determine the absorbance of these solutions at 614 nm as directed under Ultraviolet-visible Spectrophotometry <2.24> using water as the blank. Plot the absorbance of the standard solutions on the vertical axis and their protein concentrations on the horizontal axis to prepare a calibration curve. Determine the protein content of the sample solution from its absorbance using the calibration curve, and calculate the amount of protein per mL of the sample solution. Perform a blank determination in the same manner with isotonic sodium chloride solution, and make any necessary correction.

(2) Specific activity—To each well of a flat-bottom microplate add 45,000 to 60,000 cells of FL cell, prepared with Eagle's minimum essential medium containing bovine serum, and incubate at $37 \pm 1^\circ\text{C}$ for 18 to 22 hours in an incubator filled with 5% carbon dioxide. Dilute Interferon Alfa (NAMALWA) and Interferon Alfa RS separately with Eagle's minimum essential medium containing bovine serum so that each mL contains about 30 Units, and use these solutions as the sample solution (1) and the standard solution (1), respectively. To 200 µL each of these solutions add 117 µL of Eagle's minimum essential medium containing bovine serum, and use these solutions as the sample solution (2) and the standard solution (2), respectively. Repeat this operation, and prepare the sample solutions and standard solutions with log dilutions of 8 serials (dilution ratio per stage is $0.2 \log_{10}$ fold). Repeat to prepare the sample solutions three or more times. Add each sample solution or standard solution into each well of the cell culture, and incubate at $37 \pm 1^\circ\text{C}$ for 6 hours. Discard the culture medium, add 1×10^5 to 1×10^6 PFU of Sindbis virus per well, and incubate at $37 \pm 1^\circ\text{C}$ for 38 to 42 hours. Discard the culture medium, add neutral red-Eagle's minimum essential medium containing bovine serum, and incubate at $37 \pm 1^\circ\text{C}$ for 45 to 75 minutes. Discard the culture medium, and add 0.01 mol/L phosphate buffer solution. Discard the liquid. Repeat this

operation. Elute the neutral red that is taken up by the cells by adding sodium dihydrogen phosphate-ethanol TS. Determine the absorbance at 540 nm, prepare the dose-response curves by plotting the absorbances on the vertical axis and the logarithm of the dilution ratio on the horizontal axis with the absorbances obtained from the sample solution and standard solution. On the dose-response curves of the sample solution and standard solution, calculate the relative potency of the sample solution ($n = 3$ or more), obtained independently, to the standard solution by comparing the points where the intermediate of absorbances in cells infected with virus and cells not infected with virus, and calculate the average value of them as the potency of Interferon Alfa (NAMALWA) in 1 mL. Calculate the specific activity by dividing the obtained potency by the amount of protein content.

When all of the following conditions are satisfied, the test is valid.

Absorbance obtained from cells not infected with virus is 0.8 to 1.2.

Absorbance obtained from the cells infected with virus is not more than 0.1.

Standard deviation of the (log) potency of Interferon Alfa (NAMALWA) in 1 mL obtained from the sample solution prepared three or more times independently is not more than 0.06.

Containers and storage Containers—Tight containers.

Storage—Light-resistant, and at a temperature not exceeding 5°C, avoiding freezing.

Interferon Alfa (NAMALWA) Injection

インターフェロン アルファ(NAMALWA)注射液

Interferon Alfa (NAMALWA) Injection is an aqueous injection.

It contains not less than 70% and not more than 150% of the labelled amount of interferon alfa (NAMALWA).

Method of preparation Prepare as directed under Injections, with Interferon Alfa (NAMALWA).

Description Interferon Alfa (NAMALWA) Injection is a clear and colorless liquid.

Identification To Interferon Alfa (NAMALWA) Injection add Eagle's minimum essential medium containing bovine serum so that each mL contains 5000 Units, and use this solution as the sample stock solution. To anti-interferon alfa antiserum add an amount of Eagle's minimum essential medium containing bovine serum so that each mL contains an amount of anti-interferon alfa antiserum which neutralizes 10,000 Units of interferon alfa. To this solution add an equal volume of the sample stock solution, stir, and use this solution as the sample solution. Separately, to the sample stock solution add an equal volume of Eagle's minimum essential medium containing bovine serum, stir, and use this solution as the control solution. Determine the remained potency of the sample solution and control solution after allowing to stand at $37 \pm 1^\circ\text{C}$ for 1 hour, according to the Assay. When neutralized the antiviral activity of Interferon Alfa (NAMALWA) by anti-interferon alfa antiserum, it meets the requirement. Not detection of the remaining potency of the sample solution is the criterion of neutralization.

Osmotic pressure ratio Being specified separately when the drug is granted approval based on the Law.

pH Being specified separately when the drug is granted approval based on the Law.

Purity Multimers—To a suitable amount of Interferon Alfa (NAMALWA) Injection add tris-glycine buffer solution (pH 6.8) so that each mL contains 3,000,000 Units, and use this as the sample solution. Perform the test with 200 μ L of the sample solution as directed under Liquid Chromatography <2.01> according to the following conditions. Determine each peak area by the automatic integration method, and calculate their amounts by the area percentage method: the total amount of the peaks, having the retention time smaller than that of interferon alfa monomer, is not more than 3.0%.

Operating conditions—

Detector: An ultraviolet absorption photometer (wavelength: 220 nm).

Column: A glass column 10 mm in inside diameter and 30 cm in length, packed with dextran-highly cross-linked agarose gel filtration carrier for liquid chromatography.

Column temperature: A constant temperature of about 25°C.

Mobile phase: Dissolve 1.15 g of anhydrous disodium hydrogen phosphate, 0.2 g of potassium dihydrogen phosphate, 8.0 g of sodium chloride and 0.2 g of potassium chloride in water to make 1000 mL. To 950 mL of this solution add 50 mL of a solution prepared by dissolving 10 g of sodium lauryl sulfate in 100 mL of water, and mix gently.

Flow rate: 1 mL per minute.

Time span of measurement: Until the elution of interferon alfa monomer is completed.

System suitability—

Test for required detectability: Pipet 50 μ L of the sample solution, add tris-glycine buffer solution (pH 6.8) to make exactly 2 mL. Confirm that the peak area of the main peak obtained with 200 μ L of this solution is equivalent to 2.0 to 3.0% of that with 200 μ L of the sample solution.

System performance: Dissolve 15 mg of egg albumin for gel filtration molecular mass marker and 15 mg of ribonuclease A for gel filtration molecular mass marker in 100 mL of tris-glycine buffer solution (pH 6.8). When the procedure is run with 20 μ L of this solution under the above conditions, egg albumin and ribonuclease A are eluted in this order with the resolution between these peaks being not less than 2.0.

System repeatability: When the test is repeated 6 times with 200 μ L of the sample solution under the above operating conditions, the relative standard deviation of the area of the main peak is not more than 2.0%.

Bacterial endotoxins <4.01> Less than 0.25 EU per 600,000 Units.

Extractable volume <6.05> It meets the requirement.

Foreign insoluble matter <6.06> Perform the test according to Method1: it meets the requirement.

Insoluble particulate matter <6.07> It meets the requirement.

Sterility <4.06> Perform the test according to the Membrane filtration method: it meets the requirement.

Assay To each well of a flat-bottom microplate add 45,000 to 60,000 cells of FL cell, prepared with Eagle's minimum essential medium containing bovine serum, and incubate at 37 \pm 1°C for 18 to 22 hours in an incubator filled with 5%

carbon dioxide. Dilute Interferon Alfa (NAMALWA) Injection and Interferon Alfa RS separately with Eagle's minimum essential medium containing bovine serum so that each mL contains about 30 Units, and use these solutions as the sample solution (1) and the standard solution (1), respectively. To 200 μ L each of these solutions add 117 μ L of Eagle's minimum essential medium containing bovine serum, and use these solutions as the sample solution (2) and the standard solution (2), respectively. Repeat this operation, and prepare the sample solutions and standard solutions with logarithm dilutions of 8 serials (dilution ratio per stage is 0.2 log₁₀ fold). Repeat to prepare the sample solutions three or more times. Add each sample solution or each standard solution into each well of the cell culture, and incubate at 37 \pm 1°C for 6 hours. Discard the culture medium, add 1 \times 10⁵ to 1 \times 10⁶ PFU of Sindbis virus per well, and incubate at 37 \pm 1°C for 38 to 42 hours. Discard the culture medium, add neutral red-Eagle's minimum essential medium containing bovine serum, and incubate at 37 \pm 1°C for 45 to 75 minutes. Discard the culture medium, and add 0.01 mol/L phosphate buffer solution. Discard the liquid. Repeat this operation. Elute the neutral red that is taken up by the cells by adding sodium dihydrogen phosphate-ethanol TS. Determine the absorbance at 540 nm, prepare the dose-response curves by plotting the absorbances on the vertical axis and the logarithm of the dilution ratio on the horizontal axis with the absorbances obtained from the sample solution and standard solution. On the dose-response curves of the sample solution and standard solution, calculate the relative potency of the sample solution (n = 3 or more), prepared independently, to the standard solution by comparing the points where the intermediate of absorbances in cells infected with virus and cells not infected with virus, and calculate the average value of them as the potency of Interferon Alfa (NAMALWA) in 1 mL.

When all of the following conditions are satisfied, the test is valid.

Absorbance obtained from cells not infected with virus is 0.8 to 1.2.

Absorbance obtained from the cells infected with virus is not more than 0.1.

Standard deviation of the (log) potency of Interferon Alfa (NAMALWA) Injection in 1 mL obtained from the sample solution prepared three or more times independently is not more than 0.06.

Containers and storage Containers—Hermetic containers.

Storage—Light-resistant, and at a temperature not exceeding 10°C, avoiding freezing.

Iodinated (¹³¹I) Human Serum Albumin Injection

ヨウ化人血清アルブミン (¹³¹I) 注射液

Iodinated (¹³¹I) Human Serum Albumin Injection is an aqueous injection containing normal human serum albumin iodinated by iodine-131 (¹³¹I).

It conforms to the requirements of Iodinated (¹³¹I) Human Serum Albumin Injection in the Minimum Requirements for Radiopharmaceuticals.

Test for Extractable Volume of Parenteral Preparations and Insoluble Particulate Matter Test for Injections are not applied to this injection.

Description Iodinated (¹³¹I) Human Serum Albumin Injec-

tion is a clear, colorless or light yellow liquid.

Iodine

ヨウ素

I: 126.90

Iodine contains not less than 99.5% of iodine (I).

Description Iodine occurs as grayish black, plates or granular, heavy crystals, having a metallic luster and a characteristic odor.

It is freely soluble in diethyl ether, soluble in ethanol (95), sparingly soluble in chloroform, and very slightly soluble in water.

It dissolves in potassium iodide TS.

It sublimes at room temperature.

Identification (1) A solution of Iodine in ethanol (95) (1 in 50) shows a red-brown color.

(2) A solution of Iodine in chloroform (1 in 1000) shows a red-purple to purple color.

(3) Add 0.5 mL of starch TS to 10 mL of a saturated solution of Iodine: a dark blue color is produced. When the mixture is boiled, the color disappears, and it reappears on cooling.

Purity (1) Non-volatile residue—Sublime 2.0 g of Iodine on a water bath, and dry the residue at 105°C for 1 hour: the mass of the residue is not more than 1.0 mg.

(2) Chloride or bromide—Mix 1.0 g of finely powdered Iodine with 20 mL of water, and filter the mixture. To 10 mL of the filtrate add dropwise diluted sulfurous acid solution (1 in 5) until the yellow color disappears. Add 1 mL of ammonia TS, followed by 1 mL of silver nitrate TS in small portions, and add water to make 20 mL. Shake well, filter, and after discarding the first 2 mL of the filtrate, take 10 mL of the subsequent filtrate. To the filtrate add 2.0 mL of nitric acid and water to make 20 mL: the solution so obtained has no more turbidity than the following control solution.

Control solution: To 0.20 mL of 0.01 mol/L hydrochloric acid VS add 5 mL of water, 2.5 mL of ammonia TS, 1 mL of silver nitrate TS, 2.0 mL of nitric acid and water to make 20 mL.

Assay Place 1 g of potassium iodide and 1 mL of water in a glass-stoppered flask, weigh accurately, add about 0.3 g of Iodine to the flask, and weigh accurately again. Dissolve the iodine by gentle shaking, add 20 mL of water and 1 mL of dilute hydrochloric acid, and titrate <2.50> with 0.1 mol/L sodium thiosulfate VS (indicator: 1 mL of starch TS).

Each mL of 0.1 mol/L sodium thiosulfate VS
= 12.69 mg of I

Containers and storage Containers—Tight containers.

Iodine Tincture

ヨードチンキ

Iodine Tincture contains not less than 5.7 w/v% and not more than 6.3 w/v% of iodine (I: 126.90), and not less than 3.8 w/v% and not more than 4.2 w/v% of potassium iodide (KI: 166.00).

Method of preparation

Iodine	60 g
Potassium Iodide	40 g
70 vol% Ethanol	a sufficient quantity
To make 1000 mL	

Prepare as directed under Spirits, with the above ingredients. It may be prepared with an appropriate quantity of Ethanol or Ethanol for Disinfection and Purified Water or Purified Water in Containers in place of 70 vol% Ethanol.

Description Iodine Tincture is a dark red-brown liquid, and has a characteristic odor.

Specific gravity d_{20}^{20} : about 0.97

Identification (1) To a mixture of 1 mL of starch TS and 9 mL of water add 1 drop of Iodine Tincture: a dark blue-purple color develops.

(2) Evaporate 3 mL of Iodine Tincture to dryness on a water bath, and heat gently over a free flame: a white residue is formed which responds to Qualitative Tests <1.09> for potassium salt and iodide.

Alcohol number <1.01> Not less than 6.6 (Method 2). Perform the pretreatment (ii) in the Method 1.

Assay (1) Iodine—Pipet 5 mL of Iodine Tincture, add 0.5 g of potassium iodide, 20 mL of water and 1 mL of dilute hydrochloric acid, and titrate <2.50> with 0.1 mol/L sodium thiosulfate VS (indicator: 2 mL of starch TS).

Each mL of 0.1 mol/L sodium thiosulfate VS
= 12.69 mg of I

(2) Potassium iodide—Pipet 5 mL of Iodine Tincture into an iodine flask, add 20 mL of water, 50 mL of hydrochloric acid and 5 mL of chloroform. Cool to room temperature, and titrate <2.50> with 0.05 mol/L potassium iodate VS until the red-purple color disappears from the chloroform layer, with agitating the mixture vigorously and continuously. After the chloroform layer has been decolorized, allow the mixture to stand for 5 minutes. If the color reappears, the mixture should be titrated <2.50> further with 0.05 mol/L potassium iodate VS. Calculate the amount (mg) of potassium iodide from the number of mL (a) of 0.05 mol/L potassium iodate VS used as above and the number of mL (b) of 0.1 mol/L sodium thiosulfate VS used in the titration under the Assay (1).

Amount (mg) of potassium iodide (KI)
= $16.60 \times \{a - (b/2)\}$

Containers and storage Containers—Tight containers.

Dilute Iodine Tincture

希ヨードチンキ

Dilute Iodine Tincture contains not less than 2.8 w/v% and not more than 3.2 w/v% of iodine (I: 126.90), and not less than 1.9 w/v% and not more than 2.1 w/v% of potassium iodide (KI: 166.00).

Method of preparation

Iodine	30 g
Potassium Iodide	20 g
70 vol% Ethanol	a sufficient quantity
To make 1000 mL	

Prepare as directed under Spirits, with the above ingredients. It may be prepared with an appropriate quantity of Ethanol or Ethanol for Disinfection and Purified Water or Purified Water in Containers in place of 70 vol% Ethanol. It may also be prepared by adding 70 vol% Ethanol to 500 mL of Iodine Tincture to make 1000 mL.

Description Dilute Iodine Tincture is a dark red-brown liquid, and has a characteristic odor.

Specific gravity d_{20}^{20} : about 0.93

Identification (1) To a mixture of 1 mL of starch TS and 9 mL of water add 1 drop of Dilute Iodine Tincture: a dark blue-purple color develops.

(2) Evaporate 3 mL of Diluted Iodine Tincture to dryness on a water bath, and heat gently over a free flame: a white residue is formed which responds to the Qualitative Tests <1.09> for potassium salt and iodide.

Alcohol number <1.01> Not less than 6.7 (Method 2). Perform the pretreatment (ii) in the Method 1.

Assay (1) Iodine—Pipet exactly 10 mL of Dilute Iodine Tincture, add 0.5 g of potassium iodide, 20 mL of water and 1 mL of dilute hydrochloric acid, and titrate <2.50> with 0.1 mol/L sodium thiosulfate VS (indicator: 2 mL of starch TS).

$$\text{Each mL of 0.1 mol/L sodium thiosulfate VS} \\ = 12.69 \text{ mg of I}$$

(2) Potassium iodide—Pipet 10 mL of Dilute Iodine Tincture into an iodine flask, add 20 mL of water, 50 mL of hydrochloric acid and 5 mL of chloroform. Cool to room temperature, and titrate <2.50> with 0.05 mol/L potassium iodate VS until the red-purple color in the chloroform layer disappears while agitating vigorously and continuously. After the chloroform layer has been decolorized, allow the mixture to stand for 5 minutes. If the color reappears, the mixture should be titrated <2.50> further with 0.05 mol/L potassium iodate VS. Calculate the amount (mg) of potassium iodide from the volume (a mL) of 0.05 mol/L potassium iodate VS consumed as above and the volume (b mL) of 0.1 mol/L sodium thiosulfate VS consumed in the titration under Assay (1).

$$\text{Amount (mg) of potassium iodide (KI)} \\ = 16.60 \times \{a - (b/2)\}$$

Containers and storage Containers—Tight containers.

Compound Iodine Glycerin

複方ヨード・グリセリン

Compound Iodine Glycerin contains not less than 1.1 w/v% and not more than 1.3 w/v% of iodine (I: 126.90), not less than 2.2 w/v% and not more than 2.6 w/v% of potassium iodide (KI: 166.00), not less than 2.7 w/v% and not more than 3.3 w/v% of total iodine (as I), and not less than 0.43 w/v% and not more than 0.53 w/v% of phenol (C₆H₆O: 94.11).

Method of preparation

Iodine	12 g
Potassium Iodide	24 g
Glycerin	900 mL
Mentha Water	45 mL
Liquefied Phenol	5 mL
Purified Water or Purified Water in Containers	a sufficient quantity
To make 1000 mL	

Dissolve Potassium Iodide and Iodine in about 25 mL of Purified Water or Purified Water in Containers. After adding Glycerin, add Mentha Water, Liquefied Phenol and sufficient Purified Water or Purified Water in Containers to make 1000 mL, mixing thoroughly. It may be prepared with an appropriate quantity of Concentrated Glycerin and Purified Water or Purified Water in Containers in place of Glycerin, and with an appropriate quantity of Phenol and Purified Water or Purified Water in Containers in place of Liquefied Phenol.

Description Compound Iodine Glycerin is a red-brown, viscous liquid. It has a characteristic odor.

Specific gravity d_{20}^{20} : about 1.23

Identification (1) The colored solution obtained in the Assay (1) acquires a red color. Determine the absorption spectrum of this solution as directed under Ultraviolet-visible Spectrophotometry <2.24>: it exhibits a maximum between 510 nm and 514 nm (iodine).

(2) The colored solution obtained in the Assay (2) acquires a red color. Determine the absorption spectrum of this solution as directed under Ultraviolet-visible Spectrophotometry <2.24>: it exhibits a maximum between 510 nm and 514 nm (potassium iodide).

(3) The colored solution obtained in the Assay (4) has a yellow color. Determine the absorption spectrum of this solution as directed under Ultraviolet-visible Spectrophotometry <2.24>: it exhibits a maximum between 401 nm and 405 nm (phenol).

(4) Take 1 mL of Compound Iodine Glycerin in a glass-stoppered test tube, add 10 mL of ethanol (95), and mix. Then add 2 mL of sodium hydroxide TS, add 1 mL of a solution of copper (II) chloride dihydrate in ethanol (95) (1 in 10), and shake: a blue color develops (glycerin).

Assay (1) Iodine—Measure the specific gravity of Compound Iodine Glycerin according to Method 2 under Determination of Specific gravity and density <2.56>. Weigh exactly about 7 mL of it, add ethanol (95) to make exactly 200 mL, and use this solution as the sample solution. On the other hand, weigh accurately about 80 mg of iodine for assay and about 0.17 g of potassium iodide for assay, previously dried at 105°C for 4 hours, dissolve in ethanol (95) to make exactly 200 mL, and use this solution as the standard solu-

tion. Pipet 3 mL each of the sample solution and the standard solution into 50-mL separators, to each add exactly 10 mL of a mixture of chloroform and hexane (2:1) and 15 mL of water successively, and shake immediately and vigorously. Separate the chloroform-hexane layers [use the water layers in (2)], and filter through a pledget of cotton. Determine the absorbances of the filtrates, A_T and A_S , at 512 nm as directed under Ultraviolet-visible Spectrophotometry <2.24>, using a mixture of chloroform and hexane (2:1) as the blank.

$$\text{Amount (mg) of iodine (I)} = M_S \times A_T/A_S$$

M_S : Amount (mg) of iodine for assay taken

(2) Potassium iodide—Separate the water layers of the sample solution and the standard solution obtained in (1), pipet 10 mL of each of the water layers, and to each add 1 mL of diluted dilute hydrochloric acid (1 in 2), 1 mL of sodium nitrite TS and exactly 10 mL of a mixture of chloroform and hexane (2:1). Shake immediately and vigorously, separate the chloroform-hexane layers, and filter through a pledget of cotton. Determine the absorbances, A_T and A_S , of both solutions at 512 nm as directed under Ultraviolet-visible Spectrophotometry <2.24>, using a mixture of chloroform and hexane (2:1) as the blank.

$$\text{Amount (mg) of potassium iodide (KI)} = M_S \times A_T/A_S$$

M_S : Amount (mg) of potassium iodide for assay taken

(3) Total iodine—Measure the specific gravity of Compound Iodine Glycerin according to Method 2 under Determination of Specific gravity and density <2.56>. Weigh exactly about 5 mL of it, and add water to make exactly 50 mL. Pipet 5 mL of this solution into a 50-mL flask, and add 0.5 g of zinc powder and 5 mL of acetic acid (100). Shake until the color of iodine disappears, and heat under a reflux condenser on a water bath for 30 minutes. Wash the condenser with 10 mL of hot water, and filter through a glass filter (G3). Wash the flask with two 10-mL portions of warm water, and combine the filtrate and the washings. After cooling, add water to make exactly 50 mL, and use this solution as the sample solution. On the other hand, dissolve about 0.2 g of potassium iodide for assay, previously dried at 105°C for 4 hours and accurately weighed, in water to make exactly 50 mL. Pipet 5 mL of this solution, add 5 mL of acetic acid (100) and water to make exactly 50 mL, and use this solution as the standard solution. Pipet 4 mL each of the sample solution and standard solution into 30-mL separators, and to each add 5 mL of water, 1 mL of diluted dilute hydrochloric acid (1 in 2), 1 mL of sodium nitrite TS and 10 mL of a mixture of chloroform and hexane (2:1). Shake well immediately, and proceed as directed in (2).

$$\text{Amount (mg) of total iodine (I)} = M_S \times A_T/A_S \times 0.764$$

M_S : Amount (mg) of potassium iodide for assay taken

(4) Phenol—Measure the specific gravity of Compound Iodine Glycerin according to Method 2 under Determination of Specific gravity and density <2.56>. Weigh exactly about 2 mL of it, add 3 mL of 0.1 mol/L sodium thiosulfate VS, and shake. Add 2 mL of dilute hydrochloric acid, and shake with two 10-mL portions of chloroform. Separate the chloroform layer, and shake with two 10-mL portions of 0.5 mol/L sodium hydroxide TS. Separate the water layer, add water to make exactly 500 mL, and use this solution as the sample solution. Dissolve about 0.5 g of phenol for assay, accurately weighed, in ethanol (95) to make exactly 100 mL, pipet 2 mL of this solution, proceed in the same manner as the sample

solution, and use so obtained solution as the standard solution. Pipet 3 mL each of the sample solution and standard solution, to each add 2 mL of dilute hydrochloric acid, and place in a water bath at 30°C. Allow to stand for 10 minutes, and add exactly 2 mL of a solution of sodium nitrite (1 in 100), shake, and allow to stand at 30°C for 60 minutes. Add dilute potassium hydroxide-ethanol TS to make exactly 25 mL, and determine the absorbances of these solutions, A_T and A_S , at 403 nm as directed under Ultraviolet-visible Spectrophotometry <2.24>, using the solution prepared in the same manner with 3 mL of water instead of the sample solution as the blank.

$$\begin{aligned} \text{Amount (mg) of phenol (C}_6\text{H}_6\text{O)} \\ = M_S \times A_T/A_S \times 1/50 \end{aligned}$$

M_S : Amount (mg) of phenol for assay taken

Containers and storage Containers—Tight containers.

Storage—Light-resistant.

Dental Iodine Glycerin

歯科用ヨード・グリセリン

Dental Iodine Glycerin contains not less than 9.0 w/v% and not more than 11.0 w/v% of iodine (I: 126.90), not less than 7.2 w/v% and not more than 8.8 w/v% of potassium iodide (KI: 166.00), and not less than 0.9 w/v% and not more than 1.1 w/v% of zinc sulfate hydrate (ZnSO₄·7H₂O: 287.55).

Method of preparation

Iodine	10 g
Potassium Iodide	8 g
Zinc Sulfate Hydrate	1 g
Glycerin	35 mL
Purified Water or Purified	
Water in Containers	a sufficient quantity
To make 100 mL	

Dissolve and mix the above ingredients.

Description Dental Iodine Glycerin is a dark red-brown liquid, having the odor of iodine.

Identification (1) The colored solution obtained in the Assay (1) acquires a red color. Determine the absorption spectrum of this solution as directed under Ultraviolet-visible Spectrophotometry <2.24>: it exhibits a maximum between 510 nm and 514 nm (iodine).

(2) The colored solution obtained in the Assay (2) acquires a red color. Determine the absorption spectrum of this solution as directed under Ultraviolet-visible Spectrophotometry <2.24>: it exhibits a maximum between 510 nm and 514 nm (potassium iodide).

(3) Put 1 mL of Dental Iodine Glycerin in a glass-stoppered, test tube, add 10 mL of ethanol (95), and mix. Then add 2 mL of sodium hydroxide TS, add 1 mL of a solution of copper (II) chloride dihydrate in ethanol (95) (1 in 10), and shake: a blue color develops (glycerin).

(4) The colored solution obtained in the Assay (3) acquires a red-purple to purple color. Determine the absorption spectrum of this solution as directed under Ultraviolet-visible Spectrophotometry <2.24>: it exhibits a maximum between 618 nm and 622 nm (zinc sulfate hydrate).

Assay (1) Iodine—Pipet 5 mL of Dental Iodine Glycerin,

and add diluted ethanol (3 in 10) to make exactly 50 mL. Pipet 5 mL of this solution, add water to make exactly 200 mL, and use this solution as the sample solution. On the other hand, weigh accurately about 0.5 g of iodine for assay and about 0.4 g of potassium iodide for assay, previously dried at 105°C for 4 hours, and dissolve in diluted ethanol (3 in 10) to make exactly 50 mL. Pipet 5 mL of this solution, add water to make exactly 200 mL, and use this solution as the standard solution. Pipet 10 mL each of the sample solution and standard solution, to each add exactly 20 mL of a mixture of chloroform and hexane (2:1), shake immediately, and separate the chloroform-hexane layer [use the water layer in (2)]. Filter through a pledget of cotton. Determine the absorbances, A_T and A_S , of the filtrates obtained from the sample solution and standard solution, respectively, at 512 nm as directed under Ultraviolet-visible Spectrophotometry <2.24>, using a mixture of chloroform and hexane (2:1) as the blank.

$$\text{Amount (mg) of iodine (I)} = M_S \times A_T/A_S$$

M_S : Amount (mg) of iodine for assay taken

(2) Potassium iodide—Separate the water layers of the sample solution and standard solution obtained in (1), pipet 7 mL each of the water layers, and to each add exactly 1 mL of diluted hydrochloric acid (1 in 2), 1 mL of sodium nitrite TS and 10 mL of a mixture of chloroform and hexane (2:1), and shake immediately. Separate the chloroform-hexane layer, and filter through a pledget of cotton. Determine the absorbances, A_T and A_S , of the filtrates obtained from the sample solution and standard solution, respectively, at 512 nm as directed under Ultraviolet-visible Spectrophotometry, using a mixture of chloroform and hexane (2:1) as the blank.

$$\text{Amount (mg) of potassium iodide (KI)} = M_S \times A_T/A_S$$

M_S : Amount (mg) of potassium iodide for assay taken

(3) Zinc sulfate hydrate—Pipet 5 mL of Dental Iodine Glycerin, and add diluted ethanol (3 in 10) to make exactly 50 mL. Pipet 5 mL of this solution, add water to make exactly 100 mL, and use this solution as the sample solution. On the other hand, pipet 10 mL of Standard Zinc Stock Solution, add diluted ethanol (3 in 200) to make exactly 1000 mL, and use this solution as the standard solution. Pipet 10 mL each of the sample solution and standard solution, to each add 10 mL of a mixture of chloroform and hexane (2:1), shake, and allow to stand. Pipet 3 mL each of the water layers, and to each add 2 mL of boric acid-potassium chloride-sodium hydroxide buffer solution (pH 10.0), 2 mL of zincon TS and water to make exactly 25 mL. Determine the absorbances, A_T and A_S , obtained from the sample solution and standard solution, respectively, at 620 nm as directed under Ultraviolet-visible Spectrophotometry <2.24>, using the solution prepared in the same manner with 3 mL of water as the blank.

$$\begin{aligned} \text{Amount (mg) of zinc sulfate hydrate (ZnSO}_4\cdot 7\text{H}_2\text{O)} \\ = M_S \times A_T/A_S \times 4.398 \end{aligned}$$

M_S : Amount (mg) of zinc in 10 mL of Standard Zinc Stock Solution

Containers and storage Containers—Tight containers.

Storage—Light-resistant.

Iodine, Salicylic Acid and Phenol Spirit

ヨード・サリチル酸・フェノール精

Iodine, Salicylic Acid and Phenol Spirit contains not less than 1.08 w/v% and not more than 1.32 w/v% of iodine (I: 126.90), not less than 0.72 w/v% and not more than 0.88 w/v% of potassium iodide (KI: 166.00), not less than 4.5 w/v% and not more than 5.5 w/v% of salicylic acid ($\text{C}_7\text{H}_6\text{O}_3$: 138.12), not less than 1.8 w/v% and not more than 2.2 w/v% of phenol ($\text{C}_6\text{H}_6\text{O}$: 94.11), and not less than 7.2 w/v% and not more than 8.8 w/v% of benzoic acid ($\text{C}_7\text{H}_6\text{O}_2$: 122.12).

Method of preparation

Iodine Tincture	200 mL
Salicylic Acid	50 g
Phenol	20 g
Benzoic Acid	80 g
Ethanol for Disinfection	a sufficient quantity

To make 1000 mL

Prepare as directed under Spirits, with the above ingredients. It may be prepared with an appropriate quantity of Ethanol and Purified Water or Purified Water in Containers in place of Ethanol for Disinfection.

Description Iodine, Salicylic Acid and Phenol Spirit is a dark red-brown liquid, having the odor of phenol.

Identification (1) To a mixture of 1 mL of starch TS and 9 mL of water add 1 drop of Iodine, Salicylic Acid and Phenol Spirit: a dark blue-purple color develops (iodine).

(2) To 1 mL of Iodine, Salicylic Acid and Phenol Spirit add 5 mL of ethanol (95) and water to make 50 mL. To 1 mL of this solution add hydrochloric acid-potassium chloride buffer solution (pH 2.0) to make 50 mL, and to 15 mL of this solution add 5 mL of a solution of iron (III) nitrate enneahydrate (1 in 200): a red-purple color is produced (salicylic acid).

(3) Shake 1 mL of Iodine, Salicylic Acid and Phenol Spirit with 1 mL of sodium thiosulfate TS, add 20 mL of water and 5 mL of dilute hydrochloric acid, and extract with 25 mL of diethyl ether. Wash the diethyl ether extract with two 25-mL portions of sodium hydrogen carbonate TS, and extract with 10 mL of dilute sodium hydroxide TS. Shake 1 mL of the extract with 1 mL of sodium nitrite TS and 1 mL of dilute hydrochloric acid, and add 3 mL of sodium hydroxide TS: a yellow color is developed (phenol).

(4) Shake 1 mL of Iodine, Salicylic Acid and Phenol Spirit with 1 mL of sodium thiosulfate TS, add 20 mL of water and 5 mL of dilute hydrochloric acid, extract with 10 mL of diethyl ether, and use the diethyl ether extract as the sample solution. Dissolve 25 mg of salicylic acid, 10 mg of phenol and 40 mg of benzoic acid in 5 mL each of diethyl ether, respectively, and use these solutions as the standard solutions (1), (2) and (3). Perform the test with these solutions as directed under Thin-layer Chromatography <2.03>. Spot 5 μL each of the sample solution and standard solutions (1), (2) and (3) on a plate of silica gel with fluorescent indicator for thin-layer chromatography. Develop the plate with a mixture of chloroform, acetone and acetic acid (100) (45:5:1) to a distance of about 10 cm, and air-dry the plate. Examine under ultraviolet light (main wavelength: 254 nm): the 3

spots from the sample solution show the same R_f value as the corresponding spots of the standard solutions (1), (2) and (3). Spray evenly iron (III) chloride TS on the plate: the spot from standard solution (1) and the corresponding spot from the sample solution acquires a purple color.

Assay (1) Iodine—Pipet 4 mL of Iodine, Salicylic Acid and Phenol Spirit, add ethanol (95) to make exactly 50 mL, and use this solution as the sample solution. On the other hand, weigh accurately about 1.2 g of iodine for assay and about 0.8 g of potassium iodide for assay, previously dried at 105°C for 4 hours, and dissolve in ethanol (95) to make exactly 100 mL. Pipet 4 mL of this solution, add ethanol (95) to make exactly 50 mL, and use this solution as the standard solution. Pipet 3 mL each of the sample solution and standard solution, to each add exactly 25 mL of a mixture of chloroform and hexane (2:1), and shake. Further add exactly 10 mL of water, shake and separate the chloroform-hexane layers [use the water layers in (2)]. Filter through a pledget of absorbent cotton, and determine the absorbances of the filtrates from the sample solution and standard solution, respectively, A_T and A_S , at 512 nm as directed under Ultraviolet-visible Spectrophotometry <2.24>, using a mixture of chloroform and hexane (2:1) as the blank.

$$\text{Amount (mg) of iodine (I)} = M_S \times A_T/A_S \times 1/25$$

M_S : Amount (mg) of iodine for assay taken

(2) Potassium iodide—Separate the water layers of the sample solution and standard solution obtained in the Assay (1), pipet 8 mL each of the water layers, and add 1 mL of diluted dilute hydrochloric acid (1 in 2) and 1 mL of sodium nitrite TS. Immediately after shaking, add exactly 10 mL of a mixture of chloroform and hexane (2:1), shake, and proceed in the same manner as for the Assay (1).

$$\begin{aligned} \text{Amount (mg) of potassium iodide (KI)} \\ = M_S \times A_T/A_S \times 1/25 \end{aligned}$$

M_S : Amount (mg) of potassium iodide for assay taken

(3) Salicylic acid, phenol and benzoic acid—Pipet 2 mL of Iodine, Salicylic Acid and Phenol Spirit, add 20 mL of diluted methanol (1 in 2) and 0.1 mol/L sodium thiosulfate VS until the color of iodine disappears, add exactly 20 mL of the internal standard solution, then add diluted methanol (1 in 2) to make 200 mL, and use this solution as the sample solution. Weigh accurately about 0.2 g of salicylic acid for assay, previously dried in a desiccator (silica gel) for 3 hours, about 80 mg of phenol for assay, and 0.32 g of benzoic acid, previously dried in a desiccator (silica gel) for 3 hours, dissolve in diluted methanol (1 in 2) to make exactly 50 mL. Pipet 25 mL of this solution, add exactly 20 mL of the internal standard solution and diluted methanol (1 in 2) to make 200 mL, and use this solution as the standard solution. Perform the test with 3 μ L of the sample solution and standard solution as directed under Liquid Chromatography <2.01> according to the following conditions. Calculate the ratios, Q_{Ta} , Q_{Tb} and Q_{Tc} , of the peak areas of salicylic acid, phenol and benzoic acid to those of the internal standard of the sample solution, and the ratios, Q_{Sa} , Q_{Sb} and Q_{Sc} , of the peak areas of salicylic acid, phenol and benzoic acid to those of the internal standard of the standard solution.

$$\begin{aligned} \text{Amount (mg) of salicylic acid (C}_7\text{H}_6\text{O}_3\text{)} \\ = M_{Sa} \times Q_{Ta}/Q_{Sa} \times 1/2 \end{aligned}$$

$$\begin{aligned} \text{Amount (mg) of phenol (C}_6\text{H}_6\text{O)} \\ = M_{Sb} \times Q_{Tb}/Q_{Sb} \times 1/2 \end{aligned}$$

$$\begin{aligned} \text{Amount (mg) of benzoic acid (C}_7\text{H}_6\text{O}_2\text{)} \\ = M_{Sc} \times Q_{Tc}/Q_{Sc} \times 1/2 \end{aligned}$$

M_{Sa} : Amount (mg) of salicylic acid for assay taken

M_{Sb} : Amount (mg) of phenol for assay taken

M_{Sc} : Amount (mg) of benzoic acid taken

Internal standard solution—A solution of theophylline in methanol (1 in 1000).

Operating conditions—

Detector: An ultraviolet absorption photometer (wavelength: 270 nm).

Column: A stainless steel column about 4 mm in inside diameter and 25 to 30 cm in length, packed with octadecylsilanized silica gel for liquid chromatography (5 μ m in particle diameter).

Column temperature: Room temperature.

Mobile phase: A mixture of 0.1 mol/L phosphate buffer solution (pH 7.0) and methanol (3:1).

Flow rate: Adjust so that the retention time of salicylic acid is about 6 minutes.

Selection of column: Dissolve 0.2 g of benzoic acid, 0.2 g of salicylic acid and 50 mg of theophylline in 100 mL of diluted ethanol (1 in 2). To 10 mL of this solution add 90 mL of diluted methanol (1 in 2). Proceed with 10 μ L of this solution under the above operating conditions. Use a column giving elution of benzoic acid, salicylic acid and theophylline in this order, and clearly dividing each peak.

Containers and storage Containers—Tight containers.

Storage—Light-resistant.

Iodoform

ヨードホルム



CHI₃: 393.73
Triiodomethane
[75-47-8]

Iodoform, when dried, contains not less than 99.0% of iodoform (CHI₃).

Description Iodoform occurs as lustrous, yellow crystals or crystalline powder. It has a characteristic odor.

It is freely soluble in diethyl ether, sparingly soluble in ethanol (95), and practically insoluble in water.

It is slightly volatile at ordinary temperature.

Melting point: about 120°C (with decomposition).

Identification Heat 0.1 g of Iodoform: a purple gas is evolved.

Purity (1) Water-soluble colored substances and acidity or alkalinity—Shake well 2.0 g of Iodoform, previously powdered, with 5 mL of water for 1 minute, allow to stand, and filter the supernatant liquid: the filtrate is colorless and neutral.

(2) Chloride <1.03>—Shake well 3.0 g of Iodoform, previously powdered, with 75 mL of water for 1 minute, allow to stand, and filter the supernatant liquid. To 25 mL of the filtrate add 6 mL of dilute nitric acid and water to make 50 mL, and perform the test using this solution as the test solution. Prepare the control solution with 0.30 mL of 0.01 mol/L hydrochloric acid VS (not more than 0.011%).

(3) Sulfate <1.14>—To 25 mL of the filtrate obtained in

(2) add 1 mL of dilute hydrochloric acid and water to make 50 mL, and perform the test using this solution as the test solution. Prepare the control solution with 0.35 mL of 0.005 mol/L sulfuric acid VS (not more than 0.017%).

Loss on drying <2.41> Not more than 0.5% (1 g, silica gel, 24 hours).

Residue on ignition <2.44> Not more than 0.1% (1 g).

Assay Weigh accurately about 0.2 g of Iodoform, previously dried, in a 500-mL glass-stoppered flask, and dissolve it in 20 mL of ethanol (95). Add exactly 30 mL of 0.1 mol/L silver nitrate VS and 10 mL of nitric acid, stopper the flask, shake well, and allow to stand in a dark place over 16 hours. Add 150 mL of water, and titrate <2.50> the excess silver nitrate with 0.1 mol/L ammonium thiocyanate VS (indicator: 5 mL of ammonium iron (III) sulfate TS). Perform a blank determination in the same manner.

Each mL of 0.1 mol/L silver nitrate VS
= 13.12 mg of CHI_3

Containers and storage Containers—Tight containers.

Storage—Light-resistant.

Iohexol

イオヘキソール

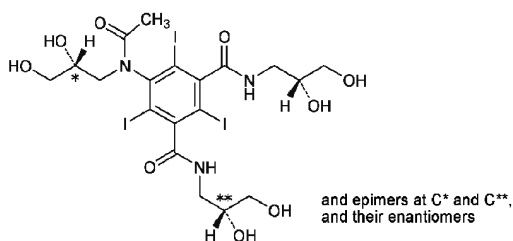

$\text{C}_{19}\text{H}_{26}\text{I}_3\text{N}_3\text{O}_9$; 821.14

5-[Acetyl[(2*RS*)-2,3-dihydroxypropyl]amino]-*N,N'*-bis[(2*RS*)-2,3-dihydroxypropyl]-2,4,6-triiodobenzene-1,3-dicarboxamide

5-[Acetyl[(2*RS*)-2,3-dihydroxypropyl]amino]-*N*-[(2*RS*)-2,3-dihydroxypropyl]-*N'*-[(2*SR*)-2,3-dihydroxypropyl]-2,4,6-triiodobenzene-1,3-dicarboxamide

5-[Acetyl[(2*RS*)-2,3-dihydroxypropyl]amino]-*N,N'*-bis[(2*SR*)-2,3-dihydroxypropyl]-2,4,6-triiodobenzene-1,3-dicarboxamide
[66108-95-0]

Iohexol is a mixture of endo- and exo-products of iohexol.

It contains not less than 98.5% and not more than 101.0% of iohexol ($\text{C}_{19}\text{H}_{26}\text{I}_3\text{N}_3\text{O}_9$), calculated on the anhydrous basis.

Description Iohexol occurs as a white powder.

It is very soluble in water, freely soluble in methanol and sparingly soluble in ethanol (99.5).

It dissolves in a solution of sodium hydroxide (1 in 20).

A solution of Iohexol (1 in 20) shows no optical rotation.

Identification (1) Determine the absorption spectrum of a solution of Iohexol (13 in 1,000,000) as directed under Ultraviolet-visible Spectrophotometry <2.24>, and compare the spectrum with the Reference Spectrum: both spectra exhibit similar intensities of absorption at the same wavelengths.

(2) Determine the infrared absorption spectrum of Iohexol, previously dried at 105°C for 6 hours, as directed in the potassium bromide disk method under Infrared Spectro-

photometry <2.25>, and compare the spectrum with the Reference Spectrum: both spectra exhibit similar intensities of absorption at the same wave numbers.

(3) Dissolve 0.1 g of Iohexol in 10 mL of methanol, and use this solution as the sample solution. Perform the test with the sample solution as directed under Thin-layer Chromatography <2.03>. Spot 10 μL of the sample solution on a plate of silica gel with fluorescent indicator for thin-layer chromatography. Develop the plate with a mixture of 1-butanol, water and acetic acid (100) (50:25:11) to a distance of about 12 cm, and air-dry the plate. Examine under ultraviolet light (main wavelength: 254 nm): the number of principal spots obtained from the sample solutions is two, and their *R_f* values are about 0.2 and about 0.3, respectively.

Purity (1) Clarity and color of solution—A solution obtained by dissolving 1.0 g of Iohexol in 5 mL of water is clear and colorless.

(2) Aromatic primary amine—Conduct this procedure using light-resistant vessels. Dissolve 0.20 g of Iohexol in 15 mL of water, cool in ice for 5 minutes, add 1.5 mL of 6 mol/L hydrochloric acid TS and 1 mL of a solution of sodium nitrite (1 in 50), prepared before use, stir, and cool in ice for 4 minutes. Add 1 mL of a solution of amidosulfuric acid (standard reagent) (1 in 25), stir, and cool in ice for 1 minute. Then, add 0.5 mL of a solution, prepared by dissolving 0.3 g of *N*-1-naphthylethylenediamine dihydrochloride in diluted propylene glycol (7 in 10) to make 100 mL, and add water to make exactly 25 mL. Perform the test with this solution as directed under Ultraviolet-visible Spectrophotometry <2.24> within 20 minutes, using a solution prepared in the same manner with 15 mL of water as the blank: the absorbance at 495 nm is not more than 0.21.

(3) Chloride <1.03>—Perform the test with 2.0 g of Iohexol. Prepare the control solution with 0.40 mL of 0.01 mol/L hydrochloric acid VS (not more than 0.007%).

(4) Iodine and iodide—Dissolve 1.0 g of Iohexol in 4 mL of water, add 1 mL of dilute sulfuric acid, and allow to stand for 10 minutes while occasional shaking. Add 5 mL of chloroform, shake well, and allow to stand: the chloroform layer is colorless. Then, add 1 mL of sodium nitrite solution (1 in 50), prepared before use, shake, allow to stand, and determine the absorbance of collected chloroform layer as directed under Ultraviolet-visible Spectrophotometry <2.24>, using a chloroform layer prepared in the same manner with 4.0 mL of water as the blank: the absorbance at 510 nm is not larger than that of chloroform layer obtained from the following control solution.

Control solution: Dissolve exactly 0.131 g of potassium iodide in water to make exactly 100 mL. Pipet 1 mL of this solution, and add water to make exactly 100 mL. Pipet 3 mL of this solution, add 1 mL of water and 1 mL of dilute sulfuric acid, then proceed in the same manner.

(5) Heavy metals <1.07>—Proceed with 2.0 g of Iohexol according to Method 1, and perform the test. Prepare the control solution with 2.0 mL of Standard Lead Solution (not more than 10 ppm).

(6) 3-Chloro-1,2-propanediol—To exactly 1.0 g of Iohexol, add exactly 2 mL of diethyl ether, and sonicate for 10 minutes under cooling. Centrifuge, and use the diethyl ether layer as the sample solution. Separately, dissolve exactly 0.50 g of 3-chloro-1,2-propanediol in diethyl ether to make exactly 50 mL. Pipet 1 mL of this solution, and add diethyl ether to make exactly 100 mL. Pipet 5 mL of this solution, add diethyl ether to make exactly 25 mL, and use this solution as the standard solution. Perform the test with exactly 5 μL each of the sample solution and standard solution as di-

rected under Gas Chromatography <2.02>, and determine the peak areas, A_T and A_S , of 3-chloro-1,2-propanediol in each solution: A_T is not larger than 2.5 times A_S .

Operating conditions—

Detector: A hydrogen flame-ionization detector.

Column: A fused silica column 0.25 mm in inside diameter and 30 m in length, coated the inside surface with a layer about 0.25 μm thick of 5% diphenyl-95% dimethyl-polysiloxane for gas chromatography.

Column temperature: A constant temperature of about 70°C.

Injection port and detector temperature: A constant temperature of about 230°C.

Carrier gas: Helium.

Flow rate: Adjust so that the retention time of 3-chloro-1,2-propanediol is about 7 minutes.

Split ratio: 1:40.

System suitability—

System performance: To 1 mL of a solution of 3-chloro-1,2-propanediol in diethyl ether (1 in 200) and 1 mL of a solution of 1-hexanol in diethyl ether (1 in 800) add diethyl ether to make 200 mL. When the procedure is run with 5 μL of this solution under the above operating conditions, 1-hexanol and 3-chloro-1,2-propanediol are eluted in this order with the resolution between these peaks being not less than 20.

System repeatability: When the test is repeated 6 times with 5 μL of the standard solution under the above operating conditions, the relative standard deviation of the peak area of 3-chloro-1,2-propanediol is not more than 15%.

(7) Related substance—(i) Dissolve 1.0 g of Iohexol in 10 mL of methanol, and use this solution as the sample solution. Pipet 1 mL of the sample solution, and add methanol to make exactly 25 mL. Pipet 1 mL of this solution, add the methanol to make exactly 20 mL, and use this solution as the standard solution. Perform the test with these solutions as directed under Thin-layer Chromatography <2.03>. Spot 10 μL each of the sample solution and standard solution on a plate of silica gel with fluorescent indicator for thin-layer chromatography. Develop the plate with a mixture of acetone, 2-propanol, ammonia solution (28) and methanol (10:7:4:4) to a distance about 14 cm, and air-dry the plate. Examine under ultraviolet light (main wavelength: 254 nm): a spot, other than the principal spot obtained from the sample solution, having the relative R_f value of 1.4 to the spot from the standard solution, is not more intense than the spot from the standard solution.

(ii) Dissolve 0.15 g of Iohexol in water to make 100 mL, and use this solution as the sample solution. Perform the test with 10 μL of the sample solution as directed under Liquid Chromatography <2.01> according to the following conditions. Determine the peak area by the automatic integration method, and calculate the amounts by the area percentage method: the total amount of *O*-alkyl substances, having the relative retention time between 1.2 and 1.5 to the second principal peak (having bigger retention time) among the two principal peaks of iohexol, is not more than 0.6%, the amount of the peaks, which are eluted after the peak of iohexol and other than *O*-alkyl substances, is not more than 0.1%, respectively, and the total amount of the peaks, which are eluted after iohexol and other than *O*-alkyl substances, is not more than 0.3%.

Operating conditions—

Detector: An ultraviolet absorption photometer (wavelength: 254 nm).

Column: A stainless steel column 4.6 mm in inside diameter and 25 cm in length, packed with octadecylsilanized silica

gel for liquid chromatography (5 μm in particle diameter).

Column temperature: A constant temperature of about 25°C.

Mobile phase A: Acetonitrile.

Mobile phase B: Water.

Flowing of mobile phase: Control the gradient by mixing the mobile phases A and B as directed in the following table.

Time after injection of sample (min)	Mobile phase A (vol%)	Mobile phase B (vol%)
0 - 1	1	99
1 - 46	1 \rightarrow 10	99 \rightarrow 90

Flow rate: Adjust so that the retention time of the second principal peak (iohexol exo-product) is about 19 minutes.

Time span of measurement: About 2 times as long as the retention time of iohexol exo-product.

System suitability—

Test for required detectability: To 1 mL of the sample solution add water to make 50 mL, and use this solution as the solution for system suitability test. Pipet 1 mL of the solution for system suitability test, and add water to make exactly 20 mL. Confirm that the peak area of iohexol exo-product obtained with 10 μL of this solution is equivalent to 3.5 to 6.5% of that with 10 μL of the solution for system suitability test.

System performance: When the procedure is run with 10 μL of the solution for system suitability test under the above operating conditions, the resolution between the adjacent two peaks, which appear at the retention time of about 18 minutes, is not less than 1.5.

System repeatability: When the test is repeated 3 times with 10 μL of the solution for system suitability test under the above operating conditions, the relative standard deviation of the peak area of iohexol exo-product is not more than 3.0%.

Water <2.48> Not more than 4.0% (0.3 g, volumetric titration, direct titration).

Residue on ignition <2.44> Not more than 0.1% (1 g).

Assay Weigh accurately about 0.5 g of Iohexol, dissolve in 25 mL of a solution of sodium hydroxide (1 in 20), add 0.5 g of zinc powder, boil under a reflux condenser for 30 minutes, and filter after cooling. Wash the flask and filter paper with 200 mL of water, combine the washings and filter, add 5 mL of acetic acid (100), and titrate <2.50> with 0.1 mol/L silver nitrate VS (indicator: 1 mL of tetrabromophenolphthalein ethyl ester TS) until the color of the precipitate changes from yellow to green.

Each mL of 0.1 mol/L silver nitrate VS
= 27.37 mg of $\text{C}_{19}\text{H}_{26}\text{I}_3\text{N}_3\text{O}_9$

Containers and storage Containers—Tight containers.

Iohexol Injection

イオヘキソール注射液

Iohexol Injection is an aqueous injection.

It contains not less than 95.0% and not more than 105.0% of the labeled amount of iohexol ($C_{19}H_{26}I_3N_3O_9$; 821.14).

Method of preparation Prepare as directed under Injections, with Iohexol.

Description Iohexol Injection is a clear and colorless liquid.

Identification To a volume of Iohexol Injection, equivalent to 0.65 g of Iohexol, add water to make 500 mL. To 1 mL of this solution add water to make 100 mL, and determine the absorption spectrum of this solution as directed under Ultraviolet-visible Spectrophotometry <2.24>: it exhibits a maximum between 243 nm and 247 nm.

pH Being specified separately when the drug is granted approval based on the Law.

Purity (1) Aromatic primary amine—Conduct this procedure using light-resistant vessels. To a volume of Iohexol Injection, equivalent to 0.20 g of Iohexol add 15 mL of water, cool in ice for 5 minutes, add 1.5 mL of 6 mol/L hydrochloric acid TS and 1 mL of solution of sodium nitrite (1 in 50), prepared before use, shake, and cool in ice for 4 minutes. Then, proceed as directed in the Purity (2) under Iohexol: the absorbance of a solution so obtained is not more than 0.23.

(2) Iodine and iodide—To a volume of Iohexol Injection, equivalent to 1.0 g of Iohexol, add 4 mL of water and 1 mL of dilute sulfuric acid, and allow to stand for 10 minutes while occasional shaking. Then, proceed as directed in the Purity (4) under Iohexol: the absorbance of a chloroform layer so obtained is not more than 0.14.

Bacterial endotoxins <4.01> Less than 0.47 EU/mL.

Extractable volume <6.05> It meets the requirement.

Foreign insoluble matter <6.06> Perform the test according to Method 1: it meets the requirement.

Insoluble particulate matter <6.07> It meets the requirement.

Sterility <4.06> Perform the test according to the Membrane filtration method: it meets the requirement.

Assay To an exactly measured volume of Iohexol Injection, equivalent to about 1.5 g of iohexol ($C_{19}H_{26}I_3N_3O_9$), add water to make exactly 25 mL. Pipet 10 mL of this solution, add 25 mL of a solution of sodium hydroxide (1 in 20) and 0.5 g of zinc powder, and boil under a reflux condenser for 30 minutes. After cooling, wash down the inside of the condenser with 20 mL of water, and filter. Then, proceed as directed in the Assay under Iohexol.

$$\begin{aligned} \text{Each mL of 0.1 mol/L silver nitrate VS} \\ = 27.37 \text{ mg of } C_{19}H_{26}I_3N_3O_9 \end{aligned}$$

Containers and storage Containers—Hermetic containers. Colored containers and plastic containers for aqueous injections may be used.

Iopamidol

イオパミドール

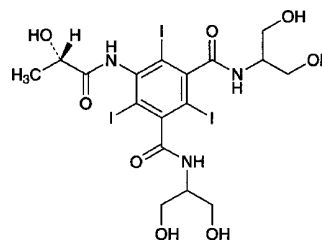

$C_{17}H_{22}I_3N_3O_8$; 777.09

N,N'-Bis[2-hydroxy-1-(hydroxymethyl)ethyl]-5-[(2*S*)-2-hydroxypropanoylamino]-2,4,6-triiodoisophthalamide [62883-00-5]

Iopamidol, when dried, contains not less than 99.0% of iopamidol ($C_{17}H_{22}I_3N_3O_8$).

Description Iopamidol occurs as a white crystalline powder.

It is very soluble in water, sparingly soluble in methanol, and very slightly soluble in ethanol (99.5).

Identification (1) To 50 mg of Iopamidol add 5 mL of hydrochloric acid, heat for 10 minutes in a water bath: the test solution responds to Qualitative Tests <1.09> for primary aromatic amines.

(2) Heat 0.1 g of Iopamidol over a flame: a purple gas is evolved.

(3) Determine the infrared absorption spectrum of Iopamidol, previously dried, as directed in the potassium bromide disk method under Infrared Spectrophotometry <2.25>, and compare the spectrum with the Reference Spectrum: both spectra exhibit similar intensities of absorption at the same wave numbers.

Optical rotation <2.49> $[\alpha]_{436}^{20}$: $-4.6 - -5.2^\circ$ (after drying, 4 g, water, warm, after cooling, 10 mL, 100 mm).

Purity (1) Clarity and color of solution—Dissolve 1.0 g of Iopamidol in 10 mL of water: the solution is clear and colorless.

(2) Primary aromatic amines—Dissolve 0.60 g of Iopamidol in 8 mL of water, add 1 mL of a solution of sodium nitrite (1 in 50) and 12 mL of 2 mol/L hydrochloric acid TS, shake, and allow to stand for 2 minutes. Add 1 mL of a solution of ammonium amidosulfate (1 in 10), shake well, allow to stand for 1 minute, and add 1 mL of naphthylethylenediamine TS and water to make exactly 50 mL. Determine the absorbance of this solution at 495 nm as directed under Ultraviolet-visible Spectrophotometry <2.24> using a solution, prepared in the same manner, as the blank: the absorbance is not more than 0.12 (not more than 0.020%).

(3) Iodine—Dissolve 2.0 g of Iopamidol in 25 mL of water, add 5 mL of 1 mol/L sulfuric acid TS and 5 mL of toluene, shake well, and allow to stand: the toluene layer is colorless.

(4) Free iodine ion—Weigh accurately about 5 g of Iopamidol, dissolve in 70 mL of water, and adjust the pH to about 4.5 with dilute acetic acid. To this solution add 2 mL of 0.1 mol/L sodium chloride TS, and titrate <2.50> with 0.001 mol/L silver nitrate VS (potentiometric titration).

Each mL of 0.001 mol/L silver nitrate VS
= 0.1269 mg of I

Content of iodine ion in Iopamidol is not more than 0.001%.

(5) Heavy metals <1.07>—Moisten 1.0 g of Iopamidol with a small quantity of sulfuric acid, heat gradually to almost incinerate by a possibly lower temperature. After cooling, moisten again with a small quantity of sulfuric acid, heat gradually until white fumes no longer are evolved, and incinerate by ignition between 450 to 550°C. Proceed as directed in Method 2, and perform the test. Prepare the control solution with 1.0 mL of Standard Lead Solution (not more than 10 ppm).

(6) Related substances—Dissolve 0.10 g of Iopamidol in water to make exactly 10 mL, and use this solution as the sample solution. Separately, dissolve 10 mg of *N,N'*-bis[2-hydroxy-1-(hydroxymethyl)ethyl]-5-hydroxyacetylamin-2,4,6-triiodoisophthalamide in water to make exactly 100 mL. Pipet 5 mL of this solution, add water to make exactly 50 mL, and use this solution as the standard solution. Perform the test with exactly 20 μ L each of the sample solution and standard solution as directed under Liquid Chromatography <2.01> according to the following conditions, and determine each peak area of the both solutions by the automatic integration method: each area of the peaks other than the peak of iopamidol from the sample solution is not larger than the peak area of the standard solution, and the total of these areas is not larger than 2.5 times of the peak area of the standard solution.

Operating conditions—

Detector: An ultraviolet absorption photometer (wavelength: 240 nm).

Column: A stainless steel column 4.6 mm in inside diameter and 25 cm in length, packed with octadecylsilylated silica gel for liquid chromatography (5 μ m in particle diameter).

Column temperature: A constant temperature of about 35°C.

Mobile phase A: Water.

Mobile phase B: A mixture of water and methanol (3:1).

Flowing of mobile phase: Control the gradient by mixing the mobile phase A and B as directed in the following table.

Time after injection of sample (min)	Mobile phase A (vol%)	Mobile phase B (vol%)
0 – 6	92	8
6 – 18	92 → 65	8 → 35
18 – 30	65 → 8	35 → 92
30 – 34	8	92

Flow rate: 1.5 mL per minute.

Time span of measurement: About 4.3 times as long as the retention time of iopamidol.

System suitability—

System performance: Dissolve 1 mL of the sample solution and 10 mg of *N,N'*-bis[2-hydroxy-1-(hydroxymethyl)ethyl]-5-hydroxyacetylamin-2,4,6-triiodoisophthalamide in water to make 100 mL. When the procedure is run with 20 μ L of this solution under the above operating conditions, *N,N'*-bis[2-hydroxy-1-(hydroxymethyl)ethyl]-5-hydroxyacetylamin-2,4,6-triiodoisophthalamide and iopamidol are eluted in this order with the resolution between these peaks being not less than 7.

System repeatability: When the test is repeated 6 times with 20 μ L of the standard solution under the above operating conditions, the relative standard deviation of the

peak areas of *N,N'*-bis[2-hydroxy-1-(hydroxymethyl)ethyl]-5-hydroxyacetylamin-2,4,6-triiodoisophthalamide is not more than 1.0%.

Loss on drying <2.41> Not more than 0.30% (1 g, 105°C, 3 hours).

Residue on ignition <2.44> Not more than 0.1% (1 g).

Assay Weigh accurately about 0.5 g of Iopamidol, previously dried, transfer to a saponification flask, dissolve in 40 mL of sodium hydroxide TS, add 1 g of zinc powder, boil for 30 minutes under a reflux condenser, cool, and filter. Wash the flask and the filter paper with 50 mL of water, and combine the washing with the filtrate. Add 5 mL of acetic acid (100) to this solution, and titrate <2.50> with 0.1 mol/L silver nitrate VS (potentiometric titration).

Each mL of 0.1 mol/L silver nitrate VS
= 25.90 mg of $C_{17}H_{22}I_3N_3O_8$

Containers and storage Containers—Well-closed containers.

Storage—Light-resistant.

Iopamidol Injection

イオパミドール注射液

Iopamidol Injection is an aqueous injection.

It contains not less than 95.0% and not more than 105.0% of the labeled amount of iopamidol ($C_{17}H_{22}I_3N_3O_8$; 777.09).

Method of preparation Prepare as directed under Injections, with Iopamidol.

Description Iopamidol Injection occurs as a clear, colorless or faint yellow, liquid, having slight viscosity.

It is gradually colored to faint yellow by light.

Identification (1) To a volume of Iopamidol Injection, equivalent to 0.3 g of Iopamidol, add 0.2 mL of sulfuric acid, and mix. When heat the solution over a flame, the color of the solution changes from colorless to purplish brown, and a purple gas is evolved.

(2) To a volume of Iopamidol Injection, equivalent to 0.6 g of Iopamidol, add water to make 100 mL, and use this solution as the sample solution. Separately, dissolve 60 mg of iopamidol for assay in 10 mL of water, and use this solution as the standard solution. Perform the test with these solutions as directed under Thin-layer Chromatography <2.03>. Spot 4 μ L each of the sample solution and standard solution on a plate of silica gel with fluorescent indicator for thin-layer chromatography. Develop the plate with a mixture of 2-propanol, 2-butanone and ammonia solution (28) (2:2:1) to a distance of about 15 cm, and air-dry the plate. Examine under ultra-violet light (main wavelength: 254 nm): the *R_f* value of the principal spot obtained from the sample solution is the same as that from the standard solution.

pH Being specified separately when the drug is granted approval based on the Law.

Purity (1) Primary aromatic amines—To a volume of Iopamidol Injection, equivalent to 0.18 g of Iopamidol, add 6 mL of water and mix. Add 1 mL of a solution of sodium nitrite (1 in 50) and 12 mL of 2 mol/L hydrochloric acid TS, shake the solution and allow to stand for 2 minutes. Add 1 mL of a solution of ammonium amidosulfate (1 in 10),

shake well, and allow to stand for 1 minute. Add 1 mL of naphthylethylenediamine TS and water to make exactly 50 mL. Determine the absorbance of this solution at 495 nm as directed under Ultraviolet-visible Spectrophotometry <2.24> using a solution prepared in the same manner as the blank: the absorbance is not more than 0.18.

(2) Iodine—Take a volume of Iopamidol Injection, equivalent to 2.0 g of Iopamidol, and add 2 mL of 1 mol/L sulfuric acid TS and 1 mL of toluene. Then shake well and allow to stand: the toluene layer is colorless.

(3) Free iodine ion—To exactly 10 mL of Iopamidol Injection add a suitable amount of water, and adjust the pH to about 4.5 with diluted 0.25 mol/L sulfuric acid TS (1 in 10). Titrate <2.50> with 0.001 mol/L silver nitrate VS (potentiometric titration): the amount of iodine ion contained in Iopamidol Injection is not more than 40 µg per mL.

Each mL of 0.001 mol/L silver nitrate VS = 0.1269 mg of I

Bacterial endotoxins <4.01> Less than 1.5 EU/mL.

Extractable volume <6.05> It meets the requirement.

Foreign insoluble matter <6.06> Perform the test according to Method 1: it meets the requirement.

Insoluble particulate matter <6.07> It meets the requirement.

Sterility <4.06> Perform the test according to the Membrane filtration method: it meets the requirement.

Assay To exactly 1 mL of Iopamidol Injection add water to make exactly 200 mL. Take exactly V mL of this solution, add water to make exactly V' mL so that each mL contains about 80 µg of iopamidol ($C_{17}H_{22}I_3N_3O_8$), and use this solution as the sample solution. Separately, weigh accurately about 20 mg of iopamidol for assay, previously dried at 105°C for 3 hours, and dissolve in water to make exactly 10 mL. Pipet 4 mL of this solution, add water to make exactly 100 mL, and use this solution as the standard solution. Perform the test with exactly 20 µL each of the sample solution and standard solution as directed under Liquid Chromatography <2.01> according to the following conditions, and determine the peak areas, A_T and A_S , of iopamidol in each solution.

$$\begin{aligned} \text{Amount (mg) of iopamidol (C}_{17}\text{H}_{22}\text{I}_3\text{N}_3\text{O}_8) \\ = M_S \times A_T/A_S \times V'/V \times 4/5 \end{aligned}$$

M_S : Amount (mg) of iopamidol for assay taken

Operating conditions—

Detector: An ultraviolet absorption photometer (wavelength: 240 nm).

Column: A stainless steel column 4.6 mm in inside diameter and 25 cm in length, packed with octadecylsilanized silica gel for liquid chromatography (5 µm in particle diameter).

Column temperature: A constant temperature of about 35°C.

Mobile phase A: Water.

Mobile phase B: A mixture of water and methanol (3:1).

Flowing of mobile phase: Control the gradient by mixing the mobile phases A and B as directed in the following table.

Time after injection of sample (min)	Mobile phase A (vol%)	Mobile phase B (vol%)
0 - 6	92	8
6 - 18	92 → 65	8 → 35
18 - 30	65 → 8	35 → 92
30 - 34	8	92

Flow rate: 1.5 mL per minute.

System suitability—

System performance: Dissolve 1 mg each of iopamidol for assay and N,N' -bis[2-hydroxy-1-(hydroxymethyl)ethyl]-5-hydroxyacetyl-amino-2,4,6-triiodoisophthalamide in water to make 100 mL. When the procedure is run with 20 µL of this solution under the above operating conditions, N,N' -bis[2-hydroxy-1-(hydroxymethyl)ethyl]-5-hydroxyacetyl-amino-2,4,6-triiodoisophthalamide and iopamidol are eluted in this order with the resolution between these peaks being not less than 7.

System repeatability: When the test is repeated 6 times with 20 µL of the standard solution under the above operating conditions, the relative standard deviation of the peak area of iopamidol is not more than 1.0%.

Containers and storage Containers—Hermetic containers. Plastic containers for aqueous injections may be used.

Storage—Light-resistant.

Iotalamic Acid

イオタラム酸

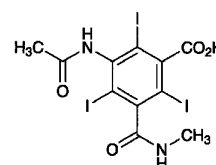

$C_{11}H_9I_3N_2O_4$: 613.91
3-Acetyl-5-(methylaminocarbonyl)benzoic acid
[2276-90-6]

Iotalamic Acid, when dried, contains not less than 99.0% of iotalamic acid ($C_{11}H_9I_3N_2O_4$).

Description Iotalamic Acid occurs as a white powder. It is odorless.

It is sparingly soluble in ethanol (95), very slightly soluble in water, and practically insoluble in diethyl ether.

It dissolves in sodium hydroxide TS.

It gradually colored by light.

Identification (1) Heat 0.1 g of Iotalamic Acid over a flame: a purple gas is evolved.

(2) Determine the infrared spectrum of Iotalamic Acid, previously dried, as directed in the potassium bromide disk method under Infrared Spectrophotometry <2.25>, and compare the spectrum with the Reference Spectrum: both spectra exhibit similar intensities of absorption at the same wave numbers.

Purity (1) Clarity and color of solution—Dissolve 2.0 g of Iotalamic Acid in 10 mL of sodium hydroxide TS: the solution is clear and colorless.

(2) Primary aromatic amines—To 0.50 g of Iotalamic

Acid add 15 mL of water, and dissolve it in 1 mL of sodium hydroxide TS while ice-cooling. Add 4 mL of a solution of sodium nitrite (1 in 100) to the solution, immediately add 12 mL of 1 mol/L hydrochloric acid TS, and shake gently. Then allow the mixture to stand for exactly 2 minutes, add 8 mL of ammonium amidosulfate TS, and shake occasionally for 5 minutes. Add 3 drops of a solution of 1-naphthol in ethanol (95) (1 in 10), allow to stand for 1 minute, add 3.5 mL of ammonia-ammonium chloride buffer solution (pH 10.7), mix, and immediately add water to make 50 mL. Determine within 20 minutes the absorbance of this solution at 485 nm as directed under Ultraviolet-visible Spectrophotometry <2.24>, using a solution, prepared in the same manner, as the blank: the absorbance is not more than 0.25.

(3) Soluble halides—Dissolve 0.5 g of Iotalamic Acid in 20 mL of diluted ammonia TS (1 in 40), add 6 mL of dilute nitric acid, shake, allow to stand for 5 minutes, and filter. Transfer the filtrate to a Nessler tube, wash the residue with 20 mL of water, combine the filtrate and the washings, and add water to make 50 mL. Proceed as directed for Chloride Limit Test <1.03> using this solution as the test solution. Prepare the control solution as follows: to 0.10 mL of 0.01 mol/L hydrochloric acid VS and add 20 mL of diluted ammonia TS (1 in 40), 6 mL of dilute nitric acid and water to make 50 mL.

(4) Iodine—Dissolve 0.20 g of Iotalamic Acid in 2.0 mL of sodium hydroxide TS, add 2.5 mL of 0.5 mol/L sulfuric acid TS, and allow to stand for 10 minutes with occasional shaking. Add 5 mL of chloroform, shake well, and allow to stand: the chloroform layer remains colorless.

(5) Heavy metals <1.07>—Proceed with 1.0 g of Iotalamic Acid according to Method 2, and perform the test. Prepare the control solution with 2.0 mL of Standard Lead Solution (not more than 20 ppm).

(6) Arsenic <1.11>—Prepare the test solution with 0.6 g of Iotalamic Acid according to Method 3, and perform the test (not more than 3.3 ppm).

Loss on drying <2.41> Not more than 0.5% (1 g, 105°C, 4 hours).

Residue on ignition <2.44> Not more than 0.1% (1 g).

Assay Weigh accurately about 0.4 g of Iotalamic Acid, previously dried, place it in a saponification flask, dissolve in 40 mL of sodium hydroxide TS, add 1 g of zinc powder, and heat for 30 minutes under a reflux condenser. Cool, filter, wash the flask and the filter paper with 50 mL of water, and combine the washings and the filtrate. Add 5 mL of acetic acid (100) to this solution, and titrate <2.50> with 0.1 mol/L silver nitrate VS, until the color of the precipitate changes from yellow to green (indicator: 1 mL of tetrabromophenolphthalein ethyl ester TS).

Each mL of 0.1 mol/L silver nitrate VS
= 20.46 mg of $C_{11}H_9I_3N_2O_4$

Containers and storage Containers—Tight containers.
Storage—Light-resistant.

Iotroxic Acid

イオトロクス酸

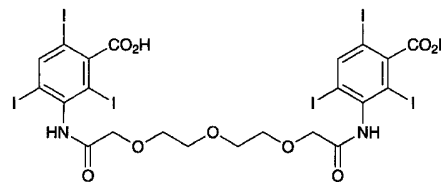

$C_{22}H_{18}I_6N_2O_9$: 1215.81

3,3'-(3,6,9-Trioxaundecanedioyl)diiminobis(2,4,6-triiodobenzoic acid)

[51022-74-3]

Iotroxic Acid contains not less than 98.5% of iotroxic acid ($C_{22}H_{18}I_6N_2O_9$), calculated on the anhydrous basis.

Description Iotroxic Acid occurs as a white crystalline powder.

It is soluble in methanol, slightly soluble in ethanol (95), and practically insoluble in water and in diethyl ether.

It is gradually colored by light.

Identification (1) Heat 0.1 g of Iotroxic Acid over a flame: a purple gas evolves.

(2) Dissolve a suitable amount of Iotroxic Acid in a suitable amount of methanol, evaporate the methanol under reduced pressure, and determine the infrared absorption spectrum of the residue so obtained as directed in the potassium bromide disk method under Infrared Spectrophotometry <2.25>, and compare the spectrum with the Reference Spectrum: both spectra exhibit similar intensities of absorption at the same wave numbers.

Purity (1) Clarity and color of solution—Dissolve 1.0 g of Iotroxic Acid in 10 mL of diluted sodium hydroxide TS (1 in 5): the solution is clear and colorless.

(2) Primary aromatic amines—Dissolve 0.20 g of Iotroxic Acid in 5 mL of water and 1 mL of sodium hydroxide TS, add 4 mL of a solution of sodium nitrite (1 in 100) and 10 mL of 1 mol/L hydrochloric acid TS, mix, and allow to stand for 2 minutes. Add 5 mL of ammonium amidosulfate TS, shake well, allow to stand for 1 minute, then add 0.4 mL of a solution of α -naphthol in ethanol (95) (1 in 10), 15 mL of sodium hydroxide TS and water to make exactly 50 mL. Read the absorbance of this solution at 485 nm as directed under Ultraviolet-visible Spectrophotometry <2.24>, using a blank solution obtained in the same manner as above: the absorbance is not more than 0.22.

(3) Iodine—Dissolve 0.20 g of Iotroxic Acid in 2.0 mL of sodium hydrogen carbonate TS, add 5 mL of toluene, mix well, and allow to stand: the toluene layer is colorless.

(4) Free iodine ion—Weigh accurately about 5.0 g of Iotroxic Acid, dissolve in 12 mL of a solution of meglumine (3 in 20), add water to make 70 mL, and adjust the pH to about 4.5 with acetic acid (100). To this solution add 2 mL of 0.1 mol/L sodium chloride TS, and titrate <2.50> with 0.001 mol/L silver nitrate VS (potentiometric titration).

Each mL of 0.001 mol/L silver nitrate
= 0.1269 mg of I

Content of iodine ion in Iotroxic Acid, calculated on the anhydrous basis, is not more than 0.004%.

(5) Heavy metals <1.07>—Heat strongly 1.0 g of Iotroxic

Acid as directed under Residue on Ignition Test <2.44>, then proceed according to Method 2, and perform the test. Prepare the control solution with 1.0 mL of Standard Lead Solution (not more than 10 ppm).

(6) Related substances—Dissolve 0.15 g of Iotroxic Acid in 10 mL of methanol, and use this solution as the sample solution. Pipet 1 mL of the sample solution, add methanol to make exactly 200 mL, and use this solution as the standard solution. Perform the test with these solutions as directed under Thin-layer Chromatography <2.03>. Spot 10 μ L each of the sample solution and standard solution on a plate of silica gel with fluorescent indicator for thin-layer chromatography. Develop the plate with a mixture of toluene, acetone and formic acid (6:4:1) to a distance of about 15 cm, and air-dry the plate. Examine under ultraviolet light (main wavelength: 254 nm): the spots other than the principal spot obtained from the sample solution are not more intense than the spot from the standard solution.

Water <2.48> 1.0 – 2.0% (0.5 g, volumetric titration, direct titration).

Residue on ignition <2.44> Not more than 0.1% (1 g).

Assay Weigh accurately about 0.5 g of Iotroxic Acid, dissolve in 40 mL of sodium hydroxide TS in a saponification flask, add 1 g of zinc powder, and boil for 30 minutes under a reflux condenser. After cooling, filter, wash the flask and the filter paper with 50 mL of water, and combine the washings to the filtrate. To this solution add 5 mL of acetic acid (100), and titrate <2.50> with 0.1 mol/L silver nitrate VS (potentiometric titration).

Each mL of 0.1 mol/L silver nitrate VS
= 20.26 mg of $C_{22}H_{18}I_6N_2O_9$

Containers and storage Containers—Tight containers.
Storage—Light-resistant.

Ipratropium Bromide Hydrate

イプラトロピウム臭化物水和物

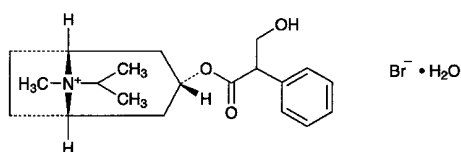

$C_{20}H_{30}BrNO_3 \cdot H_2O$: 430.38
(1*R*,3*r*,5*S*)-3-[(2*RS*)-3-Hydroxy-2-phenylpropanoyloxy]-8-methyl-8-(1-methylethyl)-8-azoniabicyclo[3.2.1]octane bromide monohydrate
[66985-17-9]

Ipratropium Bromide Hydrate, when dried, contains not less than 99.0% of ipratropium bromide ($C_{20}H_{30}BrNO_3$; 412.36).

Description Ipratropium Bromide Hydrate occurs as a white crystalline powder.

It is freely soluble in water, soluble in ethanol (99.5), slightly soluble in acetonitrile and in acetic acid (100), and practically insoluble in diethyl ether.

The pH of a solution of 1.0 g of Ipratropium Bromide Hydrate in 20 mL of water is between 5.0 and 7.5.

Melting point: about 223°C (with decomposition, after drying).

Identification (1) To 5 mg of Ipratropium Bromide Hydrate add 0.5 mL of fuming nitric acid, and evaporate on a water bath to dryness. After cooling, dissolve the residue in 5 mL of acetone, and add 2 drops of potassium hydroxide-ethanol TS: a purple color develops.

(2) Determine the absorption spectrum of a solution of Ipratropium Bromide Hydrate in 0.01 mol/L hydrochloric acid TS (3 in 2000) as directed under Ultraviolet-visible Spectrophotometry <2.24>, and compare the spectrum with the Reference Spectrum: both spectra exhibit similar intensities of absorption at the same wavelengths.

(3) Determine the infrared absorption spectrum of Ipratropium Bromide Hydrate as directed in the potassium bromide disk method under Infrared Spectrophotometry <2.25>, and compare the spectrum with the Reference Spectrum: both spectra exhibit similar intensities of absorption at the same wave numbers.

(4) The solution of Ipratropium Bromide Hydrate (1 in 100) responds to Qualitative Tests <1.09> for bromide.

Purity (1) Clarity and color of solution—Dissolve 1.0 g of Ipratropium Bromide Hydrate in 20 mL of water: the solution is clear and colorless.

(2) Sulfate <1.14>—Perform the test with 1.0 g of Ipratropium Bromide Hydrate. Prepare the control solution with 0.50 mL of 0.005 mol/L sulfuric acid VS (not more than 0.024%).

(3) Heavy metals <1.07>—Proceed with 2.0 g of Ipratropium Bromide Hydrate according to Method 4, and perform the test. Prepare the control solution with 2.0 mL of Standard Lead Solution (not more than 10 ppm).

(4) Arsenic <1.11>—Prepare the test solution with 2.0 g of Ipratropium Bromide Hydrate according to Method 3, and perform the test. Use a solution of magnesium nitrate hexahydrate in ethanol (95) (1 in 10) (not more than 1 ppm).

(5) Isopropylatropine bromide—Dissolve 25 mg of Ipratropium Bromide Hydrate in the mobile phase to make exactly 100 mL, and use this solution as the sample solution. Perform the test with 25 μ L of the sample solution as directed under Liquid Chromatography <2.01> according to the following conditions. Determine the peak area, A_a , of ipratropium and the peak area, A_b , having the relative retention time to ipratropium about 1.3 by the automatic integration method: $A_b/(A_a + A_b)$ is not more than 0.01, and no peak other than the peak of ipratropium and the peak having the relative retention time to ipratropium about 1.3 appears within about 14 minutes of the retention time after the solvent peak.

Operating conditions—

Detector: An ultraviolet absorption photometer (wavelength: 210 nm).

Column: A stainless steel column about 4 mm in inside diameter and 10 to 15 cm in length, packed with octylsilanized silica gel for liquid chromatography (5 μ m in particle diameter).

Column temperature: Room temperature.

Mobile phase: A mixture of diluted phosphoric acid (1 in 200), acetonitrile and methanesulfonic acid (1000:120:1).

Flow rate: Adjust so that the retention time of ipratropium is about 7 minutes.

Selection of column: Heat a solution of Ipratropium Bromide Hydrate in 1 mol/L hydrochloric acid TS (1 in 100) at 100°C for 1 hour, and cool. To 2.5 mL of this solution add the mobile phase to make 100 mL. Proceed with 25 μ L of this solution under the above operating conditions, and calculate the resolution. Use a column showing a resolution not less than 3 between the peak of ipratropium and the peak

having the relative retention time to ipratropium about 0.6.

Detection sensitivity: Adjust so that the peak height of ipratropium obtained with 25 μL of the sample solution composes 50 to 80% of the full scale.

(6) Apo-compounds—Dissolve 0.14 g of Ipratropium Bromide Hydrate in 0.01 mol/L hydrochloric acid TS to make 100 mL. Perform the test with this solution as directed under Ultraviolet-visible Spectrophotometry <2.24>, and determine the absorbances, A_1 and A_2 , at 246 nm and 263 nm, respectively: A_1/A_2 is not more than 0.91.

Loss on drying <2.41> 3.9 – 4.4% (1 g, 105°C, 4 hours).

Residue on ignition <2.44> Not more than 0.1% (1 g).

Assay Weigh accurately about 0.3 g of Ipratropium Bromide Hydrate, previously dried, dissolve in 40 mL of acetic acid (100), add 40 mL of 1,4-dioxane and 2.5 mL of bismuth nitrate TS, and titrate <2.50> with 0.1 mol/L perchloric acid VS (potentiometric titration). Perform a blank determination in the same manner, and make any necessary correction.

Each mL of 0.1 mol/L perchloric acid VS
= 41.24 mg of $\text{C}_{20}\text{H}_{30}\text{BrNO}_3$

Containers and storage Containers—Tight containers.

Ipriflavone

イプリフラボン

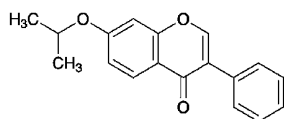

$\text{C}_{18}\text{H}_{16}\text{O}_3$: 280.32

7-(1-Methylethyl)oxy-3-phenyl-4*H*-chromen-4-one
[35212-22-7]

Ipriflavone, when dried, contains not less than 98.5% and not more than 101.0% of ipriflavone ($\text{C}_{18}\text{H}_{16}\text{O}_3$).

Description Ipriflavone occurs as white to yellowish white, crystals or crystalline powder.

It is soluble in acetonitrile, sparingly soluble in methanol and in ethanol (99.5), and practically insoluble in water.

It gradually turns yellow on exposure to light.

Identification (1) Determine the absorption spectrum of a solution of Ipriflavone in methanol (1 in 200,000) as directed under Ultraviolet-visible Spectrophotometry <2.24>, and compare the spectrum with the Reference Spectrum or the spectrum of a solution of Ipriflavone RS prepared in the same manner as the sample solution: both spectra exhibit similar intensities of absorption at the same wavelengths.

(2) Determine the infrared absorption spectrum of Ipriflavone as directed in the potassium bromide disk method under Infrared Spectrophotometry <2.25>, and compare the spectrum with the Reference Spectrum or the spectrum of Ipriflavone RS: both spectra exhibit similar intensities of absorption at the same wave numbers.

Melting point <2.60> 116 – 119°C

Purity (1) Heavy metals <1.07>—Proceed with 1.0 g of Ipriflavone according to Method 2, and perform the test. Prepare the control solution with 1.0 mL of Standard Lead

Solution (not more than 10 ppm).

(2) Arsenic <1.11>—Prepare the test solution with 1.0 g of Ipriflavone according to Method 4, and perform the test. Prepare the test solution with 10 mL of dilute hydrochloric acid instead of using 3 mL of hydrochloric acid. Prepare the standard color with 1.0 mL of Standard Arsenic Solution (not more than 1 ppm).

(3) Related substances—Dissolve 30 mg of Ipriflavone in 50 mL of acetonitrile. To 5 mL of this solution add acetonitrile to make 50 mL, and use this solution as the sample solution. Pipet 1 mL of this solution, add acetonitrile to make exactly 100 mL, and use this solution as the standard solution. Perform the test with exactly 20 μL each of the sample solution and standard solution as directed under Liquid Chromatography <2.01> according to the following conditions. Determine each peak area of both solutions by the automatic integration method: the area of each peak other than the peak of ipriflavone obtained from the sample solution is not larger than 1/2 times the peak area of ipriflavone from the standard solution, and the total area of the peaks other than the peak of ipriflavone from the sample solution is not larger than the peak area of ipriflavone from the standard solution.

Operating conditions—

Detector, column, column temperature, mobile phase and flow rate: Proceed as directed in the operating conditions in the Assay.

Time span of measurement: About 2 times as long as the retention time of ipriflavone, beginning after the solvent peak.

System suitability—

Test for required detectability: Pipet 2 mL of the standard solution, and add acetonitrile to make exactly 20 mL. Confirm that the peak area of ipriflavone obtained with 20 μL of this solution is equivalent to 7 to 13% of that with 20 μL of the standard solution.

System performance: When the procedure is run with 20 μL of the standard solution under the above operating conditions, the number of theoretical plates and the symmetry factor of the peak of ipriflavone are not less than 2000 and not more than 1.5, respectively.

System repeatability: When the test is repeated 6 times with 20 μL of the standard solution under the above operating conditions, the relative standard deviation of the ratio of the peak area of ipriflavone to that of the internal standard is not more than 2.0%.

Loss on drying <2.41> Not more than 0.5% (1 g, 105°C, 2 hours).

Residue on ignition <2.44> Not more than 0.1% (1 g).

Assay Weigh accurately about 30 mg each of Ipriflavone and Ipriflavone RS, previously dried, dissolve separately in acetonitrile to make exactly 50 mL. Pipet 5 mL each of these solutions, add exactly 5 mL of the internal standard solution and acetonitrile to make 50 mL, and use these solutions as the sample solution and the standard solution, respectively. Perform the test with 20 μL each of the sample solution and standard solution as directed under Liquid Chromatography <2.01> according to the following conditions, and calculate the ratios, Q_T and Q_S , of the peak area of ipriflavone to that of the internal standard.

$$\begin{aligned} &\text{Amount (mg) of ipriflavone (C}_{18}\text{H}_{16}\text{O}_3) \\ &= M_S \times Q_T/Q_S \end{aligned}$$

M_S : Amount (mg) of Ipriflavone RS taken

Internal standard solution—A solution of di-*n*-butyl phtha-

late in acetonitrile (1 in 100).

Operating conditions—

Detector: An ultraviolet absorption photometer (wavelength: 280 nm).

Column: A stainless steel column 4 mm in inside diameter and 15 cm in length, packed with octylsilanized silica gel for liquid chromatography (5 μ m in particle diameter).

Column temperature: A constant temperature of about 25°C.

Mobile phase: A mixture of acetonitrile and water (3:2).

Flow rate: Adjust so that the retention time of ipriflavone is about 6 minutes.

System suitability—

System performance: When the procedure is run with 20 μ L of the standard solution under the above operating conditions, ipriflavone and the internal standard are eluted in this order with the resolution between these peaks being not less than 3.

System repeatability: When the test is repeated 6 times with 20 μ L of the standard solution under the above operating conditions, the relative standard deviation of the ratio of the peak area of ipriflavone to that of the internal standard is not more than 1.0%.

Containers and storage Containers—Tight containers.

Storage—Light-resistant.

Ipriflavone Tablets

イプリフラボン錠

Ipriflavone Tablets contain not less than 95.0% and not more than 105.0% of the labeled amount of ipriflavone (C₁₈H₁₆O₃; 280.32).

Method of preparation Prepare as directed under Tablets, with Ipriflavone.

Identification To a quantity of powdered Ipriflavone Tablets, equivalent to 11 mg of Ipriflavone, add 100 mL of methanol, shake vigorously for 10 minutes, and centrifuge. To 5 mL of the supernatant liquid add methanol to make 100 mL. Determine the absorption spectrum of this solution as directed under Ultraviolet-visible Spectrophotometry <2.24>: it exhibits maxima between 247 nm and 251 nm, and between 297 nm and 301 nm.

Uniformity of dosage units <6.02> It meets the requirement of the Mass variation test.

Dissolution Being specified separately when the drug is granted approval based on the Law.

Assay Weigh accurately the mass of not less than 20 Ipriflavone Tablets, and powder. Weigh accurately a portion of the powder, equivalent to about 30 mg of ipriflavone (C₁₈H₁₆O₃), add 30 mL of acetonitrile, shake vigorously for 15 minutes, add acetonitrile to make exactly 50 mL, and centrifuge. Pipet 5 mL of the supernatant liquid, add exactly 5 mL of the internal standard solution, and add acetonitrile to make 50 mL, and use this solution as the sample solution. Separately, weigh accurately about 30 mg of Ipriflavone RS, previously dried at 105°C for 2 hours, and dissolve in acetonitrile to make exactly 50 mL. Pipet 5 mL of this solution, add exactly 5 mL of the internal standard solution, and add acetonitrile to make 50 mL, and use this solution as the standard solution. Proceed as directed in the Assay under Ipriflavone.

$$\begin{aligned} &\text{Amount (mg) of ipriflavone (C}_{18}\text{H}_{16}\text{O}_3) \\ &= M_S \times Q_T/Q_S \end{aligned}$$

M_S : Amount (mg) of Ipriflavone RS taken

Internal standard solution—A solution of di-*n*-butyl phthalate in acetonitrile (1 in 100).

Containers and storage Containers—Tight containers.

Storage—Light-resistant.

Irbesartan

イルベサルタン

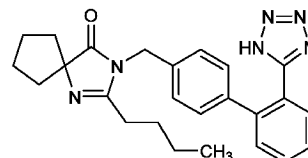

C₂₅H₂₈N₆O: 428.53

2-Butyl-3-[[2'-(1*H*-tetrazol-5-yl)biphenyl-4-yl]methyl]-1,3-diazaspiro[4.4]non-1-en-4-one
[138402-11-6]

Irbesartan contains not less than 99.0% and not more than 101.0% of irbesartan (C₂₅H₂₈N₆O), calculated on the anhydrous basis.

Description Irbesartan occurs as a white crystalline powder.

It is freely soluble in acetic acid (100), sparingly soluble in methanol, slightly soluble in ethanol (99.5) and practically insoluble in water.

It shows crystal polymorphism.

Identification (1) Determine the absorption spectrum of a solution of Irbesartan in methanol (1 in 100,000) as directed under Ultraviolet-visible Spectrophotometry <2.24>, and compare the spectrum with the Reference Spectrum: both spectra exhibit similar intensities of absorption at the same wavelengths.

(2) Determine the infrared absorption spectrum of Irbesartan as directed in the potassium bromide disk method under Infrared Spectrophotometry <2.25>, and compare the spectrum with the Reference Spectrum: both spectra exhibit similar intensities of absorption at the same wave numbers. If any difference appears between the spectra, dissolve the Irbesartan in methanol, evaporate the solvent, dry the residue, and perform the test using the residue.

Purity (1) Heavy metals <1.07>—Proceed with 1.0 g of Irbesartan according to Method 4, and perform the test. Prepare the control solution with 2.0 mL of Standard Lead Solution (not more than 20 ppm).

(2) Related substances—Dissolve 50 mg of Irbesartan in 50 mL of methanol, and use this solution as the sample solution. Pipet 1 mL of the sample solution, and add methanol to make exactly 20 mL. Pipet 1 mL of this solution, add methanol to make exactly 50 mL, and use this solution as the standard solution. Perform the test with exactly 10 μ L each of the sample solution and standard solution as directed under Liquid Chromatography <2.01> according to the following conditions. Determine each peak area by the automatic integration method: the area of the peak, having a relative retention time of about 0.8 to irbesartan, obtained from the sample solution is not larger than 1.5 times the

peak area of irbesartan from the standard solution, the area of the peak other than irbesartan and the peak mentioned above from the sample solution is not larger than the peak area of irbesartan from the standard solution, and the total area of the peaks other than irbesartan from the sample solutions is not larger than 2 times the peak area of irbesartan from the standard solution.

Operating conditions—

Detector: An ultraviolet absorption photometer (wavelength: 220 nm).

Column: A stainless steel column 4.0 mm in inside diameter and 25 cm in length, packed with octadecylsilanized silica gel for liquid chromatography (5 μm in particle diameter).

Column temperature: A constant temperature of about 25°C.

Mobile phase: To 5.5 mL of phosphoric acid add 950 mL of water, and adjust to pH 3.2 with triethylamine. To 670 mL of this solution add 330 mL of acetonitrile for liquid chromatography.

Flow rate: 1.0 mL per minute.

Time span of measurement: About 1.4 times as long as the retention time of irbesartan, beginning after the solvent peak.

System suitability—

Test for required detectability: Pipet 5 mL of the standard solution, and add methanol to make exactly 10 mL. Confirm that the peak area of irbesartan obtained with 10 μL of this solution is equivalent to 35 to 65% of that with 10 μL of the standard solution.

System performance: When the procedure is run with 10 μL of the standard solution under the above operating conditions, the number of theoretical plates and the symmetry factor of the peak of irbesartan are not less than 5000 and not more than 1.5, respectively.

System repeatability: When the test is repeated 6 times with 10 μL of the standard solution under the above operating conditions, the relative standard deviation of the peak area of irbesartan is not more than 3.0%.

(3) Azides—Being specified separately when the drug is granted approval based on the Law.

Water <2.48> Not more than 0.5% (1 g, volumetric titration, back titration).

Residue on ignition <2.44> Not more than 0.1% (1 g).

Assay Weigh accurately about 0.3 g of Irbesartan, dissolve in 50 mL of acetic acid (100), and titrate <2.50> with 0.1 mol/L perchloric acid VS (potentiometric titration). Perform a blank determination in the same manner, and make any necessary correction.

$$\begin{aligned} \text{Each mL of 0.1 mol/L perchloric acid VS} \\ = 42.85 \text{ mg of } \text{C}_{25}\text{H}_{28}\text{N}_6\text{O} \end{aligned}$$

Containers and storage Containers—Tight containers.

Irbesartan Tablets

イルベサルタン錠

Irbesartan Tablets contain not less than 95.0% and not more than 105.0% of the labeled amount of irbesartan ($\text{C}_{25}\text{H}_{28}\text{N}_6\text{O}$: 428.53).

Method of preparation Prepare as directed under Tablets, with Irbesartan.

Identification To a quantity of powdered Irbesartan

Tablets, equivalent to about 25 mg of Irbesartan, add 2 mL of acetone, shake, and filter through a membrane filter with a pore size not exceeding 0.45 μm . Evaporate the filtrate to dryness, and determine the infrared absorption spectrum of the residue as directed in the potassium bromide disk method under Infrared Spectrophotometry <2.25>: it exhibits absorptions at the wave numbers of about 1733 cm^{-1} , 1617 cm^{-1} , 1435 cm^{-1} and 758 cm^{-1} .

Uniformity of dosage unit <6.02> Perform the Mass variation test, or the Content uniformity test according to the following method: it meets the requirement.

To 1 tablet of Irbesartan Tablets add 1.5 mL of water, shake vigorously to disintegrate, and add 15 mL of methanol. Shake vigorously for 15 minutes, add methanol to make exactly 20 mL, and centrifuge. Pipet V mL of the supernatant liquid, equivalent to about 20 mg of irbesartan ($\text{C}_{25}\text{H}_{28}\text{N}_6\text{O}$), and add a mixture of water and acetonitrile for liquid chromatography (3:2) to make exactly 20 mL. Pipet 2.5 mL of this solution, add a mixture of water and acetonitrile for liquid chromatography (3:2) to make exactly 20 mL, and use this solution as the sample solution. Then, proceed as directed in the Assay.

$$\begin{aligned} \text{Amount (mg) of irbesartan (C}_{25}\text{H}_{28}\text{N}_6\text{O)} \\ = M_S \times A_T/A_S \times 16/V \end{aligned}$$

M_S : Amount (mg) of irbesartan for assay taken, calculated on the anhydrous basis

Dissolution <6.10> When the test is performed at 50 revolutions per minute according to the Paddle method, using 900 mL of 2nd fluid for dissolution test as the dissolution medium, the dissolution rate in 45 minutes of 50-mg and 100-mg tablets is not less than 85%, respectively, and that in 60 minutes of a 200-mg tablet is not less than 70%.

Start the test with 1 tablet of Irbesartan Tablets, withdraw not less than 10 mL of the medium at the specified minute after starting the test, and filter through a membrane filter with a pore size not exceeding 0.45 μm . Discard not less than 3 mL of the first filtrate, pipet V mL of the subsequent filtrate, add the dissolution medium to make exactly V' mL so that each mL contains about 22 μg of irbesartan ($\text{C}_{25}\text{H}_{28}\text{N}_6\text{O}$), and use this solution as the sample solution. Separately, weigh accurately about 44 mg of irbesartan for assay (separately determine the water <2.48> in the same manner as Irbesartan), and dissolve in methanol to make exactly 20 mL. Pipet 2 mL of this solution, add the dissolution medium to make exactly 200 mL, and use this solution as the standard solution. Determine the absorbances, A_T and A_S , of the sample solution and standard solution at 244 nm as directed under Ultraviolet-visible Spectrophotometry <2.24>, using the dissolution medium as the control.

$$\begin{aligned} \text{Dissolution rate (\%)} \text{ with respect to the labeled amount} \\ \text{of irbesartan (C}_{25}\text{H}_{28}\text{N}_6\text{O)} \\ = M_S \times A_T/A_S \times V'/V \times 1/C \times 45 \end{aligned}$$

M_S : Amount (mg) of irbesartan for assay taken, calculated on the anhydrous basis

C : Labeled amount (mg) of irbesartan ($\text{C}_{25}\text{H}_{28}\text{N}_6\text{O}$) in 1 tablet

Assay To 10 Irbesartan Tablets add 15 mL of water, shake vigorously to disintegrate, and add 150 mL of methanol. Shake vigorously for 15 minutes, add methanol to make exactly 200 mL, and centrifuge. Pipet V mL of the supernatant liquid, equivalent to about 20 mg of irbesartan ($\text{C}_{25}\text{H}_{28}\text{N}_6\text{O}$), and add a mixture of water and acetonitrile for liquid chromatography (3:2) to make exactly 20 mL. Pipet

2.5 mL of this solution, add a mixture of water and acetonitrile for liquid chromatography (3:2) to make exactly 20 mL, and use this solution as the sample solution. Separately, weigh accurately about 25 mg of irbesartan for assay (separately determine the water <2.48> in the same manner as Irbesartan), and dissolve in methanol to make exactly 10 mL. Pipet 2.5 mL of this solution, add a mixture of water and acetonitrile for liquid chromatography (3:2) to make exactly 50 mL, and use this solution as the standard solution. Perform the test with exactly 15 μ L each of the sample solution and standard solution as directed under Liquid Chromatography <2.01> according to the following conditions, and determine the peak areas, A_T and A_S , of irbesartan in each solution.

$$\begin{aligned} &\text{Amount (mg) of irbesartan (C}_{25}\text{H}_{28}\text{N}_6\text{O) in 1 tablet} \\ &= M_S \times A_T/A_S \times 16/V \end{aligned}$$

M_S : Amount (mg) of irbesartan for assay taken, calculated on the anhydrous basis

Operating conditions—

Detector: An ultraviolet absorption photometer (wavelength: 220 nm).

Column: A stainless steel column 4.6 mm in inside diameter and 25 cm in length, packed with octadecylsilanized silica gel for liquid chromatography (5 μ m in particle diameter).

Column temperature: A constant temperature of about 25°C.

Mobile phase: To 5.5 mL of phosphoric acid add 950 mL of water, adjust to pH 3.0 with triethylamine, and add water to make 1000 mL. To 3 volume of this solution add 2 volume of acetonitrile for liquid chromatography.

Flow rate: Adjust so that the retention time of irbesartan is about 13 minutes.

System suitability—

System performance: When the procedure is run with 15 μ L of the standard solution under the above operating conditions, the number of theoretical plates and the symmetry factor of the peak of irbesartan are not less than 10,000 and not more than 1.5, respectively.

System repeatability: When the test is repeated 6 times with 15 μ L of the standard solution under the above operating conditions, the relative standard deviation of the peak area of irbesartan is not more than 1.0%.

Containers and storage Containers—Tight containers.

Irbesartan and Amlodipine Besilate Tablets

イルベサルタン・アムロジピンベシル酸塩錠

Irbesartan and Amlodipine Besilate Tablets contain not less than 95.0% and not more than 105.0% of the labeled amount of irbesartan (C₂₅H₂₈N₆O: 428.53) and amlodipine besilate (C₂₀H₂₅ClN₂O₅·C₆H₆O₃S: 567.05).

Method of preparation Prepare as directed under Tablets, with Irbesartan and Amlodipine Besilate.

Identification (1) Perform the test with 5 μ L each of the sample solution and standard solution obtained in the Assay (1) as directed under Liquid Chromatography <2.01> according to the following conditions: the retention time of the peak of irbesartan in the chromatogram from the sample solution is the same with that of the principal peak in the chromatogram from the standard solution, and both absorption

spectra of these peaks exhibit similar intensities of absorption at the same wavelengths.

Operating conditions—

Column, column temperature, mobile phase and flow rate: Proceed as directed in the operating conditions in the Assay (1).

Detector: A photodiode array detector (wavelength: 237 nm, spectrum range of measurement: 210 – 400 nm).

System suitability—

System performance: Proceed as directed in the system suitability in the Assay (1).

(2) Perform the test with 5 μ L each of the sample solution and standard solution obtained in the Assay (2) as directed under Liquid Chromatography <2.01> according to the following conditions: the retention time of the peak of amlodipine in the chromatogram from the sample solution is the same with that of the principal peak in the chromatogram from the standard solution, and both absorption spectra of these peaks exhibit similar intensities of absorption at the same wavelengths.

Operating conditions—

Column, column temperature, mobile phase and flow rate: Proceed as directed in the operating conditions in the Assay (1).

Detector: A photodiode array detector (wavelength: 237 nm, spectrum range of measurement: 210 – 400 nm).

System suitability—

System performance: Proceed as directed in the system suitability in the Assay (2).

Uniformity of dosage unit <6.02> (1) Irbesartan—Perform the Mass variation test, or the Content uniformity test according to the following method: it meets the requirement.

To 1 tablet of Irbesartan and Amlodipine Besilate Tablets add 4 mL of 0.02 mol/L phosphate buffer solution (pH 3.0), and sonicate. Add 16 mL of methanol, shake vigorously until the tablet is disintegrated completely, and add the mobile phase to make exactly 100 mL. Pipet V mL of this solution, add the mobile phase to make exactly V' mL so that each mL contains about 1 mg of irbesartan (C₂₅H₂₈N₆O), and filter through a membrane filter with a pore size not exceeding 0.45 μ m. Discard the first 5 mL of the filtrate, and use the subsequent filtrate as the sample solution. Then, proceed as directed under the Assay (1).

$$\begin{aligned} &\text{Amount (mg) of irbesartan (C}_{25}\text{H}_{28}\text{N}_6\text{O)} \\ &= M_S \times A_T/A_S \times V'/V \times 2 \end{aligned}$$

M_S : Amount (mg) of irbesartan for assay taken, calculated on the anhydrous basis

(2) Amlodipine besilate—Perform the test according to the following method: it meets the requirement of the Content uniformity test.

To 1 tablet of Irbesartan and Amlodipine Besilate Tablets add 4 mL of 0.02 mol/L phosphate buffer solution (pH 3.0), and sonicate. Add 16 mL of methanol, shake vigorously until the tablet is disintegrated completely, and add the mobile phase to make exactly 100 mL. Pipet V mL of this solution, add the mobile phase to make exactly V' mL so that each mL contains about 69 μ g of amlodipine besilate (C₂₀H₂₅ClN₂O₅·C₆H₆O₃S), and filter through a membrane filter with a pore size not exceeding 0.45 μ m. Discard the first 5 mL of the filtrate, and use the subsequent filtrate as the sample solution. Then, proceed as directed under the Assay (2).

$$\begin{aligned} &\text{Amount (mg) of amlodipine besilate} \\ &\text{(C}_{20}\text{H}_{25}\text{ClN}_2\text{O}_5\cdot\text{C}_6\text{H}_6\text{O}_3\text{S)} \\ &= M_S \times A_T/A_S \times V'/V \times 1/5 \end{aligned}$$

M_S : Amount (mg) of Amlodipine Besilate RS taken, calculated on the anhydrous basis

Dissolution <6.10> (1) Irbesartan—When the test is performed at 50 revolutions per minute according to the Paddle method, using 900 mL of 2nd fluid for dissolution test as the dissolution medium, the dissolution rate in 30 minutes of Irbesartan and Amlodipine Besilate Tablets is not less than 70%.

Start the test with 1 tablet of Irbesartan and Amlodipine Besilate Tablets, withdraw not less than 15 mL of the medium at the specified minute after starting the test, and filter through a membrane filter with a pore size not exceeding 0.45 μm . Discard not less than 10 mL of the first filtrate, pipet V mL of the subsequent filtrate, and add the mobile phase to make exactly V' mL so that each mL contains about 0.11 mg of irbesartan ($\text{C}_{25}\text{H}_{28}\text{N}_6\text{O}$). Pipet 2 mL of this solution, add exactly 2 mL of the mobile phase, and use this solution as the sample solution. Separately, weigh accurately about 20 mg of irbesartan for assay (separately determine the water <2.48> in the same manner as Irbesartan), dissolve in the mobile phase to make exactly 25 mL, and use this solution as the irbesartan standard stock solution. Pipet 7 mL of the irbesartan standard stock solution, and add the mobile phase to make exactly 50 mL. Pipet 5 mL of this solution, add exactly 5 mL of the dissolution medium, and use this solution as the standard solution. Perform the test with exactly 10 μL each of the sample solution and standard solution as directed under Liquid Chromatography <2.01> according to the following conditions, and determine the peak areas, A_T and A_S , of irbesartan in each solution.

Dissolution rate (%) with respect to the labeled amount of irbesartan ($\text{C}_{25}\text{H}_{28}\text{N}_6\text{O}$)

$$= M_S \times A_T/A_S \times V'/V \times 1/C \times 504$$

M_S : Amount (mg) of irbesartan for assay taken, calculated on the anhydrous basis

C : Labeled amount (mg) of irbesartan ($\text{C}_{25}\text{H}_{28}\text{N}_6\text{O}$) in 1 tablet

Operating conditions—

Proceed as directed in the operating conditions in the Assay (1).

System suitability—

System performance: To 7 mL of the irbesartan standard stock solution and 5 mL of the amlodipine besilate standard stock solution obtained in (2) add the mobile phase to make 50 mL. To 5 mL of this solution add 5 mL of the dissolution medium. When the procedure is run with 10 μL of this solution under the above operating conditions, amlodipine and irbesartan are eluted in this order with the resolution between these peaks being not less than 5.

System repeatability: When the test is repeated 6 times with 10 μL of the standard solution under the above operating conditions, the relative standard deviation of the peak area of irbesartan is not more than 2.0%.

(2) Amlodipine besilate—When the test is performed at 50 revolutions per minute according to the Paddle method, using 900 mL of 2nd fluid for dissolution test as the dissolution medium, the dissolution rate in 30 minutes of Irbesartan and Amlodipine Besilate Tablets is not less than 75%.

Start the test with 1 tablet of Irbesartan and Amlodipine Besilate Tablets, withdraw not less than 15 mL of the medium at the specified minute after starting the test, and filter through a membrane filter with a pore size not exceeding 0.45 μm . Discard not less than 10 mL of the first filtrate, pipet V mL of the subsequent filtrate, and add the mobile phase to make exactly V' mL so that each mL contains about

7.7 μg of amlodipine besilate ($\text{C}_{20}\text{H}_{25}\text{ClN}_2\text{O}_5 \cdot \text{C}_6\text{H}_6\text{O}_3\text{S}$). Pipet 2 mL of this solution, add exactly 2 mL of the mobile phase, and use this solution as the sample solution. Separately, weigh accurately about 26 mg of Amlodipine Besilate RS (separately determine the water <2.48> in the same manner as Amlodipine Besilate), and dissolve in the mobile phase to make exactly 50 mL. Pipet 15 mL of this solution, add the mobile phase to make exactly 100 mL, and use this solution as the amlodipine besilate standard stock solution. Pipet 5 mL of the amlodipine besilate standard stock solution, and add the mobile phase to make exactly 50 mL. Pipet 5 mL of this solution, add exactly 5 mL of the dissolution medium, and use this solution as the standard solution. Perform the test with exactly 10 μL each of the sample solution and standard solution as directed under Liquid Chromatography <2.01> according to the following conditions, and determine the peak areas, A_T and A_S , of amlodipine in each solution.

Dissolution rate (%) with respect to the labeled amount of amlodipine besilate ($\text{C}_{20}\text{H}_{25}\text{ClN}_2\text{O}_5 \cdot \text{C}_6\text{H}_6\text{O}_3\text{S}$)

$$= M_S \times A_T/A_S \times V'/V \times 1/C \times 27$$

M_S : Amount (mg) of Amlodipine Besilate RS taken, calculated on the anhydrous basis

C : Labeled amount (mg) of amlodipine besilate ($\text{C}_{20}\text{H}_{25}\text{ClN}_2\text{O}_5 \cdot \text{C}_6\text{H}_6\text{O}_3\text{S}$) in 1 tablet

Operating conditions—

Proceed as directed in the operating conditions in the Assay (1).

System suitability—

System performance: To 7 mL of the irbesartan standard stock solution obtained in (1) and 5 mL of the amlodipine besilate standard stock solution add the mobile phase to make 50 mL. To 5 mL of this solution add 5 mL of the dissolution medium. When the procedure is run with 10 μL of this solution under the above operating conditions, amlodipine and irbesartan are eluted in this order with the resolution between these peaks being not less than 5.

System repeatability: When the test is repeated 6 times with 10 μL of the standard solution under the above operating conditions, the relative standard deviation of the peak area of amlodipine is not more than 2.0%.

Assay (1) Irbesartan—To 10 tablets of Irbesartan and Amlodipine Besilate Tablets add 20 mL of 0.02 mol/L phosphate buffer solution (pH 3.0), and sonicate. Add 120 mL of methanol, shake vigorously until the tablets are disintegrated completely, and add the mobile phase to make exactly 200 mL. Pipet V mL of this solution, add the mobile phase to make exactly V' mL so that each mL contains about 1 mg of irbesartan ($\text{C}_{25}\text{H}_{28}\text{N}_6\text{O}$), and filter through a membrane filter with a pore size not exceeding 0.45 μm . Discard the first 5 mL of the filtrate, and use the subsequent filtrate as the sample solution. Separately, weigh accurately about 50 mg of irbesartan for assay (separately determine the water <2.48> in the same manner as Irbesartan), dissolve in methanol to make exactly 25 mL, and use this solution as the irbesartan standard stock solution. Pipet 10 mL of the irbesartan standard stock solution, add 2 mL of methanol, add 0.02 mol/L phosphate buffer solution (pH 3.0) to make exactly 20 mL, and use this solution as the standard solution. Perform the test with exactly 5 μL each of the sample solution and standard solution as directed under Liquid Chromatography <2.01> according to the following conditions, and determine the peak areas, A_T and A_S , of irbesartan in each solution.

Amount (mg) of irbesartan ($\text{C}_{25}\text{H}_{28}\text{N}_6\text{O}$) in 1 tablet

$$= M_S \times A_T/A_S \times V'/V \times 2/5$$

M_S : Amount (mg) of irbesartan for assay taken, calculated on the anhydrous basis

Operating conditions—

Detector: An ultraviolet absorption photometer (wavelength: 237 nm).

Column: A stainless steel column 3.0 mm in inside diameter and 75 mm in length, packed with octadecylsilanized silica gel for liquid chromatography (2.2 μ m in particle diameter).

Column temperature: A constant temperature of about 40°C.

Mobile phase: A mixture of methanol and 0.02 mol/L phosphate buffer solution (pH 3.0) (3:2).

Flow rate: Adjust so that the retention time of irbesartan is about 3 minutes.

System suitability—

System performance: To 10 mL of the irbesartan standard stock solution and 2 mL of the amlodipine besilate standard stock solution obtained in (2) add 0.02 mol/L phosphate buffer solution (pH 3.0) to make 20 mL. When the procedure is run with 5 μ L of this solution under the above operating conditions, amlodipine and irbesartan are eluted in this order with the resolution between these peaks being not less than 5.

System repeatability: When the test is repeated 6 times with 5 μ L of the standard solution under the above operating conditions, the relative standard deviation of the peak area of irbesartan is not more than 1.0%.

(2) Amlodipine besilate—To 10 tablets of Irbesartan and Amlodipine Besilate Tablets add 20 mL of 0.02 mol/L phosphate buffer solution (pH 3.0), and sonicate. Add 120 mL of methanol, shake vigorously until the tablets are disintegrated completely, and add the mobile phase to make exactly 200 mL. Pipet V mL of this solution, add the mobile phase to make exactly V' mL so that each mL contains about 69 μ g of amlodipine besilate ($C_{20}H_{25}ClN_2O_5 \cdot C_6H_6O_3S$), and filter through a membrane filter with a pore size not exceeding 0.45 μ m. Discard the first 5 mL of the filtrate, and use the subsequent filtrate as the sample solution. Separately, weigh accurately about 35 mg of Amlodipine Besilate RS (separately determine the water <2.48> in the same manner as Amlodipine Besilate), dissolve in methanol to make exactly 50 mL, and use this solution as the amlodipine besilate standard stock solution. Pipet 2 mL of the amlodipine besilate standard stock solution, add 10 mL of methanol, add 0.02 mol/L phosphate buffer solution (pH 3.0) to make exactly 20 mL, and use this solution as the standard solution. Perform the test with exactly 5 μ L each of the sample solution and standard solution as directed under Liquid Chromatography <2.01> according to the following conditions, and determine the peak areas, A_T and A_S , of amlodipine in each solution.

$$\begin{aligned} &\text{Amount (mg) of amlodipine besilate} \\ &(\text{C}_{20}\text{H}_{25}\text{ClN}_2\text{O}_5 \cdot \text{C}_6\text{H}_6\text{O}_3\text{S}) \text{ in 1 tablet} \\ &= M_S \times A_T / A_S \times V' / V \times 1/25 \end{aligned}$$

M_S : Amount (mg) of Amlodipine Besilate RS taken, calculated on the anhydrous basis

Operating conditions—

Proceed as directed in the operating conditions in (1).

System suitability—

System performance: To 10 mL of the irbesartan standard stock solution obtained in (1) and 2 mL of the amlodipine besilate standard stock solution add 0.02 mol/L phosphate buffer solution (pH 3.0) to make 20 mL. When the procedure is run with 5 μ L of this solution under the above operating conditions, amlodipine and irbesartan are eluted in this

order with the resolution between these peaks being not less than 5.

System repeatability: When the test is repeated 6 times with 5 μ L of the standard solution under the above operating conditions, the relative standard deviation of the peak area of amlodipine is not more than 1.0%.

Containers and storage Containers—Tight containers.

Irinotecan Hydrochloride Hydrate

イリノテカン塩酸塩水和物

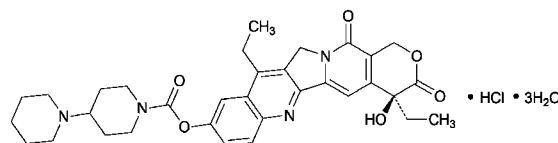

$C_{33}H_{38}N_4O_6 \cdot HCl \cdot 3H_2O$: 677.18

(4*S*)-4,11-Diethyl-4-hydroxy-3,14-dioxo-3,4,12,14-tetrahydro-1*H*-pyrano[3',4':6,7]indolizino[1,2-*b*]quinolin-9-yl [1,4'-bipiperidine]-1'-carboxylate monohydrochloride trihydrate [136572-09-3]

Irinotecan Hydrochloride Hydrate contains not less than 99.0% and not more than 102.0% of irinotecan hydrochloride ($C_{33}H_{38}N_4O_6 \cdot HCl$: 623.14), calculated on the anhydrous basis.

Description Irinotecan Hydrochloride Hydrate occurs as pale yellow to light yellow, crystals or crystalline powder.

It is sparingly soluble in methanol, and slightly soluble in water and in ethanol (99.5).

It is gradually colored to yellow-brown and decomposed by light.

Melting point: about 255°C (with decomposition).

It shows crystal polymorphism.

Identification (1) Determine the absorption spectrum of a solution of Irinotecan Hydrochloride Hydrate in methanol (1 in 100,000) as directed under Ultraviolet-visible Spectrophotometry <2.24>, and compare the spectrum with the Reference Spectrum: both spectra exhibit similar intensities of absorption at the same wavelengths.

(2) Determine the infrared absorption spectrum of Irinotecan Hydrochloride Hydrate as directed in the potassium bromide disk method under Infrared Spectrophotometry <2.25>, and compare the spectrum with the Reference Spectrum: both spectra exhibit similar intensities of absorption at the same wave numbers.

(3) To 1 g of Irinotecan Hydrochloride Hydrate add 50 mL of water, dissolve by heating, and cool: the solution responds to Qualitative Tests <1.09> (2) for chloride.

Optical rotation <2.49> $[\alpha]_D^{20}$: + 64 – + 69° (0.5 g calculated on the anhydrous basis, water, heat, after cooling, 50 mL, 100 mm).

pH <2.54> Dissolve 1 g of Irinotecan Hydrochloride Hydrate in 50 mL of water by heating, and cool: the pH of this solution is between 3.5 and 4.5.

Purity (1) Heavy metals <1.07>—Proceed with 2.0 g of Irinotecan Hydrochloride Hydrate according to Method 2, and perform the test. Prepare the control solution with 2.0 mL of Standard Lead Solution (not more than 10 ppm).

(2) Related substances—Dissolve 50 mg of Irinotecan

Hydrochloride Hydrate in a suitable amount of a mixture of diluted 0.1 mol/L potassium dihydrogen phosphate TS (1 in 10), methanol and acetonitrile (6:4:3) and 1 mL of 1 mol/L hydrochloric acid TS, and add a mixture of diluted 0.1 mol/L potassium dihydrogen phosphate TS (1 in 10), methanol and acetonitrile (6:4:3) to make 20 mL, and use this solution as the sample solution. Pipet 1 mL of the sample solution, add a mixture of diluted 0.1 mol/L potassium dihydrogen phosphate TS (1 in 10), methanol and acetonitrile (6:4:3) to make exactly 100 mL, and use this solution as the standard solution. Perform the test with exactly 20 μ L each of the sample solution and standard solution as directed under Liquid Chromatography <2.01> according to the following conditions. Determine each peak area by the automatic integration method: the peak areas of the related substances A and B, having the relative retention times of about 0.8 to irinotecan, and related substances C and D, having the relative retention times of about 1.6, obtained from the sample solution are not larger than 1/5 times the peak area of irinotecan from the standard solution, and the area of the peak other than irinotecan and the peaks mentioned above from the sample solution is not larger than 1/10 times the peak area of irinotecan from the standard solution. Furthermore, the total area of the peaks other than irinotecan from the sample solution is not larger than 4/5 times the peak area of irinotecan from the standard solution.

Operating conditions—

Detector: An ultraviolet absorption photometer (wavelength: 254 nm).

Column: A stainless steel column 4.6 mm in inside diameter and 25 cm in length, packed with octadecylsilanized silica gel for liquid chromatography (5 μ m in particle diameter).

Column temperature: A constant temperature of about 40°C.

Mobile phase: Dissolve 1.22 g of sodium 1-decanesulfonate in a mixture of diluted 0.1 mol/L potassium dihydrogen phosphate TS (1 in 10), methanol and acetonitrile (6:4:3) to make 1000 mL.

Flow rate: Adjust so that the retention time of irinotecan is about 12 minutes.

Time span of measurement: About 3 times as long as the retention time of irinotecan.

System suitability—

Test for required detectability: Pipet 1 mL of the standard solution, and add a mixture of diluted 0.1 mol/L potassium dihydrogen phosphate TS (1 in 10), methanol and acetonitrile (6:4:3) to make exactly 20 mL. Confirm that the peak area of irinotecan obtained with 20 μ L of this solution is equivalent to 3.5 to 6.5% of that with 20 μ L of the standard solution.

System performance: When the procedure is run with 20 μ L of the standard solution under the above operating conditions, the number of theoretical plates and the symmetry factor of the peak of irinotecan are not less than 6000 and not more than 2.0, respectively.

System repeatability: When the test is repeated 6 times with 20 μ L of the standard solution under the above operating conditions, the relative standard deviation of the peak area of irinotecan is not more than 2.0%.

(3) Enantiomer—Being specified separately when the drug is granted approval based on the Law.

Water <2.48> 7.5 – 9.5% (0.1 g, volumetric titration, direct titration).

Residue on ignition <2.44> Not more than 0.1% (1 g).

Assay Weigh accurately about 0.44 g of Irinotecan Hydro-

chloride Hydrate, dissolve in 120 mL of a mixture of acetic anhydride and acetic acid (100) (7:3), and titrate <2.50> with 0.1 mol/L perchloric acid VS (potentiometric titration). Perform a blank determination in the same manner, and make any necessary correction.

Each mL of 0.1 mol/L perchloric acid VS
= 31.16 mg of C₃₃H₃₈N₄O₆·HCl

Containers and storage Containers—Tight containers.

Storage—Light-resistant.

Others

Related substance A:

(4*S*)-4,11-Diethyl-4,12-dihydroxy-3,14-dioxo-3,4,12,14-tetrahydro-1*H*-pyrano[3',4':6,7]indolizino[1,2-*b*]quinolin-9-yl [1,4'-bipiperidine]-1'-carboxylate

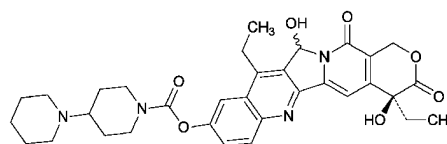

Related substance B:

(4*S*)-4,11-Diethyl-4-hydroxy-3,14-dioxo-3,4,12,14-tetrahydro-1*H*-pyrano[3',4':6,7]indolizino[1,2-*b*]quinolin-9-yl 2'-hydroxy-[1,4'-bipiperidine]-1'-carboxylate

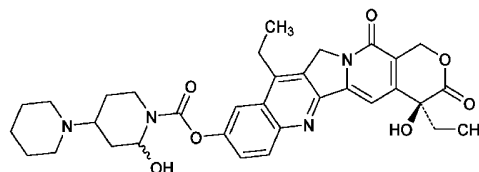

Related substance C:

(4*S*)-4,8,11-Triethyl-4-hydroxy-3,14-dioxo-3,4,12,14-tetrahydro-1*H*-pyrano[3',4':6,7]indolizino[1,2-*b*]quinolin-9-yl [1,4'-bipiperidine]-1'-carboxylate

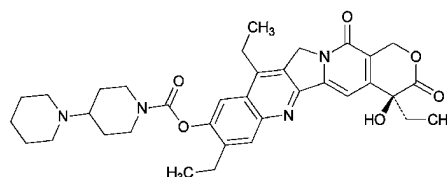

Related substance D:

(4*S*)-4,11-Diethyl-4-hydroxy-3,14-dioxo-3,4,12,14-tetrahydro-1*H*-pyrano[3',4':6,7]indolizino[1,2-*b*]quinolin-9-yl 2'-ethoxy-[1,4'-bipiperidine]-1'-carboxylate

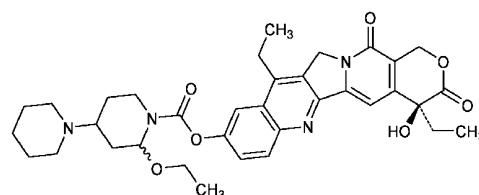

Irinotecan Hydrochloride Injection

イリノテカン塩酸塩注射液

Irinotecan Hydrochloride Injection is an aqueous injection.

It contains not less than 95.0% and not more than 105.0% of the labeled amount of irinotecan hydrochloride hydrate ($C_{33}H_{38}N_4O_6 \cdot HCl \cdot 3H_2O$: 677.18).

Method of preparation Prepare as directed under Injections, with Irinotecan Hydrochloride Hydrate.

Description Irinotecan Hydrochloride Injection is a clear and pale yellow liquid.

It is gradually decomposed by light.

Identification To a volume of Irinotecan Hydrochloride Injection, equivalent to 20 mg of Irinotecan Hydrochloride Hydrate, add water to make 10 mL. To 1 mL of this solution add water to make 100 mL. Determine the absorption spectrum of this solution as directed under Ultraviolet-visible Spectrophotometry <2.24>: it exhibits maxima between 253 nm and 257 nm, between 354 nm and 358 nm, and between 368 nm and 372 nm.

pH Being specified separately when the drug is granted approval based on the Law.

Purity Related substances—To a volume of Irinotecan Hydrochloride Injection, equivalent to 40 mg of Irinotecan Hydrochloride Hydrate, add a mixture of diluted 0.1 mol/L potassium dihydrogen phosphate TS (1 in 10), methanol and acetonitrile (6:4:3) and 1 mL of 1 mol/L hydrochloric acid TS to make 20 mL, and use this solution as the sample solution. Pipet 1 mL of this solution, add a mixture of diluted 0.1 mol/L potassium dihydrogen phosphate TS (1 in 10), methanol and acetonitrile (6:4:3) to make exactly 100 mL, and use this solution as the standard solution. Perform the test with exactly 25 μ L each of the sample solution and standard solution as directed under Liquid Chromatography <2.01> according to the following conditions. Determine each peak area by the automatic integration method: the area of related substance IA, having the relative retention time of about 0.3 to irinotecan, obtained from the sample solution is not larger than 1/2 times the peak area of irinotecan from the standard solution, the areas of related substances A and B, having the relative retention time of about 0.8, from the sample solution are not larger than 3/10 times the peak area of irinotecan from the standard solution, the area of related substance IB, having the relative retention time of about 1.3, from the sample solution is not larger than 1/3 times the peak area of irinotecan from the standard solution, the areas of related substances C and D, having the relative retention time of about 1.6, and the related substance IC, having the relative retention time of about 2.2, from the sample solution are not larger than 1/5 times the peak area of irinotecan from the standard solution, and the area of the peak other than irinotecan and the peaks mentioned above from the sample solution is not larger than 1/10 times the peak area of irinotecan from the standard solution. Furthermore, the total area of the peaks other than irinotecan from the sample solution is not larger than 1.5 times the peak area of irinotecan from the standard solution.

Operating conditions—

Proceed as directed in the operating conditions in the Purity (2) under Irinotecan Hydrochloride Hydrate.

System suitability—

Test for required detectability: Pipet 1 mL of the standard solution, add a mixture of diluted 0.1 mol/L potassium dihydrogen phosphate TS (1 in 10), methanol and acetonitrile (6:4:3) to make exactly 20 mL. Confirm that the peak area of irinotecan obtained with 25 μ L of this solution is equivalent to 3.5 to 6.5% of that with 25 μ L of the standard solution.

System performance: When the procedure is run with 25 μ L of the standard solution under the above operating conditions, the number of theoretical plates and the symmetry factor of the peak of irinotecan are not less than 6000 and not more than 2.0, respectively.

System repeatability: When the test is repeated 6 times with 25 μ L of the standard solution under the above operating conditions, the relative standard deviation of the peak area of irinotecan is not more than 2.0%.

Bacterial endotoxins <4.01> Less than 1.8 EU/mg.

Extractable volume <6.05> It meets the requirement.

Foreign insoluble matter <6.06> Perform the test according to Method 1: it meets the requirement.

Insoluble particulate matter <6.07> It meets the requirement.

Sterility <4.06> Perform the test according to the Membrane filtration method: it meets the requirement.

Assay Pipet a volume of Irinotecan Hydrochloride Injection, equivalent to about 20 mg of irinotecan hydrochloride hydrate ($C_{33}H_{38}N_4O_6 \cdot HCl \cdot 3H_2O$), and add a mixture of methanol and acetic acid-sodium acetate buffer solution (pH 4.0) (11:9) to make exactly 50 mL. Pipet 10 mL of this solution, add the internal standard solution to make exactly 100 mL, and use this solution as the sample solution. Separately, weigh accurately about 20 mg of irinotecan hydrochloride hydrate for assay (separately determine the water <2.48> in the same manner as Irinotecan Hydrochloride Hydrate), dissolve in a mixture of methanol and acetic acid-sodium acetate buffer solution (pH 4.0) (11:9) to make exactly 50 mL. Pipet 10 mL of this solution, add the internal standard solution to make exactly 100 mL, and use this solution as the standard solution. Perform the test with 10 μ L each of the sample solution and standard solution as directed under Liquid Chromatography <2.01> according to the following conditions, and calculate the ratios, Q_T and Q_S , of the peak area of irinotecan to that of the internal standard.

$$\begin{aligned} & \text{Amount (mg) of irinotecan hydrochloride hydrate} \\ & (C_{33}H_{38}N_4O_6 \cdot HCl \cdot 3H_2O) \\ & = M_S \times Q_T / Q_S \times 1.087 \end{aligned}$$

M_S : Amount (mg) of irinotecan hydrochloride hydrate for assay taken, calculated on the anhydrous basis

Internal standard solution—Dissolve 33.3 mg of propyl parahydroxybenzoate in a mixture of methanol and acetic acid-sodium acetate buffer solution (pH 4.0) (11:9) to make 1000 mL.

Operating conditions—

Detector: An ultraviolet absorption photometer (wavelength: 254 nm).

Column: A stainless steel column 6 mm in inside diameter and 15 cm in length, packed with octadecylsilanized silica gel for liquid chromatography (5 μ m in particle diameter).

Column temperature: A constant temperature of about 40°C.

Mobile phase: Dissolve 1.01 g of sodium 1-heptanesul-

fonate in a mixture of methanol and acetic acid-sodium acetate buffer solution (pH 4.0) (11:9) to make 1000 mL.

Flow rate: Adjust so that the retention time of irinotecan is about 7 minutes.

System Suitability—

System performance: When the procedure is run with 10 μ L of the standard solution under the above operating conditions, irinotecan and the internal standard are eluted in this order with the resolution between these peaks being not less than 6.

System repeatability: When the test is repeated 6 times with 10 μ L of the standard solution under the above operating conditions, the relative standard deviation of the ratios of the peak area of irinotecan to that of the internal standard is not more than 1.0%.

Containers and storage Containers—Hermetic containers.

Storage—Light-resistant.

Others

Related substances A, B, C and D: refer to them described in Irinotecan Hydrochloride Hydrate.

Related substances IA:

6-[[1,4'-Bipiperidine]-1'-carboxyloxy]-4-ethyl-2-[(4S)-4-ethyl-4-hydroxy-3,8-dioxo-3,4,7,8-tetrahydro-1H-pyranol[3,4-c]pyridin-6-yl]quinoline-3-carboxylic acid

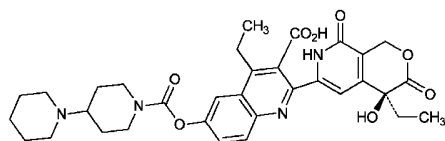

Related substances IB:

3,10-Diethyl-1,13-dioxo-1,3,11,13-tetrahydrofuro[3',4':6,7]indolizino[1,2-b]quinolin-8-yl [1,4'-bipiperidine]-1'-carboxylate

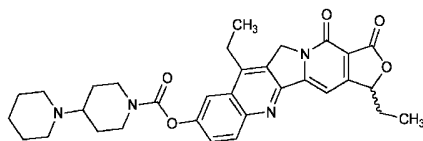

Related substances IC:

12-Ethyl-8-methyl-9-oxo-7-propionyl-9,11-dihydroindolizino[1,2-b]quinolin-2-yl[1,4'-bipiperidine]-1'-carboxylate

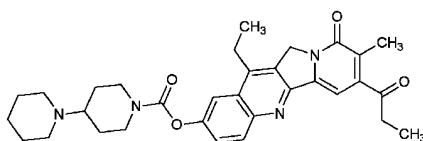

Irsogladine Maleate

イルソグラジンマレイン酸塩

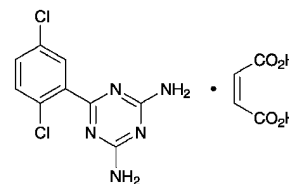

$C_9H_7Cl_2N_5 \cdot C_4H_4O_4$: 372.16

6-(2,5-Dichlorophenyl)-1,3,5-triazine-2,4-diamine monomaleate

[84504-69-8]

Irsogladine Maleate, when dried, contains not less than 99.0% and not more than 101.0% of irsogladine maleate ($C_9H_7Cl_2N_5 \cdot C_4H_4O_4$).

Description Irsogladine Maleate occurs as white, crystals or crystalline powder. It has a slightly bitter taste.

It is sparingly soluble in acetic acid (100) and in ethylene glycol, slightly soluble in methanol and in ethanol (99.5), and practically insoluble in water.

Identification (1) Dissolve 20 mg of Irsogladine Maleate in methanol to make 20 mL. Take 2 mL of this solution, and add water to make 20 mL. To 2 mL of this solution add water to make 50 mL. Determine the absorption spectrum of this solution as directed under Ultraviolet-visible Spectrophotometry <2.24>, and compare the spectrum with the Reference Spectrum: both spectra exhibit similar intensities of absorption at the same wavelengths.

(2) Determine the infrared absorption spectrum of Irsogladine Maleate as directed in the potassium bromide disk method under Infrared Spectrophotometry <2.25>, and compare the spectrum with the Reference Spectrum: both spectra exhibit similar intensities of absorption at the same wave numbers.

(3) Dissolve 10 mg of Irsogladine Maleate in 1 mL of dilute hydrochloric acid and 4 mL of water, and add 3 drops of potassium permanganate TS: the color of the solution is discharged immediately.

Purity (1) Heavy metals <1.07>—Proceed with 2.0 g of Irsogladine Maleate according to Method 4, and perform the test. Prepare the control solution with 2.0 mL of Standard Lead Solution (not more than 10 ppm).

(2) Related substances—Dissolve 50 mg of Irsogladine Maleate in 10 mL of ethylene glycol, and use this solution as the sample solution. Pipet 1 mL of the sample solution, add ethylene glycol to make exactly 100 mL, and use this solution as the standard solution. Perform the test with exactly 5 μ L each of the sample solution and standard solution as directed under Liquid Chromatography <2.01> according to the following conditions. Determine each peak area of both solutions by the automatic integration method: the area of each peak other than the peaks of maleic acid and irsogladine obtained from the sample solution is not larger than 1/10 times the peak area of irsogladine from the standard solution.

Operating conditions—

Detector: An ultraviolet absorption photometer (wavelength: 250 nm).

Column: A stainless steel column 4.6 mm in inside diameter and 7.5 cm in length, packed with octadecylsilanized silica gel for liquid chromatography (3 μ m in particle diame-

ter).

Column temperature: A constant temperature of about 40°C.

Mobile phase: A mixture of methanesulfonic acid solution (1 in 1000) and methanol (4:1).

Flow rate: Adjust so that the retention time of irsogladine is about 8 minutes.

Time span of measurement: About 3 times as long as the retention time of irsogladine, beginning after the solvent peak.

System suitability—

Test for required detectability: Pipet 1 mL of the standard solution, and add ethylene glycol to make exactly 10 mL. Confirm that the peak area of irsogladine obtained with 5 μ L of this solution is equivalent to 7 to 13% of that with 5 μ L of the standard solution.

System performance: When the procedure is run with 5 μ L of the standard solution under the above operating conditions, the number of theoretical plates and the symmetry factor of the peak of irsogladine are not less than 3000 and not more than 1.5, respectively.

System repeatability: When the test is repeated 6 times with 5 μ L of the standard solution under the above operating conditions, the relative standard deviation of the peak area of irsogladine is not more than 2.0%.

Loss on drying <2.41> Not more than 0.5% (1 g, 105°C, 4 hours).

Residue on ignition <2.44> Not more than 0.1% (1 g).

Assay Weigh accurately about 0.3 g of Irsogladine Maleate, previously dried, dissolve in 25 mL of acetic acid (100), add 25 mL of acetic anhydride, and titrate <2.50> with 0.05 mol/L perchloric acid VS (potentiometric titration). Perform a blank determination in the same manner, and make any necessary correction.

Each mL of 0.05 mol/L perchloric acid VS
= 18.61 mg of C₉H₇Cl₂N₅.C₄H₄O₄

Containers and storage Containers—Well-closed containers.

Irsogladine Maleate Fine Granules

イルソグラジンマレイン酸塩細粒

Irsogladine Maleate Fine Granules contain not less than 93.0% and not more than 107.0% of the labeled amount of irsogladine maleate (C₉H₇Cl₂N₅.C₄H₄O₄; 372.16).

Method of preparation Prepare as directed under Granules, with Irsogladine Maleate.

Identification To a quantity of powdered Irsogladine Maleate Fine Granules, equivalent to 2 mg of Irsogladine Maleate, add 5 mL of methanol, shake for 10 minutes, centrifuge, and use the supernatant liquid as the sample solution. Separately, dissolve 2 mg of irsogladine maleate in 5 mL of methanol, and use this solution as the standard solution. Perform the test with these solutions as directed under Thin-layer Chromatography <2.03>. Spot 10 μ L each of the sample solution and standard solution on a plate of silica gel with fluorescent indicator for thin-layer chromatography. Develop the plate with a mixture of petroleum ether, acetone and acetic acid (100) (12:4:1) to a distance of about 10 cm, and air-dry the plate. Examine under ultraviolet light (main wave-

length: 254 nm): the spot from the sample solution has the same R_f value as the spot from the standard solution.

Uniformity of dosage units <6.02> Perform the test according to the following method: Irsogladine Maleate Fine Granules in single-dose packages meet the requirement of the Content uniformity test.

Take out the total contents of 1 package of Irsogladine Maleate Fine Granules, add 2 mL of water, add 2 mL methanol per mg of irsogladine maleate (C₉H₇Cl₂N₅.C₄H₄O₄), sonicate for 10 minutes with occasional shaking, and add water to make exactly V mL so that each mL contains about 40 μ g of irsogladine maleate (C₉H₇Cl₂N₅.C₄H₄O₄). Centrifuge this solution, pipet 1 mL of the supernatant liquid, and add water to make exactly 20 mL. Filter this solution through a membrane filter with a pore size not exceeding 0.5 μ m, discard the first 10 mL of the filtrate, and use the subsequent filtrate as the sample solution. Separately, weigh accurately about 20 mg of irsogladine maleate for assay, previously dried at 105°C for 4 hours, dissolve in methanol to make exactly 20 mL. Pipet 2 mL of this solution, add water to make exactly 100 mL, and use this solution as the standard solution. Perform the test with the sample solution and standard solution as directed under Ultraviolet-visible Spectrophotometry <2.24>, using water as the blank, and determine the absorbances, A_T and A_S, at 210 nm.

Amount (mg) of irsogladine maleate (C₉H₇Cl₂N₅.C₄H₄O₄)
= M_S × A_T/A_S × V/500

M_S: Amount (mg) of irsogladine maleate for assay taken

Dissolution <6.10> When the test is performed at 50 revolutions per minute according to the Paddle method, using 900 mL of water as the dissolution medium, the dissolution rate in 30 minutes of Irsogladine Maleate Fine Granules is not less than 70%.

Start the test with an accurately weighed amount of Irsogladine Maleate Fine Granules, equivalent to about 4 mg of irsogladine maleate (C₉H₇Cl₂N₅.C₄H₄O₄), withdraw not less than 20 mL of the medium at the specified minute after starting the test, and filter through a membrane filter with a pore size not exceeding 0.5 μ m. Discard not less than 10 mL of the first filtrate, and use the subsequent filtrate as the sample solution. Separately, weigh accurately about 40 mg of irsogladine maleate for assay, previously dried at 105°C for 4 hours, and dissolve in methanol to make exactly 20 mL. Pipet 2 mL of this solution, and add water to make exactly 20 mL. Pipet 2 mL of this solution, add water to make exactly 100 mL, and use this solution as the standard solution. Perform the test with the sample solution and standard solution as directed under Ultraviolet-visible Spectrophotometry <2.24>, using water as the blank, and determine the absorbances, A_T and A_S, at 210 nm.

Dissolution rate (%) with respect to the labeled amount of irsogladine maleate (C₉H₇Cl₂N₅.C₄H₄O₄)
= M_S/M_T × A_T/A_S × 1/C × 9

M_S: Amount (mg) of irsogladine maleate for assay taken

M_T: Amount (g) of Irsogladine Maleate Fine Granules taken

C: Labeled amount (mg) of irsogladine maleate (C₉H₇Cl₂N₅.C₄H₄O₄) in 1 g

Assay Weigh accurately an amount of powdered Irsogladine Maleate Fine Granules, equivalent to about 5 mg of irsogladine maleate (C₉H₇Cl₂N₅.C₄H₄O₄), add exactly 5 mL of the internal standard solution, shake until it is dispersed,

and add 5 mL of water. To the solution add 25 mL of ethylene glycol, sonicate for 10 minutes with occasional shaking, and add ethylene glycol to make 50 mL. Filter this solution through a membrane filter with a pore size not exceeding 0.5 μm , discard the first 10 mL of the filtrate, and use the subsequent filtrate as the sample solution. Separately, weigh accurately about 25 mg of irsogladine maleate for assay, previously dried at 105°C for 4 hours, and dissolve in ethylene glycol to make exactly 25 mL. Pipet 5 mL of this solution, add exactly 5 mL of the internal standard solution, add 5 mL of water and ethylene glycol to make 50 mL, and use this solution as the standard solution. Perform the test with 5 μL each of the sample solution and standard solution as directed under Liquid Chromatography <2.01> according to the following conditions, and calculate the ratios, Q_T and Q_S , of the peak area of irsogladine to that of the internal standard.

$$\begin{aligned} \text{Amount (mg) of irsogladine maleate (C}_9\text{H}_7\text{Cl}_2\text{N}_5\text{.C}_4\text{H}_4\text{O}_4) \\ = M_S \times Q_T/Q_S \times 1/5 \end{aligned}$$

M_S : Amount (mg) of irsogladine maleate for assay taken

Internal standard solution—A solution of ethyl parahydroxybenzoate in methanol (1 in 2500).

Operating conditions—

Detector: An ultraviolet absorption photometer (wavelength: 250 nm).

Column: A stainless steel column 4.6 mm in inside diameter and 15 cm in length, packed with octadecylsilanized silica gel for liquid chromatography (5 μm in particle diameter).

Column temperature: A constant temperature of about 25°C.

Mobile phase: A mixture of water, acetonitrile and acetic acid (100) (750:250:3).

Flow rate: Adjust so that the retention time of irsogladine is about 9 minutes.

System suitability—

System performance: When the procedure is run with 5 μL of the standard solution under the above operating conditions, irsogladine and the internal standard are eluted in this order with the resolution between these peaks being not less than 10.

System repeatability: When the test is repeated 6 times with 5 μL of the standard solution under the above operating conditions, the relative standard deviation of the ratio of the peak area of irsogladine to that of the internal standard is not more than 1.0%.

Containers and storage Containers—Tight containers.

Irsogladine Maleate Tablets

イルソグラジンマレイン酸塩錠

Irsogladine Maleate Tablets contain not less than 93.0% and not more than 107.0% of the labeled amount of irsogladine maleate (C₉H₇Cl₂N₅.C₄H₄O₄: 372.16).

Method of preparation Prepare as directed under Tablets, with Irsogladine Maleate.

Identification To a quantity of powdered Irsogladine Maleate Tablets, equivalent 2 mg of Irsogladine Maleate, add 5 mL of methanol, shake for 10 minutes, centrifuge, and use the supernatant liquid as the sample solution. Separately, dissolve 2 mg of irsogladine maleate in 5 mL of methanol, and use this solution as the standard solution. Perform the

test with these solutions as directed under Thin-layer Chromatography <2.03>. Spot 10 μL each of the sample solution and standard solution on a plate of silica gel with fluorescent indicator for thin-layer chromatography. Develop the plate with a mixture of petroleum ether, acetone and acetic acid (100) (12:4:1) to a distance of about 10 cm, and air-dry the plate. Examine under ultraviolet light (main wavelength: 254 nm): the spot from the sample solution has the same R_f value as the spot from the standard solution.

Uniformity of dosage units <6.02> Perform the test according to the following method: it meets the requirement of the Content uniformity test.

To 1 tablet of Irsogladine Maleate Tablets add 2 mL of water, add 2 mL of methanol per mg of irsogladine maleate (C₉H₇Cl₂N₅.C₄H₄O₄), sonicate for 10 minutes with occasional shaking, add water to make exactly V mL so that each mL contains about 40 μg of irsogladine maleate (C₉H₇Cl₂N₅.C₄H₄O₄). Centrifuge this solution, pipet 1 mL of the supernatant liquid, and add water to make exactly 20 mL. Filter this solution through a membrane filter with a pore size not exceeding 0.5 μm , discard the first 10 mL of the filtrate, and use the subsequent filtrate as the sample solution. Separately, weigh accurately about 20 mg of irsogladine maleate for assay, previously dried at 105°C for 4 hours, and dissolve in methanol to make exactly 20 mL. Pipet 2 mL of this solution, and add water to make exactly 20 mL. Pipet 2 mL of this solution, add water to make exactly 100 mL, and use this solution as the standard solution. Perform the test with the sample solution and standard solution as directed under Ultraviolet-visible Spectrophotometry <2.24>, using water as the blank, and determine the absorbances, A_T and A_S , at 210 nm.

$$\begin{aligned} \text{Amount (mg) of irsogladine maleate (C}_9\text{H}_7\text{Cl}_2\text{N}_5\text{.C}_4\text{H}_4\text{O}_4) \\ = M_S \times A_T/A_S \times V/500 \end{aligned}$$

M_S : Amount (mg) of irsogladine maleate for assay taken

Dissolution <6.10> When the test is performed at 50 revolutions per minute according to the Paddle method, using 900 mL of water as the dissolution medium, the dissolution rate in 30 minutes of Irsogladine Maleate Tablets is not less than 80%.

Start the test with 1 tablet of Irsogladine Maleate Tablets, withdraw not less than 20 mL of the medium at the specified minute after starting the test, and filter through a membrane filter with a pore size not exceeding 0.5 μm . Discard not less than 10 mL of the first filtrate, pipet V mL of the subsequent filtrate, add water to make exactly V' mL so that each mL contains about 2.2 μg of irsogladine maleate (C₉H₇Cl₂N₅.C₄H₄O₄), and use this solution as the sample solution. Separately, weigh accurately about 20 mg of irsogladine maleate for assay, previously dried at 105°C for 4 hours, and dissolve in methanol to make exactly 20 mL. Pipet 2 mL of this solution, and add water to make exactly 20 mL. Pipet 2 mL of this solution, add water to make exactly 100 mL, and use this solution as the standard solution. Perform the test with the sample solution and standard solution as directed under Ultraviolet-visible Spectrophotometry <2.24>, using water as the blank, and determine the absorbances, A_T and A_S , at 210 nm.

$$\begin{aligned} \text{Dissolution rate (\%)} \text{ with respect to the labeled amount} \\ \text{of irsogladine maleate (C}_9\text{H}_7\text{Cl}_2\text{N}_5\text{.C}_4\text{H}_4\text{O}_4) \\ = M_S \times A_T/A_S \times V'/V \times 1/C \times 9 \end{aligned}$$

M_S : Amount (mg) of irsogladine maleate for assay taken
 C : Labeled amount (mg) of irsogladine maleate (C₉H₇Cl₂N₅.C₄H₄O₄) in 1 tablet

Assay Weigh accurately the mass of not less than 20 Irsogladine Maleate Tablets, and powder. Weigh accurately a portion of the powder, equivalent to about 5 mg of irsogladine maleate ($C_9H_7Cl_2N_5 \cdot C_4H_4O_4$), add exactly 5 mL of the internal standard solution, shake until it is dispersed, and add 5 mL of water. To this solution add 25 mL of ethylene glycol, sonicate for 10 minutes with occasional shaking, and add ethylene glycol to make 50 mL. Filter this solution through a membrane filter with a pore size not exceeding 0.5 μ m, discard the first 10 mL of the filtrate, and use the subsequent filtrate as the sample solution. Separately, weigh accurately about 25 mg of irsogladine maleate for assay, previously dried at 105°C for 4 hours, and dissolve in ethylene glycol to make exactly 25 mL. Pipet 5 mL of this solution, add exactly 5 mL of the internal standard solution, add 5 mL of water and ethylene glycol to make 50 mL, and use this solution as the standard solution. Perform the test with 5 μ L each of the sample solution and standard solution as directed under Liquid Chromatography <2.01> according to the following conditions, and calculate the ratios, Q_T and Q_S , of the peak area of irsogladine to that of the internal standard.

$$\text{Amount (mg) of irsogladine maleate (C}_9\text{H}_7\text{Cl}_2\text{N}_5 \cdot \text{C}_4\text{H}_4\text{O}_4) \\ = M_S \times Q_T / Q_S \times 1/5$$

M_S : Amount (mg) of irsogladine maleate for assay taken

Internal standard solution—A solution of ethyl parahydroxybenzoate in methanol (1 in 2500).

Operating conditions—

Detector: An ultraviolet absorption photometer (wavelength: 250 nm).

Column: A stainless steel column 4.6 mm in inside diameter and 15 cm in length, packed with octadecylsilanized silica gel for liquid chromatography (5 μ m in particle diameter).

Column temperature: A constant temperature of about 25°C.

Mobile phase: A mixture of water, acetonitrile and acetic acid (100) (750:250:3).

Flow rate: Adjust so that the retention time of irsogladine is about 9 minutes.

System suitability—

System performance: When the procedure is run with 5 μ L of the standard solution under the above operating conditions, irsogladine and the internal standard are eluted in this order with the resolution between these peaks being not less than 10.

System repeatability: When the test is repeated 6 times with 5 μ L of the standard solution under the above operating conditions, the relative standard deviation of the ratio of the peak area of irsogladine to that of the internal standard is not more than 1.0%.

Containers and storage Containers—Tight containers.

Isepamicin Sulfate

イセパマイシン硫酸塩

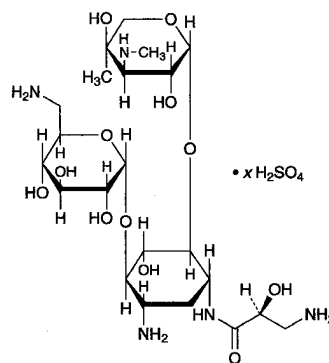

$C_{22}H_{43}N_5O_{12} \cdot xH_2SO_4$

6-Amino-6-deoxy- α -D-glucopyranosyl-(1 \rightarrow 4)-[3-deoxy-4-C-methyl-3-methylamino- β -L-arabinopyranosyl-(1 \rightarrow 6)]-2-deoxy-1-N-[(2S)-3-amino-2-hydroxypropanoyl]-D-streptamine sulfate [67814-76-0]

Isepamicin Sulfate is the sulfate of a derivative of gentamycin B, an aminoglycoside substance, having antibacterial activity produced by the growth of *Micromonospora purpurea*.

It contains not less than 680 μ g (potency) and not more than 780 μ g (potency) per mg, calculated on the anhydrous basis. The potency of Isepamicin Sulfate is expressed as mass (potency) of isepamicin ($C_{22}H_{43}N_5O_{12}$: 569.60).

Description Isepamicin Sulfate occurs as a white to pale yellow-white powder.

It is very soluble in water, and practically insoluble in methanol and in ethanol (95).

It is hygroscopic.

Identification (1) Dissolve 20 mg of Isepamicin Sulfate in 1 mL of water, add 3 mL of anthrone TS, shake, and allow to stand: a blue-purple color develops.

(2) Dissolve 10 mg each of Isepamicin Sulfate and Isepamicin Sulfate RS in 5 mL of water, and use these solutions as the sample solution and standard solution. Perform the test with these solutions as directed under Thin-layer chromatography <2.03>. Spot 5 μ L each of the sample solution and standard solution on a plate of silica gel for thin-layer chromatography. Develop the plate with a mixture of ammonia water (28), ethanol (99.5), 1-butanol and chloroform (5:5:4:2) to a distance of about 15 cm, and air-dry the plate. Spray evenly 0.2% ninhydrin-water saturated 1-butanol TS on the plate, and heat the plate at about 100°C for about 10 minutes: the principal spots from the sample solution and the spot from the standard solution exhibit a red-brown color and show the same R_f value.

(3) Dissolve 10 mg of Isepamicin Sulfate in 1 mL of water, and add 1 drop of barium chloride TS: a white precipitate is produced.

Optical rotation <2.49> $[\alpha]_D^{20}$: +100 – +120° (0.25 g calculated on the anhydrous bases, water, 25 mL, 100 mm).

pH <2.54> Dissolve 0.5 g of Isepamicin Sulfate in 5 mL of water: the pH of the solution is between 5.5 and 7.5.

Purity (1) Clarity and color of solution—Dissolve 1.0 g

of Isepamicin Sulfate in 10 mL of water: the solution is clear and colorless.

(2) Heavy metals <1.07>—Proceed with 1.0 g of Isepamicin Sulfate according to Method 4, and perform the test. Prepare the control solution with 1.0 mL Standard Lead Solution (not more than 10 ppm).

(3) Related substances—Use the sample solution obtained in the Assay as the sample solution. Perform the test with 5 μ L of the sample solution as directed under Liquid Chromatography <2.01> according to the following conditions. Determine each peak area of the sample solution by the automatic integration method, and calculate the amounts of their peaks by the area percentage method: the amount of HAPA-gentamine-B equivalent to about 0.4 of the relative retention time to isepamicin is not more than 5.0%, and gentamicin B equivalent to about 1.3 of that is not more than 3.0%. For the peak area of gentamicin B, multiply the correction factor, 1.11.

Operating conditions—

Apparatus, detector, column, column temperature, reaction coil, mobile phase, reagent, reaction temperature, flow rate of mobile phase, and flow rate of reagent: Proceed as directed in the operating conditions in the Assay.

Time span of measurement: About 2 times as long as the retention time of isepamicin.

System suitability—

System performance and system repeatability: Proceed as directed in the system suitability in the Assay.

Test for required detectability: To 1 mL of the sample solution, add water to make 10 mL, and use this solution as the solution for system suitability test. Pipet 1 mL of the solution for system suitability test, and add water to make exactly 10 mL. Confirm that the peak area of isepamicin obtained with 5 μ L of this solution is equivalent to 7 to 13% of that with 5 μ L of the solution for system suitability test.

Water <2.48> Not more than 12.0% (0.2 g, volumetric titration, direct titration. Use a mixture of formamide for water determination and methanol for water determination (2:1) instead of methanol for water determination).

Residue on ignition <2.44> Not more than 1.0% (1 g).

Assay Weigh accurately an amount of Isepamicin Sulfate and Isepamicin Sulfate RS, equivalent to about 20 mg (potency), dissolve each in water to make exactly 100 mL, and use these solutions as the sample solution and the standard solution, respectively. Perform the test with exactly 5 μ L each of the sample solution and standard solution as directed under Liquid Chromatography <2.01> according to the following conditions, and determine the peak areas, A_T and A_S , of isepamicin in each solution.

$$\begin{aligned} \text{Amount } [\mu\text{g (potency)}] \text{ of isepamicin (C}_{22}\text{H}_{43}\text{N}_5\text{O}_{12}) \\ = M_S \times A_T / A_S \times 1000 \end{aligned}$$

M_S : Amount [mg (potency)] of Isepamicin Sulfate RS taken

Operating conditions—

Apparatus: Consist of two pumps for the mobile phase and the reagent transport, inject port, column, reaction coil, detector and recorder. Use a reaction coil with thermostat.

Detector: A fluorophotometer (excitation wavelength: 360 nm, detection wavelength: 440 nm).

Column: A stainless steel column 4 mm in inside diameter and 15 cm in length, packed with octadecylsilanized silica gel for liquid chromatography (5 μ m in particle diameter).

Column temperature: A constant temperature of about 25°C.

Reaction coil: A column 0.25 mm in inside diameter and 5 m in length.

Mobile phase: Dissolve 28.41 g of anhydrous sodium sulfate and 5.23 g of sodium 1-pentane sulfonate in 900 mL of water, add 1 mL of acetic acid (100), and add water to make exactly 1000 mL.

Reagent: To 500 mL of boric acid-potassium chloride-sodium hydroxide buffer solution (pH 10.0) add 5 mL of a solution of *o*-phthalaldehyde in ethanol (95) (2 in 25), 1 mL of 2-mercaptoethanol and 2 mL of a solution of lauracrogol (1 in 4).

Reaction temperature: A constant temperature of about 45°C.

Flow rate of mobile phase: About 0.6 mL per minute.

Flow rate of reagent: About 0.5 mL per minute.

System suitability—

System performance: Dissolve 2 mg of gentamicin B in 10 mL of the standard solution. When the procedure is run with 5 μ L of this solution under the above operating conditions, isepamicin and gentamicin B are eluted in this order with the resolution between these peaks being not less than 1.0.

System repeatability: When the test is repeated 5 times with 5 μ L of the standard solution under the above operating conditions, the relative standard deviation of the peak areas of isepamicin is not more than 3.0%.

Containers and storage Containers—Tight containers.

Isepamicin Sulfate Injection

イセパマイシン硫酸塩注射液

Isepamicin Sulfate Injection is an aqueous injection.

It contains not less than 90.0% and not more than 110.0% of the labeled potency of isepamicin (C₂₂H₄₃N₅O₁₂: 569.60).

Method of preparation Prepare as directed under Injections, with Isepamicin Sulfate.

Description Isepamicin Sulfate Injection is a clear, colorless liquid.

Identification To a volume of Isepamicin Sulfate Injection, equivalent to 20 mg (potency) of Isepamicin Sulfate, add water to make 10 mL, and use this solution as the sample solution. Separately, dissolve an amount of Isepamicin Sulfate RS, equivalent to 20 mg (potency) in 10 mL of water, and use this solution as the standard solution. Proceed with these solutions as directed in the Identification (2) under Isepamicin Sulfate.

Osmotic pressure ratio Being specified separately when the drug is granted approval based on the Law.

pH <2.54> 5.5 – 7.5.

Purity Related substances—Use the sample solution obtained in the Assay as the sample solution. Perform the test with 5 μ L of the sample solution as directed under Liquid Chromatography <2.01> according to the following conditions. Determine each peak area of the sample solution by the automatic integration method and calculate the amounts of their peaks by the area percentage method: the amount of isoserine, having the relative retention time of about 0.3 to isepamicin, is not more than 2.0%, and the amount of gentamicin B, having the relative retention time of about 1.3, is not more than 4.0%. For the peak area of gentamicin B, multiply the correction factor, 1.11.

Operating conditions—

Apparatus, detector, column, column temperature, reaction coil, mobile phase, reaction reagent, reaction temperature, flow rate of mobile phase, and flow rate of reaction reagent: Proceed as directed in the operating conditions in the Assay under Isepamicin Sulfate.

Time span of measurement: About 2 times as long as the retention time of isepamicin.

System suitability—

System performance and system repeatability: Proceed as directed in the Assay under Isepamicin Sulfate.

Test for required detectability: To 1 mL of the sample solution add water to make 10 mL, and use this solution as the solution for system suitability test. Pipet 1 mL of the solution for system suitability test, and add water to make exactly 10 mL. Confirm that the peak area of isepamicin obtained with 5 μ L of this solution is equivalent to 7 to 13% of that with 5 μ L of the solution for system suitability test.

Bacterial endotoxins <4.01> Less than 0.50 EU/mg (potency).

Extractable volume <6.05> It meets the requirement.

Foreign insoluble matter <6.06> Perform the test according to Method 1: it meets the requirement.

Insoluble particulate matter <6.07> It meets the requirement.

Sterility <4.06> Perform the test according to the Membrane filtration method: it meets the requirement.

Assay Pipet a volume of Isepamicin Sulfate Injection, equivalent to about 0.2 g (potency) of Isepamicin Sulfate, add water to make exactly 100 mL. Pipet 10 mL of this solution, add water to make exactly 100 mL, and use this solution as the sample solution. Separately, weigh accurately an amount of Isepamicin Sulfate RS, equivalent to about 20 mg (potency), dissolve in water to make exactly 100 mL, and use this solution as the standard solution. Proceed as directed in the Assay under Isepamicin Sulfate.

$$\begin{aligned} \text{Amount [mg (potency)] of isepamicin (C}_{22}\text{H}_{43}\text{N}_5\text{O}_{12}) \\ = M_S \times A_T/A_S \times 10 \end{aligned}$$

M_S : Amount [mg (potency)] of Isepamicin Sulfate RS taken

Containers and storage Containers—Hermetic containers.

Shelf life 24 months after preparation.

Isoflurane

イソフルラン

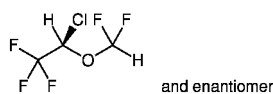

$\text{C}_3\text{H}_2\text{ClF}_5\text{O}$: 184.49

(2*RS*)-2-Chloro-2-(difluoromethoxy)-1,1,1-trifluoroethane
[26675-46-7]

Isoflurane contains not less than 99.0% and not more than 101.0% of isoflurane ($\text{C}_3\text{H}_2\text{ClF}_5\text{O}$), calculated on the anhydrous basis.

Description Isoflurane occurs as a clear, colorless fluid liquid.

It is miscible with ethanol (99.5), with methanol and with *o*-xylene.

It is slightly soluble in water.

It is volatile, and has no inflammability.

It shows no optical rotation.

Refractive index n_D^{20} : about 1.30

Boiling point: about 47 – 50°C

Identification (1) The test solution obtained by Oxygen Flask Combustion Method <1.06> with 50 μ L of Isoflurane, using 40 mL of water as the absorbing liquid, responds to Qualitative Tests <1.09> for chloride and fluoride.

(2) Determine the infrared absorption spectrum of Isoflurane as directed in the liquid film method under Infrared Spectrophotometry <2.25>, and compare the spectrum with the Reference Spectrum or the spectrum of Isoflurane RS: both spectra exhibit similar intensities of absorption at the same wave numbers.

Specific gravity <2.56> d_{20}^{20} : 1.500 – 1.520

Purity (1) Acidity or alkalinity—To 10 mL of Isoflurane add 5 mL of freshly boiled and cooled water, and shake for 1 minute: the water layer is neutral.

(2) Soluble chloride—To 60 g of Isoflurane add 40 mL of water, shake thoroughly, and separate the water layer. To 20 mL of the layer add 6 mL of dilute nitric acid and water to make 50 mL. Perform the test with this solution as directed under Chloride Limit Test <1.03>. Prepare the control solution with 0.25 mL of 0.01 mol/L hydrochloric acid VS (not more than 3 ppm).

(3) Soluble fluoride—To 6 g of Isoflurane add 12 mL of diluted 0.01 mol/L sodium hydroxide TS (1 in 20), and shake for 10 minutes. Transfer 4.0 mL of the water layer into a Nessler tube, add 30 mL of a mixture of alizarin complexone TS, acetic acid-potassium acetate buffer solution (pH 4.3) and cerium (III) nitrate TS (1:1:1), add water to make 50 mL, allow to stand for 60 minutes, and use this solution as the sample solution. Separately, to 0.4 mL of the fluorine standard solution and 4.0 mL of diluted 0.01 mol/L sodium hydroxide TS (1 in 20) in a Nessler tube add 30 mL of the mixture of alizarin complexone TS, acetic acid-potassium acetate buffer solution (pH 4.3) and cerium (III) nitrate TS (1:1:1), then proceed in the same manner as for the preparation of the sample solution, and use the solution so obtained as the standard solution. Determine the absorbances of the sample solution and standard solution at 600 nm as directed under Ultraviolet-visible Spectrophotometry <2.24>, using a solution, obtained by proceeding in the same manner as above with 4.0 mL of diluted 0.01 mol/L sodium hydroxide TS (1 in 20), as the blank: the absorbance of the sample solution is not more than that of the standard solution (not more than 2 ppm).

Fluorine standard solution: Dissolve exactly 2.21 g of sodium fluoride in water to make exactly 1000 mL. Pipet 10 mL of this solution, and add water to make exactly 1000 mL. Each mL of this solution contains 0.01 mg of fluorine (F).

(4) Related substances—Use Isoflurane as the sample solution. To exactly 1 mL of the sample solution add *o*-xylene to make exactly 100 mL. Pipet 1 mL of this solution, add *o*-xylene to make exactly 100 mL, and use this solution as the standard solution. Perform the test with exactly 5 μ L each of the sample solution and standard solution as directed under Gas Chromatography <2.02> according to the following conditions, and determine each peak area by the automatic integration method: the area of the peak other than isoflurane from sample solution is not larger than the peak area of

isoflurane from the standard solution, and the total area of the peaks other than isoflurane from the sample solution is not larger than 3 times the peak area of isoflurane from the standard solution.

Operating conditions—

Detector, column, column temperature, carrier gas, and flow rate: Proceed as directed in the operating conditions in the Assay.

Time span of measurement: About 5 times as long as the retention time of isoflurane.

System suitability—

System performance and system repeatability: Proceed as directed in the system suitability in the Assay.

Test for required detectability: To exactly 1 mL of the standard solution add *o*-xylene to make exactly 2 mL. Confirm that the peak area of isoflurane obtained with 5 μ L of this solution is equivalent to 35 to 65% of that with 5 μ L of the standard solution.

(5) Peroxide—Take 10 mL of Isoflurane in a Nessler tube add 1 mL of a freshly prepared solution of potassium iodide (1 in 10), shake vigorously, and allow to stand in a dark place for 1 hour: the water layer is not yellow.

(6) Residue on evaporation—Pipet 65 mL of Isoflurane, evaporate on a water bath, and dry the residue at 105°C for 1 hour: not more than 1.0 mg.

Water <2.48> Not more than 0.1% (2 g, Coulometric titration).

Assay To exactly 5 mL each of Isoflurane and Isoflurane RS (separately determined the water <2.48> in the same manner as Isoflurane), add exactly 3 mL of ethyl acetate as the internal standard, then add *o*-xylene to make 50 mL each. To 5 mL each of these solutions add *o*-xylene to make 50 mL, and use these solutions as the sample solution and the standard solution, respectively. Perform the test with 2 μ L each of the sample solution and standard solution as directed under Gas Chromatography <2.02> according to the following conditions, and calculate the ratios, Q_T and Q_S , of the peak area of isoflurane to that of the internal standard.

$$\begin{aligned} &\text{Amount (mg) of isoflurane (C}_3\text{H}_2\text{ClF}_5\text{O) in 5 mL of} \\ &\text{Isoflurane} \\ &= V_S \times Q_T / Q_S \times 1000 \times 1.506 \end{aligned}$$

V_S : Amount (mL) of Isoflurane RS taken, calculated on the anhydrous basis

1.506: Specific gravity (d_{20}^{20}) of isoflurane

Operating conditions—

Detector: A hydrogen flame-ionization detector.

Column: A stainless steel column 3 mm in inside diameter and 3.5 m in length, packed with siliceous earth for gas chromatography (125 – 149 μ m in particle diameter), coated in 10% with nonylphenoxypoly(ethyleneoxy)ethanol for gas chromatography and in 15% with polyalkylene glycol for gas chromatography.

Column temperature: A constant temperature of about 80°C.

Carrier gas: Nitrogen.

Flow rate: Adjust so that the retention time of isoflurane is about 7 minutes.

System suitability—

System performance: When the procedure is run with 2 μ L of the standard solution under the above operating conditions, isoflurane and the internal standard are eluted in this order with the resolution between these peaks being not less than 3.

System repeatability: When the test is repeated 6 times

with 2 μ L of the standard solution under the above operating conditions, the relative standard deviation of the peak area of isoflurane is not more than 1.0%.

Containers and storage Containers—Tight containers.

Storage—At a temperature not exceeding 30°C.

L-Isoleucine

L-イソロイシン

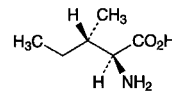

$\text{C}_6\text{H}_{13}\text{NO}_2$: 131.17

(2*S*,3*S*)-2-Amino-3-methylpentanoic acid
[73-32-5]

L-Isoleucine, when dried, contains not less than 98.5% of L-isoleucine ($\text{C}_6\text{H}_{13}\text{NO}_2$).

Description L-Isoleucine occurs as white, crystals or crystalline powder. It is odorless or has a faint characteristic odor, and has a slightly bitter taste.

It is freely soluble in formic acid, sparingly soluble in water, and practically insoluble in ethanol (95).

It dissolves in dilute hydrochloric acid.

Identification Determine the infrared absorption spectrum of L-Isoleucine, previously dried, as directed in the potassium bromide disk method under Infrared Spectrophotometry <2.25>, and compare the spectrum with the Reference Spectrum: both spectra exhibit similar intensities of absorption at the same wave numbers.

Optical rotation <2.49> $[\alpha]_D^{20}$: +39.5 – +41.5° (after drying, 1 g, 6 mol/L hydrochloric acid TS, 25 mL, 100 mm).

pH <2.54> Dissolve 1.0 g of L-Isoleucine in 100 mL of water: the pH of this solution is between 5.5 and 6.5.

Purity (1) Clarity and color of solution—Dissolve 0.5 g of L-Isoleucine in 10 mL of 1 mol/L hydrochloric acid TS: the solution is clear and colorless.

(2) Chloride <1.03>—Perform the test with 0.5 g of L-Isoleucine. Prepare the control solution with 0.30 mL of 0.01 mol/L hydrochloric acid VS (not more than 0.021%).

(3) Sulfate <1.14>—Perform the test with 0.6 g of L-Isoleucine. Prepare the control solution with 0.35 mL of 0.005 mol/L sulfuric acid VS (not more than 0.028%).

(4) Ammonium <1.02>—Perform the test with 0.25 g of L-Isoleucine. Prepare the control solution with 5.0 mL of Standard Ammonium Solution (not more than 0.02%).

(5) Heavy metals <1.07>—Dissolve 1.0 g of L-Isoleucine in 40 mL of water and 2 mL of dilute acetic acid by warming, cool, and add water to make 50 mL. Perform the test using this solution as the test solution. Prepare the control solution as follows: to 2.0 mL of Standard Lead Solution add 2 mL of dilute acetic acid and water to make 50 mL (not more than 20 ppm).

(6) Arsenic <1.11>—Prepare the test solution with 1.0 g of L-Isoleucine according to Method 2, and perform the test (not more than 2 ppm).

(7) Related substances—Dissolve 0.10 g of L-Isoleucine in 25 mL of water, and use this solution as the sample solution. Pipet 1 mL of the sample solution, and add water to make exactly 50 mL. Pipet 5 mL of this solution, add water to make exactly 20 mL, and use this solution as the standard

solution. Perform the test with these solutions as directed under Thin-layer Chromatography <2.03>. Spot 5 μL each of the sample solution and standard solution on a plate of silica gel for thin-layer chromatography. Develop the plate with a mixture of 1-butanol, water and acetic acid (100) (3:1:1) to a distance of about 10 cm, and dry the plate at 80°C for 30 minutes. Spray evenly the plate with a solution of ninhydrin in acetone (1 in 50), and heat the plate at 80°C for 5 minutes: the spots other than the principal spot obtained from the sample solution are not more intense than the spot from the standard solution.

Loss on drying <2.41> Not more than 0.30% (1 g, 105°C, 3 hours).

Residue on ignition <2.44> Not more than 0.1% (1 g).

Assay Weigh accurately about 0.13 g of L-Isoleucine, previously dried, and dissolve in 3 mL of formic acid, add 50 mL of acetic acid (100), and titrate <2.50> with 0.1 mol/L perchloric acid VS (potentiometric titration). Perform a blank determination in the same manner, and make any necessary correction.

$$\begin{aligned} \text{Each mL of 0.1 mol/L perchloric acid VS} \\ = 13.12 \text{ mg of } \text{C}_6\text{H}_{13}\text{NO}_2 \end{aligned}$$

Containers and storage Containers—Tight containers.

L-Isoleucine, L-Leucine and L-Valine Granules

イソロイシン・ロイシン・バリン顆粒

L-Isoleucine, L-Leucine and L-Valine Granules contain not less than 93.0% and not more than 107.0% of the labeled amount of L-isoleucine ($\text{C}_6\text{H}_{13}\text{NO}_2$: 131.17), L-leucine ($\text{C}_6\text{H}_{13}\text{NO}_2$: 131.17) and L-valine ($\text{C}_5\text{H}_{11}\text{NO}_2$: 117.15).

Method of preparation Prepare as directed under Granules, with L-Isoleucine, L-Leucine and L-Valine.

Identification Dissolve an amount of powdered L-Isoleucine, L-Leucine and L-Valine Granules, equivalent to about 92 mg of L-Isoleucine, in the mobile phase to make 100 mL, and use this solution as the sample solution. Separately, dissolve 0.46 g of L-isoleucine, 0.92 g of L-leucine and 0.55 g of L-valine in the mobile phase to make 100 mL. Take 10 mL of this solution, add the mobile phase to make 50 mL, and use this solution as the standard solution. Perform the test with 20 μL each of the sample solution and the standard solution as directed under Liquid Chromatography <2.01> according to the following conditions: the retention times of the peak in the chromatograms obtained from the sample solution and the standard solution are the same.

Operating conditions—

Detector: An ultraviolet absorption photometer (wavelength: 210 nm).

Column: A stainless steel column 4.6 mm in inside diameter and 15 cm in length, packed with octadecylsilanized silica gel for liquid chromatography (3 μm in particle diameter).

Column temperature: A constant temperature of about 40°C.

Mobile phase: Dissolve 31.2 g of sodium dihydrogen phosphate dihydrate in 1000 mL of water, and adjust to pH 2.8 with phosphoric acid. To 970 mL of this solution add 30 mL of acetonitrile.

Flow rate: Adjust so that the retention time of L-valine is about 2.5 minutes.

System suitability—

System performance: When the procedure is run with 20 μL of the standard solution under the above operating conditions, valine, isoleucine and leucine are eluted in this order, and the resolution between the peaks of isoleucine and leucine is not less than 1.5.

System repeatability: When the test is repeated 6 times with 20 μL of the standard solution under the above operating conditions, the relative standard deviations of the retention time of isoleucine, leucine and valine are not more than 1.0%, respectively.

Uniformity of dosage units <6.02> Perform the test according to the following method: the Granules in single-dose package meets the requirement of the Content uniformity test.

To the total content of 1 package of L-Isoleucine, L-Leucine and L-Valine Granules add exactly $V/25$ mL of the internal standard solution, and add 0.1 mol/L hydrochloric acid TS to make V mL so that each mL contains about 3.8 mg of L-isoleucine ($\text{C}_6\text{H}_{13}\text{NO}_2$). To 2 mL of this solution add 0.02 mol/L hydrochloric acid TS to make 200 mL, and use this solution as the sample solution. Then, proceed as directed in the Assay.

$$\begin{aligned} \text{Amount (mg) of L-isoleucine (C}_6\text{H}_{13}\text{NO}_2) \\ = M_{\text{Sa}} \times Q_{\text{Ta}}/Q_{\text{Sa}} \times V/50 \\ \text{Amount (mg) of L-leucine (C}_6\text{H}_{13}\text{NO}_2) \\ = M_{\text{Sb}} \times Q_{\text{Tb}}/Q_{\text{Sb}} \times V/50 \\ \text{Amount (mg) of L-valine (C}_5\text{H}_{11}\text{NO}_2) \\ = M_{\text{Sc}} \times Q_{\text{Tc}}/Q_{\text{Sc}} \times V/50 \end{aligned}$$

M_{Sa} : Amount (mg) of L-isoleucine for assay taken

M_{Sb} : Amount (mg) of L-leucine for assay taken

M_{Sc} : Amount (mg) of L-valine for assay taken

Internal standard solution—A solution of glycine in 0.1 mol/L hydrochloric acid TS (1 in 20).

Disintegration <6.09> It meets the requirement. Carry out the test for 15 minutes.

Assay Powder the total amount of the content of not less than ten packages of L-Isoleucine, L-Leucine and L-Valine Granules. Weigh accurately a portion of the powder, equivalent to about 0.95 g of L-isoleucine ($\text{C}_6\text{H}_{13}\text{NO}_2$), add exactly 10 mL of the internal standard solution, dissolve in 0.1 mol/L hydrochloric acid TS to make 250 mL. To 2 mL of this solution add 0.02 mol/L hydrochloric acid TS to make 200 mL, and use this solution as the sample solution. Separately, weigh accurately about 0.2 g of L-isoleucine for assay, about 0.4 g of L-leucine for assay and about 0.24 g of L-valine for assay, previously these are dried at 105°C for 3 hours, add exactly 2 mL of the internal standard solution, dissolve in 0.1 mol/L hydrochloric acid TS to make 100 mL. To 2 mL of this solution add 0.02 mol/L hydrochloric acid TS to make 100 mL, and use this solution as the standard solution. Perform the test with 20 μL each of the sample solution and standard solution as directed under Liquid Chromatography <2.01> according to the following conditions. Calculate the ratios, Q_{Ta} , Q_{Tb} and Q_{Tc} of the peak area of L-isoleucine, L-leucine and L-valin to that of the internal standard obtained from the sample solution, and the ratios, Q_{Sa} , Q_{Sb} and Q_{Sc} of the peak area of L-isoleucine, L-leucine and L-valin to that of the internal standard from the standard solution.

Amount (mg) of L-isoleucine (C₆H₁₃NO₂)

$$= M_{Sa} \times Q_{Ta} / Q_{Sa} \times 5$$

Amount (mg) of L-leucine (C₆H₁₃NO₂)

$$= M_{Sb} \times Q_{Tb} / Q_{Sb} \times 5$$

Amount (mg) of L-valine (C₅H₁₁NO₂)

$$= M_{Sc} \times Q_{Tc} / Q_{Sc} \times 5$$

M_{Sa} : Amount (mg) of L-isoleucine for assay taken

M_{Sb} : Amount (mg) of L-leucine for assay taken

M_{Sc} : Amount (mg) of L-valine for assay taken

Internal standard solution—A solution of glycine in 0.1 mol/L hydrochloric acid TS (1 in 20).

Operating conditions—

Detector: A visible absorption photometer (wavelength: 570 nm).

Column: A stainless steel column 4.6 mm in inside diameter and 6 cm in length, packed with strongly acidic ion-exchange resin for liquid chromatography composed with a sulfonated polystyrene (3 μm in particle diameter) (sodium type).

Column temperature: A constant temperature of about 57°C.

Reaction vessel temperature: A constant temperature of about 130°C.

Reaction time: About 1 minute.

Mobile phase: After prepare the mobile phases A, B, C, D and E according to the following table, add 0.1 mL caprylic acid to each mobile phase.

	Mobile phase A	Mobile phase B	Mobile phase C	Mobile phase D	Mobile phase E
Citric acid monohydrate	19.80 g	22.00 g	12.80 g	6.10 g	—
Trisodium citrate dihydrate	6.19 g	7.74 g	13.31 g	26.67 g	—
Sodium chloride	5.66 g	7.07 g	3.74 g	54.35 g	—
Sodium hydroxide	—	—	—	—	8.00 g
Ethanol (99.5)	130 mL	20 mL	4 mL	—	100 mL
Thiodiglycol	5 mL	5 mL	5 mL	—	—
Benzyl alcohol	—	—	—	5 mL	—
Lauromacrogol solution (1 in 4)	4 mL	4 mL	4 mL	4 mL	4 mL
Water	a sufficient amount	a sufficient amount	a sufficient amount	a sufficient amount	a sufficient amount
Total amount	1000 mL	1000 mL	1000 mL	1000 mL	1000 mL

Switching of mobile phase: Switch the mobile phases A, B, C, D and E sequentially so that when proceed with 20 μL of the standard solution under the conditions above, the internal standard, valine, isoleucine and leucine are eluted in this order with the resolution between the peaks of isoleucine and leucine being not less than 1.2.

Reaction reagent: Dissolve 407 g of lithium acetate dihydrate in an appropriate amount of water, add 245 mL of acetic acid (100), 801 mL of 1-methoxy-2-propanol and water to make 2000 mL, pass nitrogen for 10 minutes, and use this solution as Solution (I). Separately, to 1957 mL of 1-methoxy-2-propanol add 77 g of ninhydrin, pass nitrogen for 5 minutes, add 0.161 g of sodium borohydride, and pass nitrogen for 30 minutes. To this solution add an equal volume of the Solution (I). Prepare before use.

Flow rate of mobile phase: 0.40 mL per minute.

Flow rate of reaction reagent: 0.35 mL per minute.

System suitability—

System performance: When the test is run with 20 μL of

the standard solution under the above operating conditions, the internal standard, valine, isoleucine and leucine are eluted in this order with the resolution between the peaks of isoleucine and leucine being not less than 1.2.

System repeatability: When the test is repeated 6 times with 20 μL of the standard solution under the above operating conditions, the relative standard deviations of the ratio of the peak area of isoleucine, leucine and valine to that of the internal standard are not more than 1.0%, respectively.

Containers and storage Containers—Tight containers.

Isomalt Hydrate

Isomalt

イソマル水和物

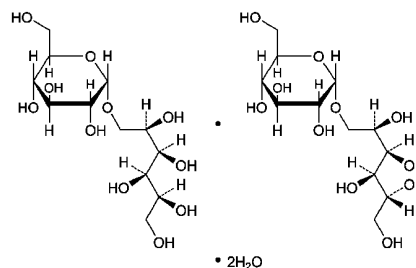

6-*O*-α-D-Glucopyranosyl-D-glucitol C₁₂H₂₄O₁₁: 344.31

1-*O*-α-D-Glucopyranosyl-D-mannitol dihydrate

C₁₂H₂₄O₁₁·2H₂O: 380.34

6-*O*-α-D-Glucopyranosyl-D-glucitol—1-*O*-α-D-glucopyranosyl-D-mannitol dihydrate
[64519-82-0]

This monograph is harmonized with the European Pharmacopoeia and the U.S. Pharmacopoeia.

The corresponding part of the attributes/provisions which are agreed as non-harmonized within the scope of the harmonization is marked with symbols (◆ ◆), and the corresponding parts which are agreed as the JP local requirement other than the scope of the harmonization are marked with symbols (◇ ◇).

Information on the harmonization with the European Pharmacopoeia and the U.S. Pharmacopoeia is available on the website of the Pharmaceuticals and Medical Devices Agency.

Isomalt Hydrate is a mixture of 6-*O*-α-D-glucopyranosyl-D-sorbitol and 1-*O*-α-D-glucopyranosyl-D-mannitol.

It contains not less than 98.0% and not more than 102.0% as the mixture of 6-*O*-α-D-glucopyranosyl-D-sorbitol (C₁₂H₂₄O₁₁) and 1-*O*-α-D-glucopyranosyl-D-mannitol (C₁₂H₂₄O₁₁), calculated on the anhydrous basis, and the amount of each component is not less than 3.0%, respectively.

The label states the contents (%) of 6-*O*-α-D-glucopyranosyl-D-sorbitol and 1-*O*-α-D-glucopyranosyl-D-mannitol.

◆**Description** Isomalt Hydrate occurs as a white, powder or grains.

It is freely soluble in water, and practically insoluble in ethanol (95).

Optical rotation [α]_D²⁰: about + 92° (1 g calculated on the anhydrous basis, water, 100 mL, 100 mm).◆

Identification ◇(1) To 1 mL of a solution of Isomalt Hydrate (1 in 100) add 1 mL of a solution of catechol (1 in 10) prepared before use, shake thoroughly, add 2 mL of sulfuric acid rapidly, and shake: a reddish purple to red-purple color develops.◇

(2) Perform the test with 20 μ L each of the sample solution and standard solution obtained in the Assay as directed under Liquid Chromatography <2.01> according to the following conditions, and compare the chromatograms obtained from these solutions: the two principal peaks in the chromatogram obtained from the sample solution are similar in retention time to respective two peaks from the standard solution.

Operating conditions—

Proceed as directed in the operating conditions in the Assay.

System suitability—

Proceed as directed in the system suitability in the Assay.

Purity ◇(1) Heavy metals <1.07>—Proceed with 2.0 g of Isomalt Hydrate according to Method 1, and perform the test. Prepare the control solution with 2.0 mL of Standard Lead Solution (not more than 10 ppm).◇

(2) Nickel—Weigh exactly an amount of Isomalt Hydrate, equivalent to 10.0 g calculated on the anhydrous basis, dissolve in 30 mL of 2 mol/L acetic acid TS, and add water to make exactly 100 mL. Add exactly 2 mL of a solution of ammonium pyrrolidinedithiocarbamate (1 in 100) and exactly 10 mL of water-saturated 4-methyl-2-pentanone, and shake for 30 seconds protected from light. Allow the layers to separate, and use the 4-methyl-2-pentanone layer as the sample solution. Separately, take in three vessels three exact portions of Isomalt Hydrate, each equivalent to 10.0 g calculated on the anhydrous basis, dissolve in 30 mL of 2 mol/L acetic acid TS, then add exactly 0.5 mL, 1.0 mL and 1.5 mL respectively of Standard Nickel Solution for Atomic Absorption Spectrophotometry, and add water to make them exactly 100 mL. Then, proceed in the same manner as the sample solution, and use the solutions so obtained as the standard solutions. Separately, prepare 4-methyl-2-pentanone layer by proceeding in the same manner as the sample solution but omitting the substance to be examined, and use this solution as the blank solution. Perform the test with the sample solution and standard solution as directed in the standard addition method under Atomic Absorption Spectrophotometry <2.23> according to the following conditions. The blank solution is used to set the zero of the instrument, and to ascertain that the readings return to zero after rinsing the sample introduction system with water between each measurement: the amount of nickel is not more than 1 ppm.

Gas: Combustible gas—Acetylene.

Supporting gas—Air.

Lamp: Nickel hollow-cathode lamp.

Wavelength: 232.0 nm.

(3) Related substances—Weigh exactly 0.20 g of Isomalt Hydrate, dissolve in water to make exactly 10 mL, and use this solution as the sample solution. Separately, weigh exactly 10.0 mg of D-sorbitol and 10.0 mg of D-mannitol, dissolve in water to make exactly 100 mL, and use this solution as the standard solution. Perform the test with exactly 20 μ L each of the sample solution and standard solution as directed under Liquid Chromatography <2.01> according to the following conditions, and determine each peak area by the automatic integration method: the peak areas of D-mannitol, having the relative retention time of about 1.6 to 1-O- α -D-glucopyranosyl-D-mannitol, and D-sorbitol, having the relative retention time of about 2.0, obtained from the sample

solution are not larger than the area of the corresponding peak from the standard solution (not more than 0.5%), and the area of the peak other than 1-O- α -D-glucopyranosyl-D-mannitol and 6-O- α -D-glucopyranosyl-D-sorbitol having the relative retention time of about 1.2 and the peaks mentioned above from the sample solution is not larger than the peak area of D-sorbitol from the standard solution (not more than 0.5%). In addition, the total area of the peaks other than 1-O- α -D-glucopyranosyl-D-mannitol and 6-O- α -D-glucopyranosyl-D-sorbitol from the sample solution is not larger than 4 times the peak area of D-sorbitol from the standard solution (not more than 2.0%). However, the peaks which area is not larger than 1/5 times the peak area of D-sorbitol from the standard solution are disregarded (not more than 0.1%).

Operating conditions—

Detector, column, column temperature, mobile phase, and flow rate: Proceed as directed in the operating conditions in the Assay.

Time span of measurement: About 2.5 times as long as the retention time of 1-O- α -D-glucopyranosyl-D-mannitol.

System suitability—

System performance: Proceed as directed in the system suitability in the Assay.

◇Test for required detectability: Pipet 2 mL of the standard solution, and add water to make exactly 10 mL. Confirm that the peak area of D-sorbitol obtained with 20 μ L of this solution is equivalent to 14 to 26% of that with 20 μ L the standard solution.◇

◇System repeatability: When the test is repeated 6 times with 20 μ L of the standard solution under the above operating conditions, the relative standard deviations of the peak area of D-mannitol and D-sorbitol are not more than 2.0%, respectively.◇

(4) Reducing sugars—Dissolve 3.3 g of Isomalt Hydrate in 10 mL of water with the aid of gentle heat, cool, and add 20 mL of copper (II) citrate TS. Add a few amount of boiling chips, heat so that the boiling begins after 4 minutes, and maintain boiling for 3 minutes. Cool rapidly, add 100 mL of a solution of acetic acid (100) (3 in 125) and exactly 20 mL of 0.025 mol/L iodine VS. With continuous shaking, add 25 mL of a mixture of water and hydrochloric acid (47:3). When the precipitate has dissolved, titrate <2.50> the excess of iodine with 0.05 mol/L sodium thiosulfate VS, until the blue color due to 1 mL of soluble starch TS added at near of the end point disappears: not less than 12.8 mL of 0.05 mol/L sodium thiosulfate VS is required (not more than 0.3% as glucose).

Conductivity <2.51> Dissolve 20 g of Isomalt Hydrate in a suitable amount of freshly boiled and cooled water with the aid of gentle heat at 40 – 50°C, cool, add the same water to make exactly 100 mL, and use this solution as the sample solution. Measure the conductivity (25°C) of the sample solution at 25 \pm 0.1°C while gently stirring with a magnetic stirrer: not more than 20 μ S \cdot cm⁻¹.

Water <2.48> Not more than 7.0% (0.3 g, volumetric titration, direct titration. Use a mixture of methanol for water determination and formamide for water determination (1:1) heated at 50 \pm 5°C instead of methanol for water determination).

Assay Weigh accurately about 0.2 g of Isomalt Hydrate, dissolve in water to make exactly 10 mL, and use this solution as the sample solution. Separately, weigh accurately about 0.2 g of Isomalt RS (separately determine the water <2.48> in the same manner as Isomalt Hydrate), dissolve in

water to make exactly 10 mL, and use this solution as the standard solution. Perform the test with exactly 20 μ L each of the sample solution and standard solution as directed under Liquid Chromatography <2.01> according to the following conditions, and determine the peak areas, A_{Ta} and A_{Tb} , and A_{Sa} and A_{Sb} , of 1-*O*- α -D-glucopyranosyl-D-mannitol and 6-*O*- α -D-glucopyranosyl-D-sorbitol in each solution.

Amount (g) of 1-*O*- α -D-glucopyranosyl-D-mannitol ($C_{12}H_{24}O_{11}$)
 $= M_S \times K_a / 100 \times A_{Ta} / A_{Sa}$

Amount (g) of 6-*O*- α -D-glucopyranosyl-D-sorbitol ($C_{12}H_{24}O_{11}$)
 $= M_S \times K_b / 100 \times A_{Tb} / A_{Sb}$

M_S : Amount (g) of Isomalt RS taken, calculated on the anhydrous basis

K_a : Content (%) of 1-*O*- α -D-glucopyranosyl-D-mannitol ($C_{12}H_{24}O_{11}$) in Isomalt RS

K_b : Content (%) of 6-*O*- α -D-glucopyranosyl-D-sorbitol ($C_{12}H_{24}O_{11}$) in Isomalt RS

Operating conditions—

Detector: A differential refractometer maintained at a constant temperature (40°C for example).

Column: Two stainless steel columns, 4.6 mm in inside diameter and 3 cm in length, and 7.8 mm in inside diameter and 30 cm in length, both packed with strongly acidic ion-exchange resin (Ca type) for liquid chromatography with sulfonic acid groups attached to a polymer lattice consisting of polystyrene cross-linked with divinylbenzene (degree of cross-linkage: 8%) (9 μ m in particle diameter). These are used as the pre-column and the separation column, respectively.

Column temperature: 80 \pm 3°C.

Mobile phase: Water.

Flow rate: 0.5 mL per minute (retention time of 1-*O*- α -D-glucopyranosyl-D-mannitol is about 12 minutes).

System suitability—

System performance: When the procedure is run with 20 μ L of the standard solution under the above operating conditions, 1-*O*- α -D-glucopyranosyl-D-mannitol and 6-*O*- α -D-glucopyranosyl-D-sorbitol are eluted in this order with the resolution between these peaks being not less than 2.0.

◇System repeatability: When the test is repeated 6 times with 20 μ L of the standard solution under the above operating conditions, the relative standard deviations of the peak area of 1-*O*- α -D-glucopyranosyl-D-mannitol and 6-*O*- α -D-glucopyranosyl-D-sorbitol are not more than 2.0%, respectively.◇

◆**Containers and storage** Containers—Well-closed containers.◆

Isoniazid

イソニアジド

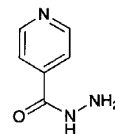

$C_6H_7N_3O$: 137.14
 Pyridine-4-carbohydrazide
 [54-85-3]

Isoniazid, when dried, contains not less than 98.5% of isoniazid ($C_6H_7N_3O$).

Description Isoniazid occurs as colorless crystals or a white crystalline powder. It is odorless.

It is freely soluble in water and in acetic acid (100), sparingly soluble in ethanol (95), slightly soluble in acetic anhydride, and very slightly soluble in diethyl ether.

Identification (1) Dissolve about 20 mg of Isoniazid in water to make 200 mL. To 5 mL of the solution add 1 mL of 0.1 mol/L hydrochloric acid TS and water to make 50 mL. Determine the absorption spectrum of the solution as directed under Ultraviolet-visible Spectrophotometry <2.24>, and compare the spectrum with the Reference Spectrum: both spectra exhibit similar intensities of absorption at the same wavelengths.

(2) Determine the infrared absorption spectrum of Isoniazid, previously dried, as directed in the potassium bromide disk method under Infrared Spectrophotometry <2.25>, and compare the spectrum with the Reference Spectrum: both spectra exhibit similar intensities of absorption at the same wave numbers.

pH <2.54> Dissolve 1.0 g of Isoniazid in 10 mL of freshly boiled and cooled water: the pH of this solution is between 6.5 and 7.5.

Melting point <2.60> 170 – 173°C

Purity (1) Clarity and color of solution—Dissolve 1.0 g of Isoniazid in 20 mL of water: the solution is clear and colorless.

(2) Heavy metals <1.07>—Proceed with 1.0 g of Isoniazid according to Method 2, and perform the test. Prepare the control solution with 2.0 mL of Standard Lead Solution (not more than 20 ppm).

(3) Arsenic <1.11>—Prepare the test solution with 0.40 g of Isoniazid according to Method 3, and perform the test. In this case, add 10 mL of a solution of magnesium nitrate hexahydrate in ethanol (95) (1 in 50), then add 1.5 mL of hydrogen peroxide (30), and ignite the ethanol to burn (not more than 5 ppm).

(4) Hydrazine—Dissolve 0.10 g of Isoniazid in 5 mL of water, add 0.1 mL of a solution of salicylaldehyde in ethanol (95) (1 in 20), shake immediately, and allow to stand for 5 minutes: no turbidity is produced.

Loss on drying <2.41> Not more than 0.5% (1 g, 105°C, 2 hours).

Residue on ignition <2.44> Not more than 0.1% (1 g).

Assay Weigh accurately about 0.3 g of Isoniazid, previously dried, dissolve in 50 mL of acetic acid (100) and 10 mL of acetic anhydride, and titrate <2.50> with 0.1 mol/L per-

chloric acid VS until the color of the solution changes from yellow to green (indicator: 0.5 mL of *p*-naphtholbenzein TS). Perform a blank determination in the same manner, and make any necessary correction.

Each mL of 0.1 mol/L perchloric acid VS
= 13.71 mg of C₆H₇N₃O

Containers and storage Containers—Tight containers.
Storage—Light-resistant.

Isoniazid Injection

イソニアジド注射液

Isoniazid Injection is an aqueous injection.

It contains not less than 95.0% and not more than 105.0% of the labeled amount of isoniazid (C₆H₇N₃O: 137.14).

Method of preparation Prepare as directed under Injections, with Isoniazid.

Description Isoniazid Injection occurs as a clear, colorless liquid.

pH: 6.5 – 7.5

Identification To a volume of Isoniazid Injection, equivalent to 20 mg of Isoniazid, and add water to make 200 mL. To 5 mL of the solution add 1 mL of 0.1 mol/L hydrochloric acid TS and water to make 50 mL. Determine the absorption spectrum of this solution as directed under Ultraviolet-visible Spectrophotometry <2.24>: it exhibits a maximum between 264 nm and 268 nm.

Bacterial endotoxins <4.01> Less than 0.50 EU/mg.

Extractable volume <6.05> It meets the requirement.

Foreign insoluble matter <6.06> Perform the test according to Method 1: it meets the requirement.

Insoluble particulate matter <6.07> It meets the requirement.

Sterility <4.06> Perform the test according to the Membrane filtration method: it meets the requirement.

Assay To an exactly measured volume of Isoniazid Injection, equivalent to about 50 mg of isoniazid (C₆H₇N₃O), add water to make exactly 100 mL. Pipet 5 mL of the solution, add exactly 5 mL of the internal standard solution and the mobile phase to make 50 mL, and use this solution as the sample solution. Separately, weigh accurately about 50 mg of isoniazid for assay, previously dried at 105°C for 2 hours, and dissolve in water to make exactly 100 mL. Pipet 5 mL of this solution, add exactly 5 mL of the internal standard solution and the mobile phase to make 50 mL, and use this solution as the standard solution. Perform the test with 5 μL each of the sample solution and standard solution as directed under Liquid Chromatography <2.01> according to the following conditions, and calculate the ratios, Q_T and Q_S , of the peak area of isoniazid to that of the internal standard.

Amount (mg) of isoniazid (C₆H₇N₃O) = $M_S \times Q_T/Q_S$

M_S : Amount (mg) of isoniazid for assay taken

Internal standard solution—A solution of propyl parahydroxybenzoate (1 in 4000).

Operating conditions—

Detector: An ultraviolet absorption photometer (wave-

length: 265 nm).

Column: A stainless steel column 4.6 mm in inside diameter and 15 cm in length, packed with octadecylsilanized silica gel for liquid chromatography (5 μm in particle diameter).

Column temperature: A constant temperature of about 40°C.

Mobile phase: Dissolve 6.80 g of potassium dihydrogen phosphate in water to make 1000 mL. Separately, to 5.76 g of phosphoric acid add water to make 1000 mL. Mix these solutions to make a solution having pH 2.5. To 500 mL of this solution add 500 mL of methanol, and add 2.86 g of sodium tridecanesulfonate to dissolve.

Flow rate: Adjust so that the retention time of isoniazid is about 5 minutes.

System suitability—

System performance: When the procedure is run with 5 μL of the standard solution under the above operating conditions, isoniazid and the internal standard are eluted in this order with the resolution between these peaks being not less than 10.

System repeatability: When the test is repeated 6 times with 5 μL of the standard solution under the above operating conditions, the relative standard deviation of the ratios of the peak area of isoniazid to that of the internal standard is not more than 1.3%.

Containers and storage Containers—Hermetic containers, and colored containers may be used.

Storage—Light-resistant.

Isoniazid Tablets

イソニアジド錠

Isoniazid Tablets contain not less than 95.0% and not more than 105.0% of the labeled amount of isoniazid (C₆H₇N₃O: 137.14).

Method of preparation Prepare as directed under Tablets, with Isoniazid.

Identification Take a quantity of powdered Isoniazid Tablets, equivalent to 20 mg of Isoniazid, add 200 mL of water, shake well, and filter. To 5 mL of the filtrate add 1 mL of 0.1 mol/L hydrochloric acid TS and water to make 50 mL, and determine the absorption spectrum of this solution as directed under Ultraviolet-visible Spectrophotometry <2.24>: it exhibits a maximum between 264 nm and 268 nm.

Uniformity of dosage units <6.02> Perform the test according to the following method: it meets the requirement of the Content uniformity test.

To 1 tablet of Isoniazid Tablets add water to make exactly V mL so that each mL contains about 0.5 mg of isoniazid (C₆H₇N₃O), and shake well to disintegrate. Filter this solution, discard the first 10 mL of the filtrate, pipet 5 mL of the subsequent filtrate, add the mobile phase to make exactly 50 mL, and use this solution as the sample solution. Proceed as directed in the Assay.

Amount (mg) of isoniazid (C₆H₇N₃O)
= $M_S \times A_T/A_S \times V/100$

M_S : Amount (mg) of isoniazid for assay taken

Dissolution <6.10> When the test is performed at 50 revolutions per minute according to the Paddle method, using 900 mL of water as the dissolution medium, the dissolution rate in 20 minutes of Isoniazid Tablets is not less than 75%.

Start the test with 1 tablet of Isoniazid Tablets, withdraw not less than 20 mL of the medium at the specified minute after starting the test, and filter through a membrane filter with a pore size of not more than 0.45 μm . Discard not less than 10 mL of the first filtrate, pipet 5 mL of the subsequent filtrate, add water to make exactly 50 mL, and use this solution as the sample solution. Separately, weigh accurately about 0.1 g of isoniazid for assay, previously dried at 105°C for 2 hours, dissolve in water to make exactly 100 mL, then pipet 5 mL of this solution, add water to make exactly 50 mL, and then pipet 5 mL of this solution, add water to make exactly 50 mL, and use this solution as the standard solution. Determine the absorbances, A_T and A_S , of the sample solution and standard solution at 267 nm as directed under Ultraviolet-visible Spectrophotometry <2.24>.

$$\begin{aligned} & \text{Dissolution rate (\%)} \text{ with respect to the labeled} \\ & \text{amount of isoniazid (C}_6\text{H}_7\text{N}_3\text{O)} \\ & = M_S \times A_T/A_S \times 1/C \times 90 \end{aligned}$$

M_S : Amount (mg) of isoniazid for assay taken

C: Labeled amount (mg) of isoniazid (C₆H₇N₃O) in 1 tablet

Assay Weigh accurately and powder not less than 20 Isoniazid Tablets. Weigh accurately a quantity of the powder, equivalent to about 0.1 g of isoniazid (C₆H₇N₃O), add 150 mL of water, shake for 30 minutes, then add water to make exactly 200 mL, and filter. Discard the first 10 mL of the filtrate, pipet 5 mL of the subsequent filtrate, add the mobile phase to make exactly 50 mL, and use this solution as the sample solution. Separately, weigh accurately about 50 mg of isoniazid for assay, previously dried at 105°C for 2 hours, dissolve in water to make exactly 100 mL. Pipet 5 mL of this solution, add the mobile phase to make exactly 50 mL, and use this solution as the standard solution. Perform the test with exactly 10 μL each of the sample solution and standard solution as directed under Liquid Chromatography <2.01> according to the following conditions. Determine the peak areas, A_T and A_S , of isoniazid in each solution.

$$\begin{aligned} & \text{Amount (mg) of isoniazid (C}_6\text{H}_7\text{N}_3\text{O)} \\ & = M_S \times A_T/A_S \times 2 \end{aligned}$$

M_S : Amount (mg) of isoniazid for assay taken

Operating conditions—

Detector: An ultraviolet absorption photometer (wavelength: 265 nm).

Column: A stainless steel column 4.6 mm in inside diameter and 25 cm in length, packed with octadecylsilanized silica gel for liquid chromatography (5 μm in particle diameter).

Column temperature: A constant temperature of about 40°C.

Mobile phase: Dissolve 6.80 g of potassium dihydrogen phosphate in water to make 1000 mL. Separately, to 5.76 g of phosphoric acid add water to make 1000 mL. Mix these solutions to adjust the pH to 2.5. To 400 mL of this solution add 600 mL of methanol, and add 2.86 g of sodium tridecanesulfonate to dissolve.

Flow rate: Adjust so that the retention time of isoniazid is about 5 minutes.

System suitability—

System performance: Dissolve 5 mg of Isoniazid and 5 mg of isonicotinic acid in 100 mL of the mobile phase. When the procedure is run with 10 μL of this solution under the above operating conditions, isonicotinic acid and isoniazid are eluted in this order with the resolution between these peaks being not less than 1.5.

System repeatability: When the test is repeated 6 times

with 10 μL of the standard solution under the above operating conditions, the relative standard deviation of the peak area of isoniazid is not more than 1.0%.

Containers and storage Containers—Tight containers.

Storage—Light-resistant.

l-Isoprenaline Hydrochloride

l-イソプレナリン塩酸塩

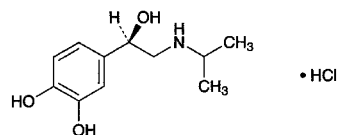

C₁₁H₁₇NO₃.HCl: 247.72

4-[(1*R*)-1-Hydroxy-

2-[(1-methylethyl)amino]ethyl]benzene-

1,2-diol monohydrochloride

[5984-95-2]

l-Isoprenaline Hydrochloride, when dried, contains not less than 98.0% of *l*-isoprenaline hydrochloride (C₁₁H₁₇NO₃.HCl).

Description *l*-Isoprenaline Hydrochloride occurs as a white, crystalline powder. It is odorless.

It is freely soluble in water, sparingly soluble in ethanol (95), and practically insoluble in acetic acid (100), in acetic anhydride, in diethyl ether and in chloroform.

It gradually changes in color by air and by light.

Identification (1) Dissolve 10 mg of *l*-Isoprenaline Hydrochloride in 5 mL of water, and add 1 drop of iron (III) chloride TS: a deep green color develops, and changes through yellow-green to brown on standing.

(2) Dissolve 1 mg each of *l*-Isoprenaline Hydrochloride in 1 mL of water in the test tubes A and B. Add 10 mL of potassium hydrogen phthalate buffer solution (pH 3.5) to A, and add 10 mL of phosphate buffer solution (pH 6.5) to B. To each of the test tubes add 1 mL of iodine TS, allow to stand for 5 minutes, and add 2 mL each of sodium thiosulfate TS: a red color develops in the test tube A, and a deep red color develops in the test tube B.

(3) Dissolve 10 mg of *l*-Isoprenaline Hydrochloride in 1 mL of water, and add 1 mL of phosphotungstic acid TS: a light brown precipitate is produced.

(4) Determine the absorption spectrum of a solution of *l*-Isoprenaline Hydrochloride in 0.1 mol/L hydrochloric acid TS (1 in 20,000) as directed under Ultraviolet-visible Spectrophotometry <2.24>, and compare the spectrum with the Reference Spectrum: both spectra exhibit similar intensities of absorption at the same wavelengths.

(5) A solution of *l*-Isoprenaline Hydrochloride (1 in 10) responds to Qualitative Tests <1.09> (2) for chloride.

Optical rotation <2.49> $[\alpha]_D^{20}$: -36 – -41° (after drying, 0.25 g, water, 25 mL, 100 mm).

pH <2.54> Dissolve 0.10 g of *l*-Isoprenaline Hydrochloride in 10 mL of water: the pH of the solution is between 4.5 and 5.5.

Purity (1) Clarity and color of solution—Dissolve 1.0 g of *l*-Isoprenaline Hydrochloride in 20 mL of 0.1 mol/L hydrochloric acid TS: the solution is clear and colorless.

(2) Sulfate <1.14>—Perform the test with 0.10 g of *l*-

Isoprenaline Hydrochloride. Prepare the control solution with 0.40 mL of 0.005 mol/L sulfuric acid VS (not more than 0.192%).

(3) Heavy metals <1.07>—Proceed with 1.0 g of *l*-Isoprenaline Hydrochloride according to Method 1, and perform the test. Prepare the control solution with 2.0 mL of Standard Lead Solution (not more than 20 ppm).

(4) Isoproterenone—Dissolve 50 mg of *l*-Isoprenaline Hydrochloride in 0.01 mol/L hydrochloric acid TS to make exactly 25 mL, and determine the absorbance of the solution at 310 nm as directed under Ultraviolet-visible Spectrophotometry <2.24>: not more than 0.040.

Loss on drying <2.41> Not more than 0.5% (1 g, in vacuum, silica gel, 4 hours).

Residue on ignition <2.44> Not more than 0.2% (1 g).

Assay Weigh accurately about 0.5 g of *l*-Isoprenaline Hydrochloride, previously dried, dissolve in 100 mL of a mixture of acetic acid (100) and acetic anhydride (3:2) by warming, cool, and titrate <2.50> with 0.1 mol/L perchloric acid VS (potentiometric titration). Perform a blank determination in the same manner, and make any necessary correction.

Each mL of 0.1 mol/L perchloric acid VS
= 24.77 mg of C₁₁H₁₇NO₃·HCl

Containers and storage Containers—Tight containers.
Storage—Light-resistant.

Isopropanol

Isopropyl Alcohol

イソプロパノール

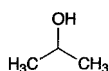

C₃H₈O: 60.10
Propan-2-ol
[67-63-0]

Description Isopropanol is a clear, colorless liquid. It has a characteristic odor.

It is miscible with water, with methanol, with ethanol (95), and with diethyl ether.

It is flammable and volatile.

Identification (1) To 1 mL of Isopropanol add 2 mL of iodine TS and 2 mL of sodium hydroxide TS, and shake: a light yellow precipitate is formed.

(2) To 5 mL of Isopropanol add 20 mL of potassium dichromate TS and 5 mL of sulfuric acid with caution, and warm gently on a water bath: the produced gas has the odor of acetone, and the gas turns the filter paper, previously wetted with a solution of salicylaldehyde in ethanol (95) (1 in 10) and with a solution of sodium hydroxide (3 in 10), to red-brown.

Specific gravity <2.56> d_{20}^{20} : 0.785 – 0.788

Purity (1) Clarity of solution—To 2.0 mL of Isopropanol add 8 mL of water, and shake: the solution is clear.

(2) Acidity—To 15.0 mL of Isopropanol add 50 mL of freshly boiled and cooled water and 2 drops of phenolphthalein TS, and add 0.40 mL of 0.01 mol/L sodium hydroxide VS: a red color develops.

(3) Residue on evaporation—Evaporate 20.0 mL of

Isopropanol on a water bath to dryness, and dry at 105°C for 1 hour: the mass of the residue is not more than 1.0 mg.

Water <2.48> Not more than 0.75 w/v% (2 mL, volumetric titration, direct titration).

Distilling range <2.57> 81 – 83°C, not less than 94 vol%.

Containers and storage Containers—Tight containers.
Storage—Remote from fire.

Isopropylantipyrene

Propyphenazone

イソプロピルアンチピリン

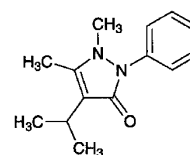

C₁₄H₁₈N₂O: 230.31
1,5-Dimethyl-4-(1-methylethyl)-2-phenyl-
1,2-dihydro-3H-pyrazol-3-one
[479-92-5]

Isopropylantipyrene, when dried, contains not less than 98.0% of isopropylantipyrene (C₁₄H₁₈N₂O).

Description Isopropylantipyrene occurs as white, crystals or crystalline powder. It is odorless, and has a slightly bitter taste.

It is very soluble in acetic acid (100), freely soluble in ethanol (95) and in acetone, soluble in diethyl ether, and slightly soluble in water.

Identification (1) To 2 mL of a solution of Isopropylantipyrene (1 in 500) add 1 drop of iron (III) chloride TS: a light red color develops. Further add 3 drops of sulfuric acid to this solution: the color changes to pale yellow.

(2) Add 5 mL of a solution of Isopropylantipyrene (1 in 500) to a mixture of 5 mL of potassium hexacyanoferrate (III) TS and 1 to 2 drops of iron (III) chloride TS: a dark green color gradually develops.

(3) To 2 mL of a solution of Isopropylantipyrene (1 in 500) add 2 to 3 drops of tannic acid TS: a white precipitate is produced.

Melting point <2.60> 103 – 105°C

Purity (1) Chloride <1.03>—Dissolve 1.0 g of Isopropylantipyrene in 30 mL of dilute ethanol, and add 6 mL of dilute nitric acid and water to make 50 mL. Perform the test using this solution as the test solution. Prepare the control solution as follows: to 0.40 mL of 0.01 mol/L hydrochloric acid VS add 6 mL of dilute nitric acid, 30 mL of dilute ethanol and water to make 50 mL (not more than 0.014%).

(2) Sulfate <1.14>—Dissolve 1.0 g of Isopropylantipyrene in 30 mL of dilute ethanol, and add 1 mL of dilute hydrochloric acid and water to make 50 mL. Perform the test using this solution as the test solution. Prepare the control solution as follows: to 0.40 mL of 0.005 mol/L sulfuric acid VS add 1 mL of dilute hydrochloric acid and 30 mL of dilute ethanol, and dilute with water to make 50 mL (not more than 0.019%).

(3) Heavy metals <1.07>—Dissolve 1.0 g of Isopropylantipyrene in 25 mL of acetone, add 2 mL of dilute acetic acid

and water to make 50 mL, and perform the test using this solution as the test solution. Prepare the control solution as follows: to 2.0 mL of Standard Lead Solution add 2 mL of dilute acetic acid, 25 mL of acetone, and dilute with water to make 50 mL (not more than 20 ppm).

(4) Arsenic <1.11>—Prepare the test solution with 1.0 g of Isopropylantipyrine according to Method 3, and perform the test (not more than 2 ppm).

(5) Antipyrine—Dissolve 1.0 g of Isopropylantipyrine in 10 mL of dilute ethanol, and add 1 mL of sodium nitrite TS and 1 mL of dilute sulfuric acid: no green color develops.

Loss on drying <2.41> Not more than 0.5% (1 g, in vacuum, silica gel, 5 hours).

Residue on ignition <2.44> Not more than 0.1% (1 g).

Assay Weigh accurately about 0.4 g of Isopropylantipyrine, previously dried, dissolve in 60 mL of a mixture of acetic acid (100) and acetic anhydride (2:1), and titrate <2.50> with 0.1 mol/L perchloric acid VS (potentiometric titration). Perform a blank determination in the same manner, and make any necessary correction.

Each mL of 0.1 mol/L perchloric acid VS
= 23.03 mg of C₁₄H₁₈N₂O

Containers and storage Containers—Tight containers.

Isosorbide

イソソルビド

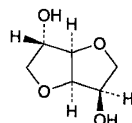

C₆H₁₀O₄: 146.14
1,4:3,6-Dianhydro-D-glucitol
[652-67-5]

Isosorbide contains not less than 98.5% of isosorbide (C₆H₁₀O₄), calculated on the anhydrous basis.

Description Isosorbide occurs as white, crystals or masses. It is odorless, or has a faint, characteristic odor, and has a bitter taste.

It is very soluble in water and in methanol, freely soluble in ethanol (95), and slightly soluble in diethyl ether.

It is hygroscopic.

Identification (1) To 0.1 g of Isosorbide add 6 mL of diluted sulfuric acid (1 in 2), and dissolve by heating in a water bath. After cooling, shake well with 1 mL of a solution of potassium permanganate (1 in 30), and heat in a water bath until the color of potassium permanganate disappears. To this solution add 10 mL of 2,4-dinitrophenylhydrazine TS, and heat in a water bath: an orange precipitate is formed.

(2) To 2 g of Isosorbide add 30 mL of pyridine and 4 mL of benzoyl chloride, boil under a reflux condenser for 50 minutes, cool, and pour gradually the solution into 100 mL of cold water. Filter the formed precipitate by suction through a glass filter (G3), wash with water, recrystallize twice from ethanol (95), and dry in a desiccator (in vacuum, silica gel) for 4 hours: it melts <2.60> between 102°C and 103°C.

(3) Determine the infrared absorption spectrum of

Isosorbide as directed in the potassium bromide disk method under Infrared Spectrophotometry <2.25>, and compare the spectrum with the Reference Spectrum: both spectra exhibit similar intensities of absorption at the same wave numbers.

Optical rotation <2.49> $[\alpha]_D^{20}$: +45.0 – +46.0° (5 g calculated on the anhydrous basis, water, 50 mL, 100 mm).

Purity (1) Clarity and color of solution—Take 25 g of Isosorbide in a Nessler tube, and dissolve in 50 mL of water: the solution is clear, and has no more color than the following control solution.

Control solution: To a mixture of 1.0 mL of Cobalt (II) Chloride CS, 3.0 mL of Iron (III) Chloride CS and 2.0 mL of Copper (II) Sulfate CS add water to make 10.0 mL. To 3.0 mL of this solution add water to make 50 mL.

(2) Sulfate <1.14>—Perform the test with 2.0 g of Isosorbide. Prepare the control solution with 1.0 mL of 0.005 mol/L sulfuric acid VS (not more than 0.024%).

(3) Heavy metals <1.07>—Proceed with 5.0 g of Isosorbide according to Method 1, and perform the test. Prepare the control solution with 2.5 mL of Standard Lead Solution (not more than 5 ppm).

(4) Arsenic <1.11>—Prepare the test solution with 1.0 g of Isosorbide according to Method 1, and perform the test (not more than 2 ppm).

(5) Related substances—Dissolve 0.10 g of Isosorbide in 10 mL of methanol, and use this solution as the sample solution. Pipet 2 mL of the sample solution, add methanol to make exactly 100 mL, and use this solution as the standard solution. Perform the test with these solutions as directed under Thin-layer Chromatography <2.03>. Spot 10 μL each of the sample solution and standard solution on a plate of silica gel for thin-layer chromatography. Develop the plate with a mixture of ethanol (95) and cyclohexane (1:1) to a distance of about 10 cm, and air-dry the plate. Spray evenly a mixture of ethanol (95) and sulfuric acid (9:1) on the plate, and heat the plate at 150°C for 30 minutes: the spots other than the principal spot obtained from the sample solution are not more intense than the spot from the standard solution.

Water <2.48> Not more than 1.5% (2 g, volumetric titration, direct titration).

Residue on ignition <2.44> Not more than 0.1% (1 g).

Assay Weigh accurately about 10 g of Isosorbide, calculated on the anhydrous basis, and dissolve in water to make exactly 100 mL. Determine the optical rotation <2.49>, α_D , of this solution at 20 ± 1°C in a 100-mm cell.

Amount (g) of isosorbide (C₆H₁₀O₄) = $\alpha_D \times 2.1978$

Containers and storage Containers—Tight containers.

Isosorbide Dinitrate

硝酸イソソルビド

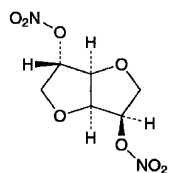

$C_6H_8N_2O_8$; 236.14

1,4:3,6-Dianhydro-D-glucitol dinitrate
[87-33-2]

Isosorbide Dinitrate contains not less than 95.0% of isosorbide dinitrate ($C_6H_8N_2O_8$), calculated on the anhydrous basis.

Description Isosorbide Dinitrate occurs as white, crystals or crystalline powder. It is odorless or has a faint odor like that of nitric acid.

It is very soluble in *N,N*-dimethylformamide and in acetone, freely soluble in chloroform and in toluene, soluble in methanol, in ethanol (95) and in diethyl ether, and practically insoluble in water.

It explodes if heated quickly or subjected to percussion.

Identification (1) Dissolve 10 mg of Isosorbide Dinitrate in 1 mL of water, and dissolve by adding 2 mL of sulfuric acid cautiously. After cooling, superimpose 3 mL of iron (II) sulfate TS, and allow to stand for 5 to 10 minutes: a brown ring is produced at the zone of contact.

(2) Dissolve 0.1 g of Isosorbide Dinitrate in 6 mL of diluted sulfuric acid (1 in 2) by heating in a water bath. After cooling, add 1 mL of a solution of potassium permanganate (1 in 30), stir well, and heat in a water bath until the color of potassium permanganate disappears. Add 10 mL of 2,4-dinitro-phenylhydrazine TS, and heat in a water bath: an orange precipitate is produced.

Optical rotation <2.49> $[\alpha]_D^{20}$: +134 – +139° (1 g calculated on the anhydrous basis, ethanol (95), 100 mL, 100 mm).

Purity (1) Clarity and color of solution—Dissolve 1.0 g of Isosorbide Dinitrate in 10 mL of acetone: the solution is clear and colorless.

(2) Sulfate <1.14>—Dissolve 1.5 g of Isosorbide Dinitrate in 15 mL of *N,N*-dimethylformamide, add 60 mL of water, cool, and filter. Wash the filter paper with three 20-mL portions of water, combine the washings with the filtrate, and add water to make 150 mL. To 40 mL of this solution add 1 mL of dilute hydrochloric acid and water to make 50 mL. Perform the test using this solution as the test solution. Prepare the control solution with 0.40 mL of 0.005 mol/L sulfuric acid VS (not more than 0.048%).

(3) Nitrate—Dissolve 50 mg of Isosorbide Dinitrate in 30 mL of toluene, and extract with three 20-mL portions of water. Combine the aqueous layers, and wash with two 20-mL portions of toluene. To the aqueous layer add water to make 100 mL, and use this solution as the sample solution. Pipet 5.0 mL of Standard Nitric Acid Solution and 25 mL of the sample solution in each Nessler tube, and add water to make 50 mL, respectively. To each of them add 60 mg of Griss-Romijn's nitric acid reagent, stir well, allow to stand for 30 minutes, and observe from the side of the Nessler tube: the sample solution has no more color than the standard solution.

(4) Heavy metals <1.07>—Dissolve 1.0 g of Isosorbide Dinitrate in 30 mL of acetone, and add 2 mL of dilute acetic acid and water to make 50 mL. Perform the test using this solution as the test solution. Prepare the control solution as follows: to 2.0 mL of Standard Lead Solution add 30 mL of acetone, 2 mL of dilute acetic acid and water to make 50 mL (not more than 20 ppm).

Water <2.48> Not more than 1.5% (0.3 g, volumetric titration, direct titration).

Assay Weigh accurately about 0.1 g of Isosorbide Dinitrate in a Kjeldahl flask as described under the Nitrogen Determination <1.08>, dissolve in 10 mL of methanol, add 3 g of Devarda's alloy and 50 mL of water, and connect the flask with the distillation apparatus as described under the Nitrogen Determination <1.08>. Measure exactly 25 mL of 0.05 mol/L sulfuric acid VS in an absorption flask, add 5 drops of bromocresol green-methyl red TS, and immerse the lower end of the condenser tube in it. Add 15 mL of a solution of sodium hydroxide (1 in 2) through the funnel, cautiously rinse the funnel with 20 mL of water, immediately close the clamp attached to the rubber tubing, then begin the distillation with steam gradually, and continue the distillation until the distillate measures 100 mL. Remove the absorption flask, rinse the end of the condenser tube with a small quantity of water, and titrate <2.50> the distillate and the rinsings with 0.1 mol/L sodium hydroxide VS until the color of the solution changes from red through light red-purple to light blue-green. Perform a blank determination in the same manner, and make any necessary correction.

Each mL of 0.05 mol/L sulfuric acid VS
= 11.81 mg of $C_6H_8N_2O_8$

Containers and storage Containers—Tight containers.
Storage—Light-resistant, and in a cold place.

Isosorbide Dinitrate Tablets

硝酸イソソルビド錠

Isosorbide Dinitrate Tablets contain not less than 93.0% and not more than 107.0% of the labeled amount of isosorbide dinitrate ($C_6H_8N_2O_8$; 236.14).

Method of preparation Prepare as directed under Tablets, with Isosorbide Dinitrate.

Identification Weigh a quantity of powdered Isosorbide Dinitrate Tablets, equivalent to 0.1 g of Isosorbide Dinitrate, add 50 mL of diethyl ether, shake well, and filter. Measure 5 mL of the filtrate, evaporate to dryness cautiously, add 1 mL of water to the residue, and dissolve by adding 2 mL of sulfuric acid cautiously. After cooling, superimpose 3 mL of iron (II) sulfate TS, and allow to stand for 5 to 10 minutes: a brown ring is produced at the zone of contact.

Purity Nitrate—Weigh accurately a quantity of powdered Isosorbide Dinitrate Tablets, equivalent to 50 mg of Isosorbide Dinitrate, transfer to a separator, add 30 mL of toluene, shake thoroughly, extract with three 20-mL portions of water, and proceed as directed in Purity (3) under Isosorbide Dinitrate.

Uniformity of dosage units <6.02> Perform the test according to the following method: it meets the requirement of the Content uniformity test.

To 1 tablet of Isosorbide Dinitrate Tablets add 1 mL of

water, and shake to disintegrate. To this solution add a mixture of water and methanol (1:1) to make exactly V mL so that each mL contains about 0.1 mg of isosorbide dinitrate ($C_6H_8N_2O_8$), and shake for 10 minutes. Centrifuge this solution, and use the supernatant liquid as the sample solution. Proceed as directed in the Assay.

$$\begin{aligned} \text{Amount (mg) of isosorbide dinitrate (C}_6\text{H}_8\text{N}_2\text{O}_8) \\ = M_S \times A_T/A_S \times V \times 1/500 \end{aligned}$$

M_S : Amount (mg) of isosorbide dinitrate for assay taken, calculated on the anhydrous basis

Disintegration <6.09> It meets the requirement.

For Sublingual Tablets, the time limit of the test is 2 minutes, and omit the use of the disk.

Assay Weigh accurately the mass of not less than 20 tablets of Isosorbide Dinitrate Tablets, and powder. Weigh accurately a portion of the powder, equivalent to about 5 mg of isosorbide dinitrate ($C_6H_8N_2O_8$), add a mixture of water and methanol (1:1) to make exactly 50 mL, and shake for 10 minutes. Centrifuge this solution, and use the supernatant liquid as the sample solution. Separately, weigh accurately about 50 mg of isosorbide dinitrate for assay (separately, determine the water <2.48> in the same manner as Isosorbide Dinitrate), dissolve in a mixture of water and methanol (1:1) to make exactly 100 mL. Pipet 10 mL of this solution, add a mixture of water and methanol (1:1) to make exactly 50 mL, and use this solution as the standard solution. Perform the test with exactly 10 μ L each of the sample solution and standard solution as directed under Liquid Chromatography <2.01> according to the following conditions, and determine the peak areas, A_T and A_S , of isosorbide dinitrate in each solution.

$$\begin{aligned} \text{Amount (mg) of isosorbide dinitrate (C}_6\text{H}_8\text{N}_2\text{O}_8) \\ = M_S \times A_T/A_S \times 1/10 \end{aligned}$$

M_S : Amount (mg) of isosorbide dinitrate for assay taken, calculated on the anhydrous basis

Operating conditions—

Detector: An ultraviolet absorption photometer (wavelength: 220 nm).

Column: A stainless steel column 4.6 mm in inside diameter and 15 cm in length, packed with octadecylsilanized silica gel for liquid chromatography (5 μ m in particle diameter).

Column temperature: A constant temperature of about 40°C.

Mobile phase: A mixture of water and methanol (11:9).

Flow rate: Adjust so that the retention time of isosorbide dinitrate is about 6 minutes.

System suitability—

System performance: When the procedure is run with 10 μ L of the standard solution under the above operating conditions, the number of theoretical plates and the symmetry factor of the peak of isosorbide dinitrate are not less than 3000 and not more than 1.5, respectively.

System repeatability: When the test is repeated 6 times with 10 μ L of the standard solution under the above operating conditions, the relative standard deviation of the peak area of isosorbide dinitrate is not more than 1.0%.

Containers and storage Containers—Tight containers.

Isosorbide Mononitrate 70%/Lactose 30%

70%—硝酸イソソルビド乳糖末

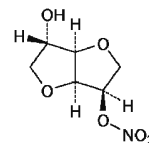

$C_6H_9NO_6$: 191.14

1,4:3,6-Dianhydro-D-glucitol 5-nitrate
[16051-77-7, Isosorbide mononitrate]

Isosorbide Mononitrate 70%/Lactose 30%, when dried, contains not less than 68.0% and not more than 72.0% of isosorbide mononitrate ($C_6H_9NO_6$).

Description Isosorbide Mononitrate 70%/Lactose 30% occurs as a white, powder, crystalline powder, or masses.

It is freely soluble in water, and practically insoluble in ethanol (99.5).

Identification (1) Shake thoroughly 1 g of Isosorbide Mononitrate 70%/Lactose 30% with 30 mL of ethyl acetate, and filter. Wash the residue with a small quantity of ethyl acetate, combine the filtrate and the washings, evaporate to dryness on a water bath, then dry in vacuum at room temperature for 4 hours. Determine the infrared absorption spectrum of the crystals obtained as directed in the potassium bromide disk method under Infrared Spectrophotometry <2.25>, and compare the spectrum with the Reference Spectrum of isosorbide mononitrate: both spectra exhibit similar intensities of absorption at the same wave numbers.

(2) Dry the residue obtained in (1) at 80°C for 2 hours. Determine the infrared absorption spectrum of the residue as directed in the potassium bromide disk method under Infrared Spectrophotometry <2.25>, and compare the spectrum with the Reference Spectrum of Lactose Hydrate or the spectrum of Lactose for Identification RS: both spectra exhibit similar intensities of absorption at the same wave numbers.

Optical rotation <2.49> $[\alpha]_D^{20}$: +116 – +124° (after drying, 1 g, water, 100 mL, 100 mm).

Purity (1) Nitrate—Dissolve an exact quantity of Isosorbide Mononitrate 70%/Lactose 30%, equivalent to 50 mg of isosorbide mononitrate ($C_6H_9NO_6$), in water to make exactly 100 mL. Pipet 25 mL of this solution, add water to make exactly 50 mL, and use this solution as the sample solution. Separately, to exactly 5 mL of Standard Nitric Acid Solution add water to make exactly 150 mL. Pipet 25 mL of this solution, add water to make exactly 150 mL, and use this solution as the standard solution. Perform the test with exactly 100 μ L each of the sample solution and standard solution as directed under Liquid Chromatography <2.01> according to the following conditions, and determine the peak area of nitric acid of each solution by the automatic integration method: the peak area of nitric acid obtained from the sample solution is not larger than the peak area of nitric acid from the standard solution.

Operating conditions—

Detector: An ultraviolet absorption photometer (wavelength: 214 nm).

Column: A stainless steel column 4.6 mm in inside diameter and 5 cm in length, packed with gel type strong basic ion-exchange resin for liquid chromatography (10 μ m in particle

diameter).

Column temperature: A constant temperature of about 35°C.

Mobile phase: Dissolve 16.0 g of sodium gluconate, 18.0 g of boric acid, 25.0 g of sodium tetraborate decahydrate, and 250 mL of glycerin in water to make 1000 mL. To 20 mL of this solution add 20 mL of 1-butanol, 120 mL of acetonitrile, and add water to make 1000 mL.

Flow rate: Adjust so that the retention time of nitric acid is about 5.3 minutes.

System suitability—

System performance: When the procedure is run with 100 μ L of the standard solution under the above operating conditions, the number of theoretical plates and the symmetry factor of the peak of nitric acid are not less than 800 and not more than 1.5, respectively.

System repeatability: When the test is repeated 6 times with 100 μ L of the standard solution under the above operating conditions, the relative standard deviation of the peak area of nitric acid is not more than 2.0%.

(2) Heavy metals <1.07>—Proceed with 1.0 g of Isosorbide Mononitrate 70%/Lactose 30% according to Method 1, and perform the test. Prepare the control solution with 1.0 mL of Standard Lead Solution (not more than 10 ppm).

(3) Isosorbide—To an amount of Isosorbide Mononitrate 70%/Lactose 30%, equivalent to 1.0 g of isosorbide mononitrate ($C_6H_9NO_6$), add 10 mL of acetone, shake well, centrifuge, and filter the supernatant liquid through a membrane filter with a pore size not exceeding 0.5 μ m. To the residue add 2 mL of acetone and proceed in the same manner, and combine the filtrates. Evaporate the combined filtrate to dryness on a water bath, and further dry the residue in vacuum for 30 minutes. Dissolve the residue in the mobile phase to make 10 mL, and use this solution as the sample solution. Pipet 1 mL of the sample solution, and add the mobile phase to make exactly 20 mL. Pipet 1 mL of this solution, add the mobile phase to make exactly 25 mL, and use this solution as the standard solution. Perform the test with exactly 20 μ L each of the sample solution and standard solution as directed under Liquid Chromatography <2.01> according to the following conditions, and determine the peak areas by the automatic integration method: the peak area of isosorbide, having the relative retention time of about 0.2 to isosorbide mononitrate, obtained from the sample solution is not larger than the peak area of isosorbide mononitrate from the standard solution.

Operating conditions—

Detector: A differential refractometer.

Column: A stainless steel column 4.6 mm in inside diameter and 25 cm in length, packed with octadecylsilanized silica gel for liquid chromatography (5 μ m in particle diameter).

Column temperature: A constant temperature of about 25°C.

Mobile phase: A mixture of water and methanol (9:1).

Flow rate: Adjust so that the retention time of isosorbide mononitrate is about 16 minutes.

System suitability—

System performance: When the procedure is run with 20 μ L of the standard solution under the above operating conditions, the number of theoretical plates and the symmetry factor of the peak of isosorbide mononitrate are not less than 5000 and not more than 2.0, respectively.

System repeatability: When the test is repeated 6 times with 20 μ L of the standard solution under the above operating conditions, the relative standard deviation of the peak area of isosorbide mononitrate is not more than 4.0%.

(4) Related substances—Dissolve an amount of Isosor-

bide Mononitrate 70%/Lactose 30%, equivalent to 50 mg of isosorbide mononitrate ($C_6H_9NO_6$), in 5 mL of water, and use this solution as the sample solution. Pipet 1 mL of the sample solution, add water to make exactly 100 mL, and use this solution as the standard solution. Perform the test with exactly 10 μ L each of the sample solution and standard solution as directed under Liquid Chromatography <2.01> according to the following conditions. Determine each peak area by the automatic integration method: the area of the peak other than isosorbide mononitrate obtained from the sample solution is not larger than 1/2 times the peak area of isosorbide mononitrate from the standard solution, and the total area of the peaks other than isosorbide mononitrate from the sample solution is not larger than the peak area of isosorbide mononitrate from the standard solution. For the area of the peak, having the relative retention time of about 4.5 to isosorbide mononitrate, multiply the correction factor, 0.62.

Operating conditions—

Detector, column, column temperature, mobile phase, and flow rate: Proceed as directed in the operating conditions in the Assay.

Time span of measurement: About 5 times as long as the retention time of isosorbide mononitrate, beginning after the solvent peak.

System suitability—

System performance: Proceed as directed in the system suitability in the Assay.

Test for required detectability: Pipet 1 mL of the standard solution, and add water to make exactly 10 mL. Confirm that the peak area of isosorbide mononitrate obtained with 10 μ L of this solution is equivalent to 7 to 13% of that with 10 μ L of the standard solution.

System repeatability: When the test is repeated 6 times with 10 μ L of the standard solution under the above operating conditions, the relative standard deviation of the peak area of isosorbide mononitrate is not more than 2.0%.

Loss on drying <2.41> Not more than 0.5% (1 g, in vacuum, silica gel, 4 hours).

Water <2.48> Between 1.0% and 2.0% (0.4 g, volumetric titration, direct titration. Use a mixture of methanol for water determination and formamide for water determination (2:1) instead of methanol for water determination).

Residue on ignition <2.44> Not more than 0.1% (0.5 g).

Assay Weigh accurately an amount of Isosorbide Mononitrate 70%/Lactose 30%, previously dried, equivalent to about 0.2 g of isosorbide mononitrate ($C_6H_9NO_6$), and dissolve in water to make exactly 50 mL. Pipet 10 mL of this solution, add exactly 20 mL of the internal standard solution, then add water to make 100 mL, and use this solution as the sample solution. Separately, weigh accurately about 40 mg of isosorbide mononitrate for assay, previously dried, and dissolve in 60 mL of water, add exactly 20 mL of the internal standard solution, then, add water to make 100 mL, and use this solution as the standard solution. Perform the test with 10 μ L each of the sample solution and standard solution as directed under Liquid Chromatography <2.01> according to the following conditions, and calculate the ratios, Q_T and Q_S , of the peak area of isosorbide mononitrate to that of the internal standard.

$$\begin{aligned} &\text{Amount (mg) of isosorbide mononitrate (C}_6\text{H}_9\text{NO}_6\text{)} \\ &= M_S \times Q_T / Q_S \times 5 \end{aligned}$$

M_S : Amount (mg) of isosorbide mononitrate for assay taken

Internal standard solution—A solution of benzyl alcohol (1 in 1000).

Operating conditions—

Detector: An ultraviolet absorption photometer (wavelength: 214 nm).

Column: A stainless steel column 4.6 mm in inside diameter and 15 cm in length, packed with octadecylsilanized silica gel for liquid chromatography (5 μ m in particle diameter).

Column temperature: A constant temperature of about 40°C.

Mobile phase: A mixture of diluted phosphoric acid (1 in 1000) and methanol (4:1).

Flow rate: Adjust so that the retention time of isosorbide mononitrate is about 4.5 minutes.

System suitability—

System performance: When the procedure is run with 10 μ L of the standard solution under the above operating conditions, isosorbide mononitrate and the internal standard are eluted in this order with the resolution between these peaks being not less than 10.

System repeatability: When the test is repeated 6 times with 10 μ L of the standard solution under the above operating conditions, the relative standard deviation of the ratio of the peak area of isosorbide mononitrate to that of the internal standard is not more than 1.0%.

Containers and storage Containers—Tight containers.

Isosorbide Mononitrate Tablets

—硝酸イソソルビド錠

Isosorbide Mononitrate Tablets contain not less than 95.0% and not more than 105.0% of the labeled amount of isosorbide mononitrate ($C_6H_9NO_6$; 191.14).

Method of preparation Prepare as directed under Tablets, with Isosorbide Mononitrate 70%/Lactose 30%.

Identification Shake well a portion of powdered Isosorbide Mononitrate Tablets, equivalent to 50 mg of isosorbide mononitrate ($C_6H_9NO_6$), with 5 mL of acetone, centrifuge, and use the supernatant liquid as the sample solution. Separately, dissolve 10 mg of isosorbide mononitrate for assay in 1 mL of acetone, and use this solution as the standard solution. Perform the test with these solutions as directed under Thin-layer Chromatography <2.03>. Spot 20 μ L each of the sample solution and standard solution on a plate of silica gel for thin-layer chromatography. Develop the plate with a mixture of ethyl acetate and hexane (2:1) to a distance of about 15 cm, and air-dry the plate. Spray evenly a solution of potassium permanganate in potassium hydroxide TS (1 in 50), and allow to stand for about 50 minutes: the principal spot obtained with the sample solution and the spot from the standard solution are yellow, and their R_f values are the same.

Uniformity of dosage units <6.02> Perform the test according to the following method: it meets the requirement of the Content uniformity test.

To 1 tablet of Isosorbide Mononitrate Tablets add 30 mL of water, allow standing to disintegrate the tablet, and disperse the fine particles by sonicating. Add exactly $V/10$ mL of the internal standard solution, and add water to make V mL so that each mL contains about 0.2 mg of isosorbide mononitrate ($C_6H_9NO_6$). Centrifuge this solution, filter the supernatant liquid through a membrane filter with a pore

size not exceeding 0.45 μ m, discard the first 10 mL of the filtrate, and use the subsequent filtrate as the sample solution. Separately, weigh accurately about 20 mg of isosorbide mononitrate for assay, previously dried in vacuum (silica gel) for 4 hours, add 30 mL of water and exactly 10 mL of the internal standard solution, then add water to make 100 mL, and use this solution as the standard solution. Then, proceed as directed in the Assay.

$$\begin{aligned} &\text{Amount (mg) of isosorbide mononitrate (C}_6\text{H}_9\text{NO}_6) \\ &= M_S \times Q_T/Q_S \times V/100 \end{aligned}$$

M_S : Amount (mg) of isosorbide mononitrate for assay taken

Internal standard solution—A solution of benzyl alcohol (1 in 1000).

Dissolution <6.10> When the test is performed at 50 revolutions per minute according to the Paddle method, using 900 mL of water as the dissolution medium, the dissolution rate in 15 minutes of Isosorbide Mononitrate Tablets is not less than 85%.

Start the test with 1 tablet of Isosorbide Mononitrate Tablets, withdraw not less than 20 mL of the medium at the specified minute after starting the test, and filter through a membrane filter with a pore size not exceeding 0.45 μ m. Discard not less than 10 mL of the first filtrate, pipet V mL of the subsequent filtrate, add water to make exactly V' mL so that each mL contains about 11 μ g of isosorbide mononitrate ($C_6H_9NO_6$), and use this solution as the sample solution. Separately, weigh accurately about 22 mg of isosorbide mononitrate for assay, previously dried in vacuum (silica gel) for 4 hours, and dissolve in water to make exactly 100 mL. Pipet 5 mL of this solution, add water to make exactly 100 mL, and use this solution as the standard solution. Perform the test with exactly 15 μ L each of the sample solution and standard solution as directed under Liquid Chromatography <2.01> according to the following conditions, and determine the peak areas, A_T and A_S , of isosorbide mononitrate in each solution.

$$\begin{aligned} &\text{Dissolution rate (\%)} \text{ with respect to the labeled amount} \\ &\text{of isosorbide mononitrate (C}_6\text{H}_9\text{NO}_6) \\ &= M_S \times A_T/A_S \times V'/V \times 1/C \times 45 \end{aligned}$$

M_S : Amount (mg) of isosorbide mononitrate for assay taken

C : Labeled amount (mg) of isosorbide mononitrate ($C_6H_9NO_6$) in 1 tablet

Operating conditions—

Proceed as directed in the operating conditions in the Assay.

System suitability—

System performance: When the procedure is run with 15 μ L of the standard solution under the above operating conditions, the number of theoretical plates and the symmetry factor of the peak of isosorbide mononitrate are not less than 2000 and not more than 1.5, respectively.

System repeatability: When the test is repeated 6 times with 15 μ L of the standard solution under the above operating conditions, the relative standard deviation of the peak area of isosorbide mononitrate is not more than 2.0%.

Assay Weigh accurately the mass of not less than 20 Isosorbide Mononitrate Tablets, and powder. Weigh accurately a portion of the powder, equivalent to about 20 mg of isosorbide mononitrate ($C_6H_9NO_6$), add 30 mL of water, and disperse the fine particles by sonicating. Add exactly 10 mL of the internal standard solution and water to make 50 mL.

Centrifuge this solution, and filter the supernatant liquid through a membrane filter with a pore size not exceeding $0.45\ \mu\text{m}$. Discard the first 10 mL of the filtrate, and use the subsequent filtrate as the sample solution. Separately, weigh accurately about 20 mg of isosorbide mononitrate for assay, previously dried, and dissolve in 30 mL of water, add exactly 10 mL of the internal standard solution, then, add water to make 50 mL, and use this solution as the standard solution. Perform the test with $10\ \mu\text{L}$ each of the sample solution and standard solution as directed under Liquid Chromatography <2.01> according to the following conditions, and calculate the ratios, Q_T and Q_S , of the peak area of isosorbide mononitrate to that of the internal standard.

$$\begin{aligned} \text{Amount (mg) of isosorbide mononitrate (C}_6\text{H}_9\text{NO}_6) \\ = M_S \times Q_T / Q_S \end{aligned}$$

M_S : Amount (mg) of isosorbide mononitrate for assay taken

Internal standard solution—A solution of benzyl alcohol (1 in 1000).

Operating conditions—

Detector: An ultraviolet absorption photometer (wavelength: 214 nm).

Column: A stainless steel column 4.6 mm in inside diameter and 15 cm in length, packed with octadecylsilanized silica gel for liquid chromatography ($5\ \mu\text{m}$ in particle diameter).

Column temperature: A constant temperature of about 40°C .

Mobile phase: A mixture of diluted phosphoric acid (1 in 1000) and methanol (4:1).

Flow rate: Adjust so that the retention time of isosorbide mononitrate is about 4.5 minutes.

System suitability—

System performance: When the procedure is run with $10\ \mu\text{L}$ of the standard solution under the above operating conditions, isosorbide mononitrate and the internal standard are eluted in this order with the resolution between these peaks being not less than 10.

System repeatability: When the test is repeated 6 times with $10\ \mu\text{L}$ of the standard solution under the above operating conditions, the relative standard deviation of the ratio of the peak area of isosorbide mononitrate to that of the internal standard is not more than 1.0%.

Containers and storage Containers—Tight containers.

Isoxsuprine Hydrochloride

イソクスプリン塩酸塩

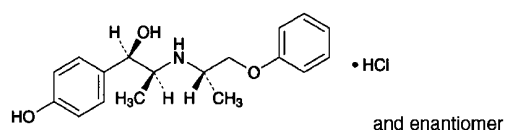

$\text{C}_{18}\text{H}_{23}\text{NO}_3 \cdot \text{HCl}$: 337.84

(1*RS*,2*SR*)-1-(4-Hydroxyphenyl)-2-[[2*SR*]-1-phenoxypropan-2-yl]amino]propan-1-ol monohydrochloride
[579-56-6]

Isoxsuprine Hydrochloride, when dried, contains not less than 99.0% and not more than 101.0% of isoxsuprine hydrochloride ($\text{C}_{18}\text{H}_{23}\text{NO}_3 \cdot \text{HCl}$).

Description Isoxsuprine Hydrochloride occurs as a white,

powder or crystalline powder.

It is soluble in formic acid and in methanol, and slightly soluble in water and in ethanol (99.5).

Melting point: about 204°C (with decomposition).

A solution of Isoxsuprine Hydrochloride in methanol (1 in 50) shows no optical rotation.

Identification (1) Determine the absorption spectrum of a solution of Isoxsuprine Hydrochloride (1 in 20,000) as directed under Ultraviolet-visible Spectrophotometry <2.24>, and compare the spectrum with the Reference Spectrum: both spectra exhibit similar intensities of absorption at the same wavelengths.

(2) Determine the infrared absorption spectrum of Isoxsuprine Hydrochloride as directed in the potassium chloride disk method under Infrared Spectrophotometry <2.25>, and compare the spectrum with the Reference Spectrum: both spectra exhibit similar intensities of absorption at the same wave numbers.

(3) Dissolve 0.5 g of Isoxsuprine Hydrochloride in 50 mL of water by warming, and cool: the solution responds to Qualitative Tests <1.09> (2) for chloride.

pH <2.54> Dissolve 0.5 g of Isoxsuprine Hydrochloride in 50 mL of water by warming, and cool: the pH of the solution is between 4.5 and 6.0.

Purity (1) Clarity and color of solution—Dissolve 0.1 g of Isoxsuprine Hydrochloride in 10 mL of water, warm if necessary, and cool: the solution is clear and colorless.

(2) Heavy metals <1.07>—Proceed with 1.0 g of Isoxsuprine Hydrochloride according to Method 2, and perform the test. Prepare the control solution with 2.0 mL of Standard Lead Solution (not more than 20 ppm).

(3) Related substances—Dissolve 20 mg of Isoxsuprine Hydrochloride in 20 mL of the mobile phase, and use this solution as the sample solution. Pipet 1 mL of the sample solution, add the mobile phase to make exactly 100 mL, and use this solution as the standard solution. Perform the test with exactly $10\ \mu\text{L}$ each of the sample solution and standard solution as directed under Liquid Chromatography <2.01> according to the following conditions. Determine each peak area by the automatic integration method: each peak area other than isoxsuprine obtained from the sample solution is not larger than the peak area of isoxsuprine from the standard solution, and the total area of the peaks other than the peak of isoxsuprine from the sample solution is not larger than 2 times the peak area of isoxsuprine from the standard solution.

Operating conditions—

Detector: An ultraviolet absorption photometer (wavelength: 269 nm).

Column: A stainless steel column 4.6 mm in inside diameter and 25 cm in length, packed with octadecylsilanized silica gel for liquid chromatography ($5\ \mu\text{m}$ in particle diameter).

Column temperature: A constant temperature of about 40°C .

Mobile phase: Dissolve 4.3 g of diammonium hydrogen phosphate and 3.2 g of sodium 1-pentane sulfonate in water to make 1000 mL, and adjust to pH 2.5 with phosphoric acid. To 770 mL of this solution add 230 mL of acetonitrile.

Flow rate: Adjust so that the retention time of isoxsuprine is about 18 minutes.

Time span of measurement: About 3 times as long as the retention time of isoxsuprine, beginning after the solvent peak.

System suitability—

Test for required detectability: Pipet 1 mL of the standard

solution, and add the mobile phase to make exactly 10 mL. Confirm that the peak area of isoxsuprine obtained with 10 μ L of this solution is equivalent to 7 to 13% of that with 10 μ L of the standard solution.

System performance: To 1 mL of the sample solution add 2.5 mL of a solution of methyl parahydroxybenzoate (1 in 25,000) and the mobile phase to make 50 mL. When the procedure is run with 10 μ L of this solution under the above operating conditions, methyl parahydroxybenzoate and isoxsuprine are eluted in this order with the resolution between these peaks being not less than 4.

System repeatability: When the test is repeated 6 times with 10 μ L of the standard solution under the above operating conditions, the relative standard deviation of the peak area of isoxsuprine is not more than 2.5%.

Loss on drying <2.41> Not more than 0.5% (1 g, 105°C, 1 hour).

Residue on ignition <2.44> Not more than 0.2% (1 g).

Assay Weigh accurately about 0.3 g of Isoxsuprine Hydrochloride, previously dried, dissolve in 5 mL of formic acid, add 50 mL of a mixture of acetic anhydride and acetic acid (100) (7:3), and titrate <2.50> with 0.1 mol/L perchloric acid VS (potentiometric titration). Perform a blank determination in the same manner, and make any necessary correction.

$$\begin{aligned} \text{Each mL of 0.1 mol/L perchloric acid VS} \\ = 33.78 \text{ mg of } C_{18}H_{23}NO_3 \cdot HCl \end{aligned}$$

Containers and storage Containers—Well-closed containers.

Isoxsuprine Hydrochloride Tablets

イソクスプリン塩酸塩錠

Isoxsuprine Hydrochloride Tablets contain not less than 95.0% and not more than 105.0% of the labeled amount of isoxsuprine hydrochloride ($C_{18}H_{23}NO_3 \cdot HCl$; 337.84).

Method of preparation Prepare as directed under Tablets, with Isoxsuprine Hydrochloride.

Identification To a quantity of powdered Isoxsuprine Hydrochloride Tablets, equivalent to 10 mg of Isoxsuprine Hydrochloride, add 150 mL of water, shake, and then add water to make 200 mL. Centrifuge this solution, filter the supernatant liquid through a membrane filter with a pore size not exceeding 0.45 μ m, discard the first 10 mL of filtrate, and determine the absorption spectrum of the subsequent filtrate as directed under Ultraviolet-visible Spectrophotometry <2.24>: it exhibits maxima between 267 nm and 271 nm, and between 272 nm and 276 nm.

Uniformity of dosage units <6.02> Perform the test according to the following method: it meets the requirement of the Content uniformity test.

Add methanol to 1 tablet of Isoxsuprine Hydrochloride Tablets, and shake to disintegrate. Add methanol to make exactly V mL so that each mL contains about 0.4 mg of isoxsuprine hydrochloride ($C_{18}H_{23}NO_3 \cdot HCl$). Centrifuge this solution, and use the supernatant liquid as the sample solution. Then, proceed as directed in the Assay.

$$\begin{aligned} \text{Amount (mg) of isoxsuprine hydrochloride} \\ (C_{18}H_{23}NO_3 \cdot HCl) \\ = M_S \times A_T/A_S \times V \times 1/100 \end{aligned}$$

M_S : Amount (mg) of isoxsuprine hydrochloride for assay taken

Dissolution <6.10> When the test is performed at 50 revolutions per minute according to the Paddle method, using 900 mL of water as the dissolution medium, the dissolution rate in 15 minutes of Isoxsuprine Hydrochloride Tablets is not less than 80%.

Start the test with 1 tablet of Isoxsuprine Hydrochloride Tablets, withdraw not less than 20 mL of the medium at the specified minute after starting the test, and filter through a membrane filter with a pore size not exceeding 0.45 μ m. Discard not less than 10 mL of the first filtrate, pipet V' mL of the subsequent filtrate, add water to make exactly V' mL so that each mL contains about 11 μ g of isoxsuprine hydrochloride ($C_{18}H_{23}NO_3 \cdot HCl$), and use this solution as the sample solution. Separately, weigh accurately about 28 mg of isoxsuprine hydrochloride for assay, previously dried at 105°C for 1 hour, and dissolve in water to make exactly 100 mL. Pipet 4 mL of this solution, add water to make exactly 100 mL, and use this solution as the standard solution. Perform the test with exactly 10 μ L each of the sample solution and standard solution as directed under Liquid Chromatography <2.01> according to the following conditions, and determine the peak areas, A_T and A_S , of isoxsuprine in each solution.

$$\begin{aligned} \text{Dissolution rate (\%)} \text{ with respect to the labeled amount} \\ \text{of isoxsuprine hydrochloride } (C_{18}H_{23}NO_3 \cdot HCl) \\ = M_S \times A_T/A_S \times V'/V \times 1/C \times 36 \end{aligned}$$

M_S : Amount (mg) of isoxsuprine hydrochloride for assay taken

C : Labeled amount (mg) of isoxsuprine hydrochloride ($C_{18}H_{23}NO_3 \cdot HCl$) in 1 tablet

Operating conditions—

Proceed as directed in the operating conditions in the Assay.

System suitability—

System performance: When the procedure is run with 10 μ L of the standard solution under the above operating conditions, the number of theoretical plates and the symmetry factor of the peak of isoxsuprine are not less than 2000 and not more than 2.0, respectively.

System repeatability: When the test is repeated 6 times with 10 μ L of the standard solution under the above operating conditions, the relative standard deviation of the peak area of isoxsuprine is not more than 2.0%.

Assay Weigh accurately not less than 20 Isoxsuprine Hydrochloride Tablets, and powder. Weigh accurately a portion of the powder, equivalent to about 40 mg of isoxsuprine hydrochloride ($C_{18}H_{23}NO_3 \cdot HCl$), add 60 mL of methanol, shake for 20 minutes, and then add methanol to make exactly 100 mL. Centrifuge a portion of this solution, filter the supernatant liquid through a membrane filter with a pore size not exceeding 0.45 μ m, discard the first 10 mL of filtrate, and use the subsequent filtrate as the sample solution. Separately, weigh accurately about 40 mg of isoxsuprine hydrochloride for assay, previously dried at 105°C for 1 hour, and dissolve in methanol to make exactly 100 mL. Filter through a membrane filter with a pore size not exceeding 0.45 μ m, discard the first 10 mL of the filtrate, and use the subsequent filtrate as the standard solution. Perform the test with exactly 10 μ L each of the sample solution and standard solution as directed under Liquid Chromatography <2.01> according to the following conditions, and determine the peak areas, A_T and A_S , of isoxsuprine in each solution.

$$\begin{aligned} & \text{Amount (mg) of isoxsuprine hydrochloride} \\ & (\text{C}_{18}\text{H}_{23}\text{NO}_3 \cdot \text{HCl}) \\ & = M_S \times A_T/A_S \end{aligned}$$

M_S : Amount (mg) of isoxsuprine hydrochloride for assay taken

Operating conditions—

Detector: An ultraviolet absorption photometer (wavelength: 269 nm).

Column: A stainless steel column 4.6 mm in inside diameter and 15 cm in length, packed with octadecylsilanized silica gel for liquid chromatography (5 μm in particle diameter).

Column temperature: A constant temperature of about 40°C.

Mobile phase: Dissolve 4.3 g of diammonium hydrogen phosphate and 3.2 g of sodium 1-pentane sulfonate in water to make 1000 mL, and adjust to pH 2.5 with phosphoric acid. To 600 mL of this solution add 400 mL of methanol.

Flow rate: Adjust so that the retention time of isoxsuprine is about 9 minutes.

System suitability—

System performance: To exactly 1 mL of the standard solution add the mobile phase to make exactly 50 mL. When the procedure is run with 10 μL of this solution under the above operating conditions, the number of theoretical plates and the symmetry factor of the peak of isoxsuprine are not less than 2000 and not more than 2.0, respectively.

System repeatability: When the test is repeated 6 times with 10 μL of the standard solution under the above operating conditions, the relative standard deviation of the peak area of isoxsuprine is not more than 1.0%.

Containers and storage Containers—Well-closed containers.

Itraconazole

イトラコナゾール

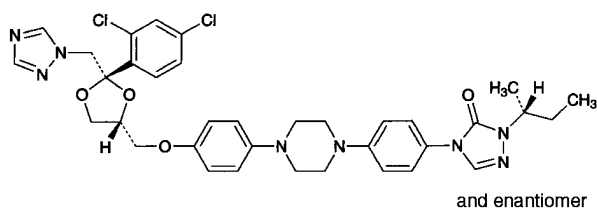
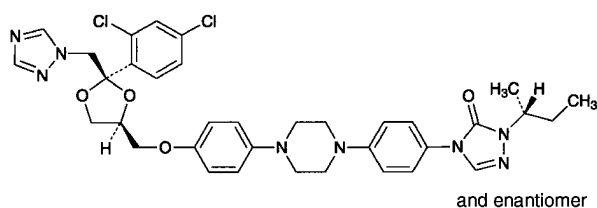

$\text{C}_{35}\text{H}_{38}\text{Cl}_2\text{N}_8\text{O}_4$; 705.63

4-(4-[4-[(2*RS*,4*SR*)-2-(2,4-Dichlorophenyl)-2-[(1*H*-1,2,4-triazol-1-yl)methyl]-1,3-dioxolan-4-yl)methoxy]phenyl]piperazin-1-yl)phenyl)-2-[(1*RS*)-1-methylpropyl]-2,4-dihydro-3*H*-1,2,4-triazol-3-one
4-(4-[4-[(2*SR*,4*RS*)-2-(2,4-Dichlorophenyl)-2-[(1*H*-1,2,4-triazol-1-yl)methyl]-1,3-dioxolan-4-yl)methoxy]phenyl]piperazin-1-yl)phenyl)-2-[(1*RS*)-1-methylpropyl]-2,4-dihydro-3*H*-1,2,4-triazol-3-one
[84625-61-6]

Itraconazole contains not less than 98.5% and not more

than 101.0% of itraconazole ($\text{C}_{35}\text{H}_{38}\text{Cl}_2\text{N}_8\text{O}_4$), calculated on the dried basis.

Description Itraconazole occurs as a white powder.

It is soluble in *N,N*-dimethylformamide, very slightly soluble in ethanol (99.5), and practically insoluble in water and in 2-propanol.

A solution of Itraconazole in *N,N*-dimethylformamide (1 in 100) shows no optical rotation.

Identification (1) Determine the absorption spectrum of a solution of Itraconazole in 2-propanol (1 in 100,000) as directed under Ultraviolet-visible Spectrophotometry <2.24>, and compare the spectrum with the Reference Spectrum: both spectra exhibit similar intensities of absorption at the same wavelengths.

(2) Determine the infrared absorption spectrum of Itraconazole, previously dried, as directed in the potassium bromide disk method under Infrared Spectrophotometry <2.25>, and compare the spectrum with the Reference Spectrum: both spectra exhibit similar intensities of absorption at the same wave numbers.

(3) Perform the test with Itraconazole as directed under Flame Coloration Test <1.04> (2): a green color appears.

Melting point <2.60> 166 – 170°C

Purity (1) Heavy metals <1.07>—Proceed with 1.0 g of Itraconazole according to Method 2, and perform the test. Prepare the control solution with 2.0 mL of Standard Lead Solution (not more than 20 ppm).

(2) Related substances—Dissolve 0.10 g of Itraconazole in 10 mL of a mixture of methanol and tetrahydrofuran (1:1), and use this solution as the sample solution. Pipet 1 mL of the sample solution, add the mixture of methanol and tetrahydrofuran (1:1) to make exactly 100 mL. Pipet 5 mL of this solution, add the mixture of methanol and tetrahydrofuran (1:1) to make exactly 10 mL, and use this solution as the standard solution. Perform the test with exactly 10 μL each of the sample solution and standard solution as directed under Liquid Chromatography <2.01> according to the following conditions. Determine each peak area of each solution by the automatic integration method: the area of each peak other than itraconazole obtained from the sample solution is not larger than the peak area of itraconazole from the standard solution. Furthermore, the total area of the peaks other than itraconazole from the sample solution is not larger than 2.5 times the peak area of itraconazole from the standard solution.

Operating conditions—

Detector: An ultraviolet absorption photometer (wavelength: 225 nm).

Column: A stainless steel column 4.6 mm in inside diameter and 10 cm in length, packed with octadecylsilanized silica gel for liquid chromatography (3 μm in particle diameter).

Column temperature: A constant temperature of about 30°C.

Mobile phase A: A solution of tetrabutylammonium hydrogensulfate (17 in 625).

Mobile phase B: Acetonitrile.

Flowing of mobile phase: Control the gradient by mixing the mobile phases A and B as directed in the following table.

Time after injection of sample (min)	Mobile phase A (vol%)	Mobile phase B (vol%)
0 – 20	80 → 50	20 → 80
20 – 25	50	50

with 10 μL of this solution is equivalent to 8 to 12% of that with 10 μL of the solution for system suitability test.

System performance: Dissolve about 0.05 g of Josamycin in 50 mL of 0.1 mol/L potassium dihydrogen phosphate TS (pH 2.0) and allow to stand at 40°C for 3 hours. Adjust the pH of this solution to 6.8 to 7.2 with 2 mol/L sodium hydroxide TS, and add 50 mL of methanol. When the procedure is run with 10 μL of this solution under the above operating conditions, the resolution between the peaks of josamycin S₁, which relative retention time to josamycin is about 0.9, and josamycin is not less than 1.5.

System repeatability: When the test is repeated 6 times with 10 μL of the solution for system suitability test under the above operating conditions, the relative standard deviation of the peak areas of josamycin is not more than 1.5%.

Loss on drying <2.41> Not more than 1.0% (0.5 g, in vacuum, phosphorus (V) oxide, 60°C, 3 hours).

Residue on ignition <2.44> Not more than 0.1% (1 g).

Assay Perform the test according to the Cylinder-plate method as directed under Microbial Assay for Antibiotics <4.02> according to the following conditions.

(i) Test organism—*Bacillus subtilis* ATCC 6633

(ii) Culture medium—Use the medium ii in 3) Medium for other organisms under (1) Agar media for seed and base layer. Adjust the pH of the medium so that it will be 7.9 to 8.1 after sterilization.

(iii) Standard solutions—Weigh accurately an amount of Josamycin RS, equivalent to about 30 mg (potency), dissolve in 5 mL of methanol, add water to make exactly 100 mL, and use this solution as the standard stock solution. Keep the standard stock solution at 5°C or below, and use within 7 days. Take exactly a suitable amount of the standard stock solution before use, add water to make solutions so that each mL contains 30 μg (potency) and 7.5 μg (potency), and use these solutions as the high concentration standard solution and the low concentration standard solution, respectively.

(iv) Sample solutions—Weigh accurately an amount of Josamycin, equivalent to about 30 mg (potency), dissolve in 5 mL of methanol, and add water to make exactly 100 mL. Take exactly a suitable amount of this solution, add water to make solutions so that each mL contains 30 μg (potency) and 7.5 μg (potency), and use these solutions as the high concentration sample solution and the low concentration sample solution, respectively.

Containers and storage Containers—Tight containers.

Storage—Light-resistant.

Josamycin Tablets

ジヨサマイシン錠

Josamycin Tablets contain not less than 90.0% and not more than 110.0% of the labeled potency of josamycin (C₄₂H₆₉NO₁₅: 827.99).

Method of preparation Prepare as directed under Tablets, with Josamycin.

Identification To a quantity of powdered Josamycin Tablets, equivalent to 10 mg (potency) of Josamycin, add 100 mL of methanol, shake vigorously, and centrifuge. To 5 mL of the supernatant liquid, add methanol to make 50 mL, and determine the absorption spectrum of this solution as directed under Ultraviolet-visible Spectrophotometry <2.24>: it

exhibits a maximum between 229 nm and 233 nm.

Loss on drying <2.41> Not more than 5.0% (0.5 g, in vacuum, 60°C, 3 hours).

Uniformity of dosage units <6.02>—Perform the test according to the following method: it meets the requirement of the Content uniformity test.

Take 1 tablet of Josamycin Tablets, add 5 mL of water, and shake vigorously to disintegrate the tablet. Add methanol and sonicate to disperse the particles, add methanol to make exactly V mL so that each mL contains about 2 mg (potency) of Josamycin, and centrifuge. Pipet 3 mL of the supernatant liquid, and add methanol to make exactly 100 mL. Pipet 10 mL of this solution, add methanol to make exactly 50 mL, and use this solution as the sample solution. Separately, accurately weigh about 50 mg (potency) of Josamycin RS, dissolve in 5 mL of water and methanol to make exactly 25 mL. Pipet 3 mL of this solution, and add methanol to make exactly 100 mL. Pipet 10 mL of this solution, add methanol to make exactly 50 mL, and use this solution as the standard solution. Determine the absorbances, A_T and A_S , of the sample solution and standard solution at 231 nm as directed under Ultraviolet-visible Spectrophotometry <2.24>. However, \bar{X} in the formula for calculation of acceptance value is the result of the assay.

$$\begin{aligned} \text{Amount [mg (potency)] of josamycin (C}_{42}\text{H}_{69}\text{NO}_{15}) \\ = M_S \times A_T/A_S \times V/25 \end{aligned}$$

M_S : Amount [mg (potency)] of Josamycin RS taken

Disintegration <6.09> Perform the test using the disk: it meets the requirement.

Assay Perform the test according to the Cylinder-plate method as directed under Microbial Assay for Antibiotics <4.02> according to the following conditions.

(i) Test organism, culture medium, and standard solutions—Proceed as directed in the Assay under Josamycin.

(ii) Sample solutions—Weigh accurately the mass of not less than 20 Josamycin Tablets and powder. Weigh accurately a portion of the powder, equivalent to about 0.3 g (potency) of Josamycin, add 50 mL of methanol, shake vigorously, and add water to make exactly 1000 mL. Take exactly an appropriate amount of this solution, add water to prepare solutions containing 30 μg (potency) and 7.5 μg (potency) per mL, and use these solutions as the high and the low concentration sample solutions, respectively.

Containers and storage Containers—Tight containers.

Josamycin Propionate

ジョサマイシンプロピオン酸エステル

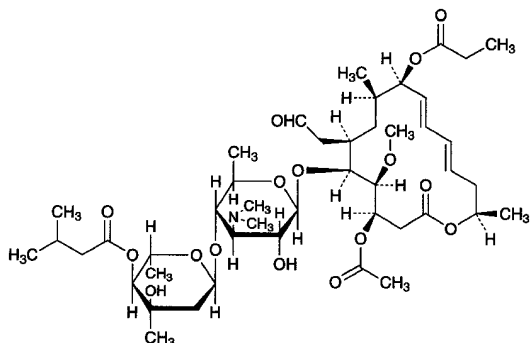

$C_{45}H_{73}NO_{16}$; 884.06

(3*R*,4*S*,5*S*,6*R*,8*R*,9*R*,10*E*,12*E*,15*R*)-3-Acetoxy-5-[2,6-dideoxy-4-*O*-(3-methylbutanoyl)-3-*C*-methyl- α -*L*-ribo-hexopyranosyl-(1 \rightarrow 4)-3,6-dideoxy-3-dimethylamino- β -*D*-glucopyranosyloxy]-6-formylmethyl-4-methoxy-8-methyl-9-propanoyloxyhexadeca-10,12-dien-15-olide

[16846-24-5, Josamycin]

Josamycin Propionate is a derivative of josamycin.

It contains not less than 843 μ g (potency) and not more than 1000 μ g (potency) per mg, calculated on the dried basis. The potency of Josamycin Propionate is expressed as mass (potency) of josamycin ($C_{42}H_{69}NO_{15}$; 827.99).

Description Josamycin Propionate occurs as a white to light yellow-white crystalline powder.

It is very soluble in acetonitrile, freely soluble in methanol and in ethanol (99.5), and practically insoluble in water.

Identification (1) Determine the absorption spectrum of a solution of Josamycin Propionate in methanol (1 in 100,000) as directed under Ultraviolet-visible Spectrophotometry <2.24>, and compare the spectrum with the Reference Spectrum or the spectrum of a solution of Josamycin Propionate RS prepared in the same manner as the sample solution: both spectra exhibit similar intensities of absorption at the same wavelengths.

(2) Dissolve 5 mg each of Josamycin Propionate and Josamycin Propionate RS in 50 mL of diluted acetonitrile (1 in 2), and use these solutions as the sample solution and the standard solution, respectively. Perform the test with 10 μ L each of the sample solution and standard solution as directed under Liquid Chromatography <2.01> according to the following conditions, and compare the chromatograms obtained from these solutions: the retention time of the peak of josamycin propionate from the sample solution is the same with that of the peak of josamycin propionate from the standard solution.

Operating conditions—

Detector, column, column temperature, mobile phase, and flow rate: Proceed as directed in the operating conditions in the Purity (2).

Purity (1) Heavy metals <1.07>—Proceed with 1.0 g of Josamycin Propionate according to Method 2, and perform the test. Prepare the control solution with 3.0 mL of Standard Lead Solution (not more than 30 ppm).

(2) Related substances—Dissolve 50 mg of Josamycin Propionate in the mobile phase to make 50 mL, and use this

solution as the sample solution. Perform the test with 10 μ L of the sample solution as directed under Liquid Chromatography <2.01> according to the following conditions. Determine each peak area by the automatic integration method, and calculate the amounts of each peak other than josamycin propionate by the area percentage method: the amount of any peak other than josamycin is not more than 6%, and the total of these peaks is not more than 22%.

Operating conditions—

Detector: An ultraviolet absorption photometer (wavelength: 234 nm).

Column: A stainless steel column 6 mm in inside diameter and 15 cm in length, packed with octadecylsilanized silica gel for liquid chromatography (5 μ m in particle diameter).

Column temperature: A constant temperature of about 40°C.

Mobile phase: To 10 mL of triethylamine add water to make 1000 mL, and adjust the pH to 4.3 with acetic acid (100). To 500 mL of this solution add 500 mL of acetonitrile.

Flow rate: Adjust so that the retention time of josamycin propionate is about 24 minutes.

Time span of measurement: About 3.5 times as long as the retention time of josamycin propionate, beginning after the solvent peak.

System suitability—

Test for required detectability: Measure 3 mL of the sample solution, add the mobile phase to make 50 mL, and use this solution as the solution for system suitability test. Measure exactly 2 mL of the solution for system suitability test, and add the mobile phase to make exactly 20 mL. Confirm that the peak area of josamycin propionate obtained with 10 μ L of this solution is equivalent to 8 to 12% of that with 10 μ L of the solution for system suitability test.

System performance: Dissolve 5 mg of Josamycin Propionate and 2 mg of josamycin in 50 mL of the mobile phase. When the procedure is run with 10 μ L of this solution under the above operating conditions, josamycin and josamycin propionate are eluted in this order with the resolution between these peaks being not less than 25.

System repeatability: When the test is repeated 6 times with 10 μ L of the solution for system suitability test under the above operating conditions, the relative standard deviation of the peak area of josamycin propionate is not more than 1.5%.

Loss on drying <2.41> Not more than 1.0% (1 g, in vacuum, phosphorus (V) oxide, 60°C, 3 hours).

Residue on ignition <2.44> Not more than 0.1% (1 g).

Assay Perform the test according to the Cylinder-plate method as directed under Microbial Assay for Antibiotics <4.02> according to the following conditions.

(i) Test organism—*Bacillus subtilis* ATCC 6633

(ii) Culture medium—Use the medium ii in 3) Medium for other organisms under (1) Agar media for seed and base layer. Adjust the pH of the medium so that it will be 7.9 to 8.1 after sterilization.

(iii) Standard solutions—Weigh accurately an amount of Josamycin Propionate RS, equivalent to about 20 mg (potency), dissolve in 10 mL of methanol, add 1/15 mol/L phosphate buffer solution (pH 5.6) to make exactly 50 mL, and use this solution as the standard stock solution. Keep the standard stock solution at 5°C or below, and use within 3 days. Take exactly a suitable amount of the standard stock solution before use, add 1/15 mol/L phosphate buffer solution (pH 5.6) to make solutions so that each mL contains 80 μ g (potency) and 20 μ g (potency), and use these solutions as

the high concentration standard solution and the low concentration standard solution, respectively.

(iv) Sample solutions—Weigh accurately an amount of Josamycin Propionate, equivalent to about 20 mg (potency), dissolve in 10 mL of methanol, add 1/15 mol/L phosphate buffer solution (pH 5.6) to make exactly 50 mL. Take exactly a suitable amount of this solution, add 1/15 mol/L phosphate buffer solution (pH 5.6) to make solutions so that each mL contains 80 µg (potency) and 20 µg (potency), and use these solutions as the high concentration sample solution and the low concentration sample solution, respectively.

Containers and storage Containers—Tight containers.

Storage—Light-resistant.

Kainic Acid Hydrate

カイニン酸水和物

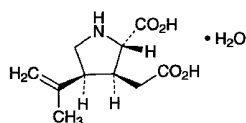

$C_{10}H_{15}NO_4 \cdot H_2O$: 231.25

(2*S*,3*S*,4*S*)-3-(Carboxymethyl)-4-(1-methylethenyl)pyrrolidine-2-carboxylic acid monohydrate

[487-79-6, anhydride]

Kainic Acid Hydrate, when dried, contains not less than 99.0% of kainic acid ($C_{10}H_{15}NO_4$: 213.23).

Description Kainic Acid Hydrate occurs as white, crystals or crystalline powder. It is odorless, and has an acid taste.

It is sparingly soluble in water and in warm water, very slightly soluble in acetic acid (100) and in ethanol (95), and practically insoluble in diethyl ether.

It dissolves in dilute hydrochloric acid and in sodium hydroxide TS.

The pH of a solution of 1.0 g of Kainic Acid Hydrate in 100 mL of water is between 2.8 and 3.5.

Melting point: about 252°C (with decomposition).

Identification (1) To 5 mL of a solution of Kainic Acid Hydrate (1 in 5000) add 1 mL of ninhydrin TS, and warm in a water bath at a temperature between 60°C and 70°C for 5 minutes: a yellow color is produced.

(2) Dissolve 50 mg of Kainic Acid Hydrate in 5 mL of acetic acid (100), and add 0.5 mL of bromine TS: the color of bromine disappears immediately.

Optical rotation <2.49> $[\alpha]_D^{20}$: $-13 - -17^\circ$ (0.5 g, water, 50 mL, 200 mm).

Purity (1) Clarity and color of solution—Dissolve 0.10 g of Kainic Acid Hydrate in 10 mL of water: the solution is clear and colorless.

(2) Chloride <1.03>—Take 0.5 g of Kainic Acid Hydrate in a platinum crucible, dissolve in 5 mL of sodium carbonate TS, and evaporate on a water bath to dryness. Heat the crucible slowly at first, and then ignite until the sample is almost incinerated. After cooling, add 12 mL of dilute nitric acid to the residue, dissolve by warming, and filter. Wash the residue with 15 mL of water, combine the washings and the filtrate, and add water to make 50 mL. Perform the test using this solution as the test solution.

Control solution: Add 5 mL of sodium carbonate TS to 0.30 mL of 0.01 mol/L hydrochloric acid VS, and proceed as

directed above (not more than 0.021%).

(3) Sulfate <1.14>—Dissolve 0.5 g of Kainic Acid Hydrate in 40 mL of water by warming. Cool, add 1 mL of dilute hydrochloric acid and water to make 50 mL, and perform the test using this solution as the test solution. Prepare the control solution with 0.30 mL of 0.005 mol/L sulfuric acid VS (not more than 0.028%).

(4) Ammonium <1.02>—Take 0.25 g of Kainic Acid Hydrate, and perform the test. Prepare the control solution with 5.0 mL of Standard Ammonium Solution (not more than 0.02%).

(5) Heavy metals <1.07>—Proceed with 1.0 g of Kainic Acid Hydrate according to Method 2, and perform the test. Prepare the control solution with 2.0 mL of Standard Lead Solution (not more than 20 ppm).

(6) Arsenic <1.11>—Dissolve 1.0 g of Kainic Acid Hydrate in 5 mL of dilute hydrochloric acid, and perform the test with this solution as the test solution (not more than 2 ppm).

(7) Amino acid and other imino acid—Dissolve 0.10 g of Kainic Acid Hydrate in 10 mL of water, and use this solution as the sample solution. Pipet 2 mL of the sample solution, and add water to make exactly 100 mL. Pipet 1 mL of this solution, add water to make exactly 20 mL, and use this solution as the standard solution. Perform the test as directed under Thin-layer Chromatography <2.03> with these solutions. Spot 10 µL each of the sample solution and standard solution on a plate of silica gel for thin-layer chromatography. Develop the plate with the supernatant liquid of a mixture of water, 1-butanol and acetic acid (100) (5:4:1) to a distance of about 10 cm, and air-dry the plate. Spray evenly a solution of ninhydrin in acetone (1 in 50) on the plate, and dry the plate at 80°C for 5 minutes: the spots other than the principal spot from the sample solution are not more intense than the spot from the standard solution.

Loss on drying <2.41> 6.5 – 8.5% (1 g, 105°C, 4 hours).

Residue on ignition <2.44> Not more than 0.1% (0.5 g).

Assay Weigh accurately about 0.4 g of Kainic Acid Hydrate, previously dried, and dissolve in 50 mL of warm water, cool and titrate <2.50> with 0.1 mol/L sodium hydroxide VS (indicator: 10 drops of bromothymol blue TS).

Each mL of 0.1 mol/L sodium hydroxide VS
= 21.32 mg of $C_{10}H_{15}NO_4$

Containers and storage Containers—Tight containers.

Kainic Acid and Santonin Powder

カイニン酸・サントニン散

Kainic Acid and Santonin Powder contains not less than 9.0% and not more than 11.0% of santonin ($C_{15}H_{18}O_3$: 246.30), and not less than 1.80% and not more than 2.20% of kainic acid hydrate ($C_{10}H_{15}NO_4 \cdot H_2O$: 231.25).

Method of preparation

Santonin	100 g
Kainic Acid Hydrate	20 g
Sarch, Lactose Hydrate or their mixture	a sufficient quantity
To make 1000 g	

Prepare as directed under Powders, with the above ingre-

dients.

Description Kainic Acid and Santonin Powder occurs as a white powder.

Identification (1) Shake 1 g of Kainic Acid and Santonin Powder with 10 mL of chloroform, and filter [use the residue for the test (2)]. Distill off the chloroform of the filtrate, and dissolve the residue in 2 mL of potassium hydroxide-ethanol TS: a red color is produced (santonin).

(2) Shake the residue obtained in (1) with 20 mL of warm water, filter, and to 1 mL of the filtrate add 10 mL of water and 1 mL of ninhydrin-L-ascorbic acid TS. Warm in a water bath between 60°C and 70°C for 5 minutes: a yellow color is produced (kainic acid).

Assay (1) Santonin—Weigh accurately about 0.25 g of Kainic Acid and Santonin Powder and about 25 mg of santonin for assay, add 20 mL each of ethanol (95), shake thoroughly for 5 minutes, and filter. Wash the residue with three 10-mL portions of ethanol (95), and filter. Combine the filtrate and the washings, and add ethanol (95) to make exactly 50 mL. Pipet 2 mL each of these solutions, add ethanol (95) to make exactly 100 mL, and use these solutions as the sample solution and the standard solution, respectively. Determine the absorbances, A_T and A_S , of the sample solution and standard solution at 240 nm as directed under Ultraviolet-visible Spectrophotometry <2.24>.

$$\begin{aligned} \text{Amount (mg) of santonin (C}_{15}\text{H}_{18}\text{O}_3) \\ = M_S \times A_T/A_S \end{aligned}$$

M_S : Amount (mg) of santonin for assay taken

(2) Kainic acid—Weigh accurately about 1.25 g of Kainic Acid and Santonin Powder, add 20 mL of diluted pyridine (1 in 10), shake thoroughly for 5 minutes, and filter. Wash the residue with three 10-mL portions of diluted pyridine (1 in 10), and filter. Combine the filtrate and the washings, and add diluted pyridine (1 in 10) to make exactly 50 mL. Pipet 2 mL of this solution, add diluted pyridine (1 in 10) to make exactly 25 mL, and use this solution as the sample solution. Separately, dissolve about 25 mg of kainic acid hydrate for assay, previously dried at 105°C for 4 hours and accurately weighed, in diluted pyridine (1 in 10) to make exactly 50 mL. Pipet 2 mL of this solution, add diluted pyridine (1 in 10) to make exactly 25 mL, and use this solution as the standard solution. Pipet 2 mL each of the sample solution and standard solution, add 2 mL of ninhydrin-L-ascorbic acid TS, and heat on a water bath for 30 minutes. After cooling immediately, shake vigorously for 2 minutes, add water to make exactly 20 mL, and allow to stand for 15 minutes. Determine the absorbances, A_T and A_S , of these solutions at 425 nm as directed under Ultraviolet-visible Spectrophotometry <2.24>, using the solution prepared in the same manner with 2 mL of diluted pyridine (1 in 10) instead of the sample solution as the blank.

$$\begin{aligned} \text{Amount (mg) of kainic acid hydrate (C}_{10}\text{H}_{15}\text{NO}_4 \cdot \text{H}_2\text{O}) \\ = M_S \times A_T/A_S \times 1.085 \end{aligned}$$

M_S : Amount (mg) of kainic acid hydrate for assay taken

Containers and storage Containers—Well-closed containers.

Storage—Light-resistant.

Kallidinogenase

カリジノゲナーゼ

[9001-01-8]

Kallidinogenase is an enzyme obtained from healthy porcine pancreas, and has kinin-releasing activity based on cleavage of kininogen.

It contains not less than 25 Kallidinogenase Units per mg. Usually, it is diluted with Lactose Hydrate or the like.

Kallidinogenase contains not less than 90% and not more than 110% of the labeled Units.

Description Kallidinogenase occurs as a white to light brown powder. It is odorless or has a faint, characteristic odor.

It is freely soluble in water, and practically insoluble in ethanol (95) and in diethyl ether.

The pH of a solution of Kallidinogenase (1 in 300) is between 5.5 and 7.5.

Identification (1) Weigh accurately an appropriate amount of Kallidinogenase according to the labeled Units, and dissolve in 0.05 mol/L phosphate buffer solution (pH 7.0) to prepare a solution containing 10 Kallidinogenase Units per mL. Pipet 5 mL of this solution, and add exactly 1 mL of trypsin inhibitor TS and 0.05 mol/L phosphate buffer solution (pH 7.0) to make exactly 10 mL. Pipet 4 mL each of this solution into two separate test tubes, add exactly 1 mL each of aprotinin TS and 0.05 mol/L phosphate buffer solution (pH 7.0) separately to each test tube, allow them to stand at room temperature for 20 minutes, and use these solutions as the sample solutions 1 and 2. Separately, pipet 1 mL of trypsin inhibitor TS, and add 0.05 mol/L phosphate buffer solution (pH 7.0) to make exactly 10 mL. Pipet 4 mL each of this solution into two separate test tubes, add exactly 1 mL each of aprotinin TS and 0.05 mol/L phosphate buffer solution (pH 7.0) separately to each tube, allow them to stand at room temperature for 20 minutes, and use these solutions as the sample solutions 3 and 4. Then, pipet 2.5 mL of substrate TS for kallidinogenase assay (1), previously warmed at $30.0 \pm 0.5^\circ\text{C}$ for 5 minutes, place in a 1-cm cell, add exactly 0.5 mL of the sample solution 1 warmed at $30.0 \pm 0.5^\circ\text{C}$ for 5 minutes, and start simultaneously a chronograph. Perform the test at $30.0 \pm 0.5^\circ\text{C}$ as directed under Ultraviolet-visible Spectrophotometry <2.24> using water as the blank, and determine the absorbances at 405 nm, A_{1-2} and A_{1-6} , of this solution, after having allowed it to stand for exactly 2 and 6 minutes. Perform the same test with the sample solutions 2, 3 and 4, and determine the absorbances, A_{2-2} , A_{2-6} , A_{3-2} , A_{3-6} , A_{4-2} and A_{4-6} , of these solutions. Calculate I by using the following equation: the value of I does not exceed 0.2.

$$I = \frac{(A_{1-6} - A_{1-2}) - (A_{3-6} - A_{3-2})}{(A_{2-6} - A_{2-2}) - (A_{4-6} - A_{4-2})}$$

(2) Pipet 2.9 mL of substrate TS for kallidinogenase assay (2), previously warmed at $30.0 \pm 0.5^\circ\text{C}$ for 5 minutes, place in a 1-cm cell, add exactly 0.1 mL of the sample solution obtained in the Assay, and start simultaneously a chronograph. Perform the test at $30.0 \pm 0.5^\circ\text{C}$ as directed under Ultraviolet-visible Spectrophotometry <2.24>, and determine the change of the absorbance at 253 nm for 4 to 6 minutes. Separately, pipet 1 mL of trypsin inhibitor TS, and add 0.05 mol/L phosphate buffer solution (pH 7.0) to make

exactly 10 mL. Add exactly 0.1 mL of this solution to exactly 2.9 mL of substrate TS for kallidinogenase assay (2), previously warmed at $30.0 \pm 0.5^\circ\text{C}$ for 5 minutes, and use this solution as the blank. If the rate of change in the absorbance remains constant, determine the change of absorbance per 1 minute, A , and calculate R by using the following equation: the value of R is between 0.12 and 0.16.

$$R = A/0.0383 \times 1/(a \times b)$$

a : Amount (mg) of Kallidinogenase in 1 mL of the sample solution

b : Amount (Unit) of kallidinogenase in 1 mg of Kallidinogenase obtained in the Assay

Specific activity Perform the test with Kallidinogenase as directed under Nitrogen Determination <1.08> to determine the nitrogen content, convert 1mg of nitrogen (N:14.01) into 6.25 mg of protein, and calculate the specific activity using the amount (Units) of Kallidinogenase obtained in the Assay: it is not less than 100 Kallidinogenase Units per 1mg of protein.

Purity (1) Fat—To 1.0 g of Kallidinogenase add 20 mL of diethyl ether, extract with occasional shaking for 30 minutes, and filter. Wash the residue with 10 mL of diethyl ether, combine the washing with the filtrate, evaporate the diethyl ether, and dry the residue at 105°C for 2 hours: the mass of the residue is not more than 1 mg.

(2) Kininase—

(i) Bradykinin solution: Weigh an appropriate amount of bradykinin, and dissolve in gelatin-phosphate buffer solution (pH 7.4) to prepare a solution containing 0.200 μg of bradykinin per mL.

(ii) Kallidinogenase solution: Weigh accurately a suitable amount of Kallidinogenase according to the labeled unit, dissolve in gelatin-phosphate buffer solution (pH 7.4) to make a solution containing 1 unit of kallidinogenase per mL.

(iii) Sample solution: Pipet 0.5 mL of bradykinin solution, warm at $30 \pm 0.5^\circ\text{C}$ for 5 minutes, then add exactly 0.5 mL of kallidinogenase solution previously warmed at $30 \pm 0.5^\circ\text{C}$ for 5 minutes, and mix immediately. After allowing this solution to stand at $30 \pm 0.5^\circ\text{C}$ for exactly 150 seconds, add exactly 0.2 mL of a solution of trichloroacetic acid (1 in 5), and shake. Boil for 3 minutes, then cool in ice immediately, centrifuge, and allow to stand at a room temperature for 15 minutes. Pipet 0.5 mL of the supernatant liquid, add exactly 0.5 mL of gelatin-tris buffer solution (pH 8.0), and shake. Pipet 0.1 mL of this solution, add exactly 0.9 mL of trichloroacetic acid-gelatin-tris buffer solution, and mix. Pipet 0.2 mL of this solution, add exactly 0.6 mL of trichloroacetic acid-gelatin-tris buffer solution, shake, and use this solution as the sample solution.

(iv) Control solution: Proceed with 0.5 mL of gelatin-phosphate buffer solution (pH 7.4) as described in (iii), and use the solution so obtained as the control solution.

(v) Procedure: Add 0.1 mL of anti-bradykinin antibody TS to goat anti-rabbit IgG antibody-coated wells of a 96-well microplate, shake, and allow to stand at a constant temperature of about 25°C for 1 hour. Remove the anti-bradykinin antibody TS, add 0.3 mL of phosphate buffer solution for microplate washing to the wells, then remove. Repeat this procedure 3 times, take off the washings thoroughly, then add 100 μL each of the sample solution and control solution, and 50 μL of gelatin-phosphate buffer solution (pH 7.0), shake, and allow to stand at a constant temperature of about 25°C for 1 hour. Then add 50 μL of peroxidase-labeled bradykinin TS, shake, and allow to stand in a cold place for a night. Take off the reaction solution, add 0.3 mL of phos-

phate buffer solution for microplate washing, and remove. Repeat this procedure more 4 times, take off the washings thoroughly, add 100 μL of substrate solution for peroxidase determination, and allow to stand at a constant temperature of about 25°C for exactly 30 minutes while protecting from light. Then add 100 μL of diluted sulfuric acid (23 in 500), shake, and determine the absorbance at 490 – 492 nm. Separately, dissolve a suitable amount of bradykinin in gelatin-phosphate buffer solution (pH 7.0) to make solutions containing exactly 100 ng, 25 ng, 6.25 ng, 1.56 ng, 0.39 ng and 0.098 ng of bradykinin per mL, and use these solutions as the standard solution (1), the standard solution (2), the standard solution (3), the standard solution (4), the standard solution (5) and the standard solution (6), respectively. Use 1 mL of gelatin-phosphate buffer solution (pH 7.0) as the standard solution (7). To each of the well add 50 μL each of the standard solutions and 100 μL of trichloroacetic acid-gelatin-tris buffer solution, and proceed in the same manner as for the sample solution and for the control solution.

Prepare the calibration curve from the amounts of bradykinin in the standard solutions and their absorbances, and calculate the amounts of bradykinin, B_T (pg) and B_S (pg), of the sample solution and the control solution.

(vi) Judgment: The value R calculated by the following equation is not less than 0.8.

$$R = B_T/B_S$$

(3) Trypsin-like substances—Pipet 4 mL of the sample stock solution prepared for the Assay, add exactly 1 mL of trypsin inhibitor TS and 0.05 mol/L phosphate buffer solution (pH 7.0) to make exactly 10 mL, and use this solution as the sample solution. Pipet 2.5 mL of substrate TS for kallidinogenase assay (1), previously warmed at $30 \pm 0.5^\circ\text{C}$ for 5 minutes, place in a 1-cm cell, add exactly 0.5 mL of the sample solution, warmed at $30 \pm 0.5^\circ\text{C}$ for 5 minutes, and start simultaneously a chronograph. Perform the test at $30 \pm 0.5^\circ\text{C}$ as directed under Ultraviolet-visible Spectrophotometry <2.24> using water as the blank, and determine the absorbances at 405 nm, A_2 and A_6 , of this solution after having allowed it to stand for exactly 2 and 6 minutes. Separately, pipet 4 mL of the sample stock solution prepared for the Assay, add 0.05 mol/L phosphate buffer solution (pH 7.0) to make exactly 10 mL, and use this solution as the control solution. Perform the same test with the control solution, and determine the absorbances, A'_2 and A'_6 . Calculate T by using the following equation: the value of T does not exceed 0.05.

$$T = \{(A'_6 - A'_2) - (A_6 - A_2)\}/(A'_6 - A'_2)$$

(4) Protease—Weigh accurately an appropriate amount of Kallidinogenase according to the labeled Units, dissolve in 0.05 mol/L phosphate buffer solution (pH 7.0) to prepare a solution containing 1 Kallidinogenase Unit per mL, and use this solution as the sample solution. Pipet 1 mL of the sample solution, place in a test tube, and allow to stand at $35 \pm 0.5^\circ\text{C}$ for 5 minutes. Then, pipet 5 mL of substrate TS for kallidinogenase assay (3), previously warmed to $35 \pm 0.5^\circ\text{C}$, add quickly to the sample solution in the test tube, and allow to stand at $35 \pm 0.5^\circ\text{C}$ for exactly 20 minutes. Then add exactly 5 mL of trichloroacetic acid TS, shake well, allow to stand at room temperature for 1 hour, and filter through a membrane filter (5 μm in pore size). Discard the first 3 mL of the filtrate, and determine the absorbance, A , of the subsequent filtrate at 280 nm within 2 hours as directed under Ultraviolet-visible Spectrophotometry <2.24>, using water as the blank. Separately, pipet 1 mL of the sample solution, add exactly 5 mL of trichloroacetic acid TS, shake well, and

add exactly 5 mL of the substrate TS for kallidinogenase assay (3). Proceed in the same manner as described for the sample solution, and determine the absorbance, A_0 , of this solution. Calculate the value of $(A - A_0)$: it is not more than 0.2.

Loss on drying <2.41> Not more than 2.0% (0.5 g, in vacuum, phosphorus (V) oxide, 4 hours).

Residue on ignition <2.44> Not more than 3% (0.5 g, 650 – 750°C).

Kinin-releasing activity

(i) Kallidinogenase solution: Weigh accurately a suitable amount of Kallidinogenase, according to the labeled unit, dissolve in 0.02 mol/L phosphate buffer solution (pH 8.0) to make a solution containing 0.1 unit of kallidinogenase per mL. Perform this procedure by using glassware.

(ii) Sample solution: Pipet 0.5 mL of kininogen TS, warm at $30 \pm 0.5^\circ\text{C}$ for 5 minutes, then add exactly 0.5 mL of kallidinogenase solution previously warmed at $30 \pm 0.5^\circ\text{C}$ for 5 minutes, and mix immediately. After allow this solution to stand at $30 \pm 0.5^\circ\text{C}$ for exactly 2 minutes, add exactly 0.2 mL of a solution of trichloroacetic acid (1 in 5), and shake. Boil for 3 minutes, then cool in ice immediately, centrifuge, and allow to stand at a room temperature for 15 minutes. Pipet 0.5 mL of the supernatant liquid, add exactly 0.5 mL of gelatin-tris buffer solution (pH 8.0), and shake. Pipet 0.1 mL of this solution, add exactly 1.9 mL of trichloroacetic acid-gelatin-tris buffer solution, shake, and use this solution as the sample solution.

(iii) Procedure: Perform the test with the sample solution as directed in the Purity (2), and determine the amount, B (pg), of kinin per well. The kinin-releasing activity per 1 unit of Kallidinogenase calculated by the following equation is not less than 500 ng bradykinin equivalent/minute/unit.

Kinin-releasing activity (ng bradykinin equivalent/minute/unit) per 1 unit of Kallidinogenase = $B \times 4.8$

Assay Weigh accurately an appropriate amount of Kallidinogenase according to the labeled Units, dissolve in 0.05 mol/L phosphate buffer solution (pH 7.0) to prepare a solution containing about 10 Kallidinogenase Units per mL, and use this solution as the sample stock solution. Pipet 4 mL of the sample stock solution, add exactly 1 mL of trypsin inhibitor TS and 0.05 mol/L phosphate buffer solution (pH 7.0) to make exactly 10 mL, and use this solution as the sample solution. Pipet 2.5 mL of substrate TS for kallidinogenase assay (1), previously warmed at $30 \pm 0.5^\circ\text{C}$ for 5 minutes, place in a 1-cm cell, add exactly 0.5 mL of the sample solution, warmed at $30 \pm 0.5^\circ\text{C}$ for 5 minutes, and start simultaneously a chronograph. Perform the test at $30 \pm 0.5^\circ\text{C}$ as directed under the Ultraviolet-visible Spectrophotometry <2.24> using water as the blank, and determine the absorbances at 405 nm, A_{T2} and A_{T6} , of this solution after allowing to stand for exactly 2 and 6 minutes. Separately, dissolve Kallidinogenase RS in 0.05 mol/L phosphate buffer solution (pH 7.0) to make a solution so that each mL contains exactly 10 Units, and use this solution as the standard stock solution. Pipet 4 mL of the stock solution, add exactly 1 mL of trypsin inhibitor TS and 0.05 mol/L phosphate buffer solution (pH 7.0) to make exactly 10 mL, and use this solution as the standard solution. Take exactly 0.5 mL of the standard solution, perform the test in the same manner as described for the sample solution, and determine the absorbances, A_{S2} and A_{S6} , of the solution after allowing to stand for exactly 2 and 6 minutes. Separately, take exactly 1 mL of the trypsin inhibitor TS, and add 0.05 mol/L phosphate

buffer solution (pH 7.0) to make exactly 10 mL. Pipet 0.5 mL of this solution, perform the test in the same manner as described for the sample solution, and determine the absorbances, A_{O2} and A_{O6} , of the solution after allowing to stand for exactly 2 and 6 minutes.

Units per 1 mg of Kallidinogenase

$$= \frac{(A_{T6} - A_{T2}) - (A_{O6} - A_{O2})}{(A_{S6} - A_{S2}) - (A_{O6} - A_{O2})} \times \frac{M_S}{a} \times \frac{1}{b}$$

M_S : Amount (Units) of Kallidinogenase RS taken

a : Volume (mL) of the standard stock solution

b : Amount (mg) of Kallidinogenase in 1 mL of the sample stock solution

Containers and storage Containers—Tight containers.

Kanamycin Monosulfate

カナマイシン—硫酸塩

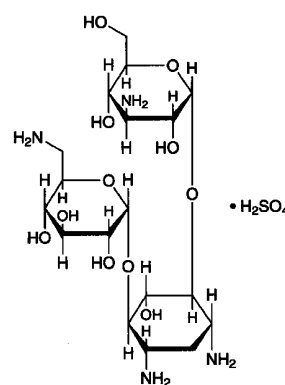

$\text{C}_{18}\text{H}_{36}\text{N}_4\text{O}_{11} \cdot \text{H}_2\text{SO}_4$: 582.58

3-Amino-3-deoxy- α -D-glucopyranosyl-(1 \rightarrow 6)-
[6-amino-6-deoxy- α -D-glucopyranosyl-(1 \rightarrow 4)]-2-deoxy-
D-streptamine monosulfate
[25389-94-0]

Kanamycin Monosulfate is the sulfate of an aminoglycoside substance having antibacterial activity produced by the growth of *Streptomyces kanamyceticus*.

It contains not less than 750 μg (potency) and not more than 832 μg (potency) per mg, calculated on the dried basis. The potency of Kanamycin Monosulfate is expressed as mass (potency) of kanamycin ($\text{C}_{18}\text{H}_{36}\text{N}_4\text{O}_{11}$: 484.50).

Description Kanamycin Monosulfate occurs as a white crystalline powder.

It is freely soluble in water, and practically insoluble in ethanol (99.5).

Identification (1) Dissolve 50 mg of Kanamycin Monosulfate in 3 mL of water, and add 6 mL of anthrone TS: a blue-purple color develops.

(2) Dissolve 20 mg each of Kanamycin Monosulfate and Kanamycin Monosulfate RS in 1 mL of water, and use these solutions as the sample solution and standard solution. Perform the test with these solutions as directed under Thin-layer Chromatography <2.03>. Spot 5 μL each of the sample solution and standard solution on a plate of silica gel for thin-layer chromatography. Develop the plate with the supernatant layer of a mixture of chloroform, ammonia solution (28) and methanol (2:1:1) to a distance of about 10 cm, and air-dry the plate. Spray evenly a solution of 0.2% nin-

hydrin-water saturated 1-butanol TS on the plate, and heat the plate at 100°C for 10 minutes: the principal spot obtained from the sample solution and the spot from the standard solution show a purple-brown color and the same *R_f* value.

(3) To a solution of Kanamycin Monosulfate (1 in 5) add 1 drop of barium chloride TS: a white precipitate is formed.

Optical rotation <2.49> $[\alpha]_D^{20}$: +112 – +123° (0.2 g calculated on the dried basis, water, 20 mL, 100 mm).

Sulfuric acid Weigh accurately about 0.25 g of Kanamycin Monosulfate, dissolve in 100 mL of water, adjust the pH to 11.0 with ammonia solution (28), add exactly 10 mL of 0.1 mol/L barium chloride VS, and titrate <2.50> with 0.1 mol/L disodium dihydrogen ethylenediamine tetraacetate VS until the color of the solution, blue-purple, disappears (indicator: 0.5 mg of phthalein purple). At a near of the end-point add 50 mL of ethanol (99.5). Perform a blank determination in the same manner. The amount of sulfuric acid (SO₄) is not less than 15.0% and not more than 17.0%, calculated on the dried basis.

Each mL of 0.1 mol/L barium chloride VS
= 9.606 mg of SO₄

Purity (1) Heavy metals <1.07>—Proceed with 2.0 g of Kanamycin Monosulfate according to Method 4, and perform the test. Prepare the control solution with 2.0 mL of Standard Lead Solution (not more than 10 ppm).

(2) Arsenic <1.11>—Prepare the test solution with 2.0 g of Kanamycin Monosulfate according to Method 4, and perform the test (not more than 1 ppm).

(3) Related substances—Dissolve 0.30 g of Kanamycin Monosulfate in water to make exactly 10 mL, and use this solution as the sample solution. Separately, dissolve 45 mg of Kanamycin Monosulfate RS in water to make exactly 50 mL, and use this solution as the standard solution. Perform the test with these solutions as directed under Thin-layer Chromatography <2.03>. Spot 1 μL each of the sample solution and standard solution on a plate of silica gel for thin-layer chromatography. Develop the plate with a solution of potassium dihydrogen phosphate (3 in 40) to a distance of about 10 cm, and air-dry the plate. Spray evenly a solution of ninhydrin in 1-butanol (1 in 100) on the plate, and heat the plate at 110°C for 10 minutes: the spot other than the principal spot obtained from the sample solution is not more intense than the spot from the standard solution.

Loss on drying <2.41> Not more than 4.0% (5 g, reduced pressure not exceeding 0.67 kPa, 60°C, 3 hours).

Residue on ignition <2.44> Not more than 0.5% (1 g).

Assay Perform the test according to the Cylinder-plate method as directed under Microbial Assay for Antibiotics <4.02> according to the following conditions.

(i) Test organism—*Bacillus subtilis* ATCC 6633

(ii) Culture medium—Use the medium i in 1) under (1) Agar media for seed and base layer.

(iii) Standard solutions—Weigh accurately an amount of Kanamycin Monosulfate RS, previously dried, equivalent to about 20 mg (potency), dissolve in diluted phosphate buffer solution (pH 6.0) (1 in 2) to make exactly 50 mL, and use this solution as the standard stock solution. Keep the standard stock solution between 5 and 15°C and use within 30 days. Take exactly a suitable amount of the standard stock solution before use, add 0.1 mol/L phosphate buffer solution (pH 8.0) to make solutions so that each mL contains 20 μg (potency) and 5 μg (potency), and use these solutions as

the high concentration standard solution and the low concentration standard solution, respectively.

(iv) Sample solutions—Weigh accurately an amount of Kanamycin Monosulfate, equivalent to about 20 mg (potency), and dissolve in water to make exactly 50 mL. Take exactly a suitable amount of this solution, add 0.1 mol/L phosphate buffer solution (pH 8.0) to make solutions so that each mL contains 20 μg (potency) and 5 μg (potency), and use these solutions as the high concentration sample solution and the low concentration sample solution, respectively.

Containers and storage Containers—Well-closed containers.

Kanamycin Sulfate

カナマイシン硫酸塩

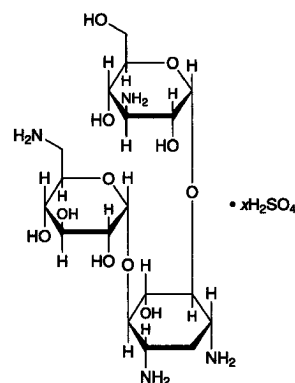

C₁₈H₃₆N₄O₁₁·xH₂SO₄

3-Amino-3-deoxy-α-D-glucopyranosyl-(1→6)-
[6-amino-6-deoxy-α-D-glucopyranosyl-(1→4)]-2-deoxy-
D-streptamine sulfate
[133-92-6]

Kanamycin Sulfate is the sulfate of an aminoglycoside substance having antibacterial activity produced by the growth of *Streptomyces kanamyceticus*.

It contains not less than 690 μg (potency) and not more than 740 μg (potency) per mg, calculated on the dried basis. The potency of Kanamycin Sulfate is expressed as mass (potency) of kanamycin (C₁₈H₃₆N₄O₁₁: 484.50).

Description Kanamycin Sulfate occurs as a white to yellow-white powder.

It is very soluble in water, and practically insoluble in ethanol (99.5).

Identification (1) Dissolve 20 mg each of Kanamycin Sulfate and Kanamycin Monosulfate RS in 1 mL of water, and use these solutions as the sample solution and standard solution. Perform the test with these solutions as directed under Thin-layer Chromatography <2.03>. Spot 5 μL each of the sample solution and standard solution on a plate of silica gel for thin-layer chromatography. Develop the plate with a mixture of chloroform, ammonia solution (28) and methanol (2:1:1) to a distance of about 10 cm, and air-dry the plate. Spray evenly 0.2% ninhydrin-water saturated 1-butanol TS on the plate, and heat the plate at 100°C for 10 minutes: the principal spot obtained from the sample solution and the spot from the standard solution show a purple-brown color and the same *R_f* value.

(2) A solution of Kanamycin Sulfate (1 in 10) responds

to Qualitative Test <1.09> (1) for sulfate.

Optical rotation <2.49> $[\alpha]_D^{20}$: +103 – +115° (0.5 g calculated on the dried basis, water, 50 mL, 100 mm).

pH <2.54> The pH of a solution obtained by dissolving 1.0 g of Kanamycin Sulfate in 20 mL of water is between 6.0 and 7.5.

Purity (1) Clarity and color of solution—Dissolve 1.5 g of Kanamycin Sulfate in 5 mL of water: the solution is clear. Determine the absorbance of this solution at 400 nm as directed under Ultraviolet-visible Spectrophotometry <2.24>: not more than 0.15.

(2) Heavy metals <1.07>—Proceed with 1.0 g of Kanamycin Sulfate according to Method 4, and perform the test. Prepare the control solution with 3.0 mL of Standard Lead Solution (not more than 30 ppm).

(3) Arsenic <1.11>—Prepare the test solution with 2.0 g of Kanamycin Sulfate according to Method 3, and perform the test (not more than 1 ppm).

(4) Related substances—Dissolve 0.30 g of Kanamycin Sulfate in water to make exactly 10 mL, and use this solution as the sample solution. Separately, dissolve 9.0 mg of Kanamycin Monosulfate RS in water to make exactly 10 mL, and use this solution as the standard solution. Perform the test with these solutions as directed under Thin-layer Chromatography <2.03>. Spot 1 μ L each of the sample solution and standard solution on a plate of silica gel for thin-layer chromatography. Develop the plate with a solution of potassium dihydrogen phosphate (3 in 40) to a distance of about 10 cm, and air-dry the plate. Spray evenly a solution of ninhydrin in 1-butanol (1 in 100) on the plate, and heat the plate at 110°C for 10 minutes: the spot other than the principal spot obtained from the sample solution is not more intense than the spot from the standard solution.

Loss on drying <2.41> Not more than 5.0% (0.5 g, reduced pressure not exceeding 0.67 kPa, 60°C, 3 hours).

Assay Perform the test according to the Cylinder-plate method as directed under Microbial Assay for Antibiotics <4.02> according to the following conditions.

(i) Test organism—*Bacillus subtilis* ATCC 6633

(ii) Culture medium—Use the medium i in 1) under (1) Agar media for seed and base layer having pH 7.8 to 8.0 after sterilization.

(iii) Standard solutions—Weigh accurately an amount of Kanamycin Monosulfate RS, previously dried, equivalent to about 20 mg (potency), dissolve in diluted phosphate buffer solution (pH 6.0) (1 in 2) to make exactly 50 mL, and use this solution as the standard stock solution. Keep the standard stock solution at 5 to 15°C and use within 30 days. Take exactly a suitable amount of the standard stock solution before use, add 0.1 mol/L phosphate buffer solution (pH 8.0) to make solutions so that each mL contains 20 μ g (potency) and 5 μ g (potency), and use these solutions as the high concentration standard solution and the low concentration standard solution, respectively.

(iv) Sample solutions—Weigh accurately an amount of Kanamycin Sulfate, equivalent to about 20 mg (potency), and dissolve in water to make exactly 50 mL. Take exactly a suitable amount of this solution, add 0.1 mol/L phosphate buffer solution (pH 8.0) to make solutions so that each mL contains 20 μ g (potency) and 5 μ g (potency), and use these solutions as the high concentration sample solution and the low concentration sample solution, respectively.

Containers and storage Containers—Tight containers.

Kaolin

カオリン

Kaolin is a native, hydrous aluminum silicate.

Description Kaolin occurs as white or nearly white, fragmentary masses or powder. It has a slightly clay-like odor.

It is practically insoluble in water, in ethanol (99.5) and in diethyl ether.

It is insoluble in dilute hydrochloric acid and in sodium hydroxide TS.

When moistened with water, it darkens and becomes plastic.

Identification (1) Heat 1 g of Kaolin with 10 mL of water and 5 mL of sulfuric acid in a porcelain dish, and evaporate the mixture nearly to dryness. Cool, add 20 mL of water, boil for 2 to 3 minutes, and filter: the color of the residue is gray.

(2) The filtrate obtained in (1) responds to Qualitative Tests <1.09> (1), (2) and (4) for aluminum salt.

Purity (1) Acid or alkali—Add 25 mL of water to 1.0 g of Kaolin, agitate thoroughly, and filter: the pH <2.54> of the filtrate is between 4.0 and 7.5.

(2) Acid-soluble substances—Add 20 mL of dilute hydrochloric acid to 1.0 g of Kaolin, agitate for 15 minutes, and filter. Evaporate 10 mL of the filtrate to dryness, and heat strongly between 450°C and 550°C to constant mass: the mass of the ignited residue is not more than 10 mg.

(3) Carbonate—Stir 1.0 g of Kaolin with 5 mL of water, then add 10 mL of diluted sulfuric acid (1 in 2): no effervescence occurs.

(4) Heavy metals <1.07>—Boil 1.5 g of Kaolin gently with 50 mL of water and 5 mL of hydrochloric acid for 20 minutes with frequent agitation, cool, centrifuge, and separate the supernatant liquid. Wash the precipitate twice with 10 mL of water, centrifuge each time, and combine the supernatant liquid and the washings. Add dropwise ammonia solution (28) to this solution until a slight precipitate occurs, then add dilute hydrochloric acid dropwise while agitating strongly to complete solution. Add 0.45 g of hydroxylammonium chloride, and heat. Cool, add 0.45 g of sodium acetate trihydrate and 6 mL of dilute acetic acid, filter if necessary, and wash with 10 mL of water. Combine the filtrate and the washings, and add water to make 150 mL. Perform the test using 50 mL of this solution as the test solution. To 2.5 mL of Standard Lead Solution add 0.15 g of hydroxylammonium chloride, 0.15 g of sodium acetate trihydrate, 2 mL of dilute acetic acid and water to make 50 mL, and use this solution as the control solution (not more than 50 ppm).

(5) Iron <1.10>—Add 10 mL of dilute hydrochloric acid to 40 mg of Kaolin, and heat for 10 minutes with shaking in a water bath. After cooling, add 0.5 g of L-tartaric acid, dissolve with shaking, prepare the test solution with this solution according to Method 2, and perform the test according to Method B. Prepare the control solution with 2.0 mL of Standard Iron Solution (not more than 500 ppm).

(6) Arsenic <1.11>—Add 5 mL of water and 1 mL of sulfuric acid to 1.0 g of Kaolin, and heat on a sand bath until white fumes begin to evolve. Cool, and add water to make 5 mL. Perform the test with this solution as the test solution (not more than 2 ppm).

(7) Foreign matter—Place 5 g of Kaolin in a beaker, add 100 mL of water, stir, and decant to leave sand. Repeat this procedure several times with 100-mL portions of water: no

sandy residue remains.

Loss on ignition <2.43> Not more than 15.0% (1 g, 600°C, 5 hours).

Plasticity Add 7.5 mL of water to 5.0 g of Kaolin, and agitate thoroughly: the resultant mass has no remarkable fluidity.

Containers and storage Containers—Well-closed containers.

Ketamine Hydrochloride

ケタミン塩酸塩

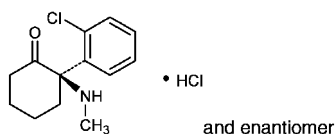

$C_{13}H_{16}ClNO.HCl$: 274.19
(2*RS*)-2-(2-Chlorophenyl)-2-(methylamino)cyclohexanone monohydrochloride
[1867-66-9]

Ketamine Hydrochloride, when dried, contains not less than 99.0% of ketamine hydrochloride ($C_{13}H_{16}ClNO.HCl$).

Description Ketamine Hydrochloride occurs as white, crystals or crystalline powder.

It is very soluble in formic acid, freely soluble in water and in methanol, sparingly soluble in ethanol (95) and in acetic acid (100), and practically insoluble in acetic anhydride and in diethyl ether.

A solution of Ketamine Hydrochloride (1 in 10) shows no optical rotation.

Melting point: about 258°C (with decomposition).

Identification (1) Determine the absorption spectrum of a solution of Ketamine Hydrochloride in 0.1 mol/L hydrochloric acid TS (1 in 3000) as directed under Ultraviolet-visible Spectrophotometry <2.24>, and compare the spectrum with the Reference Spectrum: both spectra exhibit similar intensities of absorption at the same wavelengths.

(2) Determine the infrared absorption spectrum of Ketamine Hydrochloride, previously dried, as directed in the potassium bromide disk method under Infrared Spectrophotometry <2.25>, and compare the spectrum with the Reference Spectrum: both spectra exhibit similar intensities of absorption at the same wave numbers.

(3) A solution of Ketamine Hydrochloride (1 in 10) responds to Qualitative Tests <1.09> (2) for chloride.

Absorbance <2.24> $E_{1\text{cm}}^{1\%}$ (269 nm): 22.0–24.5 (after drying, 30 mg, 0.1 mol/L hydrochloric acid TS, 100 mL).

pH <2.54> Dissolve 1.0 g of Ketamine Hydrochloride in 10 mL of freshly boiled and cooled water: the pH of the solution is between 3.5 and 4.5.

Purity (1) Clarity and color of solution—Dissolve 1.0 g of Ketamine Hydrochloride in 5 mL of water: the solution is clear and colorless.

(2) Heavy metals <1.07>—Proceed with 1.0 g of Ketamine Hydrochloride according to Method 1, and perform the test. Prepare the control solution with 2.0 mL of Standard Lead Solution (not more than 20 ppm).

(3) Arsenic <1.11>—Prepare the test solution with 1.0 g of Ketamine Hydrochloride, according to Method 1, and perform the test (not more than 2 ppm).

(4) Related substances—Dissolve 0.5 g of Ketamine Hydrochloride in 10 mL of methanol and use this solution as the sample solution. Pipet 1 mL of the sample solution, add methanol to make exactly 200 mL, and use this solution as the standard solution. Perform the test with these solutions as directed under Thin-layer Chromatography <2.03>. Spot 2 μL each of the sample solution and standard solution on a plate of silica gel for thin-layer chromatography. Develop the plate with a mixture of cyclohexane and isopropylamine (49:1) to a distance of about 10 cm, and air-dry the plate. Spray evenly Dragendorff's TS for spraying on the plate, dry the plate, and then spray evenly hydrogen peroxide TS: the spots other than the principal spot obtained from the sample solution is not more intense than the spot from the standard solution.

Loss on drying <2.41> Not more than 0.5% (1 g, 105°C, 3 hours).

Residue on ignition <2.44> Not more than 0.1% (1 g).

Assay Weigh accurately about 0.5 g of Ketamine Hydrochloride, previously dried, dissolve in 1 mL of formic acid, add 70 mL of a mixture of acetic anhydride and acetic acid (100) (6:1), and titrate <2.50> with 0.1 mol/L perchloric acid VS (potentiometric titration). Perform a blank determination in the same manner, and make any necessary correction.

Each mL of 0.1 mol/L perchloric acid VS
= 27.42 mg of $C_{13}H_{16}ClNO.HCl$

Containers and storage Containers—Tight containers.

Ketoconazole

ケトコナゾール

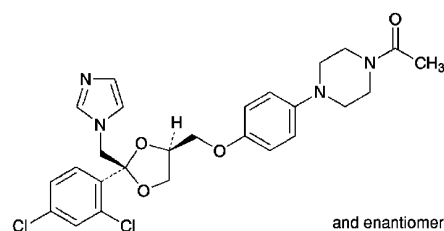

$C_{26}H_{28}Cl_2N_4O_4$: 531.43
1-Acetyl-4-(4-[(2*RS*,4*SR*)-2-(2,4-dichlorophenyl)-2-(1*H*-imidazol-1-ylmethyl)-1,3-dioxolan-4-yl]methoxy)phenyl)piperazine
[65277-42-1]

Ketoconazole, when dried, contains not less than 99.0% and not more than 101.0% of ketoconazole ($C_{26}H_{28}Cl_2N_4O_4$).

Description Ketoconazole occurs as a white to light yellow-white powder.

It is soluble in methanol, sparingly soluble in ethanol (99.5), and practically insoluble in water.

A solution of Ketoconazole in methanol (1 in 20) shows no optical rotation.

Identification (1) Determine the absorption spectrum of a solution of Ketoconazole in methanol (3 in 100,000) as directed under Ultraviolet-visible Spectrophotometry <2.24>, and compare the spectrum with the Reference Spectrum:

both spectra exhibit similar intensities of absorption at the same wavelengths.

(2) Determine the infrared absorption spectrum of Ketoconazole as directed in the potassium bromide disk method under Infrared Spectrophotometry <2.25>, and compare the spectrum with the Reference Spectrum: both spectra exhibit similar intensities of absorption at the same wave numbers.

(3) Perform the test with Ketoconazole as directed under Flame Coloration Test <1.04> (2): a green color appears.

Melting point <2.60> 148 – 152°C

Purity (1) Heavy metals <1.07>—Proceed with 1.0 g of Ketoconazole according to Method 2, and perform the test. Prepare the control solution with 1.0 mL of Standard Lead Solution (not more than 10 ppm).

(2) Related Substances—Dissolve 0.10 g of Ketoconazole in 10 mL of methanol, and use this solution as the sample solution. Pipet 5 mL of the sample solution, and add methanol to make exactly 100 mL. Pipet 1 mL of this solution, add methanol to make exactly 10 mL, and use this solution as the standard solution. Perform the test with exactly 10 μ L each of the sample solution and standard solution as directed under Liquid Chromatography <2.01> according to the following conditions. Determine each peak area of both solutions by the automatic integration method: the area of the peak other than ketoconazole obtained from the sample solution is not larger than 2/5 times the peak area of ketoconazole from the standard solution, and the total area of the peaks other than ketoconazole from the sample solution is not larger than the peak area of ketoconazole from the standard solution.

Operating conditions—

Detector: An ultraviolet absorption photometer (wavelength: 220 nm).

Column: A stainless steel column 4.6 mm in inside diameter and 10 cm in length, packed with octadecylsilanized silica gel for liquid chromatography (3 μ m in particle diameter).

Column temperature: A constant temperature of about 25°C.

Mobile phase A: Acetonitrile for liquid chromatography.

Mobile phase B: A solution of tetrabutylammonium hydrogensulfate (17 in 5000).

Flowing of mobile phase: Control the gradient by mixing the mobile phases A and B as directed in the following table.

Time after injection of sample (min)	Mobile phase A (vol%)	Mobile phase B (vol%)
0 – 10	5 → 50	95 → 50
10 – 15	50	50

Flow rate: 2.0 mL per minute.

Time span of measurement: For 15 minutes after injection, beginning after the solvent peak.

System suitability—

Test for required detectability: Pipet 2 mL of the standard solution, and add methanol to make exactly 20 mL. Confirm that the peak area of ketoconazole obtained with 10 μ L of this solution is equivalent to 7 to 13% of that with 10 μ L of the standard solution.

System performance: When the procedure is run with 10 μ L of the standard solution under the above operating conditions, the number of theoretical plates and the symmetry factor of the peak of ketoconazole are not less than 40,000 and not more than 1.5, respectively.

System repeatability: When the test is repeated 6 times with 10 μ L of the standard solution under the above operating conditions, the relative standard deviation of the peak area of ketoconazole is not more than 2.5%.

Loss on drying <2.41> Not more than 0.5% (1 g, 105°C, 4 hours).

Residue on ignition <2.44> Not more than 0.1% (1 g).

Assay Weigh accurately about 0.2 g of Ketoconazole, previously dried, dissolve in 70 mL of a mixture of 2-butanone and acetic acid (100) (7:1), and titrate <2.50> with 0.1 mol/L perchloric acid VS (potentiometric titration). Perform a blank determination in the same manner, and make any necessary correction.

Each mL of 0.1 mol/L perchloric acid VS
= 26.57 mg of C₂₆H₂₈Cl₂N₄O₄

Containers and storage Containers—Tight containers.

Storage—Light-resistant.

Ketoconazole Cream

ケトコナゾールクリーム

Ketoconazole Cream contains not less than 95.0% and not more than 105.0% of the labeled amount of ketoconazole (C₂₆H₂₈Cl₂N₄O₄; 531.43).

Method of preparation Prepare as directed under Creams, with Ketoconazole.

Identification To a quantity of Ketoconazole Cream, equivalent to 0.1 g of Ketoconazole, add 20 mL of 2-propanol, shake for 20 minutes, centrifuge, and use the supernatant liquid as the sample solution. Separately, dissolve 25 mg of ketoconazole in 5 mL of 2-propanol, and use this solution as the standard solution. Perform the test with these solutions as directed under Thin-layer Chromatography <2.03>. Spot 5 μ L each of the sample solution and standard solution on a plate of silica gel with fluorescent indicator for thin-layer chromatography. Develop the plate with a mixture of ethyl acetate, hexane, methanol, water and ammonia solution (28) (40:40:25:2:1) to a distance of about 12 cm, and air-dry the plate. Examine under ultraviolet light (main wavelength: 254 nm): the principal spot obtained from the sample solution has the same R_f value as the spot from the standard solution.

Assay Weigh accurately an amount of Ketoconazole Cream, equivalent to about 25 mg of ketoconazole (C₂₆H₂₈Cl₂N₄O₄), dissolve in methanol to make exactly 100 mL. Pipet 10 mL of this solution, add exactly 4 mL of the internal standard solution, add methanol to make 50 mL, and use this solution as the sample solution. Separately, weigh accurately about 25 mg of ketoconazole for assay, previously dried at 105°C for 4 hours, and dissolve in methanol to make exactly 50 mL. Pipet 5 mL of this solution, add exactly 4 mL of the internal standard solution, add methanol to make 50 mL, and use this solution as the standard solution. Perform the test with 10 μ L each of the sample solution and standard solution as directed under Liquid Chromatography <2.01> according to the following conditions, and calculate the ratios, Q_T and Q_S, of the peak area of ketoconazole to that of the internal standard.

Amount (mg) of ketoconazole (C₂₆H₂₈Cl₂N₄O₄)
= M_S × Q_T/Q_S

M_S : Amount (mg) of ketoconazole for assay taken

Internal standard solution—A solution of xanthone in methanol (1 in 10,000).

Operating conditions—

Detector: An ultraviolet absorption photometer (wavelength: 230 nm).

Column: A stainless steel column 4.6 mm in inside diameter and 15 cm in length, packed with octadecylsilanized silica gel for liquid chromatography (5 μ m in particle diameter).

Column temperature: A constant temperature of about 40°C.

Mobile phase: To ammonium acetate solution (1 in 200) add acetic acid (100) to adjust the pH to 5.0. To 250 mL of this solution add 750 mL of methanol.

Flow rate: Adjust so that the retention time of ketoconazole is about 8 minutes.

System suitability—

System performance: When the procedure is run with 10 μ L of the standard solution under the above operating conditions, the internal standard and ketoconazole are eluted in this order with the resolution between these peaks being not less than 5.

System repeatability: When the test is repeated 6 times with 10 μ L of the standard solution under the above operating conditions, the relative standard deviation of the ratio of the peak area of ketoconazole to that of the internal standard is not more than 1.0%.

Containers and storage Containers—Tight containers.

Ketoconazole Lotion

ケトコナゾールローション

Ketoconazole Lotion is an emulsion lotion.

It contains not less than 93.0% and not more than 107.0% of the labeled amount of ketoconazole ($C_{26}H_{28}Cl_2N_4O_4$: 531.43).

Method of preparation Prepare as directed under Lotions, with Ketoconazole.

Description Ketoconazole Lotion occurs as a white emulsion.

Identification Shake well and take an amount of Ketoconazole Lotion, equivalent to 0.1 g of Ketoconazole, add 20 mL of 2-propanol, shake for 20 minutes, centrifuge, and use the supernatant liquid as the sample solution. Separately, dissolve 25 mg of ketoconazole in 5 mL of 2-propanol, and use this solution as the standard solution. Perform the test with these solutions as directed under Thin-layer Chromatography <2.03>. Spot 5 μ L each of the sample solution and standard solution on a plate of silica gel with fluorescent indicator for thin-layer chromatography. Develop the plate with a mixture of ethyl acetate, hexane, methanol, water and ammonia solution (28) (40:40:25:2:1) to a distance of about 12 cm, and air-dry the plate. Examine under ultraviolet light (main wavelength: 254 nm): the principal spot obtained from the sample solution has the same R_f value as the spot from the standard solution.

Assay Shake well and weigh accurately an amount of Ketoconazole Lotion, equivalent to about 25 mg of ketoconazole ($C_{26}H_{28}Cl_2N_4O_4$), dissolve in methanol to make exactly 100 mL. Pipet 10 mL of this solution, add exactly 4 mL of the internal standard solution, add methanol to make 50 mL,

and use this solution as the sample solution. Separately, weigh accurately about 25 mg of ketoconazole for assay, previously dried at 105°C for 4 hours, dissolve in methanol to make exactly 50 mL. Pipet 5 mL of this solution, add exactly 4 mL of the internal standard solution, add methanol to make 50 mL, and use this solution as the standard solution. Perform the test with 10 μ L each of the sample solution and standard solution as directed under Liquid Chromatography <2.01> according to the following conditions, and calculate the ratios, Q_T and Q_S , of the peak area of ketoconazole to that of the internal standard.

$$\begin{aligned} &\text{Amount (mg) of ketoconazole (C}_{26}\text{H}_{28}\text{Cl}_2\text{N}_4\text{O}_4) \\ &= M_S \times Q_T/Q_S \end{aligned}$$

M_S : Amount (mg) of ketoconazole for assay taken

Internal standard solution—A solution of xanthone in methanol (1 in 10,000).

Operating conditions—

Detector: An ultraviolet absorption photometer (wavelength: 230 nm).

Column: A stainless steel column 4.6 mm in inside diameter and 15 cm in length, packed with octadecylsilanized silica gel for liquid chromatography (5 μ m in particle diameter).

Column temperature: A constant temperature of about 40°C.

Mobile phase: To ammonium acetate solution (1 in 200) add acetic acid (100) to adjust the pH to 5.0. To 250 mL of this solution add 750 mL of methanol.

Flow rate: Adjust so that the retention time of ketoconazole is about 8 minutes.

System suitability—

System performance: When the procedure is run with 10 μ L of the standard solution under the above operating conditions, the internal standard and ketoconazole are eluted in this order with the resolution between these peaks being not less than 5.

System repeatability: When the test is repeated 6 times with 10 μ L of the standard solution under the above operating conditions, the relative standard deviation of the ratio of the peak area of ketoconazole to that of the internal standard is not more than 1.0%.

Containers and storage Containers—Tight containers.

Ketoconazole Solution

ケトコナゾール液

Ketoconazole Solution is a liquid for external use.

Ketoconazole Solution contains not less than 95.0% and not more than 105.0% of the labeled amount of ketoconazole ($C_{26}H_{28}Cl_2N_4O_4$: 531.43).

Method of preparation Prepare as directed under Liquids and Solutions for Cutaneous Application, with Ketoconazole.

Description Ketoconazole Solution is a clear liquid.

Identification To a volume of Ketoconazole Solution, equivalent to 10 mg of Ketoconazole, add methanol to make 10 mL, and use this solution as the sample solution. Separately, dissolve 10 mg of ketoconazole in 10 mL of methanol, and use this solution as the standard solution. Perform the test with these solutions as directed under Thin-layer Chromatography <2.03>. Spot 5 μ L each of the sample solution and standard solution on a plate of silica gel with fluo-

rescent indicator for thin-layer chromatography. Develop the plate with a mixture of ethyl acetate, hexane, methanol, water and ammonia solution (28) (40:40:30:2:1) to a distance of about 10 cm, and air-dry the plate. Examine under ultraviolet light (main wavelength: 254 nm): the principal spot obtained from the sample solution has the same *R_f* value as the spot from the standard solution.

pH Being specified separately when the drug is granted approval based on the Law.

Assay To an exact amount of Ketoconazole Solution, equivalent to about 10 mg of ketoconazole (C₂₆H₂₈Cl₂N₄O₄), add exactly 5 mL of the internal standard solution, and add 15 mL of methanol. To 1 mL of this solution add methanol to make 25 mL, and use this solution as the sample solution. Separately, weigh accurately about 50 mg of ketoconazole for assay, previously dried at 105°C for 4 hours, and dissolve in methanol to make exactly 50 mL. Pipet 10 mL of this solution, add exactly 5 mL of the internal standard solution, add methanol to make 20 mL. Take 1 mL of this solution, add methanol to make 25 mL, and use this solution as the standard solution. Perform the test with 20 μL each of the sample solution and standard solution as directed under Liquid Chromatography <2.01> according to the following conditions, and calculate the ratios, *Q_T* and *Q_S*, of the peak area of ketoconazole to that of the internal standard.

$$\begin{aligned} \text{Amount (mg) of ketoconazole (C}_{26}\text{H}_{28}\text{Cl}_2\text{N}_4\text{O}_4) \\ = M_S \times Q_T / Q_S \times 1/5 \end{aligned}$$

M_S: Amount (mg) of ketoconazole for assay taken

Internal standard solution—A solution of bifonazole in methanol (3 in 2000).

Operating conditions—

Detector: An ultraviolet absorption photometer (wavelength: 240 nm).

Column: A stainless steel column 4.6 mm in inside diameter and 25 cm in length, packed with octadecylsilanized silica gel for liquid chromatography (5 μm in particle diameter).

Column temperature: A constant temperature of about 40°C.

Mobile phase: A mixture of a solution of diisopropylamine in methanol (1 in 500), ammonium acetate solution (1 in 200) and acetic acid (100) (1800:600:1).

Flow rate: Adjust so that the retention time of ketoconazole is about 11 minutes.

System suitability—

System performance: When the procedure is run with 20 μL of the standard solution under the above operating conditions, ketoconazole and the internal standard are eluted in this order with the resolution between these peaks being not less than 3.

System repeatability: When the test is repeated 6 times with 20 μL of the standard solution under the above operating conditions, the relative standard deviation of the ratio of the peak area of ketoconazole to that of the internal standard is not more than 1.0%.

Containers and storage Containers—Tight containers.

Ketoprofen

ケトプロフェン

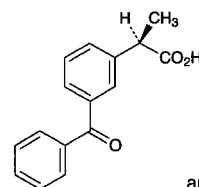

C₁₆H₁₄O₃: 254.28

(2*RS*)-2-(3-Benzoylphenyl)propanoic acid
[22071-15-4]

Ketoprofen, when dried, contains not less than 99.0% and not more than 100.5% of ketoprofen (C₁₆H₁₄O₃).

Description Ketoprofen occurs as a white crystalline powder.

It is very soluble in methanol, freely soluble in ethanol (95) and in acetone, and practically insoluble in water.

A solution of Ketoprofen in ethanol (99.5) (1 in 100) shows no optical rotation.

It is colored to pale yellow by light.

Identification (1) Determine the absorption spectrum of a solution of Ketoprofen in methanol (1 in 200,000) as directed under Ultraviolet-visible Spectrophotometry <2.24>, and compare the spectrum with the Reference Spectrum: both spectra exhibit similar intensities of absorption at the same wavelengths.

(2) Determine the infrared absorption spectrum of Ketoprofen, previously dried, as directed in the potassium bromide disk method under Infrared Spectrophotometry <2.25>, and compare the spectrum with the Reference Spectrum: both spectra exhibit similar intensities of absorption at the same wave numbers.

Melting point <2.60> 94 – 97°C

Purity (1) Clarity and color of solution—Dissolve 1.0 g of Ketoprofen in 10 mL of acetone: the solution is clear, and has no more color than the following control solution.

Control solution: To a mixture of 0.6 mL of Cobalt (II) Chloride CS and 2.4 mL of Iron (III) Chloride CS add diluted hydrochloric acid (1 in 10) to make 10 mL. To 5.0 mL of this solution add diluted hydrochloric acid (1 in 10) to make 100 mL.

(2) **Heavy metals** <1.07>—Proceed with 2.0 g of Ketoprofen according to Method 2, and perform the test. Prepare the control solution with 2.0 mL of Standard Lead Solution (not more than 10 ppm).

(3) **Related substances**—Conduct this procedure with a minimum of exposure to light, using light-resistant vessels. Dissolve 20 mg of Ketoprofen in 20 mL of the mobile phase, and use this solution as the sample solution. Pipet 1 mL of the sample solution, and add the mobile phase to make exactly 50 mL. Pipet 1 mL of this solution, add the mobile phase to make exactly 10 mL, and use this solution as the standard solution. Perform the test with exactly 20 μL each of the sample solution and standard solution as directed under Liquid Chromatography <2.01> according to the following conditions, and determine each peak area by the automatic integration method: the areas of the peaks, having the relative retention time of about 1.5 and about 0.3 to ketoprofen obtained from the sample solution, are not larger

than 4.5 times and not larger than 2 times the peak area of ketoprofen from the standard solution, respectively, the area of the peak other than ketoprofen and the peaks mentioned above from the sample solution is not larger than the peak area of ketoprofen from the standard solution, and the total area of these peaks is not larger than 2 times the peak area of ketoprofen from the standard solution.

Operating conditions—

Detector: An ultraviolet absorption photometer (wavelength: 233 nm).

Column: A stainless steel column 4.6 mm in inside diameter and 15 cm in length, packed with octadecylsilanized silica gel for liquid chromatography (5 μm in particle diameter).

Column temperature: A constant temperature of about 25°C.

Mobile phase: Dissolve 68.0 g of potassium dihydrogen phosphate in water to make 1000 mL, and adjust the pH to 3.5 with phosphoric acid. To 20 mL of this solution add 430 mL of acetonitrile and 550 mL of water.

Flow rate: Adjust so that the retention time of ketoprofen is about 7 minutes.

Time span of measurement: About 7 times as long as the retention time of ketoprofen.

System suitability—

Test for required detectability: To exactly 1 mL of the standard solution add the mobile phase to make exactly 10 mL. Confirm that the peak area of ketoprofen obtained with 20 μL of this solution is equivalent to 9 to 11% of that with 20 μL of the standard solution.

System performance: When the procedure is run with 20 μL of the standard solution under the above operating conditions, the number of theoretical plates and the symmetry factor of the peak of ketoprofen are not less than 8000 and not more than 1.5, respectively.

System repeatability: When the test is repeated 6 times with 20 μL of the standard solution under the above operating conditions, the relative standard deviation of the peak area of ketoprofen is not more than 2.0%.

Loss on drying <2.41> Not more than 0.5% (0.5 g, in vacuum, 60°C, 24 hours).

Residue on ignition <2.44> Not more than 0.1% (1 g).

Assay Weigh accurately about 0.3 g of Ketotifen, previously dried, dissolve in 25 mL of ethanol (95), add 25 mL of water, and titrate <2.50> with 0.1 mol/L sodium hydroxide VS (potentiometric titration). Perform a blank determination in the same manner, and make any necessary correction.

Each mL of 0.1 mol/L sodium hydroxide VS
= 25.43 mg of C₁₆H₁₄O₃

Containers and storage Containers—Tight containers.

Storage—Light-resistant.

Ketotifen Fumarate

ケトチフェンフマル酸塩

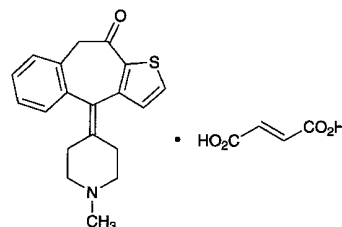

C₁₉H₁₉NOS.C₄H₄O₄: 425.50
4-(1-Methylpiperidin-4-ylidene)-4H-benzo[4,5]cyclohepta[1,2-b]thiophen-10(9H)-one monofumarate
[34580-14-8]

Ketotifen Fumarate, when dried, contains not less than 99.0% and not more than 101.0% of ketotifen fumarate (C₁₉H₁₉NOS.C₄H₄O₄).

Description Ketotifen Fumarate occurs as a white to light yellow-white crystalline powder.

It is sparingly soluble in methanol and in acetic acid (100), and slightly soluble in water, in ethanol (99.5) and in acetic anhydride.

Melting point: about 190°C (with decomposition).

Identification (1) Prepare the test solution with 30 mg of Ketotifen Fumarate as directed under Oxygen Flask Combustion Method <1.06> using 20 mL of water as the absorbing liquid; the test solution responds to Qualitative Tests <1.09> for sulfate.

(2) Determine the absorption spectrum of a solution of Ketotifen Fumarate in methanol (1 in 50,000) as directed under Ultraviolet-visible Spectrophotometry <2.24>, and compare the spectrum with the Reference Spectrum: both spectra exhibit similar intensities of absorption at the same wavelengths.

(3) Determine the infrared absorption spectrum of Ketotifen Fumarate, previously dried, as directed in the potassium bromide disk method under Infrared Spectrophotometry <2.25>, and compare the spectrum with the Reference Spectrum: both spectra exhibit similar intensities of absorption at the same wave numbers.

Purity (1) Chloride <1.03>—Dissolve 0.6 g of Ketotifen Fumarate in 2.5 mL of sodium carbonate TS in a crucible, heat on a water bath to dryness, and ignite at about 500°C. Dissolve the residue in 15 mL of water, filter if necessary, neutralize with diluted nitric acid (3 in 10), and add 6 mL of dilute nitric acid and water to make 50 mL. Perform the test using this solution as the test solution. Prepare the control solution as follows: To 0.25 mL of 0.01 mol/L hydrochloric acid VS add 2.5 mL of sodium carbonate TS, the used amount of diluted nitric acid (3 in 10) for the neutralization, 6 mL of dilute nitric acid and water to make 50 mL (not more than 0.015%).

(2) Heavy metals <1.07>—Proceed with 1.0 g of Ketotifen Fumarate according to Method 2, and perform the test. Prepare the control solution with 2.0 mL of Standard Lead Solution (not more than 20 ppm).

(3) Related substances—Dissolve 0.10 g of Ketotifen Fumarate in 10 mL of a mixture of methanol and ammonia TS (99:1), and use this solution as the sample solution. Pipet 1 mL of the sample solution, and add a mixture of methanol

and ammonia TS (99:1) to make exactly 25 mL. Pipet 1 mL of this solution, add a mixture of methanol and ammonia TS (99:1) to make exactly 20 mL, and use this solution as the standard solution. Perform the test with these solutions as directed under Thin-layer Chromatography <2.03>. Spot 10 μ L each of the sample solution and standard solution on a plate of silica gel for thin-layer chromatography. Develop the plate with a mixture of acetonitrile, water and ammonia solution (28) (90:10:1) to a distance of about 15 cm, and air-dry the plate. Spray evenly Dragendorff's TS for spraying and then hydrogen peroxide TS on the plate: the number of the spot other than the principal spot obtained from the sample solution is not more than four, and they are not more intense than the spot from the standard solution.

Loss on drying <2.41> Not more than 0.5% (1 g, 105°C, 4 hours).

Residue on ignition <2.44> Not more than 0.1% (1 g).

Assay Weigh accurately about 0.35 g of Ketotifen Fumarate, previously dried, dissolve in 80 mL of a mixture of acetic anhydride and acetic acid (100) (7:3), and titrate <2.50> with 0.1 mol/L perchloric acid VS (potentiometric titration). Perform a blank determination in the same manner, and make any necessary correction.

Each mL of 0.1 mol/L perchloric acid VS
= 42.55 mg of $C_{19}H_{19}NOS \cdot C_4H_4O_4$

Containers and storage Containers—Tight containers.

Kitasamycin

キサマイシン

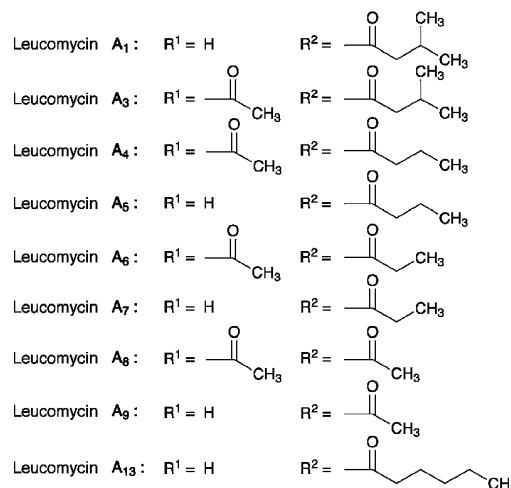
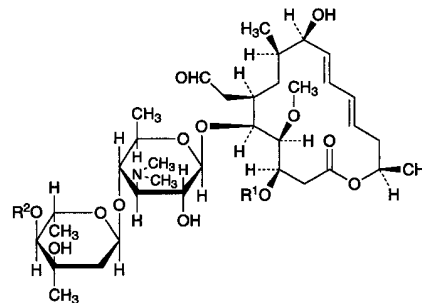

(Leucomycins A₁, A₅, A₇, A₉ and A₁₃)
(3*R*,4*R*,5*S*,6*R*,8*R*,9*R*,10*E*,12*E*,15*R*)-5-[4-*O*-Acyl-2,6-dideoxy-3-*C*-methyl- α -*L*-ribo-hexopyranosyl-(1 \rightarrow 4)-3,6-dideoxy-3-dimethylamino- β -*D*-glucopyranosyloxy]-6-formylmethyl-3,9-dihydroxy-4-methoxy-8-methylhexadeca-10,12-dien-15-olide

Leucomycin A₁ : acyl = 3-methylbutanoyl
Leucomycin A₅ : acyl = butanoyl
Leucomycin A₇ : acyl = propanoyl
Leucomycin A₉ : acyl = acetyl
Leucomycin A₁₃ : acyl = hexanoyl

(Leucomycins A₃, A₄, A₆ and A₈)
(3*R*,4*R*,5*S*,6*R*,8*R*,9*R*,10*E*,12*E*,15*R*)-3-Acetoxy-5-[4-*O*-acyl-2,6-dideoxy-3-*C*-methyl- α -*L*-ribo-hexopyranosyl-(1 \rightarrow 4)-3,6-dideoxy-3-dimethylamino- β -*D*-glucopyranosyloxy]-6-formylmethyl-9-hydroxy-4-methoxy-8-methylhexadeca-10,12-dien-15-olide

Leucomycin A₃ : acyl = 3-methylbutanoyl
Leucomycin A₄ : acyl = butanoyl
Leucomycin A₆ : acyl = propanoyl
Leucomycin A₈ : acyl = acetyl

[1392-21-8, Kitasamycin]

Kitasamycin is a mixture of macrolide substances having antibacterial activity produced by the growth of *Streptomyces kitasatoensis*.

It contains not less than 1450 μ g (potency) and not more than 1700 μ g (potency) per mg, calculated on the anhydrous basis. The potency of Kitasamycin is expressed as mass (potency) of kitasamycin corresponding to the mass of leucomycin A₅ ($C_{39}H_{65}NO_{14}$: 771.93). One mg (potency) of kitasamycin is equiva-

lent to 0.530 mg of leucomycin A₅ (C₃₉H₆₅NO₁₄).

Description Kitasamycin occurs as a white to light yellow-white powder.

It is very soluble in acetonitrile, in methanol and in ethanol (95), and practically insoluble in water.

Identification Determine the absorption spectrum of a solution of Kitasamycin in methanol (1 in 40,000) as directed under Ultraviolet-visible Spectrophotometry <2.24>, and compare the spectrum with the Reference Spectrum: both spectra exhibit similar intensities of absorption at the same wavelengths.

Content ratio of the active principle Dissolve 20 mg of Kitasamycin in diluted acetonitrile (1 in 2) to make 20 mL, and use this solution as the sample solution. Perform the test with 5 μ L of the sample solution as directed under Liquid Chromatography <2.01> according to the following conditions, and measure each peak area by the automatic integration method. Calculate the amounts of leucomycin A₅, leucomycin A₄ and leucomycin A₁ by the area percentage method: the amounts of leucomycin A₅, leucomycin A₄ and leucomycin A₁ are 40 to 70%, 5 to 25% and 3 to 12%, respectively. Relative retention times of leucomycin A₄ and leucomycin A₁ to leucomycin A₅ are about 1.2 and about 1.5, respectively.

Operating conditions—

Detector: An ultraviolet absorption photometer (wavelength: 232 nm).

Column: A stainless steel column 4.0 mm in inside diameter and 15 cm in length, packed with octylsilylated silica gel for liquid chromatography (5 μ m in particle diameter).

Column temperature: A constant temperature of about 40°C.

Mobile phase: To a volume of a solution of ammonium acetate (77 in 5000) add diluted phosphoric acid (1 in 150) to adjust to pH 5.5. To 370 mL of this solution add 580 mL of methanol and 50 mL of acetonitrile.

Flow rate: Adjust so that the retention time of leucomycin A₅ is about 8 minutes.

Time span of measurement: About 3 times as long as the retention time of leucomycin A₅.

System suitability—

System performance: Dissolve about 20 mg each of Leucomycin A₅ RS and Josamycin RS in 20 mL of diluted acetonitrile (1 in 2). When the procedure is run with 5 μ L of this solution under the above operating conditions, leucomycin A₅ and josamycin are eluted in this order with the resolution between these peaks being not less than 5.

System repeatability: When the test is repeated 6 times with 5 μ L of the sample solution under the above operating conditions, the relative standard deviation of the peak area of leucomycin A₅ is not more than 1.0%.

Water <2.48> Not more than 3.0% (0.1 g, volumetric titration, direct titration).

Assay Perform the test according to the Cylinder-plate method as directed under Microbial Assay for Antibiotics <4.02> according to the following conditions.

(i) Test organism—*Bacillus subtilis* ATCC 6632

(ii) Culture medium—Use the medium i in 1) under (1) Agar media for seed and base layer.

(iii) Standard solutions—Weigh accurately an amount of Leucomycin A₅ RS equivalent to about 30 mg (potency), dissolve in 10 mL of methanol, add water to make exactly 100 mL, and use this solution as the standard stock solution. Keep the standard stock solution at 5°C or below and use

within 3 days. Take exactly a suitable amount of the standard stock solution before use, add phosphate buffer solution (pH 8.0) to make solutions so that each mL contains 30 μ g (potency) and 7.5 μ g (potency), and use these solutions as the high concentration standard solution and the low concentration standard solution, respectively.

(iv) Sample solutions—Weigh accurately an amount of Kitasamycin equivalent to about 30 mg (potency), dissolve in 10 mL of methanol, and add water to make exactly 100 mL. Take exactly a suitable amount of the solution, add phosphate buffer solution (pH 8.0) to make solutions so that each mL contains 30 μ g (potency) and 7.5 μ g (potency), and use these solutions as the high concentration sample solution and the low concentration sample solution, respectively.

Containers and storage Containers—Tight containers.

Kitasamycin Acetate

キサマイシン酢酸エステル

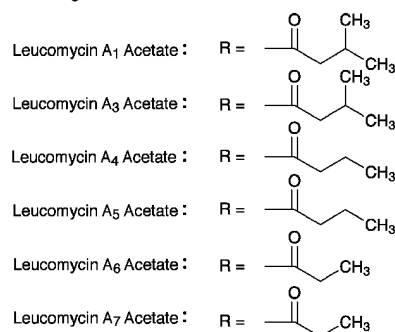
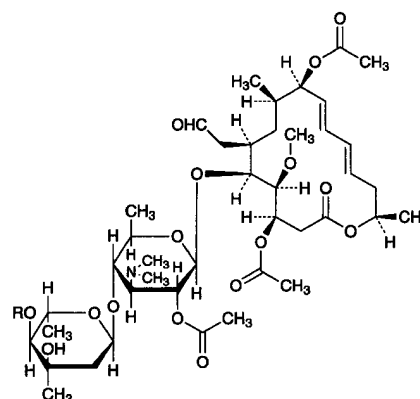

Leucomycin A₁ Acetate

(3*R*,4*R*,5*S*,6*R*,8*R*,9*R*,10*E*,12*E*,15*R*)-3,9-

Diacetoxy-5-[4-*O*-3-methylbutanoyl-2,6-dideoxy-3-*C*-methyl- α -*L*-ribo-hexopyranosyl-(1 \rightarrow 4)-2-*O*-acetyl-3,6-dideoxy-3-dimethylamino- β -*D*-glucopyranosyloxy]-6-formylmethyl-4-methoxy-8-methylhexadeca-10,12-dien-15-olide

Leucomycin A₃ Acetate

(3*R*,4*R*,5*S*,6*R*,8*R*,9*R*,10*E*,12*E*,15*R*)-3,9-

Diacetoxy-5-[4-*O*-3-methylbutanoyl-2,6-dideoxy-3-*C*-methyl- α -*L*-ribo-hexopyranosyl-(1 \rightarrow 4)-2-*O*-acetyl-3,6-dideoxy-3-dimethylamino- β -*D*-glucopyranosyloxy]-6-formylmethyl-4-methoxy-8-methylhexadeca-10,12-dien-15-olide

Leucomycin A₄ Acetate

(3*R*,4*R*,5*S*,6*R*,8*R*,9*R*,10*E*,12*E*,15*R*)-3,9-

Diacetoxy-5-[4-*O*-butanoyl-2,6-dideoxy-3-*C*-methyl- α -*L*-ribo-hexopyranosyl-(1 \rightarrow 4)-2-*O*-acetyl-3,6-dideoxy-3-dimethylamino- β -*D*-glucopyranosyloxy]-6-formylmethyl-4-methoxy-8-methylhexadeca-10,12-dien-15-olide

Leucomycin A₅ Acetate

(3*R*,4*R*,5*S*,6*R*,8*R*,9*R*,10*E*,12*E*,15*R*)-3,9-Diacetoxy-5-[4-*O*-butanoyl-2,6-dideoxy-3-*C*-methyl- α -*L*-ribo-hexopyranosyl-(1 \rightarrow 4)-2-*O*-acetyl-3,6-dideoxy-3-dimethylamino- β -*D*-glucopyranosyloxy]-6-formylmethyl-4-methoxy-8-methylhexadeca-10,12-dien-15-olide

Leucomycin A₆ Acetate

(3*R*,4*R*,5*S*,6*R*,8*R*,9*R*,10*E*,12*E*,15*R*)-3,9-Diacetoxy-5-[4-*O*-propanoyl-2,6-dideoxy-3-*C*-methyl- α -*L*-ribo-hexopyranosyl-(1 \rightarrow 4)-2-*O*-acetyl-3,6-dideoxy-3-dimethylamino- β -*D*-glucopyranosyloxy]-6-formylmethyl-4-methoxy-8-methylhexadeca-10,12-dien-15-olide

Leucomycin A₇ Acetate

(3*R*,4*R*,5*S*,6*R*,8*R*,9*R*,10*E*,12*E*,15*R*)-3,9-Diacetoxy-5-[4-*O*-propanoyl-2,6-dideoxy-3-*C*-methyl- α -*L*-ribo-hexopyranosyl-(1 \rightarrow 4)-2-*O*-acetyl-3,6-dideoxy-3-dimethylamino- β -*D*-glucopyranosyloxy]-6-formylmethyl-4-methoxy-8-methylhexadeca-10,12-dien-15-olide

[178234-32-7, Kitasamycin Acetate]

Kitasamycin Acetate is a derivative of kitasamycin.

It contains not less than 680 μ g (potency) and not more than 790 μ g (potency) per mg, calculated on the anhydrous basis. The potency of Kitasamycin Acetate is expressed as mass (potency) of kitasamycin corresponding to the mass of leucomycin A₅ (C₃₉H₆₅NO₁₄: 771.93). One mg (potency) of kitasamycin is equivalent to 0.530 mg of leucomycin A₅ (C₃₉H₆₅NO₁₄).

Description Kitasamycin Acetate occurs as a white to light yellow-white powder.

It is very soluble in methanol and in ethanol (95), and practically insoluble in water.

Identification (1) Determine the absorption spectrum of a solution of Kitasamycin Acetate in methanol (1 in 40,000) as directed under Ultraviolet-visible Spectrophotometry <2.24>, and compare the spectrum with the Reference Spectrum: both spectra exhibit similar intensities of absorption at the same wavelengths.

(2) Determine the infrared absorption spectrum of Kitasamycin Acetate as directed in the potassium bromide disk method under Infrared Spectrophotometry <2.25>, and compare the spectrum with the Reference Spectrum: both spectra exhibit similar intensities of absorption at the same wave numbers.

Water <2.48> Not more than 5.0% (0.1 g, volumetric titration, direct titration).

Assay Perform the test according to the Cylinder-plate method as directed under Microbial Assay for Antibiotics <4.02> according to the following conditions.

(i) Test organism—*Bacillus subtilis* ATCC 6633

(ii) Culture medium—Use the medium i in 1) under (1) Agar media for seed and base layer.

(iii) Standard solution—Weigh accurately an amount of Leucomycin A₅ RS equivalent to about 30 mg (potency), dissolve in 10 mL of methanol, add water to make exactly 100 mL, and use this solution as the standard stock solution. Keep the standard stock solution at 5°C or below and use within 3 days. Take exactly a suitable amount of the standard stock solution before use, add 0.1 mol/L phosphate buffer solution (pH 8.0) to make solutions so that each mL contains 30 μ g (potency) and 7.5 μ g (potency), and use these solutions as the high concentration standard solution and the low concentration standard solution, respectively.

(iv) Sample solution—Weigh accurately an amount of Kitasamycin Acetate equivalent to about 30 mg (potency), dissolve in 25 mL of methanol, add water to make exactly 50 mL, shake well, and allow to stand at 37 \pm 2°C for 24 hours. Take exactly a suitable amount of the solution, add 0.1 mol/L phosphate buffer solution (pH 8.0) to make solutions so that each mL contains 30 μ g (potency) and 7.5 μ g (potency), and use these solutions as the high concentration sample solution and the low concentration sample solution, respectively.

Containers and storage Containers—Tight containers.

Kitasamycin Tartrate

キサマイシン酒石酸塩

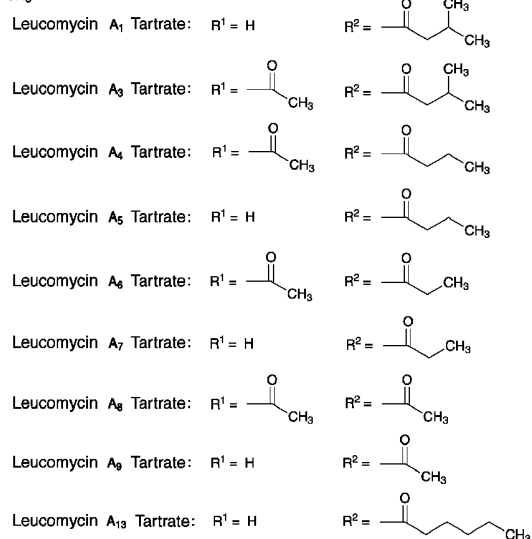
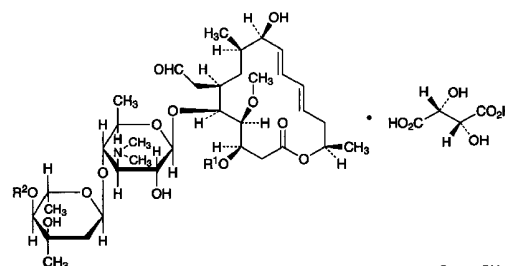
**Leucomycin A₁ Tartrate**

(3*R*,4*R*,5*S*,6*R*,8*R*,9*R*,10*E*,12*E*,15*R*)-5-[4-*O*-3-Methylbutanoyl-2,6-dideoxy-3-*C*-methyl- α -*L*-ribo-hexopyranosyl-(1 \rightarrow 4)-3,6-dideoxy-3-dimethylamino- β -*D*-glucopyranosyloxy]-6-formylmethyl-3,9-dihydroxy-4-methoxy-8-methylhexadeca-10,12-dien-15-olide mono-(2*R*,3*R*)-tartrate

Leucomycin A₃ Tartrate

(3*R*,4*R*,5*S*,6*R*,8*R*,9*R*,10*E*,12*E*,15*R*)-3-Acetoxy-5-[4-*O*-3-methylbutanoyl-2,6-dideoxy-3-*C*-methyl- α -*L*-ribo-hexopyranosyl-(1 \rightarrow 4)-3,6-dideoxy-3-dimethylamino- β -*D*-glucopyranosyloxy]-6-formylmethyl-9-hydroxy-4-methoxy-8-methylhexadeca-10,12-dien-15-olide mono-(2*R*,3*R*)-tartrate

Leucomycin A₄ Tartrate

(3*R*,4*R*,5*S*,6*R*,8*R*,9*R*,10*E*,12*E*,15*R*)-3-Acetoxy-5-[4-*O*-butanoyl-2,6-dideoxy-3-*C*-methyl- α -*L*-ribo-hexopyranosyl-(1 \rightarrow 4)-3,6-dideoxy-3-dimethylamino- β -*D*-glucopyranosyloxy]-6-formylmethyl-9-hydroxy-4-methoxy-8-methylhexadeca-10,12-dien-15-olide mono-(2*R*,3*R*)-tartrate

Leucomycin A₅ Tartrate

(3*R*,4*R*,5*S*,6*R*,8*R*,9*R*,10*E*,12*E*,15*R*)-5-[4-*O*-Butanoyl-2,6-dideoxy-3-*C*-methyl- α -*L*-ribo-hexopyranosyl-(1 \rightarrow 4)-3,6-dideoxy-3-dimethylamino- β -*D*-glucopyranosyloxy]-6-formylmethyl-3,9-dihydroxy-4-methoxy-8-methylhexadeca-10,12-dien-15-olide mono-(2*R*,3*R*)-tartrate

Leucomycin A₆ Tartrate

(3*R*,4*R*,5*S*,6*R*,8*R*,9*R*,10*E*,12*E*,15*R*)-3-Acetoxy-5-[4-*O*-propanoyl-2,6-dideoxy-3-*C*-methyl- α -*L*-ribo-hexopyranosyl-(1 \rightarrow 4)-3,6-dideoxy-3-dimethylamino- β -*D*-glucopyranosyloxy]-6-formylmethyl-9-hydroxy-4-methoxy-8-methylhexadeca-10,12-dien-15-olide mono-(2*R*,3*R*)-tartrate

Leucomycin A₇ Tartrate

(3*R*,4*R*,5*S*,6*R*,8*R*,9*R*,10*E*,12*E*,15*R*)-5-[4-*O*-Propanoyl-2,6-dideoxy-3-*C*-methyl- α -*L*-ribo-hexopyranosyl-(1 \rightarrow 4)-3,6-dideoxy-3-dimethylamino- β -*D*-glucopyranosyloxy]-6-formylmethyl-3,9-dihydroxy-4-methoxy-8-methylhexadeca-10,12-dien-15-olide mono-(2*R*,3*R*)-tartrate

Leucomycin A₈ Tartrate

(3*R*,4*R*,5*S*,6*R*,8*R*,9*R*,10*E*,12*E*,15*R*)-3-Acetoxy-5-[4-*O*-acetyl-2,6-dideoxy-3-*C*-methyl- α -*L*-ribo-hexopyranosyl-(1 \rightarrow 4)-3,6-dideoxy-3-dimethylamino- β -*D*-glucopyranosyloxy]-6-formylmethyl-9-hydroxy-4-methoxy-8-methylhexadeca-10,12-dien-15-olide mono-(2*R*,3*R*)-tartrate

Leucomycin A₉ Tartrate

(3*R*,4*R*,5*S*,6*R*,8*R*,9*R*,10*E*,12*E*,15*R*)-5-[4-*O*-Acetyl-2,6-dideoxy-3-*C*-methyl- α -*L*-ribo-hexopyranosyl-(1 \rightarrow 4)-3,6-dideoxy-3-dimethylamino- β -*D*-glucopyranosyloxy]-6-formylmethyl-3,9-dihydroxy-4-methoxy-8-methylhexadeca-10,12-dien-15-olide mono-(2*R*,3*R*)-tartrate

Leucomycin A₁₃ Tartrate

(3*R*,4*R*,5*S*,6*R*,8*R*,9*R*,10*E*,12*E*,15*R*)-5-[4-*O*-Hexanoyl-2,6-dideoxy-3-*C*-methyl- α -*L*-ribo-hexopyranosyl-(1 \rightarrow 4)-3,6-dideoxy-3-dimethylamino- β -*D*-glucopyranosyloxy]-6-formylmethyl-3,9-dihydroxy-4-methoxy-8-methylhexadeca-10,12-dien-15-olide mono-(2*R*,3*R*)-tartrate

[37280-56-1, Kitasamycin Tartrate]

Kitasamycin Tartrate is the tartrate of kitasamycin.

It contains not less than 1300 μ g (potency) and not more than 1500 μ g (potency) per mg, calculated on the anhydrous basis. The potency of Kitasamycin Tartrate is expressed as mass (potency) of kitasamycin based on the amount of leucomycin A₅ (C₃₉H₆₅NO₁₄: 771.93). One mg (potency) of Kitasamycin Tartrate is equivalent to 0.530 mg of leucomycin A₅ (C₃₉H₆₅NO₁₄).

Description Kitasamycin Tartrate occurs as a white to light yellow-white powder.

It is very soluble in water, in methanol and in ethanol (99.5).

Identification (1) Determine the absorption spectrum of a solution of Kitasamycin Tartrate in methanol (1 in 40,000) as directed under Ultraviolet-visible Spectrophotometry <2.24>, and compare the spectrum with the Reference Spectrum: both spectra exhibit similar intensities of absorption at the same wavelengths.

(2) Determine the infrared absorption spectrum of Kitasamycin Tartrate as directed in the potassium bromide disk method under Infrared Spectrophotometry <2.25>, and compare the spectrum with the Reference Spectrum: both spectra exhibit similar intensities of absorption at the same

wave numbers.

(3) Dissolve 1 g of Kitasamycin Tartrate in 20 mL of water, add 3 mL of sodium hydroxide TS, add 20 mL of *n*-butyl acetate, shake well, and discard the *n*-butyl acetate layer. To the aqueous layer add 20 mL of *n*-butyl acetate, and shake well. The aqueous layer so obtained responds to Qualitative Tests <1.09> (1) for tartrate.

pH <2.54> Dissolve 3.0 g of Kitasamycin Tartrate in 100 mL of water: the pH of the solution is between 3.0 and 5.0.

Content ratio of the active principle Dissolve 20 mg of Kitasamycin Tartrate in diluted acetonitrile (1 in 2) to make 20 mL, and use this solution as the sample solution. Perform the test with 5 μ L of the sample solution as directed under Liquid Chromatography <2.01> according to the following conditions, determine the peak areas by the automatic integration method, and calculate the amounts of leucomycin A₅, leucomycin A₄ and leucomycin A₁ by the area percentage method: the amount of leucomycin A₅ is 40 – 70%, leucomycin A₄ is 5 – 25%, and leucomycin A₁ is 3 – 12%. The relative retention times of leucomycin A₄ and leucomycin A₁ to leucomycin A₅ are about 1.2 and about 1.5, respectively.

Operating conditions—

Detector: An ultraviolet absorption photometer (wavelength: 232 nm).

Column: A stainless steel column 4.0 mm in inside diameter and 15 cm in length, packed with octylsilylated silica gel for liquid chromatography (5 μ m in particle diameter).

Column temperature: A constant temperature of about 40°C.

Mobile phase: To a suitable amount of a solution of ammonium acetate (77 in 5000) add diluted phosphoric acid (1 in 150) to adjust the pH to 5.5. To 370 mL of this solution add 580 mL of methanol and 50 mL of acetonitrile.

Flow rate: Adjust so that the retention time of leucomycin A₅ is about 8 minutes.

Time span of measurement: About 3 times as long as the retention time of leucomycin A₅.

System suitability—

System performance: Dissolve about 20 mg each of Leucomycin A₅ RS and Josamycin RS in 20 mL of diluted acetonitrile (1 in 2). When the procedure is run with 5 μ L of this solution under the above operating conditions, leucomycin A₅ and josamycin are eluted in this order with the resolution between these peaks being not less than 5.

System repeatability: When the test is repeated 6 times with 5 μ L of the sample solution under the above operating conditions, the relative standard deviation of the peak area of leucomycin A₅ is not more than 1.0%.

Purity (1) Clarity and color of solution—Dissolve 1.0 g of Kitasamycin Tartrate in 10 mL of water: the solution is clear and colorless or light yellow.

(2) Heavy metals <1.07>—Proceed with 1.0 g of Kitasamycin Tartrate according to Method 2, and perform the test. Prepare the control solution with 3.0 mL of Standard Lead Solution (not more than 30 ppm).

Water <2.48> Not more than 3.0% (0.1 g, volumetric titration, direct titration).

Assay Perform the test according to the Cylinder-plate method as directed under Microbial Assay for Antibiotics <4.02> according to the following conditions.

- (i) Test organism—*Bacillus subtilis* ATCC 6633
- (ii) Culture medium—Use the medium i in 1) under (1) Agar media for seed and base layer.
- (iii) Standard solutions—Weigh accurately an amount of

Leucomycin A₅ RS, equivalent to about 30 mg (potency), dissolve in 10 mL of methanol, add water to make exactly 100 mL, and use this solution as the standard stock solution. Keep the standard stock solution at not exceeding 5°C, and use within 3 days. Take exactly a suitable amount of the standard stock solution before use, add phosphate buffer solution (pH 8.0) to make solutions so that each mL contains 30 μg (potency) and 7.5 μg (potency), and use these solutions as the high concentration standard solution and the low concentration standard solution, respectively.

(iv) Sample solutions—Weigh accurately an amount of Kitasamycin Tartrate, equivalent to about 30 mg (potency), and dissolve in water to make exactly 100 mL. Take exactly a suitable amount of this solution, add phosphate buffer solution (pH 8.0) to make solutions so that each mL contains 30 μg (potency) and 7.5 μg (potency), and use these solutions as the high concentration sample solution and the low concentration sample solution, respectively.

Containers and storage Containers—Tight containers.

Labetalol Hydrochloride

ラベタロール塩酸塩

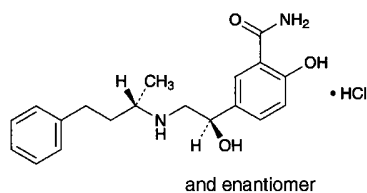
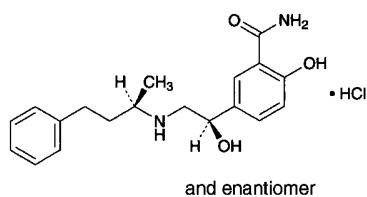

C₁₉H₂₄N₂O₃·HCl: 364.87

2-Hydroxy-5-[(1*R*S)-1-hydroxy-2-[(1*R*S)-1-methyl-3-phenylpropylamino]ethyl]benzamide monohydrochloride
2-Hydroxy-5-[(1*S*R)-1-hydroxy-2-[(1*S*R)-1-methyl-3-phenylpropylamino]ethyl]benzamide monohydrochloride
[32780-64-6]

Labetalol Hydrochloride, when dried, contains not less than 98.5% and not more than 101.0% of labetalol hydrochloride (C₁₉H₂₄N₂O₃·HCl).

Description Labetalol Hydrochloride occurs as a white crystalline powder.

It is freely soluble in methanol, and sparingly soluble in water and in ethanol (99.5).

It dissolves in 0.05 mol/L sulfuric acid TS.

Melting point: about 181°C (with decomposition).

Identification (1) Determine the absorption spectrum of a solution of Labetalol Hydrochloride in 0.05 mol/L sulfuric acid TS (1 in 20,000) as directed under Ultraviolet-visible Spectrophotometry <2.24>, and compare the spectrum with the Reference Spectrum: both spectra exhibit similar intensities of absorption at the same wavelengths.

(2) Determine the infrared absorption spectrum of Labetalol Hydrochloride as directed in the potassium chloride disc method under Infrared Spectrophotometry <2.25>,

and compare the spectrum with the Reference Spectrum: both spectra exhibit similar intensities of absorption at the same wave numbers.

(3) A solution of Labetalol Hydrochloride (1 in 50) responds to Qualitative Tests <1.09> for chloride.

pH <2.54> The pH of a solution prepared by dissolving 0.5 g of Labetalol Hydrochloride in 50 mL of water is between 4.0 and 5.0.

Purity (1) Heavy metals <1.07>—Proceed with 1.0 g of Labetalol Hydrochloride according to Method 2, and perform the test. Prepare the control solution with 2.0 mL of Standard Lead Solution (not more than 20 ppm).

(2) Related substances—Dissolve 0.8 g of Labetalol Hydrochloride in 10 mL of methanol, and use this solution as the sample solution. Pipet 1 mL of the sample solution, add methanol to make exactly 200 mL, and use this solution as the standard solution. Perform the test with these solutions as directed under Thin-layer Chromatography <2.03>. Spot 5 μL each of the sample solution and standard solution on a plate of silica gel for thin-layer chromatography. Develop the plate with a mixture of ethyl acetate, 2-propanol, water, and ammonia solution (28) (25:15:8:2) to a distance of about 10 cm, and air-dry the plate. Allow the plate to stand in iodine vapor for 30 minutes: the spots other than the principal spot obtained from the sample solution do not exceed 2 in number and are not more intense than the spot from the standard solution.

Loss on drying <2.41> Not more than 1.0% (1 g, 105°C, 3 hours).

Residue on ignition <2.44> Not more than 0.1% (1 g).

Isomer ratio Dissolve 5 mg of Labetalol Hydrochloride in 0.7 mL of a solution of *n*-butylboronic acid in dehydrated pyridine (3 in 250), allow to stand for 20 minutes, and use this solution as the sample solution. Perform the test with 2 μL of the sample solution as directed under Gas Chromatography <2.02> according to the following conditions. Determine the areas of two adjacent peaks, A_a and A_b, where A_a is the peak area of the shorter retention time and A_b is the peak area of the longer retention time, using the automatic integration method: the ratio A_b/(A_a + A_b) is between 0.45 and 0.55.

Operating conditions—

Detector: A hydrogen flame-ionization detector.

Column: A fused silica column 0.53 mm in inside diameter and 25 m in length, coated inside with methyl silicone polymer for gas chromatography in 5 μm thickness.

Column temperature: A constant temperature of about 290°C.

Injection port temperature: A constant temperature of about 350°C.

Detector temperature: A constant temperature of about 350°C.

Carrier gas: Helium.

Flow rate: Adjust so that the retention time of the peak showing earlier elution of the two peaks of labetalol is about 9 minutes.

System suitability—

System performance: Proceed with 2 μL of the sample solution under the above conditions: the resolution between the two labetalol peaks is not less than 1.5.

System repeatability: Repeat the test 6 times under the above conditions with 2 μL of the sample solution: the relative standard deviation of the ratio of the peak area of labetalol with the shorter retention time to that of the longer

retention time is not more than 2.0%.

Assay Weigh accurately about 0.3 g of Labetalol Hydrochloride, previously dried, dissolve in 100 mL of a mixture of acetic anhydride and acetic acid (100) (7:3), and titrate <2.50> with 0.1 mol/L perchloric acid VS (potentiometric titration). Perform a blank determination in the same manner, and make any necessary correction.

Each mL of 0.1 mol/L perchloric acid VS
= 36.49 mg of $C_{19}H_{24}N_2O_3 \cdot HCl$

Containers and storage Containers—Tight containers.

Labetalol Hydrochloride Tablets

ラベタロール塩酸塩錠

Labetalol Hydrochloride Tablets contain not less than 93.0% and not more than 107.0% of the labeled amount of labetalol hydrochloride ($C_{19}H_{24}N_2O_3 \cdot HCl$; 364.87).

Method of preparation Prepare as directed under Tablets, with Labetalol Hydrochloride.

Identification (1) To a quantity of powdered Labetalol Hydrochloride Tablets equivalent to 5 mg of Labetalol Hydrochloride, add 100 mL of 0.05 mol/L sulfuric acid TS, shake, and filter. Determine the absorption spectrum of the filtrate as directed under Ultraviolet-visible Spectrophotometry <2.24>: it exhibits a maximum between 300 nm and 304 nm.

(2) To a quantity of powdered Labetalol Hydrochloride Tablets equivalent to 0.25 g of Labetalol Hydrochloride, add 25 mL of methanol, shake vigorously for 30 minutes, filter, and use the filtrate as the sample solution. Separately, dissolve 10 mg of labetalol hydrochloride in 1 mL of methanol, and use this solution as the standard solution. Perform the test using these solutions as directed under Thin-layer Chromatography <2.03>. Spot 5 μ L each of the sample solution and standard solution on a plate of silica gel with fluorescent indicator for thin-layer chromatography. Develop the plate with a mixture of ethyl acetate, 2-propanol, water, and ammonia solution (28) (25:15:8:2) to a distance of about 10 cm, and air-dry the plate. Examine under ultraviolet light (main wavelength: 254 nm): the principal spot obtained from the sample solution and the spot from the standard solution show the same *R_f* value.

Uniformity of dosage units <6.02> Perform the Mass variation test, or the Content uniformity test according to the following method: it meets the requirement.

To 1 tablet of Labetalol Hydrochloride Tablets add 5 mL of 0.5 mol/L sulfuric acid TS and 30 mL of water, shake vigorously for 30 minutes, add water to make exactly 50 mL, and filter. Discard the first 5 mL of the filtrate, pipet 4 mL of the subsequent filtrate, add 0.05 mol/L sulfuric acid TS to make exactly *V* mL so that each mL contains about 40 μ g of labetalol hydrochloride ($C_{19}H_{24}N_2O_3 \cdot HCl$), and use this solution as the sample solution. Separately, weigh accurately about 20 mg of labetalol hydrochloride for assay, previously dried at 105°C for 3 hours, and dissolve in 0.05 mol/L sulfuric acid TS to make exactly 50 mL. Pipet 5 mL of this solution, add 0.05 mol/L sulfuric acid TS to make exactly 50 mL, and use this solution as the standard solution. Determine the absorbances, A_T and A_S , of the sample solution and standard solution at 302 nm as directed under Ultraviolet-

visible Spectrophotometry <2.24>.

Amount (mg) of labetalol hydrochloride ($C_{19}H_{24}N_2O_3 \cdot HCl$)
= $M_S \times A_T / A_S \times V / 40$

M_S : Amount (mg) of labetalol hydrochloride for assay taken

Dissolution <6.10> When the test is performed at 50 revolutions per minute according to the Paddle method, using 900 mL of water as the dissolution medium, the dissolution rate in 30 minutes of Labetalol Hydrochloride Tablets is not less than 75%.

Start the test with 1 tablet of Labetalol Hydrochloride Tablets, withdraw not less than 20 mL of the medium at specified minute after starting the test, and filter through a membrane filter with a pore size not exceeding 0.8 μ m. Discard not less than 10 mL of the first filtrate, pipet *V* mL of the subsequent filtrate, and add water to make exactly *V'* mL so that each mL contains about 50 μ g of labetalol hydrochloride ($C_{19}H_{24}N_2O_3 \cdot HCl$), and use this solution as the sample solution. Separately, weigh accurately about 50 mg of labetalol hydrochloride for assay, previously dried at 105°C for 3 hours, and dissolve in water to make exactly 100 mL. Pipet 10 mL of this solution, add water to make exactly 100 mL, and use this solution as the standard solution. Perform the test with the sample solution and standard solution as directed under Ultraviolet-visible Spectrophotometry <2.24>, and determine the absorbances, A_T and A_S , at 302 nm.

Dissolution rate (%) with respect to the labeled amount of labetalol hydrochloride ($C_{19}H_{24}N_2O_3 \cdot HCl$)
= $M_S \times A_T / A_S \times V' / V \times 1 / C \times 90$

M_S : Amount (mg) of labetalol hydrochloride for assay taken

C: Labeled amount (mg) of labetalol hydrochloride ($C_{19}H_{24}N_2O_3 \cdot HCl$) in 1 tablet

Assay Weigh accurately not less than 20 Labetalol Hydrochloride Tablets, and powder. Weigh accurately a portion of the powder, equivalent to about 1 g of labetalol hydrochloride ($C_{19}H_{24}N_2O_3 \cdot HCl$), add 100 mL of 0.5 mol/L sulfuric acid TS and 600 mL of water, shake vigorously for 30 minutes, add water to make exactly 1000 mL, and filter. Discard the first 5 mL of the filtrate, pipet 5 mL of the subsequent filtrate, and add 0.05 mol/L sulfuric acid TS to make exactly 25 mL. Pipet 5 mL of this solution, add 0.05 mol/L sulfuric acid TS to make exactly 25 mL, and use this solution as the sample solution. Separately, weigh accurately about 40 mg of labetalol hydrochloride for assay, previously dried at 105°C for 3 hours, and dissolve in 0.05 mol/L sulfuric acid TS to make exactly 100 mL. Pipet 5 mL of this solution, add 0.05 mol/L sulfuric acid TS to make exactly 50 mL, and use this solution as the standard solution. Perform the test with the sample solution and standard solution as directed under Ultraviolet-visible Spectrophotometry <2.24>, and determine the absorbances, A_T and A_S , at 302 nm.

Amount (mg) of labetalol hydrochloride ($C_{19}H_{24}N_2O_3 \cdot HCl$)
= $M_S \times A_T / A_S \times 25$

M_S : Amount (mg) of labetalol hydrochloride for assay taken

Containers and storage Containers—Tight containers.

Lactic Acid

乳酸

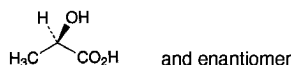

$C_3H_6O_3$: 90.08

(2*RS*)-2-Hydroxypropanoic acid

[50-21-5]

Lactic Acid is a mixture of lactic acid and lactic anhydride.

It contains not less than 85.0% and not more than 92.0% of lactic acid ($C_3H_6O_3$).

Description Lactic Acid occurs as a clear, colorless or light yellow, viscous liquid. It is odorless or has a faint, unpleasant odor.

It is miscible with water, with ethanol (95) and with diethyl ether.

It is hygroscopic.

Specific gravity d_{20}^{20} : about 1.20

Identification A solution of Lactic Acid (1 in 50) changes blue litmus paper to red and responds to Qualitative Tests <1.09> for lactate.

Purity (1) Chloride <1.03>—Perform the test with 1.0 g of Lactic Acid. Prepare the control solution with 1.0 mL of 0.01 mol/L hydrochloric acid VS (not more than 0.036%).

(2) Sulfate <1.14>—Perform the test with 2.0 g of Lactic Acid. Prepare the control solution with 0.40 mL of 0.005 mol/L sulfuric acid VS (not more than 0.010%).

(3) Heavy metals <1.07>—To 2.0 g of Lactic Acid add 10 mL of water and 1 drop of phenolphthalein TS, and add ammonia TS dropwise until a pale red color appears. Add 2 mL of dilute acetic acid and water to make 50 mL, and perform the test using this solution as the test solution. Prepare the control solution from 2.0 mL of Standard Lead Solution and 2 mL of dilute acetic acid, and dilute with water to 50 mL (not more than 10 ppm).

(4) Iron <1.10>—Prepare the test solution with 4.0 g of Lactic Acid according to Method 1, and perform the test according to Method A. Prepare the control solution with 2.0 mL of Standard Iron Solution (not more than 5 ppm).

(5) Sugars—To 1.0 g of Lactic Acid add 10 mL of water, and neutralize with sodium hydroxide TS. Boil the mixture with 10 mL of Fehling's TS for 5 minutes: no red precipitate is produced.

(6) Citric, oxalic, phosphoric and L-tartaric acid—To 1.0 g of Lactic Acid add 1.0 mL of water, followed by 40 mL of calcium hydroxide TS. Boil the mixture for 2 minutes: no change occurs.

(7) Glycerin or mannitol—Shake 10 mL of Lactic Acid with 12 mL of diethyl ether: no turbidity is produced.

(8) Volatile fatty acids—Warm Lactic Acid: it does not produce any acetic acid-like or butyric acid-like odor.

(9) Cyanide—Transfer 1.0 g of Lactic Acid to a Nessler tube, add 10 mL of water and 1 drop of phenolphthalein TS, add dropwise a solution of sodium hydroxide (1 in 10) by shaking until a pale red color develops, add 1.5 mL of a solution of sodium hydroxide (1 in 10) and water to make 20 mL, and heat in a water bath for 10 minutes. Cool, add dropwise dilute acetic acid until a red color of the solution disappears, add 1 drop of dilute acetic acid, add 10 mL of phosphate buffer solution (pH 6.8), and 0.25 mL of sodium toluenesulfonchloramide TS, stopper immediately, mix

gently, and allow to stand for 5 minutes. To the solution add 15 mL of pyridine-pyrazolone TS and water to make 50 mL, and allow to stand at 25°C for 30 minutes: the solution has no more color than the following control solution.

Control solution: Pipet 1.0 mL of Standard Cyanide Solution, and add water to make exactly 20 mL. Transfer 1.0 mL of this solution to a Nessler tube, add 10 mL of water and 1 drop of phenolphthalein TS, and then proceed as described above.

(10) Readily carbonizable substances—Superimpose slowly 5 mL of Lactic Acid, previously kept at 15°C, upon 5 mL of sulfuric acid for readily carbonizable substances, previously kept at 15°C, and allow to stand at 15°C for 15 minutes: no dark color develops at the zone of contact.

Residue on ignition <2.44> Not more than 0.1% (1 g).

Assay Weigh accurately about 3 g of Lactic Acid, transfer in a conical flask, add accurately measured 40 mL of 1 mol/L sodium hydroxide VS, invert a watch glass over the flask, and heat on a water bath for 10 minutes. Titrate <2.50> the excess sodium hydroxide with 0.5 mol/L sulfuric acid VS immediately (indicator: 2 drops of phenolphthalein TS). Perform a blank determination in the same manner.

Each mL of 1 mol/L sodium hydroxide VS
= 90.08 mg of $C_3H_6O_3$

Containers and storage Containers—Tight containers.

L-Lactic Acid

L-乳酸

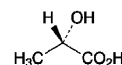

$C_3H_6O_3$: 90.08

(2*S*)-2-Hydroxypropanoic acid

[79-33-4]

L-Lactic Acid is a mixture of L-lactic acid and L-lactic anhydride.

It contains not less than 85.0% and not more than 92.0% of L-lactic acid ($C_3H_6O_3$).

Description L-Lactic Acid occurs as a clear, colorless or light yellow, viscous liquid. It is odorless or has a faint, no unpleasant odor.

It is miscible with water, with ethanol (99.5) and with diethyl ether.

It is hygroscopic.

Specific gravity d_{20}^{20} : about 1.20

Identification A solution of L-Lactic Acid (1 in 50) changes the color of blue litmus paper to red, and responds to Qualitative Tests <1.09> for lactate.

Optical rotation <2.49> $[\alpha]_D^{20}$: $-46 - -52^\circ$ Weigh accurately an amount of L-Lactic Acid, equivalent to about 2 g of L-lactic acid ($C_3H_6O_3$), add exactly 25 mL of 1 mol/L sodium hydroxide VS, cover with a watch glass, and heat on a water bath for 15 minutes. Cool, and adjust to pH 7.0 with 1 mol/L hydrochloric acid VS. Dissolve 5.0 g of hexaammonium heptamolybdate tetrahydrate in this solution, add water to make exactly 50 mL, and determine the optical rotation using a 100-mm cell.

Purity (1) Chloride <1.03>—Perform the test with 1.0 g of L-Lactic Acid. Prepare the control solution with 1.0 mL of

0.01 mol/L hydrochloric acid VS (not more than 0.036%).

(2) Sulfate <1.14>—Perform the test with 2.0 g of L-Lactic Acid. Prepare the control solution with 0.40 mL of 0.005 mol/L sulfuric acid VS (not more than 0.010%).

(3) Heavy metals <1.07>—To 2.0 g of L-Lactic Acid add 10 mL of water and 1 drop of phenolphthalein TS, and add ammonia TS dropwise until a pale red color appears. Add 2 mL of dilute acetic acid and water to make 50 mL, and perform the test using this solution as the test solution. Prepare the control solution from 2.0 mL of Standard Lead Solution and 2 mL of dilute acetic acid, and dilute with water to 50 mL (not more than 10 ppm).

(4) Iron <1.10>—Prepare the test solution with 4.0 g of L-Lactic Acid according to Method 1, and perform the test according to Method A. Prepare the control solution with 2.0 mL of Standard Iron Solution (not more than 5 ppm).

(5) Sugars—To 1.0 g of L-Lactic Acid add 10 mL of water, and neutralize with sodium hydroxide TS. Boil the mixture with 10 mL of Fehling's TS for 5 minutes: no red precipitate is produced.

(6) Citric, oxalic, phosphoric and L-tartaric acid—To 1.0 g of L-Lactic Acid add 1.0 mL of water, followed by 40 mL of calcium hydroxide TS. Boil the mixture for 2 minutes: no change occurs.

(7) Glycerin or mannitol—Shake 10 mL of L-Lactic Acid with 12 mL of diethyl ether: no turbidity is produced.

(8) Volatile fatty acids—Warm L-Lactic Acid: it does not produce any acetic acid-like or butyric acid-like odor.

(9) Cyanide—Transfer 1.0 g of L-Lactic Acid to a Nessler tube, add 10 mL of water and 1 drop of phenolphthalein TS, add dropwise a solution of sodium hydroxide (1 in 10) while shaking until a pale red color develops, then add 1.5 mL of a solution of sodium hydroxide (1 in 10) and water to make 20 mL, and heat in a water bath for 10 minutes. After cooling, add dropwise dilute acetic acid until a red color of the solution disappears, add 1 drop of dilute acetic acid, 10 mL of phosphate buffer solution (pH 6.8) and 0.25 mL of sodium toluenesulfonchloramide TS, stopper immediately, mix gently, and allow to stand for 5 minutes. To the solution add 15 mL of pyridine-pyrazolone TS and water to make 50 mL, and allow to stand at 25°C for 30 minutes: the solution has no more color than the following control solution.

Control solution: Pipet 1.0 mL of Standard Cyanide Solution, and add water to make 20 mL. Transfer 1.0 mL of this solution to a Nessler tube, add 10 mL of water and 1 drop of phenolphthalein TS, and then proceed as described above.

(10) Readily carbonizable substances—Superimpose slowly 5 mL of L-Lactic Acid, previously kept at 15°C, upon 5 mL of sulfuric acid for readily carbonizable substances, previously kept at 15°C, and allow to stand at 15°C for 15 minutes: no dark color develops at the zone of contact.

Residue on ignition <2.44> Not more than 0.1% (1 g).

Assay Weigh accurately about 3 g of L-Lactic Acid, transfer in a conical flask, add accurately measured 40 mL of 1 mol/L sodium hydroxide VS, invert a watch glass over the flask, and heat on a water bath for 10 minutes. Titrate <2.50> the excess sodium hydroxide with 0.5 mol/L sulfuric acid VS immediately (indicator: 2 drops of phenolphthalein TS). Perform a blank determination in the same manner.

Each mL of 1 mol/L sodium hydroxide VS
= 90.08 mg of C₃H₆O₃

Containers and storage Containers—Tight containers.

Anhydrous Lactose

無水乳糖

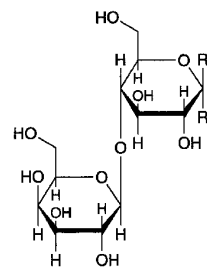

α -Lactose : R¹=H, R²=OH
 β -Lactose : R¹=OH, R²=H

C₁₂H₂₂O₁₁: 342.30

β -D-Galactopyranosyl-(1→4)- β -D-glucopyranose
(β -lactose)

β -D-Galactopyranosyl-(1→4)- α -D-glucopyranose
(α -lactose)

[63-42-3, Anhydrous Lactose]

This monograph is harmonized with the European Pharmacopoeia and the U.S. Pharmacopoeia.

The corresponding part of the attributes/provisions which are agreed as non-harmonized within the scope of the harmonization is marked with symbols (◆ ◆), and the corresponding parts which are agreed as the JP local requirement other than the scope of the harmonization are marked with symbols (◇ ◇).

Information on the harmonization with the European Pharmacopoeia and the U.S. Pharmacopoeia is available on the website of the Pharmaceuticals and Medical Devices Agency.

Anhydrous Lactose is β -lactose or a mixture of β -lactose and α -lactose.

◆The relative quantities of α -lactose and β -lactose in Anhydrous Lactose is labeled as the isomer ratio.◆

◆**Description** Anhydrous Lactose occurs as white, crystals or powder.

It is freely soluble in water, and practically insoluble in ethanol (99.5).◆

Identification Determine the infrared absorption spectrum of Anhydrous Lactose, previously dried, as directed in the potassium bromide disk method under Infrared Spectrophotometry <2.25>, and compare the spectrum with the Reference Spectrum or the spectrum of Anhydrous Lactose for Identification RS: both spectra exhibit similar intensities of absorption at the same wave numbers.

Optical rotation <2.49> [α]_D²⁰: +54.4 – +55.9° Weigh accurately about 10 g of Anhydrous Lactose, calculated on the anhydrous basis, dissolve in 80 mL of water warmed to 50°C, and add 0.2 mL of ammonia TS after cooling. After standing for 30 minutes, add water to make exactly 100 mL, and determine the optical rotation of this solution in a 100-mm cell.

Purity (1) Clarity and color of solution—Dissolve 1.0 g of Anhydrous Lactose in 10 mL of boiling water, and allow to cool: the solution is clear, and colorless or nearly colorless and has no more color than the following control solution. Determine the absorbance at 400 nm of this solution as directed under Ultraviolet-visible Spectrophotometry <2.24>.

using water as the control solution: not more than 0.04.

Control solution: To a mixture of 2.5 mL of Cobalt (II) Chloride CS, 6.0 mL of Iron (III) Chloride CS and 1.0 mL of Copper (II) Sulfate CS, add diluted dilute hydrochloric acid (1 in 10) to make 1000 mL.

(2) Acidity or alkalinity—Dissolve 6 g of Anhydrous Lactose by heating in 25 mL of freshly boiled and cooled water, and after cooling, add 0.3 mL of phenolphthalein TS: the solution is colorless, and not more than 0.4 mL of 0.1 mol/L sodium hydroxide VS is required to produce a pink or red color.

◇(3) Heavy metals <1.07>—Proceed with 4.0 g of Anhydrous Lactose according to Method 2, and perform the test. Prepare the control solution with 2.0 mL of Standard Lead Solution (not more than 5 ppm).◇

(4) Proteins and light absorbing substances—Dissolve 1.0 g of Anhydrous Lactose in water to make 100 mL, and use this solution as the sample solution. Determine the absorbances of the sample solution as directed under Ultraviolet-visible Spectrophotometry <2.24>, using water as the control solution: not more than 0.25 at between 210 nm and 220 nm, and not more than 0.07 at between 270 nm and 300 nm.

Loss on drying <2.41> Not more than 0.5% (1 g, 80°C, 2 hours).

Water <2.48> Not more than 1.0% (1 g, volumetric titration, direct titration. Use a mixture of methanol for water determination and formamide for water determination (2:1) instead of methanol for water determination).

Residue on ignition <2.44> Not more than 0.1% (1 g).

Microbial limit <4.05> The acceptance criteria of TAMC and TYMC are 10^2 CFU/g and 5×10^1 CFU/g, respectively, and ◇*Salmonella* and ◇*Escherichia coli* are not observed.

Isomer ratio Place 10 mg of Anhydrous Lactose in a screw capped reaction vial for gas chromatography, add 4 mL of a mixture of pyridine, trimethylsilylimidazole and dimethylsulfoxide (117:44:39), stopper, and sonicate at room temperature for 20 minutes. After cooling, transfer 400 μ L of this solution into a vial for injection, add 1 mL of pyridine, stopper tightly, mix, and use this fluid as the sample solution. Perform the test with 0.5 μ L of the sample solution as directed under Gas Chromatography <2.02> according to the following conditions. Determine the peak areas of α -lactose and β -lactose, A_a and A_b , and calculate the contents (%) of α -lactose and β -lactose in Anhydrous Lactose by the following equations.

$$\text{Content (\%)} \text{ of } \alpha\text{-lactose} = A_a / (A_a + A_b) \times 100$$

$$\text{Content (\%)} \text{ of } \beta\text{-lactose} = A_b / (A_a + A_b) \times 100$$

Operating conditions—

Detector: A hydrogen flame-ionization detector.

Column: A fused silica column 0.25 mm in inside diameter and 15 m in length, coated with 5% diphenyl-95% dimethylpolysiloxane in 0.25 μ m thickness. Use a middle polar inertness fused silica column 0.53 mm in inside diameter and 2 m in length as a guard column.

Column temperature: Maintain the temperature at 80°C for 1 minute after injection, raise to 150°C at a rate of 35°C per minute, then raise to 300°C at a rate of 12°C per minute, and maintain at 300°C for 2 minutes.

Injection port temperature: A constant temperature of about 275°C, or use cold-on column injection.

Detector temperature: A constant temperature of about 325°C.

Carrier gas: Helium.

Flow rate: 2.8 mL per minute (Retention time of β -lactose is about 12 minutes).

Splitless.

System suitability—

System performance: Prepare a solution with 10 mg of a mixture of α -lactose and β -lactose (1:1) in the same manner as for preparing the sample solution, and proceed with 0.5 μ L of this solution under the above operating conditions, and determine the retention times of the peaks of α -lactose and β -lactose: the relative retention time of α -lactose to β -lactose is about 0.9 with the resolution between these peaks being not less than 3.0.

◇System repeatability: When the test is repeated 6 times with 0.5 μ L of the solution used in the system performance under the above operating conditions, the relative standard deviation of the peak area of β -lactose is not more than 5.0%.◇

◆**Containers and storage** Containers—Well-closed containers.◆

Lactose Hydrate

乳糖水和物

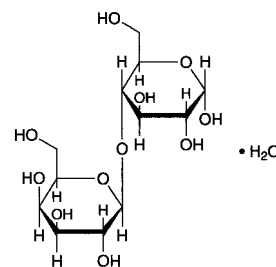

$C_{12}H_{22}O_{11} \cdot H_2O$: 360.31

β -D-Galactopyranosyl-(1 \rightarrow 4)- α -D-glucopyranose monohydrate

[64044-51-5, Mixture of α - and β -lactose monohydrate]

This monograph is harmonized with the European Pharmacopoeia and the U.S. Pharmacopoeia.

The corresponding part of the attributes/provisions which are agreed as non-harmonized within the scope of the harmonization is marked with symbols (◆ ◆), and the corresponding parts which are agreed as the JP local requirement other than the scope of the harmonization are marked with symbols (◇ ◇).

Information on the harmonization with the European Pharmacopoeia and the U.S. Pharmacopoeia is available on the website of the Pharmaceuticals and Medical Devices Agency.

Lactose Hydrate is the monohydrate of β -D-galactopyranosyl-(1 \rightarrow 4)- α -D-glucopyranose.

◇It is a disaccharide obtained from milk, consist of one unit of glucose and one unit of galactose.◇

◆The label states the effect where it is the granulated powder.◆

◆**Description** Lactose Hydrate occurs as white, crystals, powder or granulated powder.

It is freely soluble in water, and practically insoluble in ethanol (99.5).◆

Identification Determine the infrared absorption spectrum of Lactose Hydrate, previously dried, as directed in the potassium bromide disk method under Infrared Spectropho-

tometry <2.25>, and compare the spectrum with the Reference Spectrum or the spectrum of Lactose for Identification RS: both spectra exhibit similar intensities of absorption at the same wave numbers.

Optical rotation <2.49> $[\alpha]_D^{20}$: +54.4 – +55.9°. Weigh accurately about 10 g of Lactose Hydrate, calculated on the anhydrous basis, dissolve in 80 mL of water warmed to 50°C, and add 0.2 mL of ammonia TS after cooling. After standing for 30 minutes, add water to make exactly 100 mL, and determine the optical rotation of this solution in a 100-mm cell.

Purity (1) Clarity and color of solution—Dissolve 1.0 g of Lactose Hydrate in 10 mL of hot water, allow to cool, and determine the turbidity of this solution as directed under Turbidity Measurement <2.61>: it is clear, and has no more color than the following control solution. Determine the absorbance at 400 nm of this solution as directed under Ultraviolet-visible Spectrophotometry <2.24>, using water as the control solution: not more than 0.04.

Control solution: To 2.5 mL of Cobalt (II) Chloride CS, 6.0 mL of Iron (III) Chloride CS and 1.0 mL of Copper (II) Sulfate CS add diluted dilute hydrochloric acid (1 in 10) to make 1000 mL.

(2) Acidity or alkalinity—Dissolve 6 g of Lactose Hydrate by heating in 25 mL of freshly boiled and cooled water, and after cooling, add 0.3 mL of phenolphthalein TS: the solution is colorless, and not more than 0.4 mL of 0.1 mol/L sodium hydroxide VS is required to produce a pale red color or red color.

◇(3) Heavy metals <1.07>—Dissolve 4.0 g of Lactose Hydrate in 20 mL of warm water, add 1 mL of 0.1 mol/L hydrochloric acid TS and water to make 50 mL. Proceed with this solution according to Method 1, and perform the test. Prepare the control solution with 2.0 mL of Standard Lead Solution and 1 mL of 0.1 mol/L hydrochloric acid TS (not more than 5 ppm).◇

(4) Proteins and light absorbing substances—Dissolve 1.0 g of Lactose Hydrate in water to make 100 mL, and use this solution as the sample solution. Determine the absorbances of the sample solution as directed under Ultraviolet-visible Spectrophotometry <2.24>, using water as the control solution: not more than 0.25 at between 210 nm and 220 nm, and not more than 0.07 at between 270 nm and 300 nm.

Loss on drying <2.41> Not more than 0.5%. For the granulated powder, not more than 1.0% (1 g, 80°C, 2 hours).

Water <2.48> 4.5 – 5.5%. ◇For the granulated powder, 4.0 – 5.5%◇ (1 g, volumetric titration, direct titration. Use a mixture of methanol for water determination and formamide for water determination (2:1) instead of methanol for water determination).

Residue on ignition <2.44> Not more than 0.1% (1 g).

Microbial limit <4.05> The acceptance criteria of TAMC and TYMC are 10^2 CFU/g and 5×10^1 CFU/g, respectively. ◇*Salmonella* and ◇*Escherichia coli* are not observed.

◆**Containers and storage** Containers—Well-closed containers.◆

Lactulose

ラクツロース

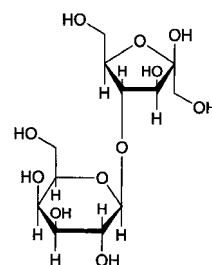

$C_{12}H_{22}O_{11}$: 342.30

β -D-Galactopyranosyl-(1→4)-D-fructose
[4618-18-2]

Lactulose is a solution of lactulose prepared by isomerizing lactose under the existing of alkaline and purified by ion-exchange resin.

It contains not less than 50.0% and not more than 56.0% of lactulose ($C_{12}H_{22}O_{11}$).

Description Lactulose occurs as a clear, colorless or light yellow, viscous liquid. It is odorless, and has a sweet taste.

It is miscible with water and with formamide.

Identification (1) To 0.7 g of Lactulose add 10 mL of water, 10 mL of a solution of hexaammonium heptamolybdate tetrahydrate (1 in 25) and 0.2 mL of acetic acid (100), and heat in a water bath for 5 to 10 minutes: a blue color develops.

(2) Mix 0.3 g of Lactulose and 30 mL of water, add 16 mL of 0.5 mol/L iodine TS, then immediately add 2.5 mL of 8 mol/L sodium hydroxide TS, allow to stand for 7 minutes, and add 2.5 mL of diluted sulfuric acid (3 in 20). To this solution add a saturated solution of sodium sulfite heptahydrate until the solution turns light yellow, then add 3 drops of methyl orange TS, neutralize with a solution of sodium hydroxide (4 in 25), and add water to make 100 mL. To 10 mL of this solution add 5 mL of Fehling's TS, and boil for 5 minutes: a red precipitate is produced.

pH <2.54> To 2.0 g of Lactulose add 15 mL of water: the pH of the solution is between 3.5 and 5.5.

Specific gravity <2.56> d_{20}^{20} : 1.320 – 1.360

Purity (1) Heavy metals <1.07>—Proceed with 5.0 g of Lactulose according to Method 4, and perform the test. Prepare the control solution with 2.5 mL of Standard Lead Solution (not more than 5 ppm).

(2) Arsenic <1.11>—Prepare the test solution with 1.0 g of Lactulose according to Method 1, and perform the test (not more than 2 ppm).

(3) Galactose and lactose—Determine the heights of the peaks corresponding to galactose and lactose respectively, on the chromatogram obtained in Assay from the sample solution and the standard solution, and calculate the ratios of the peak heights of galactose and lactose to that of the internal standard from the sample solution, Q_{Ta} and Q_{Tb} , and then from the standard solution, Q_{Sa} and Q_{Sb} : it contains galactose of not more than 11%, and lactose of not more than 6%.

$$\begin{aligned} &\text{Amount (mg) of galactose (C}_6\text{H}_{12}\text{O}_6) \\ &= M_S \times Q_{Ta}/Q_{Sa} \end{aligned}$$

M_S : Amount (mg) of galactose taken

$$\begin{aligned} & \text{Amount (mg) of lactose (C}_{12}\text{H}_{22}\text{O}_{11}\cdot\text{H}_2\text{O}) \\ & = M_S \times Q_{Tb}/Q_{Sb} \end{aligned}$$

M_S : Amount (mg) of lactose hydrate taken

Loss on drying <2.41> Not more than 35% (0.5 g, in vacuum, 80°C, 5 hours).

Residue on ignition <2.44> Not more than 0.1% (1 g).

Assay Weigh accurately about 1 g of Lactulose, add exactly 10 mL of the internal standard solution and water to make 50 mL, and use this solution as the sample solution. Separately, weigh accurately about 0.5 g of Lactulose RS, about 80 mg of D-galactose and about 40 mg of lactose monohydrate, add exactly 10 mL of the internal standard solution and water to make 50 mL, and use this solution as the standard solution. Perform the test with 20 μ L each of the sample solution and standard solution as directed under Liquid Chromatography <2.01> according to the following conditions, and calculate the ratios, Q_T and Q_S , of the peak height of lactulose to that of the internal standard.

$$\begin{aligned} & \text{Amount (mg) of lactulose (C}_{12}\text{H}_{22}\text{O}_{11}) \\ & = M_S \times Q_T/Q_S \end{aligned}$$

M_S : Amount (mg) of Lactulose RS taken

Internal standard solution—A solution of D-mannitol (1 in 20).

Operating conditions—

Detector: A differential refractometer.

Column: A stainless steel column 8 mm in inside diameter and 50 cm in length, packed with gel type strongly acidic ion-exchange resin for liquid chromatography (degree of crosslinkage: 6%) (11 μ m in particle diameter).

Column temperature: A constant temperature of about 75°C.

Mobile phase: Water.

Flow rate: Adjust so that the retention time of lactulose is about 18 minutes.

System suitability—

System performance: When the procedure is run with 10 μ L of the standard solution under the above operating conditions, lactulose and the internal standard are eluted in this order with the resolution between these peaks being not less than 8.

System repeatability: When the test is repeated 6 times with 20 μ L of the standard solution under the above operating conditions, the relative standard deviation of the ratios of the peak heights of lactulose, galactose and lactose to the height of the internal standard are not more than 2.0%, respectively.

Containers and storage Containers—Tight containers.

Lafutidine

ラフチジン

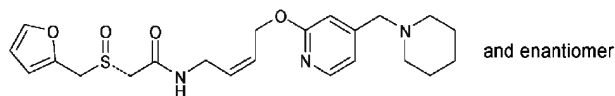

$\text{C}_{22}\text{H}_{29}\text{N}_3\text{O}_4\text{S}$: 431.55

2-[(*RS*)-Furan-2-ylmethylsulfinyl]-*N*-{4-[4-(piperidin-1-ylmethyl)pyridin-2-yl]oxy-(2*Z*)-but-2-en-1-yl]acetamide [206449-93-6]

Lafutidine, when dried, contains not less than 99.0% and not more than 101.0% of lafutidine ($\text{C}_{22}\text{H}_{29}\text{N}_3\text{O}_4\text{S}$).

Description Lafutidine occurs as a white to pale yellow-white crystalline powder.

It is freely soluble in acetic acid (100), soluble in methanol, sparingly soluble in ethanol (99.5), and practically insoluble in water.

A solution of Lafutidine in methanol (1 in 100) shows no optical rotation.

Lafutidine shows crystal polymorphism.

Identification (1) Determine the absorption spectrum of a solution of Lafutidine in methanol (1 in 20,000) as directed under Ultraviolet-visible Spectrophotometry <2.24>, and compare the spectrum with the Reference Spectrum: both spectra exhibit similar intensities of absorption at the same wavelengths.

(2) Determine the infrared absorption spectrum of Lafutidine, previously dried, as directed in the potassium bromide disk method under Infrared Spectrophotometry <2.25>, and compare the spectrum with the Reference Spectrum: both spectra exhibit similar intensities of absorption at the same wave numbers.

Purity (1) Heavy metals <1.07>—Proceed with 2.0 g of Lafutidine according to Method 2, and perform the test. Prepare the control solution with 2.0 mL of Standard Lead Solution (not more than 10 ppm).

(2) Related substances—Dissolve 0.10 g of Lafutidine in 100 mL of the mobile phase, and use this solution as the sample solution. Pipet 1 mL of the sample solution, add the mobile phase to make exactly 100 mL, and use this solution as the standard solution. Perform the test with exactly 5 μ L each of the sample solution and standard solution as directed under Liquid Chromatography <2.01> according to the following conditions. Determine each peak area by the automatic integration method: the area of the peak, having the relative retention time of about 0.85 to lafutidine, obtained from the sample solution is not larger than 3/10 times the peak area of lafutidine from the standard solution, the area of the peak other than lafutidine and the peak mentioned above from the sample solution is not larger than 1/10 times the peak area of lafutidine from the standard solution, and the total area of the peaks other than lafutidine from the sample solution is not larger than 2/5 times the peak area of lafutidine from the standard solution.

Operating conditions—

Detector: An ultraviolet absorption photometer (wavelength: 220 nm).

Column: A stainless steel column 6 mm in inside diameter and 15 cm in length, packed with octadecylsilanized silica gel for liquid chromatography (5 μ m in particle diameter).

Column temperature: A constant temperature of about 40°C.

Mobile phase: Dissolve 0.87 g of sodium 1-pentanesulfonate in 1000 mL of diluted phosphoric acid (1 in 1000). To 850 mL of this solution add 150 mL of acetonitrile.

Flow rate: Adjust so that the retention time of lafutidine is about 15 minutes.

Time span of measurement: About 6 times as long as the retention time of lafutidine.

System suitability—

Test for required detectability: To exactly 1 mL of the standard solution add the mobile phase to make exactly 20 mL. Confirm that the peak area of lafutidine obtained with 5 µL of this solution is equivalent to 3.5 to 6.5% of that with 5 µL of the standard solution.

System performance: When the procedure is run with 5 µL of the standard solution under the above operating conditions, the number of theoretical plates and the symmetry factor of the peak of lafutidine are not less than 8000 and not more than 1.5, respectively.

System repeatability: When the test is repeated 6 times with 5 µL of the standard solution under the above operating conditions, the relative standard deviation of the peak area of lafutidine is not more than 2.0%.

Loss on drying <2.41> Not more than 0.5% (1 g, reduced pressure not exceeding 0.67 kPa, phosphorus (V) oxide, 4 hours).

Residue on ignition <2.44> Not more than 0.1% (1 g).

Assay Weigh accurately about 0.3 g of Lafutidine, previously dried, dissolve in 50 mL of acetic acid (100), and titrate <2.50> with 0.1 mol/L perchloric acid VS (potentiometric titration). Perform a blank determination in the same manner, and make any necessary correction.

Each mL of 0.1 mol/L perchloric acid VS
= 21.58 mg of C₂₂H₂₉N₃O₄S

Containers and storage Containers—Tight containers.

Lafutidine Tablets

ラフチジン錠

Lafutidine Tablets contain not less than 95.0% and not more than 105.0% of the labeled amount of lafutidine (C₂₂H₂₉N₃O₄S: 431.55).

Method of preparation Prepare as directed under Tablets, with Lafutidine.

Identification Powder Lafutidine Tablets. To a portion of the powder, equivalent to 10 mg of Lafutidine, add 10 mL of methanol, shake thoroughly, and centrifuge. To 5 mL of the supernatant liquid add methanol to make 100 mL. Determine the absorption spectrum of this solution as directed under Ultraviolet-visible Spectrophotometry <2.24>: it exhibits an absorption maximum between 271 nm and 275 nm.

Purity Related substances—To 10 Lafutidine Tablets add 4V/5 mL of the mobile phase, disintegrate the tablets by sonicating, then shake vigorously for not less than 30 minutes, and add the mobile phase to make V mL so that each mL contains about 1 mg of lafutidine (C₂₂H₂₉N₃O₄S). Centrifuge, and use the supernatant liquid as the sample solution. Pipet 1 mL of the sample solution, add the mobile phase to make exactly 100 mL, and use this solution as the

standard solution. Perform the test with exactly 5 µL each of the sample solution and standard solution as directed under Liquid Chromatography <2.01> according to the following conditions, and determine each peak area by the automatic integration method: the area of the peak, other than lafutidine and the peak having the relative retention time of about 0.85 to lafutidine, obtained from the sample solution is not larger than 1/5 times the peak area of lafutidine from the standard solution, and the total area of the peaks, other than lafutidine and the peak having the relative retention time of about 0.85, from the sample solution is not larger than 3/5 times the peak area of lafutidine from the standard solution.

Operating conditions—

Column, column temperature, mobile phase, and flow rate: Proceed as directed in the operating conditions in the Assay.

Detector: An ultraviolet absorption photometer (wavelength: 220 nm).

Time span of measurement: About 6 times as long as the retention time of lafutidine.

System suitability—

Test for required detectability: To exactly 1 mL of the standard solution add the mobile phase to make exactly 20 mL. Confirm that the peak area of lafutidine obtained with 5 µL of this solution is equivalent to 3.5 to 6.5% of that with 5 µL of the standard solution.

System performance: When the procedure is run with 5 µL of the standard solution under the above operating conditions, the number of theoretical plates and the symmetry factor of the peak of lafutidine are not less than 8000 and not more than 1.5, respectively.

System repeatability: When the test is repeated 6 times with 5 µL of the standard solution under the above operating conditions, the relative standard deviation of the peak area of lafutidine is not more than 2.0%.

Uniformity of dosage units <6.02> Perform the test according to the following method: it meets the requirement of the Content uniformity test.

To 1 tablet of Lafutidine Tablets add exactly V mL of the internal standard solution so that each mL contains about 2 mg of lafutidine (C₂₂H₂₉N₃O₄S), disintegrate the tablet by sonicating, then shake vigorously for 30 minutes. Centrifuge this solution, filter the supernatant liquid through a membrane filter with a pore size not exceeding 0.45 µm, and use the filtrate as the sample solution. Separately, weigh accurately about 0.1 g of lafutidine for assay, previously dried under a reduced pressure (not exceeding 0.67 kPa) using phosphorus (V) oxide as desiccant for 4 hours, dissolve in exactly 50 mL of the internal standard solution, and use this solution as the standard solution. Then, proceed as directed in the Assay.

$$\begin{aligned} &\text{Amount (mg) of lafutidine (C}_{22}\text{H}_{29}\text{N}_3\text{O}_4\text{S)} \\ &= M_S \times Q_T / Q_S \times V / 50 \end{aligned}$$

M_S : Amount (mg) of lafutidine for assay taken

Internal standard solution—A solution of ethyl aminobenzoate in a mixture of acetonitrile and water (4:1) (3 in 10,000).

Dissolution <6.10> When the test is performed at 50 revolutions per minute according to the Paddle method, using 900 mL of 2nd fluid for dissolution test as the dissolution medium, the dissolution rate in 15 minutes of Lafutidine Tablets is not less than 75%.

Start the test with 1 tablet of Lafutidine Tablets, withdraw not less than 20 mL of the medium at the specified minute after starting the test, and filter through a membrane filter

with a pore size not exceeding $0.45\ \mu\text{m}$. Discard not less than 10 mL of the first filtrate, pipet V mL of the subsequent filtrate, add the dissolution medium to make exactly V' mL so that each mL contains about $5.6\ \mu\text{g}$ of lafutidine ($\text{C}_{22}\text{H}_{29}\text{N}_3\text{O}_4\text{S}$), and use this solution as the sample solution. Separately, weigh accurately about 25 mg of lafutidine for assay, previously dried under a reduced pressure (not exceeding 0.67 kPa) using phosphorus (V) oxide as desiccant for 4 hours, and dissolve in the dissolution medium to make exactly 100 mL. Pipet 2 mL of this solution, add the dissolution medium to make exactly 100 mL, and use this solution as the standard solution. Perform the test with exactly $25\ \mu\text{L}$ each of the sample solution and standard solution as directed under Liquid Chromatography <2.01> according to the following conditions, and determine the peak areas, A_T and A_S , of lafutidine in each solution.

$$\begin{aligned} & \text{Dissolution rate (\%)} \text{ with respect to the labeled amount} \\ & \text{of lafutidine } (\text{C}_{22}\text{H}_{29}\text{N}_3\text{O}_4\text{S}) \\ & = M_S \times A_T / A_S \times V' / V \times 1 / C \times 18 \end{aligned}$$

M_S : Amount (mg) of lafutidine for assay taken

C : Labeled amount (mg) of lafutidine ($\text{C}_{22}\text{H}_{29}\text{N}_3\text{O}_4\text{S}$) in 1 tablet

Operating conditions—

Proceed as directed in the operating conditions in the Assay.

System suitability—

System performance: When the procedure is run with 25 μL of the standard solution under the above operating conditions, the number of theoretical plates and the symmetry factor of the peak of lafutidine are not less than 7000 and not more than 1.5, respectively.

System repeatability: When the test is repeated 6 times with 25 μL of the standard solution under the above operating conditions, the relative standard deviation of the peak area of lafutidine is not more than 2.0%.

Assay To 20 Lanoconazole Tablets add 4V/5 mL of the internal standard solution, disintegrate the tablets with the aid of ultrasonic waves, then shake vigorously for 30 minutes. Add the internal standard solution to make exactly V mL so that each mL contains about 2 mg of lafutidine ($\text{C}_{22}\text{H}_{29}\text{N}_3\text{O}_4\text{S}$), centrifuge, filter the supernatant liquid through a membrane filter with a pore size not exceeding $0.45\ \mu\text{m}$, and use the filtrate as the sample solution. Separately, weigh accurately about 0.1 g of lafutidine for assay, previously dried under a reduced pressure (not exceeding 0.67 kPa) using phosphorus (V) oxide as desiccant for 4 hours, dissolve in the internal standard solution to make exactly 50 mL, and use this solution as the standard solution. Perform the test with 5 μL each of the sample solution and standard solution as directed under Liquid Chromatography <2.01> according to the following conditions, and calculate the ratios, Q_T and Q_S , of the peak area of lafutidine to that of the internal standard.

$$\begin{aligned} & \text{Amount (mg) of lafutidine } (\text{C}_{22}\text{H}_{29}\text{N}_3\text{O}_4\text{S}) \text{ in 1 tablet} \\ & = M_S \times Q_T / Q_S \times V / 1000 \end{aligned}$$

M_S : Amount (mg) of lafutidine for assay taken

Internal standard solution—A solution of ethyl aminobenzoate in a mixture of acetonitrile and water (4:1) (3 in 10,000).

Operating conditions—

Detector: An ultraviolet absorption photometer (wavelength: 275 nm).

Column: A stainless steel column 6 mm in inside diameter and 15 cm in length, packed with octadecylsilanized silica gel for liquid chromatography ($5\ \mu\text{m}$ in particle diameter).

Column temperature: A constant temperature of about 40°C .

Mobile phase: Dissolve 0.87 g of sodium 1-pentanesulfonate in 1000 mL of diluted phosphoric acid (1 in 1000). To 850 mL of this solution add 150 mL of acetonitrile.

Flow rate: Adjust so that the retention time of lafutidine is about 15 minutes.

System suitability—

System performance: When the procedure is run with 5 μL of the standard solution under the above operating conditions, lafutidine and the internal standard are eluted in this order with the resolution between these peaks being not less than 6.

System repeatability: When the test is repeated 6 times with 5 μL of the standard solution under the above operating conditions, the relative standard deviation of the ratio of the peak area of lafutidine to that of the internal standard is not more than 1.0%.

Containers and storage Containers—Tight containers.

Lanoconazole

ラノコナゾール

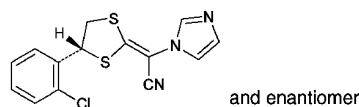

$\text{C}_{14}\text{H}_{10}\text{ClN}_3\text{S}_2$: 319.83

(2*E*)-2-[(4*R*S)-4-(2-Chlorophenyl)-1,3-dithiolan-2-ylidene]-2-(1*H*-imidazol-1-yl)acetonitrile
[101530-10-3]

Lanoconazole, when dried, contains not less than 98.0% and not more than 102.0% of lanoconazole ($\text{C}_{14}\text{H}_{10}\text{ClN}_3\text{S}_2$).

Description Lanoconazole occurs as white to pale yellow, crystals or crystalline powder.

It is soluble in acetone, sparingly soluble in methanol and in ethanol (99.5), and practically insoluble in water.

It is gradually colored to yellow by light.

A solution of Lanoconazole in acetone (1 in 25) shows no optical rotation.

Identification (1) To 0.1 g of Lanoconazole add 0.5 g of sodium hydroxide, heat gradually to melt, and carbonize. After cooling, add 10 mL of dilute hydrochloric acid: the gas evolved darkens moistened lead (II) acetate paper.

(2) Perform the test with Lanoconazole as directed under Flame Coloration Test <1.04> (2): a green color appears.

(3) Determine the absorption spectrum of a solution of Lanoconazole in methanol (1 in 100,000) as directed under Ultraviolet-visible Spectrophotometry <2.24>, and compare the spectrum with the Reference Spectrum or the spectrum of a solution of Lanoconazole RS prepared in the same manner as the sample solution: both spectra exhibit similar intensities of absorption at the same wavelengths.

(4) Determine the infrared absorption spectrum of Lanoconazole, previously dried, as directed in the potassium bromide disk method under Infrared Spectrophotometry <2.25>, and compare the spectrum with the Reference Spectrum or the spectrum of previously dried Lanoconazole RS: both spectra exhibit similar intensities of absorption at the same wave numbers.

Melting point <2.60> 141 – 146°C

Purity (1) Heavy metals <1.07>—Proceed with 2.0 g of Lanocanazole according to Method 4, and perform the test. Prepare the control solution with 2.0 mL of Standard Lead Solution (not more than 10 ppm).

(2) Related substances—Conduct this procedure using light-resistant vessels. Dissolve 0.10 g of Lanocanazole in 100 mL of methanol, and use this solution as the sample solution. Pipet 1 mL of the sample solution, add methanol to make exactly 50 mL, and use this solution as the standard solution. Perform the test with exactly 5 μ L each of the sample solution and standard solution as directed under Liquid Chromatography <2.01> according to the following conditions. Determine each peak area by the automatic integration method: the total area of the peaks other than lanocanazole obtained from the sample solution is not larger than 1/2 times the peak area of lanocanazole from the standard solution.

Operating conditions—

Detector, column, and column temperature: Proceed as directed in the operating conditions in the Assay.

Mobile phase: Dissolve 0.576 g of sodium 1-nonanesulfonate in 1000 mL of a mixture of methanol, water and acetic acid (100) (55:44:1).

Flow rate: Adjust so that the retention time of lanocanazole is about 7 minutes.

Time span of measurement: About 3 times as long as the retention time of lanocanazole, beginning after the solvent peak.

System suitability—

Test for required detectability: Pipet 2.5 mL of the standard solution, and add methanol to make exactly 50 mL. Confirm that the peak area of lanocanazole obtained with 5 μ L of this solution is equivalent to 3.5 to 6.5% of that with 5 μ L of the standard solution.

System performance: Put 20 mL of the sample solution in a colorless vessel, and expose to ultraviolet light (main wavelength: 365 nm) for 30 minutes. When the procedure is run with 5 μ L of this solution under the above operating conditions, the resolution between the peak having the relative retention time of about 0.8 to lanocanazole and the peak of lanocanazole is not less than 1.5.

System repeatability: When the test is repeated 6 times with 5 μ L of the standard solution under the above operating conditions, the relative standard deviation of the peak area of lanocanazole is not more than 1.0%.

Loss on drying <2.41> Not more than 0.4% (1 g, 105°C, 2 hours).

Residue on ignition <2.44> Not more than 0.1% (1 g).

Assay Conduct this procedure using light-resistant vessels. Weigh accurately about 50 mg each of Lanocanazole and Lanocanazole RS, both previously dried, and dissolve each in methanol to make exactly 50 mL. Pipet 5 mL each of these solutions, add exactly 5 mL of the internal standard solution, add methanol to make 50 mL, and use these solutions as the sample solution and the standard solution, respectively. Perform the test with 5 μ L each of the sample solution and standard solution as directed under Liquid Chromatography <2.01> according to the following conditions, and calculate the ratios, Q_T and Q_S , of the peak area of lanocanazole to that of the internal standard.

$$\begin{aligned} &\text{Amount (mg) of lanocanazole (C}_{14}\text{H}_{10}\text{ClN}_3\text{S}_2) \\ &= M_S \times Q_T / Q_S \end{aligned}$$

M_S : Amount (mg) of Lanocanazole RS taken

Internal standard solution—A solution of diisopropyl 1,3-

dithiolan-2-ylidenemalonate in methanol (1 in 1000).

Operating conditions—

Detector: An ultraviolet absorption photometer (wavelength: 295 nm).

Column: A stainless steel column 4.6 mm in inside diameter and 15 cm in length, packed with octadecylsilanized silica gel for liquid chromatography (5 μ m in particle diameter).

Column temperature: A constant temperature of about 50°C.

Mobile phase: A mixture of methanol and water (11:9).

Flow rate: Adjust so that the retention time of lanocanazole is about 9 minutes.

System suitability—

System performance: When the procedure is run with 5 μ L of the standard solution under the above operating conditions, lanocanazole and the internal standard are eluted in this order with the resolution between these peaks being not less than 3.

System repeatability: When the test is repeated 6 times with 5 μ L of the standard solution under the above operating conditions, the relative standard deviation of the ratio of the peak area of lanocanazole to that of the internal standard is not more than 1.0%.

Containers and storage Containers—Well-closed containers.

Storage—Light-resistant.

Lanocanazole Cream

ラノコナゾールクリーム

Lanocanazole Cream contains not less than 95.0% and not more than 105.0% of the labeled amount of lanocanazole (C₁₄H₁₀ClN₃S₂; 319.83).

Method of preparation Prepare as directed under Creams, with Lanocanazole.

Identification Warm Lanocanazole Cream to soften, if necessary. To a quantity of Lanocanazole Cream, equivalent to 50 mg of Lanocanazole, add 10 mL of diluted hydrochloric acid (1 in 6) saturated with sodium chloride, previously warmed, shake vigorously for 15 minutes to disperse, and centrifuge. Filter the supernatant liquid, wash the residue with 1.5 mL of diluted hydrochloric acid (1 in 6) saturated with sodium chloride, filter, and combine the washing with the filtrate. To the combined filtrate add 2.5 g of sodium hydrogen carbonate to dissolve, and extract with 10 mL of diethyl ether. Wash the diethyl ether layer with three 10-mL portions of water, and dry under reduced pressure. Dissolve the residue in 15 mL of acetone, and use this solution as the sample solution. Separately, dissolve 10 mg of lanocanazole in 10 mL of acetone, and use this solution as the standard solution. Perform the test with these solutions as directed under Thin-layer Chromatography <2.03>. Spot 10 μ L each of the sample solution and standard solution on a plate of silica gel with fluorescent indicator for thin-layer chromatography. Develop the plate with a mixture of ethyl acetate, toluene, methanol and ammonia solution (28) (400:400:20:1) to a distance of about 15 cm, and air-dry the plate. Examine under ultraviolet light (main wavelength: 254 nm): the principal spot obtained from the sample solution and the spot from the standard solution show the same R_f value.

Assay Conduct this procedure using light-resistant vessels. Weigh accurately a quantity of Lanocanazole Cream,

equivalent to about 15 mg of lanconazole ($C_{14}H_{10}ClN_3S_2$), add 80 mL of methanol, sonicate to disperse, and add exactly 10 mL of the internal standard solution. Add methanol to make 100 mL, filter through a membrane filter with a pore size of 0.45 μ m if necessary, and use this solution as the sample solution. Separately, weigh accurately about 15 mg of Lanconazole RS, previously dried at 105°C for 2 hours, dissolve in methanol, and add exactly 10 mL of the internal standard solution. Add methanol to make 100 mL, and use this solution as the standard solution. Perform the test with 10 μ L each of the sample solution and standard solution as directed under Liquid Chromatography <2.01> according to the following conditions, and calculate the ratios, Q_T and Q_S , of the peak area of lanconazole to that of the internal standard.

$$\begin{aligned} &\text{Amount (mg) of lanconazole (C}_{14}\text{H}_{10}\text{ClN}_3\text{S}_2\text{)} \\ &= M_S \times Q_T/Q_S \end{aligned}$$

M_S : Amount (mg) of Lanconazole RS taken

Internal standard solution—A solution of diisopropyl 1,3-dithiolan-2-ylidenemalonate in methanol (1 in 1000).

Operating conditions—

Proceed as directed in the operating conditions in the Assay under Lanconazole.

System suitability—

System performance: When the procedure is run with 10 μ L of the standard solution under the above operating conditions, lanconazole and the internal standard are eluted in this order with the resolution between these peaks being not less than 3.

System repeatability: When the test is repeated 6 times with 10 μ L of the standard solution under the above operating conditions, the relative standard deviation of the ratio of the peak area of lanconazole to that of the internal standard is not more than 1.0%.

Containers and storage Containers—Tight containers.

Storage—Light-resistant.

Lanconazole Cutaneous Solution

ラノコナゾール外用液

Lanconazole Cutaneous Solution is a liquid for external use.

It contains not less than 95.0% and not more than 105.0% of the labeled amount of lanconazole ($C_{14}H_{10}ClN_3S_2$; 319.83).

Method of preparation Prepare as directed under Liquids and Solutions for Cutaneous Application, with Lanconazole.

Identification To a volume of Lanconazole Cutaneous Solution, equivalent to 50 mg of Lanconazole, add water enough to produce precipitate, and shake vigorously. Filter this solution, rinse the vessel with a suitable amount of water, and collect the precipitates. Wash the precipitates with 100 mL of water, dissolve in acetone, and dry under reduced pressure. If there are water droplets in the residue, dissolve the residue in 40 mL of acetone, and dry again under reduced pressure. Dissolve the residue in 30 mL of acetone, and use this solution as the sample solution. Separately, dissolve 10 mg of lanconazole in 10 mL of acetone, and use this solution as the standard solution. Perform the test with these solutions as directed under Thin-layer Chromatography <2.03>.

Spot 10 μ L each of the sample solution and standard solution on a plate of silica gel with fluorescent indicator for thin-layer chromatography. Develop the plate with a mixture of ethyl acetate, toluene, methanol and ammonia solution (28) (400:400:20:1) to a distance of about 15 cm, and air-dry the plate. Examine under ultraviolet light (main wavelength: 254 nm): the principal spot obtained from the sample solution and the spot from the standard solution show the same R_f value.

Assay Conduct this procedure using light-resistant vessels. Pipet a volume of Lanconazole Cutaneous Solution, equivalent to about 50 mg of lanconazole ($C_{14}H_{10}ClN_3S_2$), and add methanol to make exactly 50 mL. Pipet 15 mL of this solution, add exactly 10 mL of the internal standard solution, add methanol to make 100 mL, and use this solution as the sample solution. Separately, weigh accurately about 15 mg of Lanconazole RS, previously dried at 105°C for 2 hours, dissolve in methanol, and add exactly 10 mL of the internal standard solution. Add methanol to make 100 mL, and use this solution as the standard solution. Perform the test with 10 μ L each of the sample solution and standard solution as directed under Liquid Chromatography <2.01> according to the following conditions, and calculate the ratios, Q_T and Q_S , of the peak area of lanconazole to that of the internal standard.

$$\begin{aligned} &\text{Amount (mg) of lanconazole (C}_{14}\text{H}_{10}\text{ClN}_3\text{S}_2\text{)} \\ &= M_S \times Q_T/Q_S \times 10/3 \end{aligned}$$

M_S : Amount (mg) of Lanconazole RS taken

Internal standard solution—A solution of diisopropyl 1,3-dithiolan-2-ylidenemalonate in methanol (1 in 1000).

Operating conditions—

Proceed as directed in the operating conditions in the Assay under Lanconazole.

System suitability—

System performance: When the procedure is run with 10 μ L of the standard solution under the above operating conditions, lanconazole and the internal standard are eluted in this order with the resolution between these peaks being not less than 3.

System repeatability: When the test is repeated 6 times with 10 μ L of the standard solution under the above operating conditions, the relative standard deviation of the ratio of the peak area of lanconazole to that of the internal standard is not more than 1.0%.

Containers and storage Containers—Tight containers.

Storage—Light-resistant.

Lanconazole Ointment

ラノコナゾール軟膏

Lanconazole Ointment contains not less than 93.0% and not more than 107.0% of the labeled amount of lanconazole ($C_{14}H_{10}ClN_3S_2$; 319.83).

Method of preparation Prepare as directed under Ointments, with Lanconazole.

Identification To a quantity of Lanconazole Ointment, equivalent to 50 mg of Lanconazole, add 15 mL of hexane, sonicate to disperse, add 10 mL of methanol, and shake for 10 minutes. Centrifuge this solution, discard the hexane layer, and take the methanol layer. Wash the residue with a small amount of methanol if necessary, and combine the

washing with the methanol layer. Dry the combined methanol layer under reduced pressure, dissolve the residue in 40 mL of acetone, and use this solution as the sample solution. Separately, dissolve 10 mg of lanoconazole in 10 mL of acetone, and use this solution as the standard solution. Perform the test with these solutions as directed under Thin-layer Chromatography <2.03>. Spot 10 μ L each of the sample solution and standard solution on a plate of silica gel with fluorescent indicator for thin-layer chromatography. Develop the plate with a mixture of ethyl acetate, toluene, methanol and ammonia solution (28) (400:400:20:1) to a distance of about 15 cm, and air-dry the plate. Examine under ultraviolet light (main wavelength: 254 nm): the principal spot obtained from the sample solution and the spot from the standard solution show the same *R_f* value.

Assay Conduct this procedure using light-resistant vessels. Weigh accurately a quantity of Lanoconazole Ointment, equivalent to about 15 mg of lanoconazole ($C_{14}H_{10}ClN_3S_2$), add 20 mL of tetrahydrofuran, sonicate to disperse, and add exactly 10 mL of the internal standard solution. Add methanol to make 100 mL, and use this solution as the sample solution. Separately, weigh accurately about 15 mg of Lanoconazole RS, previously dried at 105°C for 2 hours, dissolve in methanol, and add exactly 10 mL of the internal standard solution. Add methanol to make 100 mL, and use this solution as the standard solution. Perform the test with 10 μ L each of the sample solution and standard solution as directed under Liquid Chromatography <2.01> according to the following conditions, and calculate the ratios, Q_T and Q_S , of the peak area of lanoconazole to that of the internal standard.

$$\begin{aligned} \text{Amount (mg) of lanoconazole (C}_{14}\text{H}_{10}\text{ClN}_3\text{S}_2) \\ = M_S \times Q_T/Q_S \end{aligned}$$

M_S : Amount (mg) of Lanoconazole RS taken

Internal standard solution—A solution of diisopropyl 1,3-dithiolan-2-ylidenemalonate in methanol (1 in 1000).

Operating conditions—

Proceed as directed in the operating conditions in the Assay under Lanoconazole.

System suitability—

System performance: When the procedure is run with 10 μ L of the standard solution under the above operating conditions, lanoconazole and the internal standard are eluted in this order with the resolution between these peaks being not less than 3.

System repeatability: When the test is repeated 6 times with 10 μ L of the standard solution under the above operating conditions, the relative standard deviation of the ratio of the peak area of lanoconazole to that of the internal standard is not more than 1.0%.

Containers and storage Containers—Tight containers.

Storage—Light-resistant.

Lansoprazole

ランソプラゾール

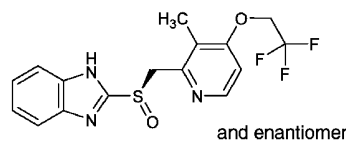

$C_{16}H_{14}F_3N_3O_2S$: 369.36

(*RS*)-2-([3-Methyl-4-(2,2,2-trifluoroethoxy)pyridin-2-yl]methyl)sulfinyl]-1*H*-benzimidazole [103577-45-3]

Lansoprazole contains not less than 99.0% and not more than 101.0% of lansoprazole ($C_{16}H_{14}F_3N_3O_2S$), calculated on the anhydrous basis.

Description Lansoprazole occurs as a white to brownish white crystalline powder.

It is freely soluble in *N,N*-dimethylformamide, soluble in methanol, sparingly soluble in ethanol (99.5), and practically insoluble in water.

A solution of Lansoprazole in *N,N*-dimethylformamide (1 in 10) shows no optical rotation.

Melting point: about 166°C (with decomposition).

It shows crystal polymorphism.

Identification (1) Determine the absorption spectrum of a solution of Lansoprazole in methanol (1 in 100,000) as directed under Ultraviolet-visible Spectrophotometry <2.24>, and compare the spectrum with the Reference Spectrum or the spectrum of a solution of Lansoprazole RS prepared in the same manner as the sample solution: both spectra exhibit similar intensities of absorption at the same wavelengths.

(2) Determine the infrared absorption spectrum of Lansoprazole as directed in the potassium bromide disk method under Infrared Spectrophotometry <2.25>, and compare the spectrum with the Reference Spectrum or the spectrum of Lansoprazole RS: both spectra exhibit similar intensities of absorption at the same wave numbers.

Purity (1) Clarity and color of solution—Dissolve 1.0 g of Lansoprazole in 20 mL of *N,N*-dimethylformamide: the solution is clear and not more colored than Matching Fluid G.

(2) Heavy metals <1.07>—Proceed with 1.0 g of Lansoprazole in a platinum crucible according to Method 2, and perform the test. Prepare the control solution with 1.0 mL of Standard Lead Solution (not more than 10 ppm).

(3) Arsenic <1.11>—Prepare the test solution with 1.0 g of Lansoprazole in a platinum crucible according to Method 3, using a solution of magnesium nitrate hexahydrate in ethanol (95) (1 in 5), and perform the test. Prepare the standard color with 1.0 mL of Standard Arsenic Solution (not more than 1 ppm).

(4) Related substances—Dissolve 50 mg of Lansoprazole in a mixture of dilute sodium hydroxide TS and methanol (3:1) to make 20 mL. To 2 mL of this solution add a mixture of dilute sodium hydroxide TS and methanol (3:1) to make 20 mL, and use this solution as the sample solution. Pipet 1 mL of the sample solution, add a mixture of dilute sodium hydroxide TS and methanol (3:1) to make exactly 100 mL, and use this solution as the standard solution. Perform the test with exactly 40 μ L each of the sample solution and standard solution as directed under Liquid Chromatography <2.01> according to the following conditions, and determine

each peak area by the automatic integration method: the area of the peak, having a relative retention time of about 1.1 to lansoprazole, obtained from the sample solution is not larger than 2/5 times the peak area of lansoprazole from the standard solution, and the area of the peak other than lansoprazole and the peaks mentioned above from the sample solution is not larger than 1/10 times the peak area of lansoprazole from the standard solution. Furthermore, the total area of the peaks other than lansoprazole from the sample solution is not larger than 3/5 times the peak area of lansoprazole from the standard solution. For the area of the peaks, having the relative retention time of about 0.8, about 1.1 and about 1.2, multiply their correction factors, 0.8, 1.2, and 1.3, respectively.

Operating conditions—

Detector: An ultraviolet absorption photometer (wavelength: 285 nm).

Column: A stainless steel column 4.6 mm in inside diameter and 15 cm in length, packed with octadecylsilylated silica gel for liquid chromatography (5 μm in particle diameter).

Column temperature: A constant temperature of about 25°C.

Mobile phase A: Water.

Mobile phase B: A mixture of acetonitrile, water and triethylamine (160:40:1), adjusted to pH 7.0 with phosphoric acid.

Flowing of mobile phase: Control the gradient by mixing the mobile phases A and B as directed in the following table.

Time after injection of sample (min)	Mobile phase A (vol%)	Mobile phase B (vol%)
0 – 40	90 → 20	10 → 80
40 – 50	20	80

Flow rate: About 0.8 mL per minute (the retention time of lansoprazole is about 29 minutes).

Time span of measurement: About 1.7 times as long as the retention time of lansoprazole.

System suitability—

Test for required detectability: Pipet 1 mL of the standard solution, and add a mixture of dilute sodium hydroxide TS and methanol (3:1) to make exactly 20 mL. Confirm that the peak area of lansoprazole obtained with 40 μL of this solution is equivalent to 4% to 6% of that with 40 μL of the standard solution.

System performance: When the procedure is run with 40 μL of the standard solution under the above operating conditions, the number of theoretical plates and the symmetry factor of the peak of lansoprazole are not less than 150,000 and not more than 1.5, respectively.

System repeatability: When the test is repeated 6 times with 40 μL of the standard solution under the above operating conditions, the relative standard deviation of the peak area of lansoprazole is not more than 3.0%.

Water <2.48> Not more than 0.10% (0.5 g, coulometric titration).

Residue on ignition <2.44> Not more than 0.1% (1 g, platinum crucible).

Assay Weigh accurately about 50 mg each of Lansoprazole and Lansoprazole RS (separately determine the water <2.48> in the same manner as Lansoprazole), and dissolve each in exactly 10 mL of the internal standard solution. To 1 mL each of both solutions add diluting solution to make 50 mL, and use these solutions as the sample solution and the stand-

ard solution, respectively. Perform the test with 10 μL each of the sample solution and standard solution as directed under Liquid Chromatography <2.01> according to the following conditions, and calculate the ratios, Q_T and Q_S , of the peak area of lansoprazole to that of the internal standard.

$$\begin{aligned} &\text{Amount (mg) of lansoprazole (C}_{16}\text{H}_{14}\text{F}_3\text{N}_3\text{O}_2\text{S)} \\ &= M_S \times Q_T/Q_S \end{aligned}$$

M_S : Amount (mg) of Lansoprazole RS taken, calculated on the anhydrous basis

Internal standard solution—A solution of 4'-ethoxyacetophenone in diluting solution (1 in 400).

Diluting solution: A mixture of water, acetonitrile and triethylamine (60:40:1), adjusted to pH 11.0 with phosphoric acid.

Operating conditions—

Detector: An ultraviolet absorption photometer (wavelength: 285 nm).

Column: A stainless steel column 4.6 mm in inside diameter and 25 cm in length, packed with octadecylsilylated silicon polymer coated silica gel for liquid chromatography (5 μm in particle diameter).

Column temperature: A constant temperature of about 25°C.

Mobile phase: A mixture of water, acetonitrile and triethylamine (60:40:1), adjusted to pH 7.0 with phosphoric acid.

Flow rate: Adjust so that the retention time of lansoprazole is about 7 minutes.

System suitability—

System performance: When the procedure is run with 10 μL of the standard solution under the above operating conditions, lansoprazole and the internal standard are eluted in this order with the resolution between these peaks being not less than 10.

System repeatability: When the test is repeated 6 times with 10 μL of the standard solution under the above operating conditions, the relative standard deviation of the ratio of the peak area of lansoprazole to that of the internal standard is not more than 1.0%.

Containers and storage Containers—Tight containers.

Storage—Light-resistant.

Lansoprazole Delayed-release Capsules

ランソプラゾール腸溶カプセル

Lansoprazole Delayed-release Capsules contain not less than 95.0% and not more than 105.0% of the labeled amount of lansoprazole (C₁₆H₁₄F₃N₃O₂S: 369.36).

Method of preparation Prepare as directed under Capsules, with Lansoprazole.

Identification Take out the contents of Lansoprazole Delayed-release Capsules, and powder. To a portion of the powder, equivalent to 5 mg of Lansoprazole, add 5 mL of methanol, shake thoroughly, and centrifuge. To 0.1 mL of the supernatant liquid add 10 mL of methanol, and determine the absorption spectrum of this solution as directed under Ultraviolet-visible Spectrophotometry <2.24>: it exhibits a maximum between 282 nm and 286 nm.

Uniformity of dosage units <6.02> Perform the test according to the following method: it meets the requirement of the Content uniformity test.

Take out the contents of 1 capsule of Lansoprazole Delayed-release Capsules, add 3V/10 mL of dilute sodium hydroxide TS, and sonicate with occasional stirring to disintegrate the contents completely. Add acetonitrile to make exactly V mL so that each mL contains about 0.15 mg of lansoprazole (C₁₆H₁₄F₃N₃O₂S). Centrifuge this solution, filter the supernatant liquid through a membrane filter with a pore size not exceeding 0.5 μm. Discard the first 5 mL of the filtrate, pipet 4 mL of the subsequent filtrate, add a mixture of acetonitrile and dilute sodium hydroxide TS (7:3) to make exactly 50 mL, and use this solution as the sample solution. Separately, weigh accurately about 30 mg of Lansoprazole RS (separately determine the water <2.48> in the same manner as Lansoprazole), and dissolve in 60 mL of dilute sodium hydroxide TS, and add acetonitrile to make exactly 200 mL. Pipet 4 mL of this solution, add a mixture of acetonitrile and dilute sodium hydroxide TS (7:3) to make exactly 50 mL, and use this solution as the standard solution. Determine the absorbances, A_T and A_S, at 294 nm of the sample solution and standard solution as directed under Ultraviolet-visible Spectrophotometry <2.24>.

$$\begin{aligned} &\text{Amount (mg) of lansoprazole (C}_{16}\text{H}_{14}\text{F}_3\text{N}_3\text{O}_2\text{S)} \\ &= M_S \times A_T/A_S \times V/200 \end{aligned}$$

M_S: Amount (mg) of Lansoprazole RS taken, calculated on the anhydrous basis

Dissolution Being specified separately when the drug is granted approval based on the Law.

Assay Take out the contents of not less than 20 capsules of Lansoprazole Delayed-release Capsules. Weigh accurately the mass of the contents, and powder. Weigh accurately a portion of the powder, equivalent to about 0.3 g of lansoprazole (C₁₆H₁₄F₃N₃O₂S), add 60 mL of dilute sodium hydroxide TS, sonicate, and shake thoroughly. To this solution add 20 mL of acetonitrile and exactly 20 mL of the internal standard solution, shake thoroughly, and centrifuge. To 1 mL of the supernatant liquid add diluting solution to make 30 mL, and filter through a membrane filter with a pore size not exceeding 0.5 μm. Discard not less than 5 mL of the first filtrate, and use the subsequent filtrate as the sample solution. Separately, weigh accurately about 30 mg of Lansoprazole RS (separately determine the water <2.48> in the same manner as Lansoprazole), dissolve in 6 mL of dilute sodium hydroxide TS and 2 mL of acetonitrile, and add exactly 2 mL of the internal standard solution. To 1 mL of this solution add diluting solution to make 30 mL, and use this solution as the standard solution. Perform the test with 10 μL each of the sample solution and standard solution as directed under Liquid Chromatography <2.01> according to the following conditions, and calculate the ratios, Q_T and Q_S, of the peak area of lansoprazole to that of the internal standard.

$$\begin{aligned} &\text{Amount (mg) of lansoprazole (C}_{16}\text{H}_{14}\text{F}_3\text{N}_3\text{O}_2\text{S)} \\ &= M_S \times Q_T/Q_S \times 10 \end{aligned}$$

M_S: Amount (mg) of Lansoprazole RS taken, calculated on the anhydrous basis

Internal standard solution—A solution of 4'-ethoxyacetophenone in acetonitrile (3 in 400).

Diluting solution: A mixture of water, acetonitrile and triethylamine (60:40:1), adjusted to pH 11.0 with phosphoric acid.

Operating conditions—

Proceed as directed in the operating conditions in the Assay under Lansoprazole.

System suitability—

System performance: When the procedure is run with 10 μL of the standard solution under the above operating conditions, lansoprazole and the internal standard are eluted in this order with the resolution between these peaks being not less than 10.

System repeatability: When the test is repeated 6 times with 10 μL of the standard solution under the above operating conditions, the relative standard deviation of the ratio of the peak area of lansoprazole to that of the internal standard is not more than 1.0%.

Containers and storage Containers—Tight containers.

Lansoprazole Delayed-release Orally Disintegrating Tablets

ランソプラゾール腸溶性口腔内崩壊錠

Lansoprazole Delayed-release Orally Disintegrating Tablets contain not less than 95.0% and not more than 105.0% of the labeled amount of lansoprazole (C₁₆H₁₄F₃N₃O₂S: 369.36).

Method of preparation Prepare as directed under Tablets, with Lansoprazole.

Identification Powder 10 tablets of Lansoprazole Delayed-release Orally Disintegrating Tablets. To a portion of the powder, equivalent to 5 mg of Lansoprazole, add 5 mL of methanol, shake thoroughly, and centrifuge. To 0.1 mL of the supernatant liquid add 10 mL of methanol, and determine the absorption spectrum of this solution as directed under Ultraviolet-visible Spectrophotometry <2.24>: it exhibits a maximum between 282 nm and 286 nm.

Purity Related substances—Keep the sample solution and standard solution at not exceeding 5°C, and use them within 12 hours. Powder not less than 10 tablets of Lansoprazole Delayed-release Orally Disintegrating Tablets. To a portion of the powder, equivalent to 25 mg of Lansoprazole, add 10 mL of a mixture of dilute sodium hydroxide TS and methanol (3:1), sonicate, shake thoroughly, and centrifuge. To 2 mL of the supernatant liquid add diluting solution to make 20 mL, filter through a membrane filter with a pore size not exceeding 0.5 μm, and use the filtrate as the sample solution. Pipet 1 mL of the sample solution, add diluting solution to make exactly 100 mL, and use this solution as the standard solution. Perform the test with exactly 40 μL each of the sample solution and standard solution as directed under Liquid Chromatography <2.01> according to the following conditions, and determine each peak area by the automatic integration method: the area of the peak, having a relative retention time of about 1.1 to lansoprazole, obtained from the sample solution is not larger than 2/5 times the peak area of lansoprazole from the standard solution, and the area of the peak other than lansoprazole and the peak mentioned above from the sample solution is not larger than 1/5 times the peak area of lansoprazole from the standard solution. Furthermore, the total area of the peaks other than lansoprazole from the sample solution is not larger than 1.6 times the peak area of lansoprazole from the standard solution.

Diluting solution: A mixture of acetonitrile, water and

triethylamine (160:40:1), adjusted to pH 11.0 with phosphoric acid. To 100 mL of this solution add 900 mL of water.

Operating conditions—

Detector, column, column temperature, mobile phase A, mobile phase B, and time span of measurement: Proceed as directed in the operating conditions in the Purity (4) under Lansoprazole.

Flowing of mobile phase: Control the gradient by mixing the mobile phases A and B as directed in the following table.

Time after injection of sample (min)	Mobile phase A (vol%)	Mobile phase B (vol%)
0 – 30	90 → 20	10 → 80
30 – 40	20	80

Flow rate: About 0.8 mL per minute (the retention time of lansoprazole is about 24 minutes).

System suitability—

Test for required detectability: Pipet 1 mL of the standard solution, and add diluting solution to make exactly 20 mL. Confirm that the peak area of lansoprazole obtained with 40 μ L of this solution is equivalent to 4 to 6% of that with 40 μ L of the standard solution.

System performance: When the procedure is run with 40 μ L of the standard solution under the above operating conditions, the number of theoretical plates and the symmetry factor of the peak of lansoprazole are not less than 150,000 and not more than 1.5, respectively.

System repeatability: When the test is repeated 6 times with 40 μ L of the standard solution under the above operating conditions, the relative standard deviation of the peak area of lansoprazole is not more than 3.0%.

Uniformity of dosage units <6.02> Perform the test according to the following method: it meets the requirements of the Content uniformity test.

To 1 tablet of Lansoprazole Delayed-release Orally Disintegrating Tablets add 3V/10 mL of dilute sodium hydroxide TS, and sonicate with occasional stirring to disintegrate the tablet completely. Add acetonitrile to make exactly V mL so that each mL contains about 0.15 mg of lansoprazole ($C_{16}H_{14}F_3N_3O_2S$). Centrifuge this solution, and filter the supernatant liquid through a membrane filter with a pore size not exceeding 0.5 μ m. Discard the first 5 mL of the filtrate, pipet 4 mL of the subsequent filtrate, add a mixture of acetonitrile and dilute sodium hydroxide TS (7:3) to make exactly 50 mL, and use this solution as the sample solution. Separately, weigh accurately about 30 mg of Lansoprazole RS (separately determine the water <2.48> in the same manner as Lansoprazole), and dissolve in 60 mL of dilute sodium hydroxide TS, and add acetonitrile to make exactly 200 mL. Pipet 4 mL of this solution, add a mixture of acetonitrile and dilute sodium hydroxide TS (7:3) to make exactly 50 mL, and use this solution as the standard solution. Determine the absorbances, A_T and A_S , at 294 nm of the sample solution and standard solution as directed under Ultraviolet-visible Spectrophotometry <2.24>.

$$\begin{aligned} &\text{Amount (mg) of lansoprazole (C}_{16}\text{H}_{14}\text{F}_3\text{N}_3\text{O}_2\text{S)} \\ &= M_S \times A_T/A_S \times V/200 \end{aligned}$$

M_S : Amount (mg) of Lansoprazole RS taken, calculated on the anhydrous basis

Disintegration Being specified separately when the drug is granted approval based on the Law.

Dissolution Being specified separately when the drug is granted approval based on the Law.

Assay Weigh accurately the mass of not less than 20 tablets of Lansoprazole Delayed-release Orally Disintegrating Tablets, and powder. Weigh accurately a portion of the powder, equivalent to about 0.3 g of lansoprazole ($C_{16}H_{14}F_3N_3O_2S$), add 60 mL of dilute sodium hydroxide TS, sonicate, and shake thoroughly. To this solution add 20 mL of acetonitrile and exactly 20 mL of the internal standard solution, shake thoroughly, and centrifuge. To 1 mL of the supernatant liquid add diluting solution to make 30 mL, and filter through a membrane filter with a pore size not exceeding 0.5 μ m. Discard the first 5 mL of the filtrate, and use the subsequent filtrate as the sample solution. Separately, weigh accurately about 30 mg of Lansoprazole RS (separately determine the water <2.48> in the same manner as Lansoprazole), dissolve in 6 mL of dilute sodium hydroxide TS and 2 mL of acetonitrile, and add exactly 2 mL of the internal standard solution. To 1 mL of this solution add diluting solution to make 30 mL, and use this solution as the standard solution. Perform the test with 10 μ L each of the sample solution and standard solution as directed under Liquid Chromatography <2.01> according to the following conditions, and calculate the ratios, Q_T and Q_S , of the peak area of lansoprazole to that of the internal standard.

$$\begin{aligned} &\text{Amount (mg) of lansoprazole (C}_{16}\text{H}_{14}\text{F}_3\text{N}_3\text{O}_2\text{S)} \\ &= M_S \times Q_T/Q_S \times 10 \end{aligned}$$

M_S : Amount (mg) of Lansoprazole RS taken, calculated on the anhydrous basis

Internal standard solution—A solution of 4'-ethoxyacetophenone in acetonitrile (3 in 400).

Diluting solution: A mixture of water, acetonitrile and triethylamine (60:40:1), adjusted to pH 11.0 with phosphoric acid.

Operating conditions—

Proceed as directed in the operating conditions in the Assay under Lansoprazole.

System suitability—

System performance: When the procedure is run with 10 μ L of the standard solution under the above operating conditions, lansoprazole and the internal standard are eluted in this order with the resolution between these peaks being not less than 10.

System repeatability: When the test is repeated 6 times with 10 μ L of the standard solution under the above operating conditions, the relative standard deviation of the ratio of the peak area of lansoprazole to that of the internal standard is not more than 1.0%.

Containers and storage Containers—Tight containers.

Latamoxef Sodium

ラタモキセフナトリウム

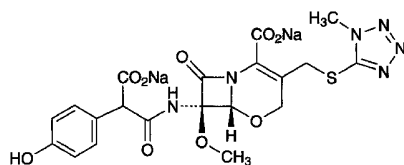

$C_{20}H_{18}N_6Na_2O_9S$: 564.44

Disodium (6*R*,7*R*)-7-[2-carboxylato-2-(4-hydroxyphenyl)acetyl]amino]-7-methoxy-3-(1-methyl-1*H*-tetrazol-5-ylsulfanylmethyl)-8-oxo-5-oxa-1-azabicyclo[4.2.0]oct-2-ene-2-carboxylate
[64953-12-4]

Latamoxef Sodium contains not less than 830 μg (potency) and not more than 940 μg (potency) per mg, calculated on the anhydrous basis. The potency of Latamoxef Sodium is expressed as mass (potency) of latamoxef ($C_{20}H_{20}N_6O_9S$: 520.47).

Description Latamoxef Sodium occurs as white to light yellow-white, powder or masses.

It is very soluble in water, freely soluble in methanol, and slightly soluble in ethanol (95).

Identification (1) Determine the absorption spectrum of a solution of Latamoxef Sodium (3 in 100,000) as directed under Ultraviolet-visible Spectrophotometry <2.24>, and compare the spectrum with the Reference Spectrum: both spectra exhibit similar intensities of absorption at the same wavelengths.

(2) Determine the infrared absorption spectrum of Latamoxef Sodium as directed in the potassium bromide disk method under Infrared Spectrophotometry <2.25>, and compare the spectrum with the Reference Spectrum: both spectra exhibit similar intensities of absorption at the same wave numbers.

(3) Determine the ^1H spectrum of a solution of Latamoxef Sodium in heavy water for nuclear magnetic resonance spectroscopy (1 in 10) as directed under Nuclear Magnetic Resonance Spectroscopy <2.21>, using sodium 3-trimethylsilylpropanesulfonate for nuclear magnetic resonance spectroscopy as an internal reference compound: it exhibits single signals, A and B, at around δ 3.5 ppm and at around δ 4.0 ppm. The ratio of the integrated intensity of these signals, A:B, is about 1:1.

(4) Latamoxef Sodium responds to Qualitative Tests <1.09> (1) for sodium salt.

Optical rotation <2.49> $[\alpha]_D^{20}$: $-32 - -40^\circ$ (0.5 g calculated on the anhydrous basis, phosphate buffer solution (pH 7.0), 50 mL, 100 mm).

pH <2.54> The pH of a solution obtained by dissolving 1.0 g of Latamoxef Sodium in 10 mL of water is between 5.0 and 7.0.

Purity (1) Clarity and color of solution—Dissolve 1.0 g of Latamoxef Sodium in 10 mL of water: the solution is clear and has no more color than the following control solution.

Control solution: To a mixture of 3.0 mL of Cobalt (II) Chloride CS and 36 mL of Iron (III) Chloride CS add 11 mL of diluted dilute hydrochloric acid (1 in 10). To 2.5 mL of this solution add 7.5 mL of diluted dilute hydrochloric acid

(1:10).

(2) Heavy metals <1.07>—Carbonize 1.0 g of Latamoxef Sodium by heating gently, previously powdered if it is masses. After cooling, add 10 mL of a solution of magnesium nitrate hexahydrate in ethanol (1 in 10), and burn the ethanol. After cooling, add 1 mL of sulfuric acid. Proceed according to Method 4, and perform the test. Prepare the control solution with 2.0 mL of Standard Lead Solution (not more than 20 ppm).

(3) Arsenic <1.11>—Prepare the test solution by dissolving 1.0 g of Latamoxef Sodium in 20 mL of water, and perform the test (not more than 2 ppm).

(4) Related substances—Dissolve 25 mg of Latamoxef Sodium in water to make 50 mL, and use this solution as the sample solution. Pipet 2 mL of the sample solution, add water to make exactly 100 mL, and use this solution as the standard solution. Perform the test with exactly 5 μL each of the sample solution and standard solution as directed under Liquid Chromatography <2.01> according to the following conditions, and determine each peak area by the automatic integration method: the peak area of 1-methyl-1*H*-tetrazole-5-thiol, having the relative retention time of about 0.5 to the first eluted peak of the two peaks of latamoxef, obtained from the sample solution is not larger than the peak area of latamoxef from the standard solution, and the peak area of decarboxylatamoxef, having the relative retention time of about 1.7 to the first peak of the two peaks of latamoxef, is not larger than 2 times that of latamoxef from the standard solution. For the peak area of 1-methyl-1*H*-tetrazole-5-thiol, multiply its correction factor, 0.52.

Operating conditions—

Proceed as directed in the operating conditions in the Assay.

System suitability—

System performance: Proceed as directed in the system suitability in the Assay.

System repeatability: When the test is repeated 6 times with 5 μL of the standard solution under the above operating conditions, the relative standard deviation of the peak area of latamoxef is not more than 2.0%.

Water <2.48> Not more than 5.0% (0.5 g, volumetric titration, back titration).

Isomer ratio Dissolve 25 mg of Latamoxef Sodium in water to make 50 mL, and use this solution as the sample solution. Perform the test with 5 μL of the sample solution as directed under Liquid Chromatography <2.01> according to the following conditions, and determine the areas, A_a and A_b , of the two peaks in order of elution, which appear close to each other at the retention time of about 10 minutes: A_a/A_b is between 0.8 and 1.4.

Operating conditions—

Detector: An ultraviolet absorption photometer (wavelength: 254 nm).

Column: A stainless steel column 4 mm in inside diameter and 15 cm in length, packed with octadecylsilanized silica gel for liquid chromatography (10 μm in particle diameter).

Column temperature: A constant temperature of about 25°C.

Mobile phase: Dissolve 7.7 g of ammonium acetate in water to make 1000 mL. To 950 mL of this solution add 50 mL of methanol.

Flow rate: Adjust so that the retention time of the first eluted peak of latamoxef is about 8 minutes.

System suitability—

System performance: When the procedure is run with 5 μL of the sample solution under the above operating conditions,

the resolution between the two peaks of latamoxef is not less than 3.

System repeatability: When the test is repeated 3 times with 5 μ L of the sample solution under the above operating conditions, the relative standard deviation of the area of the first eluted peak of latamoxef is not more than 2.0%.

Assay Weigh accurately an amount of Latamoxef Sodium and Latamoxef Ammonium RS, equivalent to about 25 mg (potency) each, dissolve in exactly 5 mL of the internal standard solution, add water to make 50 mL, and use these solutions as the sample solution and standard solution. Perform the test with 5 μ L each of the sample solution and standard solution as directed under Liquid Chromatography <2.01> according to the following conditions, and calculate the ratios, Q_T and Q_S , of the peak area of latamoxef to that of the internal standard.

$$\begin{aligned} &\text{Amount } [\mu\text{g (potency)}] \text{ of latamoxef (C}_{20}\text{H}_{20}\text{N}_6\text{O}_9\text{S)} \\ &= M_S \times Q_T / Q_S \times 1000 \end{aligned}$$

M_S : Amount [mg (potency)] of Latamoxef Ammonium RS taken

Internal standard solution—A solution of *m*-cresol (3 in 200).

Operating conditions—

Detector: An ultraviolet absorption photometer (wavelength: 254 nm).

Column: A stainless steel column 4 mm in inside diameter and 15 cm in length, packed with octadecylsilanized silica gel for liquid chromatography (10 μ m in particle diameter).

Column temperature: A constant temperature of about 25°C.

Mobile phase: Dissolve 6.94 g of potassium dihydrogen phosphate, 3.22 g of disodium hydrogen phosphate dodecahydrate and 1.60 g of tetra-*n*-butylammonium bromide in water to make exactly 1000 mL. To 750 mL of this solution add 250 mL of methanol.

Flow rate: Adjust so that the retention time of latamoxef is about 7 minutes.

System suitability—

System performance: When the procedure is run with 5 μ L of the standard solution under the above operating conditions, latamoxef and the internal standard are eluted in this order with the resolution between these peaks being not less than 5.

System repeatability: When the test is repeated 6 times with 5 μ L of the standard solution under the above operating conditions, the relative standard deviation of the ratios of the peak area of latamoxef to that of the internal standard is not more than 1.0%.

Containers and storage Containers—Tight containers.

Storage—Not exceeding 5°C.

Lauromacrogol

ラウロマクロゴール

Lauromacrogol is a polyoxyethylene ether prepared by the polymerization of ethylene oxide with laury alcohol.

Description Lauromacrogol is a colorless or light yellow, clear liquid or a white, petrolatum-like or waxy solid. It has a characteristic odor, and a somewhat bitter and slightly irritative taste.

It is very soluble in ethanol (95) and in diethyl ether.

It is freely soluble or dispersed as fine oily drops in water.

Identification (1) Shake thoroughly 0.5 g of Lauromacrogol with 10 mL of water and 5 mL of ammonium thiocyanate-cobalt nitrate TS, then shake with 5 mL of 1-butanol, and allow to stand: the 1-butanol layer becomes blue in color.

(2) Warm Lauromacrogol to melt, if necessary, and determine the infrared absorption spectrum as directed in the liquid film method under Infrared Spectrophotometry <2.25>: it exhibits absorption at the wave numbers of between 3500 cm^{-1} and 3400 cm^{-1} , and about 2920 cm^{-1} , 1350 cm^{-1} , 1250 cm^{-1} , and 1115 cm^{-1} .

Purity (1) Acidity—Transfer 10.0 g of Lauromacrogol into a flask, and add 50 mL of neutralized ethanol. Heat on a water bath nearly to boil, shaking once or twice while heating. Cool, and add 5.3 mL of 0.1 mol/L sodium hydroxide VS and 5 drops of phenolphthalein TS: a red color develops.

(2) Unsaturated compound—Shake 0.5 g of Lauromacrogol with 10 mL of water, and add 5 drops of bromine TS: the color of the solution does not disappear.

Residue on ignition <2.44> Not more than 0.2% (1 g).

Containers and storage Containers—Tight containers.

Lenampicillin Hydrochloride

レナンピシリン塩酸塩

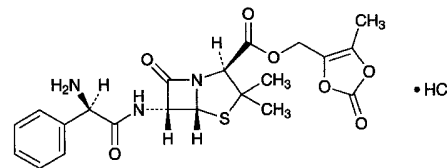

$\text{C}_{21}\text{H}_{23}\text{N}_3\text{O}_7\text{S} \cdot \text{HCl}$: 497.95

5-Methyl-2-oxo[1,3]dioxol-4-ylmethyl (2*S*,5*R*,6*R*)-6-[(2*R*)-2-amino-2-phenylacetyl-amino]-3,3-dimethyl-7-oxo-4-thia-1-azabicyclo[3.2.0]heptane-2-carboxylate monohydrochloride

[80734-02-7]

Lenampicillin Hydrochloride is the hydrochloride of ampicillin methyloxodioxolenylmethyl ester.

It contains not less than 653 μ g (potency) and not more than 709 μ g (potency) per mg, calculated on the anhydrous basis and corrected by the amount of the residual solvents. The potency of Lenampicillin Hydrochloride is expressed as mass (potency) of ampicillin ($\text{C}_{16}\text{H}_{19}\text{N}_3\text{O}_4\text{S}$: 349.40).

Description Lenampicillin Hydrochloride occurs as a white to light yellow-white powder.

It is very soluble in water, in methanol and in ethanol (95), and freely soluble in *N,N*-dimethylformamide.

Identification (1) Determine the infrared absorption spectrum of Lenampicillin Hydrochloride as directed in the potassium chloride disk method under Infrared Spectrophotometry <2.25>, and compare the spectrum with the Reference Spectrum or the spectrum of Lenampicillin Hydrochloride RS: both spectra exhibit similar intensities of absorption at the same wave numbers.

(2) To 1 mL of a solution of Lenampicillin Hydrochloride (1 in 100) add 0.5 mL of dilute nitric acid and 1 drop of

silver nitrate TS: a white precipitate is formed.

Optical rotation <2.49> $[\alpha]_D^{20}$: +174 – +194° (0.2 g calculated on the anhydrous basis and corrected on the amount of residual solvent, ethanol (95), 20 mL, 100 mm).

Purity (1) Heavy metals <1.07>—Proceed with 2.0 g of Lenampicillin Hydrochloride according to Method 2, and perform the test. Prepare the control solution with 2.0 mL of Standard Lead Solution (not more than 10 ppm).

(2) Arsenic <1.11>—Prepare the test solution with 1.0 g of Lenampicillin Hydrochloride according to Method 3, and perform the test (not more than 2 ppm).

(3) Free ampicillin—Weigh accurately about 0.1 g of Lenampicillin Hydrochloride, dissolve in exactly 10 mL of the internal standard solution, and use this solution as the sample solution. Separately, weigh accurately an amount of Ampicillin RS, equivalent to about 25 mg (potency), and dissolve in water to make exactly 100 mL. Pipet 2 mL of this solution, add exactly 10 mL of the internal standard solution, and use this solution as the standard solution. The sample solution should be used to the following test immediately after the solution is prepared. Perform the test with 10 μ L each of the sample solution and standard solution as directed under Liquid Chromatography <2.01> according to the following conditions, and calculate the ratios, Q_T and Q_S , of the peak height of ampicillin to that of the internal standard: the amount of ampicillin is not more than 1.0%.

$$\begin{aligned} \text{Amount (\%)} \text{ of ampicillin (C}_{16}\text{H}_{19}\text{N}_3\text{O}_4\text{S)} \\ = M_S/M_T \times Q_T/Q_S \times 2 \end{aligned}$$

M_S : Amount [mg (potency)] of Ampicillin RS taken

M_T : Amount (mg) of Lenampicillin Hydrochloride taken

Internal standard solution—A solution of anhydrous caffeine in the mobile phase (1 in 50,000).

Operating conditions—

Detector: An ultraviolet absorption photometer (wavelength: 230 nm).

Column: A stainless steel column 4 mm in inside diameter and 30 cm in length, packed with octadecylsilanized silica gel for liquid chromatography (10 μ m in particle diameter).

Column temperature: A constant temperature of about 25°C.

Mobile phase: Dissolve 1.22 g of potassium dihydrogen phosphate in water to make 900 mL, and add 100 mL of acetonitrile.

Flow rate: Adjust so that the retention time of ampicillin is about 7 minutes.

System suitability—

System performance: When the procedure is run with 10 μ L of the standard solution under the above operating conditions, ampicillin and the internal standard are eluted in this order with the resolution between these peaks being not less than 5.

System repeatability: When the test is repeated 6 times with 10 μ L of the standard solution under the above operating conditions, the relative standard deviation of the ratios of the peak height of ampicillin to that of the internal standard is not more than 5%.

(4) Penicilloic acid—Weigh accurately about 0.1 g of Lenampicillin Hydrochloride, dissolve in water to make exactly 100 mL, and use this solution as the sample solution. Pipet 10 mL of the sample solution, add 10 mL of potassium hydrogen phthalate buffer solution (pH 4.6) and exactly 10 mL of 0.005 mol/L iodine VS, allow to stand for exactly 15 minutes while protecting from exposure to light, and titrate <2.50> with 0.01 mol/L sodium thiosulfate VS (indicator: 1

mL of starch TS). Perform a blank determination in the same manner, and make any necessary correction: the amount of penicilloic acid (C₁₆H₂₁N₃O₅S: 367.42) is not more than 3.0%.

$$\begin{aligned} \text{Each mL of 0.01 mol/L sodium thiosulfate VS} \\ = 0.45 \text{ mg of C}_{16}\text{H}_{21}\text{N}_3\text{O}_5\text{S} \end{aligned}$$

(5) Residual solvent <2.46>—Weigh accurately about 0.25 g of Lenampicillin Hydrochloride, dissolve in exactly 1 mL of the internal standard solution, add *N,N*-dimethylformamide to make 5 mL, and use this solution as the sample solution. Separately, weigh accurately about 80 mg of 2-propanol and about 0.12 g of ethyl acetate, and add *N,N*-dimethylformamide to make exactly 100 mL. Pipet 1 mL and 3 mL of this solution, add exactly 1 mL each of the internal standard solution, add *N,N*-dimethylformamide to make 5 mL, and use these solutions as the standard solution (1) and the standard solution (2), respectively. Perform the test with 4 μ L each of the sample solution, standard solution (1) and (2) as directed under Gas Chromatography <2.02> according to the following conditions, and calculate the ratios, Q_{Ta} and Q_{Tb} , of the peak height of 2-propanol and ethyl acetate to that of the internal standard of the sample solution, the ratios, Q_{Sa1} and Q_{Sb1} , of the peak height of 2-propanol and ethyl acetate to that of the internal standard of the standard solution (1) and the ratios, Q_{Sa2} and Q_{Sb2} , of the peak height of 2-propanol and ethyl acetate to that of the internal standard of the standard solution (2). Calculate the amounts of 2-propanol and ethyl acetate by the following equations: not more than 0.7% and not more than 1.7%, respectively.

$$\begin{aligned} \text{Amount (\%)} \text{ of 2-propanol} \\ = M_{Sa}/M_T \times (2Q_{Ta} - 3Q_{Sa1} + Q_{Sa2})/(Q_{Sa2} - Q_{Sa1}) \end{aligned}$$

$$\begin{aligned} \text{Amount (\%)} \text{ of ethyl acetate} \\ = M_{Sb}/M_T \times (2Q_{Tb} - 3Q_{Sb1} + Q_{Sb2})/(Q_{Sb2} - Q_{Sb1}) \end{aligned}$$

M_{Sa} : Amount (g) of 2-propanol taken

M_{Sb} : Amount (g) of ethyl acetate taken

M_T : Amount (g) of the Lenampicillin Hydrochloride taken

Internal standard solution—A solution of cyclohexane in *N,N*-dimethylformamide (1 in 1000).

Operating conditions—

Detector: A hydrogen flame-ionization detector.

Column: A glass column 3 mm in inside diameter and 3 m in length, packed with siliceous earth for gas chromatography (180–250 μ m in particle diameter) coated with tetra-kishydroxypropylethylenediamine for gas chromatography at the ratio of 10 to 15%.

Column temperature: A constant temperature of about 80°C.

Injection port temperature: A constant temperature of about 160°C.

Carrier gas: Nitrogen.

Flow rate: Adjust so that the retention time of the internal standard is about 1 minute.

System suitability—

System performance: When the procedure is run with 4 μ L of the standard solution (2) under the above operating conditions, the internal standard, ethyl acetate and 2-propanol are eluted in this order, and the resolution between the peaks of the internal standard and ethyl acetate is not less than 2.0.

System repeatability: When the test is repeated 3 times with 4 μ L of the standard solution (2) under the above operating conditions, the relative standard deviation of the ratios of the peak height of ethyl acetate to that of the internal standard is not more than 5.0%.

Time after injection of sample (min)	Mobile phase A (vol%)	Mobile phase B (vol%)
0 - 35	100 → 80	0 → 20
35 - 40	80	20

Flow rate: Adjust so that the retention time of the first appeared peak of lenograstim is about 27 minutes.

System suitability—

System performance: When the procedure is run with a volume of the standard solution, equivalent to 20 µg of protein, under the above operating conditions, the resolution between the two peaks of lenograstim is not less than 4.

(2) Desalt 2 mL each of Lenograstim (Genetical Recombination) and Lenograstim RS by a suitable method, and assign them as the desalted sample and the desalted reference standard, respectively. Add the desalted sample and the desalted reference standard in 100 µL each of a mixture of water and 1-propanol (3:2), add 4 mL of urea-EDTA TS, and allow them to stand at 37°C for 18 hours. Then, add 10 µL of 2-mercaptoethanol to them, and allow to stand at 37°C for 4 hours. To these solutions add a solution of 27 mg of iodoacetic acid in 150 µL of sodium hydroxide TS, and react at 37°C for 15 minutes, avoiding exposure to light. Remove the reagents from these reaction solution by a suitable method, and assign obtained these substances as the reduced carboxymethylated sample and the reduced carboxymethylated reference standard. To these substances add 100 µL each of a mixture of water and 1-propanol (3:2), and add 1 mL of 0.05 mol/L ammonium hydrogen carbonate solution. Add 20 µL each of a solution of V8 protease in 0.05 mol/L ammonium hydrogen carbonate solution (1 in 1000), and react at 37°C for 18 hours. To each reaction solution add 50 µL of diluted trifluoroacetic acid (1 in 10) to stop the reaction, and use these solutions as the sample solution and the standard solution, respectively. Perform the test with 100 µL - 150 µL each of the sample solution and standard solution as directed under Liquid Chromatography <2.01> according to the following conditions, and compare the chromatograms from these solutions: both chromatograms show the similar peaks at the corresponding retention time.

Operating conditions—

Detector: An ultraviolet absorption photometer (wavelength: 220 nm).

Column: A stainless steel column 4.6 mm in inside diameter and 25 cm in length, packed with octadecylsilanized silica gel for liquid chromatography (5 µm in particle diameter).

Column temperature: A constant temperature of about 25°C.

Mobile phase A: A mixture of water, acetonitrile for liquid chromatography and trifluoroacetic acid (950:50:1).

Mobile phase B: A mixture of acetonitrile for liquid chromatography, water, and trifluoroacetic acid (800:200:1).

Flowing of mobile phase: Control the gradient by mixing the mobile phases A and B as directed in the following table.

Time after injection of sample (min)	Mobile phase A (vol%)	Mobile phase B (vol%)
0 - 120	100 → 20	0 → 80
120 - 140	20 → 0	80 → 100
140 - 150	0	100

Flow rate: Adjust so that the retention time of the first appeared peak is about 33 minutes.

System suitability—

System performance: When the procedure is run with the standard solution under the above operating conditions, the resolution between the first appeared peak and the second appeared peak is not less than 15.

Monosaccharide composition Put exactly 2 mL of Lenograstim (Genetical Recombination) into a precolumn, packed with 0.36 g of octadecylsilanized silica gel for pretreatment, wash the column with 5 mL of a mixture of water, acetonitrile and trifluoroacetic acid (600:400:1), then elute with a mixture of acetonitrile, water and trifluoroacetic acid (800:200:1), and collect exactly 5 mL of the first eluate. Pipet 1.5 mL of the eluate in a test tube, add exactly 20 µL of the internal standard solution, and lyophilize. Dissolve the lyophilized substance in 250 µL of a mixture of methanol and acetyl chloride (9:1), seal the tube, and heat at 90°C for 2 hours. After cooling, open the tube, and dry the content under reduced pressure. To the residue add 200 µL of methanol, and evaporate to dryness under reduced pressure. Dissolve the residue in 200 µL of a solution of pyridine in methanol (1 in 10) and 50 µL of acetic anhydride, stopper the tube tightly, and allow to stand for 10 minutes. Evaporate the solution to dryness at about 50°C under reduced pressure, add 200 µL of methanol to the residue, and evaporate to dryness at 50°C under reduced pressure. To the residue add 50 µL of a mixture of pyridine, 1,1,1,3,3,3-hexamethyldisilazane and chlorotrimethylsilane (10:2:1), stopper tightly, shake vigorously for 30 seconds, and warm at 50°C for 10 minutes. After cooling, add 300 µL of pentane, stir gently, then add 300 µL of water, and stir gently. Separate the upper layer, evaporate to concentrate to about 10 µL under a stream of nitrogen, and use this as the sample solution. Separately, weigh accurately about 54 mg of D-galactose and about 33 mg of N-acetylgalactosamine, dissolve them separately in water to make exactly 20 mL each, and use these solutions as D-galactose solution and N-acetylgalactosamine solution, respectively. Weigh accurately about 9.3 mg of N-acetylneuraminic acid, add exactly 1 mL of the D-galactose solution and exactly 2 mL of the N-acetylgalactosamine solution to dissolve, and add water to make exactly 20 mL. Pipet 1 mL of this solution, add exactly 1 mL of the internal standard solution, and freeze-dry 40 µL of this solution. Dissolve the freeze-dried substance in 250 µL of a mixture of methanol and acetyl chloride (9:1), then proceed in the same manner as the sample solution, and use the solution obtained as the monosaccharide standard solution. Perform the test with 2 µL each of the sample solution and the monosaccharide standard solution as directed under Gas Chromatography <2.02> according to the following conditions, and calculate the ratios of each peak area of D-galactose, N-acetylgalactosamine and N-acetylneuraminic acid to that of the internal standard, Q_T and Q_S . Calculate the amount (mol/mol of lenograstim) of each monosaccharide by the following formula: the amounts of D-galactose, N-acetylgalactosamine and N-acetylneuraminic acid are between 0.7 and 1.2, between 0.7 and 1.2, and between 1.0 and 2.0, respectively.

Amount (mol/mol of lenograstim) of each monosaccharide = $M / (M_m \times D_s) \times Q_T / Q_S \times 18,667 / C \times 5/3$

M : Amount (mg) of each monosaccharide taken

M_m : Molecular mass of each monosaccharide

D-galactose: 180.16

N-acetylgalactosamine: 221.21

N-acetylneuraminic acid: 309.27

D_s : Dilution rate of each monosaccharide

D-galactose: 20,000

N-acetylgalactosamine and: 10,000

N-acetylneuraminic acid: 1000

C: Protein concentration (mg/mL) of Lenograstim (Genetical Recombination)

18,667: Molecular mass of protein moiety of lenograstim

Internal standard solution—Dissolve 48 mg of myoinositol in water to make 50 mL. To 1 mL of this solution add water to make 20 mL.

Operating conditions—

Detector: A hydrogen flame-ionization detector.

Column: A fused silica column 0.25 mm in inside diameter and 30 m in length, coated the inside surface with 7% cyanopropyl-7% phenyl-methyl silicon polymer for gas chromatography 0.25 μ m in thickness.

Column temperature: Rise the temperature at a rate of 10°C per minute from 110°C to 185°C, then at a rate of 2°C per minute to 210°C, and to 260°C at a rate of 8°C per minute, and maintain 260°C for 15 minutes.

Carrier gas: Helium.

Flow rate: Adjust so that the retention time of the internal standard is about 24 minutes.

System suitability—

System performance: When the procedure is run with 2 μ L of the monosaccharide standard solution under the above operating conditions, D-galactose, the internal standard, *N*-acetylgalactosamine and *N*-acetylneuraminic acid are eluted in this order, and the resolution between the peaks of the internal standard and *N*-acetylgalactosamine is not less than 10.

pH <2.54> 7.7 – 8.3

Purity (1) Related substances—Perform the test with a volume of Lenograstim (Genetical Recombination), equivalent to 30 μ g of protein, as directed under Liquid Chromatography <2.01> according to the following conditions. Determine each peak area by the automatic integration method, and calculate the amount of these peaks by the area percentage method excluding the area of the solvent peak: the total amount of the peaks other than lenograstim is not more than 1.0%.

Operating conditions—

Detector: An ultraviolet absorption photometer (wavelength: 215 nm).

Column: A stainless steel column 7.5 mm in inside diameter and 60 cm in length, packed with porous silica gel for liquid chromatography (10 μ m in particle diameter).

Column temperature: A constant temperature of about 25°C.

Mobile phase: Dissolve 1.4 g of anhydrous disodium hydrogen phosphate and 5.8 g of sodium chloride in water to make 1000 mL (Solution A). Separately, dissolve 1.6 g of sodium dihydrogen phosphate dihydrate and 5.8 g of sodium chloride in water to make 1000 mL (Solution B). Adjust the pH of Solution A to 7.4 with Solution B.

Flow rate: Adjust so that the retention time of lenograstim is about 21 minutes.

Time span of measurement: About 2 times as long as the retention time of lenograstim.

System suitability—

Test for required detectability: When the procedure is run with 60 μ L of diluted Lenograstim RS with the solvent of Lenograstim (Genetical Recombination) containing 0.1 vol% polysorbate 20 (1 in 500) under the above operating conditions, the peak of lenograstim is detectable.

System performance: When the procedure is run using Lenograstim RS under the above operating conditions, the

number of theoretical plates of the peak of lenograstim is not less than 2700.

(2) Host cell proteins—Being specified separately when the drug is granted approval based on the Law.

(3) Host cell DNA—Being specified separately when the drug is granted approval based on the Law.

Assay (1) Protein—Use Lenograstim (Genetical Recombination) and Lenograstim RS as the sample solution and the standard solution, respectively. Perform the test with exactly 30 μ L each of the sample solution and standard solution as directed under Liquid Chromatography <2.01> according to the following conditions, and determine the peak areas, A_T and A_S , of lenograstim in each solution.

$$\begin{aligned} &\text{Amount (mg) of protein in 1 mL of Lenograstim} \\ &\text{(Genetical Recombination)} \\ &= C_S \times A_T/A_S \end{aligned}$$

C_S : Concentration (mg/mL) of protein in Lenograstim RS

Operating conditions—

Detector: An ultraviolet absorption photometer (wavelength: 220 nm).

Column: A stainless steel column 4.6 mm in inside diameter and 25 cm in length, packed with octadecylsilanized silica gel for liquid chromatography (5 μ m in particle diameter).

Column temperature: A constant temperature of about 25°C.

Mobile phase A: A mixture of water, acetonitrile for liquid chromatography and trifluoroacetic acid (600:400:1).

Mobile phase B: A mixture of acetonitrile for liquid chromatography, water and trifluoroacetic acid (800:200:1).

Flowing of mobile phase: Control the gradient by mixing the mobile phases A and B as directed in the following table.

Time after injection of sample (min)	Mobile phase A (vol%)	Mobile phase B (vol%)
0 – 40	80 → 30	20 → 70

Flow rate: Adjust so that the retention time of lenograstim is about 35 minutes.

System suitability—

System performance: When the procedure is run with 30 μ L of the standard solution under the above operating conditions, the number of theoretical plates of the peak of lenograstim is not less than 2900.

System repeatability: When the test is repeated 6 times with 30 μ L of the standard solution under the above operating conditions, the relative standard deviation of the peak area of lenograstim is not more than 4.0%.

(2) Specific activity—Dilute Lenograstim (Genetical Recombination) with FBS-IMDM so that each mL contains an estimate amount of 7.69 units, 10.0 units and 13.0 units, and name them as the sample solution (1), the sample solution (2) and the sample solution (3), respectively. Separately, dilute Lenograstim RS with FBS-IMDM so that each mL contains 7.69 units, 10.0 units and 13.0 units, and name them as the standard solution (1), the standard solution (2) and the standard solution (3), respectively. Put exactly 100 μ L each of the sample solutions and standard solutions in wells of a sterile disposable multiple well plate, add 50 μ L each of NFS-60 cell suspension (prepared by adding FBS-IMDM so the each mL contains about 5×10^5 cells) to each well and mix to make homogenize, and place the plate in a CO₂ incubator at 37°C. After incubation for 22 hours, add 15 μ L of resazurin solution to each well, and determine the

absorbances at 570 nm, A_{T1} and A_{S1} , and at 600 nm, A_{T2} and A_{S2} . From the reaction values at each concentration of the standard solution and sample solution [difference of absorbance ($A_{S1} - A_{S2}$ and $A_{T1} - A_{T2}$)], determine the rate of potency (Pr) of the sample solution to the standard solution by the parallel assay, and calculate the potency (unit) per 1 mg of protein of Lenograstim (Genetical Recombination).

$$Pr = \text{anti ln } (M)$$

$$M = (P_T - P_S)/db$$

$$P_T = T_1 + T_2 + T_3$$

$$P_S = S_1 + S_2 + S_3$$

$$b = H_L(L_S + L_T)/\text{Inh}$$

$$H_L = 12n/(d^3 - d)$$

$$L_S = 1S_1 + 2S_2 + 3S_3 - 1/2(d + 1)P_S$$

$$L_T = 1T_1 + 2T_2 + 3T_3 - 1/2(d + 1)P_T$$

$$d = 3$$

$$I = \ln 1.3$$

$$n = 3$$

$$h = 2$$

T_1 : Mean of reaction values of the sample solution (1)

T_2 : Mean of reaction values of the sample solution (2)

T_3 : Mean of reaction values of the sample solution (3)

S_1 : Mean of reaction values of the standard solution (1)

S_2 : Mean of reaction values of the standard solution (2)

S_3 : Mean of reaction values of the standard solution (3)

Specific activity (unit/mg of protein) of lenograstim

$$= S \times Pr \times D_T/D_S/C$$

S: Potency (unit/mL) of Lenograstim RS

D_T : Dilution rate of the sample solution (3)

D_S : Dilution rate of the standard solution (3)

C: Concentration (mg/mL) of protein of sample

Containers and storage Containers—Tight containers.

Storage—At a temperature not exceeding -20°C .

L-Leucine

L-ロイシン

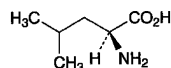

$\text{C}_6\text{H}_{13}\text{NO}_2$: 131.17

(2S)-2-Amino-4-methylpentanoic acid
[61-90-5]

L-Leucine, when dried, contains not less than 98.5% of L-leucine ($\text{C}_6\text{H}_{13}\text{NO}_2$).

Description L-Leucine occurs as white, crystals or crystalline powder. It is odorless or has a faint characteristic odor, and has a slightly bitter taste.

It is freely soluble in formic acid, sparingly soluble in water, and practically insoluble in ethanol (95).

It dissolves in dilute hydrochloric acid.

Identification Determine the infrared absorption spectrum of L-Leucine, previously dried, as directed in the potassium bromide disk method under Infrared Spectrophotometry <2.25>, and compare the spectrum with the Reference Spectrum: both spectra exhibit similar intensities of absorption at the same wave numbers.

Optical rotation <2.49> $[\alpha]_D^{20}$: $+14.5 - +16.0^\circ$ (after drying, 1 g, 6 mol/L hydrochloric acid TS, 25 mL, 100 mm).

pH <2.54> Dissolve 1.0 g of L-Leucine in 100 mL of water:

the pH of this solution is between 5.5 and 6.5.

Purity (1) Clarity and color of solution—Dissolve 0.5 g of L-Leucine in 10 mL of 1 mol/L hydrochloric acid TS: the solution is clear and colorless.

(2) Chloride <1.03>—Dissolve 0.5 g of L-Leucine in 40 mL of water and 6 mL of dilute nitric acid, and add water to make 50 mL. Perform the test using this solution as the test solution. Prepare the control solution with 0.30 mL of 0.01 mol/L hydrochloric acid VS (not more than 0.021%).

(3) Sulfate <1.14>—Dissolve 0.6 g of L-Leucine in 40 mL of water and 1 mL of dilute hydrochloric acid, and add water to make 50 mL. Perform the test using this solution as the test solution. Prepare the control solution with 0.35 mL of 0.005 mol/L sulfuric acid VS (not more than 0.028%).

(4) Ammonium <1.02>—Perform the test with 0.25 g of L-Leucine. Prepare the control solution with 5.0 mL of Standard Ammonium Solution (not more than 0.02%).

(5) Heavy metals <1.07>—Proceed with 1.0 g of L-Leucine according to Method 4, and perform the test. Prepare the control solution with 2.0 mL of Standard Lead Solution (not more than 20 ppm).

(6) Arsenic <1.11>—Prepare the test solution with 1.0 g of L-Leucine according to Method 2, and perform the test (not more than 2 ppm).

(7) Related substances—Dissolve 0.10 g of L-Leucine in water by warming, after cooling, add water to make 25 mL, and use this solution as the sample solution. Pipet 1 mL of the sample solution, and add water to make exactly 50 mL. Pipet 5 mL of this solution, add water to make exactly 20 mL, and use this solution as the standard solution. Perform the test with these solutions as directed under Thin-layer Chromatography <2.03>. Spot 5 μL each of the sample solution and standard solution on a plate of silica gel for thin-layer chromatography. Develop the plate with a mixture of 1-butanol, water and acetic acid (100) (3:1:1) to a distance of about 10 cm, and dry the plate at 80°C for 30 minutes. Spray evenly a solution of ninhydrin in acetone (1 in 50) on the plate, and heat the plate at 80°C for 5 minutes: the spots other than the principal spot obtained from the sample solution are not more intense than the spot from the standard solution.

Loss on drying <2.41> Not more than 0.30% (1 g, 105°C , 3 hours).

Residue on ignition <2.44> Not more than 0.1% (1 g).

Assay Weigh accurately about 0.13 g of L-Leucine, previously dried, and dissolve in 3 mL of formic acid, add 50 mL of acetic acid (100), and titrate <2.50> with 0.1 mol/L perchloric acid VS (potentiometric titration). Perform a blank determination in the same manner, and make any necessary correction.

$$\begin{aligned} \text{Each mL of 0.1 mol/L perchloric acid VS} \\ = 13.12 \text{ mg of } \text{C}_6\text{H}_{13}\text{NO}_2 \end{aligned}$$

Containers and storage Containers—Well-closed containers.

Leuprorelin Acetate

リユープロレリン酢酸塩

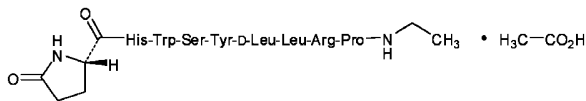

$C_{59}H_{84}N_{16}O_{12} \cdot C_2H_4O_2$: 1269.45

5-Oxo-L-prolyl-L-histidyl-L-tryptophyl-L-seryl-L-tyrosyl-D-leucyl-L-leucyl-L-arginyl-N-ethyl-L-prolinamide monoacetate
[74381-53-6]

Leuprorelin Acetate contains not less than 96.0% and not more than 102.0% of leuprorelin ($C_{59}H_{84}N_{16}O_{12}$: 1209.40), calculated on the anhydrous and residual acetic acid-free basis.

Description Leuprorelin Acetate occurs as a white to yellowish white powder.

It is very soluble in water and in acetic acid (100), freely soluble in methanol, and sparingly soluble in ethanol (99.5).

It is hygroscopic.

Identification Determine the infrared absorption spectrum of Leuprorelin Acetate as directed in the potassium bromide disk method under Infrared Spectrophotometry <2.25>, and compare the spectrum with the Reference Spectrum or the spectrum of Leuprorelin Acetate RS: both spectra exhibit similar intensities of absorption at the same wave numbers.

Optical rotation <2.49> $[\alpha]_D^{20}$: $-38 - -41^\circ$ (0.25 g calculated on the anhydrous and residual acetic acid-free basis, diluted acetic acid (100) (1 in 100), 25 mL, 100 mm).

pH <2.54> The pH of a solution of 0.10 g of Leuprorelin Acetate in 10 mL of water is 5.5 to 7.5.

Constituent amino acids When hydrolyzed by Method 1 described in "1. Hydrolysis of Protein and Peptide" and performed the test by Method 1 described in "2. Methodologies of Amino Acid Analysis" under Amino Acid Analysis of Proteins <2.04>, histidine, glutamic acid, proline, tyrosine and arginine is 1 and leucine is 2, respectively.

Procedure

(i) **Hydrolysis** Weigh accurately about 50 mg of Leuprorelin Acetate, and dissolve in 1 mL of water. Put 0.1 mL of this solution in a test tube for hydrolysis, freeze-dry the content, and add 2 mL of a solution of phenol in 6 mol/L hydrochloric acid (1 in 200). Freeze the solution, seal the tube in vacuum, and heat the tube at 110°C for 24 hours. After cooling, open the tube, take out 0.1 mL of the hydrolyzate, add 1 mL of water, and freeze-dry. Dissolve the residue in 7.8 mL of diluting solution, and use this solution as the sample solution. Separately, weigh exactly 0.45 mg of L-alanine, 0.66 mg of L-aspartic acid, 1.05 mg of L-arginine hydrochloride, 0.74 mg of L-glutamic acid, 0.38 mg of glycine, 1.05 mg of L-histidine hydrochloride monohydrate, 0.66 mg of L-isoleucine, 0.66 mg of L-leucine, 0.58 mg of L-proline, 0.53 mg of L-serine, 0.60 mg of L-threonine and 0.91 mg of L-tyrosine, dissolve in diluting solution to make exactly 100 mL, and use this solution as the standard solution (1). Separately, dissolve 1 mg of L-tryptophan and 0.4 mg of ethylamine hydrochloride in diluting solution to make 100 mL, and use this solution as the standard solution (2).

(ii) **Amino acid analysis** Perform the test with exactly 100 μ L each of the sample solution and the standard solutions (1) and (2) as directed under Liquid Chromatography

<2.01> according to the following conditions: the peaks of histidine, glutamic acid, leucine, proline, tyrosine, arginine, serine and tryptophan appear on the chromatogram obtained from the sample solution. Apart from this, calculate the molar content of each constituent amino acid in 1 mL of the sample solution from the peak area of each amino acid obtained from the sample solution and standard solution (1), and further calculate the number of the constituent amino acids assuming that the sum of each molar content of histidine, glutamic acid, leucine, proline, tyrosine and arginine in 1 mole of leuprorelin acetate is 7.

Diluting solution: Dissolve 6.29 g of lithium hydroxide monohydrate and 10.51 g of citric acid monohydrate in water to make 1000 mL, and adjust to pH 2.2 with hydrochloric acid.

Operating conditions—

Detector: A visible spectrophotometer (wavelength: 440 nm and 570 nm).

Column: A stainless steel column 4.6 mm in inside diameter and 6 cm in length, packed with strongly acidic ion-exchange resin (Na type) for liquid chromatography (3 μ m in particle diameter).

Column temperature: Maintain a constant temperature of about 58°C for 18 minutes after injection, then maintain a constant temperature of about 70°C for a further 20 minutes.

Reaction vessel temperature: A constant temperature of about 135°C.

Mobile phase: Prepare the mobile phases A, B, C, D and E according to the following table, then add 0.1 mL of caprylic acid to each mobile phase.

	Mobile phase A	Mobile phase B	Mobile phase C	Mobile phase D	Mobile phase E
Citric acid monohydrate	19.80 g	22.00 g	12.80 g	6.10 g	—
Trisodium citrate dihydrate	6.19 g	7.74 g	13.31 g	26.67 g	—
Sodium chloride	5.66 g	7.07 g	3.74 g	54.35 g	—
Sodium hydroxide	—	—	—	—	8.00 g
Ethanol (99.5)	130 mL	20.0 mL	4.0 mL	—	100 mL
Thiodiglycol	5.0 mL	5.0 mL	5.0 mL	—	—
Benzyl alcohol	—	—	—	5.0 mL	—
Lauro-macrogol solution (1 in 4)	4.0 mL	4.0 mL	4.0 mL	4.0 mL	4.0 mL
Water	a sufficient amount	a sufficient amount	a sufficient amount	a sufficient amount	a sufficient amount
Total amount	1000 mL	1000 mL	1000 mL	1000 mL	1000 mL

Flowing of mobile phase: Control the gradient by mixing the mobile phases A, B, C, D and E as directed in the following table.

Time after injection of sample (min)	Mobile phase A (vol%)	Mobile phase B (vol%)	Mobile phase C (vol%)	Mobile phase D (vol%)	Mobile phase E (vol%)
0 - 1.6	100	0	0	0	0
1.6 - 4.5	0	100	0	0	0
4.5 - 13.5	0	0	100	0	0
13.5 - 27.0	0	0	0	100	0
27.0 - 33.0	0	0	0	0	100

Reaction reagent: Dissolve an appropriate amount of lithium acetate dihydrate, acetic acid (100) and 1-methoxy-2-propanol in water to make 1000 mL, and use this solution as solution A. Separately, dissolve an appropriate amount of ninhydrin and sodium borohydride in 1-methoxy-2-propanol to make 1000 mL, and use this solution as solution B. Mix equal parts of solutions A and B before use.

Flow rate of mobile phase: About 0.40 mL per minute.

Flow rate of reaction reagent: About 0.35 mL per minute.

System suitability—

System performance: When the procedure is run with 100 μ L of the standard solution (1) under the above operating conditions, the resolutions between the peaks of threonine and serine, glycine and alanine, and isoleucine and leucine are not less than 1.2, respectively.

System repeatability: When the test is repeated 5 times with 100 μ L of the standard solution (1) under the above operating conditions, the relative standard deviation of the peak area of arginine, aspartic acid, proline and serine is not more than 4.0%.

Purity Related substances—Dissolve 0.10 g of Leuprorelin Acetate in the mobile phase to make 100 mL, and use this solution as the sample solution. Pipet 1 mL of the sample solution, add the mobile phase to make exactly 100 mL, and use this solution as the standard solution. Perform the test with exactly 20 μ L each of the sample solution and standard solution as directed under Liquid Chromatography <2.01> according to the following conditions, and determine each peak area by the automatic integration method: the area of the peaks, having the relative retention time of about 0.65, about 0.77, about 0.78 and about 0.90 to leuprorelin, obtained from the sample solution is not larger than 1/2 times the peak area of leuprorelin from the standard solution, and the total area of the peaks other than leuprorelin from the sample solution is not larger than 2 times the peak area of leuprorelin from the standard solution.

Operating conditions—

Detector, column, column temperature, mobile phase, and flow rate: Proceed as directed in the operating conditions in the Assay.

Time span of measurement: About 2 times as long as the retention time of leuprorelin, beginning after the solvent peak.

System suitability—

System performance and system repeatability: Proceed as directed in the system suitability in the Assay.

Test for required detectability: To exactly 1 mL of the standard solution add the mobile phase to make exactly 20 mL. Confirm that the peak area of leuprorelin obtained with 20 μ L of this solution is equivalent to 3.5 to 6.5% of that with 20 μ L of the standard solution.

Water <2.48> Not more than 5.0% (0.1 g, coulometric titration).

Residue on ignition <2.44> Not more than 0.2% (0.5 g).

Acetic acid Weigh accurately about 0.1 g of Leuprorelin Acetate, dissolve in the mobile phase to make exactly 10 mL, and use this solution as the sample solution. Separately, weigh accurately about 0.1 g of acetic acid (100), add the mobile phase to make exactly 100 mL, and use this solution as the standard solution. Perform the test with exactly 10 μ L each of the sample solution and standard solution as directed under Liquid Chromatography <2.01> according to the following conditions. Determine the peak areas, A_T and A_S , of acetic acid in each solution, and calculate the amount of acetic acid by the following equation: 4.7 - 8.0%.

$$\text{Amount (\% of acetic acid)} = M_S/M_T \times A_T/A_S \times 10$$

M_S : Amount (g) of acetic acid (100) taken

M_T : Amount (g) of Leuprorelin Acetate taken

Operating conditions—

Detector: An ultraviolet absorption photometer (wavelength: 210 nm).

Column: A stainless steel column 4.6 mm in inside diameter and 25 cm in length, packed with octadecylsilanized silica gel for liquid chromatography (5 μ m in particle diameter).

Column temperature: A constant temperature of about 25°C.

Mobile phase: To 0.7 mL of phosphoric acid add water to make 1000 mL, and adjust to pH 3.0 with a solution of sodium hydroxide (21 in 50). To 950 mL of this solution add 50 mL of methanol.

Flow rate: Adjust so that the retention time of acetic acid is 3 to 4 minutes.

System suitability—

System performance: When the procedure is run with 10 μ L of the standard solution under the above operating conditions, the symmetry factor of the peak of acetic acid is not more than 1.5.

System repeatability: When the test is repeated 6 times with 10 μ L of the standard solution under the above operating conditions, the relative standard deviation of the peak area of acetic acid is not more than 2.0%.

Assay Weigh accurately about 0.1 g each of Leuprorelin Acetate and Leuprorelin Acetate RS (separately determine the water <2.48> and acetic acid in the same manner as Leuprorelin Acetate), dissolve separately in the mobile phase to make exactly 100 mL. To exactly 5 mL each of these solutions add the mobile phase to make them exactly 100 mL, and use so obtained solutions as the sample solution and the standard solution, respectively. Perform the test with exactly 20 μ L each of the sample solution and standard solution as directed under Liquid Chromatography <2.01> according to the following conditions, and determine the peak areas, A_T and A_S , of leuprorelin in each solution.

$$\begin{aligned} \text{Amount (mg) of leuprorelin (C}_{59}\text{H}_{84}\text{N}_{16}\text{O}_{12}) \\ = M_S \times A_T/A_S \end{aligned}$$

M_S : Amount (mg) of Leuprorelin Acetate RS taken, calculated on the anhydrous and de-acetic acid basis

Operating conditions—

Detector: An ultraviolet absorption photometer (wavelength: 220 nm).

Column: A stainless steel column 4.6 mm in inside diameter and 10 cm in length, packed with octadecylsilanized silica gel for liquid chromatography (3 μ m in particle diameter).

Column temperature: A constant temperature of about 25°C.

Mobile phase: Dissolve 15.2 g of triethylamine in 800 mL of water, adjust to pH 3.0 with phosphoric acid, and add

water to make 1000 mL. To 850 mL of this solution add 150 mL of a mixture of acetonitrile and 1-propanol (3:2).

Flow rate: Adjust so that the retention time of leuprorelin is 41 to 49 minutes (1.0 – 1.5 mL per minute).

System suitability—

System performance: Dissolve about 0.1 g of Leuprorelin Acetate RS in 100 mL of the mobile phase. To 5 mL of this solution add water to make 50 mL. To 5 mL of this solution add 0.1 mL of sodium hydroxide TS, stopper the vessel, shake vigorously, then heat at 100°C for 60 minutes. After cooling, add 50 μ L of 1 mol/L phosphoric acid solution, and shake vigorously. When the procedure is run with 20 μ L of this solution under the above operating conditions, a peak having the relative retention time of about 0.90 to leuprorelin and leuprorelin are eluted in this order with the resolution between these peaks being not less than 1.5.

System repeatability: When the test is repeated 5 times with 20 μ L of the standard solution under the above operating conditions, the relative standard deviation of the peak area of leuprorelin is not more than 1.5%.

Containers and storage Containers—Hermetic containers.

Levallorphan Tartrate

レバロルファン酒石酸塩

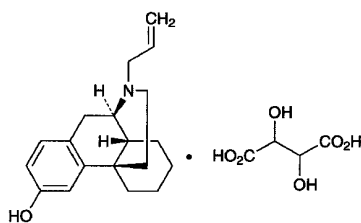

$C_{19}H_{25}NO \cdot C_4H_6O_6$: 433.49

17-Allylmorphinan-3-ol monotartrate

[71-82-9]

Levallorphan Tartrate, when dried, contains not less than 98.5% of levallorphan tartrate ($C_{19}H_{25}NO \cdot C_4H_6O_6$).

Description Levallorphan Tartrate occurs as a white to pale yellow crystalline powder. It is odorless.

It is soluble in water and in acetic acid (100), sparingly soluble in ethanol (95), and practically insoluble in diethyl ether.

Identification (1) Determine the absorption spectrum of a solution of Levallorphan Tartrate in 0.01 mol/L hydrochloric acid TS (1 in 10,000) as directed under Ultraviolet-visible Spectrophotometry <2.24>, and compare the spectrum with the Reference Spectrum: both spectra exhibit similar intensities of absorption at the same wavelengths.

(2) Determine the infrared absorption spectrum of Levallorphan Tartrate, previously dried, as directed in the potassium bromide disk method under Infrared Spectrophotometry <2.25>, and compare the spectrum with the Reference Spectrum: both spectra exhibit similar intensities of absorption at the same wave numbers.

(3) A solution of Levallorphan Tartrate (1 in 30) responds to Qualitative Tests <1.09> (1) and (2) for tartrate.

Optical rotation <2.49> $[\alpha]_D^{20}$: $-37.0 - -39.2^\circ$ (after drying, 0.2 g, water, 10 mL, 100 mm).

pH <2.54> Dissolve 0.2 g of Levallorphan Tartrate in 20

mL of water: the pH of this solution is between 3.3 and 3.8.

Melting point <2.60> 174 – 178°C

Purity (1) Clarity and color of solution—Dissolve 0.2 g of Levallorphan Tartrate in 10 mL of water: the solution is clear and colorless.

(2) Heavy metals <1.07>—Proceed with 1.0 g of Levallorphan Tartrate according to Method 4, and perform the test. Prepare the control solution with 2.0 mL of Standard Lead Solution (not more than 20 ppm).

(3) Related substances—Dissolve 0.20 g of Levallorphan Tartrate in 10 mL of water, and use this solution as the sample solution. Pipet 1 mL of the sample solution, add water to make exactly 100 mL, and use this solution as the standard solution. Perform the test with these solutions as directed under Thin-layer Chromatography <2.03>. Spot 20 μ L each of the sample solution and standard solution on a plate of silica gel for thin-layer chromatography. Develop the plate with a mixture of methanol and ammonia TS (200:3) to a distance of about 10 cm, and air-dry the plate. Spray evenly Dragendorff's TS for spraying on the plate: the spots other than the principal spot obtained from the sample solution are not more intense than the spot from the standard solution.

Loss on drying <2.41> Not more than 0.5% (1 g, in vacuum, phosphorus (V) oxide, 80°C, 4 hours).

Residue on ignition <2.44> Not more than 0.10% (1 g).

Assay Weigh accurately about 0.5 g of Levallorphan Tartrate, previously dried, dissolve in 30 mL of acetic acid (100), and titrate <2.50> with 0.1 mol/L perchloric acid VS (indicator: 2 drops of crystal violet TS). Perform a blank determination in the same manner, and make any necessary correction.

Each mL of 0.1 mol/L perchloric acid VS
= 43.35 mg of $C_{19}H_{25}NO \cdot C_4H_6O_6$

Containers and storage Containers—Well-closed containers.

Levallorphan Tartrate Injection

レバロルファン酒石酸塩注射液

Levallorphan Tartrate Injection is an aqueous injection.

It contains not less than 93.0% and not more than 107.0% of the labeled amount of levallorphan tartrate ($C_{19}H_{25}NO \cdot C_4H_6O_6$: 433.49).

Method of preparation Prepare as directed under Injection, with Levallorphan Tartrate.

Description Levallorphan Tartrate Injection is a clear, colorless liquid.

pH: 3.0 – 4.5

Identification Take an exact volume of Levallorphan Tartrate Injection, equivalent to 3 mg of Levallorphan Tartrate, add 5 mL of water and 2 drops of dilute hydrochloric acid, and wash with five 15-mL portions of diethyl ether by a vigorous shaking. Take the water layer, evaporate the diethyl ether remained by warming on a water bath, and after cooling, add 0.01 mol/L hydrochloric acid TS to make 50 mL. Determine the absorption spectrum of this solution as directed under Ultraviolet-visible Spectrophotometry <2.24>: it

exhibits a maximum between 277 nm and 281 nm.

Bacterial endotoxins <4.01> Less than 150 EU/mg.

Extractable volume <6.05> It meets the requirement.

Foreign insoluble matter <6.06> Perform the test according to Method 1: it meets the requirement.

Insoluble particulate matter <6.07> It meets the requirement.

Sterility <4.06> Perform the test according to the Membrane filtration method: it meets the requirement.

Assay Take exactly a volume of Levallorphan Tartrate Injection, equivalent to about 2 mg of levallorphan tartrate ($C_{19}H_{25}NO \cdot C_4H_6O_6$), add exactly 10 mL of the internal standard solution, and use this solution as the sample solution. Separately, weigh accurately about 0.1 g of levallorphan tartrate for assay, previously dried at 80°C for 4 hours on phosphorus (V) oxide under reduced pressure, and dissolve in water to make exactly 100 mL. Pipet 2 mL of this solution, add exactly 10 mL of the internal standard solution, and use this solution as the standard solution. Perform the test with 10 μ L each of the sample solution and standard solution as directed under Liquid Chromatography <2.01> according to the following conditions, and calculate the ratios, Q_T and Q_S , of the peak area of levallorphan to that of the internal standard:

$$\text{Amount (mg) of levallorphan tartrate (C}_{19}\text{H}_{25}\text{NO} \cdot \text{C}_4\text{H}_6\text{O}_6) = M_S \times Q_T / Q_S \times 1/50$$

M_S : Amount (mg) of levallorphan tartrate for assay taken

Internal standard solution—Dissolve 0.04 g of isobutyl parahydroxybenzoate in 10 mL of ethanol (95), add water to make 100 mL, and to 10 mL of this solution add water to make 100 mL.

Operating conditions—

Detector: An ultraviolet absorption photometer (wavelength: 280 nm).

Column: A stainless steel column 4.6 mm in inside diameter and 15 cm in length, packed with octadecylsilanized silica gel for liquid chromatography (5 μ m in particle diameter).

Column temperature: A constant temperature of about 40°C.

Mobile phase: Dissolve 1.0 g of sodium lauryl sulfate in 500 mL of diluted phosphoric acid (1 in 1000), and adjust the pH to 3.0 with sodium hydroxide TS. To 300 mL of this solution add 200 mL of acetonitrile.

Flow rate: Adjust so that the retention time of levallorphan is about 12 minutes.

System suitability—

System performance: When the procedure is run with 10 μ L of the standard solution under the above operating conditions, the internal standard and levallorphan are eluted in this order with the resolution between these peaks being not less than 5.

System repeatability: When the test is repeated 6 times with 10 μ L of the standard solution under the above operating conditions, the relative standard deviation of the ratios of the peak area of levallorphan to that of the internal standard is not more than 1.0%.

Containers and storage Containers—Hermetic containers.

Levodopa

レボドパ

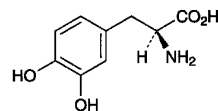

$C_9H_{11}NO_4$: 197.19
3-Hydroxy-L-tyrosine
[59-92-7]

Levodopa, when dried, contains not less than 98.5% of levodopa ($C_9H_{11}NO_4$).

Description Levodopa occurs as white or slightly grayish white, crystals or crystalline powder. It is odorless.

It is freely soluble in formic acid, slightly soluble in water, and practically insoluble in ethanol (95).

It dissolves in dilute hydrochloric acid.

The pH of a saturated solution of Levodopa is between 5.0 and 6.5.

Melting point: about 275°C (with decomposition).

Identification (1) To 5 mL of a solution of Levodopa (1 in 1000) add 1 mL of ninhydrin TS, and heat for 3 minutes in a water bath: a purple color develops.

(2) To 2 mL of a solution of Levodopa (1 in 5000) add 10 mL of 4-aminoantipyrine TS, and shake: a red color develops.

(3) Dissolve 3 mg of Levodopa in 0.001 mol/L hydrochloric acid TS to make 100 mL. Determine the absorption spectrum of the solution as directed under Ultraviolet-visible Spectrophotometry <2.24>, and compare the spectrum with the Reference Spectrum: both spectra exhibit similar intensities of absorption at the same wavelengths.

Absorbance <2.24> $E_{1\text{cm}}^{1\%}$ (280 nm): 136 – 146 (after drying, 30 mg, 0.001 mol/L hydrochloric acid TS, 1000 mL).

Optical rotation <2.49> $[\alpha]_D^{20}$: –11.5 – –13.0° (after drying, 2.5 g, 1 mol/L hydrochloric acid TS, 50 mL, 100 mm).

Purity (1) Clarity and color of solution—Dissolve 1.0 g of Levodopa in 20 mL of 1 mol/L hydrochloric acid TS: the solution is clear and colorless.

(2) Chloride <1.03>—Dissolve 0.5 g of Levodopa in 6 mL of dilute nitric acid, and add water to make 50 mL. Perform the test using this solution as the test solution. Prepare the control solution with 0.30 mL of 0.01 mol/L hydrochloric acid VS (not more than 0.021%).

(3) Sulfate <1.14>—Dissolve 0.40 g of Levodopa in 1 mL of dilute hydrochloric acid and 30 mL of water, and add water to make 50 mL. Perform the test using this solution as the test solution. Prepare the control solution with 0.25 mL of 0.005 mol/L sulfuric acid VS (not more than 0.030%).

(4) Heavy metals <1.07>—Proceed with 1.0 g of Levodopa according to Method 2, and perform the test. Prepare the control solution with 2.0 mL of Standard Lead Solution (not more than 20 ppm).

(5) Arsenic <1.11>—Dissolve 1.0 g of Levodopa in 5 mL of dilute hydrochloric acid, and perform the test with this solution as the test solution (not more than 2 ppm).

(6) Related substances—Dissolve 0.10 g of Levodopa in 10 mL of sodium disulfite TS, and use this solution as the sample solution. Pipet 1 mL of the sample solution, add sodium disulfite TS to make exactly 25 mL. Pipet 1 mL of this solution, add sodium disulfite TS to make exactly 20 mL,

and use this solution as the standard solution. Perform the test with these solutions as directed under Thin-layer Chromatography <2.03>. Spot 5 μL each of the sample solution and standard solution on a plate of cellulose for thin-layer chromatography. Develop the plate with a mixture of 1-butanol, water, acetic acid (100) and methanol (10:5:5:1) to a distance of about 10 cm, and air-dry the plate. Spray evenly a solution of ninhydrin in acetone (1 in 50) on the plate and heat the plate at 90°C for 10 minutes: the spots other than the principal spot obtained from the sample solution are not more intense than the spot from the standard solution.

Loss on drying <2.41> Not more than 0.30% (1 g, 105°C, 3 hours).

Residue on ignition <2.44> Not more than 0.1% (1 g).

Assay Weigh accurately about 0.3 g of Levofloxacin, previously dried, dissolve in 3 mL of formic acid, add 80 mL of acetic acid (100), and titrate <2.50> with 0.1 mol/L perchloric acid VS until the color of the solution changes from purple through blue-green to green (indicator: 3 drops of crystal violet TS). Perform a blank determination in the same manner, and make any necessary correction.

Each mL of 0.1 mol/L perchloric acid VS
= 19.72 mg of $\text{C}_{18}\text{H}_{20}\text{FN}_3\text{O}_4$

Containers and storage Containers—Tight containers.
Storage—Light-resistant.

Levofloxacin Hydrate

レボフロキサシン水和物

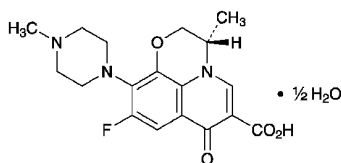

$\text{C}_{18}\text{H}_{20}\text{FN}_3\text{O}_4 \cdot \frac{1}{2}\text{H}_2\text{O}$: 370.38
(3S)-9-Fluoro-3-methyl-10-(4-methylpiperazin-1-yl)-7-oxo-2,3-dihydro-7H-pyrido[1,2,3-de][1,4]benzoxazine-6-carboxylic acid hemihydrate
[138199-71-0]

Levofloxacin Hydrate contains not less than 99.0% and not more than 101.0% of levofloxacin ($\text{C}_{18}\text{H}_{20}\text{FN}_3\text{O}_4$: 361.37), calculated on the anhydrous basis.

Description Levofloxacin Hydrate occurs as light yellowish white to yellow-white, crystals or crystalline powder.

It is freely soluble in acetic acid (100), sparingly soluble in water and in methanol, and slightly soluble in ethanol (99.5).

It dissolves in 0.1 mol/L hydrochloric acid TS.

It gradually turns dark light yellow-white on exposure to light.

Melting point: about 226°C (with decomposition).

Identification (1) Determine the absorption spectrum of a solution of Levofloxacin Hydrate in 0.1 mol/L hydrochloric acid TS (1 in 150,000) as directed under Ultraviolet-visible Spectrophotometry <2.24>, and compare the spectrum with the Reference Spectrum: both spectra exhibit similar intensities of absorption at the same wavelengths.

(2) Determine the infrared absorption spectrum of

Levofloxacin Hydrate as directed in the potassium bromide disk method under Infrared Spectrophotometry <2.25>, and compare the spectrum with the Reference Spectrum: both spectra exhibit similar intensities of absorption at the same wave numbers.

Optical rotation <2.49> $[\alpha]_{\text{D}}^{20}$: $-92 - -99^\circ$ (0.1 g calculated on the anhydrous basis, methanol, 10 mL, 100 mm).

Purity (1) Heavy metals <1.07>—Proceed with 2.0 g of Levofloxacin Hydrate according to Method 4, and perform the test. Prepare the control solution with 2.0 mL of Standard Lead Solution (not more than 10 ppm).

(2) Related substances—Conduct this procedure using light-resistant vessels. Dissolve 50 mg of Levofloxacin Hydrate in 10 mL of a mixture of water and methanol (1:1), and use this solution as the sample solution. Pipet 1 mL of the sample solution, and add a mixture of water and methanol (1:1) to make exactly 10 mL. Pipet 1 mL of this solution, add a mixture of water and methanol (1:1) to make exactly 10 mL, and use this solution as the standard solution. Perform the test with exactly 10 μL each of the sample solution and standard solution as directed under Liquid Chromatography <2.01> according to the following conditions. Determine each peak area of both solutions by the automatic integration method: the area of the peak of the enantiomer having the relative retention time of about 1.2 to levofloxacin obtained from the sample solution is not larger than 2/5 times the peak area of levofloxacin from the standard solution, and the area of each peak other than the peaks of levofloxacin and the enantiomer from the sample solution is not larger than 1/5 times the peak area of levofloxacin from the standard solution. Furthermore, the total area of the peaks other than levofloxacin and the peak of the enantiomer from the sample solution is not larger than 3/10 times the peak area of levofloxacin from the standard solution.

Operating conditions—

Detector: An ultraviolet absorption photometer (wavelength: 340 nm).

Column: A stainless steel column 4.6 mm in inside diameter and 15 cm in length, packed with octadecylsilanized silica gel for liquid chromatography (5 μm in particle diameter).

Column temperature: A constant temperature of about 45°C.

Mobile phase: Dissolve 1.76 g of L-valine, 7.71 g of ammonium acetate and 1.25 g of Copper (II) sulfate pentahydrate in water to make 1000 mL. To this solution add 250 mL of methanol.

Flow rate: Adjust so that the retention time of levofloxacin is about 22 minutes.

Time span of measurement: About 2 times as long as the retention time of levofloxacin, beginning after the solvent peak.

System suitability—

Test for required detectability: Pipet 1 mL of the standard solution, and add a mixture of water and methanol (1:1) to make exactly 20 mL. Confirm that the peak area of levofloxacin obtained with 10 μL of this solution is equivalent to 4 to 6% of that with 10 μL of the standard solution.

System performance: Dissolve 10 mg of ofloxacin in 20 mL of a mixture of water and methanol (1:1). To 1 mL of this solution add a mixture of water and methanol (1:1) to make 10 mL. When the procedure is run with 10 μL of this solution under the above operating conditions, the resolution between the peaks of levofloxacin and the enantiomer is not less than 3.

System repeatability: When the test is repeated 6 times with 10 μL of the standard solution under the above operat-

ing conditions, the relative standard deviation of the peak area of levofloxacin is not more than 3.0%.

Water <2.48> 2.1 – 2.7% (0.5 g, volumetric titration, direct titration).

Residue on ignition <2.44> Not more than 0.1% (1 g, platinum crucible).

Assay Weigh accurately about 0.3 g of Levofloxacin Hydrate, dissolve in 100 mL of acetic acid (100), and titrate <2.50> with 0.1 mol/L perchloric acid VS (potentiometric titration). Perform a blank determination in the same manner, and make any necessary correction.

Each mL of 0.1 mol/L perchloric acid VS
= 36.14 mg of $C_{18}H_{20}FN_3O_4$

Containers and storage Containers—Tight containers.

Storage—Light-resistant.

Levofloxacin Fine Granules

レボフロキサシン細粒

Levofloxacin Fine Granules contain not less than 93.0% and not more than 107.0% of the labeled amount of levofloxacin ($C_{18}H_{20}FN_3O_4$: 361.37).

Method of preparation Prepare as directed under Granules, with Levofloxacin Hydrate.

Identification To an amount of Levofloxacin Fine Granules, equivalent to 50 mg of levofloxacin ($C_{18}H_{20}FN_3O_4$), add diluted 3 mol/L hydrochloric acid TS (1 in 100) to make 50 mL, and stir for 20 minutes. Filter this solution through a membrane filter with a pore size not exceeding 0.45 μm , discard the first 10 mL of the filtrate, and to 1 mL of the subsequent filtrate add diluted 3 mol/L hydrochloric acid TS (1 in 100) to make 100 mL. Determine the absorption spectrum of this solution as directed under Ultraviolet-visible Spectrophotometry <2.24>: it exhibits maxima between 225 nm and 229 nm and between 292 nm and 296 nm, and a shoulder between 321 nm and 331 nm.

Uniformity of dosage units <6.02> Perform the test according to the following method: the Granules in single-dose packages meet the requirement of the Content uniformity test.

To the total amount of the content of 1 package of Levofloxacin Fine Granules add diluted 3 mol/L hydrochloric acid TS (1 in 100) to make exactly V mL so that each mL contains about 1 mg of levofloxacin ($C_{18}H_{20}FN_3O_4$), and stir for 20 minutes. Filter this solution through a membrane filter with a pore size not exceeding 0.45 μm . Discard the first 10 mL of the filtrate, pipet 1 mL of the subsequent filtrate, add diluted 3 mol/L hydrochloric acid TS (1 in 100) to make exactly 100 mL, and use this solution as the sample solution. Separately, weigh accurately about 25 mg of levofloxacin hydrate for assay (separately determine the water <2.48> in the same manner as Levofloxacin Hydrate), and dissolve in diluted 3 mol/L hydrochloric acid TS (1 in 100) to make exactly 50 mL. Pipet 2 mL of this solution, add diluted 3 mol/L hydrochloric acid TS (1 in 100) to make exactly 100 mL, and use this solution as the standard solution. Determine the absorbances, A_T and A_S , at 327 nm of the sample solution and standard solution as directed under Ultraviolet-visible Spectrophotometry <2.24>.

Amount (mg) of levofloxacin ($C_{18}H_{20}FN_3O_4$)
= $M_S \times A_T/A_S \times V/25$

M_S : Amount (mg) of levofloxacin hydrate for assay taken, calculated on the anhydrous basis

Dissolution <6.10> When the test is performed at 75 revolutions per minute according to the Paddle method, using 900 mL of water as the dissolution medium, the dissolution rate in 90 minutes of Levofloxacin Fine Granules is not less than 70%.

Start the test with an accurately weighed amount of Levofloxacin Fine Granules, equivalent to about 0.1 g of levofloxacin ($C_{18}H_{20}FN_3O_4$), withdraw not less than 20 mL of the medium at the specified minute after starting the test, and filter through a membrane filter with a pore size not exceeding 0.45 μm . Discard not less than 10 mL of the first filtrate, pipet 5 mL of the subsequent filtrate, add water to make exactly 100 mL, and use this solution as the sample solution. Separately, weigh accurately about 28 mg of levofloxacin hydrate for assay (separately determine the water <2.48> in the same manner as Levofloxacin Hydrate), and dissolve in water to make exactly 100 mL. Pipet 2 mL of this solution, add water to make exactly 100 mL, and use this solution as the standard solution. Determine the absorbances, A_T and A_S , at 289 nm of the sample solution and standard solution as directed under Ultraviolet-visible Spectrophotometry <2.24>.

Dissolution rate (%) with respect to the labeled amount of levofloxacin ($C_{18}H_{20}FN_3O_4$)

= $M_S/M_T \times A_T/A_S \times 1/C \times 360$

M_S : Amount (mg) of levofloxacin hydrate for assay taken, calculated on the anhydrous basis

M_T : Amount (g) of Levofloxacin Fine Granules taken

C : Labeled amount (mg) of levofloxacin ($C_{18}H_{20}FN_3O_4$) in 1 g

Assay Weigh accurately an amount of Levofloxacin Fine Granules, powder if necessary, equivalent to about 50 mg of levofloxacin ($C_{18}H_{20}FN_3O_4$), add diluted 3 mol/L hydrochloric acid TS (1 in 100) to make exactly 50 mL, stir for 20 minutes, and filter this solution through a membrane filter with a pore size not exceeding 0.45 μm . Discard the first 10 mL of the filtrate, pipet 5 mL of the subsequent filtrate, add diluted 3 mol/L hydrochloric acid TS (1 in 100) to make exactly 100 mL, and use this solution as the sample solution. Separately, weigh accurately about 50 mg of levofloxacin hydrate for assay (separately determine the water <2.48> in the same manner as Levofloxacin Hydrate), and dissolve in diluted 3 mol/L hydrochloric acid TS (1 in 100) to make exactly 50 mL. Pipet 5 mL of this solution, add diluted 3 mol/L hydrochloric acid TS (1 in 100) to make exactly 100 mL, and use this solution as the standard solution. Perform the test with exactly 10 μL each of the sample solution and standard solution as directed under Liquid Chromatography <2.01> according to the following conditions, and determine the peak areas, A_T and A_S , of levofloxacin in each solution.

Amount (mg) of levofloxacin ($C_{18}H_{20}FN_3O_4$)
= $M_S \times A_T/A_S$

M_S : Amount (mg) of levofloxacin hydrate for assay taken, calculated on the anhydrous basis

Operating conditions—

Detector: An ultraviolet absorption photometer (wavelength: 340 nm).

Column: A stainless steel column 4.6 mm in inside diameter and 15 cm in length, packed with octadecylsilanized silica

gel for liquid chromatography (5 μm in particle diameter).

Column temperature: A constant temperature of about 45°C.

Mobile phase: Dissolve 1.00 g of copper (II) sulfate pentahydrate, 1.41 g of L-valine and 6.17 g of ammonium acetate in 800 mL of water, and add 200 mL of methanol.

Flow rate: Adjust so that the retention time of levofloxacin is about 20 minutes.

System suitability—

System performance: Dissolve 10 mg of ofloxacin in 20 mL of diluted 3 mol/L hydrochloric acid TS (1 in 100). To 1 mL of this solution add diluted 3 mol/L hydrochloric acid TS (1 in 100) to make 20 mL. When the procedure is run with 10 μL of this solution under the above operating conditions, levofloxacin and an enantiomer are eluted in this order with the resolution between these peaks being not less than 3.

System repeatability: When the test is repeated 6 times with 10 μL of the standard solution under the above operating conditions, the relative standard deviation of the peak area of levofloxacin is not more than 1.0%.

Containers and storage Containers—Tight containers.

Storage—Light-resistant.

Levofloxacin Injection

レボフロキサシン注射液

Levofloxacin Injection is an aqueous injection.

It contains not less than 95.0% and not more than 105.0% of the labeled amount of levofloxacin ($\text{C}_{18}\text{H}_{20}\text{FN}_3\text{O}_4$; 361.37).

Method of preparation Prepare as directed under Injections, with Levofloxacin Hydrate.

Description Levofloxacin Injection is yellow to greenish yellow, clear liquid.

Identification To a volume of Levofloxacin Injection, equivalent to 50 mg of levofloxacin ($\text{C}_{18}\text{H}_{20}\text{FN}_3\text{O}_4$), add diluted 1 mol/L hydrochloric acid TS (3 in 100) to make 50 mL. To 1 mL of this solution add diluted 1 mol/L hydrochloric acid TS (3 in 100) to make 100 mL. Determine the absorption spectrum of this solution as directed under Ultraviolet-visible Spectrophotometry <2.24>: it exhibits maxima between 225 nm and 229 nm and between 292 nm and 296 nm, and a shoulder between 321 nm and 331 nm.

pH Being specified separately when the drug is granted approval based on the Law.

Bacterial endotoxin <4.01> Less than 0.60 EU/mg.

Extractable volume <6.05> It meets the requirement.

Foreign insoluble matter <6.06> Perform the test according to Method 1: it meets the requirement.

Insoluble particulate matter <6.07> It meets the requirement.

Sterility <4.06> Perform the test according to the Membrane filtration method: it meets the requirement.

Assay To an exact volume of Levofloxacin Injection, equivalent to about 50 mg of levofloxacin ($\text{C}_{18}\text{H}_{20}\text{FN}_3\text{O}_4$), add diluted 1 mol/L hydrochloric acid TS (3 in 100) to make exactly 50 mL. Pipet 5 mL of this solution, add diluted 1 mol/L hydrochloric acid TS (3 in 100) to make exactly 100 mL, and use this solution as the sample solution. Separately,

weigh accurately about 50 mg of levofloxacin hydrate for assay (separately determine the water <2.48> in the same manner as Levofloxacin Hydrate), and dissolve in diluted 1 mol/L hydrochloric acid TS (3 in 100) to make exactly 50 mL. Pipet 5 mL of this solution, add diluted 1 mol/L hydrochloric acid TS (3 in 100) to make exactly 100 mL, and use this solution as the standard solution. Perform the test with exactly 10 μL each of the sample solution and standard solution as directed under Liquid Chromatography <2.01> according to the following conditions, and determine the peak areas, A_T and A_S , of levofloxacin in each solution.

$$\begin{aligned} &\text{Amount (mg) of levofloxacin (C}_{18}\text{H}_{20}\text{FN}_3\text{O}_4) \\ &= M_S \times A_T / A_S \end{aligned}$$

M_S : Amount (mg) of levofloxacin for assay taken, calculated on the anhydrous basis

Operating conditions—

Detector, column, and column temperature: Proceed as directed in the operating conditions in the Purity (2) under Levofloxacin Hydrate.

Mobile phase: Dissolve 1.00 g of copper (II) sulfate pentahydrate, 1.41 g of L-valine and 6.17 g of ammonium acetate in 800 mL of water, and add 200 mL of methanol.

Flow rate: Adjust so that the retention time of levofloxacin is about 20 minutes.

System suitability—

System performance: Dissolve 10 mg of ofloxacin in 20 mL of diluted 1 mol/L hydrochloric acid TS (3 in 100). To 1 mL of this solution add diluted 1 mol/L hydrochloric acid TS (3 in 100) to make 20 mL. When the procedure is run with 10 μL of this solution under the above operating conditions, levofloxacin and the enantiomer are eluted in this order with the resolution between these peaks being not less than 3.

System repeatability: When the test is repeated 6 times with 10 μL of the standard solution under the above operating conditions, the relative standard deviation of the peak area of levofloxacin is not more than 1.0%.

Containers and storage Containers—Hermetic containers. Plastic containers for aqueous injections may be used.

Levofloxacin Ophthalmic Solution

レボフロキサシン点眼液

Levofloxacin Ophthalmic Solution is an aqueous ophthalmic preparation.

It contains not less than 95.0% and not more than 107.0% of the labeled amount of levofloxacin hydrate ($\text{C}_{18}\text{H}_{20}\text{FN}_3\text{O}_4 \cdot \frac{1}{2}\text{H}_2\text{O}$; 370.38).

Method of preparation Prepare as directed under Ophthalmic Liquids and Solutions, with Levofloxacin Hydrate.

Description Levofloxacin Ophthalmic Solution occurs as a clear, pale yellow to yellow liquid.

Identification (1) To a volume of Levofloxacin Ophthalmic Solution, equivalent to 5 mg of Levofloxacin Hydrate, add 0.01 mol/L hydrochloric acid TS to make 100 mL. To 2 mL of this solution add 0.01 mol/L hydrochloric acid TS to make 20 mL, and use this solution as the sample solution. Determine the absorption spectrum of the sample solution as directed under Ultraviolet-visible Spectrophotometry <2.24>: it exhibits maxima between 225 nm and 229 nm, and between 292 nm and 296 nm.

(2) To a volume of Levofloxacin Ophthalmic Solution, equivalent to 5 mg of Levofloxacin Hydrate, add a mixture of water and methanol (1:1) to make 5 mL, and use this solution as the sample solution. Separately, dissolve 10 mg of levofloxacin hydrate for assay in 10 mL of a mixture of water and methanol (1:1), and use this solution as the standard solution. Perform the test with 10 μ L each of the sample solution and standard solution as directed under Liquid Chromatography <2.01> according to the following conditions: the retention time of the principal peaks in the chromatogram obtained from the sample solution and the standard solution is the same.

Operating conditions—

Detector: An ultraviolet absorption photometer (wavelength: 340 nm).

Column: A stainless steel column 4.6 mm in inside diameter and 15 cm in length, packed with octadecylsilanized silica gel for liquid chromatography (5 μ m in particle diameter).

Column temperature: A constant temperature of about 45°C.

Mobile phase: Dissolve 1.25 g of copper (II) sulfate pentahydrate, 1.76 g of L-valine and 7.71 g of ammonium acetate in water to make 1000 mL, and add 250 mL of methanol.

Flow rate: Adjust so that the retention time of levofloxacin is about 22 minutes.

System suitability—

System performance: Dissolve 10 mg of ofloxacin in 20 mL of a mixture of water and methanol (1:1). To 1 mL of this solution add a mixture of water and methanol (1:1) to make 10 mL. When the procedure is run with 10 μ L of this solution under the above operating conditions, the resolution between the peak of levofloxacin and the peak having the relative retention time of about 1.2 to levofloxacin is not less than 3.

Osmotic pressure ratio Being specified separately when the drug is granted approval based on the Law.

pH Being specified separately when the drug is granted approval based on the Law.

Foreign insoluble matter <6.11> It meets the requirement.

Insoluble particulate matter <6.08> It meets the requirement.

Sterility <4.06> Perform the test according to the Membrane filtration method: it meets the requirement.

Assay To an exact volume of Levofloxacin Ophthalmic Solution, equivalent to about 5 mg of levofloxacin hydrate ($C_{18}H_{20}FN_3O_4 \cdot \frac{1}{2}H_2O$) add exactly 2 mL of the internal standard solution, then add the mobile phase to make 100 mL, and use this solution as the sample solution. Separately, weigh accurately about 25 mg of levofloxacin hydrate for assay (separately determine the water <2.48> in the same manner as Levofloxacin Hydrate), and dissolve in water to make exactly 50 mL. Pipet 10 mL of this solution, add exactly 2 mL of the internal standard solution, then add the mobile phase to make 100 mL, and use this solution as the standard solution. Perform the test with 10 μ L each of the sample solution and standard solution as directed under Liquid Chromatography <2.01> according to the following conditions, and calculate the ratios, Q_T and Q_S , of the peak area of levofloxacin to that of the internal standard.

Amount (mg) of levofloxacin hydrate ($C_{18}H_{20}FN_3O_4 \cdot \frac{1}{2}H_2O$)
 $= M_S \times Q_T / Q_S \times 1/5 \times 1.025$

M_S : Amount (mg) of levofloxacin hydrate for assay taken, calculated on the anhydrous basis

Internal standard solution—A solution of naphazoline hydrochloride in the mobile phase (3 in 500).

Operating conditions—

Detector: An ultraviolet absorption photometer (wavelength: 280 nm).

Column: A stainless steel column 4 mm in inside diameter and 15 cm in length, packed with octadecylsilanized silica gel for liquid chromatography (5 μ m in particle diameter).

Column temperature: A constant temperature of about 40°C.

Mobile phase: Dissolve 13.61 g of potassium dihydrogen phosphate and 0.77 g of ammonium acetate in 900 mL of water, adjust to pH 3.0 with 1 mol/L hydrochloric acid TS, and add water to make 1000 mL. To 900 mL of this solution add 100 mL of acetonitrile.

Flow rate: Adjust so that the retention time of levofloxacin is about 17 minutes.

System suitability—

System performance: When the procedure is run with 10 μ L of the standard solution under the above operating conditions, levofloxacin and the internal standard are eluted in this order with the resolution between these peaks being not less than 5.

System repeatability: When the test is repeated 6 times with 10 μ L of the standard solution under the above operating conditions, the relative standard deviation of the ratio of the peak area of levofloxacin to that of the internal standard is not more than 1.0%.

Containers and storage Containers—Tight containers.

Storage—Light-resistant.

Levofloxacin Tablets

レボフロキサシン錠

Levofloxacin Tablets contain not less than 95.0% and not more than 105.0% of the labeled amount of levofloxacin ($C_{18}H_{20}FN_3O_4$; 361.37).

Method of preparation Prepare as directed under Tablets, with Levofloxacin Hydrate.

Identification To an amount of powdered Levofloxacin Tablets, equivalent to 0.1 g of levofloxacin ($C_{18}H_{20}FN_3O_4$), add diluted 3 mol/L hydrochloric acid TS (1 in 100) to make 100 mL, and stir for 20 minutes. Filter this solution through a membrane filter with a pore size not exceeding 0.45 μ m, discard the first 10 mL of the filtrate, and to 1 mL of the subsequent filtrate add diluted 3 mol/L hydrochloric acid TS (1 in 100) to make 100 mL. Determine the absorption spectrum of this solution as directed under Ultraviolet-visible Spectrophotometry <2.24>: it exhibits maxima between 225 nm and 229 nm and between 292 nm and 296 nm, and a shoulder between 321 nm and 331 nm.

Uniformity of dosage units <6.02> Perform the Mass variation test, or the Content uniformity test according to the following method: it meets the requirement.

To 1 tablet of Levofloxacin Tablets add about 70 mL of diluted 3 mol/L hydrochloric acid TS (1 in 100), sonicate to disintegrate the tablet, add diluted 3 mol/L hydrochloric acid TS (1 in 100) to make exactly 100 mL, and stir for 20 minutes. Pipet V mL the solution, add diluted 3 mol/L hydrochloric acid TS (1 in 100) to make exactly V' mL so that each mL contains about 50 μ g of levofloxacin ($C_{18}H_{20}FN_3O_4$), and filter this solution through a membrane

filter with a pore size not exceeding 0.45 μm . Discard the first 10 mL of the filtrate, and use the subsequent filtrate as the sample solution. Then, proceed as directed in the Assay.

$$\begin{aligned} & \text{Amount (mg) of levofloxacin (C}_{18}\text{H}_{20}\text{FN}_3\text{O}_4) \\ & = M_S \times A_T/A_S \times V'/V \times 1/5 \end{aligned}$$

M_S : Amount (mg) of levofloxacin hydrate for assay taken, calculated on the anhydrous basis

Dissolution <6.10> (1) For a 100-mg Tablet When the test is performed at 50 revolutions per minute according to the Paddle method, using 900 mL of water as the dissolution medium, the dissolution rate in 90 minutes is not less than 80%.

Start the test with 1 tablet of Levofloxacin Tablets, withdraw not less than 20 mL of the medium at the specified minute after starting the test, and filter through a membrane filter with a pore size not exceeding 0.45 μm . Discard not less than 10 mL of the first filtrate, pipet 5 mL of the subsequent filtrate, add water to make exactly 100 mL, and use this solution as the sample solution. Separately, weigh accurately about 28 mg of levofloxacin hydrate for assay (separately determine the water <2.48> in the same manner as Levofloxacin Hydrate), and dissolve in water to make exactly 100 mL. Pipet 2 mL of this solution, add water to make exactly 100 mL, and use this solution as the standard solution. Determine the absorbances, A_T and A_S , at 289 nm of the sample solution and standard solution as directed under Ultraviolet-visible Spectrophotometry <2.24>.

$$\begin{aligned} & \text{Dissolution rate (\%)} \text{ with respect to the labeled amount} \\ & \text{of levofloxacin hydrate (C}_{18}\text{H}_{20}\text{FN}_3\text{O}_4 \cdot \frac{1}{2}\text{H}_2\text{O}) \\ & = M_S \times A_T/A_S \times 18/5 \times 1.025 \end{aligned}$$

M_S : Amount (mg) of levofloxacin hydrate for assay taken, calculated on the anhydrous basis

(2) For a 250-mg Tablet and 500-mg Tablet When the tests are performed at 50 revolutions per minute according to the Paddle method, using 900 mL of 2nd fluid for dissolution test as the dissolution medium, the dissolution rate in 30 minutes is not less than 80%.

Start the test with 1 tablet of Levofloxacin Tablets, withdraw not less than 20 mL of the medium at the specified minute after starting the test, and filter through a membrane filter with a pore size not exceeding 0.45 μm . Discard not less than 10 mL of the first filtrate, pipet V mL of the subsequent filtrate, add the dissolution medium to make exactly V' mL so that each mL contains about 11.2 μg of levofloxacin ($\text{C}_{18}\text{H}_{20}\text{FN}_3\text{O}_4$), and use this solution as the sample solution. Separately, weigh accurately about 28 mg of levofloxacin hydrate for assay (separately determine the water <2.48> in the same manner as Levofloxacin Hydrate), and dissolve in the dissolution medium to make exactly 50 mL. Pipet 2 mL of this solution, add the dissolution medium to make exactly 100 mL, and use this solution as the standard solution. Determine the absorbances, A_T and A_S , at 287 nm of the sample solution and standard solution as directed under Ultraviolet-visible Spectrophotometry <2.24>.

$$\begin{aligned} & \text{Dissolution rate (\%)} \text{ with respect to the labeled amount} \\ & \text{of levofloxacin (C}_{18}\text{H}_{20}\text{FN}_3\text{O}_4) \\ & = M_S \times A_T/A_S \times V'/V \times 1/C \times 36 \end{aligned}$$

M_S : Amount (mg) of levofloxacin hydrate for assay taken, calculated on the anhydrous basis

C : Amount (mg) of levofloxacin ($\text{C}_{18}\text{H}_{20}\text{FN}_3\text{O}_4$) in 1 g

Assay Accurately weigh the mass of not less than 20 Levofloxacin Tablets, and powder them. Weigh accurately a

portion of the powder, equivalent to about 1 g of levofloxacin ($\text{C}_{18}\text{H}_{20}\text{FN}_3\text{O}_4$), add 150 mL of diluted 3 mol/L hydrochloric acid TS (1 in 100), sonicate for 5 minutes, and add diluted 3 mol/L hydrochloric acid TS (1 in 100) to make exactly 200 mL, and stir for 10 minutes. Pipet 2 mL of this solution, add diluted 3 mol/L hydrochloric acid TS (1 in 100) to make exactly 200 mL, and filter through a membrane filter with a pore size not exceeding 0.45 μm . Discard the first 10 mL of the filtrate, and use the subsequent filtrate as the sample solution. Separately, weigh accurately about 25 mg of levofloxacin hydrate for assay (separately determine the water <2.48> in the same manner as Levofloxacin Hydrate), and dissolve in diluted 3 mol/L hydrochloric acid TS (1 in 100) to make exactly 50 mL. Pipet 2 mL of this solution, add diluted 3 mol/L hydrochloric acid TS (1 in 100) to make exactly 20 mL, and use this solution as the standard solution. Perform the test with exactly 10 μL each of the sample solution and standard solution as directed under Liquid Chromatography <2.01> according to the following conditions, and determine the peak areas, A_T and A_S , of levofloxacin in each solution.

$$\begin{aligned} & \text{Amount (mg) of levofloxacin (C}_{18}\text{H}_{20}\text{FN}_3\text{O}_4) \\ & = M_S \times A_T/A_S \times 40 \end{aligned}$$

M_S : Amount (mg) of levofloxacin hydrate for assay taken, calculated on the anhydrous basis

Operating conditions—

Detector: An ultraviolet absorption photometer (wavelength: 340 nm).

Column: A stainless steel column 4.6 mm in inside diameter and 15 cm in length, packed with octadecylsilanized silica gel for liquid chromatography (5 μm in particle diameter).

Column temperature: A constant temperature of about 45°C.

Mobile phase: Dissolve 1.00 g of copper (II) sulfate pentahydrate, 1.41 g of L-valine and 6.17g of ammonium acetate in 800 mL of water, and add 200 mL of methanol.

Flow rate: Adjust so that the retention time of levofloxacin is about 20 minutes.

System suitability—

System performance: Dissolve 10 mg of ofloxacin in 20 mL of diluted 3 mol/L hydrochloric acid TS (1 in 100). To 1 mL of this solution add diluted 3 mol/L hydrochloric acid TS (1 in 100) to make 20 mL. When the procedure is run with 10 μL of this solution under the above operating conditions, levofloxacin and an enantiomer are eluted in this order with the resolution between these peaks being not less than 3.

System repeatability: When the test is repeated 6 times with 10 μL of the standard solution under the above operating conditions, the relative standard deviation of the peak area of levofloxacin is not more than 1.0%.

Containers and storage Containers—Tight containers.

Levomepromazine Maleate

レボメプロマジンマレイン酸塩

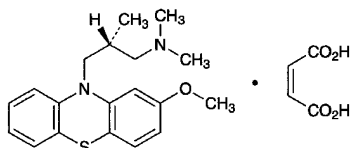

$C_{19}H_{24}N_2OS \cdot C_4H_4O_4$: 444.54
(2*R*)-3-(2-Methoxy-10*H*-phenothiazin-10-yl)-*N,N*,2-trimethylpropylamine monomaleate
[7104-38-3]

Levomepromazine Maleate, when dried, contains not less than 98.0% of levomepromazine maleate ($C_{19}H_{24}N_2OS \cdot C_4H_4O_4$).

Description Levomepromazine Maleate occurs as white, crystals or crystalline powder. It is odorless, and has a slightly bitter taste.

It is freely soluble in acetic acid (100), soluble in chloroform, sparingly soluble in methanol, slightly soluble in ethanol (95) and in acetone, very slightly soluble in water, and practically insoluble in diethyl ether.

Melting point: 184 – 190°C (with decomposition).

Identification (1) Dissolve 5 mg of Levomepromazine Maleate in 5 mL of sulfuric acid: a red-purple color develops, which slowly becomes deep red-purple. To this solution add 1 drop of potassium dichromate TS: a brownish yellow-red color is produced.

(2) To 0.2 g of Levomepromazine Maleate add 5 mL of sodium hydroxide TS and 20 mL of diethyl ether, and shake well. Separate the diethyl ether layer, wash twice with 10-mL portions of water, add 0.5 g of anhydrous sodium sulfate, filter, evaporate the diethyl ether on a water bath, and dry the residue at 105°C for 2 hours: the residue melts <2.60> between 124°C and 128°C.

(3) To 0.5 g of Levomepromazine Maleate add 5 mL of water and 2 mL of ammonia solution (28), extract with three 5-mL portions of chloroform, separate and evaporate the water layer to dryness. To the residue add 2 to 3 drops of dilute sulfuric acid and 5 mL of water, and extract with four 25-mL portions of diethyl ether. Combine all the diethyl ether extracts, evaporate the diethyl ether in a water bath at a temperature of about 35°C with the aid of a current of air: the residue melts <2.60> between 128°C and 136°C.

Optical rotation <2.49> $[\alpha]_D^{20}$: –13.5 – –16.5° (after drying, 0.5 g, chloroform, 20 mL, 200 mm).

Purity (1) Clarity and color of solution—To 0.5 g of Levomepromazine Maleate add 10 mL of methanol, and dissolve by warming: the solution is clear, and colorless or pale yellow.

(2) Chloride <1.03>—Dissolve 0.5 g of Levomepromazine Maleate in 40 mL of methanol, and add 6 mL of dilute nitric acid and water to make 50 mL. Perform the test using this solution as the test solution. Prepare the control solution with 0.40 mL of 0.01 mol/L hydrochloric acid VS, 40 mL of methanol, 6 mL of dilute nitric acid and water to make 50 mL (not more than 0.028%).

(3) Heavy metals <1.07>—Proceed with 2.0 g of Levomepromazine Maleate according to Method 2, and perform the test. Prepare the control solution with 2.0 mL of Standard Lead Solution (not more than 10 ppm).

Loss on drying <2.41> Not more than 0.5% (2 g, 105°C, 3 hours).

Residue on ignition <2.44> Not more than 0.1% (1 g).

Assay Weigh accurately about 1 g of Levomepromazine Maleate, previously dried, and dissolve in a mixture of 40 mL of acetic acid (100) and 20 mL of acetone for nonaqueous titration. Titrate <2.50> with 0.1 mol/L perchloric acid VS until the color of the solution changes from red-purple through blue-purple to blue (indicator: 5 drops of bromocresol green-methylrosaniline chloride TS). Perform a blank determination in the same manner, and make any necessary correction.

Each mL of 0.1 mol/L perchloric acid VS
= 44.45 mg of $C_{19}H_{24}N_2OS \cdot C_4H_4O_4$

Containers and storage Containers—Tight containers.
Storage—Light-resistant.

Levothyroxine Sodium Hydrate

レボチロキシナトリウム水和物

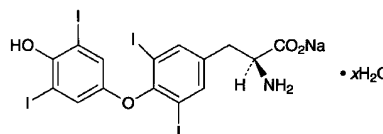

$C_{15}H_{10}I_4NNaO_4 \cdot xH_2O$
Monosodium *O*-(4-hydroxy-3,5-diiodophenyl)-3,5-diiodo-L-tyrosinate hydrate
[25416-65-3]

Levothyroxine Sodium Hydrate contains not less than 97.0% of levothyroxine sodium ($C_{15}H_{10}I_4NNaO_4$: 798.85), calculated on the dried basis.

Description Levothyroxine Sodium Hydrate occurs as a pale yellow-white to light yellow-brown powder. It is odorless.

It is slightly soluble in ethanol (95), and practically insoluble in water and in diethyl ether.

It dissolves in sodium hydroxide TS.

It is gradually colored by light.

Identification (1) Heat 0.1 g of Levothyroxine Sodium Hydrate over a flame: a purple gas evolves.

(2) To 0.5 mg of Levothyroxine Sodium Hydrate add 8 mL of a mixture of water, ethanol (95), hydrochloric acid and sodium hydroxide TS (6:5:2:2), warm in a water bath for 2 minutes, cool, and add 0.1 mL of sodium nitrite TS. Allow to stand in a dark place for 20 minutes, and add 1.5 mL of ammonia solution (28): a yellowish red color is produced.

(3) Determine the absorption spectrum of a solution of Levothyroxine Sodium Hydrate in dilute sodium hydroxide TS (1 in 10,000) as directed under Ultraviolet-visible Spectrophotometry <2.24>, and compare the spectrum with the Reference Spectrum: both spectra exhibit similar intensities of absorption at the same wavelengths.

(4) Moisten Levothyroxine Sodium Hydrate with sulfuric acid, and ignite: the residue responds to Qualitative Tests <1.09> (1) and (2) for sodium salt.

Optical rotation <2.49> $[\alpha]_D^{20}$: –5 – –6° (0.3 g calculated on the dried basis, a mixture of ethanol (95) and sodium hydroxide TS (2:1), 10 mL, 100 mm).

Purity (1) Clarity and color of solution—Dissolve 0.3 g of Levothyroxine Sodium Hydrate in 10 mL of a mixture of ethanol (95) and sodium hydroxide TS (2:1) by warming; the solution is clear and pale yellow to pale yellow-brown in color.

(2) Soluble halides—Dissolve 0.01 g of Levothyroxine Sodium Hydrate in 10 mL of water and 1 drop of dilute nitric acid, shake for 5 minutes, and filter. To the filtrate add water to make 10 mL, then add 3 drops of silver nitrate TS, and mix: the solution has no more opalescence than the following control solution.

Control solution: To 0.20 mL of 0.01 mol/L hydrochloric acid VS add 10 mL of water and 1 drop of dilute nitric acid, and proceed as directed above.

(3) Related substances—Dissolve 20 mg of Levothyroxine Sodium Hydrate in 2 mL of a mixture of ethanol (95) and ammonia solution (28) (14:1), and use this solution as the sample solution. Pipet 1 mL of the sample solution, add a mixture of ethanol (95) and ammonia solution (28) (14:1) to make exactly 50 mL, and use this solution as the standard solution. Perform the test with these solutions as directed under Thin-layer Chromatography <2.03>. Spot 5 μ L each of the sample solution and standard solution on a plate of silica gel for thin-layer chromatography. Develop the plate with a mixture of *t*-butyl alcohol, *t*-amyl alcohol, water, ammonia solution (28) and 2-butanone (59:32:17:15:7) to a distance of about 12 cm, and air-dry the plate. Spray evenly a solution of 0.3 g of ninhydrin in 100 mL of a mixture of 1-butanol and acetic acid (100) (97:3) on the plate, and heat the plate at 100°C for 3 minutes: the red-purple spots other than the principal spot obtained from the sample solution are not more intense than the spot from the standard solution.

Loss on drying <2.41> 7–11% (0.5 g, in vacuum, phosphorus (V) oxide, 60°C, 4 hours).

Assay Weigh accurately about 25 mg of Levothyroxine Sodium Hydrate, and proceed as directed under Oxygen Flask Combustion Method <1.06>, using a mixture of 10 mL of sodium hydroxide solution (1 in 100) and 1 mL of a freshly prepared sodium bisulfate solution (1 in 100) as the absorbing liquid, and prepare the test solution. Apply a small amount of water to the upper part of apparatus A, pull out C carefully, and wash C, B and the inner wall of A with 40 mL of water. To the test solution add 1 mL of bromine-acetic acid TS, insert the stopper C, and shake vigorously for 1 minute. Remove the stopper, rinse the stopper, the sample holder and the inner wall of the flask with 40 mL of water, and add 0.5 mL of formic acid. Stopper the flask with C, and shake vigorously for 1 minute again. Remove the stopper, and rinse the stopper, the sample holder and the inner wall of the flask with 40 mL of water. Bubble the solution with enough nitrogen gas in the flask to remove the oxygen and excess bromine, add 0.5 g of potassium iodide to the solution, and dissolve. Add immediately 3 mL of dilute sulfuric acid, mix, and allow to stand for 2 minutes. Titrate <2.50> the solution with 0.02 mol/L sodium thiosulfate VS (indicator: 3 mL of starch TS). Perform a blank determination in the same manner, and make any necessary correction.

Each mL of 0.02 mol/L sodium thiosulfate VS
= 0.6657 mg of $C_{15}H_{10}I_4NNaO_4$

Containers and storage Containers—Tight containers.
Storage—Light-resistant.

Levothyroxine Sodium Tablets

レボチロキシナトリウム錠

Levothyroxine Sodium Tablets contain not less than 90.0% and not more than 110.0% of the labeled amount of levothyroxine sodium ($C_{15}H_{10}I_4NNaO_4$; 798.85).

Method of preparation Prepare as directed under Tablets, with Levothyroxine Sodium Hydrate.

Identification (1) Weigh a quantity of powdered Levothyroxine Sodium Tablets, equivalent to 0.5 mg of Levothyroxine Sodium Hydrate, add 8 mL of a mixture of water, ethanol (95), hydrochloric acid and sodium hydroxide TS (6:5:2:2), warm in a water bath for 2 minutes, cool, and filter. To the filtrate add 0.1 mL of sodium nitrite TS, and allow to stand in a dark place for 20 minutes. Add 1.5 mL of ammonia solution (28): a yellowish red color develops.

(2) To a quantity of powdered Levothyroxine Sodium Tablets, equivalent to 1 mg of Levothyroxine Sodium Hydrate, add 10 mL of ethanol (95), shake, filter, and use the filtrate as the sample solution. Dissolve 0.01 g of levothyroxine sodium for thin-layer chromatography in 100 mL of ethanol (95), and use this solution as the standard solution. Perform the test with these solutions as directed under Thin-layer Chromatography <2.03>. Spot 20 μ L each of the sample solution and standard solution on a plate of silica gel for thin-layer chromatography. Develop the plate with a mixture of *t*-butyl alcohol, *t*-amyl alcohol, water, ammonia solution (28) and 2-butanone (59:32:17:15:7) to a distance of about 12 cm, and air-dry the plate. Spray evenly a solution of 0.3 g of ninhydrin in 100 mL of a mixture of 1-butanol and acetic acid (100) (97:3) on the plate, and heat the plate at 100°C for 3 minutes: the spots obtained from the sample solution and the standard solution show a red-purple color, and has the same *R_f* value.

Purity Soluble halides—Weigh a quantity of powdered Levothyroxine Sodium Tablets, equivalent to 2.5 mg of Levothyroxine Sodium Hydrate, add 25 mL of water, warm to 40°C, shake for 5 minutes, add 3 drops of dilute nitric acid, and filter. To the filtrate add 3 drops of silver nitrate TS, and mix: the solution has no more opalescence than the following control solution.

Control solution: To 0.25 mL of 0.01 mol/L hydrochloric acid VS add 25 mL of water and 3 drops of dilute nitric acid, and proceed as directed above.

Uniformity of dosage units <6.02> Perform the test according to the following method: it meets the requirement of the Content uniformity test.

Place 1 tablet of Levothyroxine Sodium Tablets in a glass-stoppered centrifuge tube, add exactly 10 mL of 0.01 mol/L sodium hydroxide TS, warm at 50°C for 15 minutes, and shake vigorously for 20 minutes. Centrifuge this solution, pipet 5 mL of the supernatant liquid, add exactly 1 mL of the internal standard solution, and use this solution as the sample solution. Perform the test with 20 μ L of the sample solution as directed under Liquid Chromatography <2.01> according to the following conditions, and calculate the ratio of the peak area of levothyroxine to that of the internal standard. Calculate the mean value from the ratios of each peak area of 10 samples: the deviation (%) of the mean value and the ratio of each peak area should be not more than 15%. When the deviation (%) is more than 15%, and 1 sam-

ple shows not more than 25%, perform another test with 20 samples. Calculate the deviation (%) of the mean value of the 30 samples used in the 2 tests and the ratio of each peak area: there should be not more than 1 sample with the deviation more than 15% but not more than 25%, and no sample should deviate by more than 25%.

Internal standard solution—A solution of ethinylestradiol in a mixture of acetonitrile and diluted phosphoric acid (1 in 10) (9:1) (3 in 40,000).

Operating conditions—

Detector: An ultraviolet absorption photometer (wavelength: a constant wavelength between 220 nm and 230 nm).

Column: A stainless steel column 4 to 6 mm in inside diameter and 10 to 25 cm in length, packed with octadecylsilylanized silica gel (5 μ m in particle diameter).

Column temperature: A constant temperature at about 25°C.

Mobile phase: A mixture of methanol, water and phosphoric acid (1340:660:1).

Flow rate: Adjust so that the retention time of levothyroxine is about 9 minutes.

Selection of column: To 5 mL of a solution of levothyroxine sodium in 0.01 mol/L sodium hydroxide TS (1 in 200,000) add 1 mL of the internal standard solution. Proceed with 20 μ L of this solution under the above operating conditions, and calculate the resolution. Use a column giving elution of levothyroxine and the internal standard in this order with the resolution between these peaks being not less than 2.0.

Dissolution Being specified separately when the drug is granted approval based on the Law.

Assay Weigh accurately and powder not less than 20 Levothyroxine Sodium Tablets. Weigh accurately a portion of the powder, equivalent to about 3 mg of levothyroxine sodium ($C_{15}H_{10}I_4NNaO_4$), into a crucible, and add potassium carbonate amounting to twice the mass of the powder. In the case that the weighed powder is less than 4 g, add 8 g of potassium carbonate to the crucible. Mix well, and gently tap the crucible on the bench to compact the mixture. Overlay with 10 g of potassium carbonate, and compact again by tapping. Heat the crucible strongly at a temperature between 675°C and 700°C for 25 minutes. Cool, add 30 mL of water, heat gently to boiling, and filter into a flask. To the residue add 30 mL of water, boil, and filter into the same flask. Rinse the crucible and the char on the funnel with hot water until the filtrate measures 300 mL. Add slowly 7 mL of freshly prepared bromine TS and diluted phosphoric acid (1 in 2) in the ratio of 3.5 mL to 1 g of the added potassium carbonate, and boil until starch-potassium iodide paper is no longer colored blue by the evolved gas. Wash the inside of the flask with water, and continue boiling for 5 minutes. During the boiling add water from time to time to maintain a volume of not less than 250 mL. Cool, add 5 mL of a solution of phenol (1 in 20), again rinse the inside of the flask with water, and allow to stand for 5 minutes. Add 2 mL of diluted phosphoric acid (1 in 2) and 5 mL of potassium iodide TS, and titrate <2.50> immediately the liberated iodine with 0.01 mol/L sodium thiosulfate VS (indicator: 3 mL of starch TS). Perform a blank determination in the same manner, and make any necessary correction.

Each mL of 0.01 mol/L sodium thiosulfate VS
= 0.3329 mg of $C_{15}H_{10}I_4NNaO_4$

Containers and storage Containers—Tight containers.

Storage—Light-resistant.

Lidocaine

リドカイン

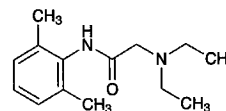

$C_{14}H_{22}N_2O$: 234.34

2-Diethylamino-*N*-(2,6-dimethylphenyl)acetamide
[137-58-6]

Lidocaine, when dried, contains not less than 99.0% of lidocaine ($C_{14}H_{22}N_2O$).

Description Lidocaine occurs as white to pale yellow, crystals or crystalline powder.

It is very soluble in methanol and in ethanol (95), soluble in acetic acid (100) and in diethyl ether, and practically insoluble in water.

It dissolves in dilute hydrochloric acid.

Identification (1) Dissolve 40 mg of Lidocaine in 10 mL of 1 mol/L hydrochloric acid TS, and add water to make 100 mL. Determine the absorption spectrum of the solution as directed under Ultraviolet-visible Spectrophotometry <2.24>, and compare the spectrum with the Reference Spectrum: both spectra exhibit similar intensities of absorption at the same wavelengths.

(2) Determine the infrared absorption spectrum of Lidocaine as directed in the potassium bromide disk method under Infrared Spectrophotometry <2.25>, and compare the spectrum with the Reference Spectrum: both spectra exhibit similar intensities of absorption at the same wave numbers.

Melting point <2.60> 66 – 69°C

Purity (1) Clarity and color of solution—Dissolve 1.0 g of Lidocaine in 2 mL of dilute hydrochloric acid, and add water to make 10 mL: the solution is clear and colorless to light yellow.

(2) Chloride <1.03>—Dissolve 0.6 g of Lidocaine in 6 mL of dilute nitric acid, add water to make 50 mL, and perform the test using this solution as the test solution. Prepare the control solution with 0.70 mL of 0.01 mol/L hydrochloric acid VS (not more than 0.041%).

(3) Sulfate <1.14>—Dissolve 0.5 g of Lidocaine in 5 mL of dilute hydrochloric acid, add water to make 50 mL, and perform the test using this solution as the test solution. Prepare the control solution with 1.0 mL of 0.005 mol/L sulfuric acid VS, 5 mL of dilute hydrochloric acid and water to make 50 mL (not more than 0.096%).

(4) Heavy metals <1.07>—Carbonize 2.0 g of Lidocaine by gentle ignition. After cooling, add 10 mL of a solution of magnesium nitrate hexahydrate in ethanol (95) (1 in 10), and fire the ethanol to burn. After cooling, add 1 mL of sulfuric acid, proceed according to Method 4, and perform the test. Prepare the control solution with 2.0 mL of Standard Lead Solution (not more than 10 ppm).

(5) Related substances—Dissolve 0.10 g of Lidocaine in 2 mL of methanol, and use this solution as the sample solution. Pipet 1 mL of the sample solution, add methanol to make exactly 100 mL, and use this solution as the standard solution. Perform the test with these solutions as directed under Thin-layer Chromatography <2.03>. Spot 10 μ L each of the sample solution and standard solution on a plate of silica gel with fluorescent indicator for thin-layer chromatog-

raphy. Develop the plate with a mixture of ethyl acetate, 2-butanone, water and formic acid (5:3:1:1) to a distance of about 10 cm, air-dry the plate, and dry more at 80°C for 30 minutes. After cooling, examine under ultraviolet light (main wavelength: 254 nm): the spots other than the principal spot obtained from the sample solution are not more intense than the spot from the standard solution.

Loss on drying <2.41> Not more than 0.5% (1 g, in vacuum, silica gel, 24 hours).

Residue on ignition <2.44> Not more than 0.1% (1 g).

Assay Dissolve about 0.5 g of Lidocaine, previously dried and accurately weighed, in 20 mL of acetic acid (100), and titrate <2.50> with 0.1 mol/L perchloric acid VS (indicator: 1 drop of crystal violet TS) until the color of the solution changes from purple to blue-green through blue. Perform a blank determination in the same manner, and make any necessary correction.

Each mL of 0.1 mol/L perchloric acid VS
= 23.43 mg of C₁₄H₂₂N₂O

Containers and storage Containers—Tight containers.

Lidocaine Injection

リドカイン注射液

Lidocaine Injection is an aqueous injection.

It contains not less than 95.0% and not more than 105.0% of the labeled amount of lidocaine hydrochloride (C₁₄H₂₂N₂O.HCl: 270.80).

Method of preparation Prepare as directed under Injections, with Lidocaine and an equivalent amount of Hydrochloric Acid.

No preservative is added in the case of intravenous injections.

Description Lidocaine Injection is a colorless, clear liquid.
pH: 5.0 – 7.0

Identification To a volume of Lidocaine Injection, equivalent to 20 mg of lidocaine hydrochloride (C₁₄H₂₂N₂O.HCl), add 1 mL of sodium hydroxide TS, and extract with 20 mL of hexane. To 10 mL of the hexane extract add 20 mL of 1 mol/L hydrochloric acid TS, and shake vigorously. Determine the absorption spectrum of the water layer as directed under Ultraviolet-visible Spectrophotometry <2.24>: it exhibits a maximum between 261 nm and 265 nm.

Bacterial endotoxins <4.01> Less than 1.0 EU/mg.

Extractable volume <6.05> It meets the requirement.

Foreign insoluble matter <6.06> Perform the test according to Method 1: it meets the requirement.

Insoluble particulate matter <6.07> It meets the requirement.

Sterility <4.06> Perform the test according to the Membrane filtration method: it meets the requirement.

Assay To an exactly measured volume of Lidocaine Injection, equivalent to about 0.1 g of lidocaine hydrochloride (C₁₄H₂₂N₂O.HCl), add exactly 10 mL of the internal standard solution and 0.001 mol/L hydrochloric acid TS to make 50 mL, and use this solution as the sample solution. Separately, weigh accurately about 85 mg of lidocaine for assay,

previously dried in a desiccator (in vacuum, silica gel) for 24 hours, dissolve in 0.5 mL of 1 mol/L hydrochloric acid TS and a suitable volume of 0.001 mol/L hydrochloric acid TS, and add exactly 10 mL of the internal standard solution, then add 0.001 mol/L hydrochloric acid TS to make 50 mL, and use this solution as the standard solution. Perform the test with 5 μL each of the sample solution and standard solution as directed under Liquid Chromatography <2.01> according to the following conditions, and calculate the ratios, Q_T and Q_S, of the peak area of lidocaine to that of the internal standard.

Amount (mg) of lidocaine hydrochloride
(C₁₄H₂₂N₂O.HCl)
= M_S × Q_T/Q_S × 1.156

M_S: Amount (mg) of lidocaine for assay taken

Internal standard solution—A solution of benzophenone in methanol (1 in 4000).

Operating conditions—

Detector: An ultraviolet absorption photometer (wavelength: 254 nm).

Column: A stainless steel column 4 mm in inside diameter and 15 cm in length, packed with octadecylsilanized silica gel for liquid chromatography (10 μm in particle diameter).

Column temperature: A constant temperature of about 25°C.

Mobile phase: Dissolve 2.88 g of sodium lauryl sulfate in 1000 mL of a mixture of 0.02 mol/L phosphate buffer solution (pH 3.0) and acetonitrile (11:9).

Flow rate: Adjust so that the retention time of lidocaine is about 6 minutes.

System suitability—

System performance: When proceed with 5 μL of the standard solution under the above operating conditions, lidocaine and the internal standard are eluted in this order with the resolution between these peaks being not less than 6.

System repeatability: When the test is repeated 6 times with 5 μL of the standard solution under the above operating conditions, the relative standard deviation of the ratios of the peak area of lidocaine to that of the internal standard is not more than 1.0%.

Containers and storage Containers—Hermetic containers.

Limaprost Alfadex

リマプロスト アルファデクス

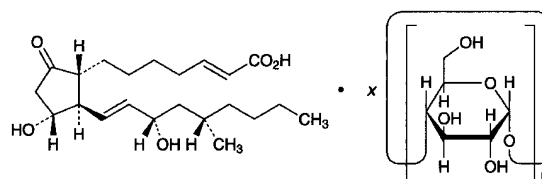

C₂₂H₃₆O₅ · xC₃₆H₆₀O₃₀
(2E)-7-[(1R,2R,3R)-3-Hydroxy-2-[(1E,3S,5S)-3-hydroxy-5-methylnon-1-en-1-yl]-5-oxocyclopentyl]hept-2-enoic acid-α-cyclodextrin
[100459-01-6, limaprost:alfadex = 1:1; clathrate compound]

Limaprost Alfadex is a α-cyclodextrin clathrate compound of limaprost.

It contains not less than 2.8% and not more than 3.2% of limaprost (C₂₂H₃₆O₅: 380.52), calculated on the anhydrous basis.

Description Limaprost Alfadex occurs as a white powder.

It is freely soluble in water, slightly soluble in methanol, very slightly soluble in ethanol (99.5), and practically insoluble in ethyl acetate.

It is hygroscopic.

Identification (1) Dissolve 20 mg of Limaprost Alfadex in 5 mL of water, add 5 mL of ethyl acetate, shake, centrifuge, and use the upper layer as the sample solution (1). Separately, to 20 mg of Limaprost Alfadex add 5 mL of ethyl acetate, shake, centrifuge, and use the supernatant liquid as the sample solution (2). Evaporate the solvent of the sample solutions (1) and (2) under reduced pressure, add 2 mL of sulfuric acid to each of the residue, and shake them for 5 minutes: the solution obtained from the sample solution (1) develops an orange-yellow color while the solution obtained from the sample solution (2) does not develop any color.

(2) Dissolve 20 mg of Limaprost Alfadex in 5 mL of water, add 5 mL of ethyl acetate, shake, centrifuge, and evaporate the solvent of the upper layer under reduced pressure. Dissolve the residue in 2 mL of ethanol (95), 5 mL of 1,3-dinitrobenzene TS, add 5 mL of a solution of potassium hydroxide in ethanol (95) (17 in 100) while ice-cooling, and allow to stand in a dark place while ice-cooling for 20 minutes: a purple color develops.

(3) To 50 mg of Limaprost Alfadex add 1 mL of iodine TS, dissolve by heating in a water bath, and allow to stand: a dark blue precipitate is formed.

(4) Determine the absorption spectrum of a solution of Limaprost Alfadex in dilute ethanol (3 in 10,000) as directed under Ultraviolet-visible Spectrophotometry <2.24>: it does not exhibit a maximum between 200 nm and 400 nm. To 10 mL of this solution add 1 mL of potassium hydroxide-ethanol TS, and allow to stand for 15 minutes. Determine the absorption spectrum of this solution as directed under Ultraviolet-visible Spectrophotometry <2.24>, and compare the spectrum with the Reference Spectrum: both spectra exhibit similar intensities of absorption at the same wavelengths.

Optical rotation <2.49> $[\alpha]_D^{20}$: +125 – 135° (0.1 g calculated on the anhydrous basis, dilute ethanol, 20 mL, 100 mm).

Purity Related substances—Perform the test immediately after preparation of the sample solution. Dissolve 0.10 g of Limaprost Alfadex in 2 mL of water, add 1 mL of ethanol (95), and use this solution as the sample solution. Pipet 1 mL of the sample solution, add dilute ethanol to make exactly 100 mL, and use this solution as the standard solution (1). Pipet 3 mL of the standard solution (1), add dilute ethanol to make exactly 10 mL, and use this solution as the standard solution (2). Perform the test with exactly 3 μ L each of the sample solution and standard solutions (1) and (2) as directed under Liquid Chromatography <2.01> according to the following conditions, and determine each peak area by the automatic integration method: the area of the peak of 17-epi-isomer, having the relative retention time of about 1.1 to limaprost, and the area of the peak of 11-deoxy substance, having the relative retention time of about 2.1, obtained from the sample solution are not larger than the peak area of limaprost from the standard solution (2), and the area of the peak other than the principal peak and the peaks mentioned above from the sample solution is not larger than 1/3 times the peak area of limaprost from the standard solution (2). The total area of the peaks other than limaprost from the samples solution is not larger than the peak area of limaprost from the standard solution (1).

Operating conditions—

Detector, column, column temperature, mobile phase and flow rate: Proceed as directed in the operating conditions in the Assay.

Time span of measurement: About 3 times as long as the retention time of limaprost beginning after the solvent peak.

System suitability—

System performance: Proceed as directed in the system suitability in the Assay.

Test for required detectability: To exactly 1 mL of the standard solution (1) add dilute ethanol to make exactly 10 mL. Confirm that the peak area of limaprost obtained with 3 μ L of this solution is equivalent to 8 to 12% of that with 3 μ L of the standard solution (1).

System repeatability: When the test is repeated 6 times with 3 μ L of the standard solution (1) under the above conditions, the relative standard deviation of the peak area of limaprost is not more than 2.0%.

Water <2.48> Not more than 6.0% (0.2 g, volumetric titration, direct titration).

Assay Weigh accurately about 0.1 g of Limaprost Alfadex, dissolve in 5 mL of water, add exactly 5 mL of the internal standard solution, and use this solution as the sample solution. Separately, weigh accurately about 3 mg of Limaprost RS, dissolve in exactly 5 mL of the internal standard solution, add 5 mL of water, and use this solution as the standard solution. Perform the test with 3 μ L each of the sample solution and the standard solution as directed under Liquid Chromatography <2.01> according to the following conditions, and calculate the ratios, Q_T and Q_S , of the peak area of limaprost to that of the internal standard.

$$\text{Amount (mg) of limaprost (C}_{22}\text{H}_{36}\text{O}_5) = M_S \times Q_T/Q_S$$

M_S : Amount (mg) of Limaprost RS taken

Internal standard solution—A solution of propyl parahydroxybenzoate in ethanol (95) (1 in 4000).

Operating conditions—

Detector: An ultraviolet absorption photometer (wavelength: 215 nm).

Column: A stainless steel column 4.6 mm in inside diameter and 15 cm in length, packed with octadecylsilanized silica gel for liquid chromatography (5 μ m in particle diameter).

Column temperature: A constant temperature of about 25°C.

Mobile phase: A mixture of 0.02 mol/L potassium dihydrogen phosphate TS, acetonitrile for liquid chromatography and 2-propanol for liquid chromatography (9:5:2).

Flow rate: Adjust so that the retention time of limaprost is about 12 minutes.

System suitability—

System performance: When the procedure is run with 3 μ L of the standard solution under the above operating conditions, the internal standard and limaprost are eluted in this order with the resolution between these peaks being not less than 7.

System repeatability: When the test is repeated 6 times with 3 μ L of the standard solution under the above operating conditions, the relative standard deviation of the ratios of the peak area of limaprost to that of the internal standard is not more than 1.0%.

Containers and storage Containers—Tight containers.

Storage—Light-resistant, at a temperature not exceeding –10°C.

Lincomycin Hydrochloride Hydrate

リンコマイシン塩酸塩水和物

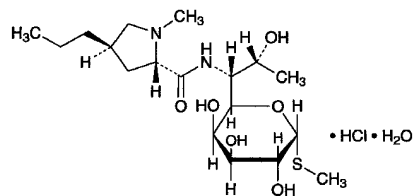

$C_{18}H_{34}N_2O_6S \cdot HCl \cdot H_2O$: 461.01

Methyl 6,8-dideoxy-6-[(2*S*,4*R*)-1-methyl-4-propylpyrrolidine-2-carboxamido]-1-thio-D-erythro- α -D-galacto-octopyranoside monohydrochloride monohydrate [7179-49-9]

Lincomycin Hydrochloride Hydrate is the hydrochloride of a substance having antibacterial activity produced by the growth of *Streptomyces lincolnensis* var. *lincolnensis*.

It contains not less than 850 μ g (potency) and not more than 930 μ g (potency) per mg, calculated on the anhydrous basis. The potency of Lincomycin Hydrochloride Hydrate is expressed as mass (potency) of lincomycin ($C_{18}H_{34}N_2O_6S$: 406.54).

Description Lincomycin Hydrochloride Hydrate occurs as white, crystals or crystalline powder.

It is freely soluble in water and in methanol, sparingly soluble in ethanol (95).

Identification (1) Determine the infrared absorption spectrum of Lincomycin Hydrochloride Hydrate as directed in the paste method under Infrared Spectrophotometry <2.25>, and compare the spectrum with the Reference Spectrum or the spectrum of Lincomycin Hydrochloride RS: both spectra exhibit similar intensities of absorption at the same wave numbers.

(2) A solution of Lincomycin Hydrochloride Hydrate (1 in 100) responds to Qualitative Tests <1.09> (2) for chloride.

Optical rotation <2.49> $[\alpha]_D^{20}$: +135 – +150° (0.5 g, water, 25 mL, 100 mm).

pH <2.54> Dissolve 0.10 g of Lincomycin Hydrochloride Hydrate in 1 mL of water: 3.0 – 5.5.

Purity (1) Clarity and color of solution—Dissolve 1.0 g of Lincomycin Hydrochloride Hydrate in 10 mL of water: the solution is clear and colorless.

(2) Heavy metals <1.07>—Proceed with 2.0 g of Lincomycin Hydrochloride Hydrate according to Method 4, and perform the test. Prepare the control solution with 1.0 mL of Standard Lead Solution (not more than 5 ppm).

(3) Lincomycin B—Use the sample solution obtained in the Assay as the sample solution. Perform the test with 20 μ L of the sample solution as directed under Liquid Chromatography <2.01> according to the following conditions, and determine the peak areas of lincomycin and lincomycin B, having the relative retention time of about 0.5 to lincomycin obtained from the sample solution, by the automatic integration method: the peak area of lincomycin B is not more than 2.0% of the sum of the peak areas of lincomycin and lincomycin B.

Operating conditions—

Proceed as directed in the operating conditions in the

Assay.

System suitability—

System performance, and system repeatability: Proceed as directed in the system suitability in the Assay.

Test for required detectability: Measure exactly 1 mL of the sample solution, and add the mobile phase to make exactly 50 mL. Confirm that the peak area of lincomycin obtained from 20 μ L of this solution is equivalent to 1.4 to 2.6% of that obtained from 20 μ L of the sample solution.

Water <2.48> 3.0 – 6.0% (0.5 g, volumetric titration, direct titration).

Assay Weigh accurately an amount of Lincomycin Hydrochloride Hydrate and Lincomycin Hydrochloride RS, equivalent to about 10 mg (potency), dissolve each in the mobile phase to make exactly 10 mL, and use these solutions as the sample solution and standard solution. Perform the test with exactly 20 μ L each of the sample solution and standard solution as directed under Liquid Chromatography <2.01> according to the following conditions, and determine the peak areas, A_T and A_S , of lincomycin in each solution.

$$\text{Amount } [\mu\text{g (potency)}] \text{ of lincomycin } (C_{18}H_{34}N_2O_6S) \\ = M_S \times A_T/A_S \times 1000$$

M_S : Amount [mg (potency)] of Lincomycin Hydrochloride RS taken

Operating conditions—

Detector: An ultraviolet absorption photometer (wavelength: 210 nm).

Column: A stainless steel column 4 mm in inside diameter and 25 cm in length, packed with octylsilylated silica gel for liquid chromatography (5 μ m in particle diameter).

Column temperature: A constant temperature of about 46°C.

Mobile phase: To 13.5 mL phosphoric acid add 1000 mL of water, and adjust the pH to 6.0 with ammonia TS. To 780 mL of this solution add 150 mL of acetonitrile and 150 mL of methanol.

Flow rate: Adjust so that the retention time of lincomycin is about 9 minutes.

System suitability—

System performance: When the procedure is run with 20 μ L of the standard solution under the above operating conditions, the number of theoretical plates and the symmetry factor of the peak of lincomycin are not less than 4000 and not more than 1.3, respectively.

System repeatability: When the test is repeated 6 times with 20 μ L of the standard solution under the above operating conditions, the relative standard deviation of the peak area of lincomycin is not more than 2.0%.

Containers and storage Containers—Tight containers.

Lincomycin Hydrochloride Injection

リンコマイシン塩酸塩注射液

Lincomycin Hydrochloride Injection is an aqueous injection.

It contains not less than 93.0% and not more than 107.0% of the labeled potency of lincomycin ($C_{18}H_{34}N_2O_6S$: 406.54).

Method of preparation Prepare as directed under Injections, with Lincomycin Hydrochloride Hydrate.

Description Lincomycin Hydrochloride Injection is a clear, colorless liquid.

Identification To a volume of Lincomycin Hydrochloride Injection, equivalent to 30 mg (potency) of Lincomycin Hydrochloride Hydrate, add 30 mL of water, and use this solution as the sample solution. Separately, dissolve 10 mg (potency) of Lincomycin Hydrochloride RS in 10 mL of water, and use this solution as the standard solution. Perform the test with these solutions as directed under Thin-layer Chromatography <2.03>. Spot 5 μ L each of the sample solution and standard solution on a plate of silica gel for thin-layer chromatography. Dissolve 150 g of ammonium acetate in 800 mL of water, adjust the pH to 9.6 with ammonia solution (28), and add water to make 1000 mL. To 80 mL of this solution add 40 mL of 2-propanol and 90 mL of ethyl acetate, shake, develop the plate with the upper layer of this solution to a distance of about 15 cm, and air-dry the plate. Spray evenly a solution of potassium permanganate (1 in 1000) on the plate: the principal spot obtained from the sample solution and the spot from the standard solution show the same *R_f* value.

pH <2.54> 3.5 – 5.5

Bacterial endotoxins <4.01> Less than 0.50 EU/mg (potency).

Extractable volume <6.05> It meets the requirement.

Foreign insoluble matter <6.06> Perform the test according to Method 1: it meets the requirement.

Insoluble particulate matter <6.07> It meets the requirement.

Sterility <4.06> Perform the test according to the Membrane filtration method: it meets the requirement.

Assay Pipet a volume of Lincomycin Hydrochloride Injection, equivalent to about 0.3 g (potency) of Lincomycin Hydrochloride Hydrate, add the mobile phase to make exactly 30 mL. Pipet 2 mL of this solution, add the mobile phase to make exactly 20 mL, and use this solution as the sample solution. Separately, weigh accurately an amount of Lincomycin Hydrochloride RS, equivalent to 20 mg (potency), dissolve in the mobile phase to make exactly 20 mL, and use this solution as the standard solution. Then, proceed as directed in the Assay under Lincomycin Hydrochloride Hydrate.

$$\begin{aligned} \text{Amount [mg (potency)] of lincomycin } (C_{18}H_{34}N_2O_6S) \\ = M_S \times A_T/A_S \times 15 \end{aligned}$$

M_S : Amount [mg (potency)] of Lincomycin Hydrochloride RS taken

Containers and storage Containers—Hermetic containers.

Liothyronine Sodium

リオチロニンナトリウム

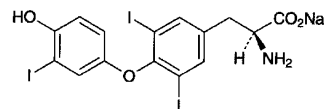

$C_{15}H_{11}I_3NNaO_4$: 672.96

Monosodium *O*-(4-hydroxy-3-iodophenyl)-3,5-diiodo-*L*-tyrosinate
[55-06-1]

Liothyronine Sodium contains not less than 95.0% of liothyronine sodium ($C_{15}H_{11}I_3NNaO_4$), calculated on the dried basis.

Description Liothyronine Sodium occurs as a white to light brown powder. It is odorless.

It is slightly soluble in ethanol (95), and practically insoluble in water and in diethyl ether.

It dissolves in sodium hydroxide TS and in ammonia TS.

Identification (1) To 5 mL of a solution of Liothyronine Sodium in ethanol (95) (1 in 1000) add 1 mL of ninhydrin TS, and warm in a water bath for 5 minutes: a purple color develops.

(2) Heat 0.02 g of Liothyronine Sodium with a few drops of sulfuric acid over a flame: a purple gas is evolved.

(3) Determine the absorption spectrum of a solution of Liothyronine Sodium in ethanol (95) (1 in 10,000) as directed under Ultraviolet-visible Spectrophotometry <2.24>, and compare the spectrum with the Reference Spectrum: both spectra exhibit similar intensities of absorption at the same wavelengths.

(4) Ignite 0.02 g of Liothyronine Sodium until thoroughly charred. After cooling, add 5 mL of water to the residue, shake, and filter: the filtrate responds to Qualitative Tests <1.09> (1) for sodium salt.

Optical rotation <2.49> $[\alpha]_D^{20}$: +18 – +22° (0.2 g calculated on the dried basis, a mixture of ethanol (95) and 1 mol/L hydrochloric acid TS (4:1), 10 mL, 100 mm).

Purity (1) Soluble halide—To 10 mg of Liothyronine Sodium add 10 mL of water and 1 drop of dilute nitric acid, shake for 5 minutes, and filter. Add water to the filtrate to make 10 mL, and mix with 3 drops of silver nitrate TS: the solution shows no more turbidity than the following control solution.

Control solution: To 0.35 mL of 0.01 mol/L hydrochloric acid VS add 1 drop of dilute nitric acid and water to make 10 mL, and add 3 drops of silver nitrate TS.

(2) Iodine and iodide—Dissolve 0.10 g of Liothyronine Sodium in 10 mL of dilute sodium hydroxide TS and 15 mL of water, add 5 mL of dilute sulfuric acid, and allow to stand for 10 minutes with occasional shaking. Filter the mixture into a Nessler tube, add 10 mL of chloroform and 3 drops of a solution of potassium iodate (1 in 100) to the filtrate, mix for 30 seconds, and allow to stand: the chloroform layer has no more color than the following control solution.

Control solution: Weigh exactly 0.111 g of potassium iodide, and dissolve in water to make 1000 mL. Pipet 1 mL of this solution, add 10 mL of dilute hydroxide TS, 14 mL of water and 5 mL of dilute sulfuric acid, and mix. Filter the mixture into a Nessler tube, and perform the test with the filtrate in the same manner as for the sample.

(3) Related substances—Dissolve 0.15 g of Liothyronine Sodium in 5 mL of diluted ammonia TS (1 in 3), and use this solution as the sample solution. Pipet 1 mL of the sample solution, add diluted ammonia TS (1 in 3) to make exactly 50 mL, and use this solution as the standard solution. Perform the test with these solutions as directed under Thin-layer Chromatography <2.03>. Spot 1 μ L each of the sample solution and standard solution on a plate of silica gel for thin-layer chromatography. Develop the plate with a mixture of *t*-butyl alcohol, *t*-amyl alcohol, water, ammonia solution (28) and 2-butanone (59:32:17:15:7) to a distance of about 12 cm, and air-dry the plate. Spray evenly a solution of 0.3 g of ninhydrin in 100 mL of a mixture of 1-butanol and acetic acid (100) (97:3) on the plate, and dry the plate at 100°C for 3 minutes: the spots other than the principal spot obtained from the sample solution are not more intense than the spot from the standard solution.

Loss on drying <2.41> Not more than 4.0% (0.2 g, 105°C, 2 hours).

Assay Weigh accurately about 25 mg of Liothyronine Sodium, and proceed as directed under Oxygen Flask Combustion Method <1.06>, using a mixture of 10 mL of a solution of sodium hydroxide (1 in 100) and 1 mL of a freshly prepared solution of sodium bisulfate (1 in 100) as the absorbing liquid, and prepare the test solution. Apply a small amount of water to the upper part of apparatus A, pull out C carefully, and wash C, B and the inner wall of A with 40 mL of water. To the test solution add 1 mL of bromine-acetic acid TS, insert the stopper C, and shake vigorously for 1 minute. Remove the stopper, rinse the stopper, the sample holder and the inner wall of the flask with 40 mL of water, and add 0.5 mL of formic acid. Stopper the flask with C, and shake vigorously for 1 minute again. Remove the stopper, and rinse the stopper, the sample holder and the inner wall of the flask with 40 mL of water again. Bubble the solution with enough nitrogen gas in the flask to remove the oxygen and excess bromine, add 0.5 g of potassium iodide to the solution, and dissolve. Add immediately 3 mL of dilute sulfuric acid, mix, and allow to stand for 2 minutes. Titrate <2.50> the solution with 0.02 mol/L sodium thiosulfate VS (indicator: 3 mL of starch TS). Perform a blank determination in the same manner, and make any necessary correction.

Each mL of 0.02 mol/L sodium thiosulfate VS
= 0.7477 mg of $C_{15}H_{11}I_3NNaO_4$

Containers and storage Containers—Tight containers.
Storage—Light-resistant.

Liothyronine Sodium Tablets

リオチロニンナトリウム錠

Liothyronine Sodium Tablets contain not less than 90.0% and not more than 110.0% of the labeled amount of liothyronine sodium ($C_{15}H_{11}I_3NNaO_4$; 672.96).

Method of preparation Prepare as directed under Tablets, with Liothyronine Sodium.

Identification (1) To a glass-stoppered centrifuge tube add a portion of finely powdered Liothyronine Sodium Tablets, equivalent to 0.1 mg of Liothyronine Sodium, add 30 mL of dilute sodium hydroxide TS, shake vigorously, and centrifuge. Transfer the supernatant liquid to a separator,

add 10 mL of dilute hydrochloric acid, and extract with two 20-mL portions of ethyl acetate. Filter each extract successively through absorbent cotton previously overlaid with 8 g of anhydrous sodium sulfate. Evaporate the filtrate on a water bath to dryness with the aid of a current of nitrogen. Dissolve the residue in 0.5 mL of methanol, and use this solution as the sample solution. Separately, dissolve 10 mg of liothyronine sodium for thin-layer chromatography in 50 mL of methanol, and use this solution as the standard solution. Perform the test with these solutions as directed under Thin-layer Chromatography <2.03>. Spot 20 μ L each of the sample solution and standard solution on a plate of silica gel for thin-layer chromatography. Develop the plate with a mixture of *t*-butyl alcohol, *t*-amyl alcohol, water, ammonia solution (28) and 2-butanone (59:32:17:15:7) to a distance of about 12 cm, and air-dry the plate. Spray evenly a solution of 0.3 g of ninhydrin in 100 mL of a mixture of 1-butanol and acetic acid (100) (97:3) on the plate, and dry the plate at 100°C for 3 minutes: the spots obtained from the sample solution and the standard solution show a red-purple color, and has the same *R_f* value.

(2) The colored solution obtained in the Assay is blue in color.

Uniformity of dosage units <6.02> Perform the test according to the following method: it meets the requirement of the Content uniformity test.

Place 1 tablet of Liothyronine Sodium Tablets in a glass-stoppered centrifuge tube, add exactly 10 mL of 0.01 mol/L sodium hydroxide TS, warm at 50°C for 15 minutes, and shake vigorously for 20 minutes. Centrifuge for 5 minutes, and filter the supernatant liquid, if necessary. Pipet a definite volume of this solution, and add a volume of 0.01 mol/L sodium hydroxide TS to prepare a definite volume of a solution containing about 0.5 μ g of liothyronine sodium ($C_{15}H_{11}I_3NNaO_4$) per mL. Pipet 5 mL of this solution, add exactly 1 mL of the internal standard solution, and use this solution as the sample solution. Perform the test with 200 μ L of the sample solution as directed under Liquid Chromatography <2.01> according to the following conditions, and calculate the ratio of the peak area of the liothyronine to that of the internal standard. Calculate the mean value of the ratios of each peak area of 10 samples: the deviation (%) of each ratio of the peak area from the mean value should be not more than 15%. When the deviation (%) is more than 15%, and 1 sample shows not more than 25%, perform another test with 20 samples. Calculate the deviation (%) of each ratio of the peak area from the mean value of the 30 samples used in the two tests: there should be not more than 1 sample with the deviation more than 15% but not more than 25%, and no sample should deviate by more than 25%.

Internal standard solution—A solution of propylparahydroxybenzoate in a mixture of methanol and diluted phosphoric acid (1 in 10) (9:1) (1 in 250,000).

Operating conditions—

Detector: An ultraviolet absorption photometer (wavelength: 225 nm).

Column: A stainless steel column 4.6 mm in inside diameter and 15 cm in length, packed with octadecylsilylated silica gel for liquid chromatography (5 μ m in particle diameter).

Column temperature: A constant temperature of about 25°C.

Mobile phase: Diluted methanol (57 in 100).

Flow rate: Adjust so that the retention time of liothyronine is about 9 minutes.

System suitability—

System performance: To 5 mL of a solution of liothyronine sodium in 0.01 mol/L sodium hydroxide TS (1 in 2,000,000) add 1 mL of the internal standard solution, and use this solution as the solution for system suitability test. When the procedure is run with 200 μ L of this solution under the above operating conditions, the internal standard and liothyronine are eluted in this order with the resolution between these peaks being not less than 2.0.

System repeatability: When the test is repeated 6 times with 200 μ L of the solution for system suitability test under the above operating conditions, the relative standard deviation of the ratios of the peak area of liothyronine to that of the internal standard is not more than 1.0%.

Assay Weigh accurately not less than 20 Lisinopril Sodium Tablets, and finely powder. Place an accurately weighed portion of the powder, equivalent to about 50 μ g of liothyronine sodium ($C_{15}H_{11}I_3NNaO_4$), in an agate mortar, add 1 g of powdered potassium carbonate, and mix well. Transfer the mixture cautiously to a porcelain crucible, and compact the contents by gently tapping the crucible on a table. Add an additional 1.5 g of powdered potassium carbonate to the same agate mortar, mix well with any content adhering to the mortar, cautiously overlay the mixture on the top of the same porcelain crucible, and compact the charge again in the same manner. Ignite the combined mixture in the crucible between 675°C and 700°C for 30 minutes. Cool, add a few mL of water to the crucible, heat gently to boiling, and filter the contents of the crucible through a glass filter (G4) into a 20-mL volumetric flask. Wash the residue with water, and combine the washings with the filtrate. Cool, add water to make 20 mL, and use this solution as the sample solution. Separately, weigh accurately about 75 mg of potassium iodide for assay, previously dried at 105°C for 4 hours, and dissolve in water to make exactly 200 mL. Measure exactly 5 mL of the solution, and add a solution of potassium carbonate (1 in 8) to make exactly 100 mL. To 2 mL of this solution, exactly measured, add a solution of potassium carbonate (1 in 8) to make exactly 20 mL, and use the solution as the standard solution. Pipet 5 mL each of the sample solution and the standard solution into glass-stoppered test tubes, add 3.0 mL of diluted sulfuric acid (4 in 25) and 2.0 mL of potassium permanganate TS, and heat on a water bath for 15 minutes. Cool, add 1.0 mL of diluted sodium nitrite TS (1 in 10), swirl to mix, and add 1.0 mL of a solution of ammonium amidosulfate (1 in 10). Allow to stand at room temperature for 10 minutes with occasional shaking. Then add 1.0 mL of potato starch TS and 1.0 mL of a freshly prepared, diluted potassium iodide TS (1 in 40), swirl to mix, and transfer each solution to a 20-mL volumetric flask. Rinse the test tube with water, collect the washings in the volumetric flask, add water to make 20 mL, and allow to stand for 10 minutes. Perform the test with these solutions as directed under Ultraviolet-visible Spectrophotometry <2.24>, using a solution prepared with 5 mL of potassium carbonate (1 in 8) in the same manner as the sample solution as the blank. Determine the absorbances, A_T and A_S , of the subsequent solutions of the sample solution and the standard solution at the wavelength of maximum absorption at about 600 nm, respectively.

$$\text{Amount (mg) of liothyronine sodium (C}_{15}\text{H}_{11}\text{I}_3\text{NNaO}_4) = M_S \times A_T/A_S \times 1/2000 \times 1.351$$

M_S : Amount (mg) of potassium iodide for assay taken

Containers and storage Containers—Tight containers.
Storage—Light-resistant.

Lisinopril Hydrate

リシノプリル水和物

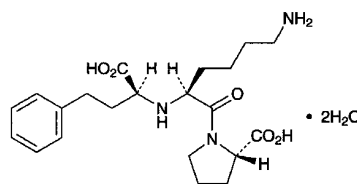

$C_{21}H_{31}N_3O_5 \cdot 2H_2O$: 441.52
(2*S*)-1-[(2*S*)-6-Amino-2-[(1*S*)-1-carboxy-3-phenylpropylamino]hexanoyl]pyrrolidine-2-carboxylic acid dihydrate
[83915-83-7]

Lisinopril Hydrate contains not less than 98.5% and not more than 101.0% of lisinopril ($C_{21}H_{31}N_3O_5$; 405.49), calculated on the anhydrous basis.

Description Lisinopril Hydrate occurs as a white crystalline powder, having a slight characteristic odor.

It is soluble in water, sparingly soluble in methanol, and practically insoluble in ethanol (99.5).

Melting point: about 160°C (with decomposition).

Identification (1) Determine the absorption spectrum of a solution of Lisinopril Hydrate in methanol (1 in 1000) as directed under Ultraviolet-visible Spectrophotometry <2.24>, and compare the spectrum with the Reference Spectrum: both spectra exhibit similar intensities of absorption at the same wavelengths.

(2) Determine the infrared absorption spectrum of Lisinopril Hydrate as directed in the paste method under Infrared Spectrophotometry <2.25>, and compare the spectrum with the Reference Spectrum: both spectra exhibit similar intensities of absorption at the same wave numbers.

Optical rotation <2.49> $[\alpha]_D^{25}$: $-43.0 - -47.0^\circ$ (0.25 g calculated on the anhydrous basis, 0.25 mol/L zinc acetate buffer solution (pH 6.4), 25 mL, 100 mm).

Purity (1) Heavy metals <1.07>—Proceed with 2.0 g of Lisinopril Hydrate according to Method 4, and perform the test. Prepare the control solution with 2.0 mL of Standard Lead Solution (not more than 10 ppm).

(2) Related substances—Dissolve about 0.10 g of Lisinopril Hydrate in 50 mL of water, and use this solution as the sample solution. Pipet 3 mL of the sample solution, add water to make exactly 200 mL, and use this solution as the standard solution. Perform the test with exactly 15 μ L each of the sample solution and standard solution as directed under Liquid Chromatography <2.01> according to the following conditions, and determine each peak area by the automatic integration method: the area of the peak, having the relative retention time of about 1.2 to lisinopril obtained from the sample solution, is not larger than 1/5 times the peak area of lisinopril from the standard solution, the area of the peak other than lisinopril and the peak mentioned above from the sample solution, is not larger than 2/15 times the peak area of lisinopril from the standard solution, and the total area of the peaks other than lisinopril from the sample solution, is not larger than the peak area of lisinopril from the standard solution.

Operating conditions—

Detector: An ultraviolet absorption photometer (wavelength: 215 nm).

Column: A stainless steel column 4.0 mm in inside diameter and 20 cm in length, packed with octadecylsilanized silica gel for liquid chromatography (7 μm in particle diameter).

Column temperature: A constant temperature of about 60°C.

Mobile phase A: Diluted 0.05 mol/L sodium dihydrogen phosphate TS (1 in 2).

Mobile phase B: A mixture of diluted 0.05 mol/L sodium dihydrogen phosphate TS (1 in 2) and acetonitrile for liquid chromatography (3:2).

Flowing of mobile phase: Control the gradient by mixing the mobile phases A and B as directed in the following table.

Time after injection of sample (min)	Mobile phase A (vol%)	Mobile phase B (vol%)
0 - 10	90 → 50	10 → 50
10 - 25	50	50

Flow rate: About 1.5 mL per minute.

Time span of measurement: About 2.5 times as long as the retention time of lisinopril, beginning after the solvent peak.
System suitability—

Test for required detectability: Measure exactly 2.5 mL of the standard solution, and add water to make exactly 50 mL. Confirm that the peak area of lisinopril obtained with 15 μL of this solution is equivalent to 3.5 to 6.5% of that with 15 μL of the standard solution.

System performance: To 10 mg of lisinopril hydrate and 2 mL of a solution of anhydrous caffeine (1 in 1000) add water to make 200 mL. When the procedure is run with 15 μL of this solution under the above operating conditions, lisinopril and caffeine are eluted in this order with the resolution between these peaks being not less than 6.

System repeatability: When the test is repeated 6 times with 15 μL of the standard solution under the above operating conditions, the relative standard deviation of the peak area of lisinopril is not more than 2.0%.

Water <2.48> Not less than 8.0% and not more than 9.5% (0.3 g, volumetric titration, back titration).

Residue on ignition <2.44> Not more than 0.1% (1 g).

Assay Weigh accurately about 0.66 g of Lisinopril Hydrate, dissolve in 80 mL of water, and titrate <2.50> with 0.1 mol/L sodium hydroxide VS (potentiometric titration). Perform a blank determination in the same manner, and make any necessary correction.

Each mL of 0.1 mol/L sodium hydroxide VS
= 40.55 mg of $\text{C}_{21}\text{H}_{31}\text{N}_3\text{O}_5$

Containers and storage Containers—Well-closed containers.

Lisinopril Tablets

リシノプリル錠

Lisinopril Tablets contain not less than 95.0% and not more than 105.0% of the labeled amount of lisinopril ($\text{C}_{21}\text{H}_{31}\text{N}_3\text{O}_5$; 405.49).

Method of preparation Prepare as directed under Tablets, with Lisinopril Hydrate.

Identification To an amount of powdered Lisinopril

Tablets, equivalent to 10 mg of lisinopril ($\text{C}_{21}\text{H}_{31}\text{N}_3\text{O}_5$), add 10 mL of methanol, shake for 20 minutes, filter, and use the filtrate as the sample solution. Separately, dissolve 10 mg of lisinopril in 10 mL of methanol, and use this solution as the standard solution. Perform the test with these solutions as directed under Thin-layer Chromatography <2.03>. Spot 30 μL each of the sample solution and standard solution on a plate of silica gel for thin-layer chromatography. Develop the plate with a mixture of acetonitrile, acetic acid (100), water and ethyl acetate (2:2:1:1) to a distance of about 10 cm, and air-dry the plate. Spray evenly ninhydrin TS on the plate, and heat the plate at 120°C: the principal spot obtained from the sample solution and the spot from the standard solution show a red-purple color and their *R_f* values are the same.

Purity Related substances—Powder not less than 20 Lisinopril Tablets. Take a portion of the powder, equivalent to about 25 mg of lisinopril ($\text{C}_{21}\text{H}_{31}\text{N}_3\text{O}_5$), add 25 mL of water, shake for 20 minutes, filter, and use the filtrate as the sample solution. Pipet 3 mL of the sample solution, add water to make exactly 200 mL, and use this solution as the standard solution. Perform the test with exactly 15 μL each of the sample solution and standard solution as directed under Liquid Chromatography <2.01> according to the following conditions, and determine each peak area by the automatic integration method: the peak area of lisinopril diketopiperazine, having the relative retention time of about 2.0 to lisinopril obtained from the sample solution, is not larger than 2/3 times the peak area of lisinopril from the standard solution.

Operating conditions—

Proceed as directed in the operating conditions in the Purity (2) under Lisinopril Hydrate.

System suitability—

System performance: Proceed as directed in the system suitability in the Purity (2) under Lisinopril Hydrate.

Test for required detectability: To exactly 2.5 mL of the standard solution add water to make exactly 50 mL. Confirm that the peak area of lisinopril obtained with 15 μL of this solution is equivalent to 3.5 to 6.5% of that with 15 μL of the standard solution.

System repeatability: When the test is repeated 6 times with 15 μL of the standard solution under the above operating conditions, the relative standard deviation of the peak area of lisinopril is not more than 2.0%.

Uniformity of dosage units <6.02> Perform the test according to the following method: it meets the requirement of the Content uniformity test.

To 1 tablet of Lisinopril Tablets add exactly 5 mL of the internal standard solution per 1 mg of lisinopril ($\text{C}_{21}\text{H}_{31}\text{N}_3\text{O}_5$), shake for 20 minutes, centrifuge, and use the supernatant liquid as the sample solution. Hereafter, proceed as directed in the Assay.

Amount (mg) of lisinopril ($\text{C}_{21}\text{H}_{31}\text{N}_3\text{O}_5$)
= $M_S \times Q_T / Q_S \times C / 10$

M_S : Amount (mg) of lisinopril for assay taken, calculated on the anhydrous basis

C : Labeled amount (mg) of lisinopril ($\text{C}_{21}\text{H}_{31}\text{N}_3\text{O}_5$) in 1 tablet

Internal standard solution—A solution of anhydrous caffeine (1 in 20,000).

Dissolution <6.10> When the test is performed at 50 revolutions per minute according to the Paddle method, using 900 mL of water as the dissolution medium, the dissolution rate

of a 5-mg tablet in 60 minutes and that of a 10-mg tablet in 90 minutes is not less than 80%, and that of a 20-mg tablet in 90 minutes is not less than 75%.

Start the test with 1 tablet of Lisinopril Tablets, withdraw not less than 20 mL of the medium at the specified minute after starting the test, and filter through a membrane filter with a pore size not exceeding 0.5 μm . Discard not less than 10 mL of the first filtrate, pipet V mL of the subsequent filtrate, add water to make exactly V' mL so that each mL contains about 5.6 μg of lisinopril ($\text{C}_{21}\text{H}_{31}\text{N}_3\text{O}_5$), and use this solution as the sample solution. Separately, weigh accurately about 15 mg of lisinopril for assay (separately determined the water <2.48> in the same manner as Lisinopril Hydrate), and dissolve in water to make exactly 100 mL. Pipet 2 mL of this solution, add water to make exactly 50 mL, and use this solution as the standard solution. Perform the test with exactly 50 μL each of the sample solution and standard solution as directed under Liquid Chromatography <2.01> according to the following conditions, and determine the peak areas, A_T and A_S , of lisinopril in each solution.

Dissolution rate (%) with respect to the labeled amount of lisinopril ($\text{C}_{21}\text{H}_{31}\text{N}_3\text{O}_5$)

$$= M_S \times A_T/A_S \times V'/V \times 1/C \times 36$$

M_S : Amount (mg) of lisinopril for assay taken, calculated on the anhydrous basis

C : Labeled amount (mg) of lisinopril ($\text{C}_{21}\text{H}_{31}\text{N}_3\text{O}_5$) in 1 tablet

Operating conditions—

Detector, column temperature, and mobile phase: Proceed as directed in the operating conditions in the Assay.

Column: A stainless steel column 4.6 mm in inside diameter and 15 cm in length, packed with octadecylsilanized silica gel for liquid chromatography (5 μm in particle diameter).

Flow rate: Adjust so that the retention time of lisinopril is about 7 minutes.

System suitability—

System performance: When the procedure is run with 50 μL of the standard solution under the above operating conditions, the number of theoretical plates and the symmetry factor of the peak of lisinopril are not less than 1000 and not more than 1.5, respectively.

System repeatability: When the test is repeated 6 times with 50 μL of the standard solution under the above operating conditions, the relative standard deviation of the peak area of lisinopril is not more than 2.0%.

Assay Weigh accurately the mass of not less than 20 Lisinopril Tablets, and powder. Weigh accurately a portion of the powder, equivalent to about 5 mg of lisinopril ($\text{C}_{21}\text{H}_{31}\text{N}_3\text{O}_5$), add exactly 25 mL of the internal standard solution, shake for 20 minutes, centrifuge, and use the supernatant liquid as the sample solution. Separately, weigh accurately about 10 mg of lisinopril for assay (separately determined the water <2.48> in the same manner as Lisinopril Hydrate), add exactly 50 mL of the internal standard solution to dissolve, and use this solution as the standard solution. Perform the test with 10 μL each of the sample solution and standard solution as directed under Liquid Chromatography <2.01> according to the following conditions, and calculate the ratios, Q_T and Q_S , of the peak area of lisinopril to that of the internal standard.

Amount (mg) of lisinopril ($\text{C}_{21}\text{H}_{31}\text{N}_3\text{O}_5$)

$$= M_S \times Q_T/Q_S \times 1/2$$

M_S : Amount (mg) of lisinopril for assay taken, calculated on the anhydrous basis

Internal standard solution—A solution of anhydrous caffeine (1 in 20,000).

Operating conditions—

Detector: An ultraviolet absorption photometer (wavelength: 215 nm).

Column: A stainless steel column 4.0 mm in inside diameter and 20 cm in length, packed with octadecylsilanized silica gel for liquid chromatography (7 μm in particle diameter).

Column temperature: A constant temperature of about 60°C.

Mobile phase: A mixture of diluted 0.05 mol/L sodium dihydrogen phosphate TS (1 in 2) and acetonitrile for liquid chromatography (19:1).

Flow rate: Adjust so that the retention time of lisinopril is about 6 minutes.

System suitability—

System performance: When the procedure is run with 10 μL of the standard solution under the above operating conditions, lisinopril and the internal standard are eluted in this order with the resolution between these peaks being not less than 7.

System repeatability: When the test is repeated 6 times with 10 μL of the standard solution under the above operating conditions, the relative standard deviation of the ratio of the peak area of lisinopril to that of the internal standard is not more than 1.0%.

Containers and storage Containers—Well-closed containers.

Lithium Carbonate

炭酸リチウム

Li_2CO_3 : 73.89

Lithium Carbonate, when dried, contains not less than 99.5% of lithium carbonate (Li_2CO_3).

Description Lithium Carbonate occurs as a white crystalline powder. It is odorless.

It is sparingly soluble in water, slightly soluble in hot water, and practically insoluble in ethanol (95) and in diethyl ether.

It dissolves in dilute acetic acid.

The pH of a solution dissolved 1.0 g of Lithium Carbonate in 100 mL of water is between 10.9 and 11.5.

Identification (1) Perform the test as directed under Flame Coloration Test <1.04> (1) with Lithium Carbonate: a persistent red color appears.

(2) Dissolve 0.2 g of Lithium Carbonate in 3 mL of dilute hydrochloric acid, and add 4 mL of sodium hydroxide TS and 2 mL of disodium hydrogen phosphate TS: a white precipitate is produced. To the precipitate add 2 mL of dilute hydrochloric acid: it dissolves.

(3) A solution of Lithium Carbonate (1 in 100) responds to Qualitative Tests <1.09> for carbonate.

Purity (1) Clarity and color of solution—Dissolve 0.10 g of Lithium Carbonate in 10 mL of water by warming: the solution is clear and colorless.

(2) Acetic acid-insoluble substances—Take 1.0 g of Lithium Carbonate, dissolve in 40 mL of dilute acetic acid, filter the insoluble substances using filter paper for quantitative analysis, wash with five 10-mL portions of water, and ignite the insoluble substances together with the filter paper

to incinerate: the mass of the residue is not more than 1.5 mg.

(3) Chloride <1.03>—To 0.40 g of Lithium Carbonate add 10 mL of water and 7 mL of dilute nitric acid, and dissolve by heating to boil. After cooling, add 6 mL of dilute nitric acid, and dilute with water to make 50 mL. Perform the test using this solution as the test solution. Prepare the control solution with 0.25 mL of 0.01 mol/L hydrochloric acid VS (not more than 0.022%).

(4) Sulfate <1.14>—To 0.40 g of Lithium Carbonate add 10 mL of water and 4 mL of dilute hydrochloric acid, and dissolve by heating to boil. After cooling, add 1 mL of dilute hydrochloric acid, and dilute with water to make 50 mL. Perform the test using this solution as the test solution. Prepare the control solution with 0.40 mL of 0.005 mol/L sulfuric acid VS (not more than 0.048%).

(5) Heavy metals <1.07>—To 4.0 g of Lithium Carbonate add 5 mL of water, gradually add 10 mL of hydrochloric acid while mixing, and dissolve. Evaporate the solution on a water bath to dryness. To the residue add 10 mL of water, and dissolve. Place the solution in a Nessler tube, add 1 drop of phenolphthalein TS, add ammonia TS until the solution shows a slight red color, then add 2 mL of dilute acetic acid, and dilute with water to make 50 mL. Perform the test using this solution as the test solution. Prepare the control solution as follows: Evaporate 10 mL of hydrochloric acid on a water bath to dryness. To the residue add 10 mL of water, and dissolve. Place the solution in a Nessler tube, add 1 drop of phenolphthalein TS, add ammonia TS until the solution shows a pale red color, then add 2.0 mL of Standard Lead Solution and 2 mL of dilute acetic acid, and dilute with water to make 50 mL (not more than 5 ppm).

(6) Iron <1.10>—Prepare the test solution with 1.0 g of Lithium Carbonate according to Method 2 using 11 mL of dilute hydrochloric acid, and perform the test according to Method B. Prepare the control solution with 1.0 mL of Standard Iron Solution (not more than 10 ppm).

(7) Aluminum—To 5.0 g of Lithium Carbonate add 20 mL of water, add gradually 15 mL of hydrochloric acid while stirring, and evaporate to dryness on a water bath. To the residue add 50 mL of water to dissolve, filter if necessary, and assign this solution as solution A. Separately, evaporate 15 mL of hydrochloric acid to dryness on a water bath, then proceed in the same manner, and assign the solution so obtained as solution B. To 10 mL of solution A add 10 mL of water and 5 mL of acetic acid-sodium acetate buffer solution (pH 4.5), and shake. Add 1 mL of a solution of L-ascorbic acid (1 in 100), 2 mL of aluminon TS and water to make 50 mL, shake well, and allow to stand for 10 minutes: the solution has no more color than the following control solution.

Control solution: Dissolve 0.1758 g of aluminum potassium sulfate dodecahydrate in water to make 1000 mL. To 1.0 mL of this solution add 10 mL of solution B and water to make 20 mL, add 5 mL of acetic acid-sodium acetate buffer solution (pH 4.5), and proceed in the same manner.

(8) Barium—To 20 mL of solution A obtained in (7) add 6 mL of water, 0.5 mL of dilute hydrochloric acid, 3 mL of ethanol (95) and 2 mL of potassium sulfate TS, and allow to stand for 1 hour: the solution has no more turbidity than the following control solution.

Control solution: Dissolve 17.8 mg of barium chloride dihydrate in water to make 1000 mL. To 6 mL of this solution add 20 mL of solution B obtained in (7), 0.5 mL of dilute hydrochloric acid and 3 mL of ethanol (95), and proceed in the same manner.

(9) Calcium—Weigh accurately about 5 g of Lithium

Carbonate, add 50 mL of water and 15 mL of hydrochloric acid, and dissolve. Remove carbon dioxide from the solution by boiling, add 5 mL of ammonium oxalate TS, then make alkaline with ammonia TS, and allow to stand for 4 hours. Filter the produced precipitate through a glass filter (G4), wash with warm water until the turbidity of the washing is not produced with calcium chloride TS within 1 minute. Transfer the precipitate and the glass filter into a beaker, add water until the glass filter is covered with water, then add 3 mL of sulfuric acid, heat between 70°C and 80°C, and titrate <2.50> with 0.02 mol/L potassium permanganate VS until a pale red color persists for 30 seconds: the amount of calcium (Ca: 40.08) is not more than 0.05%.

Each mL of 0.02 mol/L potassium permanganate VS = 2.004 mg of Ca

(10) Magnesium—To 3.0 mL of solution A obtained in (7) add 0.2 mL of a solution of titan yellow (1 in 1000) and water to make 20 mL, then add 5 mL of sodium hydroxide (3 in 20), and allow to stand for 10 minutes: the solution has no more color than the following control solution.

Control solution: Dissolve 49.5 mg of magnesium sulfate heptahydrate, previously dried at 105°C for 2 hours and heated at 450°C for 3 hours, in water to make 1000 mL. To 6 mL of this solution add 3 mL of solution B obtained in (7), 0.2 mL of a solution of titanium yellow (1 in 1000) and water to make 20 mL, and proceed in the same manner.

(11) Potassium—Dissolve 1.0 g of Lithium Carbonate in water to make 100 mL, and use this solution as the sample solution. To 5 mL of the sample solution add 1.0 mL of dilute acetic acid, shake, add 5 mL of a solution of sodium tetraphenylborate (1 in 30), shake immediately, and allow to stand for 10 minutes: the solution has no more turbidity than the following control solution.

Control solution: Dissolve 9.5 mg of potassium chloride in water to make 1000 mL. To 5 mL of this solution add 1.0 mL of dilute acetic acid, shake, and proceed in the same manner.

(12) Sodium—Weigh accurately about 0.8 g of Lithium Carbonate, dissolve in water to make exactly 100 mL, and use this solution as the sample stock solution. Measure exactly 25 mL of the sample stock solution, add water to make exactly 100 mL, and use this solution as the sample solution (1). Separately, weigh accurately 25.4 mg of sodium chloride, dissolve in water to make exactly 1000 mL, and use this solution as the standard solution. Measure exactly 25 mL of the sample stock solution, add exactly 20 mL of the standard solution, then add water to make exactly 100 mL, and use this solution as the sample solution (2). Determine emission intensities of sodium using a flame photometer with the sample solution (1) and the sample solution (2) under the following conditions. Adjust the wavelength dial to 589 nm, atomize the sample solution (2) into the flame, then adjust the sensitivity so that the emission intensity L_S shows 100 adjustment, and determine emission intensity L_T of the sample solution (1). Then, make the other conditions identical, change the wavelength dial to 580 nm, determine emission intensity L_B of the sample solution (1): the amount of sodium, calculated from the following equation, is not more than 0.05%.

$$\begin{aligned} \text{Amount (\%)} \text{ of sodium (Na)} \\ = (L_T - L_B) / (L_S - L_T) \times M' / M \times 100 \end{aligned}$$

M : Amount (mg) of the sample in 25 mL of the sample stock solution

M' : Amount (mg) of sodium in 20 mL of the standard solution

(13) Arsenic <1.11>—Prepare the test solution with 1.0 g of Lithium Carbonate, add 2 mL of water and 3 mL of hydrochloric acid, and perform the test (not more than 2 ppm).

Loss on drying <2.41> Not more than 0.5% (1 g, 105°C, 3 hours).

Assay Weigh accurately about 1 g of Lithium Carbonate, previously dried, add exactly 100 mL of water and 50 mL of 0.5 mol/L sulfuric acid VS, remove carbon dioxide by boiling gently, cool, and titrate <2.50> the excess sulfuric acid with 1 mol/L sodium hydroxide VS until the color of the solution changes from red to yellow (indicator: 3 drops of methyl red TS). Perform a blank determination in the same manner.

Each mL of 0.5 mol/L sulfuric acid VS
= 36.95 mg of Li_2CO_3

Containers and storage Containers—Well-closed containers.

Lobenzarit Sodium

ロベンザリットナトリウム

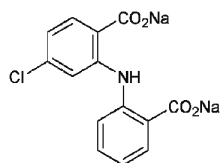

$\text{C}_{14}\text{H}_8\text{ClINNa}_2\text{O}_4$: 335.65

Disodium 2-[(2-carboxylatophenyl)amino]-4-chlorobenzoate
[64808-48-6]

Lobenzarit Sodium, when dried, contains not less than 98.0% and not more than 101.0% of lobenzarit sodium ($\text{C}_{14}\text{H}_8\text{ClINNa}_2\text{O}_4$).

Description Lobenzarit Sodium occurs as a white to pale yellow-white crystalline powder.

It is soluble in water, and practically insoluble in ethanol (99.5).

Identification (1) A solution of Lobenzarit Sodium (1 in 50) responds to Qualitative Tests <1.09> (1) for chloride.

(2) Determine the absorption spectrum of a solution of Lobenzarit Sodium (1 in 100,000) as directed under Ultraviolet-visible Spectrophotometry <2.24>, and compare the spectrum with the Reference Spectrum: both spectra exhibit similar intensities of absorption at the same wavelengths.

(3) Determine the infrared absorption spectrum of Lobenzarit Sodium, previously dried, as directed in the potassium bromide disk method under Infrared Spectrophotometry <2.25>, and compare the spectrum with the Reference Spectrum: both spectra exhibit similar intensities of absorption at the same wave numbers.

(4) A solution of Lobenzarit Sodium (1 in 50) responds to Qualitative Tests <1.09> (2) for sodium salt.

Purity (1) Heavy metals <1.07>—Proceed with 1.0 g of Lobenzarit Sodium according to Method 2, and perform the test. Prepare the control solution with 2.0 mL of Standard Lead Solution (not more than 20 ppm).

(2) Arsenic <1.11>—Prepare the test solution with 2.0 g of Lobenzarit Sodium according to Method 3, and perform the test (not more than 1 ppm).

(3) Related substances—Dissolve 50 mg of Lobenzarit

Sodium in 2.5 mL of water, and use this solution as the sample solution. Pipet 1 mL of the sample solution, and add water to make exactly 100 mL. Pipet 4 mL of this solution, add water to make exactly 20 mL, and use this solution as the standard solution. Perform the test with these solutions as directed under Thin-layer Chromatography <2.03>. Spot 5 μL each of the sample solution and standard solution on a plate of silica gel with fluorescent indicator for thin-layer chromatography. Develop the plate with a mixture of tetrahydrofuran, water and triethylamine (50:15:8) to a distance of about 10 cm, and air-dry the plate. Examine under ultraviolet light (main wavelength: 254 nm): the spot other than the principal spot obtained from the sample solution is not more intense than the spot from the standard solution.

Loss on drying <2.41> Not more than 1.0% (1 g, 105°C, 2 hours).

Assay Weigh accurately about 0.1 g of Lobenzarit Sodium, previously dried, dissolve in exactly 40 mL of water, add exactly 60 mL of a mixture of diethyl ether and tetrahydrofuran (1:1), and titrate <2.50> with 0.1 mol/L hydrochloric acid VS while well shaking (indicator: 10 drops of bromophenol blue TS) until the blue color of the water layer changes to a persistent light blue-green. Perform a blank determination in the same manner, and make any necessary correction.

Each mL of 0.1 mol/L hydrochloric acid VS
= 16.78 mg of $\text{C}_{14}\text{H}_8\text{ClINNa}_2\text{O}_4$

Containers and storage Containers—Tight containers.

Lorazepam

ロラゼパム

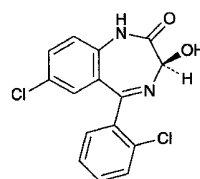

and enantiomer

$\text{C}_{15}\text{H}_{10}\text{Cl}_2\text{N}_2\text{O}_2$: 321.16

(3R)-7-Chloro-5-(2-chlorophenyl)-3-hydroxy-1,3-dihydro-2H-1,4-benzodiazepin-2-one
[846-49-1]

Lorazepam, when dried, contains not less than 98.5% of lorazepam ($\text{C}_{15}\text{H}_{10}\text{Cl}_2\text{N}_2\text{O}_2$).

Description Lorazepam occurs as a white crystalline powder. It is odorless.

It is sparingly soluble in ethanol (95) and in acetone, slightly soluble in diethyl ether, and practically insoluble in water.

It is gradually colored by light.

Identification (1) To 0.02 g of Lorazepam add 15 mL of dilute hydrochloric acid, boil for 5 minutes, and cool: the solution responds to Qualitative Tests <1.09> for primary aromatic amines.

(2) Determine the absorption spectrum of a solution of Lorazepam in ethanol (95) (1 in 200,000) as directed under Ultraviolet-visible Spectrophotometry <2.24>, and compare the spectrum with the Reference Spectrum: both spectra exhibit similar intensities of absorption at the same wavelengths.

(3) Determine the infrared absorption spectrum of

Lorazepam, previously dried, as directed in the potassium bromide disk method under Infrared Spectrophotometry <2.25>, and compare the spectrum with the Reference Spectrum: both spectra exhibit similar intensities of absorption at the same wave numbers.

(4) Perform the test with Lorazepam as directed under Flame Coloration Test <1.04> (2): a green color appears.

Absorbance <2.24> $E_{1\text{cm}}^{1\%}$ (229 nm): 1080 – 1126 (after drying, 1 mg, ethanol (95), 200 mL).

Purity (1) Chloride <1.03>—To 1.0 g of Lorazepam add 50 mL of water, allow to stand for 1 hour with occasional shaking, and filter. To 25 mL of the filtrate add 6 mL of dilute nitric acid and water to make 50 mL. Perform the test using this solution as the test solution. Prepare the control solution with 0.20 mL of 0.01 mol/L hydrochloric acid VS (not more than 0.014%).

(2) Heavy metals <1.07>—Proceed with 1.0 g of Lorazepam according to Method 2, and perform the test. Prepare the control solution with 2.0 mL of Standard Lead Solution (not more than 20 ppm).

(3) Arsenic <1.11>—Prepare the test solution with 1.0 g of Lorazepam according to Method 3, and perform the test (not more than 2 ppm).

(4) Related substances—Dissolve 0.10 g of Lorazepam in 20 mL of ethanol (95), and use this solution as the sample solution. Pipet 1 mL of the sample solution, add ethanol (95) to make exactly 100 mL, and use this solution as the standard solution. Perform the test with these solutions as directed under Thin-layer Chromatography <2.03>. Spot 10 μL each of the sample solution and standard solution on a plate of silica gel with fluorescent indicator for thin-layer chromatography. Develop the plate with a mixture of chloroform, 1,4-dioxane and acetic acid (100) (91:5:4) to a distance of about 15 cm, and air-dry the plate. Examine under ultraviolet light (main wavelength: 254 nm): the spots other than the principal spot obtained from the sample solution are not more intense than the spot from the standard solution.

Loss on drying <2.41> Not more than 0.5% (1 g, in vacuum, 105°C, 3 hours).

Residue on ignition <2.44> Not more than 0.3% (1 g).

Assay Weigh accurately about 0.4 g of Lorazepam, previously dried, dissolve in 50 mL of acetone, and titrate <2.50> with 0.1 mol/L tetrabutylammonium hydroxide VS (potentiometric titration). Perform a blank determination in the same manner, and make any necessary correction.

Each mL of 0.1 mol/L tetrabutylammonium hydroxide VS
= 32.12 mg of $\text{C}_{15}\text{H}_{10}\text{Cl}_2\text{N}_2\text{O}_2$

Containers and storage Containers—Tight containers.
Storage—Light-resistant.

Losartan Potassium

ロサルタンカリウム

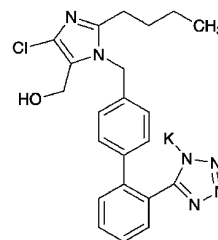

$\text{C}_{22}\text{H}_{22}\text{ClKN}_6\text{O}$: 461.00

Monopotassium 5-[[4'-(2-butyl-4-chloro-5-hydroxymethyl-1H-imidazol-1-yl)methyl]biphenyl-2-yl]-1H-tetrazol-1-ide [124750-99-8]

Losartan Potassium contains not less than 98.5% and not more than 101.0% of losartan potassium ($\text{C}_{22}\text{H}_{22}\text{ClKN}_6\text{O}$), calculated on the anhydrous basis.

Description Losartan Potassium occurs as a white crystalline powder.

It is very soluble in water, and freely soluble in methanol and in ethanol (99.5).

Identification (1) Determine the absorption spectrum of a solution of Losartan Potassium in methanol (1 in 100,000) as directed under Ultraviolet-visible Spectrophotometry <2.24>, and compare the spectrum with the Reference Spectrum or the spectrum of a solution of Losartan Potassium RS prepared in the same manner as the sample solution: both spectra exhibit similar intensities of absorption at the same wavelengths.

(2) Determine the infrared absorption spectrum of Losartan Potassium as directed in the potassium bromide disk method under Infrared Spectrophotometry <2.25>, and compare the spectrum with the Reference Spectrum or the spectrum of Losartan Potassium RS: both spectra exhibit similar intensities of absorption at the same wave numbers.

(3) Losartan Potassium responds to Qualitative Tests <1.09> (1) for potassium salt.

(4) Perform the test with Losartan Potassium as directed under Flame Coloration Test <1.04> (2): a green color appears.

Purity (1) Heavy metals <1.07>—Proceed with 2.0 g of Losartan Potassium according to Method 2, and perform the test. Prepare the control solution with 2.0 mL of Standard Lead Solution (not more than 10 ppm).

(2) Related substances—Dissolve 30 mg of Losartan Potassium in 100 mL of methanol, and use this solution as the sample solution. Pipet 1 mL of this solution, add methanol to make exactly 100 mL, and use this solution as the standard solution. Perform the test with exactly 10 μL each of the sample solution and standard solution as directed under Liquid Chromatography <2.01> according to the following conditions. Determine each peak area of both solutions by the automatic integration method: the area of each peak other than the peaks of solvent and losartan obtained from the sample solution is not larger than 1/10 times the peak area of losartan from the standard solution, and the total area of the peaks other than losartan from the sample solution is not larger than 3/10 times the peak area of losartan from the standard solution.

Operating conditions—

Detector: An ultraviolet absorption photometer (wavelength: 220 nm).

Column: A stainless steel column 4 mm in inside diameter and 25 cm in length, packed with octadecylsilanized silica gel for liquid chromatography (5 μ m in particle diameter).

Column temperature: A constant temperature of about 25°C.

Mobile phase A: Diluted phosphoric acid (1 in 1000).

Mobile phase B: Acetonitrile.

Flowing of mobile phase: Control the gradient by mixing the mobile phases A and B as directed in the following table.

Time after injection of sample (min)	Mobile phase A (vol%)	Mobile phase B (vol%)
0 – 25	75 → 10	25 → 90
25 – 35	10	90

Flow rate: 1.0 mL per minute.

Time span of measurement: For 35 minutes after injection of the sample solution.

System suitability—

Test for required detectability: Pipet 1 mL of the standard solution, and add methanol to make exactly 10 mL. Confirm that the peak area of losartan obtained with 10 μ L of this solution is equivalent to 7 to 13% of that with 10 μ L of the standard solution.

System performance: When the procedure is run with 10 μ L of the standard solution under the above operating conditions, the number of theoretical plates and the symmetry factor of the peak of losartan are not less than 10,000 and not more than 1.3, respectively.

System repeatability: When the test is repeated 6 times with 10 μ L of the standard solution under the above operating conditions, the relative standard deviation of the peak area of losartan is not more than 2.0%.

Water <2.48> Not more than 0.5% (0.25 g, volumetric titration, direct titration).

Assay Weigh accurately about 25 mg each of Losartan Potassium and Losartan Potassium RS (separately, determine the water <2.48> in the same manner as Losartan Potassium), dissolve separately in methanol to make exactly 100 mL, and use these solutions as the sample solution and the standard solution, respectively. Perform the test with exactly 10 μ L each of the sample solution and standard solution as directed under Liquid Chromatography <2.01> according to the following conditions, and determine the peak areas, A_T and A_S , of losartan in each solution.

$$\text{Amount (mg) of losartan potassium (C}_{22}\text{H}_{22}\text{ClKN}_6\text{O)} \\ = M_S \times A_T / A_S$$

M_S : Amount (mg) of Losartan Potassium RS taken, calculated on the anhydrous basis

Operating conditions—

Detector: An ultraviolet absorption photometer (wavelength: 254 nm).

Column: A stainless steel column 4 mm in inside diameter and 25 cm in length, packed with octadecylsilanized silica gel for liquid chromatography (5 μ m in particle diameter).

Column temperature: A constant temperature of about 35°C.

Mobile phase: A mixture of diluted phosphoric acid (1 in 1000) and acetonitrile (3:2).

Flow rate: Adjust so that the retention time of losartan is

about 6 minutes.

System suitability—

System performance: When the procedure is run with 10 μ L of the standard solution under the above operating conditions, the number of theoretical plates and the symmetry factor of the peak of losartan are not less than 5500 and not more than 1.4, respectively.

System repeatability: When the test is repeated 6 times with 10 μ L of the standard solution under the above operating conditions, the relative standard deviation of the peak area of losartan is not more than 1.0%.

Containers and storage Containers—Tight containers.

Losartan Potassium Tablets

ロサルタンカリウム錠

Losartan Potassium Tablets contain not less than 95.0% and not more than 105.0% of the labeled amount of losartan potassium (C₂₂H₂₂ClKN₆O: 461.00).

Method of preparation Prepare as directed under Tablets, with Losartan Potassium.

Identification To an amount of powdered Losartan Potassium Tablets, equivalent to 25 mg of losartan potassium, add 10 mL of methanol, shake well, and centrifuge. To 5 mL of the supernatant liquid add methanol to make 25 mL, and use this solution as the sample solution. Separately, dissolve 25 mg of losartan potassium in 10 mL of methanol. To 5 mL of this solution add methanol to make 25 mL, and use this solution as the standard solution. Perform the test with these solutions as directed under Thin-layer Chromatography <2.03>. Spot 10 μ L each of the sample solution and standard solution on a plate of silica gel with fluorescent indicator for thin-layer chromatography. Develop the plate with a mixture of ethyl acetate, methanol and acetic acid (100) (75:25:1) to a distance of about 10 cm, and air-dry the plate. Examine under ultraviolet light (main wavelength: 254 nm): the principal spot obtained from the sample solution and the spot from the standard solution show the same R_f value.

Uniformity of dosage units <6.02> Perform the Mass variation test, or the Content uniformity test according to the following method: it meets the requirement.

To 1 tablet of Losartan Potassium Tablets add diluted 0.1 mol/L phosphate buffer solution (pH 8.0) (1 in 10) to make exactly 100 mL, and stir until the tablet is completely disintegrated. Pipet 5 mL of this solution, add diluted 0.1 mol/L phosphate buffer solution (pH 8.0) (1 in 10) to make exactly V mL so that each mL contains about 50 μ g of losartan potassium (C₂₂H₂₂ClKN₆O), centrifuge, and use the supernatant liquid as the sample solution. Then, proceed as directed in the Assay.

$$\text{Amount (mg) of losartan potassium (C}_{22}\text{H}_{22}\text{ClKN}_6\text{O)} \\ = M_S \times A_T / A_S \times V / 25$$

M_S : Amount (mg) of Losartan Potassium RS taken, calculated on the anhydrous basis

Dissolution <6.10> When the test is performed at 50 revolutions per minute for 25-mg and 50-mg tablets and at 75 revolutions per minute for 100-mg tablet according to the Paddle method, using 900 mL of water as the dissolution medium, the dissolution rate in 45 minutes of 25-mg and 50-mg tablets, and in 30 minutes of 100-mg tablet are not less than

85%, respectively.

Start the test with 1 tablet of Losartan Potassium Tablets, withdraw not less than 20 mL of the medium at the specified minute after starting the test, and filter through a membrane filter with a pore size not exceeding 0.45 μm . Discard not less than 5 mL of the first filtrate, pipet V mL of the subsequent filtrate, add water to make exactly V' mL so that each mL contains about 22 μg of losartan potassium ($\text{C}_{22}\text{H}_{22}\text{ClKN}_6\text{O}$), and use this solution as the sample solution. Separately, weigh accurately about 50 mg of Losartan Potassium RS (separately determine the water <2.48> in the same manner as Losartan Potassium), and dissolve in water to make exactly 100 mL. Pipet 5 mL of this solution, add water to make exactly 100 mL, and use this solution as the standard solution. Determine the absorbances, A_T and A_S , at 256 nm of the sample solution and standard solution as directed under Ultraviolet-visible Spectrophotometry <2.24>.

Dissolution rate (%) with respect to the labeled amount of losartan potassium ($\text{C}_{22}\text{H}_{22}\text{ClKN}_6\text{O}$)

$$= M_S \times A_T / A_S \times V' / V \times 1 / C \times 45$$

M_S : Amount (mg) of Losartan Potassium RS taken, calculated on the anhydrous basis

C : Labeled amount (mg) of losartan potassium ($\text{C}_{22}\text{H}_{22}\text{ClKN}_6\text{O}$) in 1 tablet

Assay To 20 Losartan Potassium Tablets add diluted 0.1 mol/L phosphate buffer solution (pH 8.0) (1 in 10) to make exactly 1000 mL, and stir until the tablets are completely disintegrated. Pipet 5 mL of this solution, add diluted 0.1 mol/L phosphate buffer solution (pH 8.0) (1 in 10) to make exactly V mL so that each mL contains about 50 μg of losartan potassium ($\text{C}_{22}\text{H}_{22}\text{ClKN}_6\text{O}$), centrifuge, and use the supernatant liquid as the sample solution. Separately, weigh accurately about 25 mg of Losartan Potassium RS (separately determine the water <2.48> in the same manner as Losartan Potassium), dissolve in diluted 0.1 mol/L phosphate buffer solution (pH 8.0) (1 in 10) to make exactly 500 mL, and use this solution as the standard solution. Perform the test with exactly 20 μL each of the sample solution and standard solution as directed under Liquid Chromatography <2.01> according to the following conditions, and determine the peak areas, A_T and A_S , of losartan in each solution.

Amount (mg) of losartan potassium ($\text{C}_{22}\text{H}_{22}\text{ClKN}_6\text{O}$) in 1 tablet

$$= M_S \times A_T / A_S \times V / 50$$

M_S : Amount (mg) of Losartan Potassium RS taken, calculated on the anhydrous basis

Operating conditions—

Detector: An ultraviolet absorption photometer (wavelength: 230 nm).

Column: A stainless steel column 4.6 mm in inside diameter and 25 cm in length, packed with octylsilanized silica gel for liquid chromatography (10 μm in particle diameter).

Column temperature: A constant temperature of about 35°C.

Mobile phase: Dissolve 1.36 g of potassium dihydrogen phosphate in 900 mL of water, adjust to pH 2.5 with phosphoric acid, and add water to make 1000 mL. To 600 mL of this solution add 400 mL of acetonitrile

Flow rate: Adjust so that the retention time of losartan is about 10 minutes.

System suitability—

System performance: When the procedure is run with 20 μL of the standard solution under the above operating conditions, the number of theoretical plates and the symmetry

factor of the peak of losartan are not less than 3000 and not more than 1.5, respectively.

System repeatability: When the test is repeated 6 times with 20 μL of the standard solution under the above operating conditions, the relative standard deviation of the peak area of losartan is not more than 1.0%.

Containers and storage Containers—Tight containers.

Losartan Potassium and Hydrochlorothiazide Tablets

ロスアルタンカリウム・ヒドロクロロチアジド錠

Losartan Potassium and Hydrochlorothiazide Tablets contain not less than 95.0% and not more than 105.0% of the labeled amount of losartan potassium ($\text{C}_{22}\text{H}_{22}\text{ClKN}_6\text{O}$: 461.00) and hydrochlorothiazide ($\text{C}_7\text{H}_8\text{ClN}_3\text{O}_4\text{S}_2$: 297.74).

Method of preparation Prepare as directed under Tablets, with Losartan Potassium and Hydrochlorothiazide.

Identification (1) Shake thoroughly a portion of powdered Losartan Potassium and Hydrochlorothiazide Tablets, equivalent to 50 mg of Losartan Potassium, with 10 mL of methanol, and centrifuge. To 5 mL of the supernatant liquid add methanol to make 50 mL, and use this solution as the sample solution. Separately, dissolve 25 mg of losartan potassium in methanol to make 10 mL. To 5 mL of this solution add methanol to make 25 mL, and use this solution as the standard solution. Perform the test with these solutions as directed under Thin-layer Chromatography <2.03>. Spot 20 μL each of the sample solution and standard solution on a plate of silica gel with fluorescent indicator for thin-layer chromatography. Develop the plate with a mixture of ethyl acetate, methanol and acetic acid (100) (75:25:1) to a distance of about 15 cm, and air-dry the plate. Examine under ultraviolet light (main wavelength: 254 nm): one of the two spots obtained from the sample solution and the spot from the standard solution show the same R_f value.

(2) Shake well a portion of powdered Losartan Potassium and Hydrochlorothiazide Tablets, equivalent to 12.5 mg of Hydrochlorothiazide, with 10 mL of methanol, and centrifuge. To 5 mL of the supernatant liquid add methanol to make 50 mL, and use this solution as the sample solution. Separately, dissolve 25 mg of hydrochlorothiazide in methanol to make 10 mL. To 5 mL of this solution add methanol to make 100 mL, and use this solution as the standard solution. Perform the test with these solutions as directed under Thin-layer Chromatography <2.03>. Spot 20 μL each of the sample solution and standard solution on a plate of silica gel with fluorescent indicator for thin-layer chromatography. Develop the plate with a mixture of ethyl acetate, methanol and acetic acid (100) (75:25:1) to a distance of about 15 cm, and air-dry the plate. Examine under ultraviolet light (main wavelength: 254 nm): one of the two spots obtained from the sample solution and the spot from the standard solution show the same R_f value.

Uniformity of dosage units <6.02>

(1) Losartan potassium—Perform the Mass variation test, or the Content uniformity test according to the following method: it meets the requirement.

To 1 tablet of Losartan Potassium and Hydrochlorothiazide Tablets add $V/2$ mL of a mixture of acetonitrile and sodium dihydrogen phosphate TS (pH 2.5) (3:2), and stir for

60 minutes to disintegrate the tablet, add sodium dihydrogen phosphate TS (pH 2.5) to make exactly V mL so that each mL contains about 0.5 mg of losartan potassium ($C_{22}H_{22}ClKN_6O$). Pipet 10 mL of this solution, add 45 mL of a mixture of acetonitrile and sodium dihydrogen phosphate TS (pH 2.5) (3:2), add sodium dihydrogen phosphate TS (pH 2.5) to make exactly 100 mL, and filter through a membrane filter with a pore size not exceeding $0.45\ \mu\text{m}$. Discard the first 2 mL of the filtrate, and use the subsequent filtrate as the sample solution. Separately, weigh accurately about 46 mg of Losartan Potassium RS (separately determine the water <2.48> in the same manner as Losartan Potassium), and dissolve in 50 mL of a mixture of acetonitrile and sodium dihydrogen phosphate TS (pH 2.5) (3:2), add sodium dihydrogen phosphate TS (pH 2.5) to make exactly 100 mL, and use this solution as the losartan potassium standard stock solution. Pipet 12 mL of the losartan potassium standard stock solution, add 44 mL of a mixture of acetonitrile and sodium dihydrogen phosphate TS (pH 2.5) (3:2), add sodium dihydrogen phosphate TS (pH 2.5) to make exactly 100 mL, and use this solution as the standard solution. Perform the test with exactly $20\ \mu\text{L}$ each of the sample solution and standard solution as directed under Liquid Chromatography <2.01> according to the following conditions, and determine the peak areas, A_T and A_S , of losartan in each solution.

$$\text{Amount (mg) of losartan potassium (C}_{22}\text{H}_{22}\text{ClKN}_6\text{O)} \\ = M_S \times A_T/A_S \times 3V/250$$

M_S : Amount (mg) of Losartan Potassium RS taken, calculated on the anhydrous basis

Operating conditions—

Detector: An ultraviolet absorption photometer (wavelength: 230 nm).

Column: A stainless steel column 4.6 mm in inside diameter and 25 cm in length, packed with octylsilylanized silica gel for liquid chromatography ($10\ \mu\text{m}$ in particle diameter).

Column temperature: A constant temperature of about 35°C .

Mobile phase: Dissolve 1.36 g of potassium dihydrogen phosphate in 900 mL of water, adjust to pH 2.5 with phosphoric acid, and add water to make 1000 mL. To 900 mL of this solution add 600 mL of acetonitrile.

Flow rate: Adjust so that the retention time of losartan is about 5 minutes.

System suitability—

System performance: To 12 mL of the losartan potassium standard stock solution and 4 mL of the hydrochlorothiazide standard stock solution obtained in (2), add 42 mL of a mixture of acetonitrile and sodium dihydrogen phosphate TS (pH 2.5) (3:2), and add sodium dihydrogen phosphate TS (pH 2.5) to make 100 mL. When the procedure is run with $20\ \mu\text{L}$ of this solution under the above operating conditions, hydrochlorothiazide and losartan are eluted in this order with the resolution between these peaks being not less than 10.

System repeatability: When the test is repeated 6 times with $20\ \mu\text{L}$ of the standard solution under the above operating conditions, the relative standard deviation of the peak area of losartan is not more than 1.0%.

(2) Hydrochlorothiazide—Perform the test according to the following method: it meets the requirement of the Content uniformity test.

To 1 tablet of Losartan Potassium and Hydrochlorothiazide Tablets add $V/2$ mL of a mixture of acetonitrile and sodium dihydrogen phosphate TS (pH 2.5) (3:2), and stir for

60 minutes to disintegrate the tablet, add sodium dihydrogen phosphate TS (pH 2.5) to make exactly V mL so that each mL contains about 0.125 mg of hydrochlorothiazide ($C_7H_8ClN_3O_4S_2$). Pipet 10 mL of this solution, add 45 mL of a mixture of acetonitrile and sodium dihydrogen phosphate TS (pH 2.5) (3:2), add sodium dihydrogen phosphate TS (pH 2.5) to make exactly 100 mL, and filter through a membrane filter with a pore size not exceeding $0.45\ \mu\text{m}$. Discard the first 2 mL of the filtrate, and use the subsequent filtrate as the sample solution. Separately, weigh accurately about 35 mg of Hydrochlorothiazide RS (separately determine the loss on drying <2.41> under the same conditions as Hydrochlorothiazide), and dissolve in 50 mL of a mixture of acetonitrile and sodium dihydrogen phosphate TS (pH 2.5) (3:2), add sodium dihydrogen phosphate TS (pH 2.5) to make exactly 100 mL, and use this solution as the hydrochlorothiazide standard stock solution. Pipet 4 mL of the hydrochlorothiazide standard stock solution, add 48 mL of a mixture of acetonitrile and sodium dihydrogen phosphate TS (pH 2.5) (3:2), add sodium dihydrogen phosphate TS (pH 2.5) to make exactly 100 mL, and use this solution as the standard solution. Perform the test with exactly $20\ \mu\text{L}$ each of the sample solution and standard solution as directed under Liquid Chromatography <2.01> according to the following conditions, and determine the peak areas, A_T and A_S , of hydrochlorothiazide in each solution.

$$\text{Amount (mg) of hydrochlorothiazide (C}_{7}\text{H}_{8}\text{ClN}_{3}\text{O}_{4}\text{S}_{2}) \\ = M_S \times A_T/A_S \times V/250$$

M_S : Amount (mg) of Hydrochlorothiazide RS taken, calculated on the dried basis

Operating conditions—

Proceed as directed in the operating conditions in (1).

System suitability—

System performance: To 12 mL of the losartan potassium standard stock solution obtained in (1) and 4 mL of the hydrochlorothiazide standard stock solution, add 42 mL of a mixture of acetonitrile and sodium dihydrogen phosphate TS (pH 2.5) (3:2), and add sodium dihydrogen phosphate TS (pH 2.5) to make 100 mL. When the procedure is run with $20\ \mu\text{L}$ of this solution under the above operating conditions, hydrochlorothiazide and losartan are eluted in this order with the resolution between these peaks being not less than 10.

System repeatability: When the test is repeated 6 times with $20\ \mu\text{L}$ of the standard solution under the above operating conditions, the relative standard deviation of the peak area of hydrochlorothiazide is not more than 1.0%.

Dissolution <6.10> (1) Losartan potassium—When the test is performed at 100 revolutions per minute according to the Basket method, using 900 mL of water as the dissolution medium, the dissolution rate in 30 minutes of Losartan Potassium and Hydrochlorothiazide Tablets is not less than 85%.

Start the test with 1 tablet of Losartan Potassium and Hydrochlorothiazide Tablets, withdraw not less than 10 mL of the medium at the specified minute after starting the test, and filter through a membrane filter with a pore size not exceeding $0.45\ \mu\text{m}$. Discard not less than 2 mL of the first filtrate, pipet V' mL of the subsequent filtrate, add water to make exactly V' mL so that each mL contains about $56\ \mu\text{g}$ of losartan potassium ($C_{22}H_{22}ClKN_6O$), and use this solution as the sample solution. Separately, weigh accurately about 46 mg of Losartan Potassium RS (separately determine the water <2.48> in the same manner as Losartan Potassium), and dissolve in water to make exactly 100 mL, and use this

solution as the losartan potassium standard stock solution. Pipet 12 mL of the losartan potassium standard stock solution, add water to make exactly 100 mL, and use this solution as the standard solution. Perform the test with exactly 20 μ L each of the sample solution and standard solution as directed under Liquid Chromatography <2.01> according to the following conditions, and determine the peak areas, A_T and A_S , of losartan in each solution.

Dissolution rate (%) with respect to the labeled amount of losartan potassium ($C_{22}H_{22}ClKN_6O$)

$$= M_S \times A_T/A_S \times V'/V \times 1/C \times 108$$

M_S : Amount (mg) of Losartan Potassium RS taken, calculated on the anhydrous basis

C: Labeled amount (mg) of losartan potassium ($C_{22}H_{22}ClKN_6O$) in 1 tablet

Operating conditions—

Proceed as directed in the operating conditions in the Uniformity of dosage units (1).

System suitability—

System performance: To 12 mL of the losartan potassium standard stock solution and 8 mL of the hydrochlorothiazide standard stock solution obtained in (2), add water to make 100 mL. When the procedure is run with 20 μ L of this solution under the above operating conditions, hydrochlorothiazide and losartan are eluted in this order with the resolution between these peaks being not less than 10.

System repeatability: When the test is repeated 6 times with 20 μ L of the standard solution under the above operating conditions, the relative standard deviation of the peak area of losartan is not more than 1.0%.

(2) Hydrochlorothiazide—When the test is performed at 100 revolutions per minute according to the Basket method, using 900 mL of water as the dissolution medium, the dissolution rate in 45 minutes of Losartan Potassium and Hydrochlorothiazide Tablets is not less than 80%.

Start the test with 1 tablet of Losartan Potassium and Hydrochlorothiazide Tablets, withdraw not less than 10 mL of the medium at the specified minute after starting the test, and filter through a membrane filter with a pore size not exceeding 0.45 μ m. Discard not less than 2 mL of the first filtrate, pipet V mL of the subsequent filtrate, add water to make exactly V' mL so that each mL contains about 13.9 μ g of hydrochlorothiazide ($C_7H_8ClN_3O_4S_2$), and use this solution as the sample solution. Separately, weigh accurately about 35 mg of Hydrochlorothiazide RS (separately determine the loss on drying <2.41> under the same conditions as Hydrochlorothiazide), dissolve in 20 mL of methanol, and add water to make exactly 200 mL, and use this solution as the hydrochlorothiazide standard stock solution. Pipet 8 mL of hydrochlorothiazide standard stock solution, add water to make exactly 100 mL, and use this solution as the standard solution. Perform the test with exactly 20 μ L each of the sample solution and standard solution as directed under Liquid Chromatography <2.01> according to the following conditions, and determine the peak areas, A_T and A_S , of hydrochlorothiazide in each solution.

Dissolution rate (%) with respect to the labeled amount of hydrochlorothiazide ($C_7H_8ClN_3O_4S_2$)

$$= M_S \times A_T/A_S \times V'/V \times 1/C \times 36$$

M_S : Amount (mg) of Hydrochlorothiazide RS taken, calculated on the dried basis

C: Labeled amount (mg) of hydrochlorothiazide ($C_7H_8ClN_3O_4S_2$) in 1 tablet

Operating conditions—

Proceed as directed in the operating conditions in the Uniformity of dosage units (1).

System suitability—

System performance: To 12 mL of the losartan potassium standard stock solution obtained in (1) and 8 mL of the hydrochlorothiazide standard stock solution, add water to make 100 mL. When the procedure is run with 20 μ L of this solution under the above operating conditions, hydrochlorothiazide and losartan are eluted in this order with the resolution between these peaks being not less than 10.

System repeatability: When the test is repeated 6 times with 20 μ L of the standard solution under the above operating conditions, the relative standard deviation of the peak area of hydrochlorothiazide is not more than 1.0%.

Assay (1) Losartan potassium—To 10 Losartan Potassium and Hydrochlorothiazide Tablets add 21 V /25 mL of a mixture of acetonitrile and sodium dihydrogen phosphate TS (pH 2.5) (3:2), stir for 60 minutes to disintegrate the tablets, add sodium dihydrogen phosphate TS (pH 2.5) to make exactly V mL so that each mL contains about 2 mg of losartan potassium ($C_{22}H_{22}ClKN_6O$), and sonicate for 2 minutes. Pipet 10 mL of this solution, add 10 mL of acetonitrile, and add sodium dihydrogen phosphate TS (pH 2.5) to make exactly 50 mL, and filter through a membrane filter with a pore size not exceeding 0.45 μ m. Discard the first 2 mL of the filtrate, and use the subsequent filtrate as the sample solution. Separately, weigh accurately about 40 mg of Losartan Potassium RS (separately determine the water <2.48> in the same manner as Losartan Potassium), and dissolve in 30 mL of a mixture of acetonitrile and sodium dihydrogen phosphate TS (pH 2.5) (3:2), add sodium dihydrogen phosphate TS (pH 2.5) to make exactly 50 mL, and use this solution as the losartan potassium standard stock solution. Pipet 10 mL of the losartan potassium standard stock solution, add 4 mL of a mixture of acetonitrile and sodium dihydrogen phosphate TS (pH 2.5) (3:2), add sodium dihydrogen phosphate TS (pH 2.5) to make exactly 20 mL, and use this solution as the standard solution. Perform the test with exactly 20 μ L each of the sample solution and standard solution as directed under Liquid Chromatography <2.01> according to the following conditions, and determine the peak areas, A_T and A_S , of losartan in each solution.

Amount (mg) of losartan potassium ($C_{22}H_{22}ClKN_6O$) in 1 tablet

$$= M_S \times A_T/A_S \times V/200$$

M_S : Amount (mg) of Losartan Potassium RS taken, calculated on the anhydrous basis

Operating conditions—

Detector: An ultraviolet absorption photometer (wavelength: 280 nm).

Column: A stainless steel column 3.9 mm in inside diameter and 15 cm in length, packed with octylsilanized silica gel for liquid chromatography (5 μ m in particle diameter).

Column temperature: A constant temperature of about 35°C.

Mobile phase A: Dissolve 1.25 g of potassium dihydrogen phosphate and 1.5 g of anhydrous disodium hydrogen phosphate in water to make 1000 mL. To 930 mL of this solution add 70 mL of acetonitrile.

Mobile phase B: Acetonitrile.

Flowing of mobile phase: Control the gradient by mixing the mobile phases A and B as directed in the following table.

Time after injection of sample (min)	Mobile phase A (vol%)	Mobile phase B (vol%)
0 - 12	100 → 92	0 → 8
12 - 28	92 → 38	8 → 62

Flow rate: Adjust so that the retention time of losartan is about 20 minutes.

System suitability—

System performance: To 25 mL of the losartan potassium standard stock solution and 10 mL of the hydrochlorothiazide standard stock solution obtained in (2), add sodium dihydrogen phosphate TS (pH 2.5) to make 50 mL. When the procedure is run with 20 μ L of this solution under the above operating conditions, hydrochlorothiazide and losartan are eluted in this order, and the number of theoretical plates of the peak of hydrochlorothiazide and the symmetry factor of the peak of losartan are not less than 4000 and not more than 2.5, respectively.

System repeatability: When the test is repeated 6 times with 20 μ L of the standard solution under the above operating conditions, the relative standard deviation of the peak area of losartan is not more than 1.0%.

(2) **Hydrochlorothiazide**—To 10 Losartan Potassium and Hydrochlorothiazide Tablets add 21 V/25 mL of a mixture of acetonitrile and sodium dihydrogen phosphate TS (pH 2.5) (3:2), stir for 60 minutes to disintegrate the tablets, add sodium dihydrogen phosphate TS (pH 2.5) to make exactly V mL so that each mL contains about 0.5 mg of hydrochlorothiazide (C₇H₈ClN₃O₄S₂), and sonicate for 2 minutes. Pipet 10 mL of this solution, add 10 mL of acetonitrile, and add sodium dihydrogen phosphate TS (pH 2.5) to make exactly 50 mL, and filter through a membrane filter with a pore size not exceeding 0.45 μ m. Discard the first 2 mL of the filtrate, and use the subsequent filtrate as the sample solution. Separately, weigh accurately about 25 mg of Hydrochlorothiazide RS (separately determine the loss on drying <2.41> under the same conditions as Hydrochlorothiazide), and dissolve in a mixture of acetonitrile and sodium dihydrogen phosphate TS (pH 2.5) (3:2), to make exactly 50 mL, and use this solution as the hydrochlorothiazide standard stock solution. Pipet 20 mL of the hydrochlorothiazide standard stock solution, add 30 mL of a mixture of acetonitrile and sodium dihydrogen phosphate TS (pH 2.5) (3:2), add sodium dihydrogen phosphate TS (pH 2.5) to make exactly 100 mL, and use this solution as the standard solution. Perform the test with exactly 20 μ L each of the sample solution and standard solution as directed under Liquid Chromatography <2.01> according to the following conditions, and determine the peak areas, A_T and A_S, of hydrochlorothiazide in each solution.

$$\begin{aligned} &\text{Amount (mg) of hydrochlorothiazide (C}_7\text{H}_8\text{ClN}_3\text{O}_4\text{S}_2\text{)} \\ &\text{in 1 tablet} \\ &= M_S \times A_T/A_S \times V/500 \end{aligned}$$

M_S: Amount (mg) of Hydrochlorothiazide RS taken, calculated on the dried basis

Operating conditions—

Proceed as directed in the operating conditions in (1).

System suitability—

System performance: To 25 mL of the losartan potassium standard stock solution obtained in (1) and 10 mL of the hydrochlorothiazide standard stock solution, add sodium dihydrogen phosphate TS (pH 2.5) to make 50 mL. When the procedure is run with 20 μ L of this solution under the above

operating conditions, hydrochlorothiazide and losartan are eluted in this order, and the number of theoretical plates of the peak of hydrochlorothiazide and the symmetry factor of the peak of losartan are not less than 4000 and not more than 2.5, respectively.

System repeatability: When the test is repeated 6 times with 20 μ L of the standard solution under the above operating conditions, the relative standard deviation of the peak area of hydrochlorothiazide is not more than 1.0%.

Containers and storage Containers—Tight containers.

Loxoprofen Sodium Hydrate

ロキソプロフェンナトリウム水和物

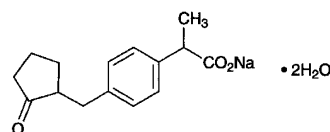

C₁₅H₁₇NaO₃·2H₂O: 304.31

Monosodium 2-[4-[(2-oxocyclopentyl)methyl]phenyl]propanoate dihydrate [80382-23-6]

Loxoprofen Sodium Hydrate contains not less than 98.5% of loxoprofen sodium (C₁₅H₁₇NaO₃: 268.28), calculated on the anhydrous basis.

Description Loxoprofen Sodium Hydrate occurs as white to yellowish white, crystals or crystalline powder.

It is very soluble in water and in methanol, freely soluble in ethanol (95), and practically insoluble in diethyl ether.

A solution of Loxoprofen Sodium Hydrate (1 in 20) does not show optical rotation.

The pH of a solution of 1.0 g of Loxoprofen Sodium Hydrate in 20 mL of freshly boiled and cooled water is between 6.5 and 8.5.

Identification (1) Determine the absorption spectrum of a solution of Loxoprofen Sodium Hydrate (1 in 55,000) as directed under Ultraviolet-visible Spectrophotometry <2.24>, and compare the spectrum with the Reference Spectrum: both spectra exhibit similar intensities of absorption at the same wavelengths.

(2) Determine the infrared absorption spectrum of Loxoprofen Sodium Hydrate as directed in the potassium bromide disk method under the Infrared Spectrophotometry <2.25>, and compare the spectrum with the Reference Spectrum: both spectra exhibit similar intensities of absorption at the same wave numbers.

(3) A solution of Loxoprofen Sodium Hydrate (1 in 10) responds to Qualitative Tests <1.09> for sodium salt.

Purity (1) Clarity and color of solution—Dissolve 1.0 g of Loxoprofen Sodium Hydrate in 10 mL of water: the solution is clear and colorless or pale yellow. The color is not darker than that of diluted Matching Fluid A (1 in 2).

(2) Heavy metals <1.07>—Proceed with 2.0 g of Loxoprofen Sodium Hydrate according to Method 2, and perform the test. Prepare the control solution with 2.0 mL of Standard Lead Solution (not more than 10 ppm).

(3) Related substances—Dissolve 1.0 g of Loxoprofen Sodium Hydrate in 10 mL of methanol, and use this solution as the sample solution. Pipet 1 mL of the sample solution, add methanol to make exactly 200 mL, and use this solution

as the standard solution. Perform the test with these solutions as directed under Thin-layer Chromatography <2.03>. Spot 10 μL each of the sample solution and standard solution on a plate of silica gel with fluorescent indicator for thin-layer chromatography. Develop the plate with a mixture of 1,2-dichloroethane and acetic acid (100) (9:1) to a distance of about 15 cm, and air-dry the plate. Examine under ultraviolet light (main wavelength: 254 nm): the spots other than the principal spot obtained from the sample solution are not more intense than the spot from the standard solution.

Water <2.48> 11.0 – 13.0% (0.2 g, volumetric titration, direct titration).

Assay Weigh accurately about 60 mg of Loxoprofen Sodium Hydrate, and dissolve in diluted methanol (3 in 5) to make exactly 100 mL. Pipet 5 mL of this solution, add exactly 10 mL of the internal standard solution, add diluted methanol (3 in 5) to make 100 mL, and use this solution as the sample solution. Separately, weigh accurately about 50 mg of Loxoprofen RS, previously dried in a desiccator (in vacuum, 60°C) for 3 hours, and dissolve in diluted methanol (3 in 5) to make exactly 100 mL. Pipet 5 mL of this solution, proceed in the same manner as directed for the preparation of the sample solution, and use so obtained solution as the standard solution. Perform the test with 10 μL each of the sample solution and standard solution as directed under Liquid Chromatography <2.01> according to the following conditions, and calculate the ratios, Q_T and Q_S , of the peak area of loxoprofen to that of the internal standard.

$$\begin{aligned} &\text{Amount (mg) of loxoprofen sodium (C}_{15}\text{H}_{17}\text{NaO}_3) \\ &= M_S \times Q_T/Q_S \times 1.089 \end{aligned}$$

M_S : Amount (mg) of Loxoprofen RS taken

Internal standard solution—A solution of ethyl benzoate in diluted methanol (3 in 5) (7 in 50,000).

Operating conditions—

Detector: An ultraviolet absorption photometer (wavelength: 222 nm).

Column: A stainless steel column 4.6 mm in inside diameter and 15 cm in length, packed with octadecylsilanized silica gel for liquid chromatography (5 μm in particle diameter).

Column temperature: A constant temperature of about 40°C.

Mobile phase: A mixture of methanol, water, acetic acid (100) and triethylamine (600:400:1:1).

Flow rate: Adjust so that the retention time of loxoprofen is about 7 minutes.

System suitability—

System performance: When the procedure is run with 10 μL of the standard solution under the above operating conditions, loxoprofen and the internal standard are eluted in this order with the resolution between these peaks being not less than 10.

System repeatability: When the test is repeated 5 times with 10 μL of the standard solution under the above operating conditions, the relative standard deviation of the ratios of the peak area of loxoprofen to that of the internal standard is not more than 1.0%.

Containers and storage Containers—Tight containers.

Loxoprofen Sodium Tablets

ロキソプロフェンナトリウム錠

Loxoprofen Sodium Tablets contain not less than 95.0% and not more than 105.0% of the labeled amount of loxoprofen sodium (C₁₅H₁₇NaO₃; 268.28).

Method of preparation Prepare as directed under Tablets, with Loxoprofen Sodium Hydrate.

Identification To a quantity of powdered Loxoprofen Sodium Tablets, equivalent to 60 mg of loxoprofen sodium (C₁₅H₁₇NaO₃), add 20 mL of methanol, shake vigorously for 10 minutes, and centrifuge. To 1 mL of the supernatant liquid add methanol to make 20 mL. To 2 mL of this solution add methanol to make 20 mL, and determine the absorption spectrum of this solution as directed under Ultraviolet-visible Spectrophotometry <2.24>: it exhibits a maximum between 221 nm and 225 nm.

Uniformity of dosage units <6.02> Perform the Mass variation test, or the Content uniformity test according to the following method: it meets the requirement.

To 1 tablet of Loxoprofen Sodium Tablets add exactly V mL of the internal standard solution so that each mL contains about 3 mg of loxoprofen sodium (C₁₅H₁₇NaO₃). After sonicating for 10 minutes with occasional shaking, centrifuge the solution. To 2 mL of the supernatant liquid add diluted methanol (3 in 5) to make 100 mL, and use this solution as the sample solution. Then, proceed as directed in the Assay.

$$\begin{aligned} &\text{Amount (mg) of loxoprofen sodium (C}_{15}\text{H}_{17}\text{NaO}_3) \\ &= M_S \times Q_T/Q_S \times V/10 \times 1.089 \end{aligned}$$

M_S : Amount (mg) of Loxoprofen RS taken

Internal standard solution—A solution of ethyl benzoate in diluted methanol (3 in 5) (3 in 2000).

Dissolution <6.10> When the test is performed at 50 revolutions per minute according to the Paddle method, using 900 mL of water as the dissolution medium, the dissolution rate in 30 minutes of Loxoprofen Sodium Tablets is not less than 85%.

Start the test with 1 tablet of Loxoprofen Sodium Tablets, withdraw not less than 20 mL of the medium at the specified minute after starting the test, and filter through a membrane filter with a pore size not exceeding 0.8 μm . Discard not less than 10 mL of the first filtrate, pipet V mL of the subsequent filtrate, and add 2nd fluid for dissolution test to make exactly V' mL so that each mL contains about 13 μg of loxoprofen sodium (C₁₅H₁₇NaO₃). Use this solution as the sample solution. Separately, weigh accurately about 31 mg of Loxoprofen RS, previously dried in vacuum at 60°C for 3 hours, dissolve in 5 mL of ethanol (99.5), and add water to make exactly 250 mL. Pipet 5 mL of this solution, add 2nd fluid for dissolution test to make exactly 50 mL, and use this solution as the standard solution. Determine the absorbances, A_T and A_S , of the sample solution and standard solution at 223 nm as directed under Ultraviolet-visible Spectrophotometry <2.24>, using water as the control.

$$\begin{aligned} &\text{Dissolution rate (\%)} \text{ with respect to the labeled amount} \\ &\text{of loxoprofen sodium (C}_{15}\text{H}_{17}\text{NaO}_3) \\ &= M_S \times A_T/A_S \times V'/V \times 1/C \times 36 \times 1.089 \end{aligned}$$

M_S : Amount (mg) of Loxoprofen RS taken

C : Labeled amount (mg) of loxoprofen sodium

(C₁₅H₁₇NaO₃) in 1 tablet

Assay Weigh accurately the mass of not less than 20 Loxoprofen Sodium Tablets, and powder. Weigh accurately a portion of the powder, equivalent to about 60 mg of loxoprofen sodium (C₁₅H₁₇NaO₃), add exactly 20 mL of the internal standard solution, and shake vigorously for 15 minutes. Centrifuge this solution, and to 2 mL of the supernatant liquid add diluted methanol (3 in 5) to make 100 mL. Use this solution as the sample solution. Separately, weigh accurately about 30 mg of Loxoprofen RS, previously dried in vacuum at 60°C for 3 hours, and dissolve in exactly 10 mL of the internal standard solution. To 2 mL of this solution add diluted methanol (3 in 5) to make 100 mL, and use this solution as the standard solution. Perform the test with 10 μL each of the sample solution and standard solution as directed under Liquid Chromatography <2.01> according to the following conditions, and calculate the ratios, Q_T and Q_S, of the peak area of loxoprofen to that of the internal standard.

$$\begin{aligned} & \text{Amount (mg) of loxoprofen sodium (C}_{15}\text{H}_{17}\text{NaO}_3\text{)} \\ & = M_S \times Q_T / Q_S \times 2 \times 1.089 \end{aligned}$$

M_S: Amount (mg) of Loxoprofen RS taken

Internal standard solution—A solution of ethyl benzoate in diluted methanol (3 in 5) (3 in 2000).

Operating conditions—

Detector: An ultraviolet absorption photometer (wavelength: 222 nm).

Column: A stainless steel column 6 mm in inside diameter and 15 cm in length, packed with octadecylsilanized silica gel for liquid chromatography (5 μm in particle diameter).

Column temperature: A constant temperature of about 40°C.

Mobile phase: A mixture of methanol, water, acetic acid (100) and triethylamine (600:400:1:1).

Flow rate: Adjust so that the retention time of loxoprofen is about 7 minutes.

System suitability—

System performance: When the procedure is run with 10 μL of the standard solution under the above operating conditions, loxoprofen and the internal standard are eluted in this order with the resolution between these peaks being not less than 10.

System repeatability: When the test is repeated 6 times with 10 μL of the standard solution under the above operating conditions, the relative standard deviation of the ratio of the peak area of loxoprofen to that of the internal standard is not more than 1.0%.

Containers and storage Containers—Tight containers.

L-Lysine Acetate

L-リシン酢酸塩

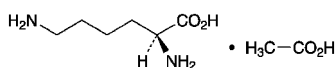

C₆H₁₄N₂O₂·C₂H₄O₂; 206.24

(2S)-2,6-Diaminohexanoic acid monoacetate
[57282-49-2]

L-Lysine Acetate, when dried, contains not less than 98.5% and not more than 101.0% of L-lysine acetate (C₆H₁₄N₂O₂·C₂H₄O₂).

Description L-Lysine Acetate occurs as white, crystals or crystalline powder. It has a characteristic odor and a slightly acid taste.

It is very soluble in water, freely soluble in formic acid, and practically insoluble in ethanol (99.5).

It is deliquescent.

Identification (1) Determine the infrared absorption spectrum of L-Lysine Acetate as directed in the potassium bromide disk method under Infrared Spectrophotometry <2.25>, and compare the spectrum with the Reference Spectrum: both spectra exhibit similar intensities of absorption at the same wave numbers.

(2) A solution of L-Lysine Acetate (1 in 20) responds to Qualitative Tests <1.09> (2) for acetate.

Optical rotation <2.49> [α]_D²⁰: +8.5 – +10.0° (after drying, 2.5 g, water, 25 mL, 100 mm).

pH <2.54> Dissolve 1.0 g of L-Lysine Acetate in 10 mL of water: the pH of the solution is between 6.5 and 7.5.

Purity (1) Clarity and color of solution—Dissolve 1.0 g of L-Lysine Acetate in 10 mL of water: the solution is colorless and clear.

(2) Chloride <1.03>—Perform the test with 0.5 g of L-Lysine Acetate. Prepare the control solution with 0.30 mL of 0.01 mol/L hydrochloric acid VS (not more than 0.021%).

(3) Sulfate <1.14>—Perform the test with 0.6 g of L-Lysine Acetate. Prepare the control solution with 0.35 mL of 0.005 mol/L sulfuric acid VS (not more than 0.028%).

(4) Ammonium <1.02>—Perform the test with 0.25 g of L-Lysine Acetate. Prepare the control solution with 5.0 mL of Standard Ammonium Solution (not more than 0.02%).

(5) Heavy metals <1.07>—Proceed with 1.0 g of L-Lysine Acetate according to Method 4, and perform the test. Prepare the control solution with 1.0 mL of Standard Lead Solution (not more than 10 ppm).

(6) Iron <1.10>—Prepare the test solution with 1.0 g of L-Lysine Acetate according to Method 1, and perform the test according to Method A. Prepare the control solution with 1.0 mL of Standard Iron Solution (not more than 10 ppm).

(7) Related substances—Weigh accurately about 0.5 g of L-Lysine Acetate, dissolve in 0.5 mL of hydrochloric acid and water to make exactly 100 mL. Pipet 10 mL of this solution, add 0.02 mol/L hydrochloric acid to make exactly 50 mL, and use this solution as the sample solution. Separately, weigh accurately 2.5 mmol amounts of L-aspartic acid, L-threonine, L-serine, L-glutamic acid, glycine, L-alanine, L-cystine, L-valine, L-methionine, L-isoleucine, L-leucine, L-tyrosine, L-phenylalanine, L-lysine hydrochloride, ammonium chloride, L-histidine and L-arginine, dissolve in 0.1 mol/L hydrochloric acid TS to make exactly 1000 mL, and use this solution as the standard stock solution. Pipet 5 mL of this solution, add 0.02 mol/L hydrochloric acid to make exactly 100 mL. Pipet 4 mL of this solution, add 0.02 mol/L hydrochloric acid to make exactly 50 mL, and use this solution as the standard solution. Perform the test with exactly 20 μL each of the sample solution and standard solution as directed under Liquid Chromatography <2.01> according to the following conditions. Based on the peak heights of the amino acids obtained from the sample solution and standard solution, determine the mass of the amino acids other than lysine contained in 1 mL of the sample solution, and calculate the mass percent: the amount of each amino acids other than lysine is not more than 0.1%.

Operating conditions—

Detector: A visible spectrophotometer (wavelength: 570 nm).

Column: A stainless steel column 4.6 mm in inside diameter and 8 cm in length, packed with strongly acidic ion-exchange resin for liquid chromatography (Na type) composed with a sulfonated polystyrene copolymer (3 μm in particle diameter).

Column temperature: A constant temperature of about 57°C.

Chemical reaction bath temperature: A constant temperature of about 130°C.

Color developing time: About 1 minute.

Mobile phase: Prepare mobile phases A, B, C, D and E according to the following table, and to each phase add 0.1 mL of capric acid.

	Mobile phase A	Mobile phase B	Mobile phase C	Mobile phase D	Mobile phase E
Citric acid monohydrate	19.80 g	22.00 g	12.80 g	6.10 g	—
Trisodium citrate dihydrate	6.19 g	7.74 g	13.31 g	26.67 g	—
Sodium chloride	5.66 g	7.07 g	3.74 g	54.35 g	—
Sodium hydroxide	—	—	—	—	8.00 g
Ethanol (99.5)	130 mL	20 mL	4 mL	—	100 mL
Thiodiglycol	5 mL	5 mL	5 mL	—	—
Benzyl alcohol	—	—	—	5 mL	—
Lauromacrogol solution (1 in 4)	4 mL	4 mL	4 mL	4 mL	4 mL
Water	Appropriate amount	Appropriate amount	Appropriate amount	Appropriate amount	Appropriate amount
Total volume	1000 mL	1000 mL	1000 mL	1000 mL	1000 mL

Changing mobile phases: Proceed with 20 μL of the standard solution under the above operating conditions: aspartic acid, threonine, serine, glutamic acid, glycine, alanine, cysteine, valine, methionine, isoleucine, leucine, tyrosine, phenylalanine, lysine, ammonia, histidine and arginine are eluted in this order. Switchover the mobile phases A, B, C, D and E in sequence so that the resolution between the peaks of isoleucine and leucine is not less than 1.2.

Reaction reagents: Dissolve 204 g of lithium acetate dihydrate in water, and add 123 mL of acetic acid (100), 401 mL of 1-methoxy-2-propanol, and water to make 1000 mL, gas with nitrogen for 10 minutes, and use this solution as the solution (I). Separately, to 979 mL of 1-methoxy-2-propanol add 39 g of ninhydrin, gas with nitrogen for 5 minutes, add 81 mg of sodium borohydride, gas the solution with nitrogen for 30 minutes, and use this solution as solution (II). To 1 volume of the solution (I) add 1 volume of the solution (II). Prepare before use.

Mobile phase flow rate: 0.20 mL per minute.

Reaction reagent flow rate: 0.24 mL per minute.

System suitability—

System performance: When the procedure is run with 20 μL of the standard solution under the above operating conditions, the resolution between the peaks of glycine and alanine is not less than 1.2.

System repeatability: When the test is repeated 6 times with 20 μL of the standard solution under the above operating conditions, the relative standard deviation of the peak height of each amino acid in the standard solution is not more than 5.0%, and the relative standard deviation of the retention time is not more than 1.0%.

Loss on drying <2.41> Not more than 0.3% (1 g, 80°C, 3 hours).

Residue on ignition <2.44> Not more than 0.1% (1 g).

Assay Weigh accurately about 0.1 g of L-Lysine Acetate, previously dried, dissolve in 3 mL of formic acid, add 50 mL of acetic acid (100), and titrate <2.50> with 0.1 mol/L perchloric acid VS (potentiometric titration). Perform a blank determination in the same manner, and make any necessary correction.

Each mL of 0.1 mol/L perchloric acid VS
= 10.31 mg of C₆H₁₄N₂O₂·C₂H₄O₂

Containers and storage Containers—Tight containers.

L-Lysine Hydrochloride

L-リシン塩酸塩

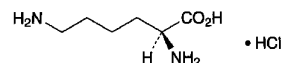

C₆H₁₄N₂O₂·HCl: 182.65

(2S)-2,6-Diaminohexanoic acid monohydrochloride
[657-27-2]

L-Lysine Hydrochloride, when dried, contains not less than 98.5% of L-lysine hydrochloride (C₆H₁₄N₂O₂·HCl).

Description L-Lysine Hydrochloride occurs as a white powder. It has a slight, characteristic taste.

It is freely soluble in water and in formic acid, and practically insoluble in ethanol (95).

It shows crystal polymorphism.

Identification (1) Determine the infrared absorption spectrum of L-Lysine Hydrochloride, previously dried, as directed in the potassium bromide disk method under Infrared Spectrophotometry <2.25>, and compare the spectrum with the Reference Spectrum: both spectra exhibit similar intensities of absorption at the same wave numbers. If any difference appears between the spectra, dissolve L-Lysine Hydrochloride in water, evaporate the water to dryness at 60°C, and repeat the test with the residue.

(2) A solution of L-Lysine Hydrochloride (1 in 10) responds to Qualitative Tests <1.09> for chloride.

Optical rotation <2.49> [α]_D²⁰: +19.0 – +21.5° (after drying, 2 g, 6 mol/L hydrochloric acid TS, 25 mL, 100 mm).

pH <2.54> Dissolve 1.0 g of L-Lysine Hydrochloride in 10 mL of water: the pH of this solution is between 5.0 and 6.0.

Purity (1) Clarity and color of solution—Dissolve 1.0 g of L-Lysine Hydrochloride in 10 mL of water: the solution is clear and colorless.

(2) Sulfate <1.14>—Perform the test with 0.6 g of L-Lysine Hydrochloride. Prepare the control solution with 0.35 mL of 0.005 mol/L sulfuric acid VS (not more than 0.028%).

(3) Ammonium <1.02>—Perform the test with 0.25 g of L-Lysine Hydrochloride. Prepare the control solution with 5.0 mL of Standard Ammonium Solution (not more than 0.02%).

(4) Heavy metals <1.07>—Proceed with 2.0 g of L-Lysine Hydrochloride according to Method 1, and perform the test. Prepare the control solution with 2.0 mL of Standard Lead Solution (not more than 10 ppm).

(5) Arsenic <1.11>—Prepare the test solution with 1.0 g of L-Lysine Hydrochloride according to Method 1, and per-

form the test (not more than 2 ppm).

(6) Related substances—Dissolve 0.10 g of L-Lysine Hydrochloride in 25 mL of water, and use this solution as the sample solution. Pipet 1 mL of the sample solution, add water to make exactly 50 mL, pipet 5 mL of this solution, add water to make exactly 20 mL, and use this solution as the standard solution. Perform the test with these solutions as directed under Thin-layer Chromatography <2.03>. Spot 5 μ L each of the sample solution and standard solution on a plate of silica gel for thin-layer chromatography. Develop the plate with a mixture of 1-propanol and ammonia water (28) (67:33) to a distance of about 10 cm, and dry the plate at 100°C for 30 minutes. Spray evenly the plate with a solution of ninhydrin in acetone (1 in 50) and heat the plate at 80°C for 5 minutes: the spots other than the principal spot obtained from the sample solution are not more intense than the spot from the standard solution.

Loss on drying <2.41> Not more than 1.0% (1 g, 105°C, 3 hours).

Residue on ignition <2.44> Not more than 0.1% (1 g).

Assay Weigh accurately about 0.1 g of L-Lysine Hydrochloride, previously dried, dissolve in 2 mL of formic acid, add exactly 15 mL of 0.1 mol/L perchloric acid VS, and heat on a water bath for 30 minutes. After cooling, add 45 mL of acetic acid (100), and titrate <2.50> the excess perchloric acid with 0.1 mol/L sodium acetate VS (potentiometric titration). Perform a blank determination in the same manner, and make any necessary correction.

Each mL of 0.1 mol/L perchloric acid VS
= 9.132 mg of C₆H₁₄N₂O₂·HCl

Containers and storage Containers—Tight containers.

Lysozyme Hydrochloride

リゾチーム塩酸塩

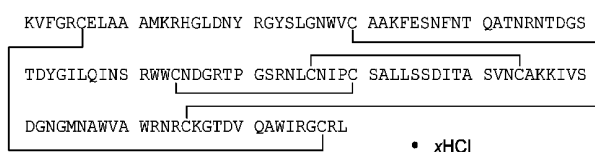

C₆₁₆H₉₆₃N₁₉₃O₁₈₂S₁₀·xHCl
[12650-88-3, egg white lysozyme]

Lysozyme Hydrochloride is the hydrochloride of lysozyme obtained from albumen of hen's egg, and is a protein consisting of 129 amino acid residues.

It contains not less than 0.9 mg (potency) of lysozyme per mg, calculated on the dried basis.

Description Lysozyme Hydrochloride occurs as white, crystals, or crystalline or amorphous powder.

It is freely soluble in water, and practically insoluble in ethanol (99.5).

It is hygroscopic.

The pH of a solution of 3 g of Lysozyme Hydrochloride in 200 mL of water is between 3.0 and 5.0.

Identification (1) To 5 mL of a solution of Lysozyme Hydrochloride in acetate buffer solution (pH 5.4) (1 in 500) add 1 mL of ninhydrin TS, and heat for 10 minutes: a blue-purple color develops.

(2) Determine the absorption spectrum of a solution of Lysozyme Hydrochloride in acetate buffer solution (pH 5.4)

(1 in 10,000) as directed under Ultraviolet-visible Spectrophotometry <2.24>, and compare the spectrum with the Reference Spectrum: both spectra exhibit similar intensities of absorption at the same wavelengths.

Purity (1) Clarity of solution—To 5 mL of a solution of Lysozyme Hydrochloride (3 in 200) add, if necessary, dilute hydrochloric acid to adjust the pH to 3: the solution is clear.

(2) Heavy metals <1.07>—Proceed with 1.0 g of Lysozyme Hydrochloride according to Method 2, and perform the test. Prepare the control solution with 2.0 mL of Standard Lead Solution (not more than 20 ppm).

Loss on drying <2.41> Not more than 8.0% (0.1 g, 105°C, 2 hours).

Residue on ignition <2.44> Not more than 2.0% (0.5 g).

Nitrogen Perform the test as directed under Nitrogen Determination <1.08>: the amount of nitrogen (N: 14.01) is between 16.8% and 18.6%, calculated on the dried basis.

Assay Weigh accurately an amount of Lysozyme Hydrochloride, equivalent to about 25 mg (potency), dissolve in phosphate buffer solution (pH 6.2) to make exactly 100 mL. Pipet 2 mL of this solution, add phosphate buffer solution (pH 6.2) to make exactly 50 mL, and use this solution as the sample solution. Separately, weigh accurately an amount of Lysozyme RS (separately determine its loss on drying <2.41> under the same condition as Lysozyme Hydrochloride), equivalent to about 25 mg (potency), and dissolve in phosphate buffer solution (pH 6.2) to make exactly 100 mL. Pipet 1 mL and 2 mL of this solution, add phosphate buffer solution (pH 6.2) to them to make exactly 50 mL, and use these solutions as the standard solution (1) and the solution (2), respectively. Keep the sample solution and the standard solutions in an ice-bath. Pipet 4 mL of substrate solution for lysozyme hydrochloride, previously warmed in a water bath of 35°C for about 5 minutes, add exactly 100 μ L of the sample solution, previously warmed in a water bath of 35°C for about 3 minutes, and allow to stand at 35°C for exactly 10 minutes, then add exactly 0.5 mL of 1 mol/L hydrochloric acid TS, and immediately shake. Determine the absorbance under Ultraviolet-visible Spectrophotometry <2.24>, A_T , of this solution at 640 nm, using water as the blank. Determine the absorbances, A_{S1} and A_{S2} , of the solutions obtained with the standard solution (1) and the standard solution (2) in the same manner as the sample solution.

Amount [mg (potency)] of lysozyme per mg,
calculated on the dried basis

$$= M_S/2M_T \times \{(A_{S1} - A_T)/(A_{S1} - A_{S2}) + 1\}$$

M_S : Amount (mg) of Lysozyme RS taken, calculated on the dried basis.

M_T : Amount (mg) of the sample taken, calculated on the dried basis.

Containers and storage Containers—Tight containers.